

Operations Manual

Model: DP2300BZE
Blaze Automatic
Dough Press



DOUGHPRO[®]



PROLUXE  TM

formerly DOUGHPRO. New Name. Same Quality. Superior Service.

proluxe.com

Congratulations!

Your selection of the Doughpro DP2300 is a sound business decision. Doughpro equipment is a result of the highest quality engineering and time-tested design. Your machine, combined with Doughpro's reputation of innovation in dough press equipment manufacturing, insures the continuing capability of delivering the best-decorated product possible.

This manual describes installation, operation, and maintenance procedures for your new model DP2300.

Your model DP2300 machine will have a long trouble-free life. Read this manual carefully and keep it with your machine; it's your key to proper operation and lasting service.

Installation



DOMESTIC

Use a separate 30 amp AC circuit. Only industrial extension cords with proper wire size should be used; size 16/3 wire for distance up to 25 feet, and size 14/3 for distance up to 50 feet.



INTERNATIONAL

Use a designated 30amp AC circuit. Only industrial extension cords with proper wire size (2.5 sq. mm) shall be used.

Make sure there is a proper electrical wall outlet located within reach of the cord and plug attached to the press. Then place the press in an area which allows for "swing clearance" of the lower platen plus vertical and horizontal clearance of the press itself.

Limited Machine Warranty

Doughpro warrants this dough press machine, when operated under normal

conditions, to be free from manufacturing defects in material and workmanship for a period of one year on parts and labor from the invoice date.

This warranty will be effective only when Doughpro authorizes the original purchaser to return the product to the factory in Perris, California freight prepaid and only when the product, upon examination, has proven to be defective.

This warranty does not apply to any machine that has been subjected to misuse, negligence or accident.

Doughpro shall not be liable for the injury, loss or damage, direct or consequential, arising out of the use or the inability to use the product.

No claim of any kind shall be greater in amount than the sale price of the product or part to which claim is made.

This is the sole warranty given by the company, it is in lieu of any other warranties, expressed or implied, in law or in fact, including the warranties of merchantability and fitness for a particular use, and is accepted such by the purchaser in taking delivery of this product.

Specifications

Electrical:

208V/50-60Hz/4600W/22.11Amps

Includes 72" cord and NEMA approved plug.

Shipping Weight:

200lbs. (91kg.) – DP2300

Safety Summary

WARNING

In case of power cord damage, do not attempt to repair or replace the power cord. Contact the manufacturer or the local distributor.





WARNING

Avoid touching hot surfaces while operating the machine.



CAUTION

During normal operation, the base of the machine must be installed or placed above the wall socket.



CAUTION

When servicing or cleaning the machine, make sure that the power cord is removed from the wall socket.

Operation Timer/Temperature Control

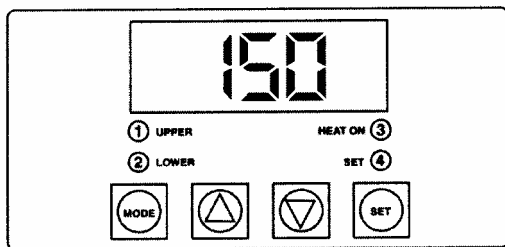

Fig. A

Solid State Controller

This controller has three (3) control features:

1. Temperature – May be set from 100°-425°F (38°-163°C)
2. Time – Time may be set from 1 second to 10 minutes.
3. Counter – Cycle counter counts the number of applications from 1 to 9999 (see additional Notes – Counter).
4. “ⓄLower” (Fig. A) Refers to models using upper and lower heated surfaces.

Controller Operation

1. Viewing the Modes of Operation:

- To view the set points of temperature, timer and counter, press MODE button to view the desired mode of operation.

2. Changing Temperature:

- Press **MODE** button until temperature is displayed.
- Press and hold **SET** button while pressing the **UP** (↑) and **DOWN** (↓) arrow buttons to desired temperature setting.

3. Changing Time:

- Press **MODE** button until time is displayed.
- Press and hold **SET** button while pressing the **UP** (↑) and **DOWN** (↓) arrow buttons to desired timer setting.



The **DISENGAGE** switch may be pressed anytime during a cycle, and the cycle will stop immediately, and the timer will reset.

4. Resetting the Counter

- Press MODE button until the counter is displayed.
- To Reset the Counter (# of Cycles), simultaneously push UP (↑) or DOWN (↓) arrow buttons (approx. 5 seconds).

PRESSING DOUGH:

For best results, your dough should be proofed before pressing, but it will also press directly out of your refrigerator.

Flour is not required to press a crust and should not be dusted on any part of the machine.

D1400C Cabinet & Compressor

1. After connecting the air hose line from the compressor to the press, plug it into the properly rated electrical outlet for your press and air compressor cabinet. Verify the electrical requirements against the nameplate on the

back of the press and air compressor cabinet.

Note: The compressor portion of the machine has a separate on/off switch located on the rear of the lower cabinet.

2. Switch the DP2300 to the ON position.

Note: Initial temperature setting of 150°F has been shown to be acceptable for most dough formulations; however, you may have to determine the best temperature for your own dough by trial and error testing of your product at different temperature settings.

3. Set the timer in accordance with the following information:

2-4 seconds –For warm dough with moderate yeast content.

2-6 seconds – For room temperature dough with moderate yeast content.

6-8 seconds – For cold dough right out of the refrigerator with low yeast content.

Remember that the timer does not actuate until the upper platen mates with the lower platen and resistance is felt.

4. Set the thickness control lever to “thick” or “thin” or anywhere in between these settings as your product requires.

Note: Diameter and thickness is determined through experimenting with your own dough and is a product of dough weight, temperature, pressing time, and thickness setting.

5. Swing open the lower platen and apply a quick spray of a good *water based* food release on the

lower platen. Doughpro offers its own food release spray NATURALLY CLEAR Model No. DPPC1. (See our catalog and price list for information.)

*Note: This spray **will not** affect the taste of your crust in any way.*

6. Place your pre-portioned ball of dough in the approximate center of the lower platen. Add another dash of spray to the top of the dough ball.
7. Close the platen and, with both hands, press the two green buttons on each side of the machine simultaneously.
8. Hold the buttons in until resistance is felt then release at once. The timer will actuate and, when the time cycle is completed, the upper platen will rise automatically (timer is preset at factory for six (6) seconds, but this is easily changed by following the upcoming instructions.)
9. Remove the crust, place on a disc, screen, pan or peel, add toppings and bake.

Y CTPPI <

Serial Tags

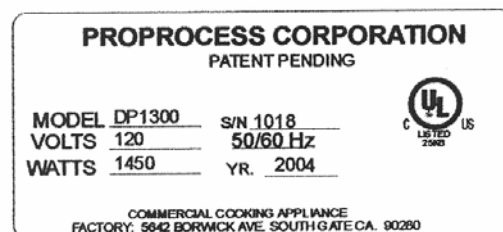

International Symbols



Power Off



Power On



Hot Surface



Protective Earth Terminal



Caution - Warning

Contact our factory or approved service agency (800) 624-6717 (U.S. only).

*Note: When contacting factory for information, parts or service instructions, it is of the **utmost importance** that the serial number of the machine be provided. This number can be found on the serial plate located on the rear of the machine.*

Preventative Maintenance Suggestions

The Doughpro DP2300 machines are relatively maintenance free. For a long and trouble-free life, the following preventative maintenance should be followed:

Daily Care:

1. ***Platens:*** Turn your machine off and allow to cool down before attempting to clean. These platens should *only* be cleaned with mild soap and warm water then wiped off with a clean, soft cloth or soft sponge. **Never use steel wool or harsh abrasives or you will cause costly damage.**
2. ***All other exterior surfaces:*** Here again a daily wipe down with mild soap and warm water will do the job quite nicely. **Never use steel wool or harsh abrasives or you will cause costly damage.**

Service Problems:

Piston Maintenance:

In order to ensure proper and trouble free operation of the press piston, it is important that the machine be lubricated once every three (3) months, under normal operation. High volume users may require more frequent lubrication.

The lubricant used must be USDA H-1 authorized for food machinery. This lubricant can be ordered through Proluxe as part number # 110-002. Please follow these simple instructions:

1. Locate the grease port on the machine. Machines with pull down arms have a single grease port located below the upper head on the right side of the vertical post. Machines with swing-away upper heads have two grease ports; one on the right side of the vertical post and one on the back of the vertical post. All other machines have a single port. (refer to illustration)
2. Place grease gun head against grease port and apply enough pressure to allow gun head to engage the grease port.
3. Squeeze handle of grease gun which forces the grease into the piston. **One squeeze is all it takes.**

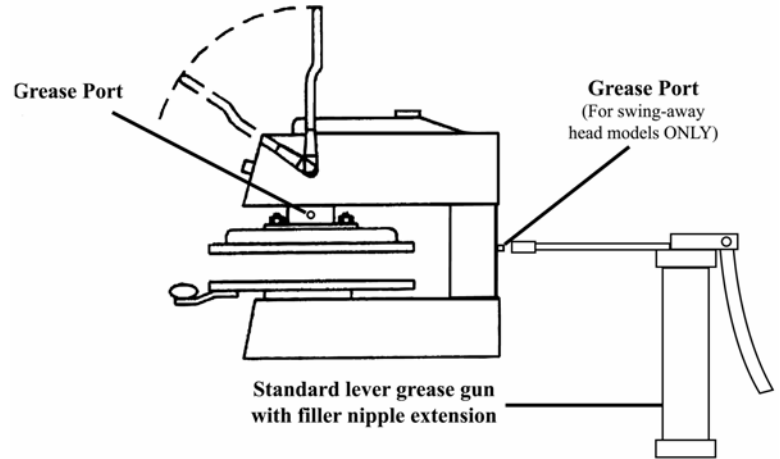

Service Problems:

Contact our factory or approved service agency (U.S. only). *Note: When contacting factory for information, parts or service instructions, it is of the **utmost importance** that the serial number of the machine be provided. This number can be found on the serial plate located on the rear of the machine.*

PROLUXE

DP2300BZ AUTOMATIC PIZZA PRESS

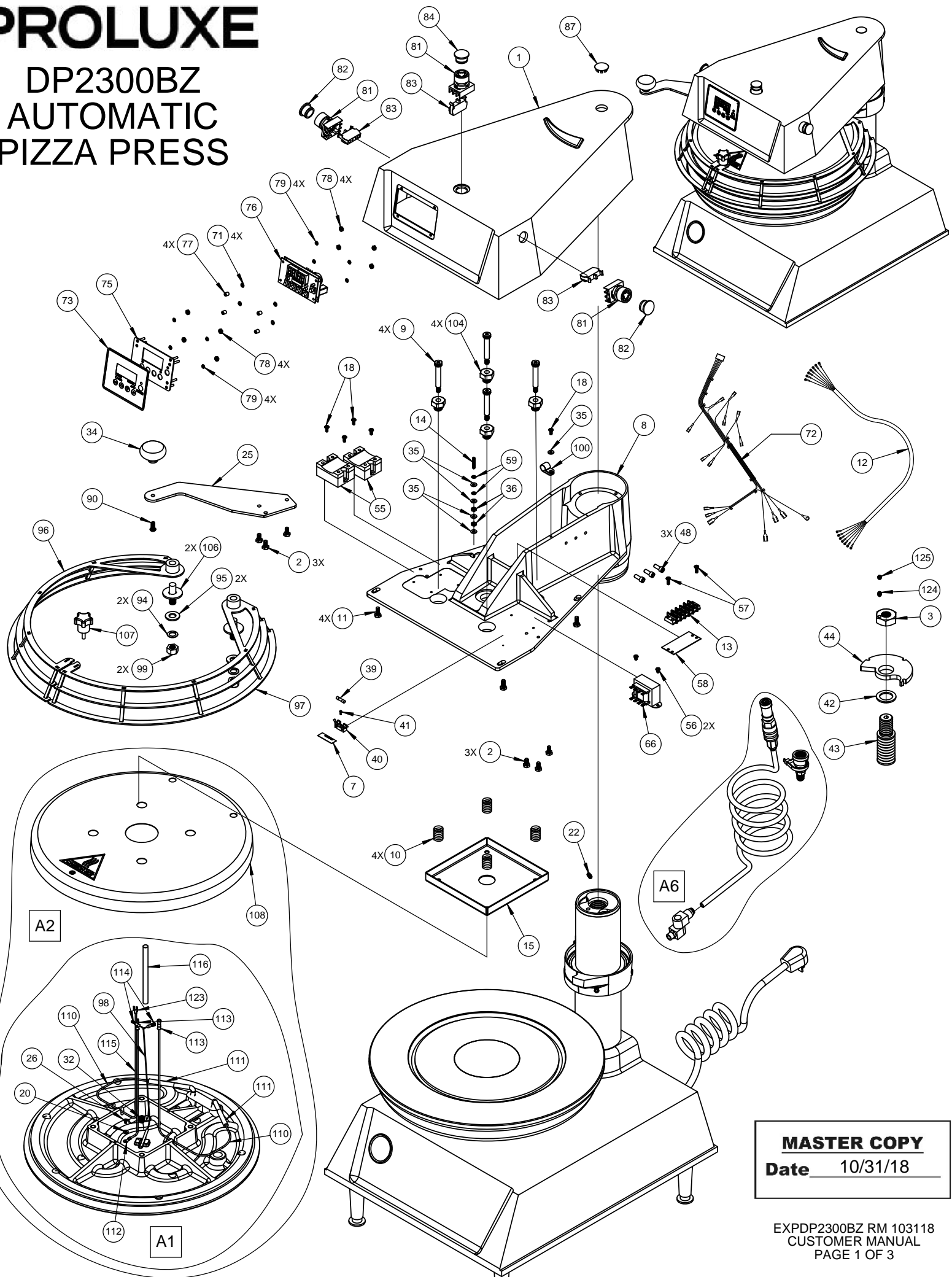

MASTER COPY
Date 10/31/18

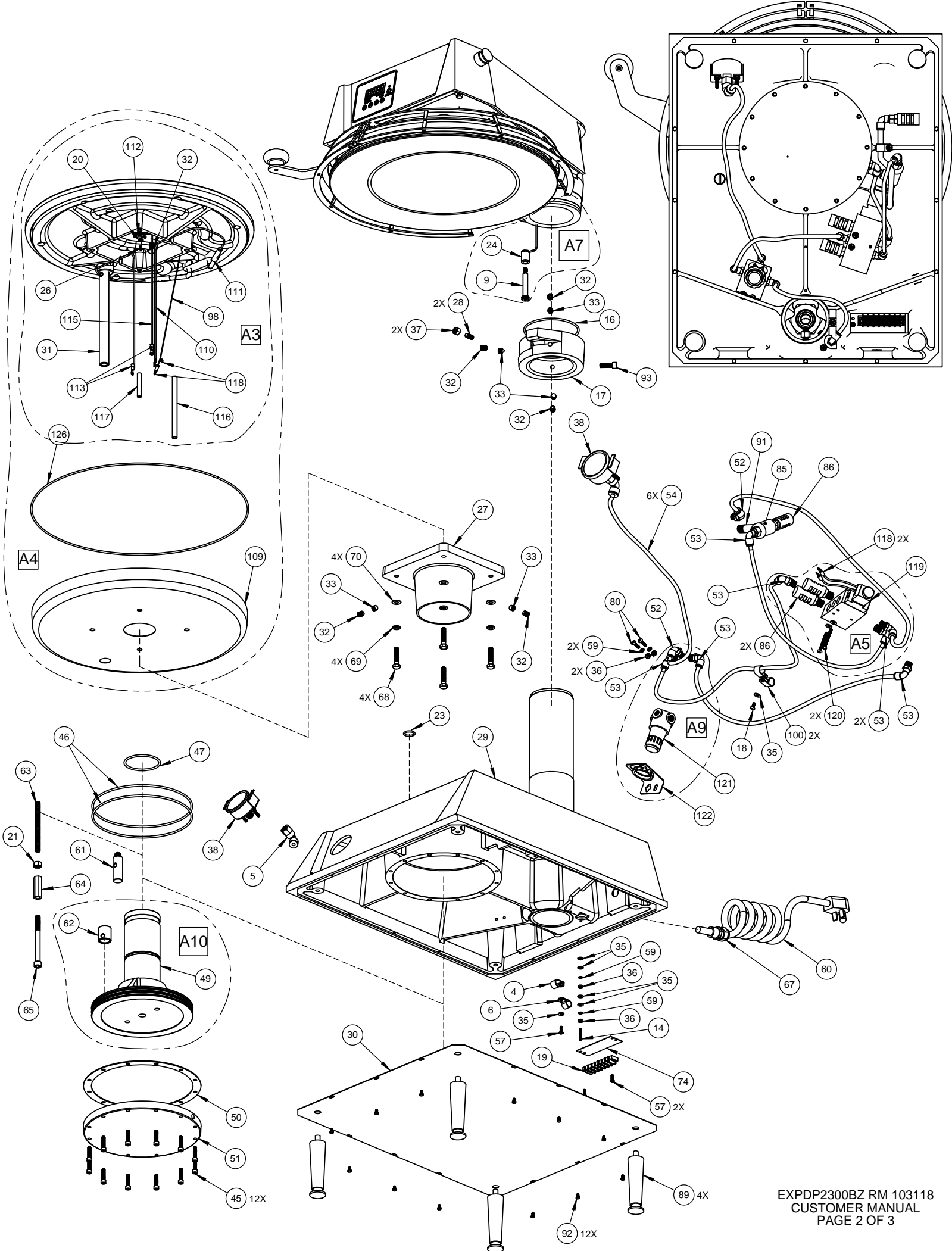

AIR TUBING DIAGRAM

REGULATE AIR PRESSURE
BETWEEN 50 AND 55 PSI.

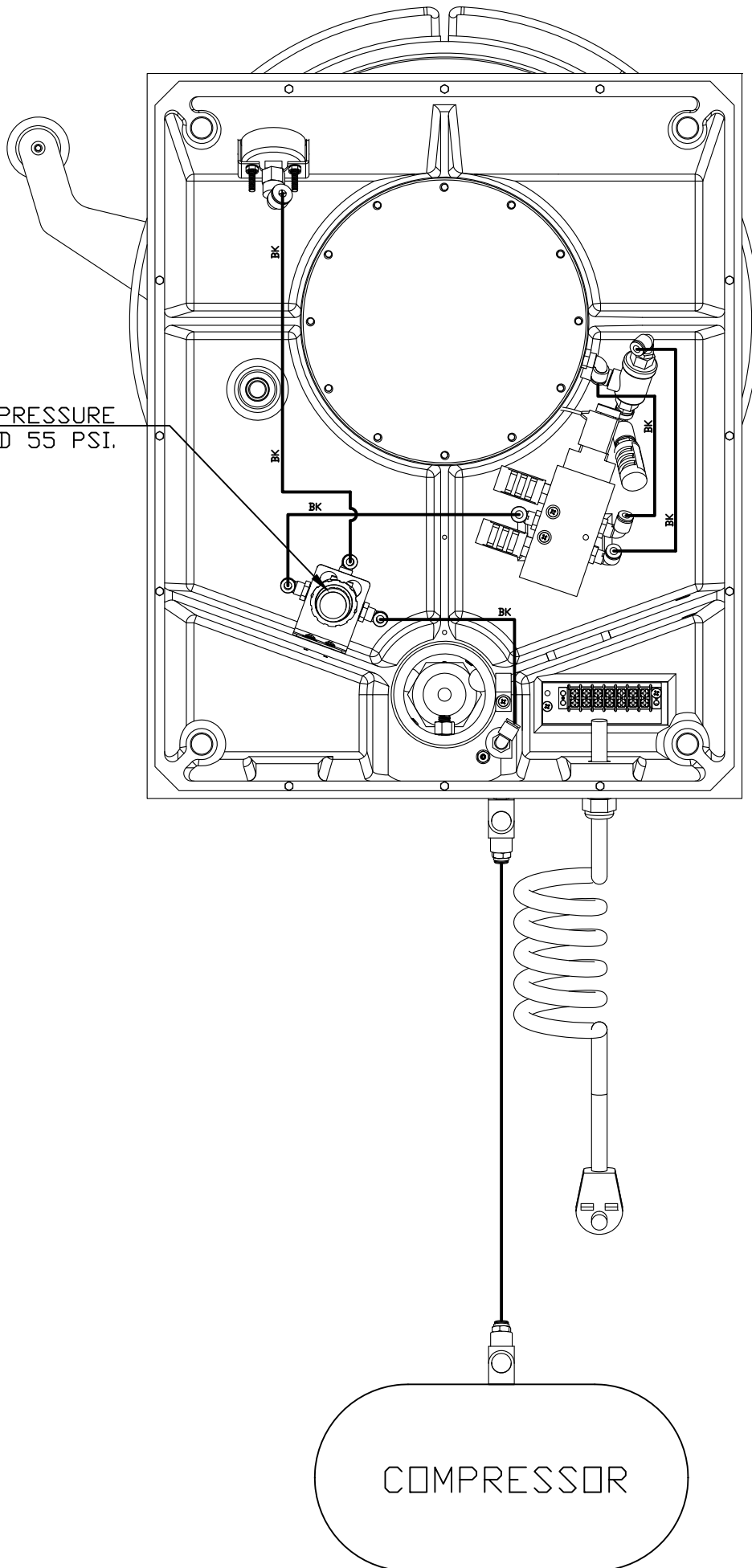

COMPRESSOR

**PROLUXE PARTS LIST FOR MODEL
DP2300BZ**

ITEM No.	DESCRIPTION	DP2300BZ 208 ~ AC	DP2300BZCEC 220 ~ AC	QTY.
1	HOUSING, INSTRUMENTAL	11010252201	11010252201	1
2	HEX BOLT STAINLESS STEEL, 1/4-20 X 1/2	BH142012S	BH142012S	3
3	NUT, LOCKING JAM (MACHINED)	11070	11070	1
4	CLAMP, CABLE 1/2	CC12	CC12	2
5	FITTING, AIR 1/4" FEMALE PIPE X, 1/4 TUBE 90 DEG.	AQ70P4X4	AQ70P4X4	1
6	CLAMP, CABLE 3/8	CC38	CC38	1
7	DECAL LABEL FUSE 2 MIL MYLAR 1 COLOR BLACK	DLFUSE	DLFUSE	1
8	ARM, MACHINED DP2300	11023002101	11023002101	1
9	BOLT, SHOULDER 3/8 x 2	11023003	11023003	5
10	SPRING, DIE RED MEDIUM HEAVY DUTY	11020106	11020106	4
11	BOLT, HEX 1/4-20 x 5/8	BH142058	BH142058	4
12	POWER DISTRIBUTION CABLE	110230068	110230068	1
13	TERMINAL BLOCK STAGE #5 DOUBLE	6015	6015	1
14	SCREW, SET 8-32 x 1	SST8321	SST8321	2
15	COVER, LEVELING SPRING	11023002	11023002	1
16	O-RING #2-243 N-70	MPSS062	MPSS062	1
17	POST COLLAR	1101751162301	1101751162301	1
18	SCREW, PAN HEAD PHILLIPS 8-32 x 3/8	SP83238	SP83238	6
19	TERMINAL BLOCK #7	6017	6017	1
20	WASHER, SAE #6	WSAE6	WSAE6	2
21	NUT, HEX 3/8-16	NH3816	NH3816	1
22	SCREW, SET 1/4-20 x 1/2	SST142012	SST142012	1
23	O-RING, SOFT BUNA-N	110230077	110230077	1
24	ALIGNMENT SWITCH ASSEMBLY	1101169341	1101169341	1
25	HANDLE, SWING AWAY	11023004501	11023004501	1
26	SCREW, PAN HEAD PHILLIPS 6-32 x 1/4	SP63214	SP63214	2
27	PISTON RAM MACHINED DP2300	11023003001	11023003001	1
28	COLLAR, STOP PIN	DP12504	DP12504	2
29	BASE ASSEMBLY	1102300BZ1102	1102300BZ1102	1
30	COVER PLATE, BASE	11054	11054	1
31	POST GUIDE DP2300	11023004	11023004	1
32	SCREW, SET 3/8-16 X 1/2"	SST381612	SST381612	7
33	SCREW, SET 3/8"-16 X 1/2", CONE POINT	SST381612CP	SST381612CP	5
34	KNOB SWING	110017	110017	1
35	WASHER, SAE #8	WSAE8	WSAE8	11
36	NUT, HEX 8-32	NH832	NH832	6
37	NUT, HEX JAM 5/16-18	NHJ51618	NHJ51618	2
38	2" BLK/BRS AIR GAUGE	110130007	110130007	1
39	FUSE BUSS 1 AMP	MPPF701R	MPPF701R	1
40	FUSE HOLDER	MPPF708	MPPF708	1
41	SCREW, PAN HEAD PHILLIPS 2-56 x 1/4	SP25614	SP25614	1
42	THRUST WASHER	11059	11059	1
43	ADJUSTMENT SCREW	110230042	110230042	1
44	THRUST PLATE	DP15404	DP15404	1
45	SCREW, SOCKET HEAD CAP, 1/4-20 x 1	SSH14201D	SSH14201D	12
46	O-RING	MPSR138	MPSR138	2
47	O-RING PISTON ROD	62308	62308	1
48	SCREW, SOCKET HEAD 1/4-20 X 3/4	SSH142034	SSH142034	3
49	PISTON ASSEMBLY	110230039	110230039	1
50	GASKET, PISTON 8"	MPSG140	MPSG140	1
51	PISTON, COVER	11013	11013	1
52	FITTING, AIR 1/8" PIPE x 1/4" TUBE, 90 DEGREE	AQ69P4X2	AQ69P4X2	2
53	FITTING, AIR 1/4" PIPE x 1/4" TUBE 90°	AQ69P4X4	AQ69P4X4	7
54	TUBING, BLACK AIR LINE 1/4	TPE4014	TPE4014	5.125 FT
55	RELAY, SOLID STATE	MPR90217	MPR90217	2
56	SCREW, PAN HEAD PHILLIPS 8-32 x 1/4	SP83214	SP83214	2
57	SCREW, PAN HEAD PHILLIPS 8-32 x 1/2	SP83212	SP83212	5
58	MARKER STRIP #5	MS6015	MS6015	1
59	WASHER, INTERNAL TOOTH LOCK #8	WLIT8	WLIT8	6

**PROLUXE PARTS LIST FOR MODEL
DP2300BZ**

ITEM No.	DESCRIPTION	DP2300BZ 208 ~ AC	DP2300BZCEC 220 ~ AC	QTY.
60	POWER CORD	110573175	MPPW202	1
61	GUIDE PISTON POST	11072	11072	1
62	BUSHING, GUIDE POST	MPSB070	MPSB070	1
63	ROD, THREADED	110230016	110230016	1
64	NUT, COUPLING 3/8-16 x 1-3/4	NC3816134	NC3816134	1
65	SCREW, SOCKET HEAD 3/8-16 x 4	SSH38164	SSH38164	1
66	TRANSFORMER	11096975	MPPT700R	1
67	STRAIN RELIEF	3231	3231	1
68	BOLT, HEX 5/16-18 x 1-1/2 PARTIALLY TREADED	BH51618112G5	BH51618112G5	4
69	WASHER SPLIT LOCK 5/16	WL516	WL516	4
70	WASHER, SAE 5/16	WSAE516	WSAE516	4
71	WASHER, STEEL .311 O.D. x .150 I.D. x .020 THICK	311150019	311150019	4
72	WIRE HARNESS	DP15450	DP15450	1
73	CONTROL PANEL OVERLAY	ODP1300BZ	ODP1300BZ	1
74	MARKER STRIP #7	MS6017	MS6017	1
75	FACIA CONTROL PLATE	11086027	11086027	1
76	CONTROL, DIGITAL	110175116052	110175116052	1
77	SPACER, NYLON	110969111	110969111	4
78	NUT, HEX 6-32	NH632	NH632	8
79	WASHER, INTERNAL TOOTH LOCK #6	WLIT6	WLIT6	8
80	SCREW, PAN HD 8-32 X 5/8"	SP83258	SST381612	2
81	SWITCH, MOM P/S OP SCREW ON GE	P9XPLOSO	P9XPLOSO	3
82	GREEN MUSHROOM BUTTON SCREW ON	P9ARB3V	P9ARB3V	2
83	CONTACT N/O SCREW TYPE, GE #P9B10VN	110101751	110101751	3
84	BUTTON BLACK MUSHROOM SCREW ON GE	P9ARB3N	P9ARB3N	1
85	VALVE, QUICK EXHAUST	110559033	110559033	1
86	MUFFLER, 1/4 SUPER QUITE FLOW	110559029	110559029	3
87	PLUG, BUTTON 7/8, PLASTIC (BLACK)	PB78P	PB78P	1
89	LEG, APPLIANCE, 4", SATIN NICKEL FINISH	AE601653	AE601653	4
90	SCREW, BUTTON HEAD 1/4-20 X 5/8	SB142058	SB142058	1
91	NIPPLE, BRASS 1/4 x 2	N142	N142	1
92	BOLT HEX SLOTTED 8-32 x 1/4	BH83214	BH83214	12
93	SCREW, SOCKET HEAD 5/16-18 X 1 DOMESTIC	SSH516181D	SSH516181D	1
94	WASHER, LOCK SPLIT 1/2"	WL12	WL12	2
95	WASHER, SAE 1/2"	WSAE12	WSAE12	2
96	GUARD, LEFT SIDE BURN	11017452306	11017452306	1
97	GUARD, RIGHT SIDE BURN	11017452307	11017452307	1
98	RTD SENSOR ASSEMBLY	110949110	110949110	2
99	NUT, HEX 1/2-13	NH1213	NH1213	2
100	CLAMP, CABLE 5/16	CC516	CC516	2
104	U.P. ADJUSTMENT BOLT	DP15467	DP15467	4
105	MANUAL DP2300 (BLAZE)	MDP2300BZ	MDP2300BZCEC	1
106	SHAFT, WELDMENT	11017452309	11017452309	2
107	KNOB	KN113	KN113	1
108	UPPER HEAT SHROUD WELDING	110230061	110230061	1
109	SHROUD, LOWER PLATEN	110230037	110230037	1
110	WIRE, TGGT, 14 GA	110069	110069	13.25 FT
111	TFE, SHRINK TUBING 7 AWG	110131	110131	.66 FT
112	TERMINAL, RING #6 14-16 GA (HI-TEMP)	1601HT	1601HT	2
113	TERMINAL, RING #8 14-16 GA (BLUE)	1604	1604	4
114	TERMINAL, QD 3/16 x 18-22 GA (PINK)	2280	2280	2
115	WIRE, TFE 14 GA GREEN	WTFE14G	WTFE14G	5.45 FT
116	SLEEVEING, PVC WIRE	OPVC1050	OPVC1050	1.91 FT
117	TFE NON SHRINK TUBING	110133	110133	.50 FT
118	TERMINAL, RING #6 x 18-22 GA, RED MOLEX	2202	2202	4
119	VALVE SOLENOID	11017511604	11017511604	1
120	SCREW, PAN HEAD 8-32 x 1-1/2 STAINLESS STEEL	SP832112S	SP832112S	2
121	AIR REGULATOR, DP2300	110130004	110130004	1
122	MOUNTING BRACKET REGULATOR AND PANEL NUT PLASTIC	110130005	110130005	1

**PROLUXE PARTS LIST FOR MODEL
DP2300BZ**

ITEM No.	DESCRIPTION	DP2300BZ 208 ~ AC	DP2300BZCEC 220 ~ AC	QTY.
123	14-16 GA #10 FORK TERMINAL ISUL.	1626	1626	2
124	SCREW, SET 1/4-20 X 3/8 CONE POINT	SST142038CP	SST142038CP	1
125	SCREW, SET 1/4-20 X 1/4	SST142014	SST142014	1
126	O-RING GASKET	DP18302	DP18302	1
A1	KITTED, UPPER PLATEN WITH WIRING ONLY	11017452374208K	11017452374220K	1
A2	KITTED, UPPER PLATEN COMPLETE ASSEMBLY	11017452374208AK	11017452374220AK	1
A3	KITTED, LOWER PLATEN WITH WIRING ONLY	11017452332208K	11017452332220K	1
A4	KITTED, LOWER PLATEN COMPLETE ASSEMBLY	11017452332208AK	11017452332220AK	1
A5	KITTED, SOLENOID VALVE ASSEMBLY	11017511604K	11017511604K	1
A6	AIR LINE EXTERNAL SYSTEM	110230010	110230010	1
A7	ALIGNMENT SWITCH ASSY KIT	1101169341K	1101169341K	1
A8	KITTED, MOUNTING TEMPLATE	DP127K	DP127K	1
A9	REGULATOR, GAUGE AND FITTING KIT	DP15405K	DP15405K	1
A10	KITTED, PISTON ASSY	110230039K	110230039K	1

VAC: 208 VAC
 AMPS: 22.12A
 WATTS: 4600W

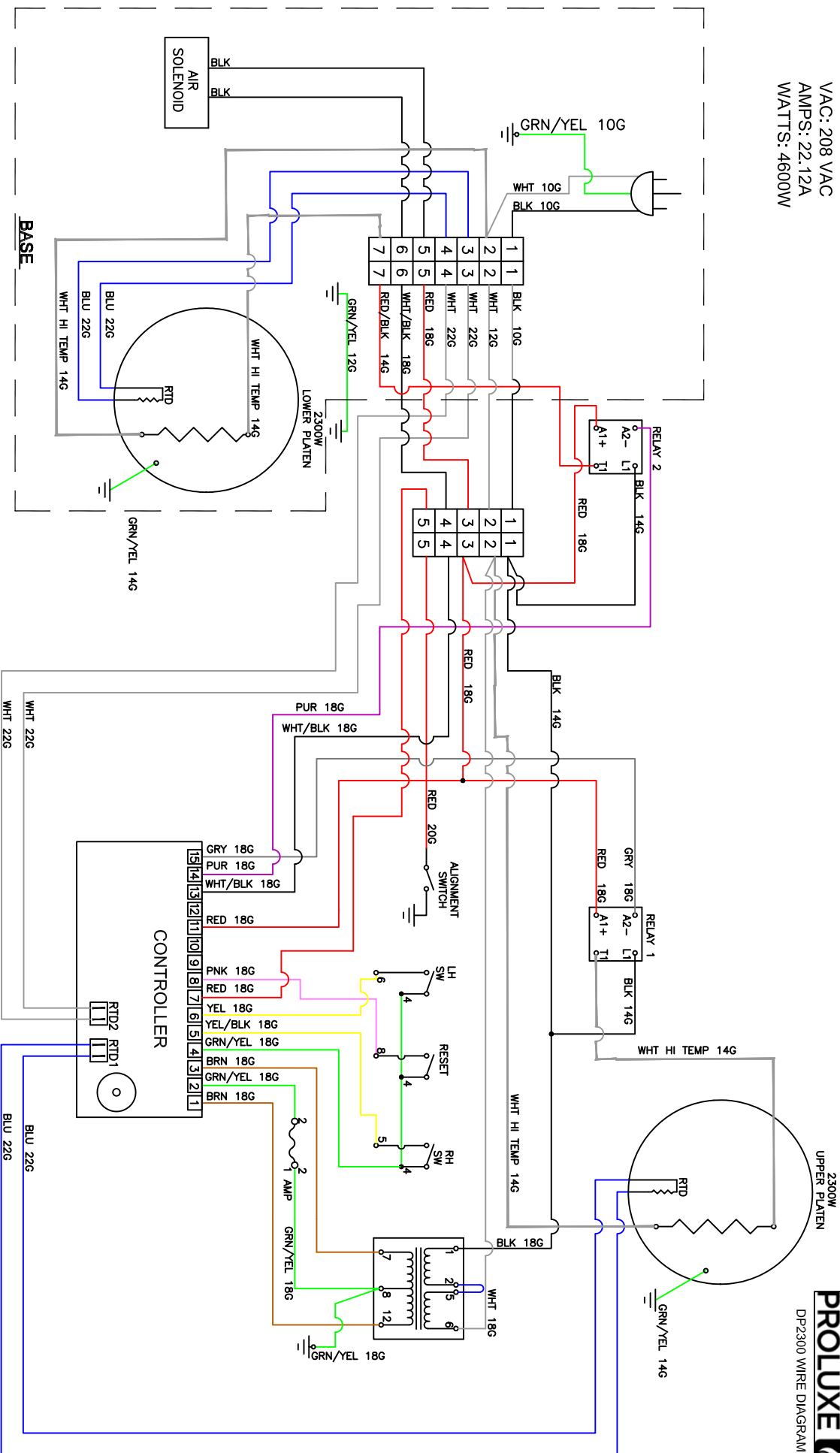

MASTER COPY
 Date 05/02/17

ARM

WDDP2300 RH 61058

DOUGHPRO

DP2300 Automatic Air Press Trouble Shooting Guide

Symptom	Probable Cause	Action to be Taken	Ref. #'s on Explosion Drawing
Power Button on Digital Controller face is depressed but doesn't turn on.	Power Cord is not plugged in.	Plug power cord into wall 's receptacle and depress power button on controller	60
	Circuit Breaker is tripped off in the site's breaker box	Reset circuit breaker that the Grill is plugged into. Depress Power Button to turn on.	—
	Transformer has taken a electrical surge and is damaged	Replace Transformer after you check secondary side of transformer. If working properly, you should receive 12vdc.	66
	Check voltage on the secondary side of the Transformer. If you read 12VDC then you are receiving voltage to the Controller.	Replace Controller. Controller should be on once the power button is depressed.	76
	Possibly blown Fuse	Replace fuse.	39
Digital Controller's LED's are scrambled or randomly erratic. If when turning on, the display will first go to segment check	Possibly a componet on the Digital Controller is damaged	Replace Digital Controller	76
	Possibly control needs to reset	While unit is on (controller lit up) Unplug unit, wait for 1 min. then plug machine on and depress power button.	—
Digital Controller on startup goes through LED segment check (8888) then to version # and then loops back to to the above reboot.	The relay driver on the digital control may be blown.	Replace Digital Controller.	76
Digital display shows PROB. No heat on Upper Platen.	Sensor lost it's continuity as shown on a muti-meter.	Disconnect prob that is open (no continuity as shown on a multi-meter. Must replace Sensor (RTD). Do not cut and splice new sensor. Install new 2000 ohm RTD sensor to under side of Heat Platen and reconnect to Controller.	A1.10
When depressing the tactile button on Digital Controller, nothing happens.	The tactile buttons under the overlay may be not close enough to activate. Same goes if the buttons are already pressed by overlay without depressing button.	Carefully (no too much at one time to avoid fracturing the traces on the Controller) tighten the nuts on the back of the Controller until button activate. Same goes in reverse if buttons are held down by the overlay.	—
Digital display shows Rela and Particular zone is over heating or outer zone).	The Relay on the switched side is not opening to regulate temperture.	Replace the Relay.	55
Beeper not functioning or intermitten beeper sound.	Beeper on Digital Control board failed.	Replace Digital Controller board	76

DOUGHPRO

DP2300 Automatic Air Press Trouble Shooting Guide

Symptom	Probable Cause	Action to be Taken	Ref. #'s on Explosion Drawing
If setpoint is reached but slightly off in temperature.	Offset may need to be calibrated and adjusted.	Must call (800) 624-6717 ext. 129 for confidential instructions.	—
Press does not close when pressing the two, green, start buttons	Did not simultaneously press the start buttons exactly at the same time	Try pressing both buttons exactly at the same time. This is a anti-tie-down safety feature.	82
	The Lower Platen switch mounted on the base is not in contact to complete circuit	Make sure the roller plunger comes into contact (clicking noise). This is also a safety feature that both platens are aligned before	
Heater Platen overheating	If the Relay (depending the year of the model) on the coil side are receiving 12vdc indicates the Controller is functioning properly. On the switching side of the relay, is there 120 vac going to the heater in question . If there is no voltage on the to the switching side of the relay to the heaters, the Relay is not working properly	Replace Relay If the Controller's heat-on LED is not lit indicating the controller is working properly.	55
Power is on but hear a leaking of air under the lower platen / Ram casting while Press is idle.	The O'rings are worn allowing the air to pass through the cylinder. This occurs when the cylinder walls loses it's lubrication due to excessive water generated by poorly maintained compressor or undersized compressor generating heat thus generating water. Be sure to drain captured water from compressor tank on a regular basis.	The cylinder needs orings, gasket and new cylinder grease. Request instruction sheet and need to order P/N 110033 for the kit.	—
After activation Lower Platen and when cycle is complete, the Lower Platen either is very slow coming down or doesn't go up or down at all.	The Mufflers on the Solenoid Valve maybe dirty and now allowing air from passing though. This occurs when excess water is passing from the compressor to the press. If this doesn't correct the problem. You may need to replace the solenoid valve.	Replace both Solenoid Valve mufflers.	A5.2
Both Upper and Lower Platen not aligned when activating. You may experience a shifting of the platens when coming into contact, or striking noise.	Upper and Lower Platen misaligned.	On the left side of the Post Collar (#35) are back- to-back set screws. Remove the first locking set screw. Adjust stopping set screw to align platen (*IMPORTANT* must reduce air pressure to a minimum as not to damaging closing platens). After alignment is complete, re-install locking set screw as not to move the alignment set screw.	17

Warranty & Return Policy

Proluxe warrants all products manufactured by it against defects in workmanship or materials from the date of purchase for a period of (1) year on parts and **labor**. **This warranty applies to only equipment purchased and used in the United States.** Warranty period shall begin when equipment ships. Warranty travel shall only be covered for 60 miles. Limited lifetime warranty on heating elements.

ALL WARRANTY SERVICE CALLS MUST BE APPROVED BY PROLUXE. IF THIS PROCEDURE IS NOT FOLLOWED, WARRANTY SERVICE WILL NOT BE COVERED. WARRANTY SERVICE WILL BE PAID ON STRAIGHT TIME, OVERTIME WILL NOT BE COVERED.

Exclusions:

- 1. WOOD / GAS FIRED OVENS:** PROLUXE warranty applies to the main body of the oven being steel / refractory and insulation shall be free from defects in materials and workmanship for a period of four years from the date of purchase. The gas equipment shall be free from defects in materials and workmanship for a period of one (1) year from the date of purchase. Lifetime warranty against cracks on oven floor.
- 2. Air compressors are excluded from this warranty,** but PROLUXE may act as a warranty expeditor in certain instances regarding these compressors. The air compressor manufacturer provides a limited warranty and a copy of this warranty is furnished with all compressors sold by PROLUXE. For prompt handling of compressor warranty claims the instructions of the compressor manufacturer must be adhered to.
- 3. Equipment built to special order as well as accessories** cannot be canceled and are not returnable unless defective within the terms of this warranty.
- 4. In no event shall PROLUXE be liable for consequential damages arising out of the failure of any of its products if operated improperly, altered or caused by normal wear or damage by operator abuse.**
- 5. BC2325 pedestal warranty disclaimer:** Pedestals shall only be covered under warranty if they have been cleaned using the factory approved cleaning method. Cracked or damaged pedestals must be inspected by the factory before warranty is authorized.
- 6. Limited lifetime warranty on heating elements:** If replacement is needed, Proluxe will send the new part at no charge but **labor** will not be covered unless the unit is still under the 1 year manufacture warranty.

Returned Merchandise Policy:

Should it become necessary to return any of the company's products, the following instructions must be adhered to: First, contact our customer service department for approval and a return authorization number. *Please have the serial number of your item available at that time.* All merchandise must be shipped *freight prepaid* by customer or service agency. Subject to the inspection of the product by the company, a restocking charge of 20% of the Net purchased price paid to PROLUXE will be assessed. Merchandise may not be returned for credit without *prior written approval* of PROLUXE. Collect shipments *will not* be accepted. No returns after 60 days of original shipment date on machines. Purchased parts may not be returned after 30 days.

If upon inspection by PROLUXE or its authorized agent it is determined the equipment has not been used in an appropriate manner, has been modified, or has not been properly maintained, or has been subject to misuse, misapplication, neglect, abuse, accident, unauthorized modification, damage during transit, delivery, fire, flood, act or war, riot or act of God, then this warranty shall be deemed null and void.

Terms & Conditions:

1. Prices indicated in the PRICE LIST are suggested retail prices and are shown in U.S. DOLLARS.
2. Terms of Payment: 1% 10 days, NET 30 days.
3. **NEW ACCOUNTS:** Satisfactory credit information must be provided before open account status can be extended. Unless agreed otherwise, all shipments will be made C.O.D., CASH IN ADVANCE.
4. **PRICING:** Prices, specifications, model numbers, capacities and accessories are subject to change without notice.
5. **FREIGHT / ROUTING:** Method of shipment will be determined by PROLUXE unless otherwise advised by PURCHASER.
6. **DAMAGED CLAIMS:** All merchandise shipped at purchaser's risk. Inspection must be made by purchaser at time goods are received. If goods are damaged, the PURCHASER shall request that the agent of the transportation company make a written notation on the proper shipping documents immediately and then file a claim for damage. **GOODS DAMAGED IN SHIPMENT ARE NOT RETURNABLE.**
7. **RETURNS:** Machines may not be returned after 60 days. Purchased parts may not be returned after 30 days. A restocking fee of 20% will be assessed on non-warranty returns.
8. **TAXES:** Prices indicated herein DO NOT include State, Federal, Local or foreign taxes or duties, nor do they include fees, permits, insurance or other levies, all of which are the responsibility of the purchaser.
9. All orders are subject to acceptance by PROLUXE.
10. Possession of this price list shall not be considered an offer to sell.