

SERVICE MANUAL

| MODEL | JP | E3 | E2 | EK | E2A | E1C | E1K | EUT |
|-----------------|----|----|----|----|-----|-----|-----|-----|
| S-52 | ✓ | ✓ | ✓ | | | | | |
| S-52 DAB | | | | ✓ | | | | |

WIRELESS NETWORK CD MUSIC SYSTEM

| MODEL | JP | E3 | E2 | EK | E2A | E1C | E2K | EUT |
|-------------|----|----|----|----|-----|-----|-----|-----|
| S-32 | | ✓ | ✓ | | | | | |

WIRELESS NETWORK MUSIC SYSTEM

注意

サービスをおこなう前に、このサービスマニュアルを必ずお読みください。本機は、火災、感電、けがなどに対する安全性を確保するために、さまざまな配慮をおこなっており、また法的には「電気用品安全法」にもとづき、所定の許可を得て製造されております。従ってサービスをおこなう際は、これらの安全性が維持されるよう、このサービスマニュアルに記載されている注意事項を必ずお守りください。

• For purposes of improvement, specifications and design are subject to change without notice.

• 本機の仕様は性能改良のため、予告なく変更することがあります。
• 補修用性能部品の保有期間は、製造打切後 8 年です。

• Please use this service manual with referring to the operating instructions without fail.

• 修理の際は、必ず取扱説明書を参照の上、作業を行ってください。

• Some illustrations using in this service manual are slightly different from the actual set.

• 本文中に使用しているイラストは、説明の都合上現物と多少異なる場合があります。

DENON

Denon Brand Company, D&M Holdings Inc.

SAFETY PRECAUTIONS

The following check should be performed for the continued protection of the customer and service technician.

LEAKAGE CURRENT CHECK

Before returning the unit to the customer, make sure you make either (1) a leakage current check or (2) a line to chassis resistance check. If the leakage current exceeds 0.5 milliamps, or if the resistance from chassis to either side of the power cord is less than 460 kohms, the unit is defective.

LASER RADIATION

Do not stare into beam or view directly with optical instruments, class 3A laser product.

CAUTION Please heed the points listed below during servicing and inspection.

◎ Heed the cautions!

Spots requiring particular attention when servicing, such as the cabinet, parts, chassis, etc., have cautions indicated on labels or seals. Be sure to heed these cautions and the cautions indicated in the handling instructions.

◎ Caution concerning electric shock!

(1) An AC voltage is impressed on this set, so touching internal metal parts when the set is energized could cause electric shock. Take care to avoid electric shock, by for example using an isolating transformer and gloves when servicing while the set is energized, unplugging the power cord when replacing parts, etc.

(2) There are high voltage parts inside. Handle with extra care when the set is energized.

◎ Caution concerning disassembly and assembly!

Though great care is taken when manufacturing parts from sheet metal, there may in some rare cases be burrs on the edges of parts which could cause injury if fingers are moved across them. Use gloves to protect your hands.

◎ Only use designated parts!

The set's parts have specific safety properties (fire resistance, voltage resistance, etc.). For replacement parts, be sure to use parts which have the same properties. In particular, for the important safety parts that are marked  on wiring diagrams and parts lists, be sure to use the designated parts.

◎ Be sure to mount parts and arrange the wires as they were originally!

For safety reasons, some parts use tape, tubes or other insulating materials, and some parts are mounted away from the surface of printed circuit boards. Care is also taken with the positions of the wires inside and clamps are used to keep wires away from heating and high voltage parts, so be sure to set everything back as it was originally.

◎ Inspect for safety after servicing!

Check that all screws, parts and wires removed or disconnected for servicing have been put back in their original positions, inspect that no parts around the area that has been serviced have been negatively affected, conduct an insulation check on the external metal connectors and between the blades of the power plug, and otherwise check that safety is ensured.

(Insulation check procedure)

Unplug the power cord from the power outlet, disconnect the antenna, plugs, etc., and turn the power switch on. Using a 500V insulation resistance tester, check that the insulation resistance between the terminals of the power plug and the externally exposed metal parts (antenna terminal, headphones terminal, microphone terminal, input terminal, etc.) is 1MΩ or greater. If it is less, the set must be inspected and repaired.

CAUTION Concerning important safety parts

Many of the electric and structural parts used in the set have special safety properties. In most cases these properties are difficult to distinguish by sight, and using replacement parts with higher ratings (rated power and withstand voltage) does not necessarily guarantee that safety performance will be preserved. Parts with safety properties are indicated as shown below on the wiring diagrams and parts lists in this service manual. Be sure to replace them with parts with the designated part number.

(1) Schematic diagrams ... Indicated by the  mark.

(2) Parts lists ... Indicated by the  mark.

Using parts other than the designated parts could result in electric shock, fires or other dangerous situations.

注意 サービス、点検時にはつぎのことにご注意願います。

◎注意事項をお守りください！

サービスのとき特に注意を必要とする個所についてはキャビネット、部品、シャーシなどにラベルや捺印で注意事項を表示しています。これらの注意書きおよび取扱説明書などの注意事項を必ずお守りください。

◎感電に注意！

(1) このセットは、交流電圧が印加されていますので通電時に内部金属部に触れると感電することがあります。従って通電サービス時には、絶縁トランスの使用や手袋の着用、部品交換には、電源プラグを抜くなどして感電にご注意ください。

(2) 内部には高電圧の部分がありますので、通電時の取扱には十分ご注意ください。

◎分解、組み立て作業時のご注意！

板金部品の端面の『バリ』は、部品製造時に充分管理しておりますが、板金端面は鋭利となっている箇所がありますので、部品端面に触れたまま指を動かすとまれに怪我をする場合がありますので十分注意して作業して下さい。手の保護のために手袋を着用してください。

◎指定部品の使用！

セットの部品は難燃性や耐電圧など安全上の特性を持ったものとなっています。従って交換部品は、使用されていたものと同じ特性の部品を使用してください。特に配線図、部品表に  印で指定されている安全上重要な部品は必ず指定のものをご使用ください。

◎部品の取付けや配線の引きまわしは、元どおりに！

安全上、テープやチューブなどの絶縁材料を使用したり、プリント基板から浮かして取付けた部品があります。また内部配線は引きまわしやクランプによって発熱部品や高圧部品に接近しないように配慮されていますので、これらは必ず元どおりにしてください。

◎サービス後は安全点検を！

サービスのために取り外したねじ、部品、配線などが元どおりになっているか、またサービスした個所の周辺を劣化させてしまったところがないかなどを点検し、外部金属端子部と、電源プラグの刃の間の絶縁チェックをおこなうなど、安全性が確保されていることを確認してください。

(絶縁チェックの方法)

電源コンセントから電源プラグを抜き、アンテナやプラグなどを外し、電源スイッチを入れます。500V 絶縁抵抗計を用いて、電源プラグのそれぞれの端子と外部露出金属部 [アンテナ端子、ヘッドホン端子、マイク端子、入力端子など] との間で、絶縁抵抗値が 1 MΩ 以上であること、この値以下のときはセットの点検修理が必要です。

注意 安全上重要な部品について

本機に使用している多くの電気部品、および機構部品は安全上、特別な特性を持っています。この特性はほとんどの場合、外観では判別つきにくく、またもとの部品より高い定格（定格電力、耐圧）を持ったものを使用しても安全性が維持されるとは、限りません。安全上の特性を持った部品は、このサービスマニュアルの配線図、部品表につぎのように表示していますので必ず指定されている部品番号のものを使用願います。

(1) 配線図…  マークで表示しています。

(2) 部品表…  マークで表示しています。

指定された部品と異なるものを使用した場合には、感電、火災などの危険を生じる恐れがあります。

DIMENSION

S-52/S-32

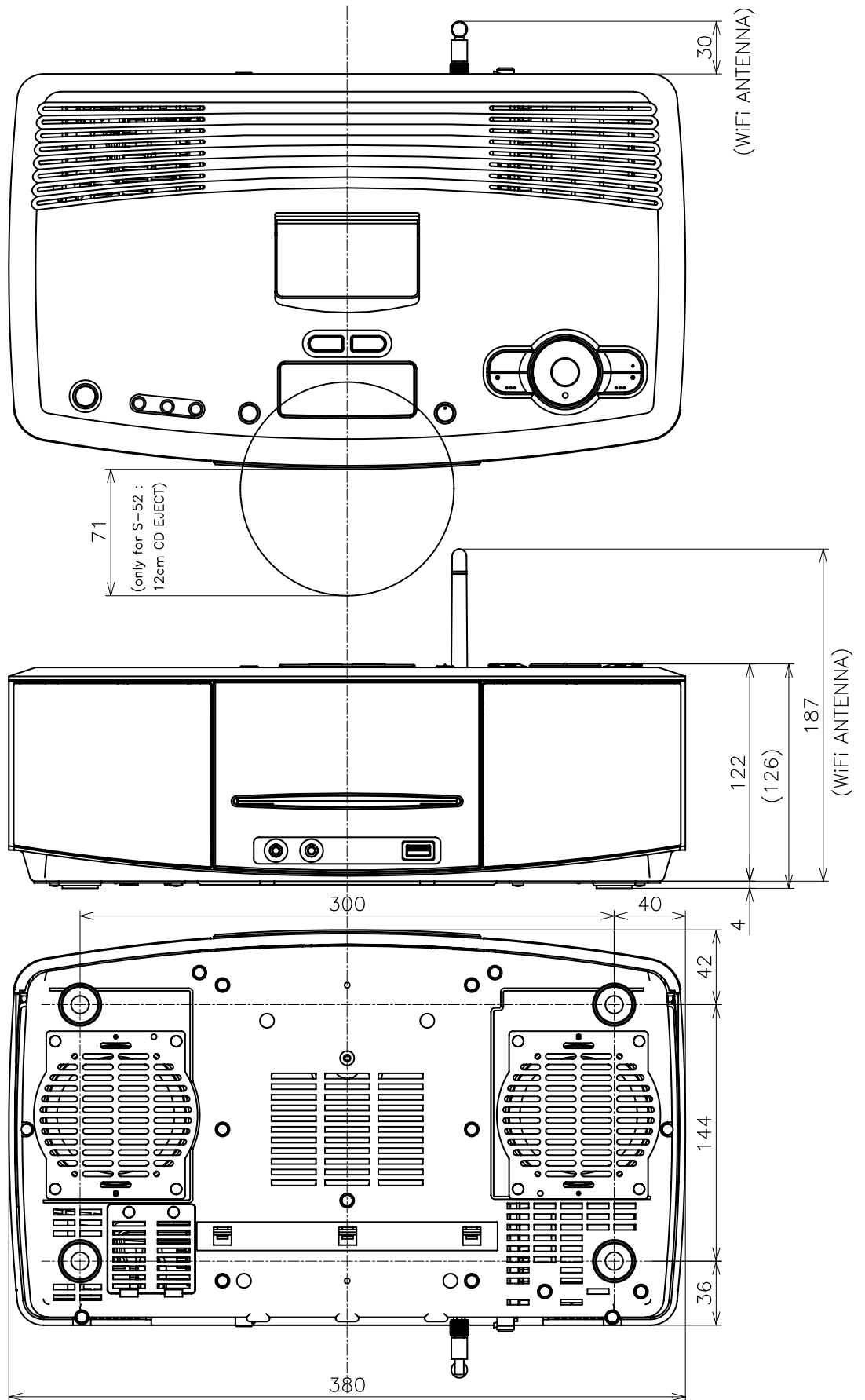

WIRE ARRANGEMENT

If wire bundles are untied or moved to perform adjustment or parts replacement etc., be sure to rearrange them neatly as they were originally bundled or placed afterward. Otherwise, incorrect arrangement can be a cause of noise generation.

1. MAIN UNIT

- ① a, Fasten the CX111 11P PH-PH CON.CORD and CX051 5P PH-PH CON.CORD to the circuit board with a style pin and clamp band. (S-52E3/E2/JP, S-32E3/E2)
- ① b, Fasten the CX111 11P PH-PH CON.CORD and CX051 5P PH-PH CON.CORD, CX081 8P PH-PH SHIELD CORD to the circuit board with a style pin and clamp band. (S-52DABEK)
- ② Fasten the 9P PH-PN SHIELD CORD to the circuit board with a style pin, and arrange the wire along the SIDE BRACKET.

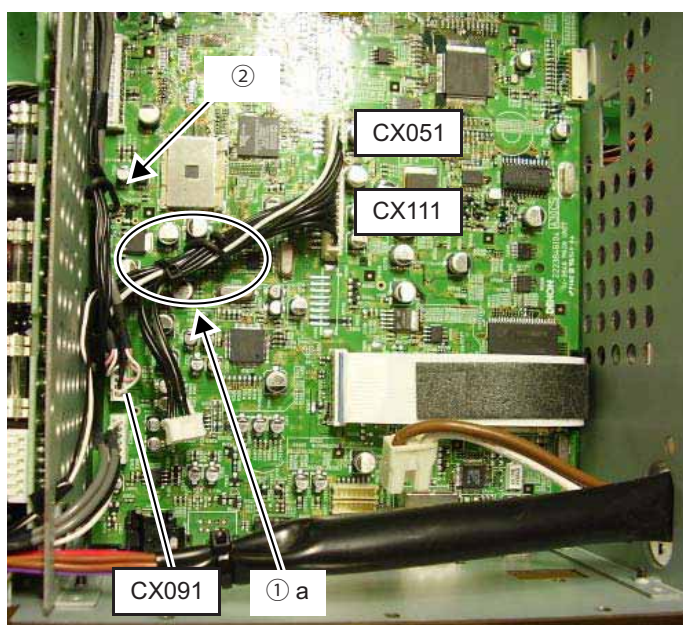

S-52E3/E2/JP, S-32E3/E2

ワイヤー整形図

調整や部品の交換等により、ワイヤー類の結束をはずしたり移動させた場合には、それらの作業が完了した時点でワイヤーの整形をおこなってください。正しく整形されてないとノイズ発生の原因となることがあります。

1. MAIN UNIT 部

- ① a, CX111 11P PH-PH CON.CORD と CX051 5P PH-PH CON.CORD をスタイルピンとクランプバンドで基板に固定する。(S-52E3/E2/JP, S-32E3/E2)
- ① b, CX111 11P PH-PH CON.CORD と CX051 5P PH-PH CON.CORD と CX081 8P PH-PH SHIELD CORD をスタイルピンとクランプバンドで基板に固定する。(S-52DABEK)
- ② CX091 9P PH-PN SHIELD CORD をスタイルピンで固定し、サイドブラケットに沿わせるようにワイヤーを整形する。

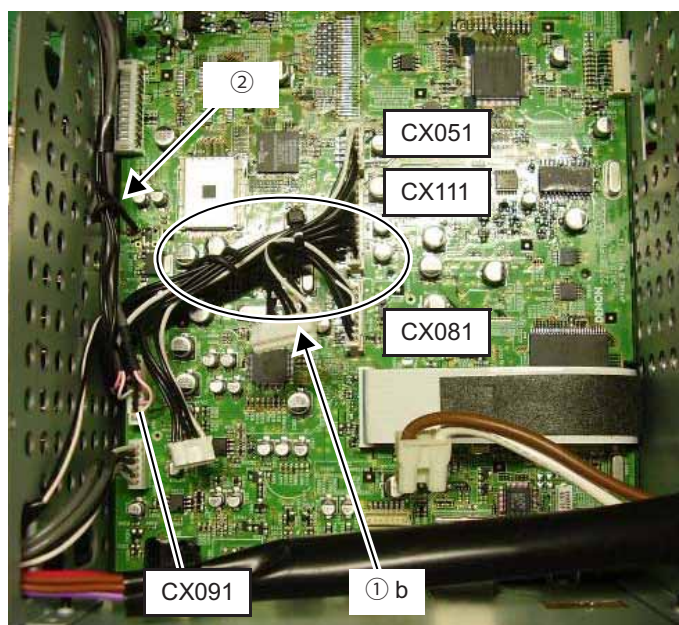

S-52DABEK

- ③ Fasten the CY064 6P ZH-ZH CON.CORD to the circuit board with a style pin.

- ③ CY064 6P ZH-ZH CON.CORD をスタイルピンで固定する。

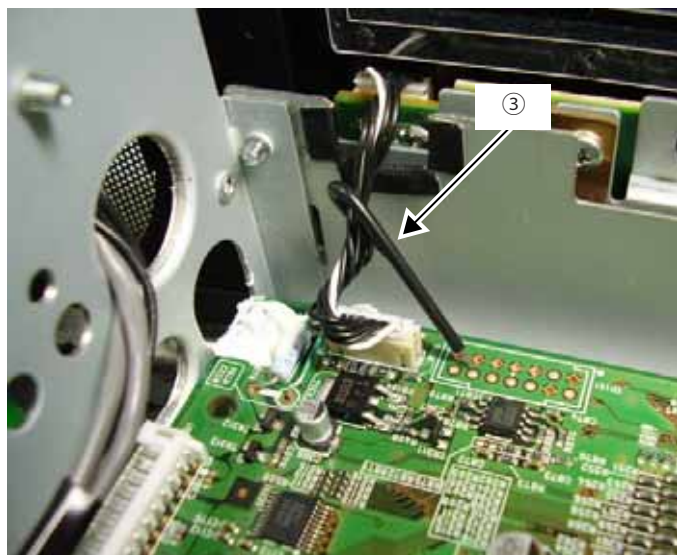

2. SIDE BRACKET(R)

- ④ Fasten the CY091 9P PH- PH SHIELD CORD on the H/P PORTBLE IN UNIT to the SIDE BRACKET (R) with a cord holder.

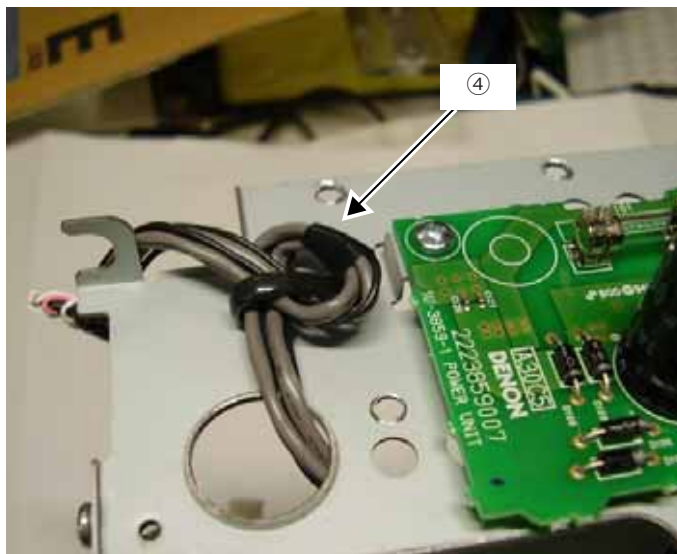

2. SIDE BRACKET(R) 部

- ④ H/P PORTBLE IN UNIT の CY091 9P PH- PH SHIELD CORD をコードホルダーで SIDE BRACKET (R) に固定する。

3. SIDE BRACKET(L)

- ⑤ Fasten the CY051 5P PH- PH CON. CORD on the USB TERM. UNIT to the SIDE BRACKET (L) with a cord holder.(S-52)
⑥ Fasten the CY051 5P PH- PH CON. CORD on the USB-TERM. UNIT to the SIDE BRACKET (L) with a clamp band.(S-52)

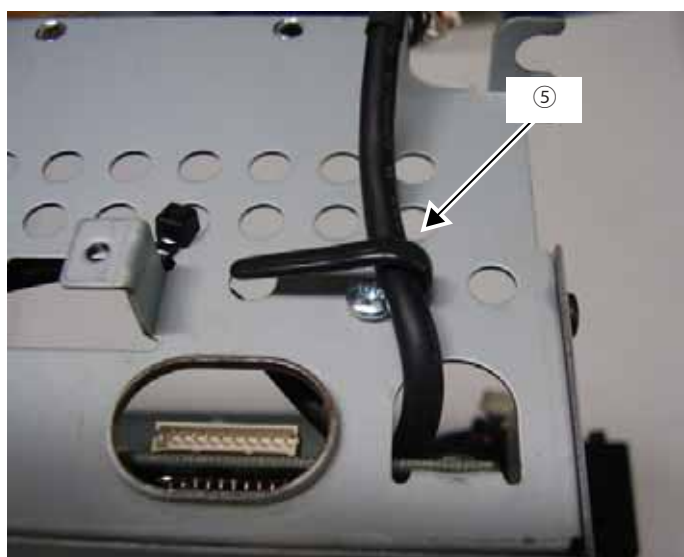

3. SIDE BRACKET(L) 部

- ⑤ USB TERM. UNIT の CY051 5P PH- PH CON. CORD をコードホルダーで SIDE BRACKET (L) に固定する。(S-52)
⑥ 同 5P PH- PH CON. CORD をクランプバンドで SIDE BRACKET (L) に固定する。(S-52)

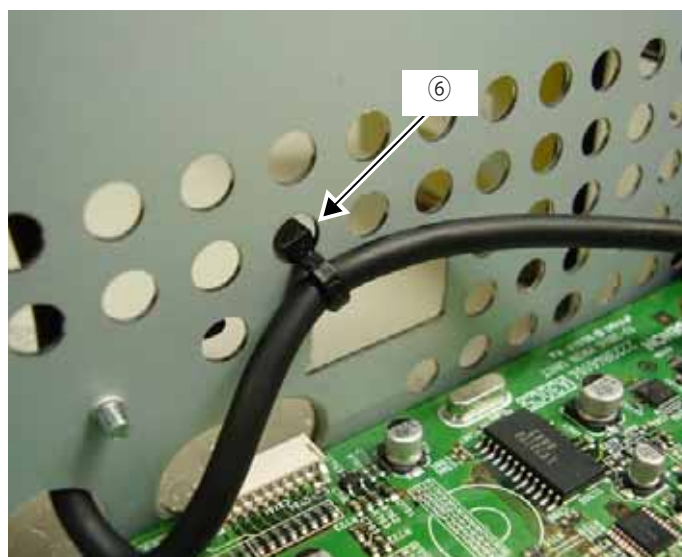

4. FERRITE CLAMP102010N

- ⑦ Coil and lock the primary side code of the power transformer with FERRITE CLAMP opened, then paste the EMIFILTER CUSHION to outer.
- ⑧ Fasten the FERRITE CLAMP to the EMIFILTER CUSHION with a clamp band .

4. FERRITE CLAMP102010N 部

- ⑦ FERRITE CLAMP を開いた状態でパワートランスの一次側コードを一回巻き付けてロックし、EMIFILTER CUSHION を外周に貼る。
- ⑧ FERRITE CLAMP を TRANS SHIELD にクランプバンドで固定する。

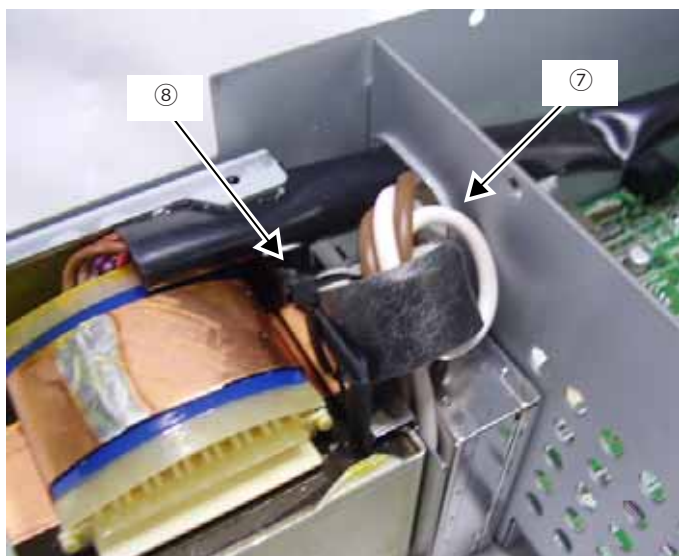

5. POWER UNIT & POWER AMP UNIT

- ⑨ Fasten the CY062 6P PH-PH SHIELD CORD and CX032 3P ZH-SAN CON.CORD and CY061 6P PH-PH CON.CORD and CX021 1P SAN EH CON.CORD and CX063 secondary side code of Power trans with a style pin.
- ⑩ Fasten the CY041 4P PH-PH CON. CORD with a style pin.

5. POWER UNIT & POWER AMP UNIT 部

- ⑨ CY062 6P PH-PH SHIELD CORD と CX032 3P ZH-SAN CON.CORD と CY061 6P PH-PH CON.CORD と CX021 1P SAN EH CON.CORD と CX063 パワートランス 2次側コード をスタイルピンで固定する。
- ⑩ CY041 4P PH-PH CON. CORD をスタイルピンで固定する。

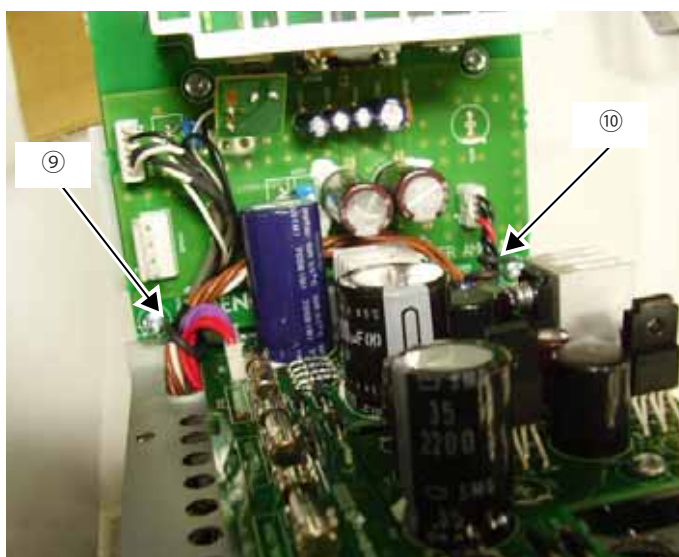

DISASSEMBLY

(Follow the procedure below in reverse order when reassembling.)

1. BOTTOM COVER & SPEAKER BLOCK

- (1) Remove the 2 screws 107 on the bottom side.
- (2) Detach the COVER PLATE in the direction of the arrow.
- (3) Disconnect the 4P VH CON.CORD from the [CY042] on the POWER AMP UNIT.

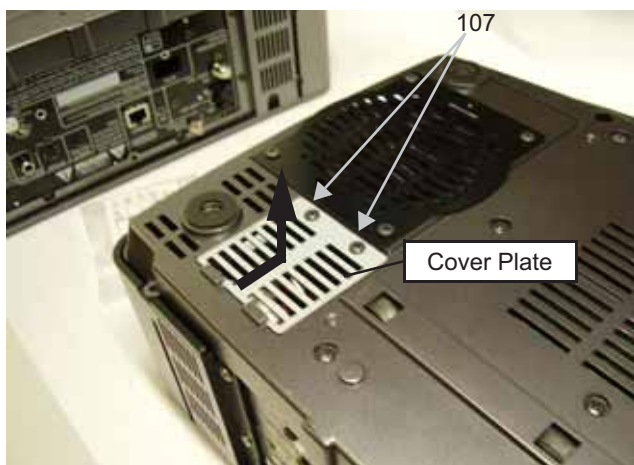

各部のはずしかた

(組み立てるときは、逆の順序でおこなってください。)

1. BOTTOM COVER & SPEAKER BLOCK

- (1) 底面側からの 107 のねじ 2 本をはずす。
- (2) COVER PLATE を矢印方向にずらしてはずす。
- (3) POWER AMP UNIT の [CY042] から 4P VH CON.CORD をはずす。



- (4) Remove the 8 screws 106 and 6 screws 111, the 2 screws 108 on the bottom side.
- (5) Detach the BOTTOM COVER & the SPEAKER BLOCK in the direction of the arrow.

- (4) 底面側からの 106 のねじ 8 本と 111 のねじ 6 本と 108 のねじ 2 本をはずす。
- (5) BOTTOM COVER & SPEAKER BLOCK を矢印方向にはずす。

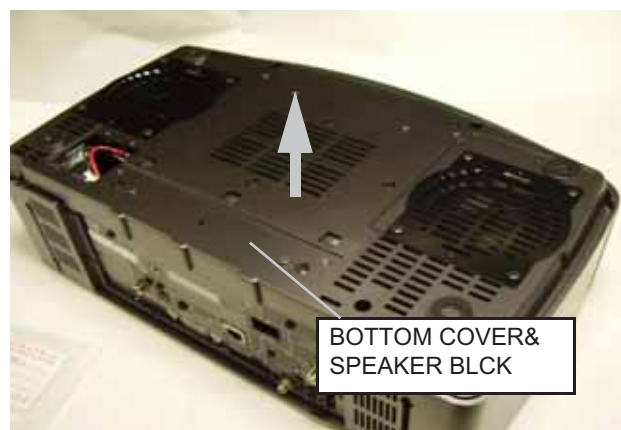
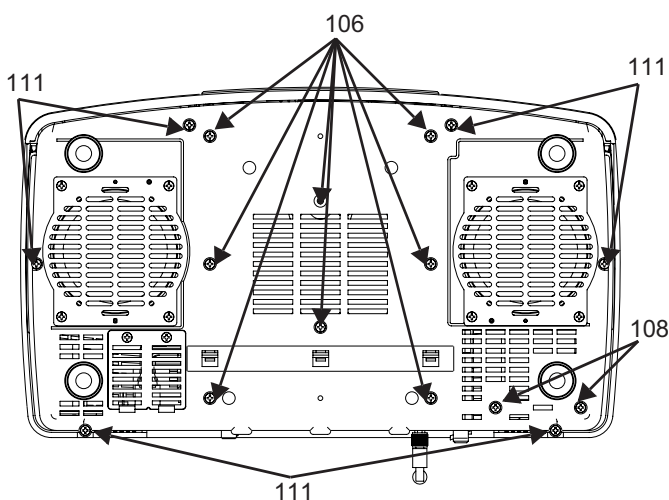

2. SPEAKER UNIT

- (1) Remove the 4 screws 109 fixing the SPEAKER BOX.
(Both left and right)

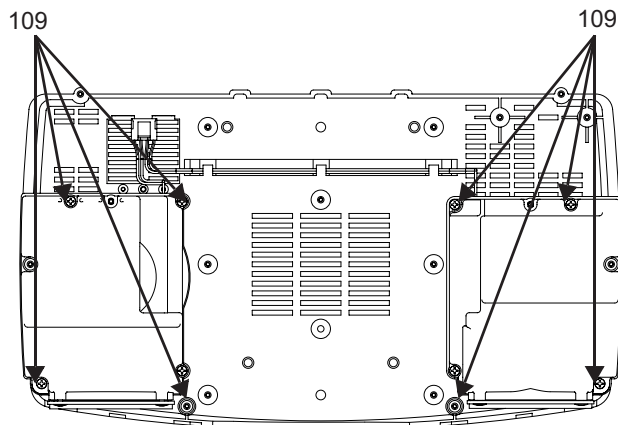

2. SPEAKER UNIT

- (1) SPEAKER BOX を固定している、109 のねじ 4 本をはずす。(左右同じ)

- (2) Remove the wire soldered to the SPEAKER terminal.
(Both left and right)
- (3) Remove the 4 screws 112 fixing the speaker, then detach the SPEAKER in the direction of the arrow.(Both left and right)

- (2) SPEAKER 端子に半田付けしてあるワイヤーをはずす。(左右同じ)
- (3) SPEAKER を固定している、112 のねじ 4 本をはずしてから矢印方向にはずす。(左右同じ)

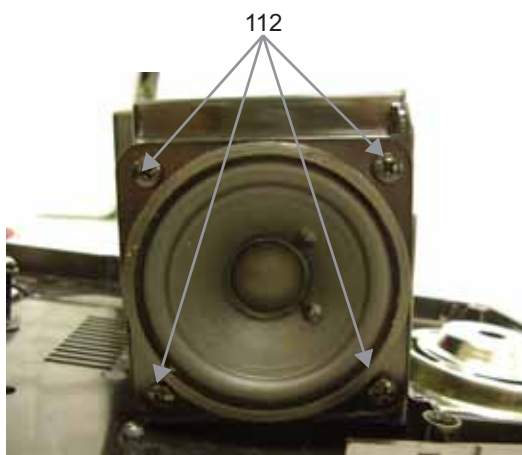

3A.CD MECHA BLOCK(S-52)

- (1) Remove the 7 screws 105 and the 1 screw 104.

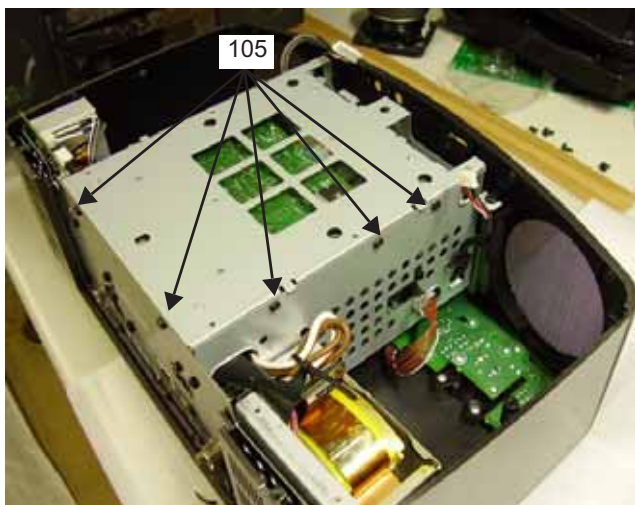

- (2) Remove the 4 screws 104.
 (3) Disconnect the 9P PH-PH SHIELD CORD from the [CY091] on the H/P PORTABLE IN UNIT.
 (4) Disconnect the 5P PH-PH CON.CORD from the [CY051] on the USB TERM. UNIT.

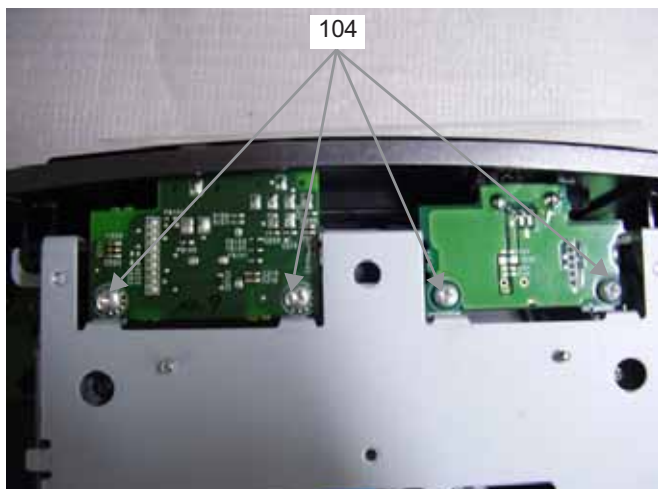

3A.CD MECHA BLOCK(S-52)

- (1) 105 のねじ 7 本と 104 のねじ 1 本をはずす。

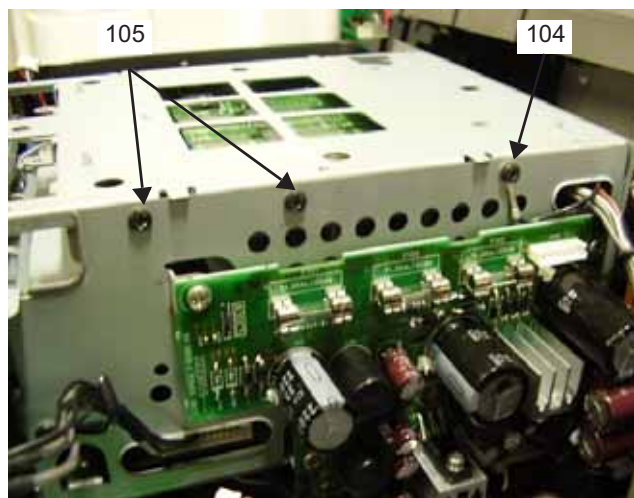

- (2) 104 のねじ 4 本をはずす。
 (3) H/P PORTABLE IN UNIT の [CY091] から 9P PH-PH SHIELD CORD をはずす。
 (4) USB TERM. UNIT の [CY051] から 5P PH-PH CON. CORD をはずす。

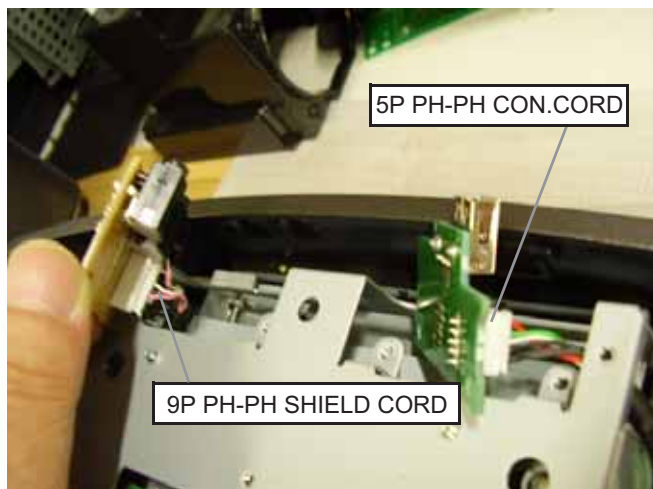

- (5) Disconnect the 9P/5P PH-PH CON.CORD in the direction of each the arrow.

- (5) 9P/5P PH-PH CON. CORD をそれぞれ矢印方向に引き出す。



- (6) Lift up the CD MECHA BLOCK as shown in the photo and disconnect the 30P FFC(1.0) from the the [CX151] on the MAIN UNIT.
- (7) Disconnect the 6P PH-PH CON.CORD from the the [CY061] on CD MECHA UNIT.

- (6) CD MECHA BLOCK を図のように持ち上げて MAIN UNIT の [CX151] から、30P FFC(1.0) をはずす
- (7) CD MECHA UNIT の [CY061] から、6P PH-PH CON.CORD をはずす。

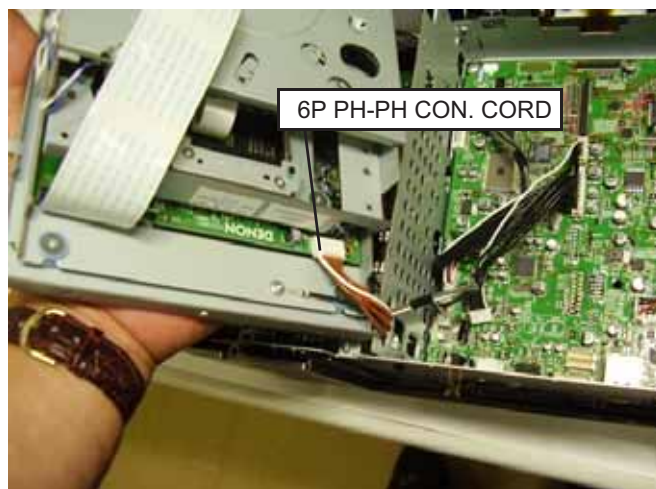

3B.MAIN CHASSIS(S-32)

- (1) Remove the 8 screws 105.

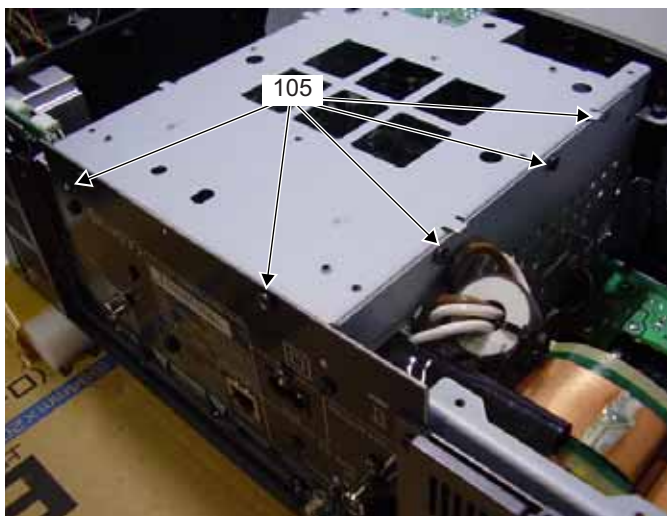

- (2) Remove the 2 screws 104.
 (3) Disconnect the 9P PH-PH SHIELD CORD from the [CY091] on the H/P PORTABLE IN UNIT.

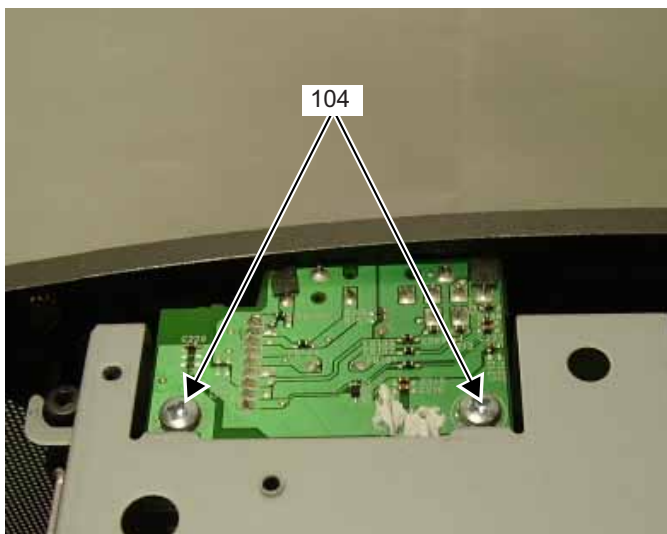

3B.MAIN CHASSIS(S-32)

- (1) 105 のねじ 8 本をはずす。

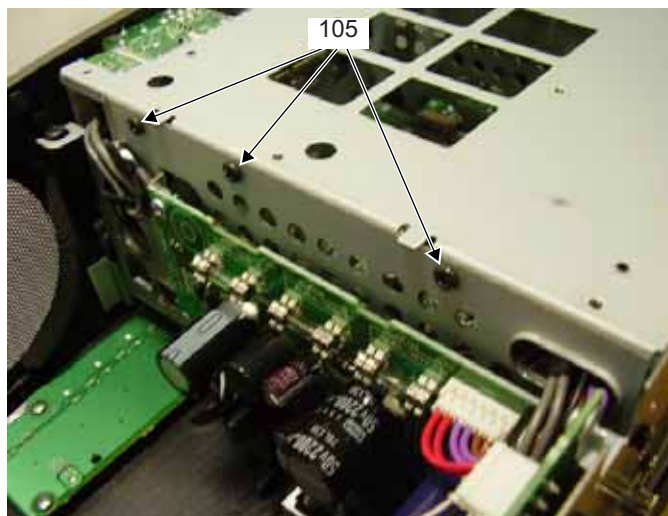

- (2) 104 のねじ 2 本をはずす。
 (3) H/P PORTABLE IN UNIT の [CY091] から 9P PH-PH SHIELD CORD をはずす。

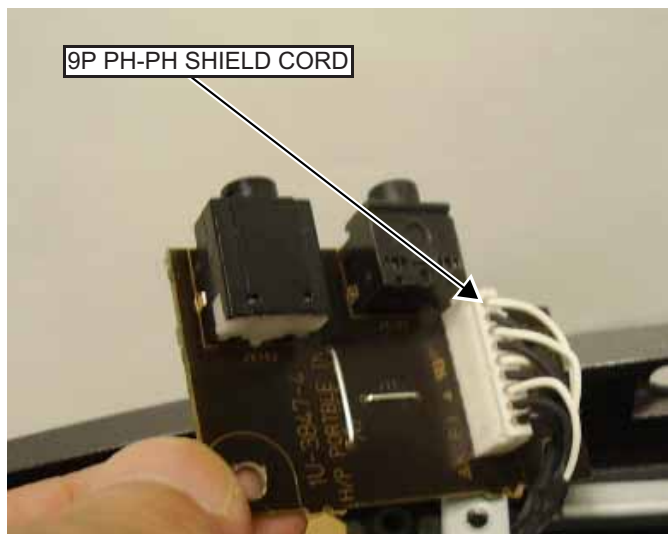

- (4) Disconnect the 9P PH-PH SHIELD CORD in the direction of the arrow A.
- (5) Disconnect the MAIN CHASSIS in the direction of the arrow B.

- (4) 9P PH-PH SHIELD CORD を矢印 A 方向に引き出す。
- (5) MAIN CHASSIS を矢印 B 方向にはずす。

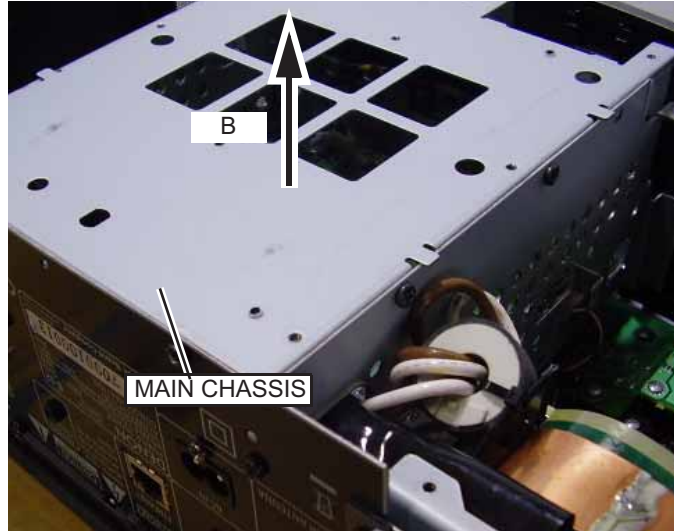
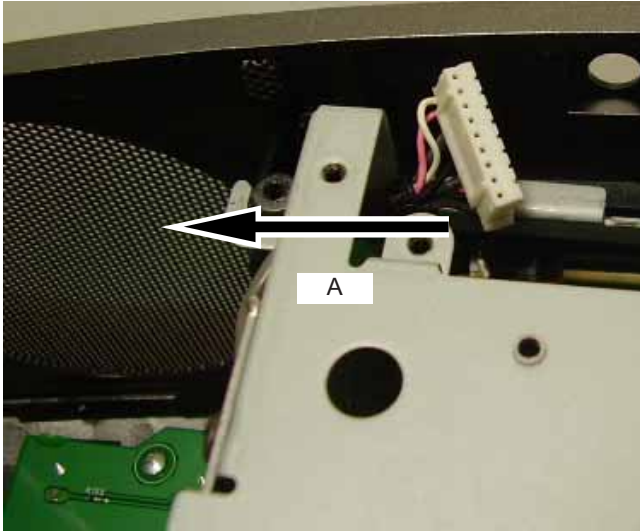

4. 1U-3851 CD ROM UNIT(S-52)

- (1) Remove each 2 screws D and E, then detach the MAIN CHASSIS and the MECHA BRACKET in the direction of the arrow.

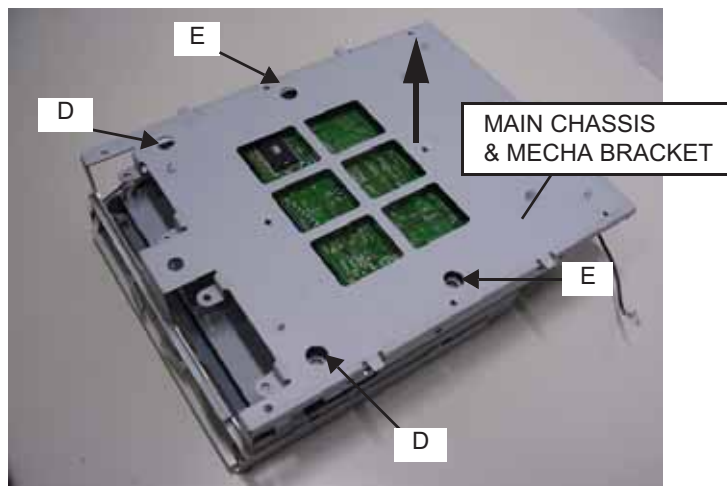

4. 1U-3851 CD ROM UNIT(S-52)

- (1) Dのねじ2本とEのねじ2本をはずしてから、MAIN CHASSISとMECHA BRACKETを矢印方向にはずす。

- (2) Move the Pick Up to the rear side and solder the short-circuit, then disconnect the FFC.

- (2) ピックアップを後方に移動し、半田付けショートを行ってから、FFCをはずす。

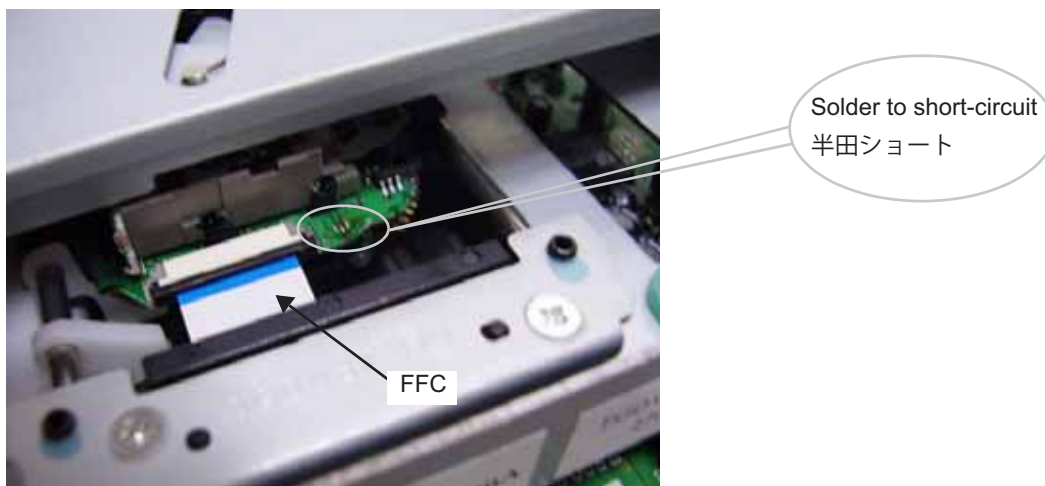

(3) Disconnect the 2P, 3P, 4P Wire and the FFC, then remove the 2 screws E.

(3) 2P、3P、4P ワイヤー及び FFC をはずし、E のねじ 2 本をはずす。

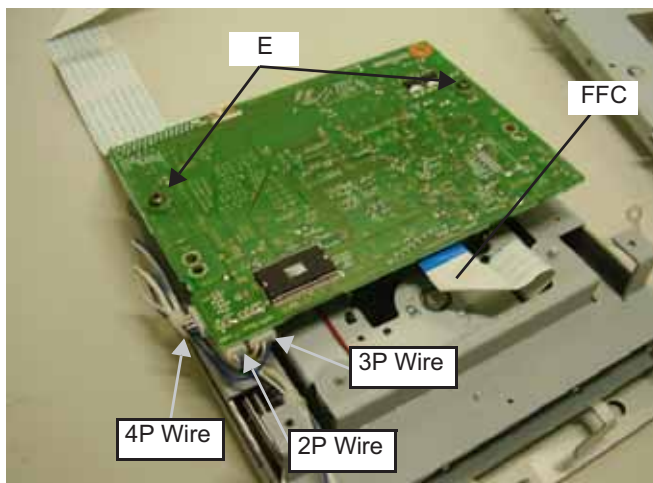

(4) Stand the CD ROM UNIT and disconnect the FFC.

(4) CD ROM UNIT を起こし、FFC をはずす。

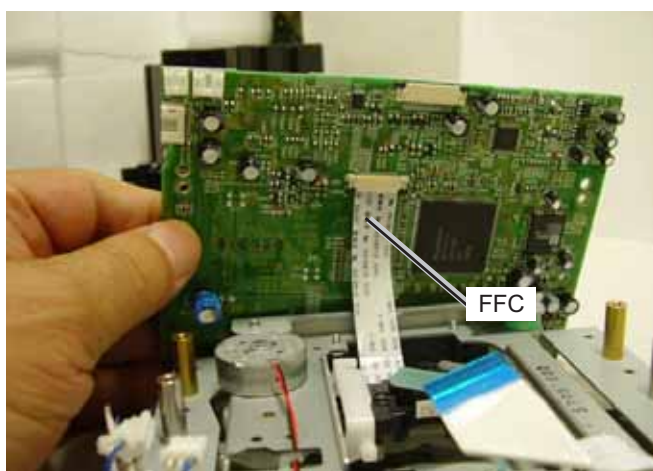

5. MAIN BLOCK

- (1) Remove the 5 screws 106 and the 5 screws 108 on the rear.

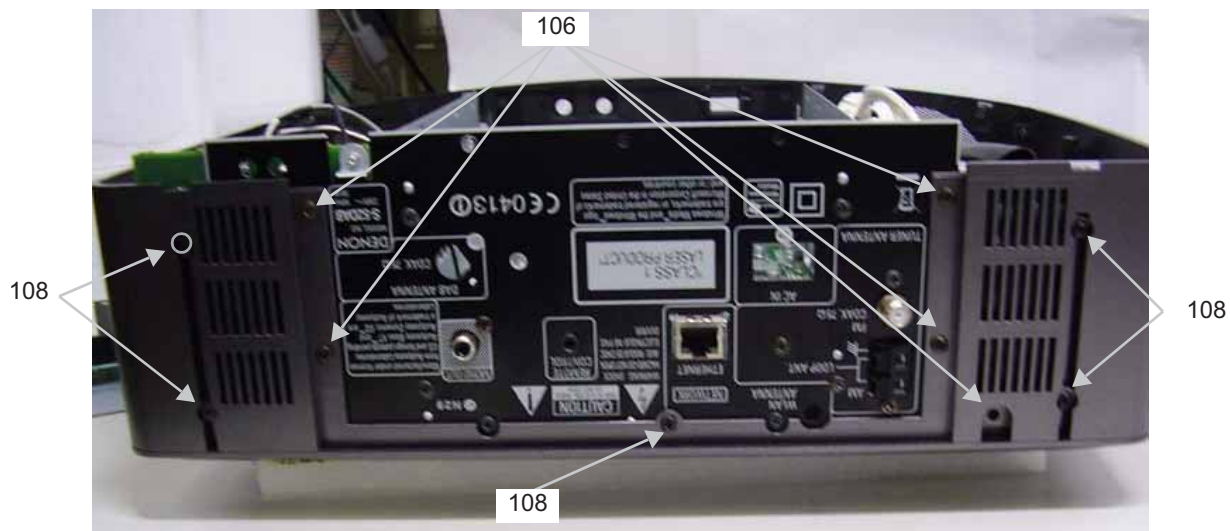

5. MAIN BLOCK

- (1) 後面側からの 106 のねじ 5 本と 108 ねじ 5 本をはずす。

- (2) Disconnect the 10P ZH-JB CON.CORD from the [CX101] on the MAIN UNIT.
 (3) Disconnect the 13P PH-PH SHIELD CORD from the [CX131] on the MAIN UNIT.

- (2) MAIN UNITの [CX101] から 10P ZH-JB CON.CORD をはずす。
 (3) MAIN UNITの [CX131] から 13P PH-PH SHIELD CORD をはずす。

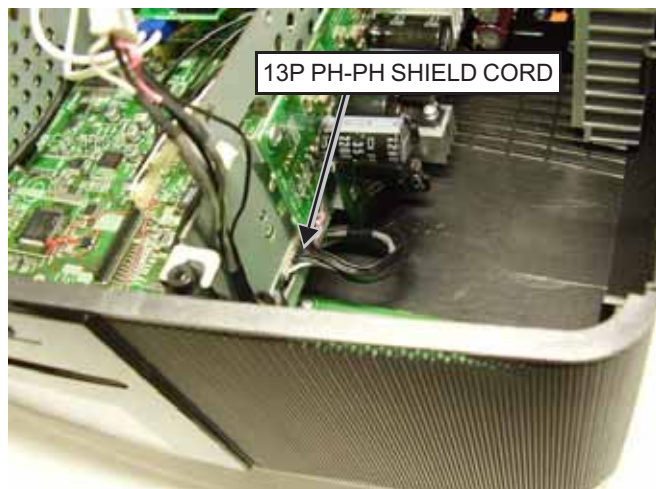
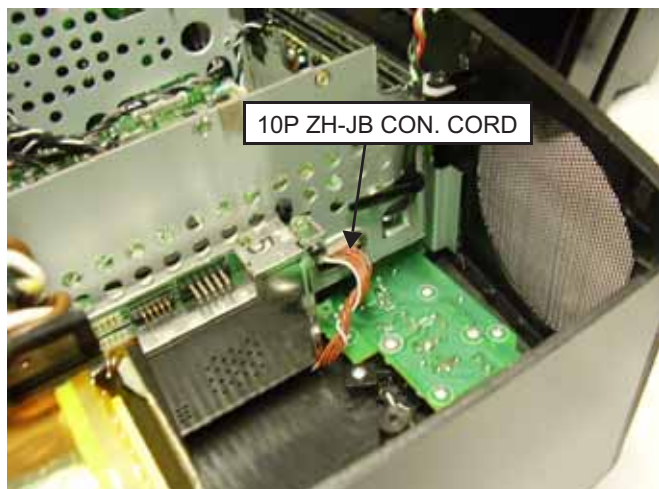

- (4) Disconnect the 16P FPC from the [CX161] on the MAIN UNIT.
- (5) Disconnect the 6P ZH-ZH CON.CORD from the [CX064] the MAIN UNIT.

- (4) MAIN UNITの[CX161]から16P FPCをはずす。
- (5) MAIN UNITの[CX064]から6P ZH-ZH CON.CORDをはずす。

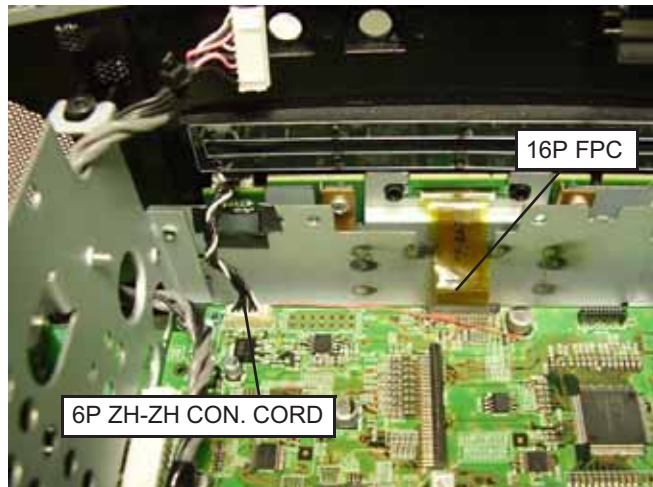

- (6) Detach the MAIN BLOCK in the direction of the arrow.

- (6) MAIN BLOCKを矢印方向にはずす。



6A. 1U-3854 STANDBY TRANS UNIT (for JP/E3/E2)

- (1) Remove the 1 screw 113 and the 1 screw 105 on the rear.

6A. 1U-3854 STANDBY TRANS UNIT (JP/E3/E2)

- (1) 113 のねじ 1 本と 105 のねじ 1 本をはずす。

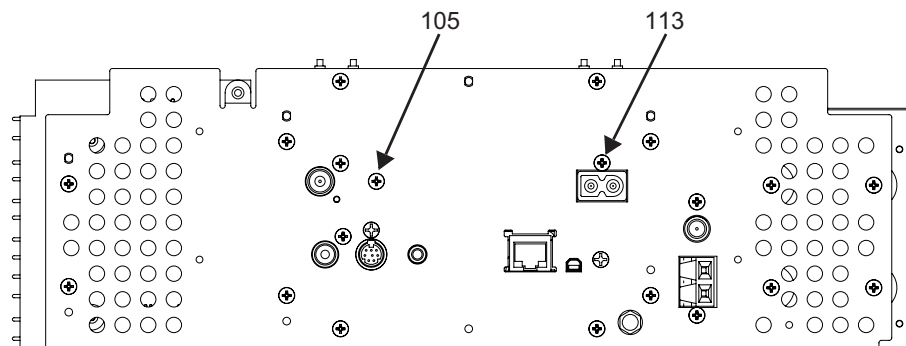

- (2) Disconnect the 5P PH-PH CON.CORD from the [CX051] on the STANDBY TRANS UNIT.
- (3) Disconnect the 2P Wire from the [CX121] on the STANDBY TRANS UNIT.
- (4) Detach the STANDBY TRANS UNIT in the direction of the arrow.

- (2) STANDBY TRANS UNIT の [CX051] から 5P PH-PH CON. CORD をはずす。
- (3) STANDBY TRANS UNIT の [CX121] から 2P ワイヤーをはずす。
- (4) STANDBY TRANS UNIT を矢印方向にはずす。

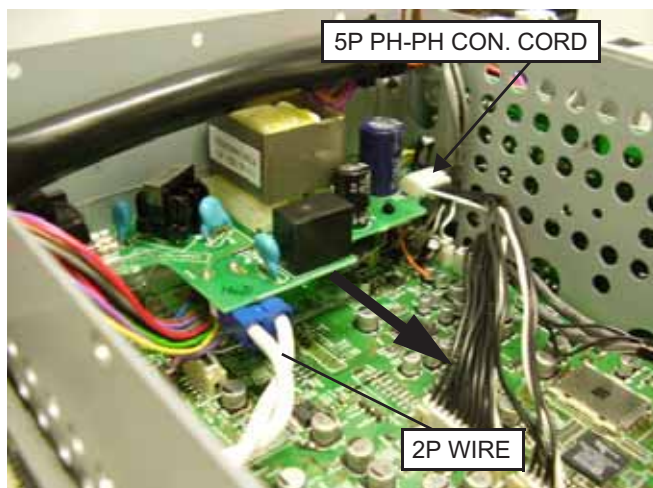

6B. 1U-3854 STANDBY TRANS UNIT(for EK)

- (1) Disconnect the 8P PH-PH SHIELD CORD from the [CY081] on 1U-3847-2.
- (2) Remove the 2 side screws 117, then detach the DAB SUB ASS'Y.

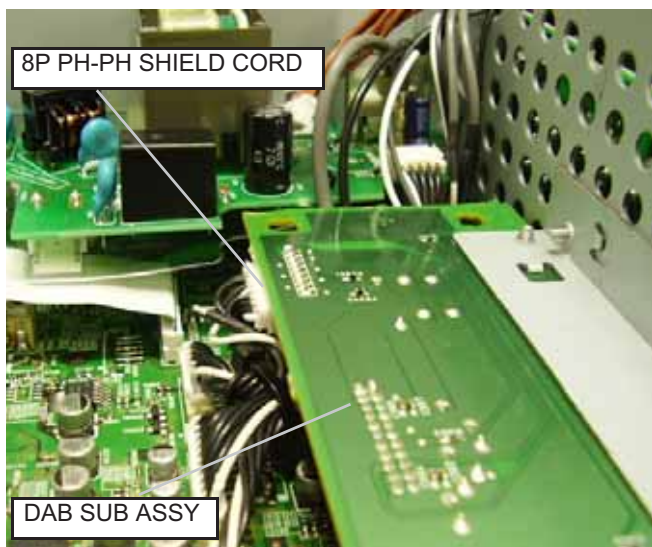

- (3) Remove the 2 screws 113 and the 1 screw 105 on the rear.
- (4) Disconnect the 5P PH-PH CON.CORD from the [CX051] on the STANDBY TRANS UNIT.
- (5) Disconnect the 2P Wire from the [CX121] on the STANDBY TRANS UNIT.
- (6) Detach the STANDBY TRANS UNIT in the direction of the arrow.

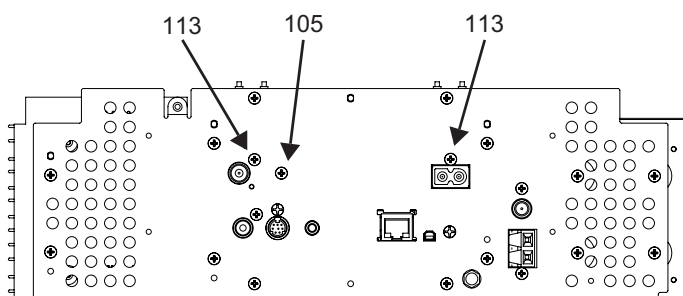

6B. 1U-3854 STANDBY TRANS UNIT (EK)

- (1) 1U-3847-2 の [CY081] から 8P PH-PH SHIELD CORD をはずす。
- (2) 側面の 117 のねじ 2 本をはずし、DAB SUB ASS'Y をはずす。



- (3) 後面側から、113 のねじ 2 本と 105 のねじ 1 本をはずす。
- (4) STANDBY TRANS UNIT の [CX051] から 5P PH-PH CON. CORD をはずす。
- (5) STANDBY TRANS UNIT の [CX121] から 2P ワイヤーをはずす。
- (6) STANDBY TRANS UNIT を矢印方向にはずす。

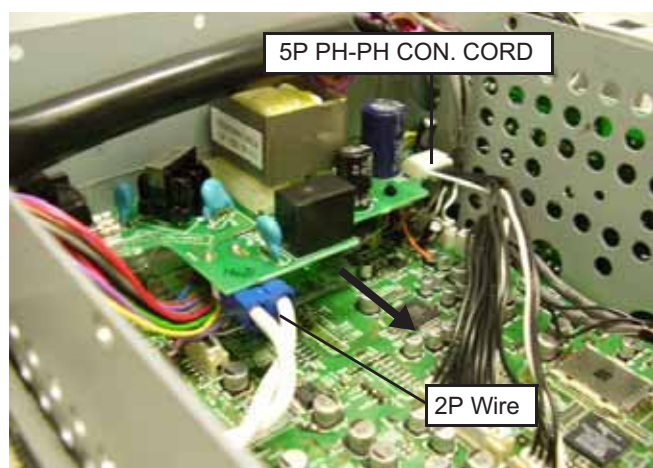

7. POWER TRANS

- (1) Remove the 4 screws 105 on the rear.



7. POWER TRANS

- (1) 後面側から、105 のねじ 4 本をはずす。

8. 1U-3847-1 POWER AMP UNIT

- (1) Disconnect the 6P PH-PH SHIELD CORD from the [CY062] on the POWER AMP UNIT.
- (2) Disconnect the 1P SIN EH CONN CORD from the [CY021] on the POWER AMP UNIT.
- (3) Disconnect the 4P PH-PH CON.CORD from the [CY041] on the POWER AMP UNIT.
- (4) Disconnect the 3P ZH-SAN CON.CORD from the the [CX303] on the MAIN UNIT and pull out in the direction of the arrow.

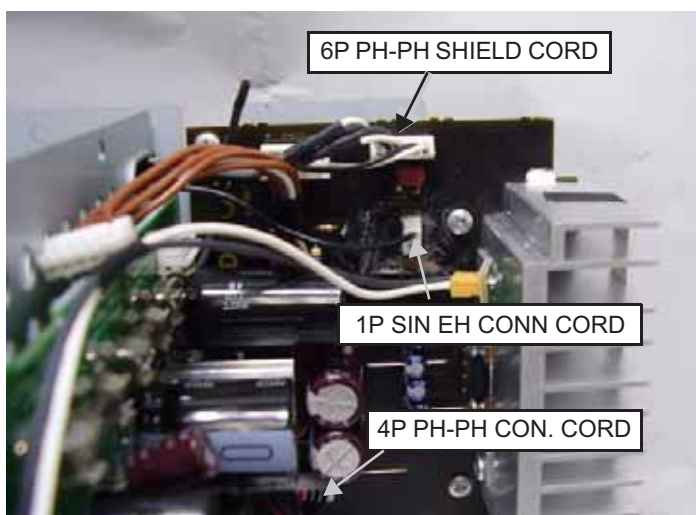

8. 1U-3847-1 POWER AMP UNIT

- (1) POWER AMP UNIT の [CY062] から 6P PH-PH SHIELD CORD をはずす。
- (2) POWER AMP UNIT の [CX021] から 1P SIN EH CONN CORD をはずす。
- (3) POWER AMP UNIT の [CY041] から 4P PH-PH CON.CORD をはずす。
- (4) MAIN UNIT の [CX303] から 3P ZH-SAN CON.CORD をはずし、矢印方向に引き抜く。



- (5) Remove the 2 inside screws 104 and the 2 rear screws 105.

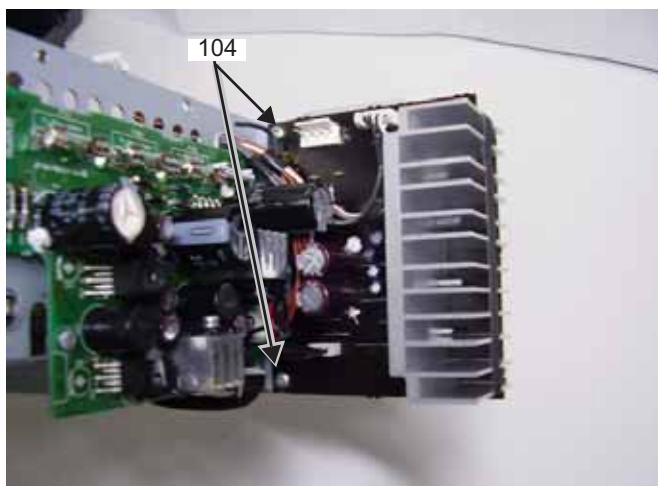

- (5) 内側の 104 のねじ 2 本と、後面側から 105 のねじ 2 本をはずす。



9. 1U-3859-1 POWER UNIT

- (1) Disconnect the 11P PH-PH CON.CORD from the [CY111] on the POWER UNIT.
- (2) Disconnect the 6P PH-PH CON.CORD from the [CY061] on the POWER UNIT.
- (3) Remove the 4 screws 104.

9. 1U-3859-1 POWER UNIT

- (1) POWER UNIT の [CY111] から 11P PH-PH CON.CORD をはずす。
- (2) POWER UNIT の [CY061] から 6P PH-PH CON.CORD をはずす。
- (3) 104 のねじ 4 本をはずす。

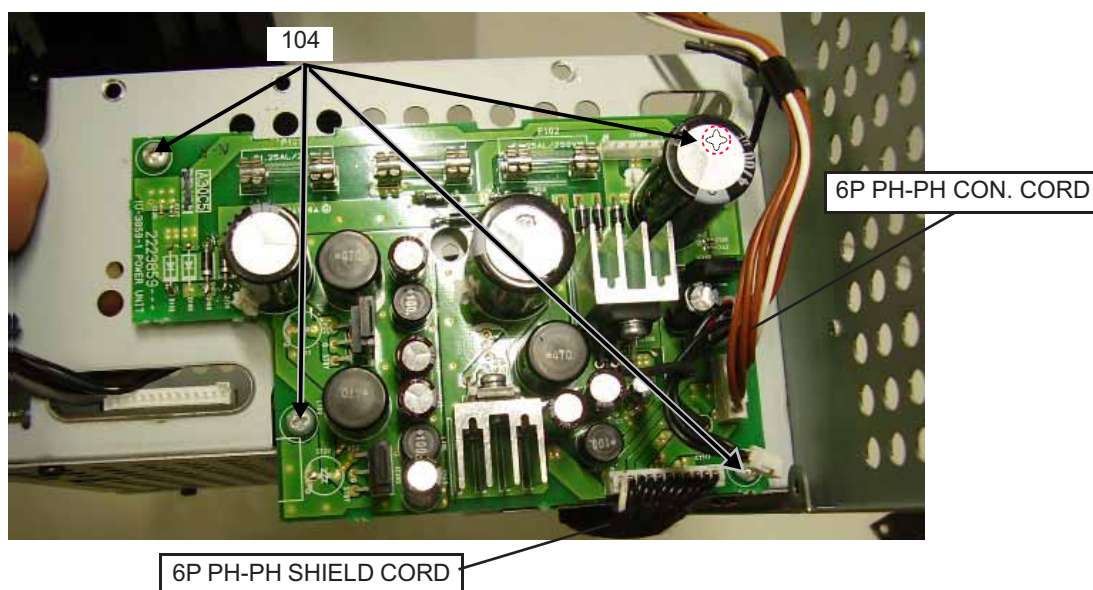

10. 1U-3846 MAIN UNIT

- (1) Remove the 2 screws 104 where the code holder outside of the side bracket is fixed.

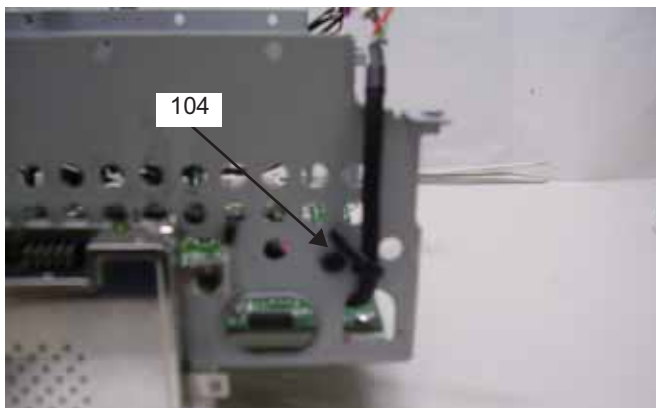

- (2) Cut off the 1 WIRE CLAMPER and remove.(S-52 only)
- (3) Disconnect the 16P CON.CORD from the [CX161] on the MAIN UNIT.(S-52E3 only)
- (4) Disconnect the 15P FFC CABLE from the [CX151] on the MAIN UNIT.(S-52JP/E2/EK,S-32E2/E3)
- (5) Disconnect the 6P PH-PH CON.CORD from the [CX062] on the MAIN UNIT.
- (6) Disconnect the 9P PH-PH CON.CORD from the [CX091] on the MAIN UNIT.
- (7) Disconnect the 3P ZH-SAN CON.CORD from the [CX303] on the MAIN UNIT.
- (8) Disconnect the 5P PH-PH CON.CORD from the [CX051] on the MAIN UNIT.
- (9) Disconnect the 5P PH-PH CON.CORD from the [CX054] on the MAIN UNIT.(S-52 only)
- (10) Disconnect 8P PH-PH CON.CORD from the [CX081] on the MAIN UNIT.(EK only)
- (11) Disconnect 11P PH-PH CON.CORD from the [CX111] on the MAIN UNIT.

10. 1U-3846 MAIN UNIT

- (1) サイドブラケット外側のコードホルダーを固定している 104 のねじ 2 本をはずす。

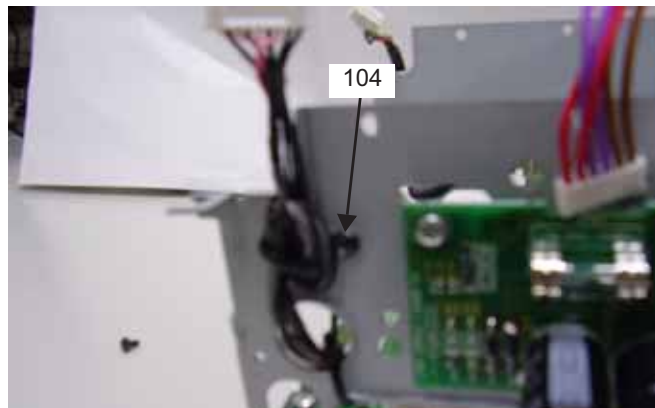

- (2) WIRE CLAMPER 1 箇所をカットし、取り除く。(S-52 のみ)
- (3) MAIN UNIT の [CX161] から 16P CON.CORD をはずす。(S-52E3 のみ)
- (4) MAIN UNIT の [CX151] から 15P FFC CABLE をはずす。(S-52JP/E2/EK,S-32E2/E3)
- (5) MAIN UNIT の [CX062] から 6P PH-PH CON.CORD をはずす。
- (6) MAIN UNIT の [CX091] から 9P PH-PH CON.CORD をはずす。
- (7) MAIN UNIT の [CX303] から 3P ZH-SAN CON.CORD をはずす。
- (8) MAIN UNIT の [CX051] から 5P PH-PH CON.CORD をはずす。
- (9) MAIN UNIT の [CX054] から 5P PH-PH CON.CORD をはずす。(S-52 のみ)
- (10) MAIN UNIT の [CX081] から 8P PH-PH CON.CORD をはずす。(EK のみ)
- (11) MAIN UNIT の [CX111] から 11P PH-PH CON.CORD をはずす。

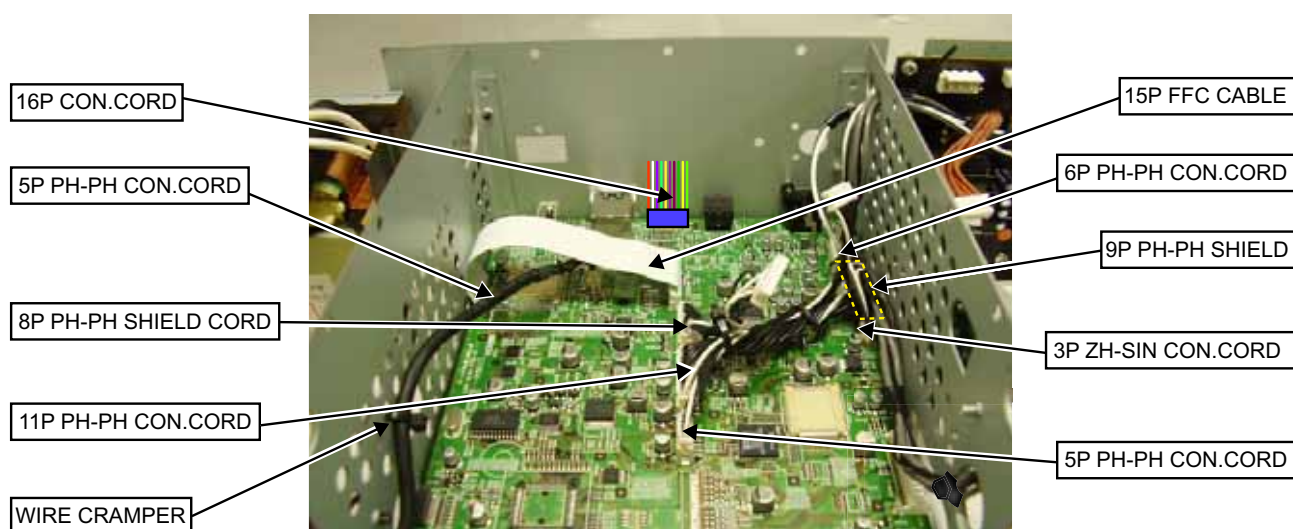

(12) Disconnect the 1P SAN EH CON.CORD from CX021 on the Power Amp Unit, then pull out in the direction of the arrow.

(12) POWER AMP UNIT の [CX021] から 1P SAN EH CON. CORD をはずし、矢印方向に引き抜く。

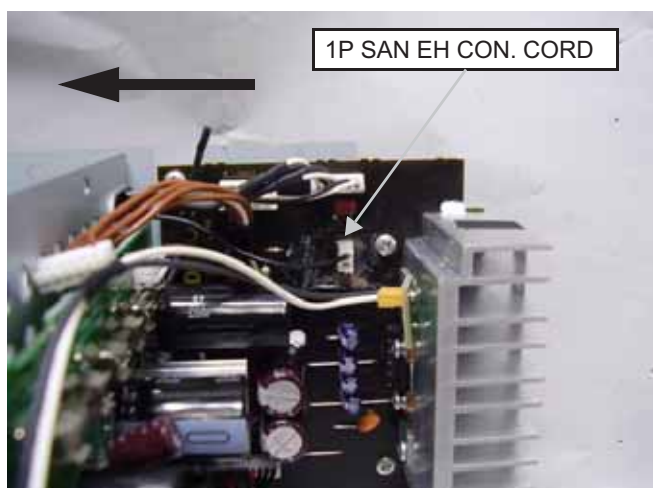

(13A) Remove the 4 screws 105 and the 1 screw 113. (E3 only)

(13A) 105 のねじ 4 本と 113 のねじ 1 本をはずす。(E3のみ)

(13B) Remove the 3 screws 105 and the 1 screw 113. (JP/E2/EK only)

(13B) 105 のねじ 3 本と 113 のねじ 1 本をはずす。(JP/E2/EKのみ)

(14) Remove the WASHER 114 and the NUT 115.

(14) 114 のワッシャーと 115 のナットをはずす。

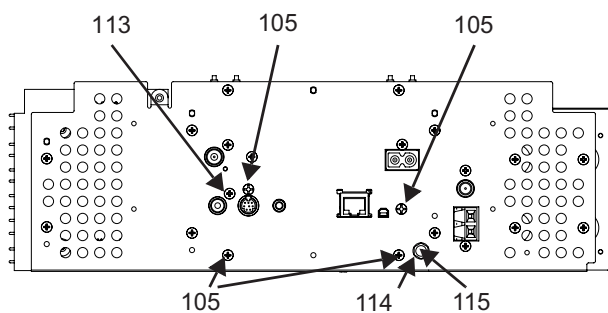

E3

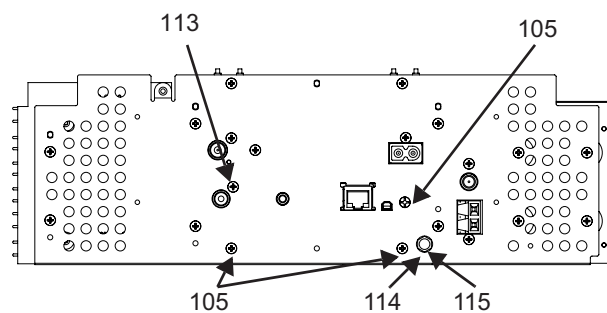

JP/E2/EK

- (15) Remove the 6 screws 105 and the 2 screws 104, the 2 washers 118.
- (16) Disconnect the 15P FFC CABLE from the AM FM TUNER.(S-52JP/E2/EK,S-32E2/E3)
- (17) Disconnect the 9P PH-PH SHIELD CORD from the [CX063] on the POWER UNIT.
- (18) Detach the TOP BRACKET in the direction of the arrow.

- (15) 105 のねじ 6 本と、104 のねじ 2 本、118 の 3W2 枚をはずす。
- (16) AM FM TUNER から、15P FFC CABLE をはずす。(S-52JP/E2/EK、S-32E2/E3)
- (17) POWER UNIT の [CX063] から 9P PH-PH SHIELD CORD をはずす。
- (18) TOP BRACKET を矢印方向へはずす。

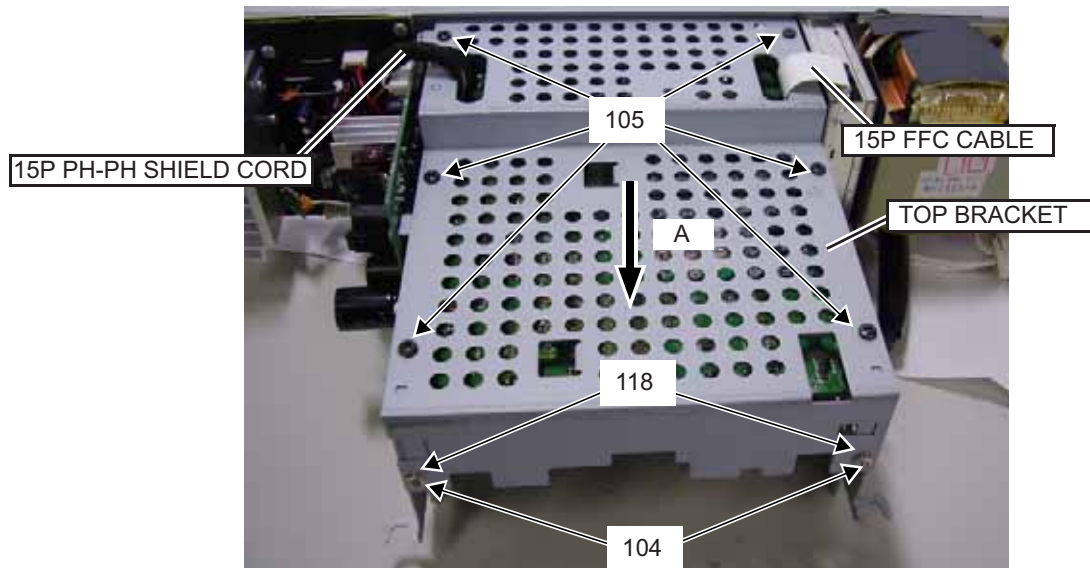

- (19) Remove the 3 screws 104.
- (20) Lift up the front of MAIN UNIT and detach it in the direction of the arrow.

- (19) 104 のねじ 3 本をはずす。
- (20) MAIN UNIT の前側を持ち上げ、矢印方向に引き抜く。

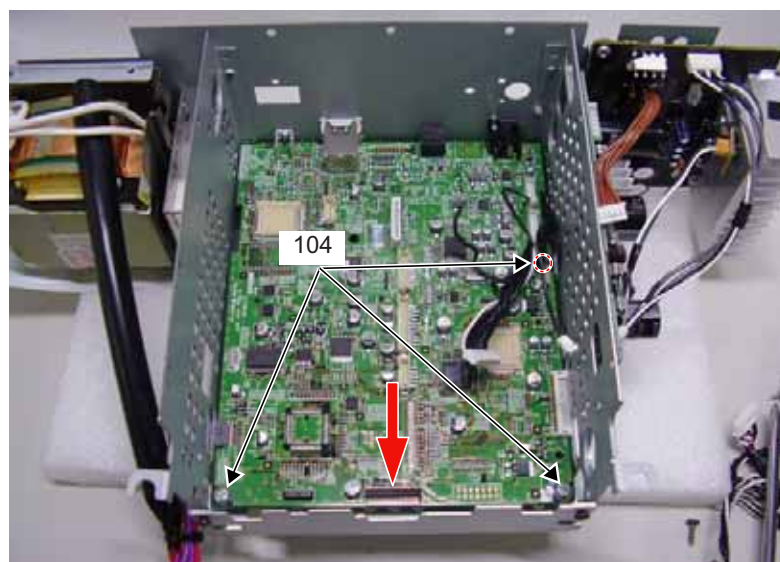

11.ROTARY KNOB

- (1) The SNAP FIT is bent from the back of the CABINET in the direction of the arrow ① .
- (2) The ROTARY KNOB RING is rotated in the direction of the arrow ② and detach.
- (3) Detach the ROTARY KNOB in the direction of the arrow ③ .

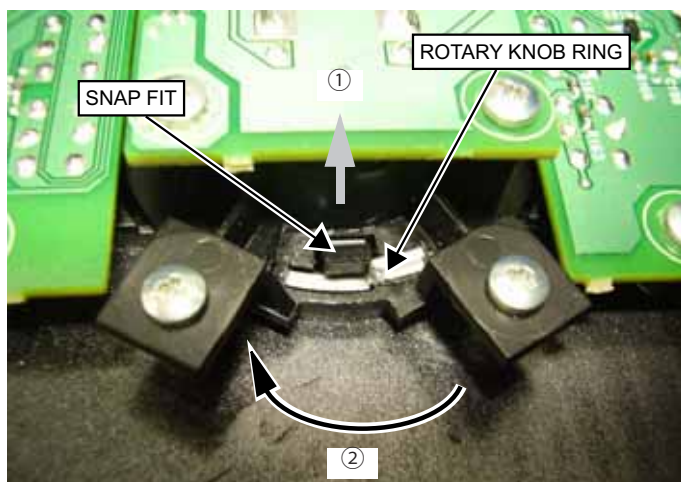

11.ROTARY KNOB

- (1) CABINET 裏側面より、SNAP FIT を矢印①方向にたわませる。
- (2) ROTARY KNOB RING を矢印②方向に回転させて、表面側より抜き取る。
- (3) ROTARY KNOB を矢印③方向に抜き取る。

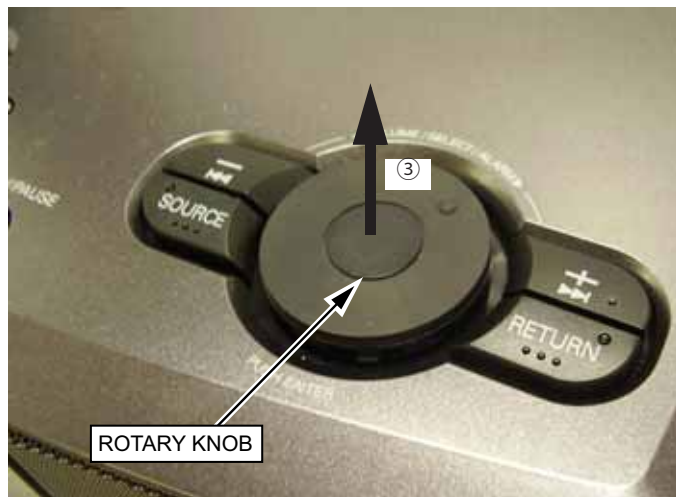

DIAGNOSTICS OF OPTICAL PICKUP AND REPLACING TRAVERSE UNIT

Make failure diagnostics of the Optical Pickup as follows.
 If the laser drive current (Iop) becomes more than 1.5 times of the initial value, the Optical Pickup should be replaced.
 The laser drive current initial value is checked by "Iop checked Method" of next page.
 In case of replacing the Pickup, change the whole part of the Traverse Unit.
 No mechanical adjustment is necessary after the replacement.

光ピックアップの故障診断とトラバースユニットの交換

次の順序で故障診断を行ってください。
 レーザー駆動電流 Iop 値が初期値の 1.5 倍以上になっている場合は光ピックアップ交換の目安となります。
 レーザー駆動電流初期値は、次ページ "Iop 値の確認方法" で確認できます。
 ピックアップ交換の場合は、トラバースユニット単位での交換となります。メカの調整は不要です。

レーザー駆動電流初期値：

Laser drive current initial value:

| Display (The display part of 13 digits) | | | | | | | | | | | | |
|---|---|---|---|---|---|---|---|---|----|----|----|----|
| 1 | 2 | 3 | 4 | 5 | 6 | 7 | 8 | 9 | 10 | 11 | 12 | 13 |
| T | 2 | 1 | — | m | m | m | m | — | n | n | n | n |

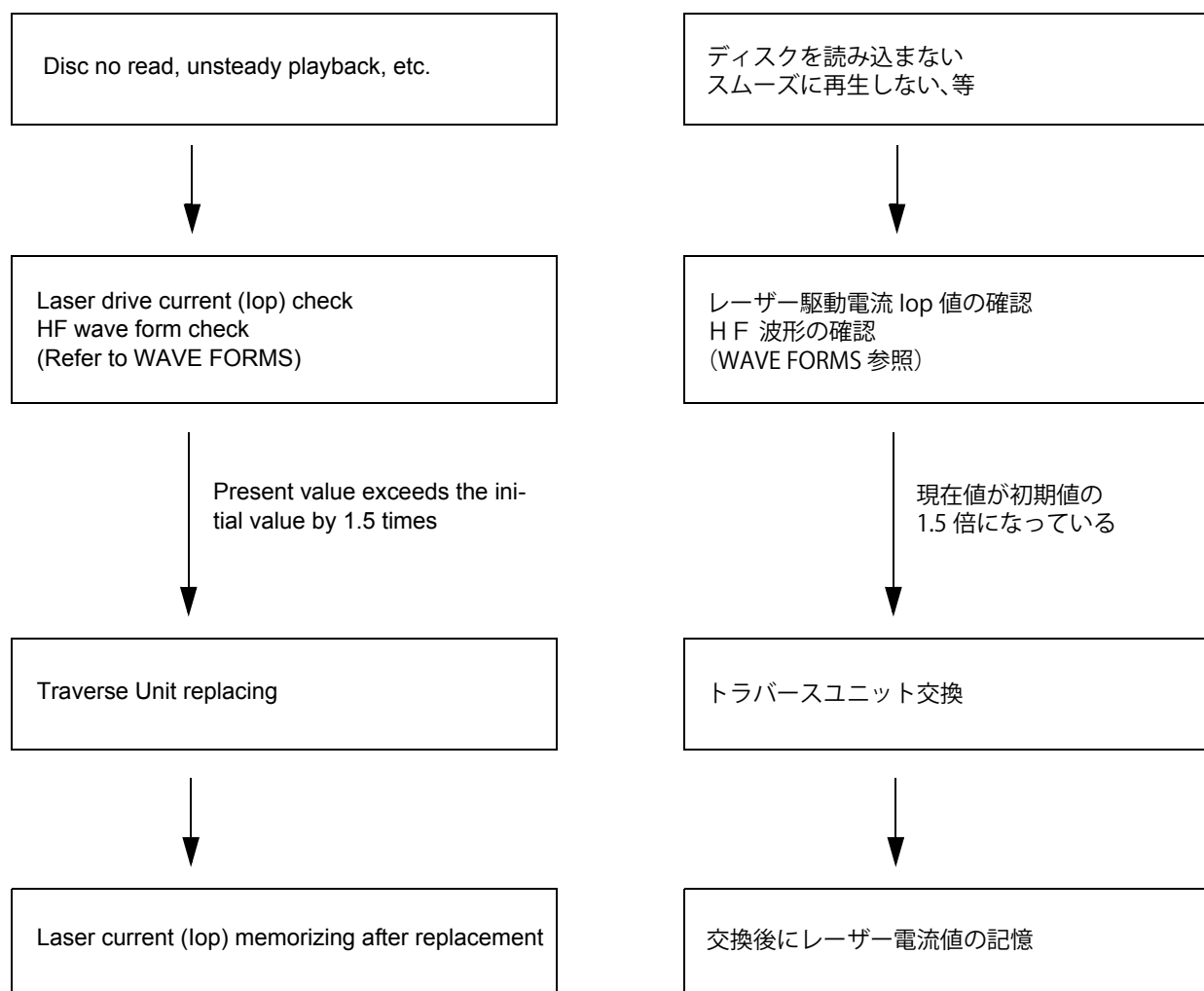

1. lop checked Method

Select the laser ON/OFF (CD) mode of the test mode, and check the lop value of CD laser.
(See page 32 for test mode.)

| Display (The display part of 13 digits) | | | | | | | | | | | | |
|---|---|---|---|---|---|---|---|---|----|----|----|----|
| 1 | 2 | 3 | 4 | 5 | 6 | 7 | 8 | 9 | 10 | 11 | 12 | 13 |
| T | 2 | | L | a | s | e | r | O | n | O | f | f |

1.1. CD Laser current check

- Press the **◀◀** or **▶▶** button to display the laser current value, and then select T21.
- Check the current value of lop (nnnn).

| Display (The display part of 13 digits) | | | | | | | | | | | | |
|---|---|---|---|---|---|---|---|---|----|----|----|----|
| 1 | 2 | 3 | 4 | 5 | 6 | 7 | 8 | 9 | 10 | 11 | 12 | 13 |
| T | 2 | 1 | — | m | m | m | m | — | n | n | n | n |

(— : Off, CD laser, Initial value: mm.mm [mA],
Current value: nn.nn [mA])

2. Note for Handling the Laser Pick-Up

The protection for the damage of laser diode.
If you want to change the optical device unit from any other units, you must keep the following.

- It should be done at the desk already took measures the static electricity in care of removing the OPU's (Optical device unit) connector cable.
- Workers should be put on the "Earth Band".
- It should be done to add the solder to the short land to prevent the broken Laser diode before removing the 24P FFC cable.
- Don't touch OPU's connector parts carelessly.

3. Replacement of the Laser Pick-up (Traverse Unit)

Check the lop (Laser drive current)
If the present lop (current) value exceeds +150% of the initial value, replace the Traverse unit (Laser Pick-up) with a new one.

1. lop 値の確認方法

レーザー駆動電流を確認する場合は、テストモードのレーザー ON/OFF (CD) モードを選択して、CD レーザーの lop 値を確認します。
(詳細は 32 ページ、テストモード参照)

| 表示 (13 桁の表示部) | | | | | | | | | | | | |
|---------------|---|---|---|---|---|---|---|---|----|----|----|----|
| 1 | 2 | 3 | 4 | 5 | 6 | 7 | 8 | 9 | 10 | 11 | 12 | 13 |
| T | 2 | | L | a | s | e | r | O | n | O | f | f |

1.1. CD レーザー電流確認

- レーザー電流値を表示する場合は、**◀◀** ボタンまたは **▶▶** ボタンを押し、T21 を選択します。
- 現在の lop 値 (nnnn) を確認します。

| 表示 (13 桁の表示部) | | | | | | | | | | | | |
|---------------|---|---|---|---|---|---|---|---|----|----|----|----|
| 1 | 2 | 3 | 4 | 5 | 6 | 7 | 8 | 9 | 10 | 11 | 12 | 13 |
| T | 2 | 1 | — | m | m | m | m | — | n | n | n | n |

(— : 消灯、CD レーザー、初期値: mm.mm[mA],
現在値: nn.nn[mA])

2. レーザーピックアップの取扱注意

レーザーダイオードの破壊防止。
光素子ユニットを交換するときは、以下を遵守してください。

- 光素子ユニットの接続ケーブルをはずすときは、静電対策を行ったデスク上で作業してください。
- 作業者は、リストストラップを使用してください。
- レーザーダイオードの破壊防止のため、24P FFC ケーブルをはずす前にランドを半田付けショートしてください。
- 光素子ユニットのコネクタ部に触れないでください。

3. レーザーピックアップ (トラバースユニット) の交換

lop (レーザー駆動電流) をチェックします。
現在の lop 値が初期値の 150% を越えている場合、トラバースユニット (レーザーピックアップ) を交換してください。

4. Rewriting the default value of the laser current

To rewrite the default value of the laser current, press the ► button for at least 5 seconds while the CD laser current is displayed, then press the ◀◀ or ▶▶ button to select T23. (For details, see "lop checked Method" on page 26.) If the ► button is pressed while T23 is displayed, the current value is displayed at "mmmm" and stored in the EEPROM.

| Display (The display part of 13 digits) | | | | | | | | | | | | |
|---|---|---|---|---|---|---|---|---|----|----|----|----|
| 1 | 2 | 3 | 4 | 5 | 6 | 7 | 8 | 9 | 10 | 11 | 12 | 13 |
| T | 2 | 3 | — | m | m | m | m | — | — | — | — | — |

5. Resetting the accumulated laser on time

To clear the accumulated laser on time, press the ► button while the accumulated laser on time is displayed (TB1: For details, see "Test Mode" on page 32.) until " * " appears at the fourth position, then press the ▶▶ button to select TB3*. If the ► button is pressed while TB3* is displayed, the accumulated laser on time of CD is cleared.

| Display (The display part of 13 digits) | | | | | | | | | | | | |
|---|---|---|---|---|---|---|---|---|----|----|----|----|
| 1 | 2 | 3 | 4 | 5 | 6 | 7 | 8 | 9 | 10 | 11 | 12 | 13 |
| T | B | Y | — | — | — | n | n | n | n | n | n | n |

(— : Off, nnnnnnn: Hour [h])

4. レーザー電流初期値の書き換え方法

レーザー電流の初期値を書き換えるには、CD レーザー電流が表示されている時に ► ボタンを 5 秒以上押し、次に ◀◀ ボタンまたは ▶▶ ボタンを押して T23 を選択します。(詳細は 26 ページ、lop 値の確認方法参照)

T23 表示時に ► ボタンを押すと、mmmm 部に現在値を表示し、EEPROM に保存します。

| 表示 (13 桁の表示部) | | | | | | | | | | | | |
|---------------|---|---|---|---|---|---|---|---|----|----|----|----|
| 1 | 2 | 3 | 4 | 5 | 6 | 7 | 8 | 9 | 10 | 11 | 12 | 13 |
| T | 2 | 3 | — | m | m | m | m | — | — | — | — | — |

5. レーザー ON 累積時間のリセット方法

レーザーON 累積時間をクリアするには、レーザーON 累積時間表示 (TB1) の時 (詳細は 32 ページ、テストモード参照) に ► ボタンを 4 桁目に ' * ' が表示されるまで押しします。▶▶ ボタンを押し、TB3* を表示させます。TB3* 表示の時、► ボタンを押すと CD レーザーON 累積時間をクリアします。

| 表示 (13 桁の表示部) | | | | | | | | | | | | |
|---------------|---|---|---|---|---|---|---|---|----|----|----|----|
| 1 | 2 | 3 | 4 | 5 | 6 | 7 | 8 | 9 | 10 | 11 | 12 | 13 |
| T | B | Y | — | — | — | n | n | n | n | n | n | n |

(— : 消灯、nnnnnnn : 時間 [h])

HOW TO REPLACE TRAVERSE UNIT (S-52,S-52ADB)

Caution: The optical pickup can be damaged easily by static electricity charged on human body. Take necessary anti-static measures when repairing around the optical pickup.

(Follow the procedure below in reverse order when reassembling.)

1. Top Cover disassembly

- (1) Remove screw A, then move the Top Cover as shown in the arrow ① direction. And detach left end of it as shown in the arrow direction.
- (2) Remove screw B, then move the Loading Unit as shown in the arrow ② direction. And detach it as shown in the arrow direction.

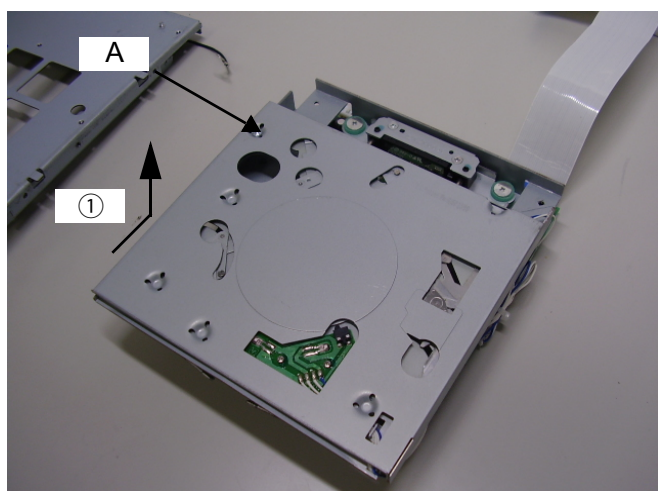

トラバースユニットの交換方法 (S-52,S-52DAB)

注意：光ピックアップは、人体に帯電した静電気等で静電破壊することがあります。光ピックアップ周辺を修理する際は、必要な静電対策を行ってください。

(組み立てるときは、逆の順序でおこなってください。)

1. トップカバーのはずしかた

- (1) ねじ A をはずしてから、Top Cover を矢印①方向に移動し、左端を矢印方向に開く様にはずします。
- (2) ねじ B をはずしてから、Loading Unit を矢印②方向に移動し、はずします。



2. Traverse Unit disassembly

- (1) Solder the short-circuit.
- (2) Remove 4 screws C.
- (3) Disconnect FFC from the Pick Up.

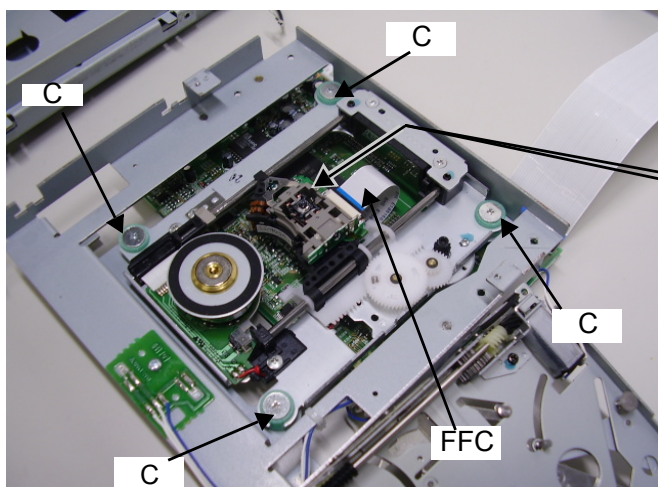

2. トラバースユニットのはずしかた

- (1) 半田付けショートをおこないません。
- (2) ねじ C 4本をはずします。
- (3) ピックアップから FFC をはずします。

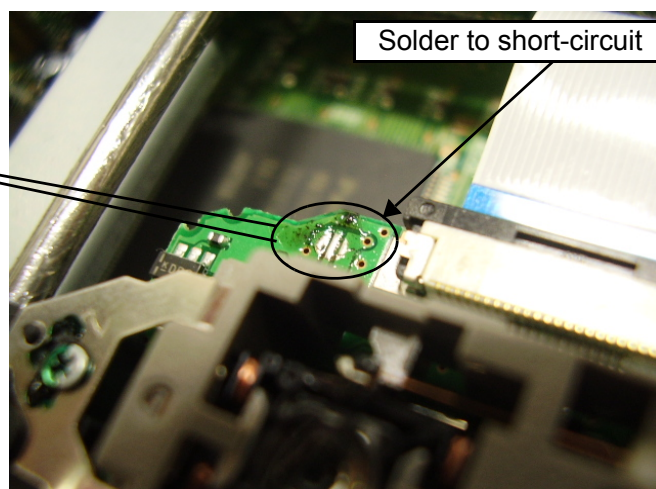

- (4) Lift the Traverse Assy and disconnect FFC.

- (4) Traverse Assy を持ち上げて、FFC をはずします。

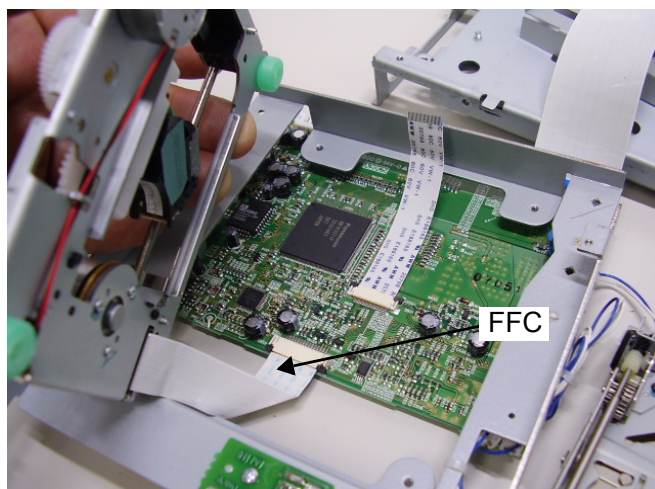

SERVICE MODE

1. Initial Setting Mode

1.1. Preparation

- (1) Equipment used: None
- (2) Unit setting: No spec other than the following procedure.

1.2. Procedure

● SYSTEM

- ※ Initialize the backup data when μ com, peripheral parts of μ com, or Main P.W.B. has been replaced in servicing.
 - ※ All user setting will be lost and its factory setting will be restored when this initialization is made. Be sure to memorize your setting for restoring again after the initialization.
- (1) Pressing the main unit's SNOOZE and the **▶▶▶** buttons simultaneously, plug the AC cord into a power outlet. The initialization mode is set. Then "INITIALIZE" is displayed on the display tube.
 - (2) Once the entire initialization procedure has been completed, the set is in the normal mode with the power turned on.

2. μ com Firm Check Mode

2.1. Preparation

- (1) Equipment used: None
- (2) Unit setting: No spec other than the following procedure.

2.2. Procedure

- ※ Use this to display the version information, etc.

NOTE)The version information is displayed 1 minute after it turns on power supply.

- To display the DAB version, press the SOURCE button before step (2) and select DAB using Jog. (EK only)
 - To display the HD version, press the SOURCE button before step (2) and select FM or AM using Jog. (E3 only)
- (1) When the STANDBY mode, the DIMMER and the **▶▶▶** buttons are simultaneously pressed. Afterwards, when the power supply of the set is turned on pressing the FUNCTION ON/OFF button, the system check mode is set.
 - (2) Press the SOURCE button and select SETUP using Jog to add the Version display mode at the head of the SETUP items. This will appear as "Version Display".
 - (3) Select Version Display and turn Jog to display. The information will be displayed in the following order each time you turn Jog: the system microcomputer versions→DSP→frontend→DM850Boot→DM850Image→DM850Config→DAB(EK only)→HD(E3 only).
 - (4) Unplug AC cord to clear this mode.

サービスモードについて

1. イニシャルモード

1.1. 準備

- (1) 使用機器：無
- (2) 本体設定：下記手順以外規定無。

1.2. 手順

● システム

- ※ サービスにて、マイコンやマイコン周辺部分やメイン基板を交換した場合は、バックアップデータの初期化を行う。
 - ※ 初期化を行うと設定した内容が工場出荷状態に戻るため、あらかじめ設定内容を控えておき初期化後に再設定する。
- (1) 本体 SNOOZE ボタンと **▶▶▶** ボタンを同時に押しながら、AC コードを接続するとイニシャルモードが設定され、"INITIALIZE" が表示される。
 - (2) 全ての初期化完了後、通常モードの電源 ON の状態になる。

2. マイコンファームチェックモード

2.1. 準備

- (1) 使用機器：無
- (2) 本体設定：下記手順以外規定無。

2.2. 手順

- ※ バージョン表示等をおこなう。

注)・DM850 のバージョンの表示は、電源を入れてから 1 分後に表示される。

- DAB のバージョン表示は (2) の操作の前に SOURCE ボタンを押し、Jog で DAB を選択してから行う。(EK のみ)
 - HD のバージョン表示は (2) の操作の前に SOURCE ボタンを押し、Jog で FM または AM を選択してから行う。(E3 のみ)
- (1) 本体 DIMMER ボタン、**▶▶▶** ボタンを同時に押し、AC コードを接続する。その後、FUNCTION ON/OFF ボタンを押してセットの電源を入れるとシステムチェックモードが設定される。
 - (2) SOURCE ボタンを押し、Jog で SETUP を選択すると、SETUP 項目の先頭に Version 表示モードが追加され、"Version Display" と表示される。
 - (3) Version Display を選択すると、Jog をまわす毎に、システムマイコンのバージョン→DSP → Frontend → DM850Boot → DM850Image → DM850Config → DAB(EK のみ) → HD(E3 のみ) の順に表示される。
 - (4) AC コードを抜くことにより、システムチェックモードを解除する。

3. Heat Run Mode (S-52)

3.1. preparation

- (1) Equipment used: CD
- (2) Unit setting : No spec other than the following procedure.

3.2. procedure

※ Perform heat run of the CD.

- (1) Pressing the ▲ and DIMMER buttons simultaneously, plug the AC cord into a power outlet. This sets the heat run mode.
- (2) Check both the SOURCE LED and "RETURN LED" indicators light on the fluorescent display tube.
- (3) Press the ▶/■ button after inserting a disk (or with a disk already inserted) to execute the heat run mode. All tracks on the disc will be played.
NOTE) ・ If disc being used has less than 20 tracks, play all tracks. If disc has 21 or more tracks, skip to final track after playback of first track has finished.
- (4) Once playback is completed, eject and insert the disk and repeat the playback operation in step (3).
- (5) If there is an error while in the Heat run mode, the error is displayed and the stop mode is set with the status at that time.
NOTE) ・ The buttons on the remote control unit will not work during the heat run mode.
(If the set's power is turned off pressing the FUNCTION ON/OFF button, the CD stops and the heat run mode is canceled.)

| Error code | Error contents |
|-----------------|---|
| 0x0000 | No error |
| 0x0003 | System Interface error |
| 0x0500 - 0x0501 | File Check error |
| 0x0F01 | Fatal error on CD ROM drive (Time out etc.) |
| 0x0400 - 0x040E | CD ROM Drive error |

3. ヒートランモード (S-52)

3.1. 準備

- (1) 使用機器：CD
- (2) 本体設定：下記設定以外規定無。

3.2. 手順

※ CD のヒートランをおこなう。

- (1) 本体の ▲ ボタンと DIMMER ボタンを同時に押しながら AC コードをコンセントへ接続すると、ヒートランモードが設定される。
- (2) SOURCE LED と RETURN LED が両方とも点灯することを確認する。
- (3) ディスクが挿入された状態（挿入中も含む）で ▶/■ ボタンを押してヒートランモードを実行し、ディスクに収録されている全ての曲を再生する。
注) ・ 使用ディスクが 20 トラック以内の時は全トラックを再生し、21 トラック以上の時は、1 トラックと最終トラックを再生する。
- (4) 再生終了後、ディスクをスロットから取り出し再び挿入、(3) の再生動作をおこなう。
- (5) ヒートランモード中にエラーが発生すると、エラーを表示し、その時の状態で停止する。
注) ・ ヒートランモード中は、リモコンのボタンは動作しない。
(FUNCTION ON/OFF ボタンを押してセットの電源を OFF にすると、CD が停止し、ヒートランモードが解除される為。)

| エラーコード | エラー内容 |
|-----------------|-------------------------------|
| 0x0000 | 正常終了 |
| 0x0003 | システムインターフェースエラー |
| 0x0500 - 0x0501 | File Check エラー |
| 0x0F01 | CD ROM Drive で致命的な障害（タイムアウト等） |
| 0x0400 - 0x040E | CD ROM Drive エラー |

4. Test mode (S-52)

4.1. Entering the test mode

To set the test mode, press the RETURN button before pressing the ►|| button in the heat run mode. Not insert the disc.
 (To set the heat run mode, connect the AC cord and press the FUNCTION ON/OFF button while pressing the ▲ and DIMMER buttons simultaneously to turn on the set power. When the Heat run mode is set, the SOURCE LED and RETURN LED indicators light.)

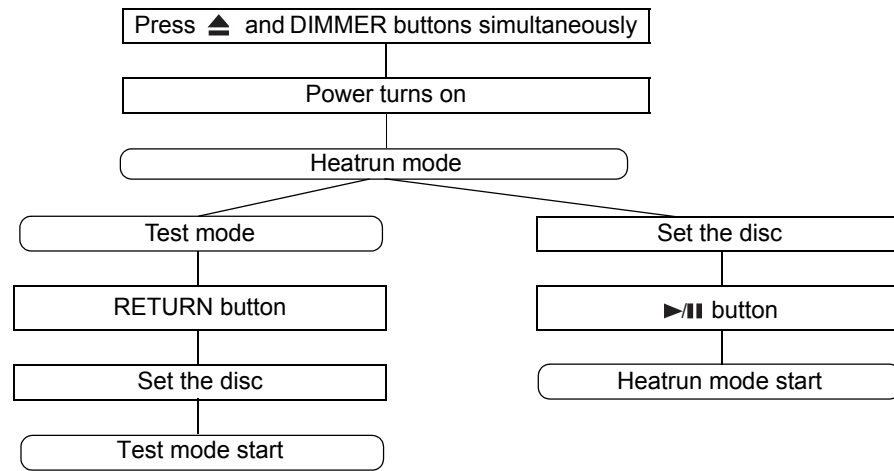

Display when test mode entered

| | | | | | | | | | | | |
|---------|--|---|---|---|---|--|---|---|---|---|--|
| Display | | | | | | | | | | | |
| | | T | E | S | T | | M | O | D | E | |

4.2. Selecting the mode

The following modes are available.

- (1) Laser on/off (CD) mode : T2
- (2) Servo adjustment value display mode : T3
- (3) Trace mode (error rate display) : T7
- (4) Accumulated laser on time : TB

① When the ►|| button is pressed after entering the test mode, the display switches in the order: T2, T3, T7, TB, T2 ...

| | | | | | | | | | | | |
|---------|---|--|---|---|---|---|---|---|---|---|---|
| Display | | | | | | | | | | | |
| T | 2 | | L | a | s | e | r | O | n | O | f |

| | | | | | | | | | | | |
|---------|---|--|---|---|---|---|---|--|---|---|---|
| Display | | | | | | | | | | | |
| T | 3 | | S | e | r | v | o | | A | d | j |

| | | | | | | | | | | | |
|---------|---|--|---|---|---|---|---|--|---|---|---|
| Display | | | | | | | | | | | |
| T | 7 | | T | r | a | c | e | | M | o | d |

| | | | | | | | | | | | |
|---------|---|--|---|---|---|---|---|---|---|---|---|
| Display | | | | | | | | | | | |
| T | B | | L | a | s | e | r | O | n | T | i |

4. テストモード (S-52)

4.1. テストモードの設定

テストモードの設定はヒートランモード時に►||ボタンを押す前に RETURN ボタンを押すことでおこなう。ディスクは挿入していないこと。
 (ヒートランモードの設定は▲ ボタンと DIMMER ボタンを同時に押しながら、AC コードを接続し、FUNCTION ON/OFF ボタンを押してセットの電源を入れる。ヒートランモードになると SOURCE LED と RETURN LED が点灯する。)

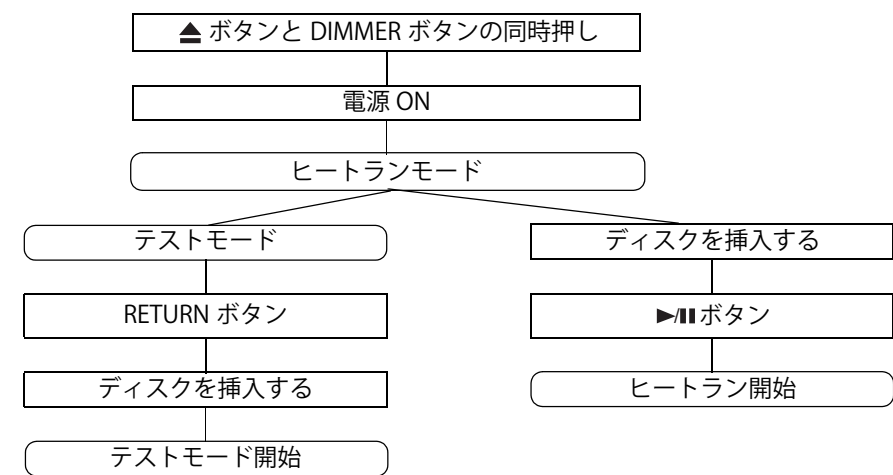

テストモード設定時の表示

| | | | | | | | | | | | |
|----|--|---|---|---|---|--|---|---|---|---|--|
| 表示 | | | | | | | | | | | |
| | | T | E | S | T | | M | O | D | E | |

4.2. モードの選択

モードには、次のモードがある。

- (1) レーザー ON/OFF(CD) モード : T2
- (2) サーボ調整値表示モード : T3
- (3) トレースモード(エラーレート表示) : T7
- (4) レーザー ON 累積時間 : TB

①テストモード中に►||ボタンを押すと、T2,T3,T7,TB,T2...の順に表示される。

| | | | | | | | | | | | |
|----|---|--|---|---|---|---|---|---|---|---|---|
| 表示 | | | | | | | | | | | |
| T | 2 | | L | a | s | e | r | O | n | O | f |

| | | | | | | | | | | | |
|----|---|--|---|---|---|---|---|--|---|---|---|
| 表示 | | | | | | | | | | | |
| T | 3 | | S | e | r | v | o | | A | d | j |

| | | | | | | | | | | | |
|----|---|--|---|---|---|---|---|--|---|---|---|
| 表示 | | | | | | | | | | | |
| T | 7 | | T | r | a | c | e | | M | o | d |

| | | | | | | | | | | | |
|----|---|--|---|---|---|---|---|---|---|---|---|
| 表示 | | | | | | | | | | | |
| T | B | | L | a | s | e | r | O | n | T | i |

4.3. Setting the mode

With the mode selected, press the ►/■ button to set that mode.

- ① In the laser on/off (CD) mode, laser on/off control is executed and the laser current is displayed.
To save the current laser current value, press and hold in the ►/■ button for at least 5 seconds to turn off the "mmmm" section of the display, then press the ►/■ button and select T23. When the ►/■ button is pressed while T23 is displayed, the data is displayed in the "mmmm" section.

For the CD laser

| Display | | | | | | | | | | | | |
|---------|---|---|---|---|---|---|---|---|---|---|---|---|
| T | 2 | 1 | — | m | m | m | m | — | n | n | n | n |

(— : Off, CD laser, Stored data: mm.mm [mA], Current value: nn.nn [mA])

- ② In the servo adjustment value display mode (See "Table 1 - Servo adjustment value display mode details")

| Display | | | | | | | | | | | | |
|---------|---|---|---|---|---|---|---|---|---|---|---|---|
| T | X | X | — | — | — | — | — | — | n | n | n | n |

(XX : Selection mode, n : Adjustment value (HEX))

- ③ In the trace mode (error rate display), select the trace of the innermost circumference of 1 layer.

| Display | | | | | | | | | | | | |
|---------|---|---|---|---|---|---|---|---|---|---|---|---|
| T | 7 | 1 | F | F | F | F | F | F | F | F | F | F |

(F : When address and error rate not set, F is displayed.)

- ④ Displaying the accumulated laser on time (stored in the EEPROM)

| Display | | | | | | | | | | | | |
|---------|---|---|---|---|---|---|---|---|---|---|---|---|
| T | B | 1 | — | — | — | n | n | n | n | n | n | n |

(nnnnn: Time [h])

※ Fractions of hours are counted up one hour on the display.

4.3. モードの確定

モードを選択してある状態で►/■ボタンを押すとモードを確定する。

- ①レーザー ON/OFF(CD) モードの場合、レーザーの ON/OFF 制御を実行し、レーザー電流を表示する。
現在のレーザー電流値を保存する場合、►/■ボタンを5秒以上押し続け、mmmm部を非表示にし、►/■ボタンを押して、T23を選択する。T23を表示時に►/■ボタンを押すと、mmmm部にデータが表示される。

CDレーザーの場合

| 表示 | | | | | | | | | | | | |
|----|---|---|---|---|---|---|---|---|---|---|---|---|
| T | 2 | 1 | — | m | m | m | m | — | n | n | n | n |

(— : 消灯、CDレーザー、保存データ: mm.mm[mA], 現在値: nn.nn[mA])

- ②サーボ調整値表示モードの場合 (表1サーボ調整値表示モード詳細参照)

| 表示 | | | | | | | | | | | | |
|----|---|---|---|---|---|---|---|---|---|---|---|---|
| T | X | X | — | — | — | — | — | — | n | n | n | n |

(XX: 選択モード、n: 調整値 (HEX))

- ③トレースモード (エラーレート表示) の場合は、1層内周のトレースを選択する。

| 表示 | | | | | | | | | | | | |
|----|---|---|---|---|---|---|---|---|---|---|---|---|
| T | 7 | 1 | F | F | F | F | F | F | F | F | F | F |

(F: アドレス及びエラーレートは未確定時、Fを表示する。)

- ④レーザー ON 累積時間 (EEPROM に記憶) を表示する。

| 表示 | | | | | | | | | | | | |
|----|---|---|---|---|---|---|---|---|---|---|---|---|
| T | B | 1 | — | — | — | n | n | n | n | n | n | n |

(nnnnn: 時間 [h])

※ 1時間未満は切り上げて表示する。

4.4. Change within the mode

Changes within modes are made by pressing the ◀◀ and ▶▶ buttons while the mode is set.

- ① In the laser on/off mode, laser on/off control is executed and the laser current is displayed.

For the CD laser

| Display | | | | | | | | | | | | |
|---------|---|---|---|---|---|---|---|---|---|---|---|---|
| T | 2 | 1 | — | m | m | m | m | — | n | n | n | n |

(— : Off, CD laser, Stored data: mm.mm [mA], Current value: nn.nn [mA])

When there is no saved data

| Display | | | | | | | | | | | | |
|---------|---|---|---|---|---|---|---|---|---|---|---|---|
| T | 2 | 1 | — | — | — | — | — | — | n | n | n | n |

(— : Off, nn.nn [mA])

To store the current value, press the ▶▶ button for " * " appears at the fourth position, then press the ◀◀ or ▶▶ button to select T23.

If the ▶▶ button is pressed while T23 is displayed, the current value is displayed at "mmmm" and stored in the EEPROM.

| Display | | | | | | | | | | | | |
|---------|---|---|---|---|---|---|---|---|---|---|---|---|
| T | 2 | 3 | — | m | m | m | m | — | n | n | n | n |

(— : Off, nn.nn [mA])

If the current value is over 100 mA, the 4th and 9th digit sections are used.

- ② In the servo adjustment value display mode (See "Table 1 - Servo adjustment value display mode details")

| Display | | | | | | | | | | | | |
|---------|---|---|---|---|---|---|---|---|---|---|---|---|
| T | X | X | — | — | n | n | n | n | n | n | n | n |

(XX : Selection mode, n: Adjustment value (HEX))

For the adjustment values, 0's are added in front of the effective number of bytes.

(Ex.: If the value is 0x123 for 4-byte data, "00 00 01 23" is displayed.)

- ③ In the trace mode (error rate display) (See "Table 2 - Trace mode details")

| Display | | | | | | | | | | | | |
|---------|---|---|---|---|---|---|---|---|---|---|---|---|
| T | Y | Y | F | F | F | F | F | F | F | F | F | F |

(YY : Selection mode [71 to 94], F: When address and error rate not set, F is displayed.)

- ④ In the accumulated laser on time display

| Display | | | | | | | | | | | | |
|---------|---|---|---|---|---|---|---|---|---|---|---|---|
| T | B | 1 | — | — | — | n | n | n | n | n | n | n |

(nnnnnn: Time [h]) ※ If the current value is over 100 mA, the 4th and 9th digit sections are used.

To clear the accumulated laser on time, press the ▶▶ button while the accumulated laser on time is displayed (TB1) until " * " appears at the fourth position, then the accumulated laser on time of CD is cleared.

When TB1 is selected, "nnnnnn" is displayed as 0 so you can check.

4.4. モード内での変更

モードを確定してある状態で◀◀ボタンまたは▶▶ボタンを押すとモード内での変更をおこなう。

- ①レーザー ON/OFF モードの場合、レーザーの ON/OFF 制御を実行し、レーザー電流を表示する。

CD レーザーの場合

| 表示 | | | | | | | | | | | | |
|----|---|---|---|---|---|---|---|---|---|---|---|---|
| T | 2 | 1 | — | m | m | m | m | — | n | n | n | n |

(— : 消灯、CD レーザー、保存データ: mm.mm[mA], 現在値: nn.nn[mA])

保存データなしの場合

| 表示 | | | | | | | | | | | | |
|----|---|---|---|---|---|---|---|---|---|---|---|---|
| T | 2 | 1 | — | — | — | — | — | — | n | n | n | n |

(— : 消灯、nn.nn[mA])

現在値を保存するには、▶▶ボタンを4桁目に "*" が表示されるまで押し、次に◀◀ボタンまたは▶▶ボタンを押して T23 を選択する。T23 表示時に、▶▶ボタンを押すと、mmmm 部に現在値を表示し、EEPROM に保存される。

| 表示 | | | | | | | | | | | | |
|----|---|---|---|---|---|---|---|---|---|---|---|---|
| T | 2 | 3 | — | m | m | m | m | — | — | — | — | — |

(— : 消灯、mm.mm[mA])

電流値が 100mA 以上の場合は、4桁、9桁部分を使用。

- ②サーボ調整値表示モードの場合 (表1サーボ調整値表示モード詳細参照)

| 表示 | | | | | | | | | | | | |
|----|---|---|---|---|---|---|---|---|---|---|---|---|
| T | X | X | — | — | n | n | n | n | n | n | n | n |

(XX: 選択モード、n: 調整値 (HEX))

調整値は、有効バイト数分先頭に 0 をつける。

(例: 4 バイトデータで値が 0x123 の場合は "00 00 01 23")

- ③トレースモード (エラーレート表示) の場合 (表2トレースモード詳細参照)

| 表示 | | | | | | | | | | | | |
|----|---|---|---|---|---|---|---|---|---|---|---|---|
| T | Y | Y | F | F | F | F | F | F | F | F | F | F |

(YY: 選択モード [71 ~ 94]、F: アドレス及びエラーレートは未確定時、F を表示する。)

- ④レーザー ON 累積時間を表示場合

| 表示 | | | | | | | | | | | | |
|----|---|---|---|---|---|---|---|---|---|---|---|---|
| T | B | 1 | — | — | — | n | n | n | n | n | n | n |

(nnnnnn: 時間 [h]) ※ 1 時間未満は切り上げて表示する。

レーザー ON 累積時間をクリアする場合、レーザー ON 累積時間表示時 (TB1) のとき、▶▶ボタンを4桁目に "*" が表示されるまで押し、CD レーザー ON 累積時間をクリアする。TB1 を選択すると、nnnnnn 部が 0 表示になり確認できる。

4.5. Execution of trace mode (error rate display) (See "Table 2 - Trace mode details")

Trace will be performed if the ▶||| button is pushed after choosing operation.

| Display | | | | | | | | | | | | |
|---------|---|---|---|---|---|---|---|---|---|---|---|---|
| T | Y | Y | m | m | m | m | m | m | l | l | l | l |

(YY : selection mode [71 to 94], m : address [LBA][HEX], l : error rate [COUNT/SEC] [HEX])

Note) CD : Error rate of 75 frames is displayed (1 second).

The mode chosen when selection mode was changed into the trace execution and the ▶||| button was pushed is performed from the beginning.

When the ▶||| button is pushed without changing selection mode, the mode under selection is performed from the beginning. (If the ▶||| button is pushed, the address corresponding to the chosen mode will be searched again.)

The pause mode is set after tracing is completed.

4.6. Other operations

- ① When the RETURN button is pressed, the mode returns to the previously selected mode.

(1) Test mode detailed table

Table 1: Servo adjustment value display mode details

| XXX | Name | Size | Meaning | Remarks |
|-----|----------|--------|---|--|
| T31 | fbal0 | 16bits | CD layer focus balance adjustment value | FBAL range: 0x8000 < FBAL < 0x7FC0(Center:0x0000) |
| T32 | tbal0 | 16bits | CD layer tracking balance adjustment value | TBAL range: 0x0000 < TBAL < 0x003F |
| T33 | fcga0 | 16bits | CD layer focus Loop Gain adjustment value | 1x for 0x100 [0x200 (2x) set to Typ. (1x for 0x100, 2x for 0x200. Y/0x100 ratio calculation.) Adjustment value 0x200 sets so that gain crossover reaches target. |
| T34 | tkga0 | 16bits | CD layer tracking Loop Gain adjustment value | 1x for 0x100 [0x200 (2x) set to Typ. (1x for 0x100, 2x for 0x200. Y/0x100 ratio calculation.) Adjustment value 0x202 sets so that gain crossover reaches target. |
| T39 | Asoffs | 16bits | AS signal Offset value | Upper 10 bit is valid |
| T40 | Envoffse | 16bits | ENV signal Offset adjustment value | Upper 10 bit is valid |
| T41 | Foffse | 16bits | FE signal Offset adjustment value | Upper 10 bit is valid |
| T42 | Teoffse | 16bits | TE signal Offset adjustment value | Upper 10 bit is valid |
| T43 | RFfc | 8bits | RF signal frequency adjustment value | |
| T44 | RFbst | 8bits | RF signal Boost adjustment value | Adjustment range : 0x0000 ~ 0x001F 0x0000 : 0dB 0x001F : 14dB |
| T45 | RFgdl | 8bits | RF signal low range group delay adjustment value | |
| T46 | RFgdh | 8bits | RF signal high range group delay adjustment value | |

Table 2: Trace mode details

| YY | Contents | Contents supplement |
|----|--|-------------------------------------|
| 73 | A display of C1 error detection number of the inner circumference of an address. | CD : C1 error detection number (x3) |
| 77 | A display of C1 error detection number of the central circumference of an address. | CD : C1 error detection number (x3) |
| 81 | A display of C1 error detection number of the outer circumference of an address. | CD : C1 error detection number (x3) |

4.5. トレースモード (エラーレート表示) の実行 (表2 トレースモード詳細 参照)

動作を選択した後、▶||| ボタンを押すとトレースを実行する。

| 表示 | | | | | | | | | | | | |
|----|---|---|---|---|---|---|---|---|---|---|---|---|
| T | Y | Y | m | m | m | m | m | m | l | l | l | l |

(YY: 選択モード [71 ~ 94]、m: アドレス [PBA][HEX]、l: エラーレート [CONT][DEC])

注) : 表示するエラーレートは、75 フレーム (1 秒) 分の値。

トレース実行中に選択モードを変更し、▶||| ボタンを押すと選択したモードを最初から実行する。

選択モードを変更せずに▶||| ボタンを押した場合も、選択中のモードを最初から実行する。

(▶||| ボタンを押すと、選択しているモードに対応したアドレスを再度サーチする。)

トレース終了時は、PAUSE 状態になります。

4.6. その他の動作

- ① RETURN ボタンを押すと、前の選択モードに戻る。

(1) テストモード詳細一覧表

表 1 サーボ調整値表示モード詳細

| XXX | 名称 | サイズ | 意味 | 備考 |
|-----|----------|-------|--------------------------|---|
| T31 | fbal0 | 16ビット | CD 層フォーカスバランス調整値 | FBAL の範囲は 0x8000 < FBAL < 0x7FC0。(センター: 0x0000) |
| T32 | tbal0 | 16ビット | CD 層トラッキングバランス調整値 | TBAL の範囲は 0x0000 < TBAL < 0x003F。 |
| T33 | fcga0 | 16ビット | CD 層フォーカス Loop Gain 調整値 | 0x100 で 1 倍 [0x200(2 倍) を Typ に設定する] (0x100 で 1 倍、0x200 で 2 倍。Y/0x100 の比率計算) 調整値 0x200 で Gain 交点が目標ターゲットになる様設定している。 |
| T34 | tkga0 | 16ビット | CD 層トラッキング Loop Gain 調整値 | 0x100 で 1 倍 [0x200(2 倍) を Typ に設定する] (0x100 で 1 倍、0x200 で 2 倍。Y/0x100 の比率計算) 調整値 0x202 で Gain 交点が目標ターゲットになる様設定している。 |
| T39 | Asoffs | 16ビット | AS 信号の Offset 値 | 上位 10bit が有効 |
| T40 | Envoffse | 16ビット | ENV 信号の Offset 調整値 | 上位 10bit が有効 |
| T41 | Foffse | 16ビット | FE 信号の Offset 調整値 | 上位 10bit が有効 |
| T42 | Teoffse | 16ビット | TE 信号の Offset 調整値 | 上位 10bit が有効 |
| T43 | RFfc | 8ビット | RF 信号の周波数調整値 | |
| T44 | RFbst | 8ビット | RF 信号の Boost 調整値 | 調整範囲: 0x0000 ~ 0x001F 0x0000 : 0dB 0x001F : 14dB |
| T45 | RFgdl | 8ビット | RF 信号の低域群遅延調整値 | |
| T46 | RFgdh | 8ビット | RF 信号の高域群遅延調整値 | |

表 2 トレースモード詳細

| YY | 内容 | 補足説明 |
|----|----------------------|---------------------|
| 73 | 内周の C1 誤り検出数とアドレスの表示 | CD 時は C1 誤り検出数。(x3) |
| 77 | 中周の C1 誤り検出数とアドレスの表示 | CD 時は C1 誤り検出数。(x3) |
| 81 | 外周の C1 誤り検出数とアドレスの表示 | CD 時は C1 誤り検出数。(x3) |

5. Product Mode

5.1. Setting the product mode

※ The TUNER and AVAMP set to the product mode.

- (1) Pressing the **◀◀** and SNOOZE buttons simultaneously, plug the AC cord into a power outlet. This sets the product mode.
- (2) After power supply turn on, the function is displayed.
- (3) In the product mode:
 - AUDYSSEY is turned OFF.
 - Selecting DAB sets 227.36MHz. (EK only)
 - Selecting XM displays "POWER CHECK" and 1kHz/-20dBFS L+R is automatically detected for audio output. 1kHz/0dB (automatically becomes 1kHz/-20dB), 1kHz/-20dB, 1kHz/-60dB and MUTE ON can be selected using the **▶▶** button. (E3 only)
 - Pressing ALARM1 or ALARM2 outputs a BEEP tone. Each time you have performed this operation, unplug the AC cord.
- (4) Unplug AC cord to clear this mode.

6. Version up Mode by DPMS

6.1. Setting the version up mode by DPMS

※ Version up by DPMS.

- (1) Pressing and hold in the SLEEP and SOURCE buttons simultaneously, plug the AC cord into a power outlet. This sets the DPMS version up mode.
- (2) After power supply turn on, the function is displayed.

7. Direct Version up Mode

7.1. Setting the direct version up mode

※ Versions are updated compulsorily using DPMS.

- (1) Pressing the **◀◀** and ALARM SETTING buttons simultaneously, plug the AC cord into a power outlet. This compulsorily sets the version up mode by DPMS.
- (2) This is used when the system microcomputer fails during a version update or the system microcomputer does not start up.

8. All segments is Turning on Mode

8.1. Setting the all segments is turning on mode

※ All segment of LCD and LED is turning on.

- (1) Pressing the **▶▶** and ALARM SETTING buttons simultaneously, plug the AC cord into a power outlet. This sets the all segments is turning on mode.

9. EEPROM Check Mode

9.1. Setting the EEPROM check mode

※ Checking the EEPROM.

- (1) Pressing the **▶▶** and SLEEP buttons simultaneously, plug the AC cord into a power outlet. This sets the EEPROM mode.

5. プロダクトモード

5.1. プロダクトモードの設定

※ TUNER,AVAMP をプロダクトモードにする。

- (1) 本体の**◀◀**ボタンと SNOOZE ボタンを同時に押しながら AC コードを接続すると、プロダクトモードが設定される。
- (2) 電源 ON 後はファンクション表示される。
- (3) プロダクトモードでは
 - AUDYSSEY を OFF にする。
 - DAB を選択すると 227.36MHz に設定する。(EK のみ)
 - XM を選択すると "POWER CHECK" を表示し、自動で 1kHz/-20dB FS L+R を検出して音声出力する。**▶▶**ボタンで 1kHz/0dB(自動で 1kHz/-20dB になる)、1kHz/-20dB、1kHz/-60dB、MUTE ON を選択することができる。(E3 のみ)
 - ALARM1 または ALARM2 ボタンを押すと BEEP 音を出力する。尚、この操作を行った場合はその都度 AC コードを抜くこと。
- (4) AC コードを抜くことにより、プロダクトモードを解除する。

6. DPMS によるバージョンアップモード

6.1. DPMS によるバージョンアップモードの設定

※ DPMS を用いて、バージョンアップを行う。

- (1) 本体 SLEEP ボタンと SOURCE ボタンを同時に押しながら AC コードを接続すると、DPMS バージョンアップモードが設定される。
- (2) サーバー上に、セット内のバージョンよりも新しいバージョンが存在すれば、バージョンアップを開始する。

7. ダイレクトバージョンアップモード

7.1. ダイレクトバージョンアップモードの設定

※ DPMS を用いて、強制的にバージョンアップを行う。

- (1) 本体**◀◀**ボタンと ALARM SETTING ボタン押しながら AC コードを接続すると、強制的に DPMS によるバージョンアップモードが設定される。
- (2) システムマイコンのバージョンアップを途中で失敗し、システムマイコンが起動しなくなった時に使用する。

8. 全点灯モード

8.1. 全点灯モードの設定

※ LCD 及び LED の全点灯を行う。

- (1) 本体**▶▶**ボタンと ALARM SETTING ボタンを同時に押しながら AC コードを接続すると、全点灯モードが設定される。

9. EEPROM チェックモード

9.1. EEPROM チェックモードの設定

※ EEPROM のチェックを行う。

- (1) 本体**▶▶**ボタンと SLEEP ボタンを同時に押しながら AC コードを接続すると、EEPROM のチェックモードが設定される。

TROUBLE SHOOTING

1. LCD doesn't display

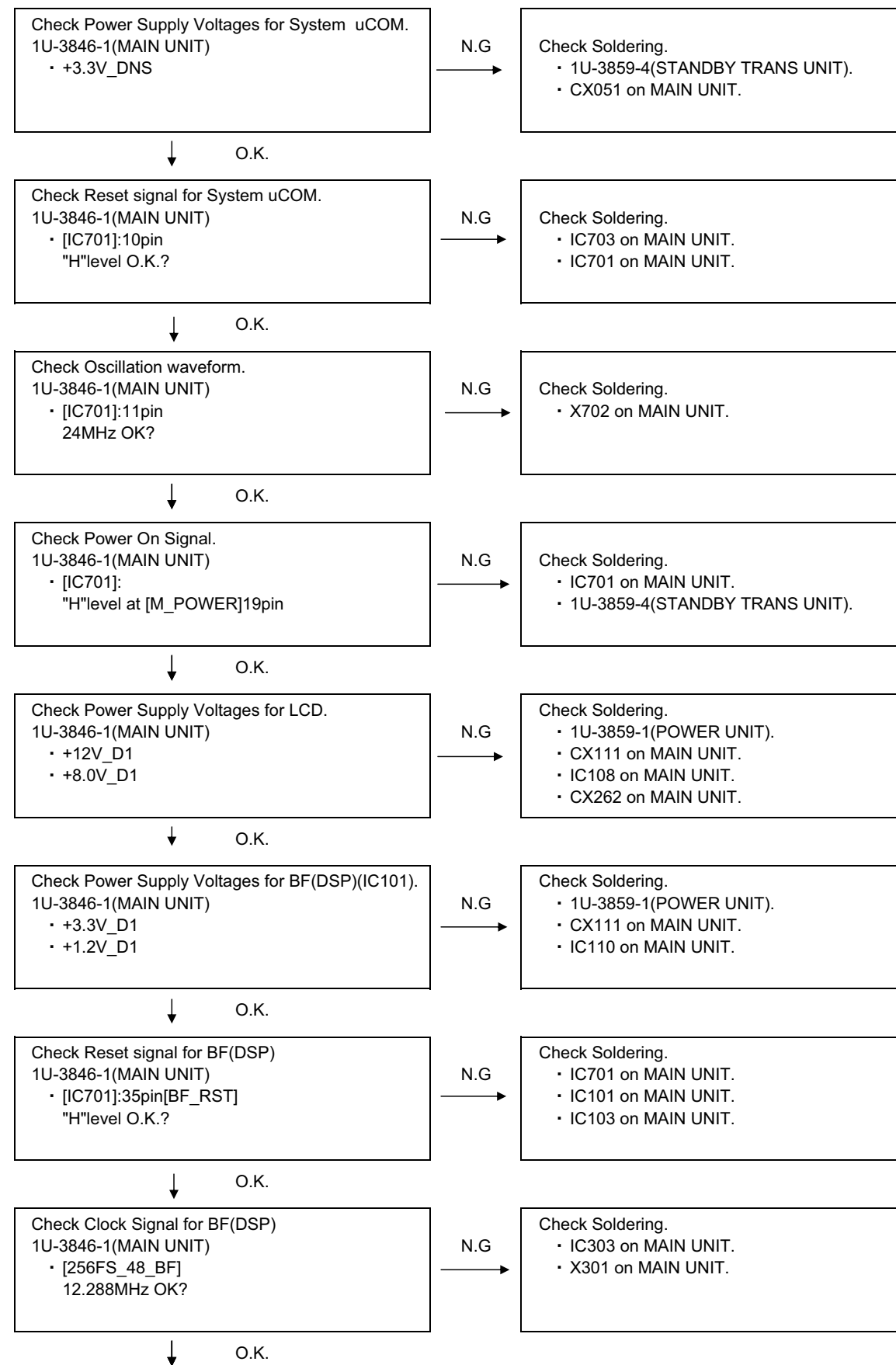
(1) Check the Set-up process of System μ -COM and BF(DSP)

トラブルシューティング

1. LCD表示せず

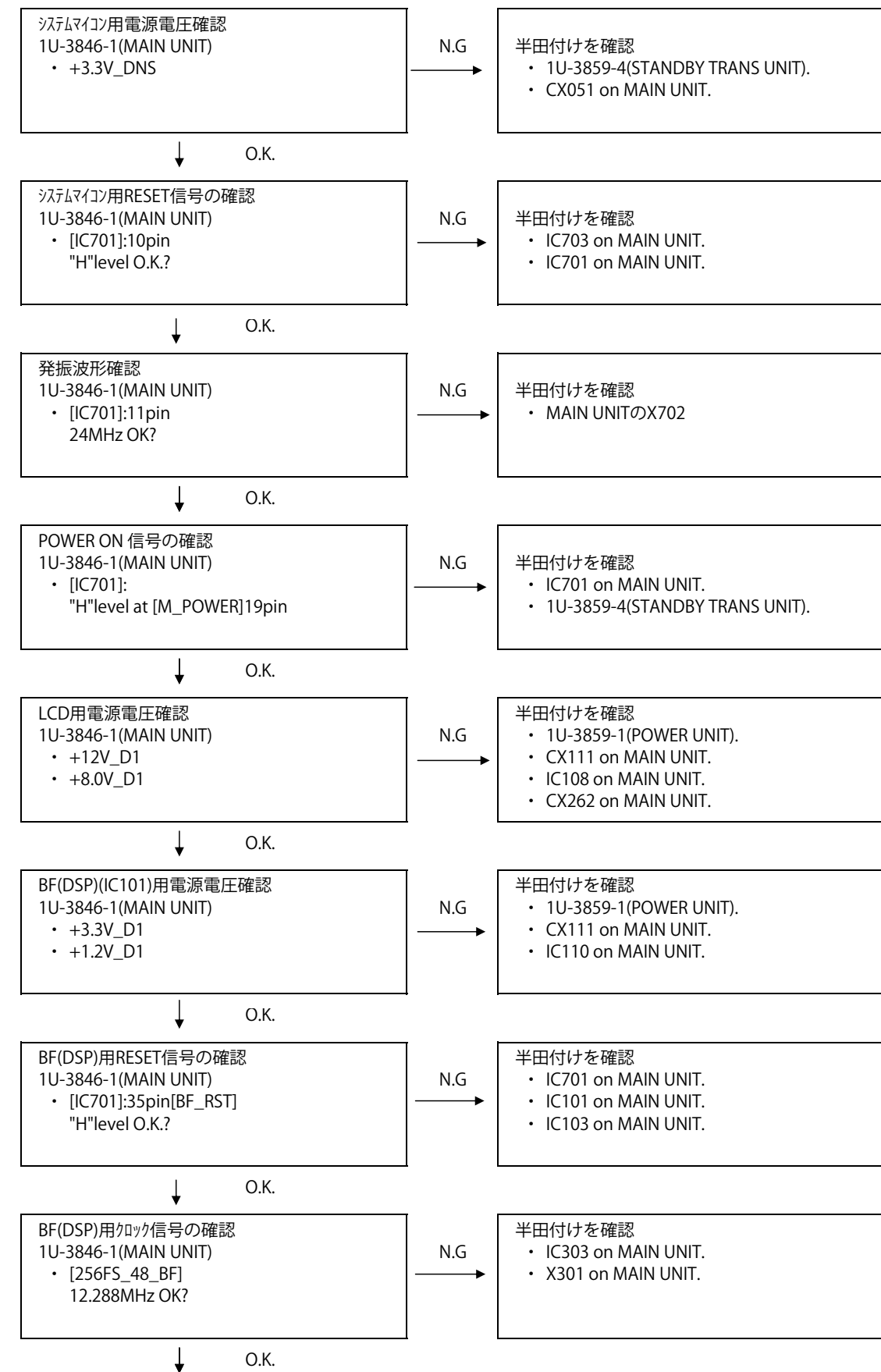
(1) システム μ -COMとBF(DSP)立ち上がりチェック工程

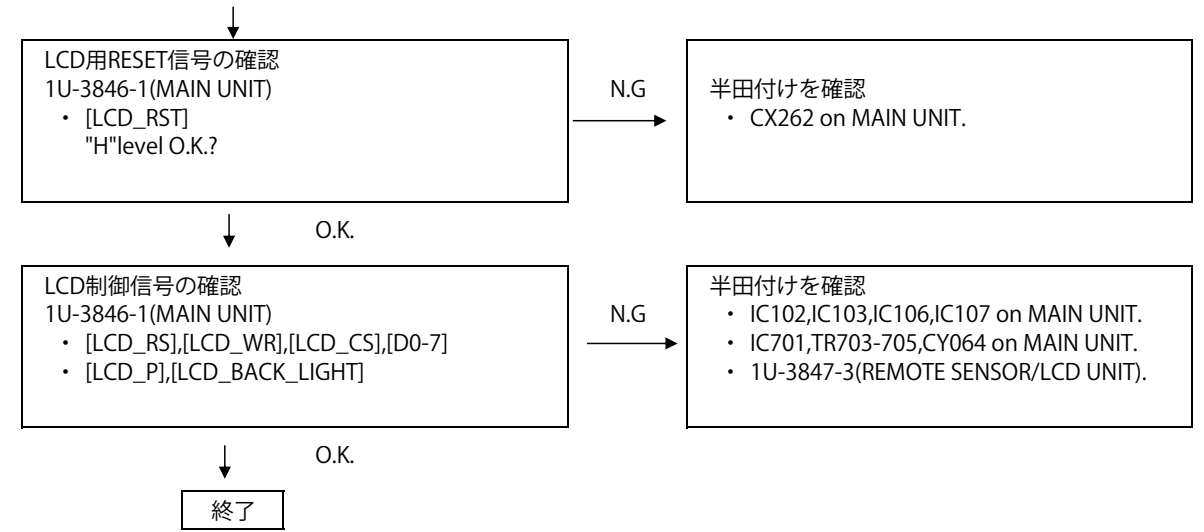
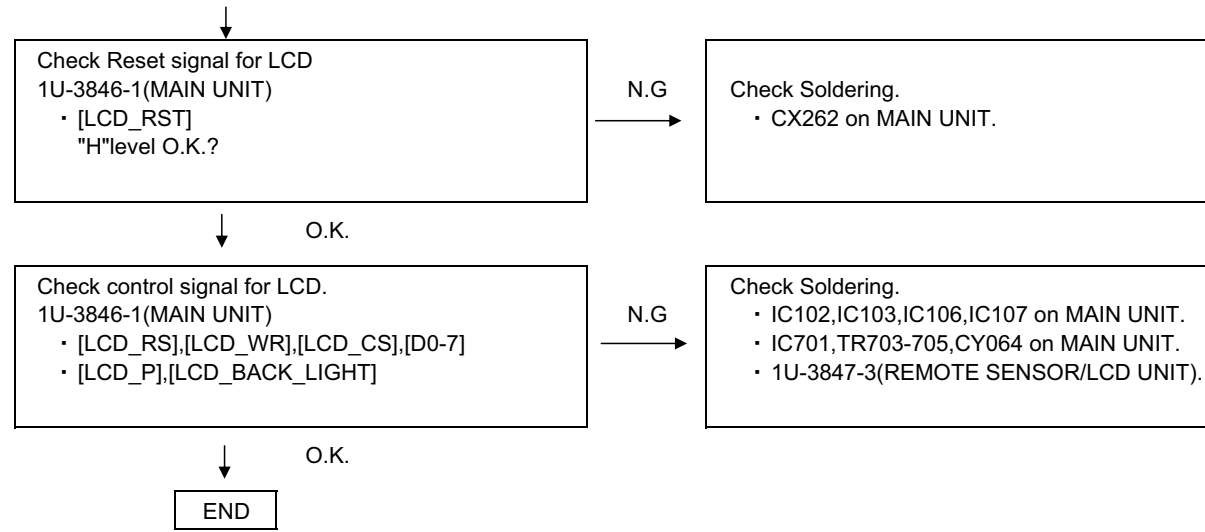

2. CD doesn't playback(S-52,S-52DAB only)

(1) Check the Set-up process of BF(DSP) and FE Drive

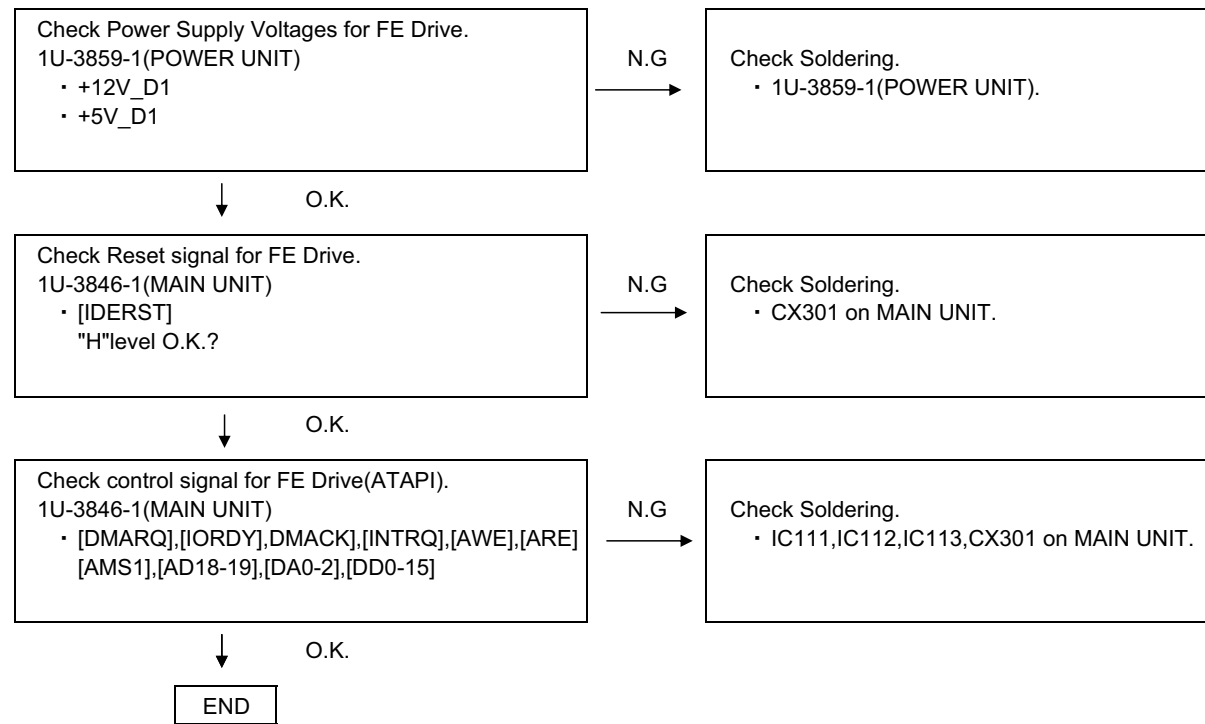

2. CD再生せず(S-52,S-52DABのみ)

(1) BF(DSP)とFEドライブ立ち上がりチェック工程

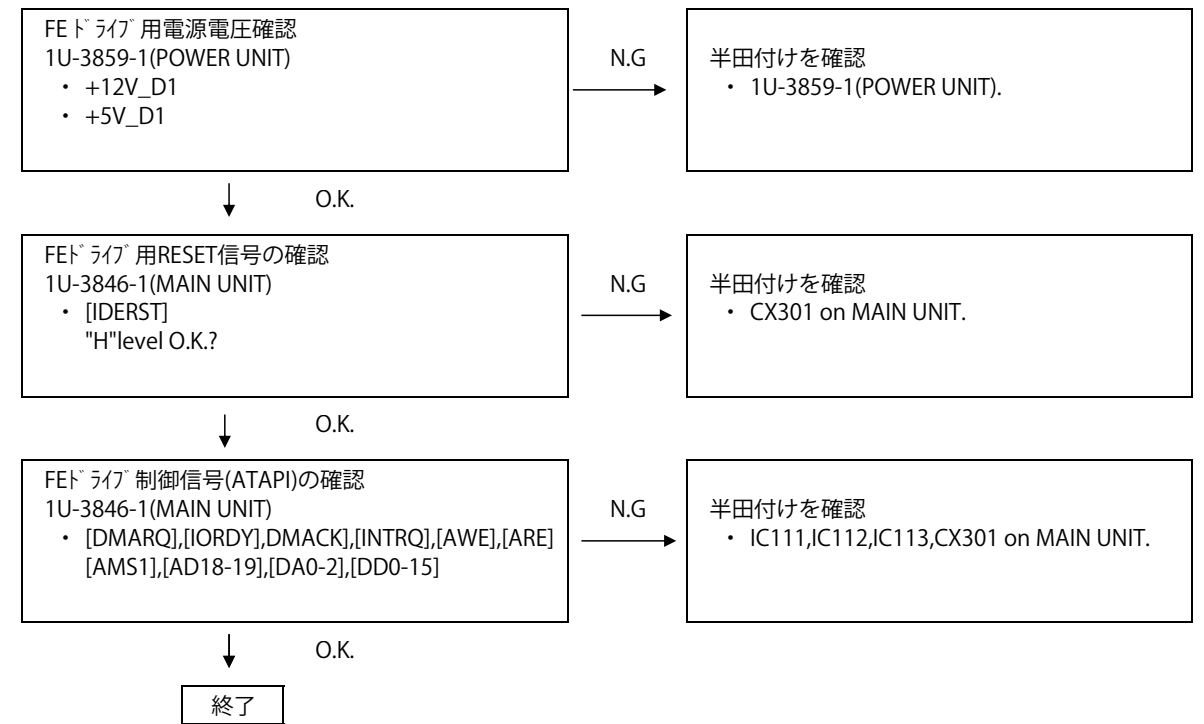

3. No Sound,Noise generated

(1) CD PLAY(S-52,S-52DAB only)

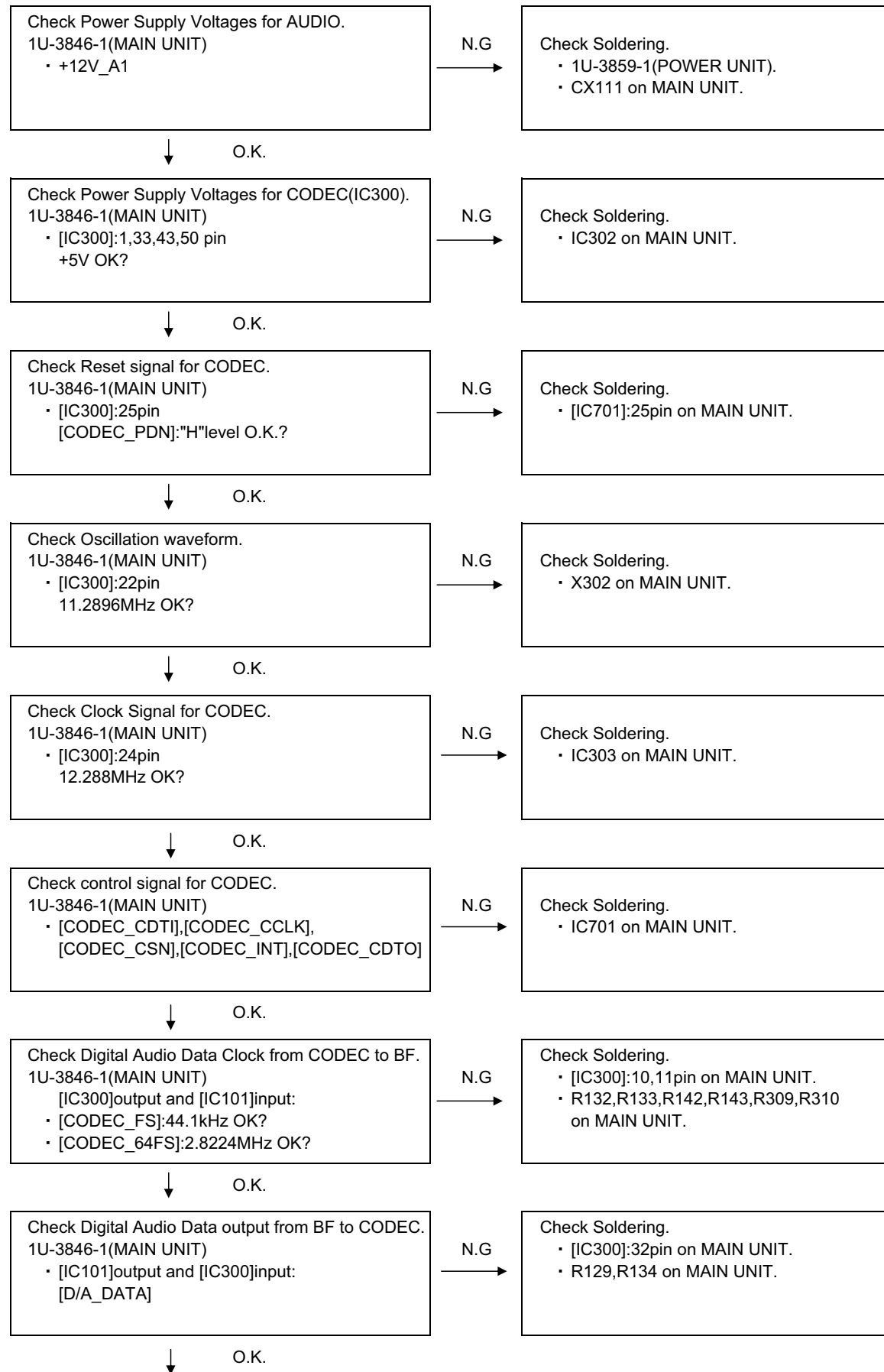

3. 音声出力せず、ノイズ発生

(1) CD 再生時(S-52,S-52DABのみ)

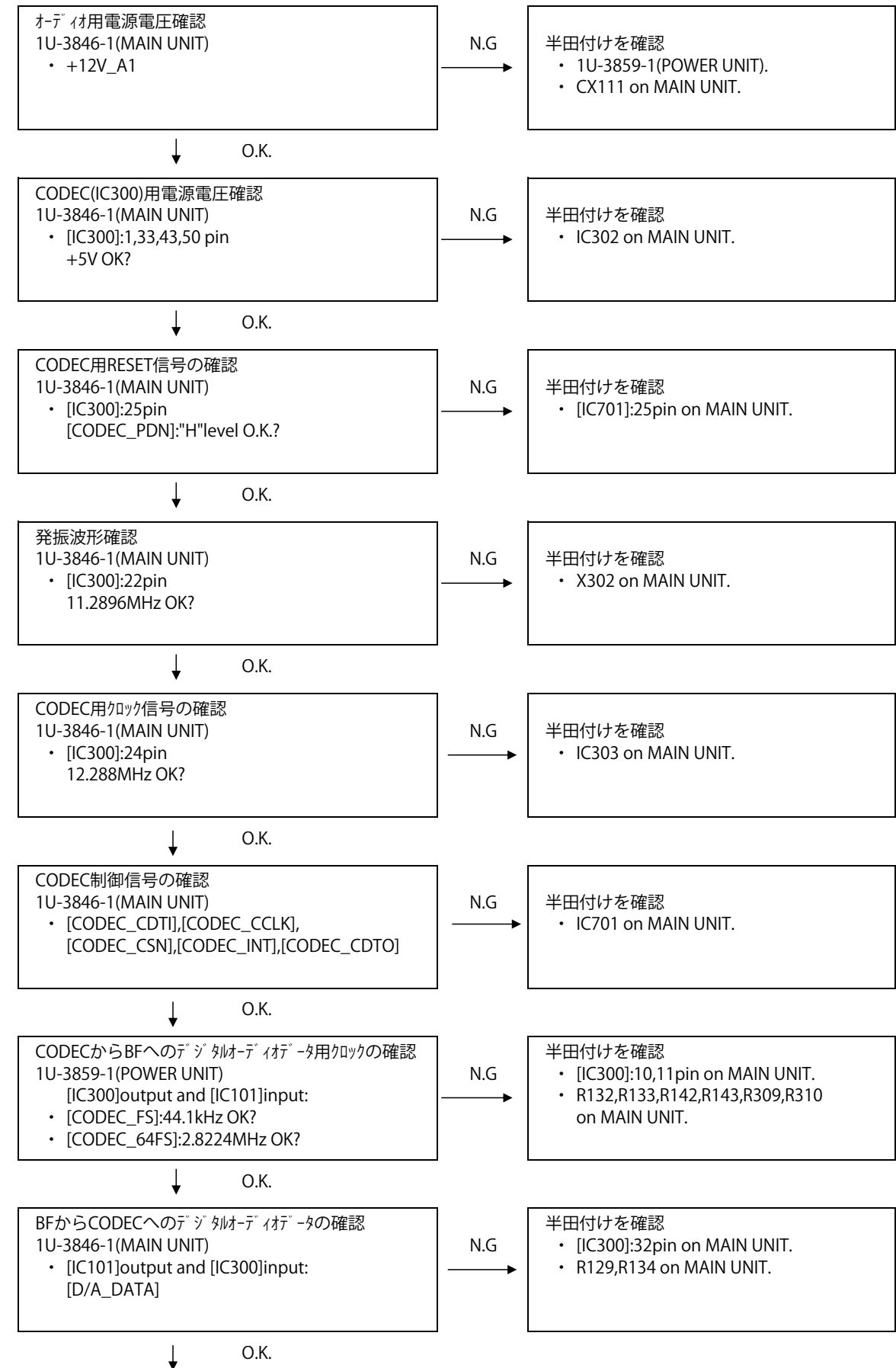

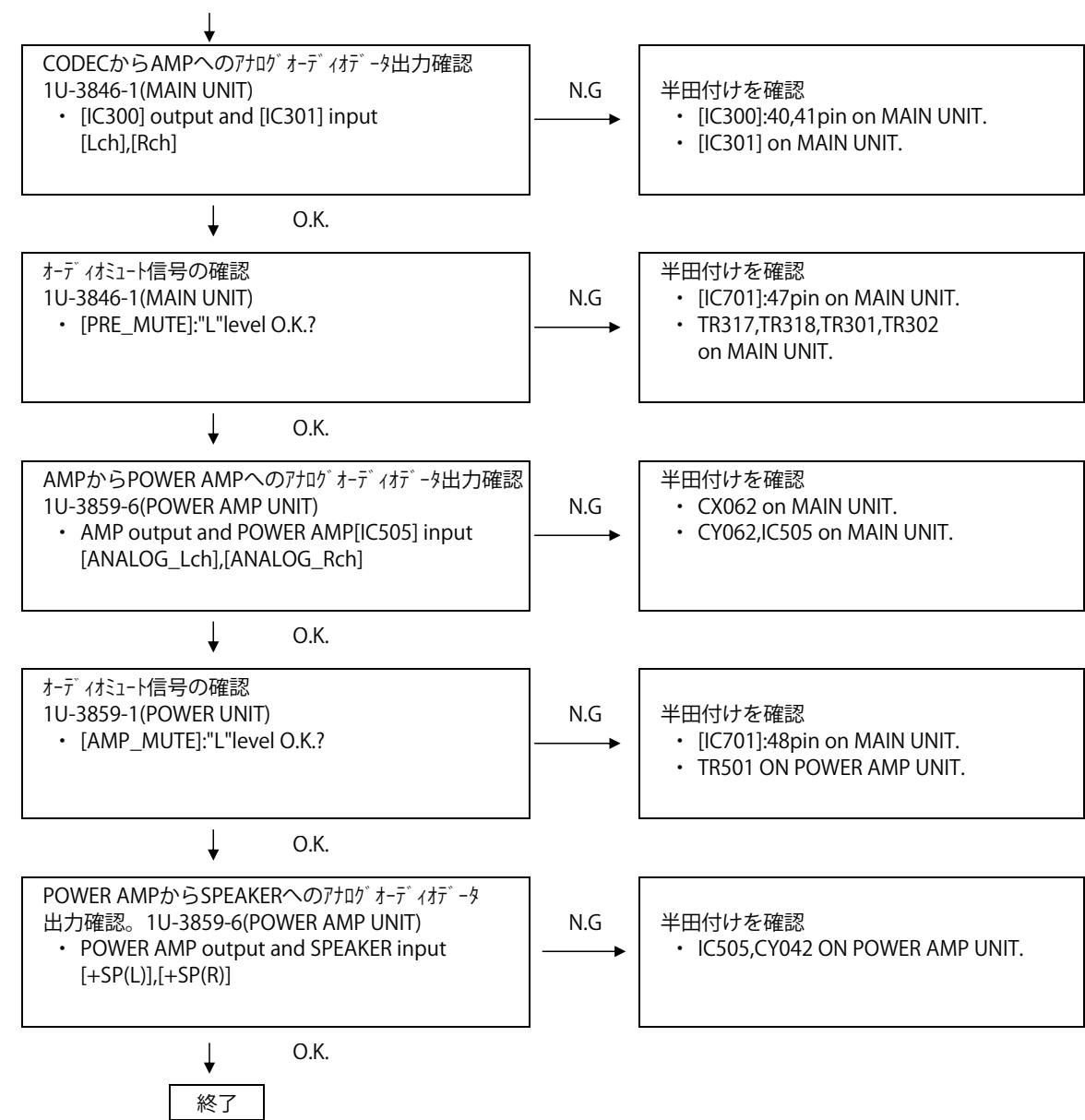
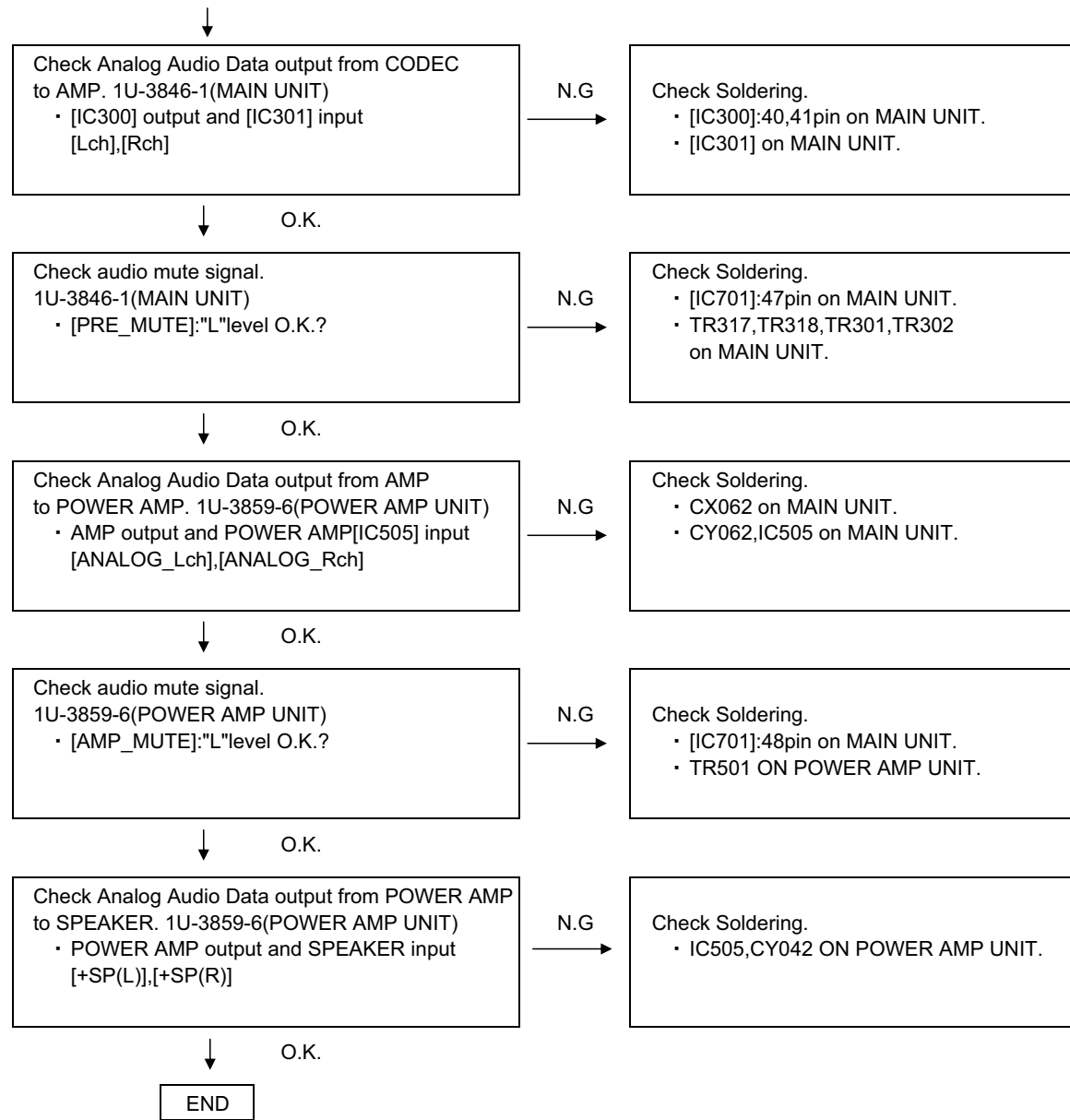

(2) AM/FM TUNER-in(S-52E2JP,S-52DAB,S-32 only)

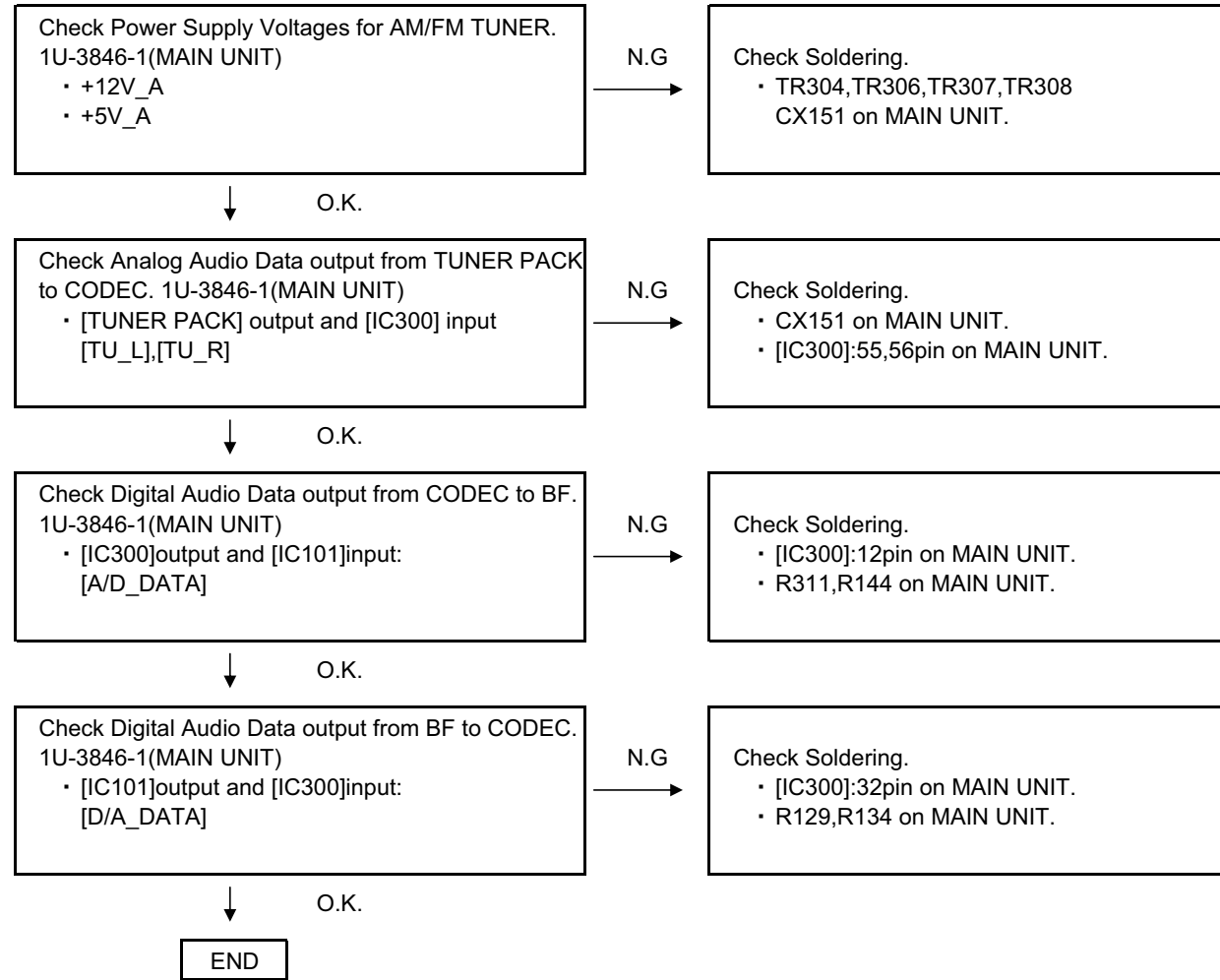

(3) Portable-in(Front-in)

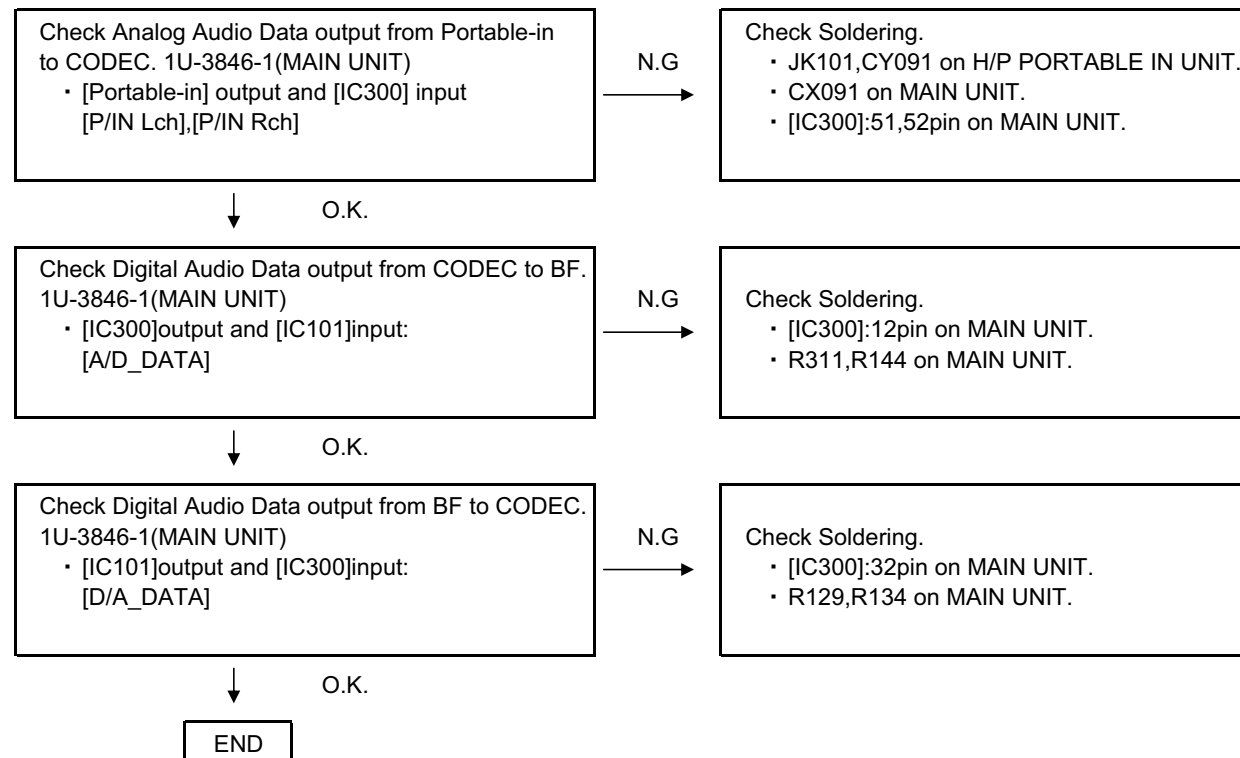

(2) AM/FM TUNER入力(S-52E2JP,S-52DAB,S-32のみ)

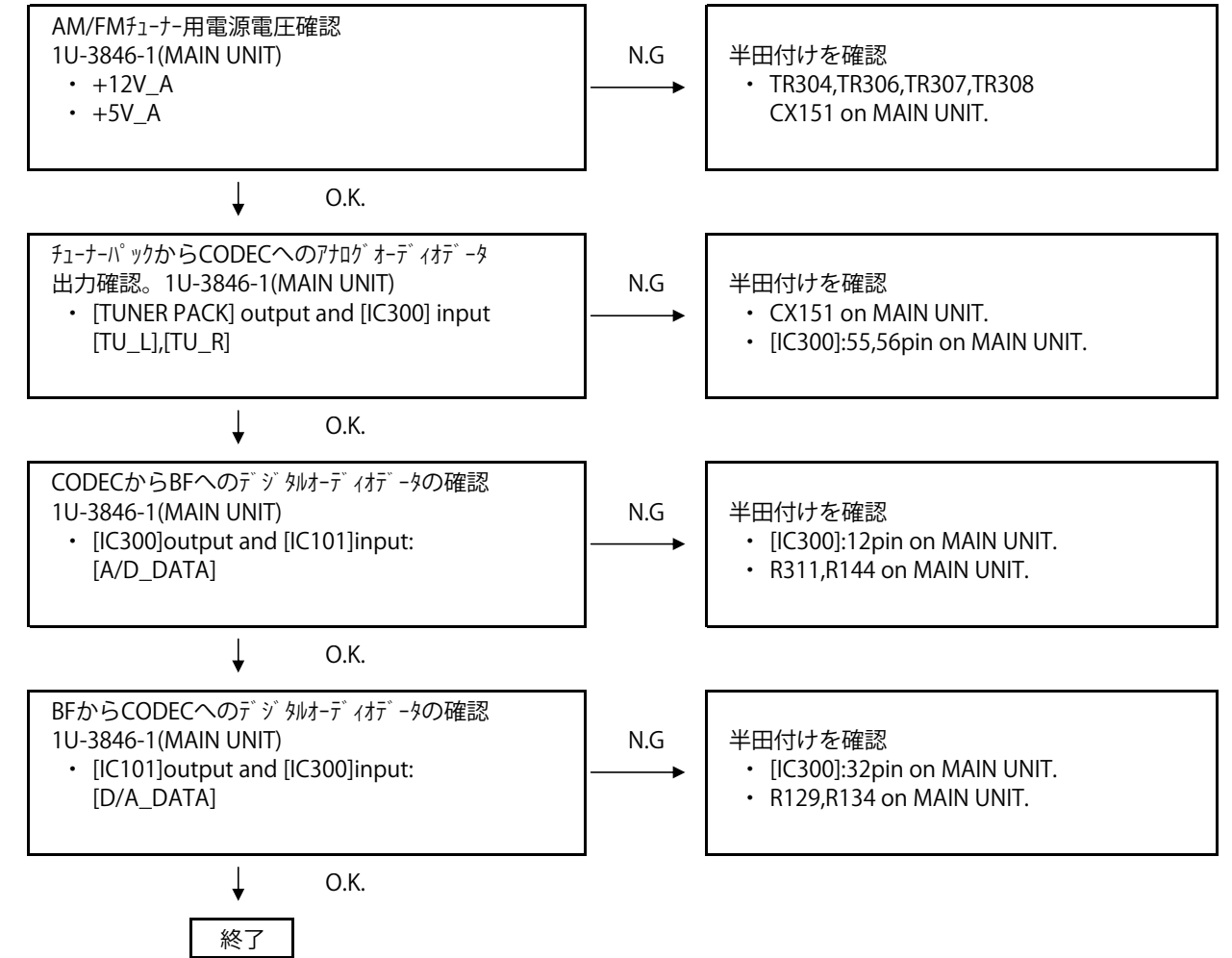

(3) Portable入力(Front入力)

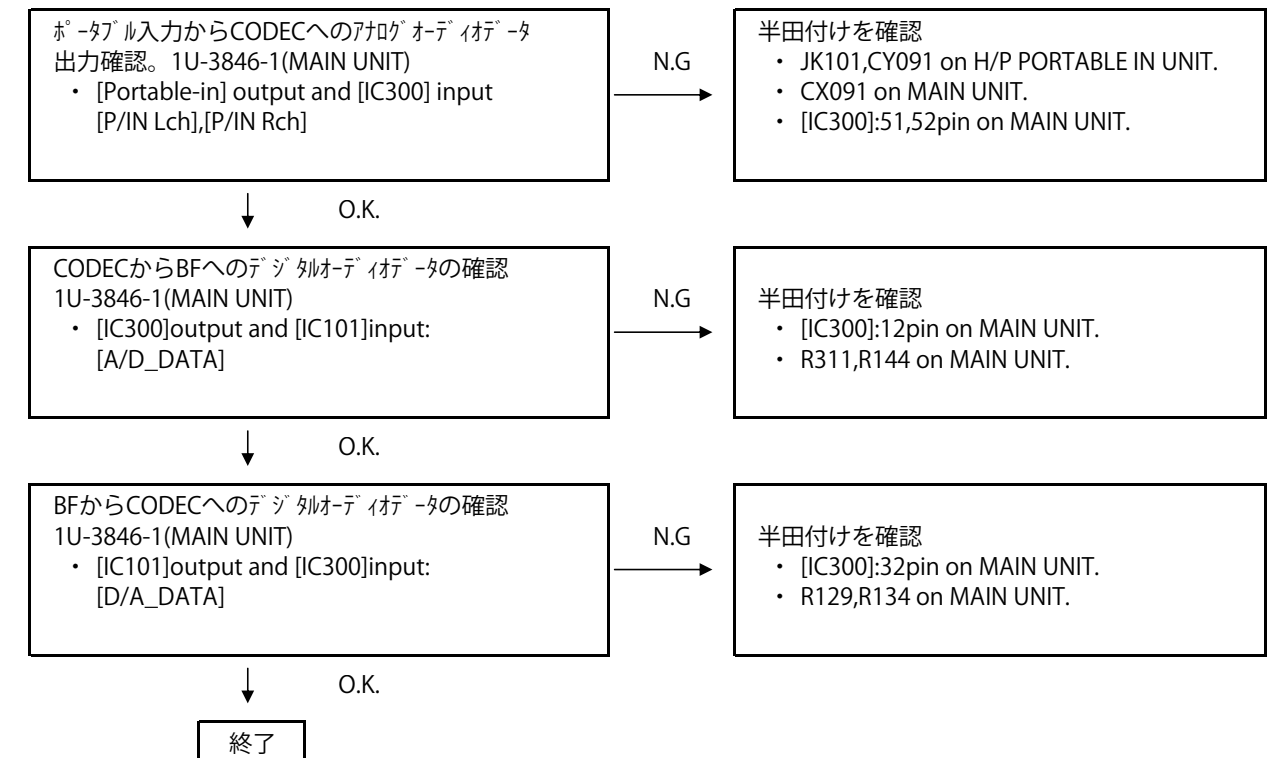

(4) IPOD-IN

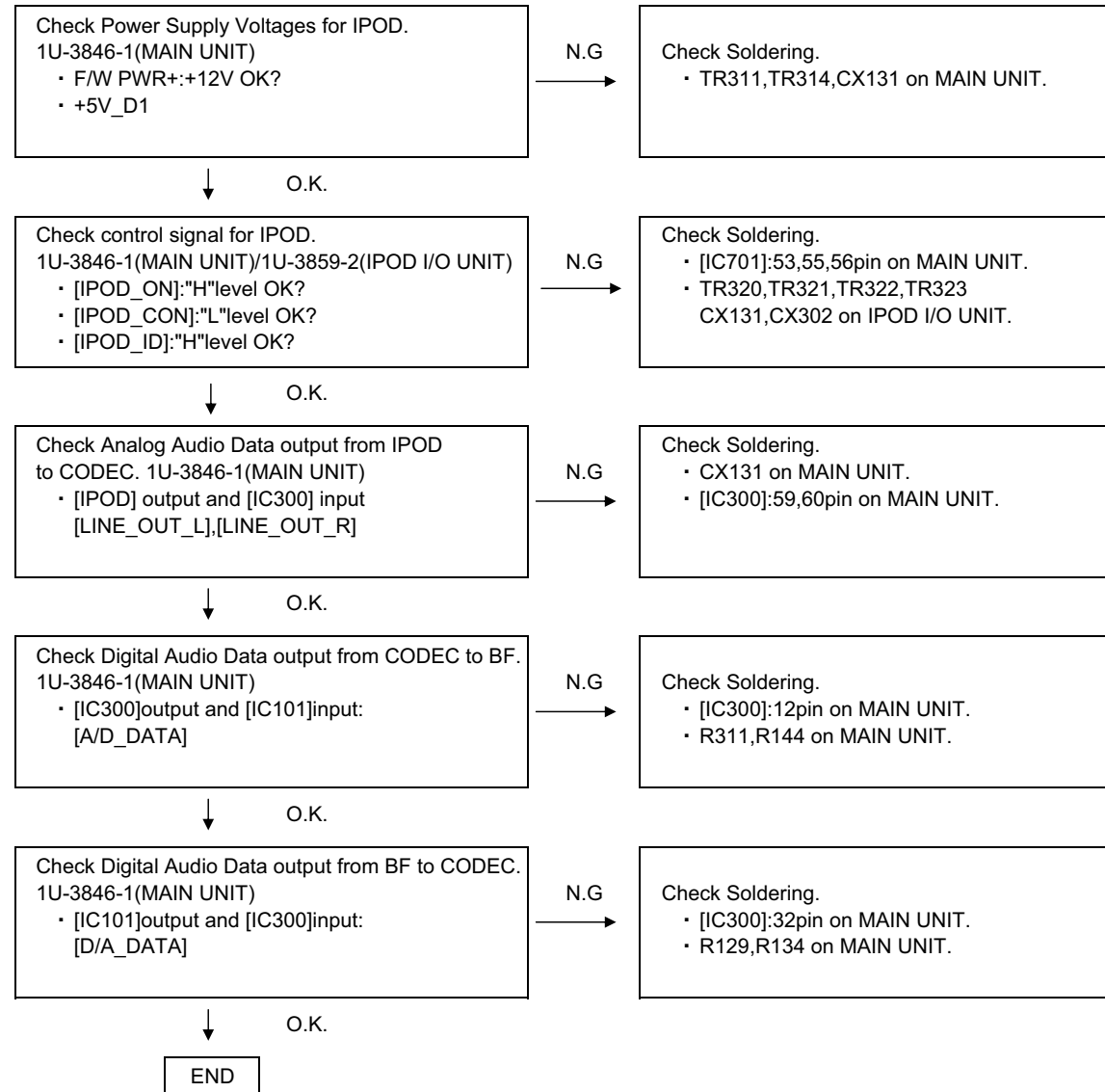

(5) HD RADIO-in(S-52E3 only)

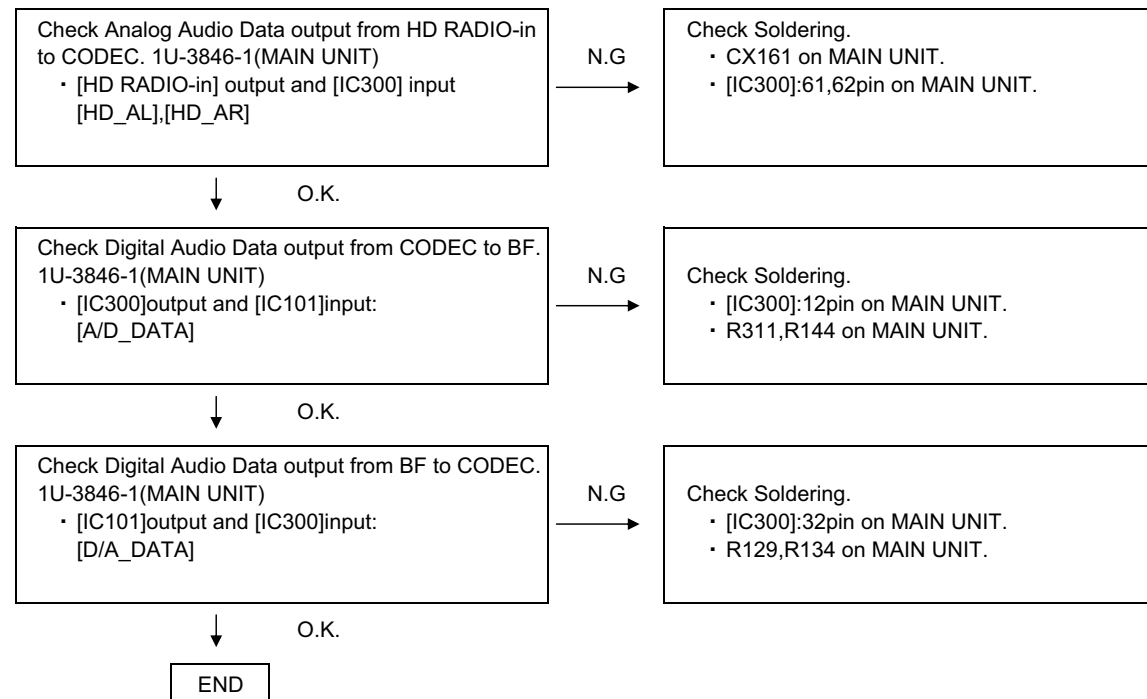

(4) IPOD入力

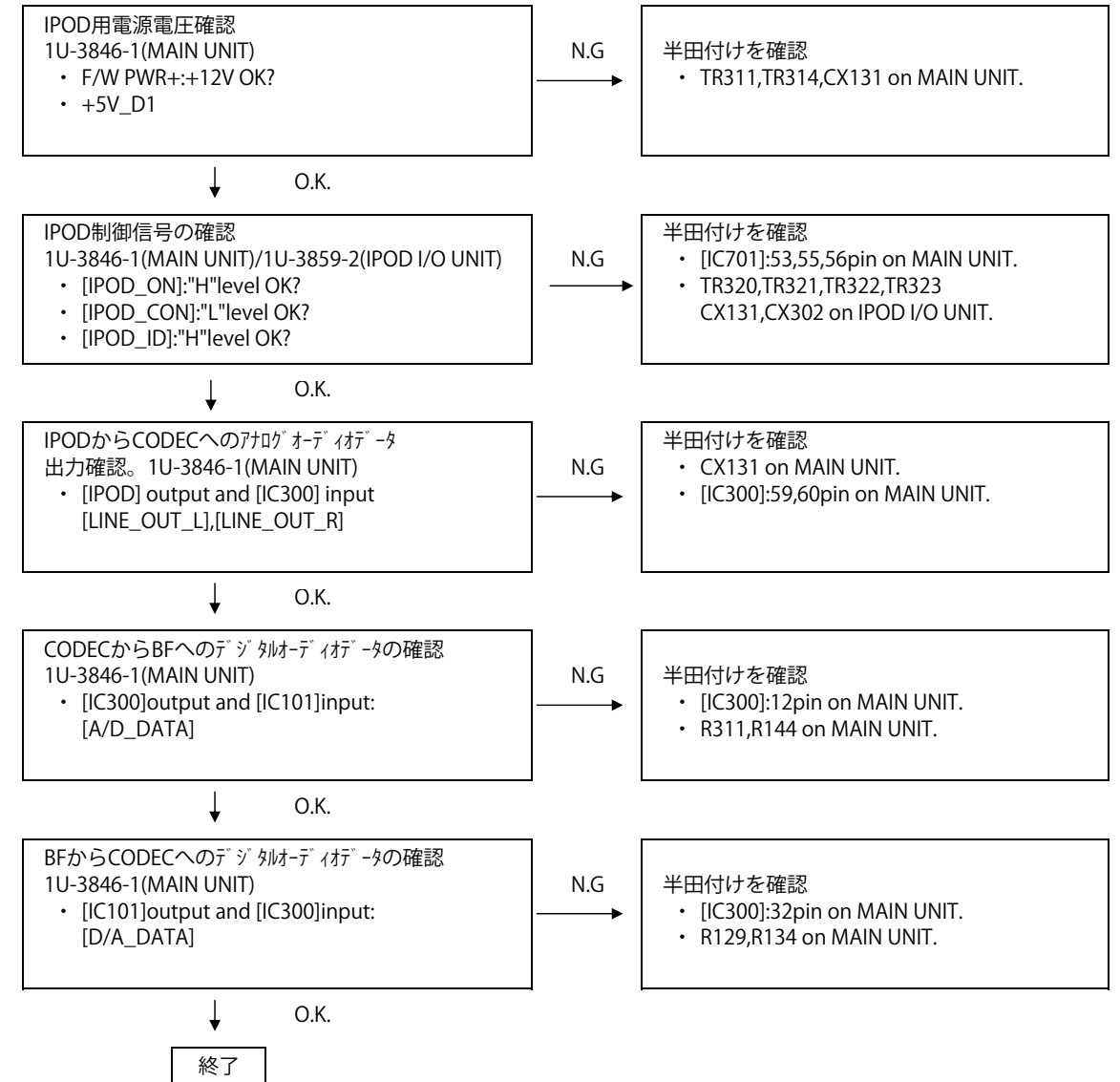

(5) HD RADIO入力(S-52E3のみ)

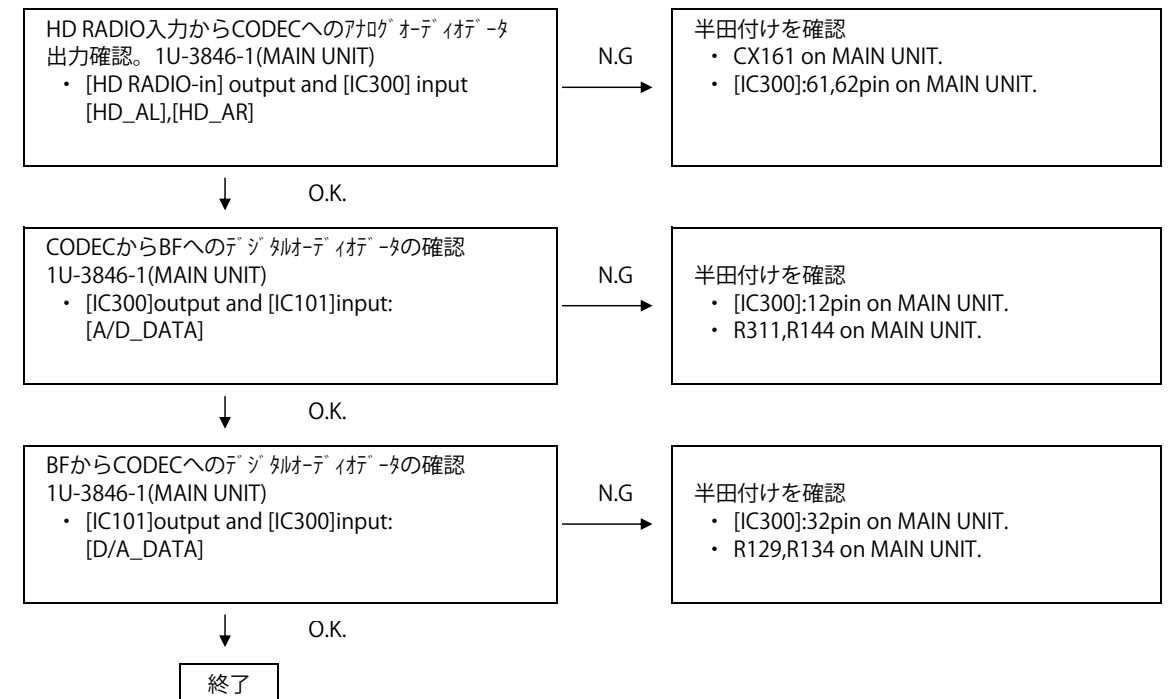

(6) XM RADIO-in(S-52E3 only)

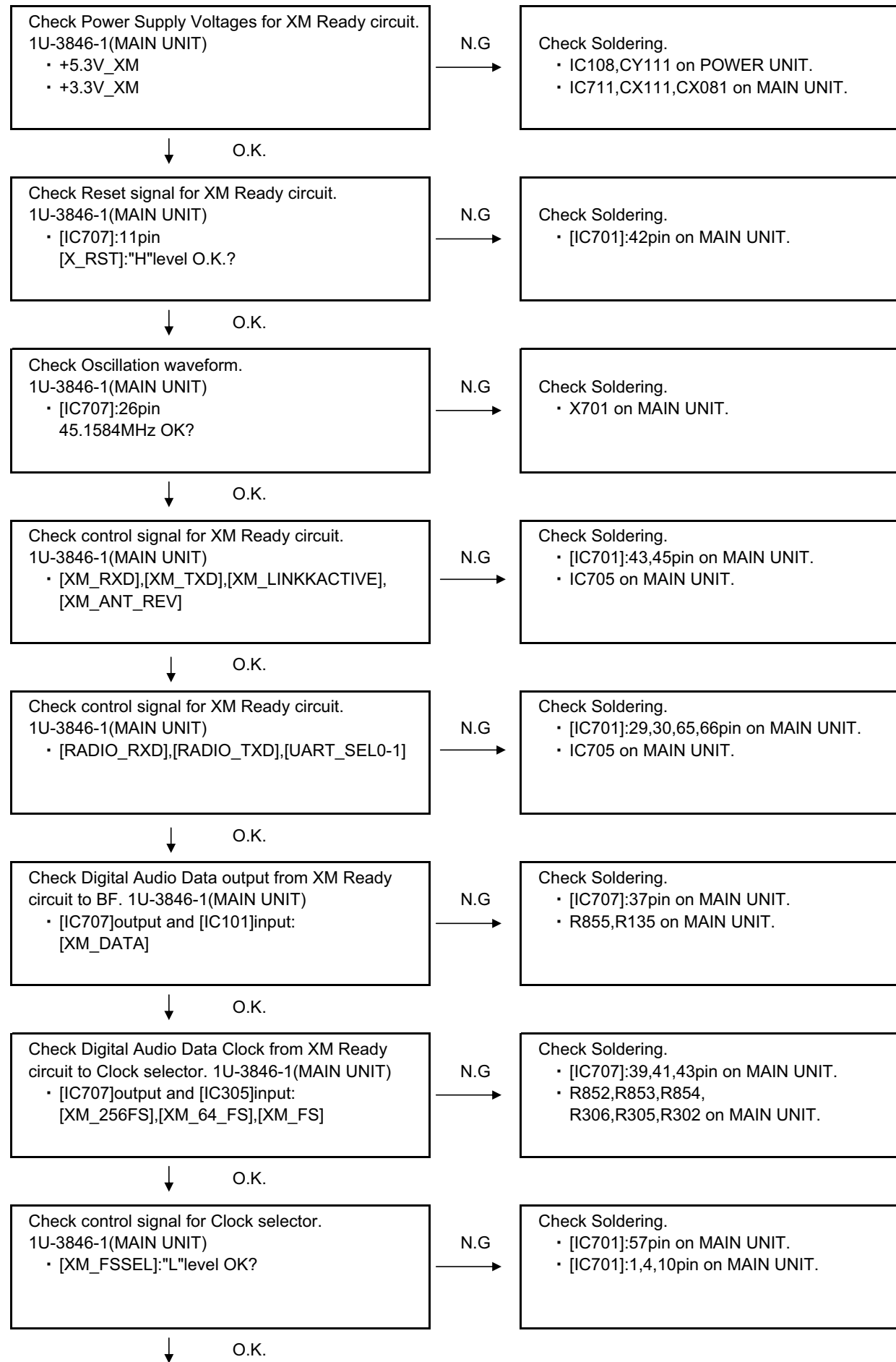

(6) XM RADIO入力(S-52E3のみ)

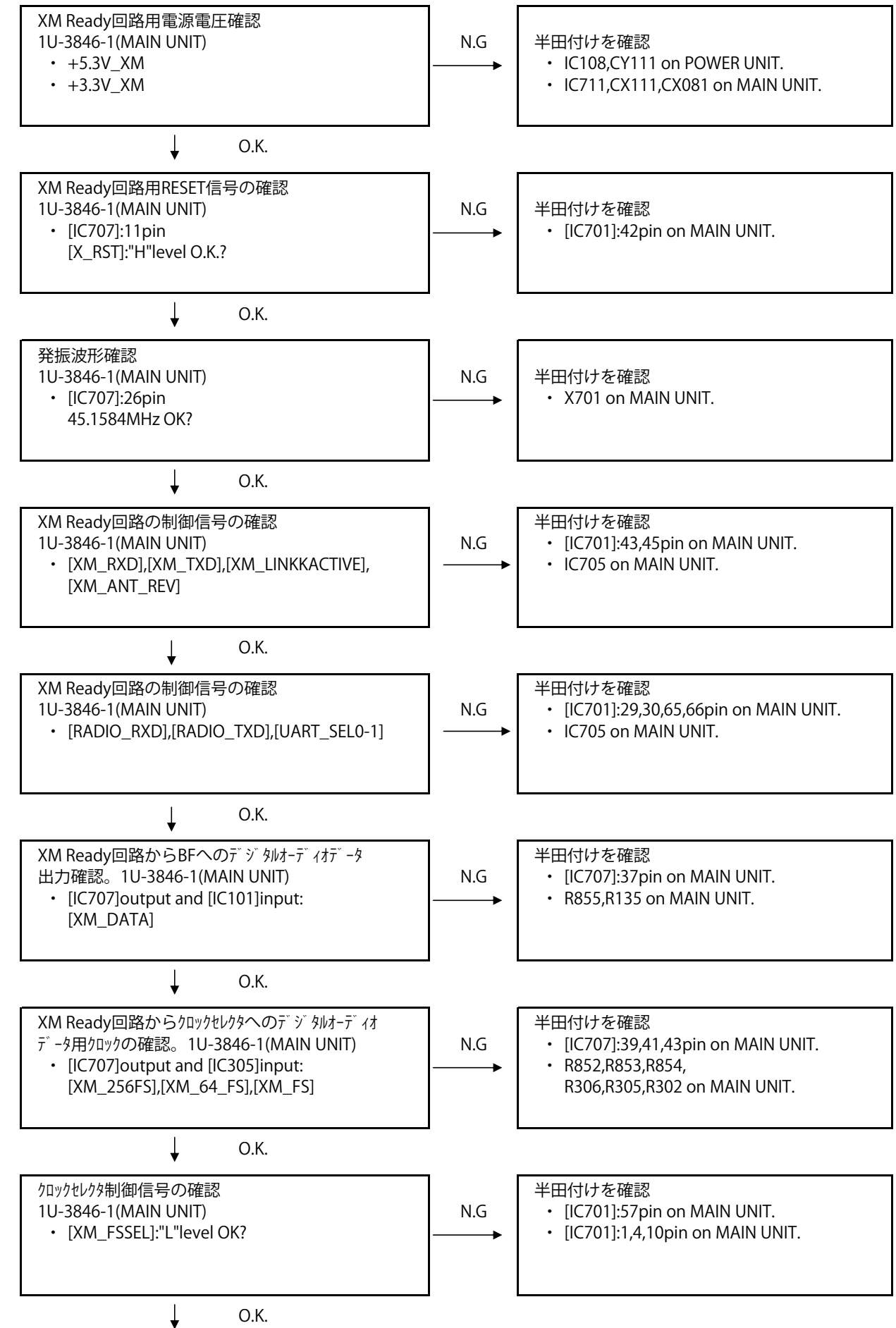

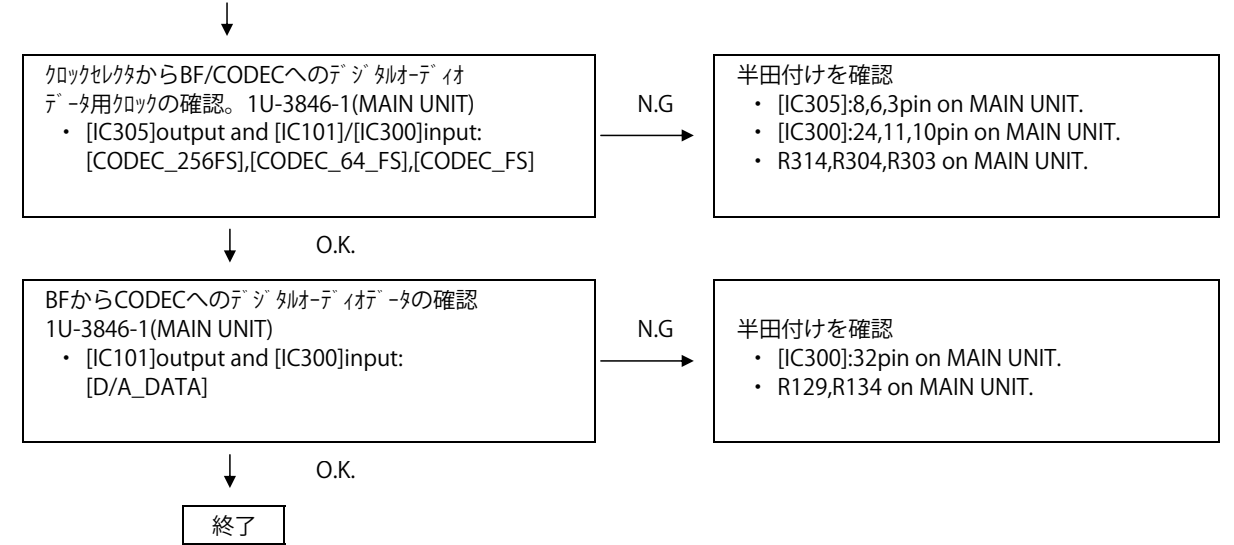
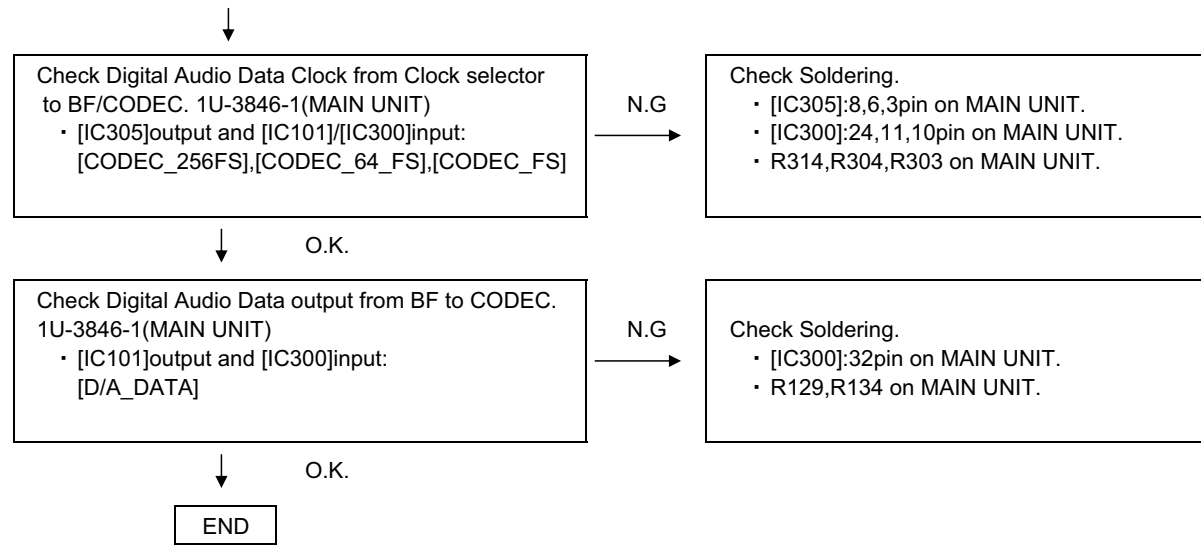

(7) DAB TUNER-in(S-52DAB only)

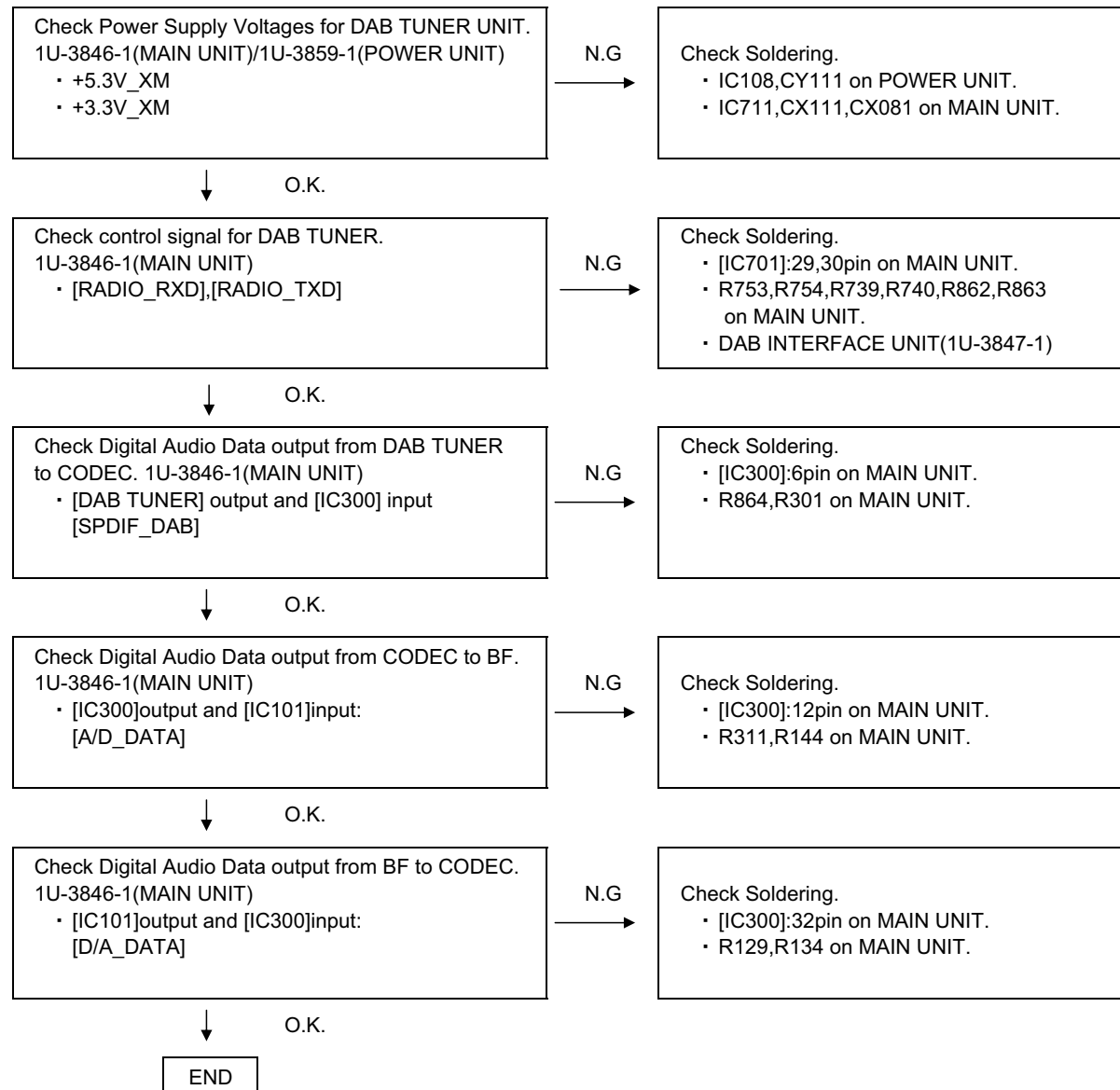

(7) DAB TUNER入力(S-52DABのみ)

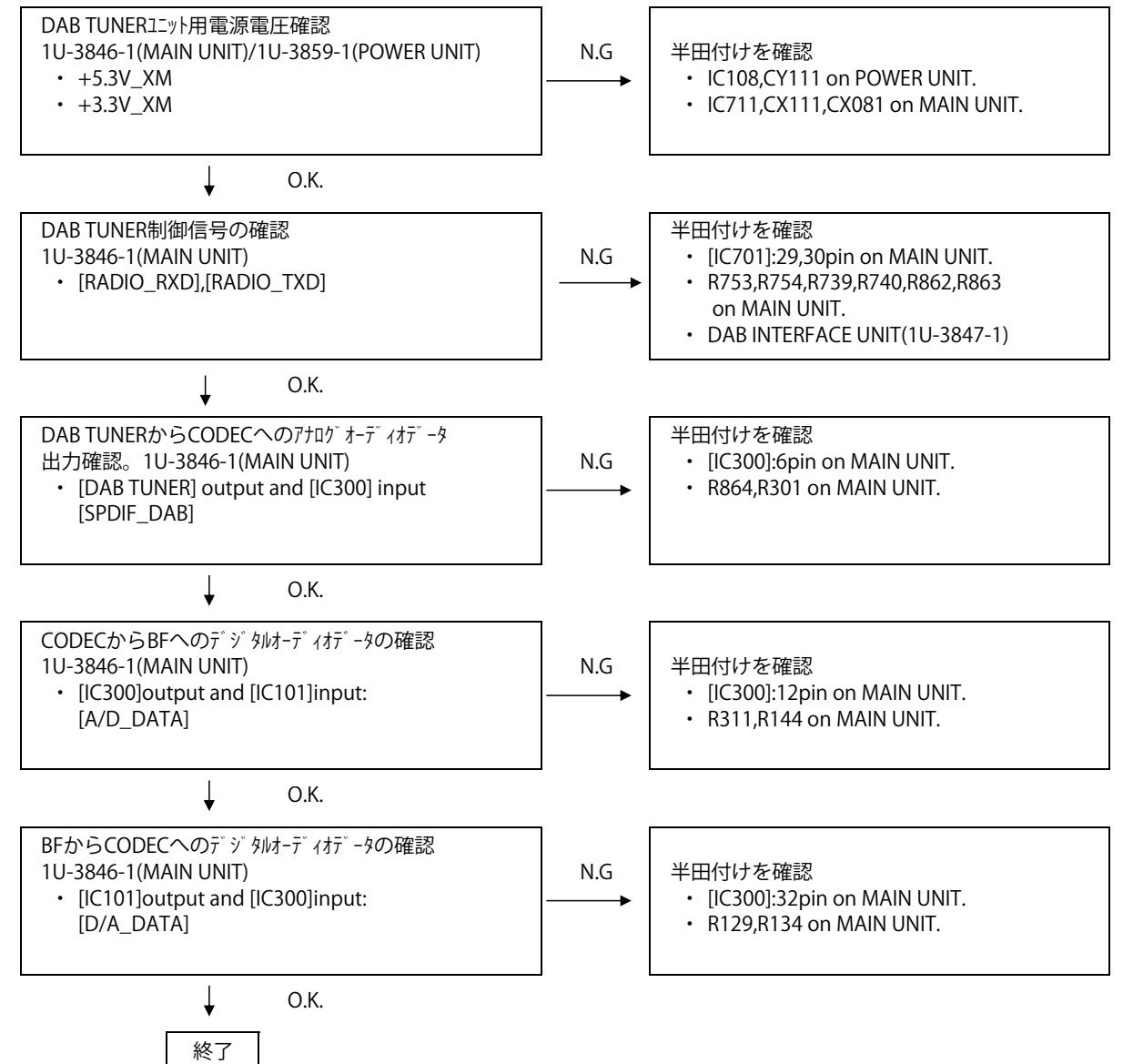

(8) ETHERNET-in

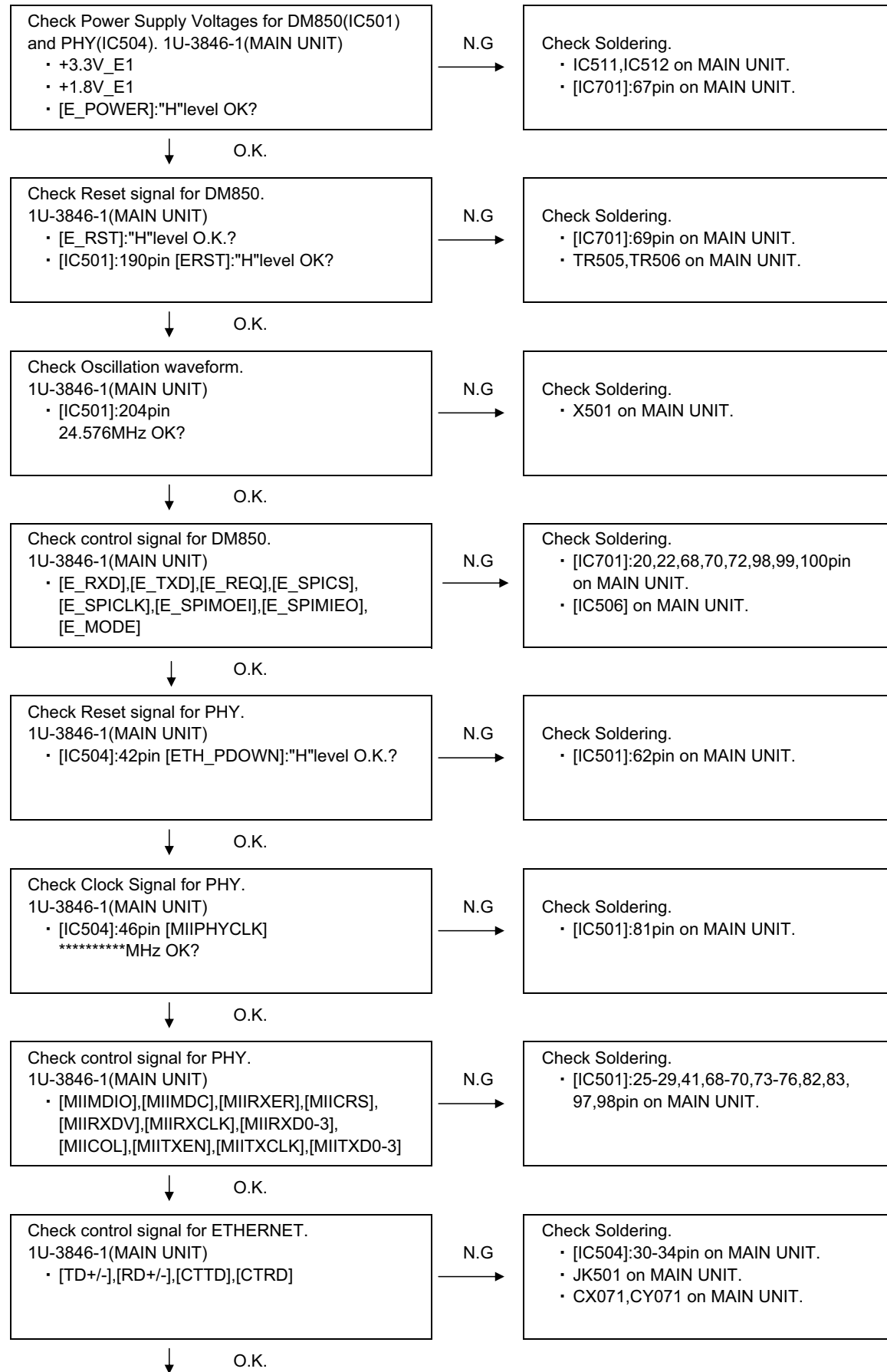

(8) ETHERNET入力

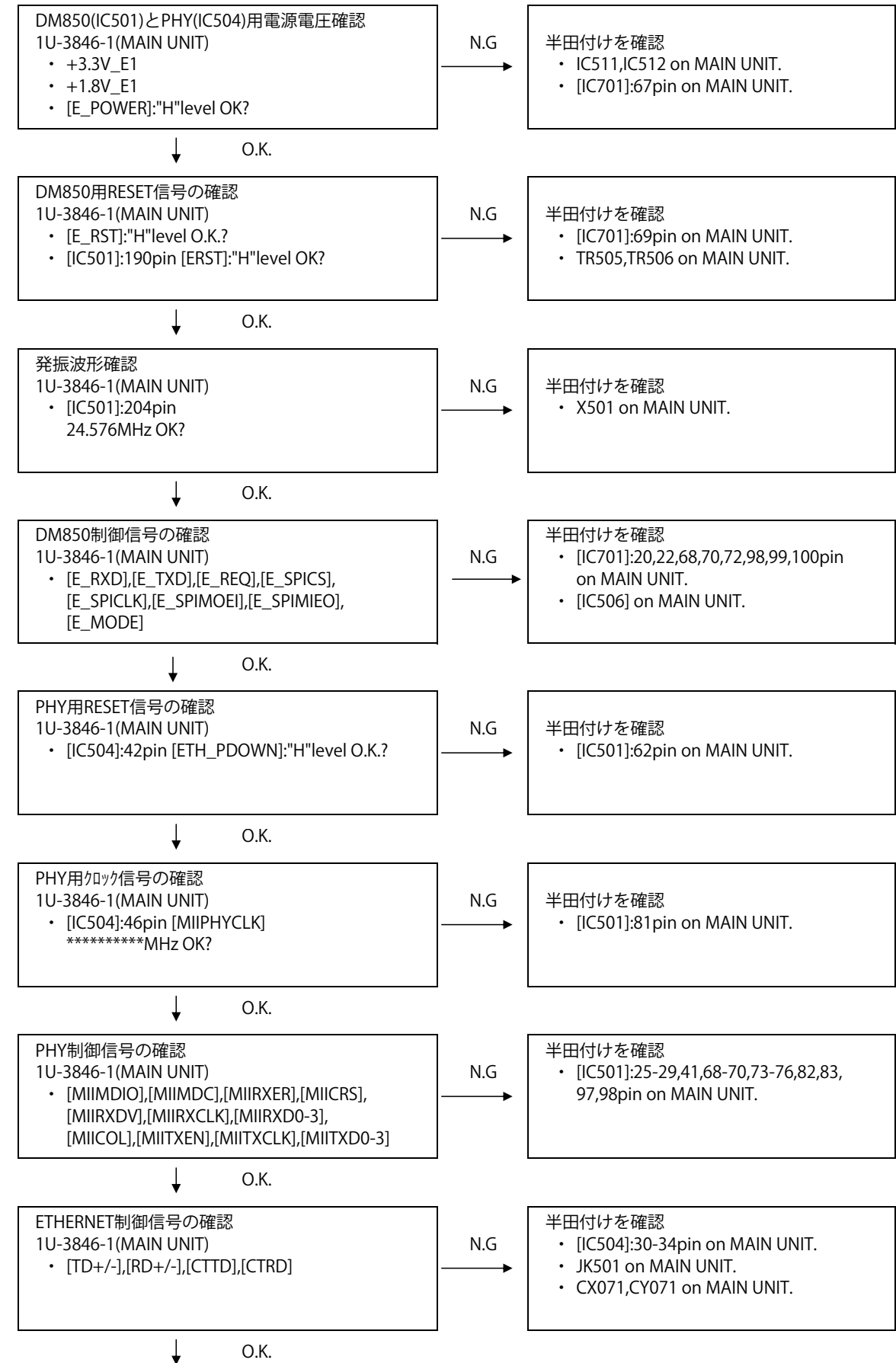

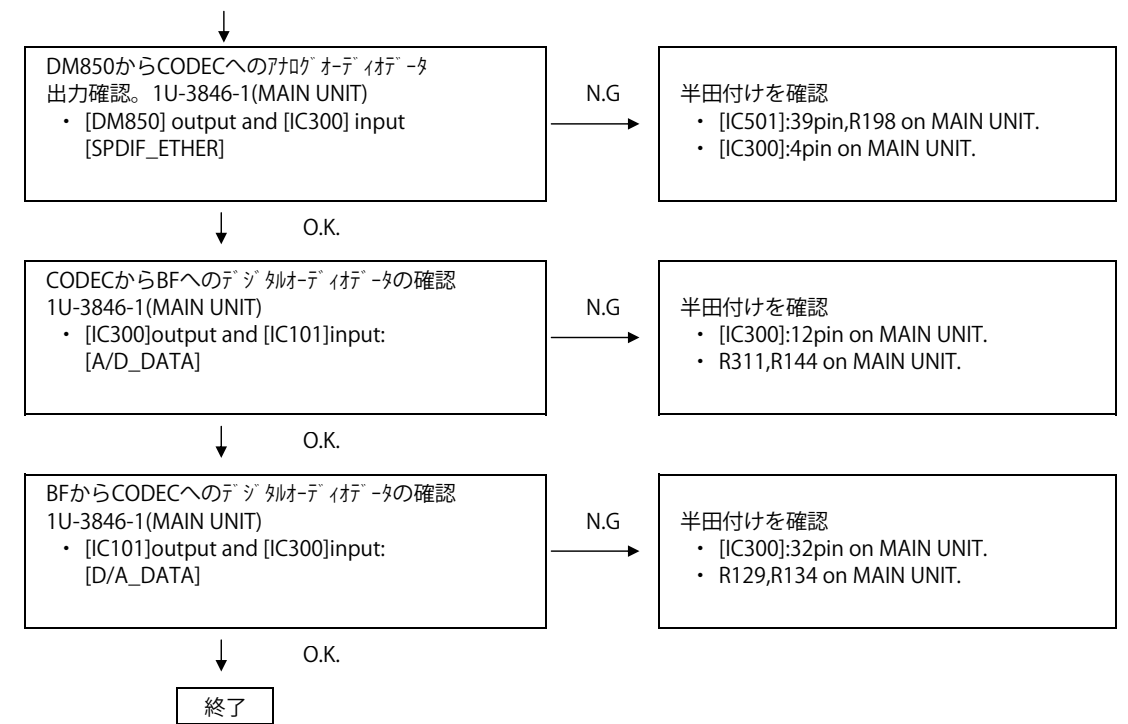
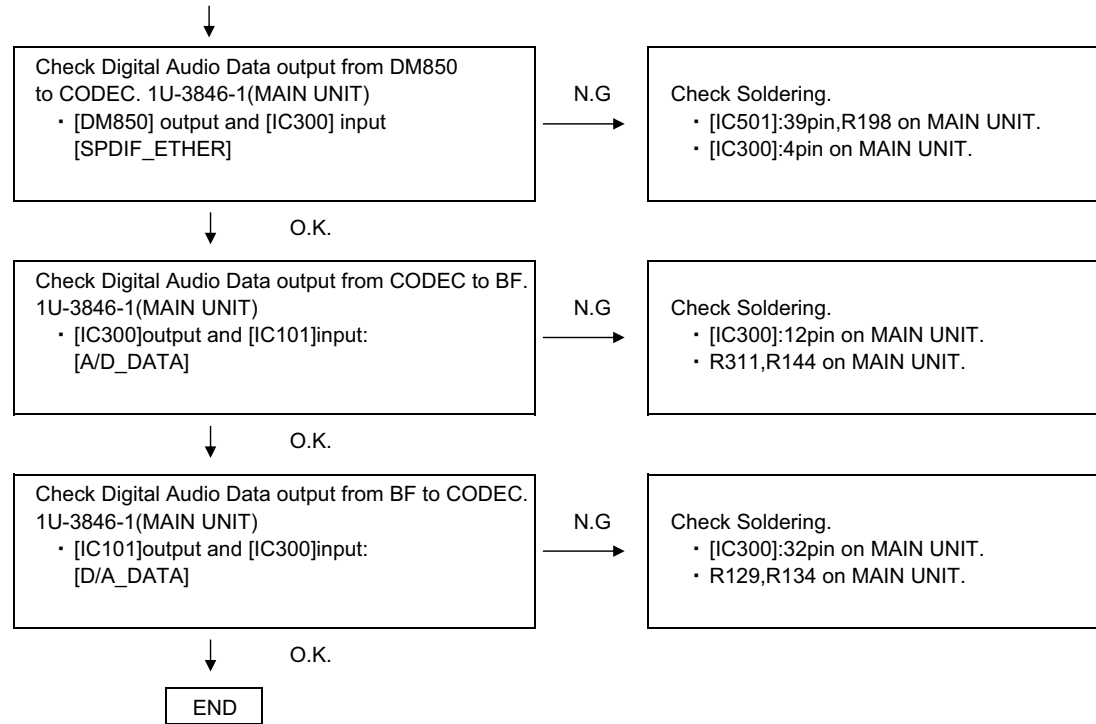

(9) USB-in

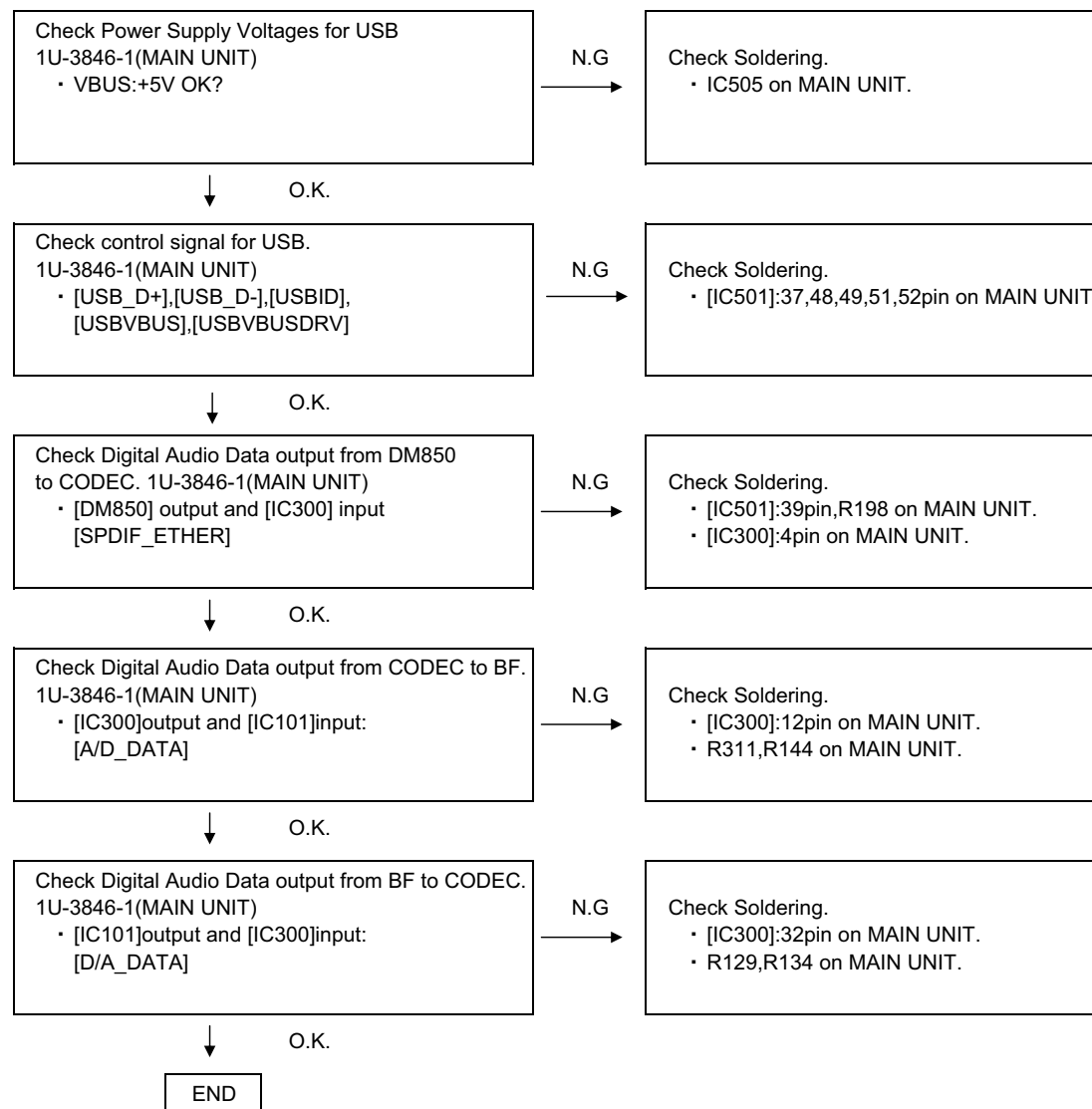

(9) USB入力

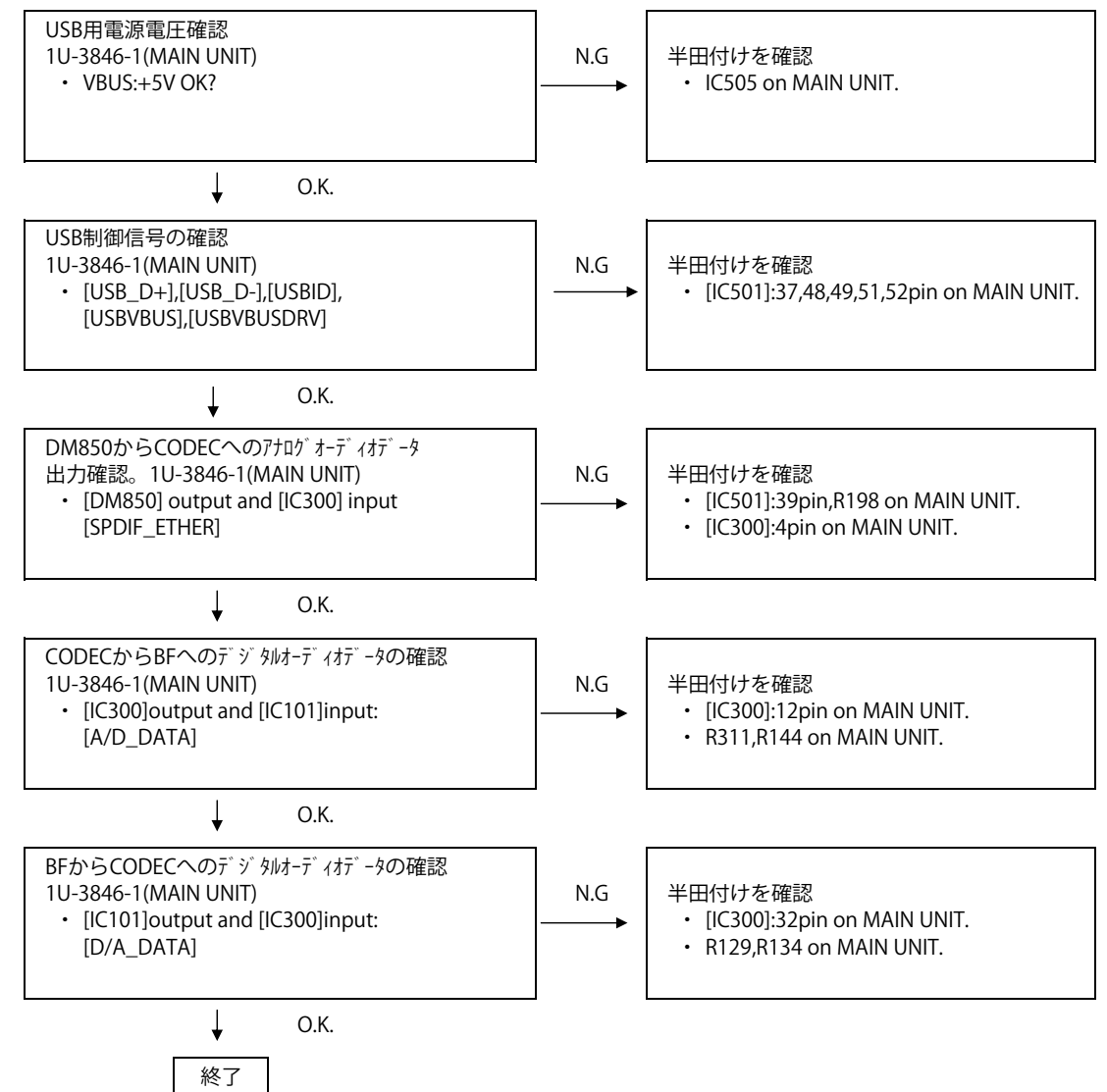

(10) WiFi-in

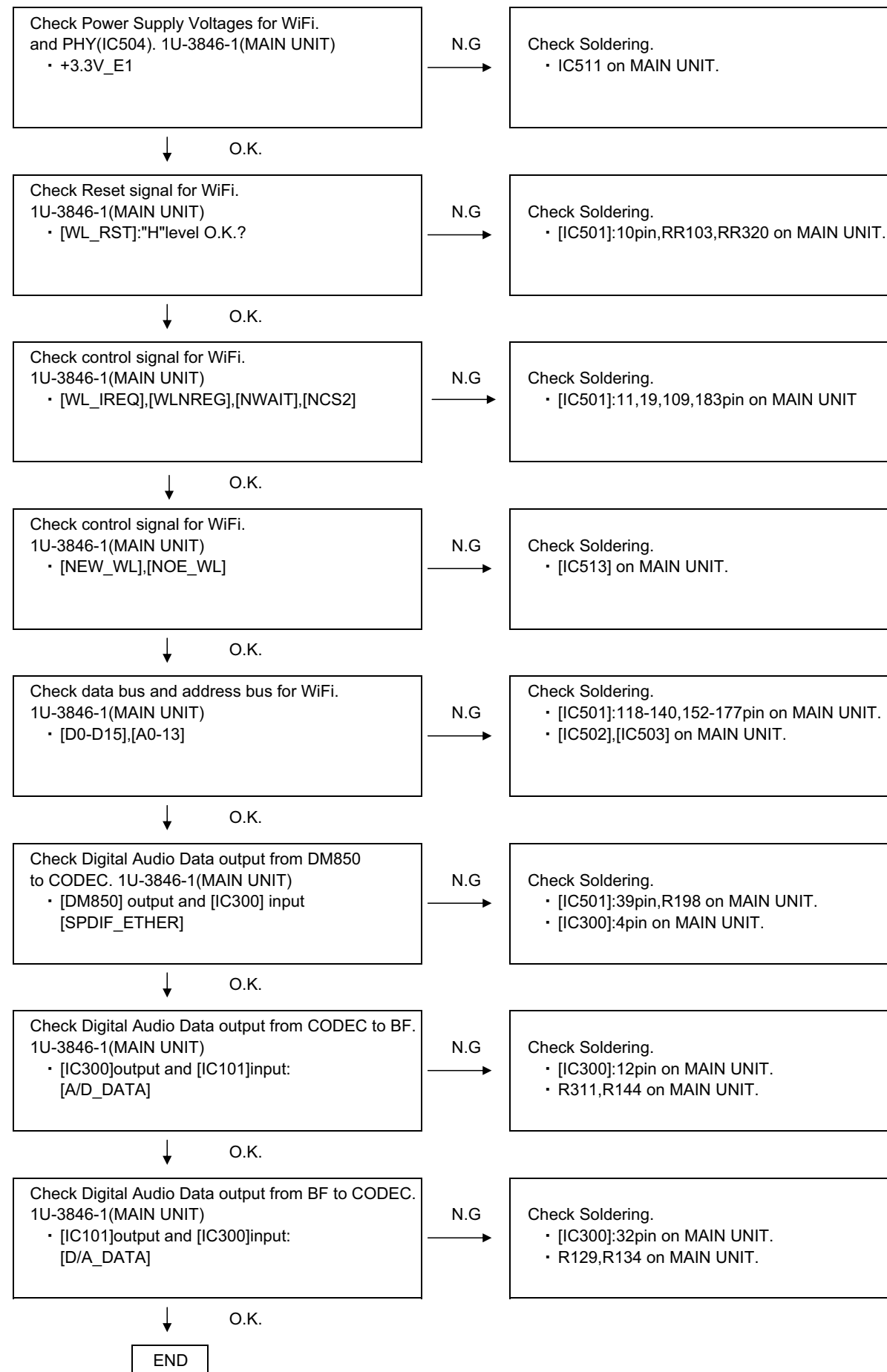

(10) WiFi入力

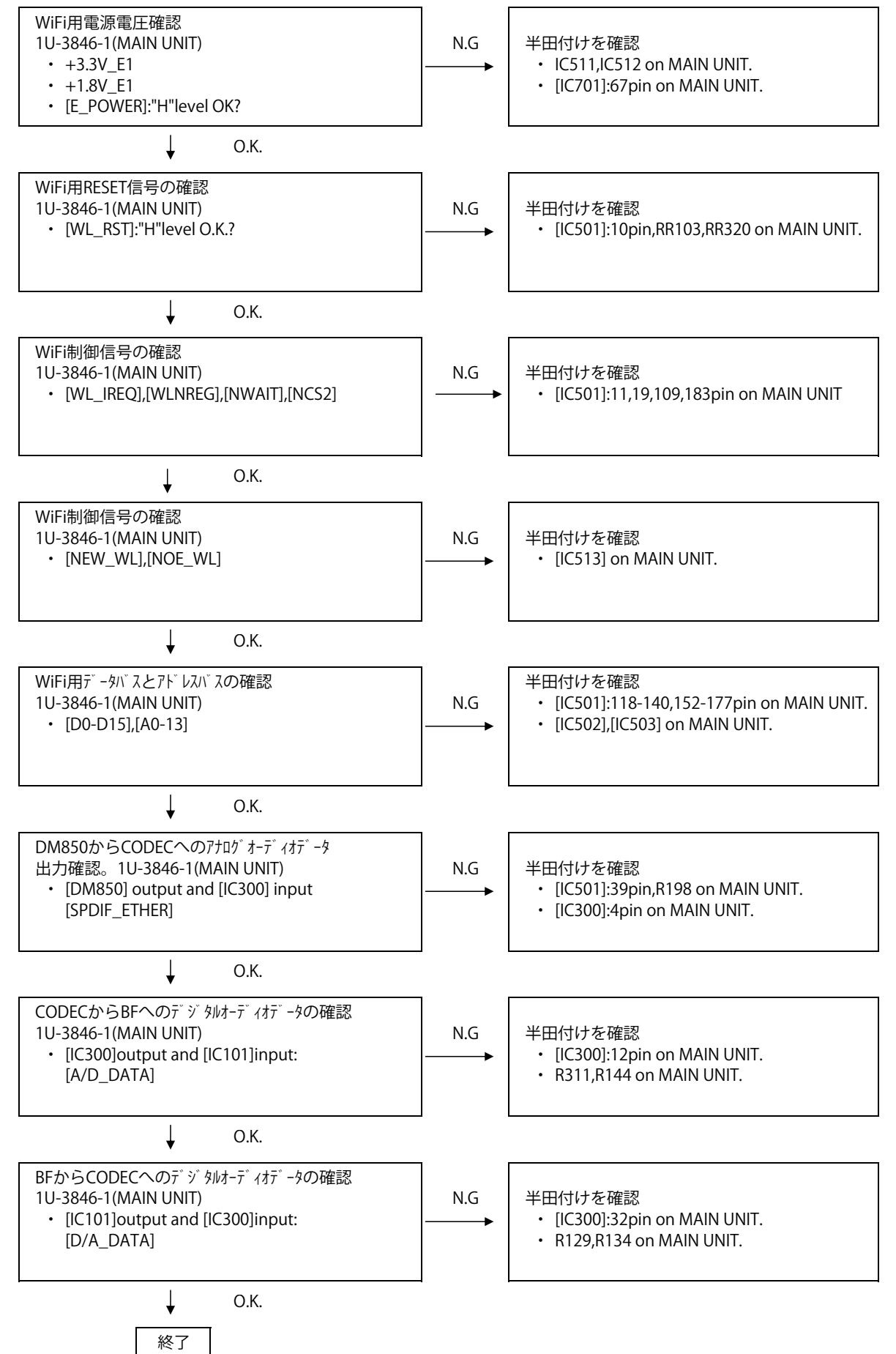

S52 SYSTEM PART BLOCK DIAGRAM

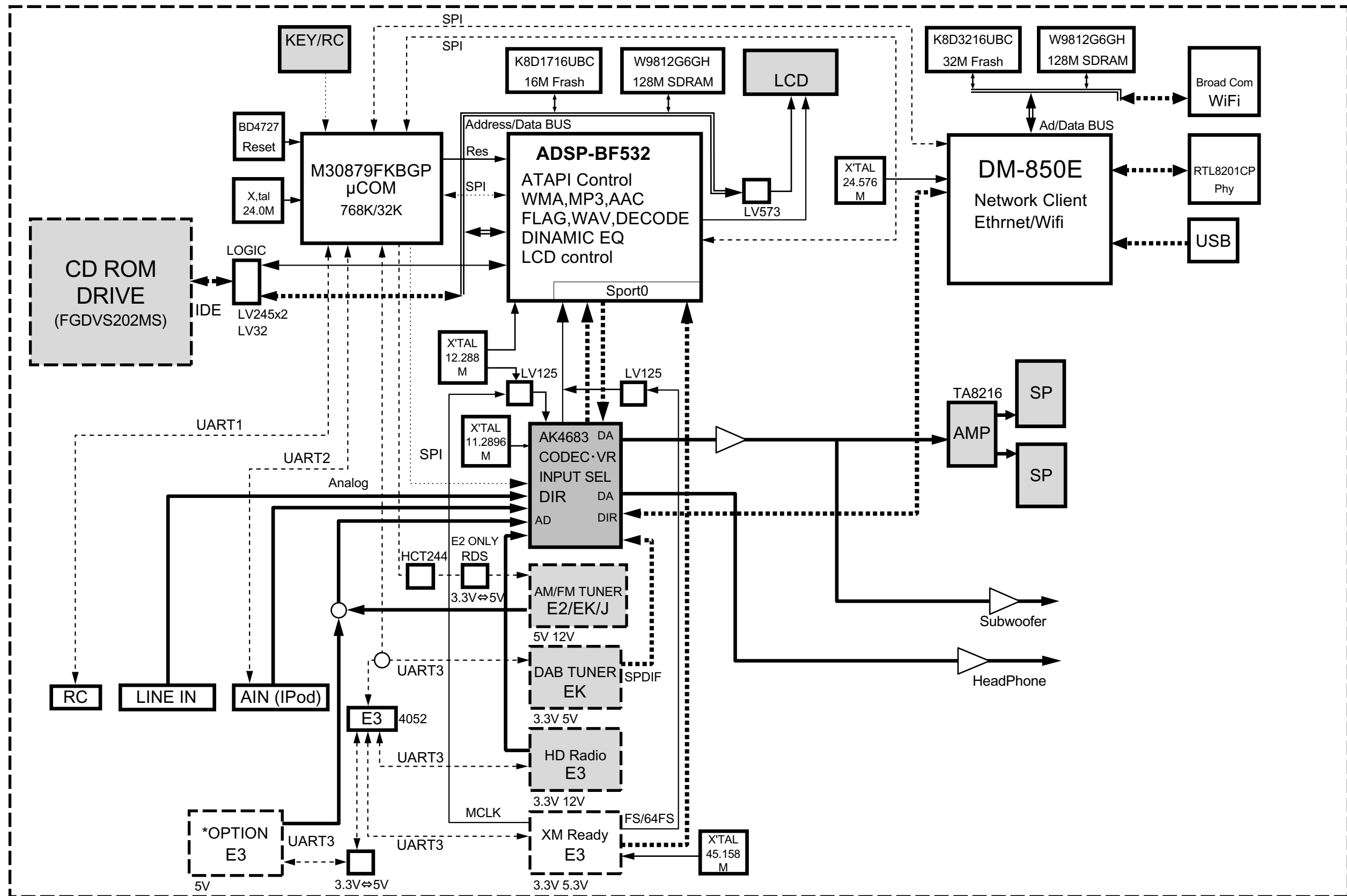

S32 SYSTEM PART BLOCK DIAGRAM

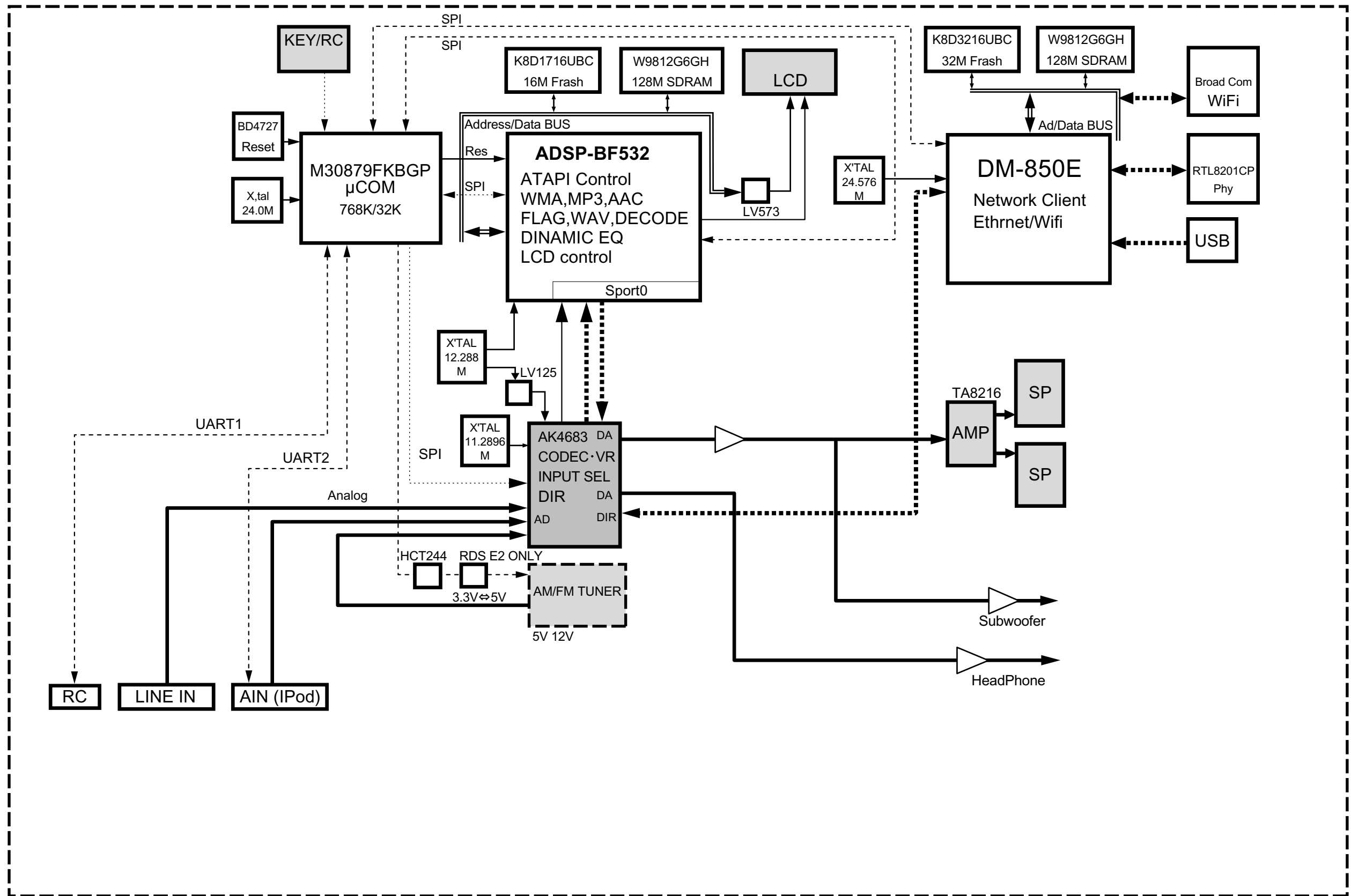

LEVEL DIAGRAM

DENON S52/ S32 LEVEL DIAGRAM

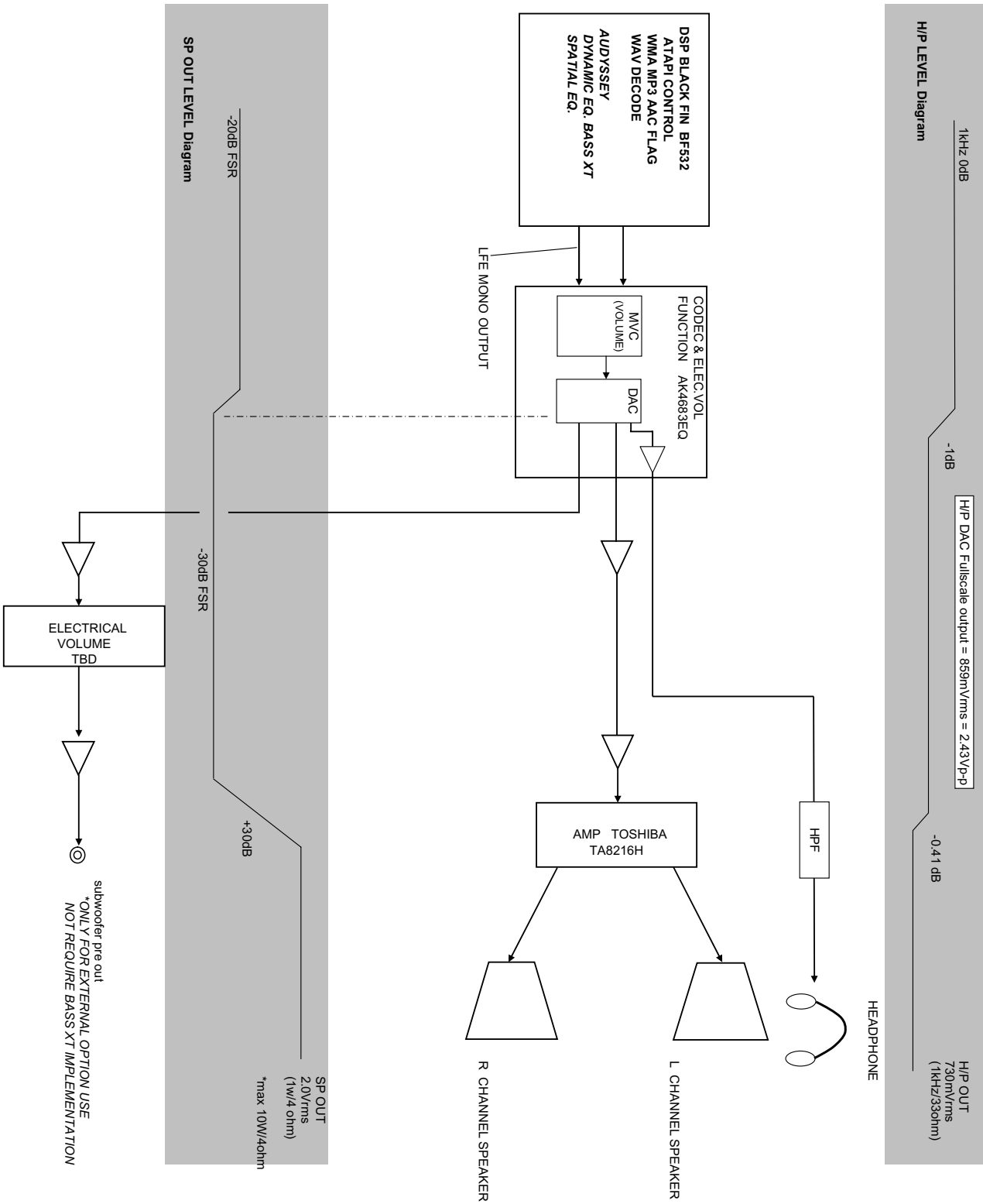

SEMICONDUCTORS

Only major semiconductors are shown, general semiconductors etc. are omitted to list.
 主な半導体を記載しています。汎用の半導体は記載を省略しています。

1. IC's

DM850E (IC502)

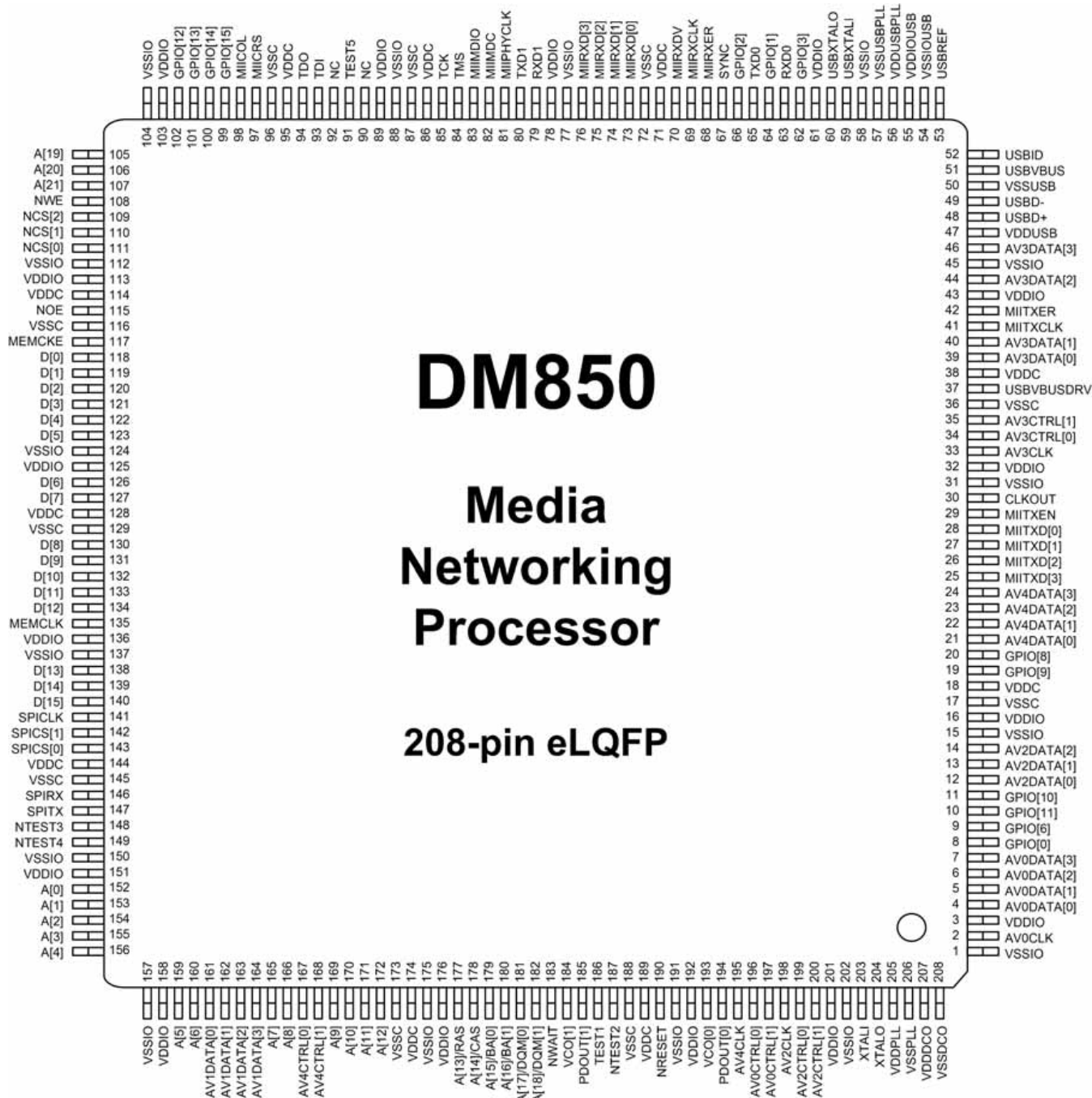

DM850
Media
Networking
Processor
208-pin eLQFP

DM850E Pin Assignment by Pin Number

| Pin | Name | Pin | Name | Pin | Name | Pin | Name |
|-----|------------|-----|------------|-----|-----------|-----|--------------|
| 1 | VSSIO | 53 | USBREF | 105 | A[19] | 157 | VSSIO |
| 2 | AV0CLK | 54 | VSSIOUSB | 106 | A[20] | 158 | VDDIO |
| 3 | VDDIO | 55 | VDDIOUSB | 107 | A[21] | 159 | A[5] |
| 4 | AV0DATA[0] | 56 | VDDUSBPLL | 108 | NWE | 160 | A[6] |
| 5 | AV0DATA[1] | 57 | VSSUSBPLL | 109 | NCS[2] | 161 | AV1DATA[0] |
| 6 | AV0DATA[2] | 58 | VSSIO | 110 | NCS[1] | 162 | AV1DATA[1] |
| 7 | AV0DATA[3] | 59 | USBXTALI | 111 | NCS[0] | 163 | AV1DATA[2] |
| 8 | GPIO[0] | 60 | USBXTALO | 112 | VSSIO | 164 | AV1DATA[3] |
| 9 | GPIO[6] | 61 | VDDIO | 113 | VDDIO | 165 | A[7] |
| 10 | GPIO[11] | 62 | GPIO[3] | 114 | VDDC | 166 | A[8] |
| 11 | GPIO[10] | 63 | RXD0 | 115 | NOE | 167 | AV4CTRL[0] |
| 12 | AV2DATA[0] | 64 | GPIO[1] | 116 | VSSC | 168 | AV4CTRL[1] |
| 13 | AV2DATA[1] | 65 | TXD0 | 117 | MEMCKE | 169 | A[9] |
| 14 | AV2DATA[2] | 66 | GPIO[2] | 118 | D[0] | 170 | A[10] |
| 15 | VSSIO | 67 | SYNC | 119 | D[1] | 171 | A[11] |
| 16 | VDDIO | 68 | MIIRXER | 120 | D[2] | 172 | A[12] |
| 17 | VSSC | 69 | MIIRXCLK | 121 | D[3] | 173 | VSSC |
| 18 | VDDC | 70 | MIIRXDV | 122 | D[4] | 174 | VDDC |
| 19 | GPIO[9] | 71 | VDDC | 123 | D[5] | 175 | VSSIO |
| 20 | GPIO[8] | 72 | VSSC | 124 | VSSIO | 176 | VDDIO |
| 21 | AV4DATA[0] | 73 | MIIRXD[0] | 125 | VDDIO | 177 | A[13]/RAS |
| 22 | AV4DATA[1] | 74 | MIIRXD[1] | 126 | D[6] | 178 | A[14]/CAS |
| 23 | AV4DATA[2] | 75 | MIIRXD[2] | 127 | D[7] | 179 | A[15]/BA[0] |
| 24 | AV4DATA[3] | 76 | MIIRXD[3] | 128 | VDDC | 180 | A[16]/BA[1] |
| 25 | MII TXD[3] | 77 | VSSIO | 129 | VSSC | 181 | A[17]/DQM[0] |
| 26 | MII TXD[2] | 78 | VDDIO | 130 | D[8] | 182 | A[18]/DQM[1] |
| 27 | MII TXD[1] | 79 | RXD1 | 131 | D[9] | 183 | NWAIT |
| 28 | MII TXD[0] | 80 | TXD1 | 132 | D[10] | 184 | VCO[1] |
| 29 | MII TXEN | 81 | MII PHYCLK | 133 | D[11] | 185 | PDOUT[1] |
| 30 | CLKOUT | 82 | MII DC | 134 | D[12] | 186 | TEST1 |
| 31 | VSSIO | 83 | MII DIO | 135 | MEMCLK | 187 | NTEST2 |
| 32 | VDDIO | 84 | TMS | 136 | VDDIO | 188 | VSSC |
| 33 | AV3CLK | 85 | TCK | 137 | VSSIO | 189 | VDDC |
| 34 | AV3CTRL[0] | 86 | VDDC | 138 | D[13] | 190 | NRESET |
| 35 | AV3CTRL[1] | 87 | VSSC | 139 | D[14] | 191 | VSSIO |
| 36 | VSSC | 88 | VSSIO | 140 | D[15] | 192 | VDDIO |
| 37 | USBVUSDRV | 89 | VDDIO | 141 | SPICLK | 193 | VCO[0] |
| 38 | VDDC | 90 | NC | 142 | SPINCS[1] | 194 | PDOUT[0] |
| 39 | AV3DATA[0] | 91 | TEST5 | 143 | SPINCS[0] | 195 | AV4CLK |
| 40 | AV3DATA[1] | 92 | NC | 144 | VDDC | 196 | AV0CTRL[0] |
| 41 | MII TXCLK | 93 | TDI | 145 | VSSC | 197 | AV0CTRL[1] |
| 42 | MII TXER | 94 | TDO | 146 | SPIMISO | 198 | AV2CLK |
| 43 | VDDIO | 95 | VDDC | 147 | SPIMOSI | 199 | AV2CTRL[0] |
| 44 | AV3DATA[2] | 96 | VSSC | 148 | NTEST3 | 200 | AV2CTRL[1] |
| 45 | VSSIO | 97 | MII CRS | 149 | NTEST4 | 201 | VDDIO |
| 46 | AV3DATA[3] | 98 | MII COL | 150 | VSSIO | 202 | VSSIO |
| 47 | VDDUSB | 99 | GPIO[15] | 151 | VDDIO | 203 | XTALI |
| 48 | USB+ | 100 | GPIO[14] | 152 | A[0] | 204 | XTALO |
| 49 | USB- | 101 | GPIO[13] | 153 | A[1] | 205 | VDDPLL |
| 50 | VSSUSB | 102 | GPIO[12] | 154 | A[2] | 206 | VSSPLL |
| 51 | USBVUS | 103 | VDDIO | 155 | A[3] | 207 | VDDDCO |
| 52 | USBID | 104 | VSSIO | 156 | A[4] | 208 | VSSDCO |

ADSP-BF532 (IC101)

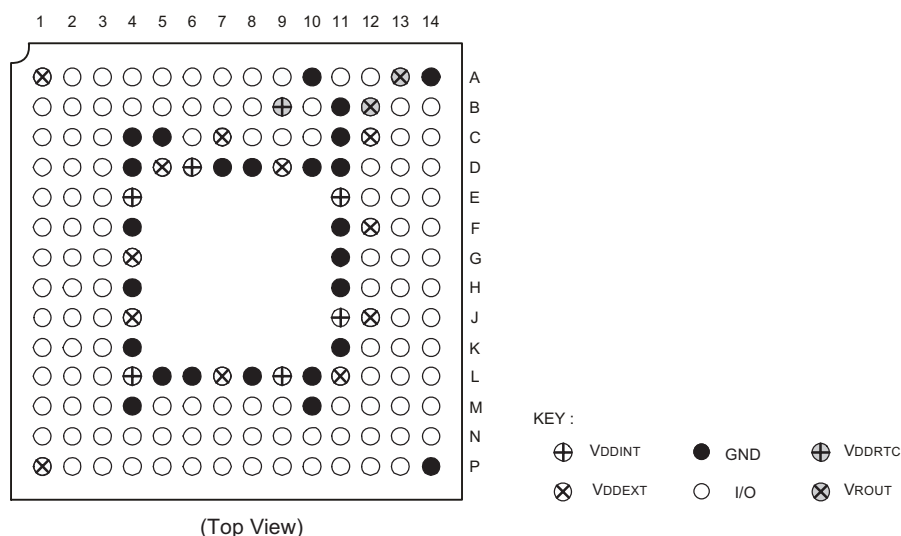

ADSP-BF532 Ball Number

| Ball No. | Signal | Ball No. | Signal | Ball No. | Signal | Ball No. | Signal |
|----------|---------|----------|--------|----------|--------|----------|--------|
| A1 | VDDEXT | C13 | SMS | H1 | DTOPRI | M3 | TDI |
| A2 | PF8 | C14 | SCAS | H2 | DTOSEC | M4 | GND |
| A3 | PF9 | D1 | SCK | H3 | TFS0 | M5 | DATA12 |
| A4 | PF10 | D2 | PF0 | H4 | GND | M6 | DATA9 |
| A5 | PF11 | D3 | MOSI | H11 | GND | M7 | DATA6 |
| A6 | PF14 | D4 | GND | H12 | ABE1 | M8 | DATA3 |
| A7 | PPI2 | D5 | VDDEXT | H13 | ABE0 | M9 | DATA0 |
| A8 | RTXO | D6 | VDDINT | H14 | AWE | M10 | GND |
| A9 | RTXI | D7 | GND | J1 | TSCLK0 | M11 | ADDR15 |
| A10 | GND | D8 | GND | J2 | DR0SEC | M12 | ADDR9 |
| A11 | XTAL | D9 | VDDEXT | J3 | RFS0 | M13 | ADDR10 |
| A12 | CLKIN | D10 | GND | J4 | VDDEXT | M14 | ADDR11 |
| A13 | VRROUT0 | D11 | GND | J11 | VDDINT | N1 | TRST |
| A14 | GND | D12 | SWE | J12 | VDDEXT | N2 | TMS |
| B1 | PF4 | D13 | SRA5 | J13 | ADDR4 | N3 | TDO |
| B2 | PF5 | D14 | BR | J14 | ADDR1 | N4 | BMODE0 |
| B3 | PF6 | E1 | TFS1 | K1 | DR0PRI | N5 | DATA13 |
| B4 | PF7 | E2 | MISO | K2 | TMR2 | N6 | DATA10 |
| B5 | PF12 | E3 | DT1SEC | K3 | TX | N7 | DATA7 |
| B6 | PF13 | E4 | VDDINT | K4 | GND | N8 | DATA4 |
| B7 | PPI3 | E11 | VDDINT | K11 | GND | N9 | DATA1 |
| B8 | PPI1 | E12 | SA10 | K12 | ADDR7 | N10 | BGH |
| B9 | VDDRTC | E13 | ARDY | K13 | ADDR5 | N11 | ADDR16 |
| B10 | NMI | E14 | AMS0 | K14 | ADDR2 | N12 | ADDR14 |
| B11 | GND | F1 | TSCLK1 | L1 | RSCLK0 | N13 | ADDR13 |
| B12 | VRROUT1 | F2 | DT1PRI | L2 | TMR0 | N14 | ADDR12 |
| B13 | SCKE | F3 | DR1SEC | L3 | RX | P1 | VDDEXT |
| B14 | CLKOUT | F4 | GND | L4 | VDDINT | P2 | TCK |
| C1 | PF1 | F11 | GND | L5 | GND | P3 | BMODE1 |
| C2 | PF2 | F12 | VDDEXT | L6 | GND | P4 | DATA15 |
| C3 | PF3 | F13 | AMS2 | L7 | VDDEXT | P5 | DATA14 |
| C4 | GND | F14 | AMS1 | L8 | GND | P6 | DATA11 |
| C5 | GND | G1 | RSCLK1 | L9 | VDDINT | P7 | DATA8 |
| C6 | PF15 | G2 | RFS1 | L10 | GND | P8 | DATA5 |
| C7 | VDDEXT | G3 | DR1PRI | L11 | VDDEXT | P9 | DATA2 |
| C8 | PPI0 | G4 | VDDEXT | L12 | ADDR8 | P10 | BG |
| C9 | PPI_CLK | G11 | GND | L13 | ADDR6 | P11 | ADDR19 |
| C10 | RESET | G12 | AMS3 | L14 | ADDR3 | P12 | ADDR18 |
| C11 | GND | G13 | AOE | M1 | TMR1 | P13 | ADDR17 |
| C12 | VDDEXT | G14 | ARE | M2 | EMU | P14 | GND |

M30879FKBGP (IC701)

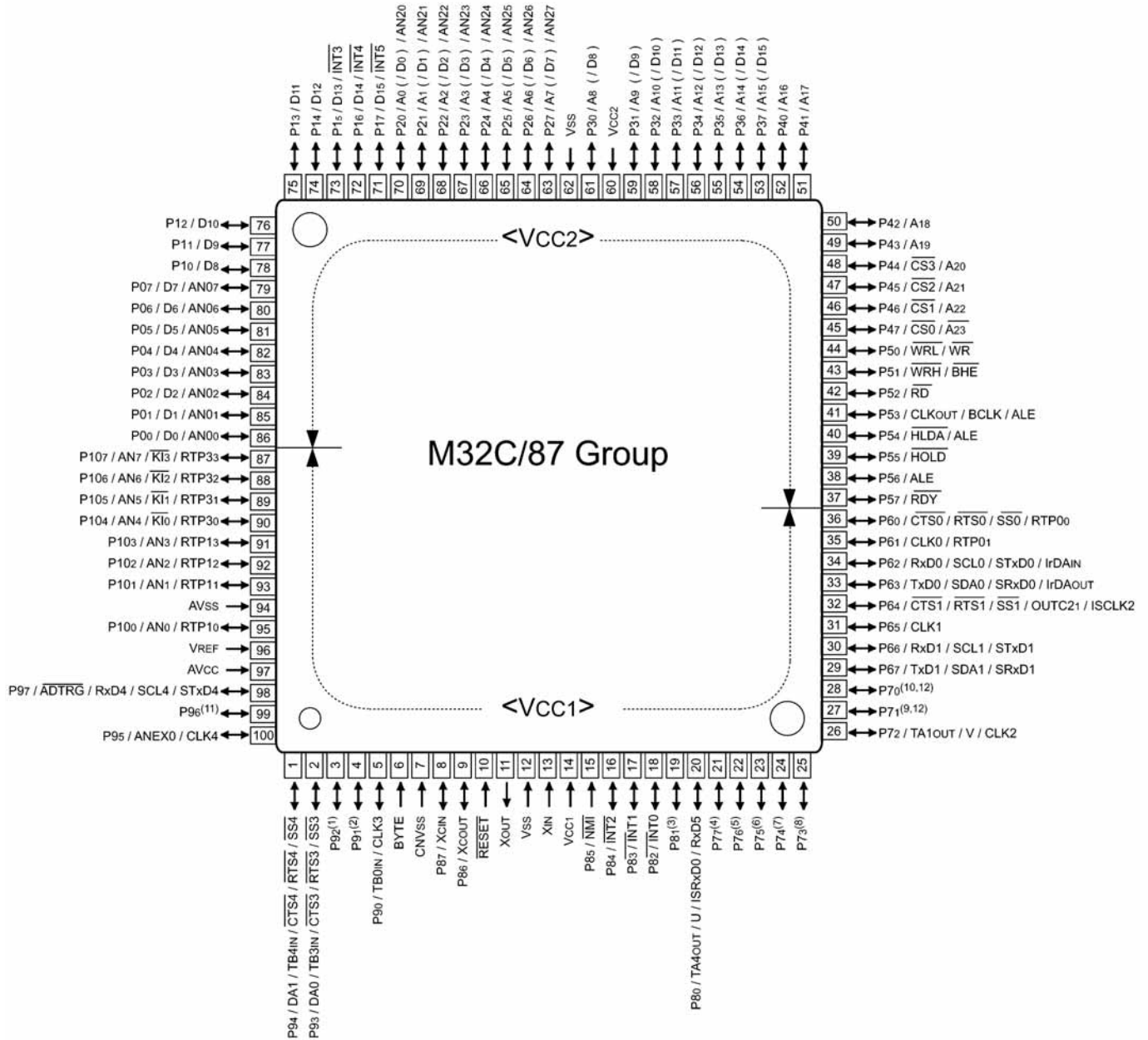

NOTES:

1. P92 / TB2IN / TxD3 / SDA3 / SRxD3 / OUTC20 / IEOUT / ISTxD2
2. P91 / TB1IN / RxD3 / SCL3 / STxD3 / IEIN / ISRxD2
3. P81 / TA4IN / \bar{U} / INPC15 / OUTC15 / CTS5 / RTS5 / RTP23
4. P77 / TA3IN / CAN0IN / INPC14 / OUTC14 / ISCLK0 / CLK5 / RTP22
5. P76 / TA3OUT / CAN0OUT / INPC13 / OUTC13 / ISTxD0 / TxD5
6. P75 / TA2IN / \bar{W} / INPC12 / OUTC12 / ISRxD1 / RTP21
7. P74 / TA2OUT / W / INPC11 / OUTC11 / ISCLK1 / RTP20
8. P73 / TA1IN / \bar{V} / CTS2 / RTS2 / SS2 / INPC10 / OUTC10 / ISTxD1
9. P71 / TA0IN / TB5IN / RxD2 / SCL2 / STxD2 / INPC17 / OUTC17 / OUTC22 / ISRxD2 / IEIN / RTP03
10. P70 / TA0OUT / TxD2 / SDA2 / SRxD2 / INPC16 / OUTC16 / OUTC20 / ISTxD2 / IEOUT / RTP02
11. P96 / ANEX1 / TxD4 / SDA4 / SRxD4
12. P70 and P71 are ports for the N-channel open drain output.

M30879FKBGP Pin Description

| Classification | Symbol | I/O Type | Supply Voltage | Function |
|---|-----------------------------|----------|---|---|
| Power Supply | VCC1, VCC2 VSS | I I | – | Apply 3.0 to 5.5V to both VCC1 and VCC2 pins. Apply 0V to the VSS pin. $V_{CC1} \geq V_{CC2}$ |
| Analog Power Supply | AVCC AVSS | I | VCC1 | Supplies power to the A/D converter. Connect the AVCC pin to VCC1 and the AVSS pin to VSS |
| Reset Input | RESET | I | VCC1 | The microcomputer is in a reset state when "L" is applied to the RESET pin |
| CNVss | CNVss | I | VCC1 | Switches processor mode. Connect the CNVss pin to VSS to start up in single-chip mode or to VCC1 to start up in microprocessor mode |
| Input to Switch External Data Bus Width | BYTE | I | VCC1 | Switches data bus width in external memory space 3. The data bus is 16 bits wide when the BYTE pin is held "L" and 8 bits wide when it is held "H". Set to either. Connect the BYTE pin to VSS to use the microcomputer in single-chip mode |
| Bus Control Pins | D0 to D7 | I/O | VCC2 | Inputs and outputs data (D0 to D7) while accessing an external memory space with separate bus |
| | D8 to D15 | I/O | VCC2 | Inputs and outputs data (D8 to D15) while accessing an external memory space with 16-bit separate bus |
| | A0 to A22 | O | VCC2 | Outputs address bits A0 to A22 |
| | A23 | O | VCC2 | Outputs inversed address bit A23 |
| | A0/D0 to A7/D7 | I/O | VCC2 | Inputs and outputs data (D0 to D7) and outputs 8 low-order address bits (A0 to A7) by time-sharing while accessing an external memory space with multiplexed bus |
| | A8/D8 to A15/D15 | I/O | VCC2 | Inputs and outputs data (D8 to D15) and outputs 8 middle-order address bits (A8 to A15) by time-sharing while accessing an external memory space with 16-bit multiplexed bus |
| | CS0 to CS3 | O | VCC2 | Outputs CS0 to CS3 that are chip-select signals specifying an external space |
| | WRL / WR WRH / BHE RD | O | VCC2 | Outputs WRL, WRH, (WR, BHE) and RD signals. WRL and WRH can be switched with WR and BHE by program. <ul style="list-style-type: none"> ■ WRL, WRH and RD selected: If external data bus is 16 bits wide, data is written to an even address in external memory space when WRL is held "L". Data is written to an odd address when WRH is held "L". Data is read when RD is held "L". ■ WR, BHE and RD selected: Data is written to external memory space when WR is held "L". Data in an external memory space is read when RD is held "L". An odd address is accessed when BHE is held "L". Select WR, BHE and RD for external 8-bit data bus |
| | ALE | O | VCC2 | ALE is a signal latching the address |
| | HOLD | I | VCC2 | The microcomputer is placed in a hold state while the HOLD pin is held "L" |
| HLDA | O | VCC2 | Outputs an "L" signal while the microcomputer is placed in a hold state | |
| RDY | I | VCC2 | Bus is placed in a wait state while the RDY pin is held "L" | |

I : Input O : Output I/O : Input and output

| Classification | Symbol | I/O Type | Supply Voltage | Function |
|-------------------------|--|----------|----------------|---|
| Reference Voltage Input | VREF | I | - | Supplies reference voltage to the A/D converter and D/A converter |
| A/D Converter | AN0 to AN7 AN00 to AN07 AN20 to AN27 | I | VCC1 | Analog input pins for the A/D converter |
| | ADTRG | I | VCC1 | Input pin for an external A/D trigger |
| | ANEX0 | I/O | VCC1 | Extended analog input pin for the A/D converter and output pin in external op-amp connection mode |
| | ANEX1 | I | VCC1 | Extended analog input pin for the A/D converter |
| D/A Converter | DA0, DA1 | O | VCC1 | Output pin for the D/A converter |
| Intelligent I/O | INPC10 to INPC13 | I | VCC1 | Input pins for the time measurement function |
| | INPC14 to INPC17 | I | VCC1 | |
| | OUTC10 to OUTC13 | O | VCC1 | Output pins for the waveform generating function (OUTC16/OUTC20 and OUTC17/OUTC21 assigned to P70 and P71 are pins for the N-channel open drain output.) |
| | OUTC14 to OUTC17 | O | VCC1 | |
| | OUTC20 to OUTC22 | O | VCC1 | |
| | ISCLK0 | I/O | VCC1 | Inputs and outputs the clock for the intelligent I/O communication function |
| | ISCLK1,ISCLK2 | I/O | VCC1 | |
| | ISRxD0 | I | VCC1 | Inputs data for the intelligent I/O communication function |
| | ISRxD1,ISRxD2 | I | VCC1 | |
| | ISTxD0 | O | VCC1 | Outputs data for the intelligent I/O communication function (ISTxD2 assigned to P70 are pins for the N-channel open drain output.) |
| | ISTxD1,ISTxD2 | O | VCC1 | |
| | IEIN | I | VCC1 | Inputs data for the intelligent I/O communication function |
| | IEOUT | O | VCC1 | Outputs data for the intelligent I/O communication function (IEOUT assigned to P70 are pins for the N-channel open drain output.) |
| CAN | CAN0in,CAN1in | I | VCC1 | Input pin for the CAN communication function |
| | CAN0out,CAN1out | O | VCC1 | Output pin for the CAN communication function |
| | CAN1WU | I | VCC1 | Input pin for the CAN1 wake-up interrupt |
| Real-Time Ports | RTP00 to RTP03 RTP10 to RTP13 RTP20 to RTP23 RTP30 to RTP33 | O | VCC1 | Output port working as the real-time ports (RTP02 and RTP03 are ports for the N-channel open drain output.) |
| I/O Ports | P00 to P07 P10 to P17 P20 to P27 P30 to P37 P40 to P47 P50 to P57 | I/O | VCC2 | 8-bit I/O ports in CMOS. Each port can be programmed to input or output under the control of the direction register. An input port can be set, by program, for a pull-up resistor available or for no pull-up resistor available in 4-bit units |
| | P60 to P67 P70 to P77 P90 to P97 P100 to P107 | I/O | VCC1 | 8-bit I/O ports having equivalent functions to P0 (P70 and P71 are ports for the N-channel open drain output.) |
| | P80 to P84 P86, P87 | I/O | VCC1 | I/O ports having equivalent functions to P0 |
| | Input Port | P85 | I | VCC1 |

I : Input O : Output I/O : Input and output

| Classification | Symbol | I/O Type | Supply Voltage | Function |
|---------------------|--|----------|----------------|--|
| Key Input Interrupt | KI0 to KI3 | I | VCC1 | Input pins for the key input interrupt |
| IrDA | IrDAIN | I | VCC1 | Input pin for IrDA serial data |
| | IrDAOUT | O | VCC1 | Output pin for IrDA serial data |
| INT Interrupt Input | INT6 to INT8 | I | VCC1 | Input pins for the INT interrupt |
| Serial I/O | CTS6 | I | Vcc1/Vcc2 | Input pins for data transmission control |
| | RTS6 | O | Vcc1/Vcc2 | Output pins for data reception control |
| | CLK6 | I/O | Vcc1/Vcc2 | Inputs and outputs the transfer clock |
| | RXD6 | I | Vcc1/Vcc2 | Inputs serial data |
| | TXD6 | O | Vcc1/Vcc2 | Outputs serial data |
| Intelligent I/O | OUTC23 to OUTC27 | O | Vcc2 | Output pins for the waveform generating function |
| A/D Converter | AN150 to AN157 | I | VCC1 | Analog input pins for the A/D converter |
| I/O Ports | P110 to P114 P120 to P127 P130 to P137 | I/O | Vcc2 | I/O ports having equivalent functions to P0 |
| | P140 to P146 P150 to P157 | I/O | VCC1 | I/O ports having equivalent functions to P0 |

I : Input O : Output I/O : Input and output

AK4683EQ (IC300)

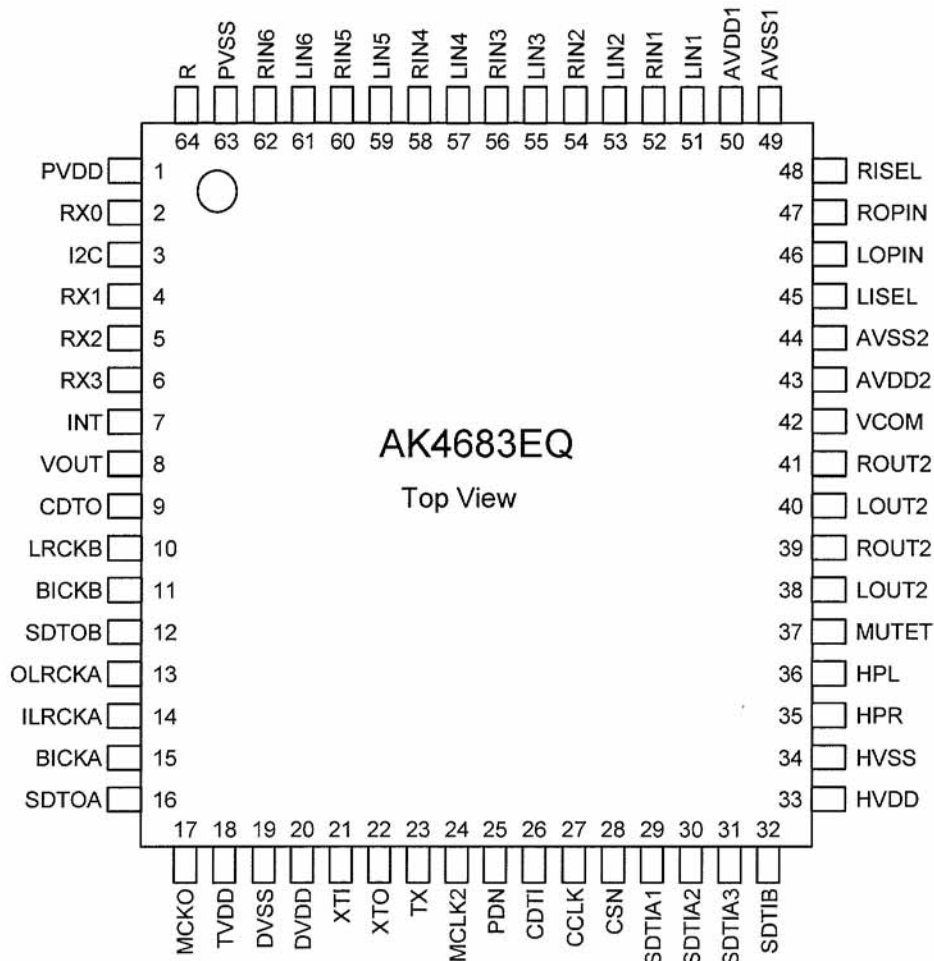

AK4683WQ Pin Function

| No. | Pin Name | I/O | Function |
|-----|----------|-----|--|
| 1 | PVDD | - | PLL Power supply Pin, 4.5V~5.5V |
| 2 | RX0 | I | Receiver Channel 0 Pin (Internal biased pin. Internally biased at PVDD/2) |
| 3 | I2C | I | Control Mode Select Pin. “L”: 4-wire Serial, “H”: I ² C Bus |
| 4 | RX1 | I | Receiver Channel 1 Pin |
| 5 | RX2 | I | Receiver Channel 2 Pin |
| 6 | RX3 | I | Receiver Channel 3 Pin |
| 7 | INT | O | Interrupt Pin |
| 8 | VOUT | O | V-bit Output Pin for Receiver Input |
| | DZF | O | Zero Input Detect Pin When the input data of DAC follow total 8192 LRCK cycles with “0” input data, this pin goes to “H”. And when RSTN1 bit is “0”, PWDA bit is “0”, this pin goes to “H”. |
| | OVF | O | Analog Input Overflow Detect Pin This pin goes to “H” if the analog input of Lch or Rch overflows. |
| 9 | CDTO | O | Control Data Output Pin in Serial Mode and I2C pin = “L”. |
| 10 | LRCKB | I/O | Channel Clock B Pin |
| 11 | BICKB | I/O | Audio Serial Data Clock B Pin |
| 12 | SDTOB | O | Audio Serial Data Output B Pin |
| 13 | OLRCKA | I/O | Output Channel Clock A Pin |
| 14 | ILRCKA | I/O | Input Channel Clock A Pin |
| 15 | BICKA | I/O | Audio Serial Data Clock A Pin |
| 16 | SDTOA | O | Audio Serial Data Output A Pin |
| 17 | MCKO | O | Master Clock Output Pin |
| 18 | TVDD | - | Output Buffer Power Supply Pin, 2.7V~5.5V |
| 19 | DVSS | - | Digital Ground Pin, 0V |
| 20 | DVDD | - | Digital Power Supply Pin, 4.5V~5.5V |
| 21 | XTI | I | X'tal Input Pin |
| 22 | XTO | O | X'tal Output Pin |
| 23 | TX | O | Transmit Channel Output pin When DIT bit = “0”, RX0~3 Through. When DIT bit = “1”, Internal DIT Output. |
| 24 | MCLK2 | I | Master Clock Input Pin |
| 25 | PDN | I | Power-Down Mode & Reset Pin When “L”, the AK4683 is powered-down, all registers are reset. And then all digital output pins go “L”. The AK4683 must be reset once upon power-up. |
| 26 | CDTI | I | Control Data Input Pin in Serial Mode and I2C pin = “L”. |
| | SDA | I/O | Control Data Pin in Serial Mode and I2C pin = “H”. |
| 27 | CCLK | I | Control Data Clock Pin in Serial Mode and I2C pin = “L” |
| | SCL | I | Control Data Clock Pin in Serial Mode and I2C pin = “H” |
| 28 | CSN | I | Chip Select Pin in Serial Mode and I2C pin = “L”. |
| | TEST | I | This pin should be connected to DVSS in Serial Mode and I2C pin = “H”. |
| 29 | SDTIA1 | I | Audio Serial Data Input A1 Pin |
| 30 | SDTIA2 | I | Audio Serial Data Input A2 Pin |
| 31 | SDTIA3 | I | Audio Serial Data Input A3 Pin |
| 32 | SDTIB | I | Audio Serial Data Input B Pin |
| 33 | HVDD | - | HP Power Supply Pin, 4.5V~5.5V |
| 34 | HVSS | - | HP Ground Pin, 0V |
| 35 | HPR | O | HP Rch Output Pin |
| 36 | HPL | O | HP Lch Output Pin |
| 37 | MUTET | - | HP Common Voltage Output Pin 1 μ F capacitor should be connected to HVSS externally. |

| No. | Pin Name | I/O | Function |
|-----|----------|-----|---|
| 38 | LOUT2 | O | DAC2 Lch Positive Analog Output Pin |
| 39 | ROUT2 | O | DAC2 Rch Positive Analog Output Pin |
| 40 | LOUT1 | O | DAC1 Lch Positive Analog Output Pin |
| 41 | ROUT1 | O | DAC1 Rch Positive Analog Output Pin |
| 42 | VCOM | - | DAC/ADC Common Voltage Output Pin 2.2 μ F capacitor should be connected to AVSS2 externally. |
| 43 | AVDD2 | - | DAC Power Supply Pin, 4.5V~5.5V |
| 44 | AVSS2 | - | DAC Ground Pin, 0V |
| 45 | LISEL | O | Lch Feedback Resistor Output Pin |
| 46 | LOPIN | O | Lch Feedback Resistor Input Pin. 0.5 x AVDD1. |
| 47 | ROPIN | O | Rch Feedback Resistor Input Pin. 0.5 x AVDD1. |
| 48 | RISEL | O | Rch Feedback Resistor Output Pin |
| 49 | AVSS1 | - | ADC Ground Pin, 0V |
| 50 | AVDD1 | - | ADC Power Supply Pin, 4.5V~5.5V |
| 51 | LIN1 | I | Lch Input 1 Pin |
| 52 | RIN1 | I | Rch Input 1 Pin |
| 53 | LIN2 | I | Lch Input 2 Pin |
| 54 | RIN2 | I | Rch Input 2 Pin |
| 55 | LIN3 | I | Lch Input 3 Pin |
| 56 | RIN3 | I | Rch Input 3 Pin |
| 57 | LIN4 | I | Lch Input 4 Pin |
| 58 | RIN4 | I | Rch Input 4 Pin |
| 59 | LIN5 | I | Lch Input 5 Pin |
| 60 | RIN5 | I | Rch Input 5 Pin |
| 61 | LIN6 | I | Lch Input 6 Pin |
| 62 | RIN6 | I | Rch Input 6 Pin |
| 63 | PVSS | - | PLL Ground pin |
| 64 | R | - | External Resistor Pin 12k Ω +/-1% resistor should be connected to PVSS externally. |

Note: All input pins except internal biased pin (RX0) and analog input pins (LIN1-6, RIN1-6) should not be left floating.

■ Handling of Unused Pin

The unused I/O pins should be processed appropriately as below.

| Classification | Pin Name | Setting |
|----------------|--|---|
| Analog | RX0, LOUT1-2, ROUT1-2, LIN1-6, RIN1-6 | These pins should be open. |
| Digital | INT, XTO, MCKO, VOUT/DZF/OVF, SDTOA-B, CDTO, TX | These pins should be open. |
| | RX1-3, CSN, CCLK, CDTI, XTI, MCLK2, OLRCKA, ILRCKA, BICKA, SDTIA1-3, LRCKB, BICKB, SDTIB | These pins should be connected to DVSS. |

1U-3846 MAIN P.W.B. UNIT (2/2)

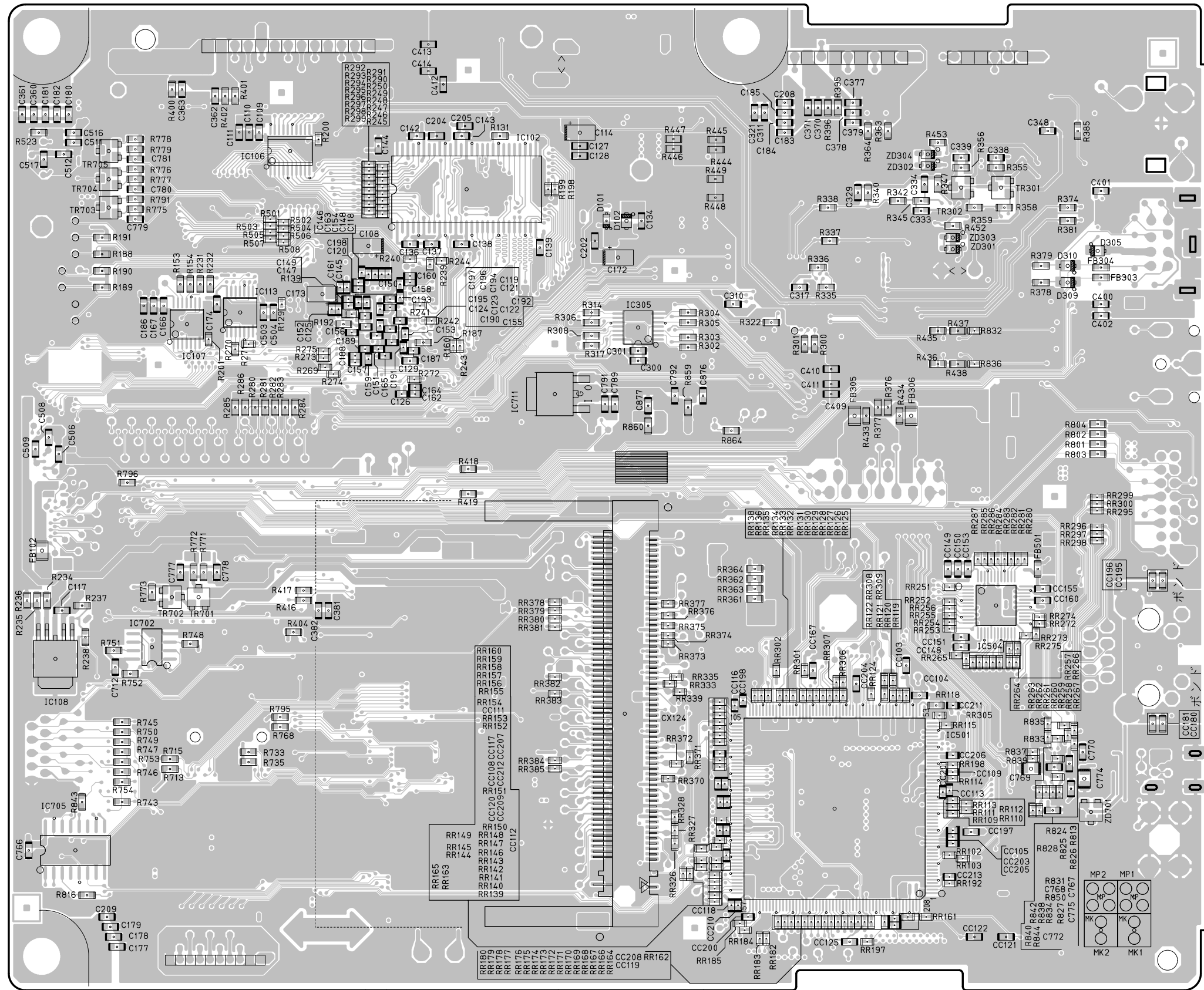

FOIL SIDE

1U-3847 VIDEO P.W.B. UNIT (2/2)

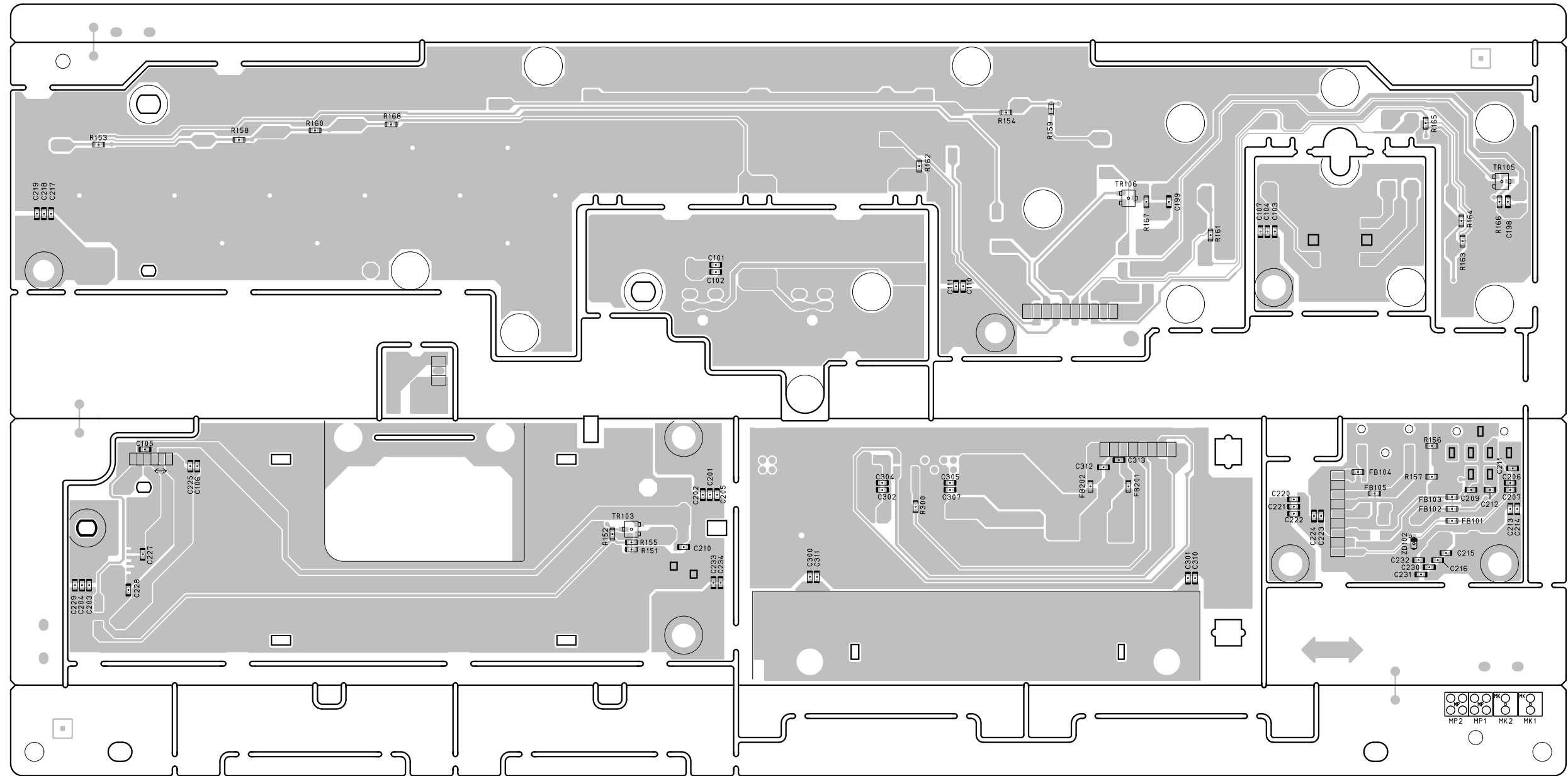

FOIL SIDE

1U-3851 L.PWR/DISP P.W.B. UNIT (1/2)

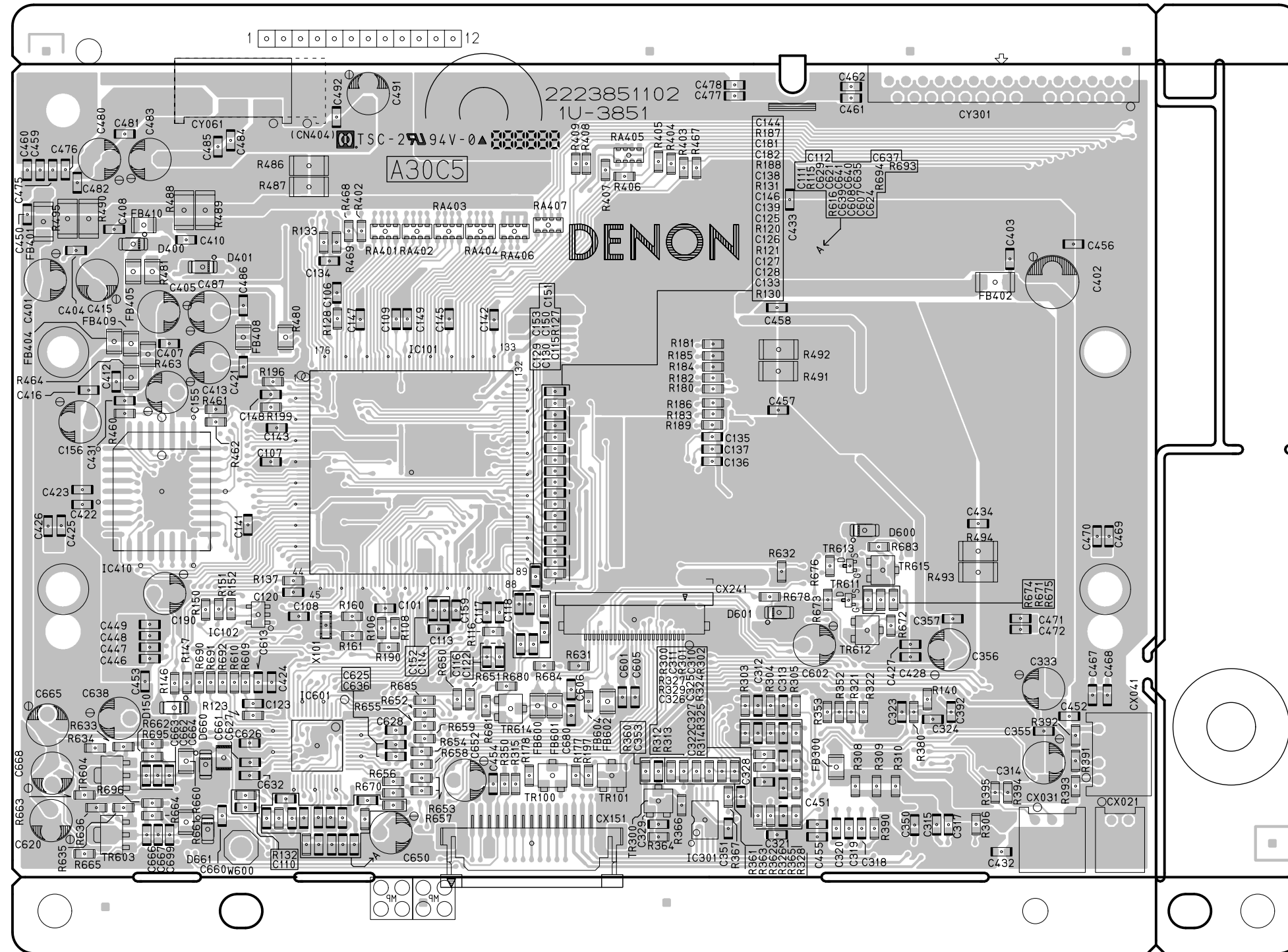

1U-3851 L.PWR/DISP P.W.B. UNIT (2/2)

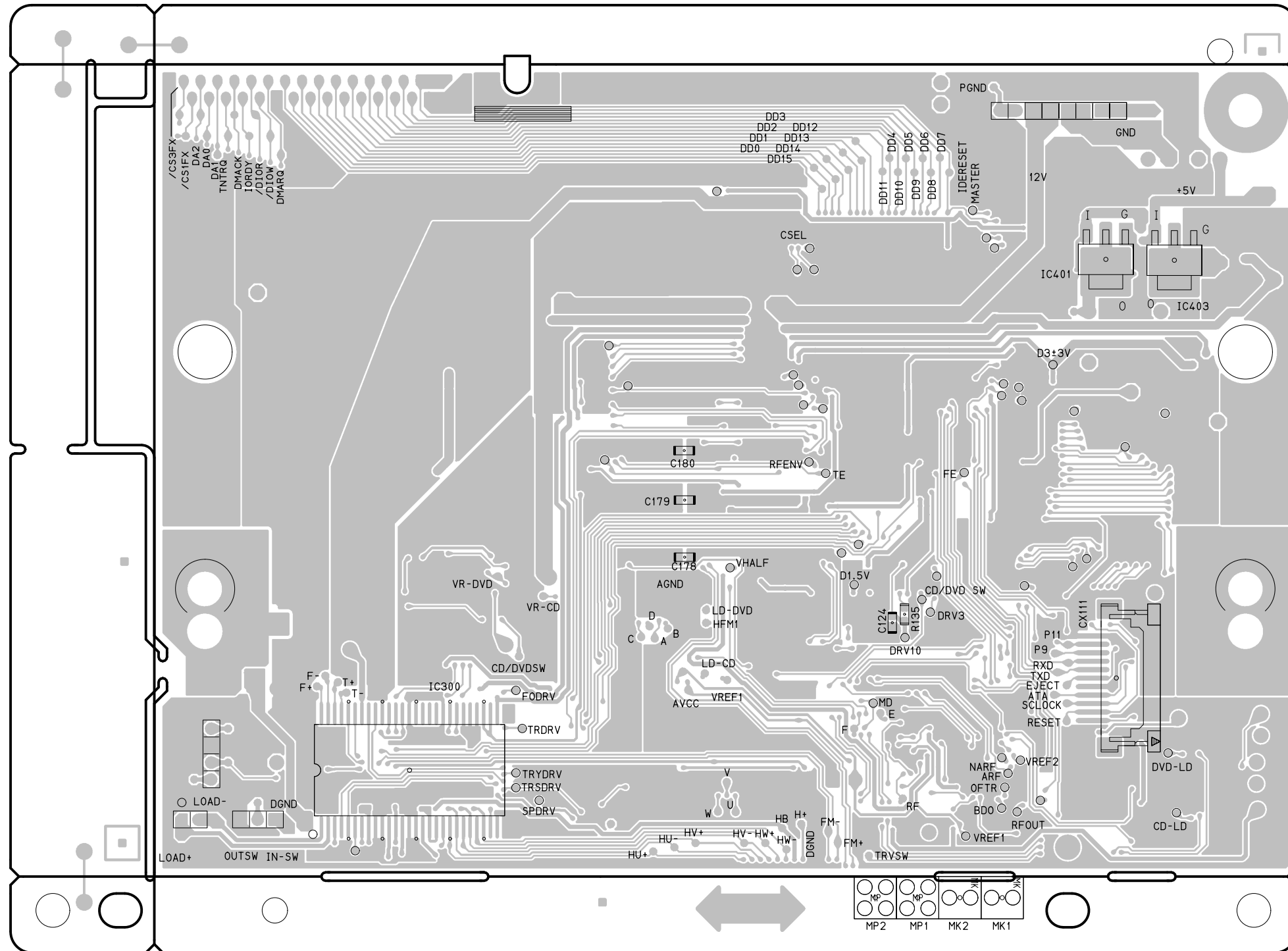

FOIL SIDE

1U-3859 D.AMP/SMPS P.W.B. UNIT (1/2)

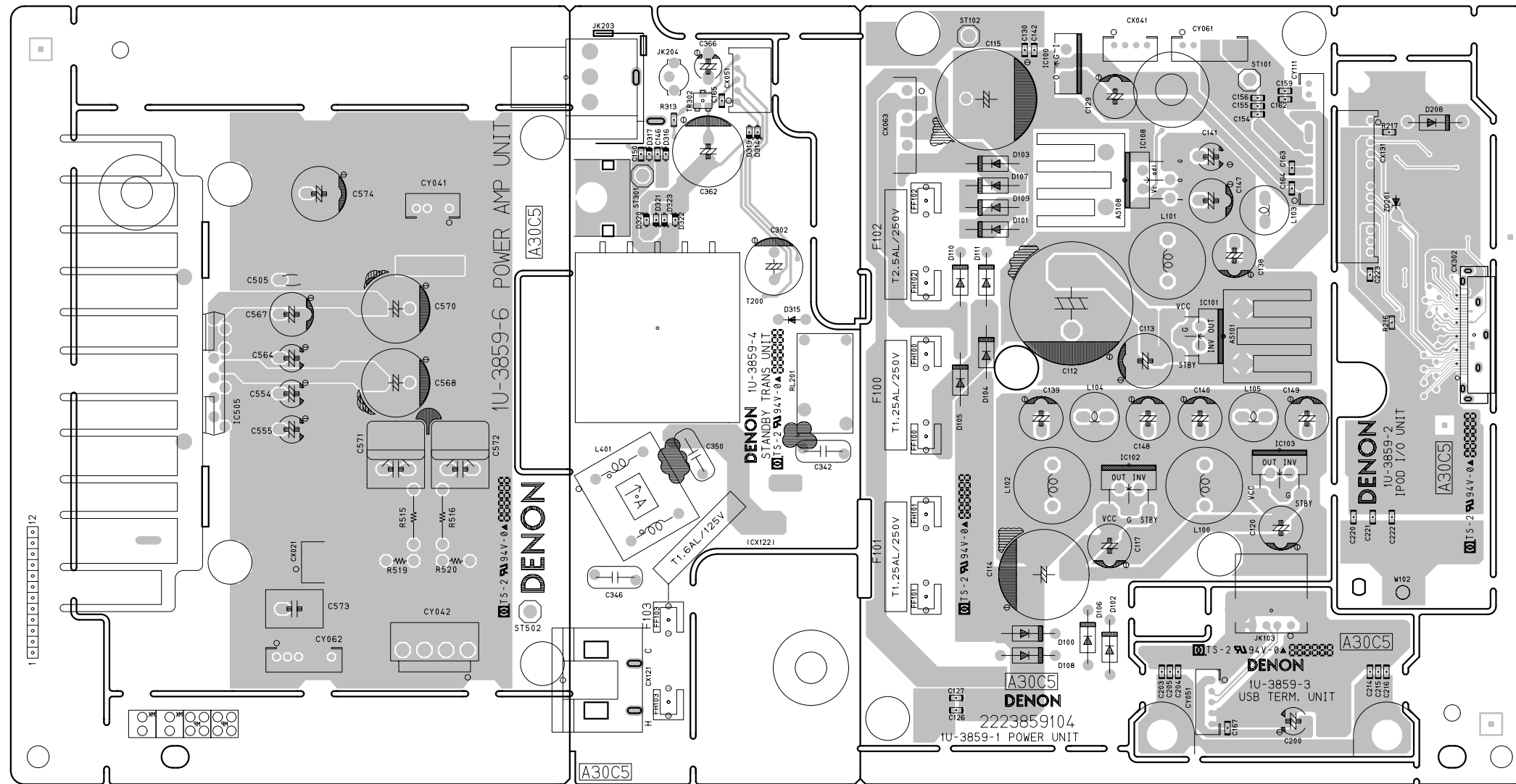

1U-3859 D.AMP/SMPS P.W.B. UNIT (2/2)

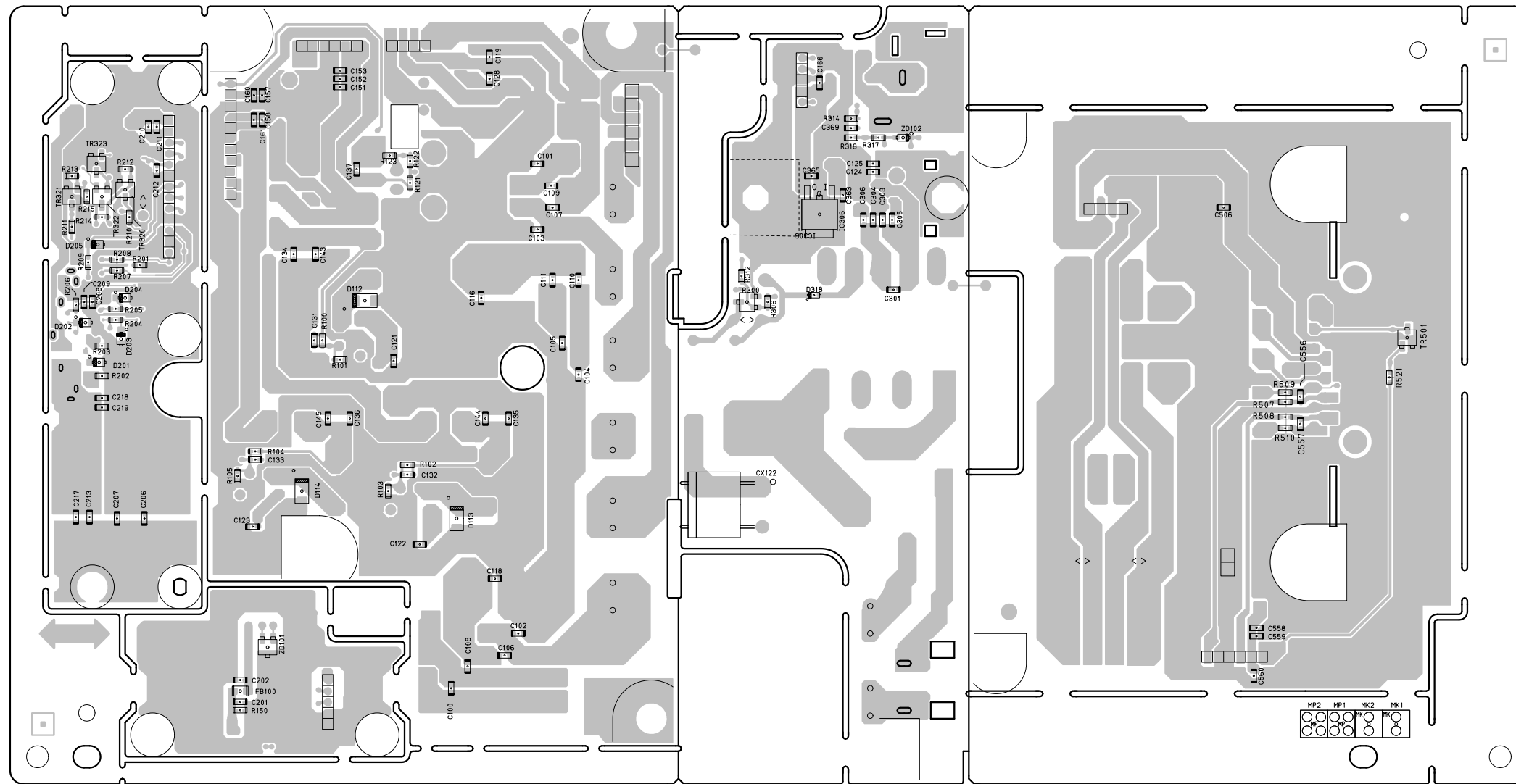

FOIL SIDE

NOTE FOR PARTS LIST

- Parts for which "nsp" is indicated on this table cannot be supplied.
- When ordering of part, clearly indicate "1" and "I" (i) to avoid mis-supplying.
- Ordering part without stating its part number can not be supplied.
- Part indicated with the mark "★" is not illustrated in the exploded view.
- Not including General-purpose Carbon Film Resistor in the P.W.Board parts list. (Refer to the Schematic Diagram for those parts.)
- Not including General-purpose Carbon Chip Resistor in the P.W.Board parts list. (Refer to the Schematic Diagram for those parts.)

WARNING:

Parts marked with this symbol \triangle have critical characteristics. Use ONLY replacement parts recommended by the manufacturer.

● Resistors

Ex.: RN 14K 2E 182 G FR

| Type | Shape and performance | Power | Resistance | Allowable error | Others |
|---|---|---|---|-----------------|--------|
| RD : Carbon RC : Composition RS : Metal oxide film RW : Winding RN : Metal film RK : Metal mixture | 2B : 1/8W 2E : 1/4W 2H : 1/2W 3A : 1W 3D : 2W 3F : 3W 3H : 5W | F : ±1% G : ±2% J : ±5% K : ±10% M : ±20% | P : Pulse-resistant type NL : Low noise type NB : Non-burning type FR : Fuse-resistor F : Lead wire forming | | |

* Resistance

1 8 2 ⇒ 1800 ohm = 1.8 kohm
Indicates number of zeros after effective number.
2-digit effective number.

• Units: ohm

1 R 2 ⇒ 1.2 ohm
1-digit effective number.
2-digit effective number, decimal point indicated by R.

• Units: ohm

● Capacitors

Ex.: CE 04W 1H 2R2 M BP

| Type | Shape and performance | Dielectric strength | Capacity | Allowable error | Others |
|---|--|--|---|-----------------|--------|
| CE : Aluminum foil electrolytic CA : Aluminum solid electrolytic CS : Tantalum electrolytic CQ : Film CK : Ceramic CC : Ceramic CP : Oil CM : Mica CF : Metallized CH : Metallized | 0J : 6.3V 1A : 10V 1C : 16V 1E : 25V 1V : 35V 1H : 50V 2A : 100V 2B : 125V 2C : 160V 2D : 200V 2E : 250V 2H : 500V 2J : 630V | F : ±1% G : ±2% J : ±5% K : ±10% M : ±20% Z : +80% -20% P : +100% -0% C : ±0.25pF D : ±0.5pF = : Others | HS : High stability type BP : Non-polar type HR : Ripple-resistant type DL : For change and discharge HF : For assuring high frequency U : UL part C : CSA part W : UL-CSA type F : Lead wire forming | | |

* Capacity (electrolyte only)

2 2 2 ⇒ 2200μF
Indicates number of zeros after effective number.
2-digit effective number.

• Units: μF.

2 R 2 ⇒ 2.2μF
1-digit effective number.
2-digit effective number, decimal point indicated by R.

• Units: μF.

* Capacity (except electrolyte)

2 2 2 ⇒ 2200pF=0.0022μF
(More than 2) Indicates number of zeros after effective number.
2-digit effective number.

• Units: pF.

2 2 1 ⇒ 220pF
(0 or 1) Indicates number of zeros after effective number.
2-digit effective number.

• Units: pF.

• When the dielectric strength is indicated in AC, "AC" is included after the dielectric strength value.

部品表について

- 部品表に "nsp" と記載されている部品は供給できません。
- 部品を発注する際は特に数字の "1" と英字の "I" との区別をはっきり記入してください。
- 部品番号を表示していない部品は供給できません。
- \triangle 印の部品は安全上重要な部品です。交換するときは、安全および性能維持のため必ず指定の部品をご使用ください。
- ★印のついている部品は分解図中には記載していません。
- 汎用カーボン抵抗器は記載していません。定数は回路図を参照願います。
- 汎用カーボンチップ抵抗器は記載していません。定数は回路図を参照願います。
- 部品表の抵抗器、コンデンサの品名記号の読み方は表を参照してください。

● 抵抗器

例) RN 14K 2E 182 G FR

| RN 種類 | 14K 形状特性 | 2E 電力 | 182 抵抗値 | G 許容差 | FR その他 |
|---|--|---|---|-------|--------|
| RD : カーボン RC : 固定体 RS : 金属系皮膜 RW : 巻線 RN : 金属皮膜 RK : 金属混合体 | 2B : 1/8 W 2E : 1/4 W 2H : 1/2 W 3A : 1 W 3D : 2 W 3F : 3 W 3H : 5 W | F : ±1% G : ±2% J : ±5% K : ±10% M : ±20% | P : 耐パルス形 NL : 低雑音形 NB : 不燃形 FR : ヒューズ抵抗 F : リード線成形 | | |

* 抵抗値

18 2 ⇒ 1800Ω=1.8kΩ
有効数字につづく0の数を表わす。
2桁の有効数字を表わす。

1R 2 ⇒ 1.2Ω
1桁の有効数字を表わす。
2桁の有効数字で小数点はRで表わす。
単位はΩ

● コンデンサ

例) CE 04W 1H 2R2 M BP

| CE 種類 | 04W 形状特性 | 1H 耐圧 | 2R2 容量 | M 許容差 | BP その他 |
|--|---|---|---|-------|--------|
| CE : アルミ箔電解 CA : アルミ固体電解 CS : タンタル電解 CQ : フィルム CK : セラミック CP : セラミック CM : オイル CF : マイカ CH : メタライズド | 0J : 6.3 V 1A : 10 V 1C : 16 V 1E : 25 V 1V : 35 V 1H : 50 V 2A : 100 V 2B : 125 V 2C : 160 V 2D : 200 V 2E : 250 V 2H : 500 V 2J : 630 V | F : ±1% G : ±2% J : ±5% K : ±10% M : ±20% Z : +80% -20% P : +100% -0% C : ±0.25pF D : ±0.5pF = : その他 | HS : 高安定形 BP : 無極性形 HR : 耐リップル形 DL : 充放電対策用 HF : 高周波保証用 U : UL 部品 C : CSA 部品 W : UL-CSA 部品 F : リード線成形 | | |

* 容量値

● 電解コンデンサの場合

22 2 ⇒ 2200μF
有効数字につづく0の数を表わす。
2桁の有効数字を表わす。
単位はμF

2R 2 ⇒ 2.2μF
1桁の有効数字を表わす。
2桁の有効数字で小数点はRで表わす。
単位はμF

● 電解コンデンサ以外の場合

22 2 ⇒ 2200pF=0.0022μF
有効数字につづく0の数を表わす。
(0の数が2以上の場合)
2桁の有効数字を表わす。
単位はpF

22 1 ⇒ 220pF
有効数字につづく0の数を表わす。
(0の数が0または1の場合)
2桁の有効数字を表わす。
単位はpF

● 耐圧を交流で表示する場合は、耐圧表示の次に「AC」を表示します。

PARTS LIST OF P.W.B. UNIT

* 本表に "nsp" と記載されている部品は供給できません。

* Parts for which "nsp" is indicated on this table cannot be supplied.

* 本表に記載されている部品は、補修用部品のため製品に使用している部品とは一部、形状、寸法などが異なる場合があります。

* The parts listed below are for maintenance only, might differ from the parts used in the unit in appearances or dimensions.

Note: The symbols in the column "Remarks" indicate the following destinations.

E3 : U.S.A. & Canada model

E2 : Europe model

EK : U.K. model

JP : Japan model

1U-3846 MAIN P.W.B. UNIT ASS'Y

| Ref. No. | Part No. | Part Name | Remarks | Q'ty | New |
|-----------------------------|------------------|------------------------------------|-------------------------|------|-----|
| SEMICONDUCTORS GROUP | | | | | |
| IC101 | nsp | ADSP-BF532SBBCZC11 | | | * |
| IC102 | 00D 262 3685 004 | W9812G6GH-6 | | | |
| IC103 | 00D GEN 8694 -06 | DSP ROM ASSY (K8D1716UBC-PI07) | for S-52E2/DABEK,S-32E2 | | * |
| IC103 | 00D GEN 8694 -04 | DSP ROM ASSY (K8D1716UBC-PI07) | for S-52JP | | |
| IC103 | 00D GEN 8694 -06 | DSP ROM ASSY (K8D1716UBC-PI07) | for S-52E3,S-32E3 | | |
| IC106 | 00D 262 2642 909 | SN74LV573APWR +REF | | | |
| IC107 | 00D 262 2729 903 | SN74LV02APW-EL2 +C | | | |
| IC108 | 00D 263 1236 908 | BA00BCOWFP | | | |
| IC110 | 00D 262 3400 904 | TPC6103 | | | |
| IC111,112 | 00D 262 2640 901 | SN74LV245APW-EL2 | for S-52 | | |
| IC113 | 00D 262 2516 909 | SN74LV32APW-EL2 +C | for S-52 | | |
| IC300 | 00D 262 3762 008 | AK4683EQ | | | * |
| IC301 | 00D 263 0615 902 | BA15218F-DXE2 +C | | | |
| IC302 | 00D 262 2977 933 | BA50BC0FP-E2 | | | |
| IC303 | 00D 262 1953 903 | TC7WU04F +C | | | |
| IC304 | 00D 263 0615 902 | BA15218F-DXE2 +C | | | |
| IC305 | 00D 262 2785 905 | SN74LV125APWRG4 +C | for S-52E3 | | |
| IC306 | 00D 262 3360 905 | LC72722PM-TLM | for S-52E2/DABEK,S-32E2 | | |
| IC307 | 00D 262 2953 902 | SN74HCT244APW +C | | | |
| IC308 | 00D 262 2517 908 | SN74LV08APW-EL2 +REF | | | |
| IC501 | 00D 262 3523 108 | BCOIC-DM850E-CQL | | | |
| IC502 | 00D GEN 8695 -12 | DM850 ROM ASSY (K8D3216UBC-PI07) | for S-52E2/DABEK | | |
| IC502 | 00D GEN 8695 -13 | DM850 ROM ASSY (K8D3216UBC-PI07) | for S-32E2 | | |
| IC502 | 00D GEN 8695 -10 | DM850 ROM ASSY (K8D3216UBC-PI07) | for S-52JP | | |
| IC502 | 00D GEN 8695 -12 | DM850 ROM ASSY (K8D3216UBC-PI07) | for S-52E3 | | |
| IC502 | 00D GEN 8695 -13 | DM850 ROM ASSY (K8D3216UBC-PI07) | for S-32E3 | | |
| IC503 | 00D 262 3685 004 | W9812G6GH-6 | | | |
| IC504 | 00D 262 3712 003 | RTL8201CP | | | |
| IC505 | 00D 262 3522 905 | MIC2025-1YM | for S-52 | | |
| IC506 | 00D 262 3412 905 | TC74VHC14FT | | | |
| IC511 | 00D 263 1290 902 | BA33DD0WHFP | | | |
| IC512 | 00D 263 1110 901 | PQ070XZ01ZP +C | | | |
| IC513 | 00D 262 2516 909 | SN74LV32APW-EL2 +C | | | |
| IC701 | 00D GEN 8693 -0A | S52/S32 SYS ROM ASSY (M30879FKBGP) | for S-52E2/DABEK,S-32E2 | | * |
| IC701 | 00D GEN 8693 -0A | S52/S32 SYS ROM ASSY (M30879FKBGP) | for S-52JP | | |
| IC701 | 00D GEN 8693 -0A | S52/S32 SYS ROM ASSY (M30879FKBGP) | for S-52E3,S-32E3 | | |
| IC702 | 00D 262 3707 908 | BR25L640F-WE2 | | | |
| IC703 | 235 010 0075 07S | BD4727G 2.7V RESET IC | | | |
| IC705 | 00D 262 2643 908 | TC4052BF(TAPE) | for S-52E3 | | |

ご注意：
ファームウェアをアップデートするときは、SDIで最終バージョンを確認して下さい。サービス基板はアップデートして使用下さい。

NOTE：
When update Firmware, please confirm a last version in SDI. Use the service board after updating it.

ご注意：
ファームウェアをアップデートするときは、SDIで最終バージョンを確認して下さい。サービス基板はアップデートして使用下さい。

NOTE：
When update Firmware, please confirm a last version in SDI. Use the service board after updating it.

| Ref. No. | Part No. | Part Name | Remarks | Q'ty | New |
|-------------------------|------------------|---------------------------|-------------------------------|------|-----|
| IC707 | 00D 262 3742 905 | F2621E-01 | for S-52E3 | | |
| IC708 | 00D 273 0492 902 | SP8K3FU6TB | for S-52E3 | | |
| IC711 | 00D 262 2977 946 | BA33BC0FP-E2 +REF | for S-52E3/DABEK | | |
| IC871 | 00D 263 0673 902 | BA10393F-E2 +C | | | |
| TR301,302 | 00D 273 0460 905 | KTC2875-B-RTK/P | | | |
| TR304,305 | 00D 269 0192 902 | KRC102S-RTK/P (10K-10K) | for S-52E2/DABEK/JP,S-32E3/E2 | | |
| TR306 | 00D 269 0184 907 | KRA102S-RTK/P (10K-10K) | for S-52E2/DABEK/JP,S-32E3/E2 | | |
| TR307 | 00D 271 0331 902 | 2SA2092QTL | for S-52E2/DABEK/JP,S-32E3/E2 | | |
| TR308 | 00D 269 0192 902 | KRC102S-RTK/P (10K-10K) | for S-52E2/DABEK/JP,S-32E3/E2 | | |
| TR309 | 00D 273 0464 901 | KTC3875S-GR-RTK/P | for S-52E2/DABEK,S-32E2 | | |
| TR310 | 00D 273 0460 905 | KTC2875-B-RTK/P | | | |
| TR311 | 00D 269 0192 902 | KRC102S-RTK/P (10K-10K) | for S-52E3/E2/DABEK,S-32E3/E2 | | |
| TR312 | 00D 269 0086 908 | DTA114TKT96 +C | for S-52E3/E2/DABEK,S-32E3/E2 | | |
| TR313 | 00D 273 0485 906 | KRC107S-RTK(10K-47K) | for S-52E3/E2/DABEK,S-32E3/E2 | | |
| TR314 | 00D 272 0127 902 | 2SB1182TL(R) | for S-52E3/E2/DABEK,S-32E3/E2 | | |
| TR315 | 00D 269 0184 907 | KRA102S-RTK/P (10K-10K) | for S-52E3 | | |
| TR316 | 00D 269 0192 902 | KRC102S-RTK/P (10K-10K) | for S-52E3 | | |
| TR317 | 00D 269 0192 902 | KRC102S-RTK/P (10K-10K) | | | |
| TR318 | 00D 271 0331 902 | 2SA2092QTL | | | |
| TR501,502 | 00D 269 0192 902 | KRC102S-RTK/P (10K-10K) | | | |
| TR505 | 00D 269 0193 901 | KRC104S-RTK/P (47K-47K) | | | |
| TR506 | 00D 269 0184 907 | KRA102S-RTK/P (10K-10K) | | | |
| TR701 | 00D 269 0184 907 | KRA102S-RTK/P (10K-10K) | for S-52E3 | | |
| TR702 | 00D 269 0192 902 | KRC102S-RTK/P (10K-10K) | for S-52E3 | | |
| TR703-705 | 00D 269 0192 902 | KRC102S-RTK/P (10K-10K) | | | |
| D101 | 00D 276 0750 902 | RB521S-30TE61 +REF | | | |
| D102 | 00D 276 0794 900 | KDS160-RTK/P | | | |
| D305 | 00D 276 0794 900 | KDS160-RTK/P | for S-52E3 | | |
| D309,310 | 00D 276 0794 900 | KDS160-RTK/P | for S-52E3 | | |
| D701-703 | 00D 276 0794 900 | KDS160-RTK/P | | | |
| ZD203 | 00D 276 0463 914 | HZS6C-2TD | | | |
| ZD501,502 | 00D 276 0837 906 | NSAD500F-T1B-A | | | |
| ZD701 | 00D 276 0837 906 | NSAD500F-T1B-A | for S-52E3 | | |
| RESISTORS GROUP | | | | | |
| R370,371 | 00D 235 0130 903 | CHIP EMIFIL(11A121) +1608 | | | |
| R372,373 | nsp | CK73B1H332KT +1608 | | | |
| R403 | 00D 244 2051 945 | RS14B3A010JNBST(S) | | | |
| R428,429 | 00D 235 0130 903 | CHIP EMIFIL(11A121) +1608 | for S-52E2/DABEK/JP,S-32E3/E2 | | |
| R806,807 | nsp | RM73B20R0KT +3216 | for S-52E3 | | |
| R856,857 | 00D 235 0130 903 | CHIP EMIFIL(11A121) +1608 | for S-52E3 | | |
| RR118 | 00D 247 2024 913 | RM73B--6041DT(1608) | | | |
| RR361 | 00D 247 2027 907 | RM73B--511FT +1608 | | | |
| RR364 | 00D 247 2019 902 | RM73B--102FT +1608 | | | |
| RR401 | nsp | RM73B20R0KT +3216 | for S-52JP | | |
| CAPACITORS GROUP | | | | | |
| C108 | 00D 257 2018 900 | CS77B1A100MT(NOJ) | | | |
| C109 | nsp | CK73F1E104ZT +1608 | | | |
| C110 | nsp | CK73F1H103ZT +1608 | | | |

| | Ref. No. | Part No. | Part Name | Remarks | Q'ty | New |
|--|----------|------------------|---------------------|------------|------|-----|
| | C111 | nsp | CK73B1H102KT +1608 | | | |
| | C112 | nsp | CK73F1H103ZT +1608 | | | |
| | C113 | nsp | CK73B1H102KT +1608 | | | |
| | C114 | 00D 257 2018 900 | CS77B1A100MT(NOJ) | | | |
| | C115 | nsp | CK73F1E104ZT +1608 | | | |
| | C116 | 00D 254 4740 921 | CE67W1C470MT(GV) | | | |
| | C117 | nsp | CK73F1E104ZT +1608 | | | |
| | C118-126 | nsp | CK73B1H102KT +1005 | | | |
| | C127 | nsp | CK73F1H103ZT +1608 | | | |
| | C128,129 | nsp | CK73B1H102KT +1608 | | | |
| | C130 | nsp | CC73CH1H470JT +1608 | | | |
| | C131-136 | nsp | CK73F1E104ZT +1608 | | | |
| | C137 | nsp | CK73F1H103ZT +1608 | | | |
| | C138 | nsp | CK73F1E104ZT +1608 | | | |
| | C139 | nsp | CK73F1H103ZT +1608 | | | |
| | C140 | 00D 254 4740 921 | CE67W1C470MT(GV) | | | |
| | C141,142 | nsp | CK73F1E104ZT +1608 | | | |
| | C143 | nsp | CK73F1H103ZT +1608 | | | |
| | C144 | nsp | CK73F1E104ZT +1608 | | | |
| | C145-165 | 00D 257 5009 974 | CK73F1C104ZT +1005 | | | |
| | C166 | nsp | CK73F1E104ZT +1608 | | | |
| | C167 | nsp | CK73F1H103ZT +1608 | | | |
| | C168-171 | 00D 254 4740 921 | CE67W1C470MT(GV) | | | |
| | C172,173 | 00D 257 2018 900 | CS77B1A100MT(NOJ) | | | |
| | C174 | nsp | CK73F1E104ZT +1608 | for S-52 | | |
| | C175-177 | nsp | CK73F1E104ZT +1608 | | | |
| | C178 | nsp | CK73F1H103ZT +1608 | | | |
| | C179 | nsp | CK73B1H102KT +1608 | | | |
| | C183 | nsp | CK73F1E104ZT +1608 | | | |
| | C184 | nsp | CK73F1H103ZT +1608 | | | |
| | C185,186 | nsp | CK73B1H102KT +1608 | | | |
| | C187-198 | nsp | CK73B1H102KT +1005 | | | |
| | C199,200 | nsp | CK73B1H102KT +1608 | | | |
| | C201 | nsp | CK73F1H103ZT +1608 | | | |
| | C203-205 | nsp | CK73B1H102KT +1608 | | | |
| | C208,209 | nsp | CC73CH1H330JT +1608 | | | |
| | C300 | nsp | CK73F1E104ZT +1608 | for S-52E3 | | |
| | C301 | nsp | CK73B1H102KT +1608 | for S-52E3 | | |
| | C302 | nsp | CK73F1E104ZT +1608 | | | |
| | C303 | 00D 254 4740 921 | CE67W1C470MT(GV) | | | |
| | C304 | nsp | CK73F1E104ZT +1608 | | | |
| | C305 | 00D 254 4740 976 | CE67W1C100MT(GV) | | | |
| | C306 | nsp | CK73F1E104ZT +1608 | | | |
| | C307 | 00D 254 4740 976 | CE67W1C100MT(GV) | | | |
| | C308,309 | 00D 257 0503 967 | CC73CH1H150JT +1608 | | | |
| | C310 | 00D 257 0508 988 | CC73CH1H102JT +1608 | | | |
| | C311,312 | nsp | CK73F1E104ZT +1608 | | | |
| | C313,314 | nsp | CC73CH1H120JT +1608 | | | |
| | C315 | 00D 254 4740 921 | CE67W1C470MT(GV) | | | |
| | C316 | 00D 254 4742 903 | CE67W1V4R7MT(GV) | | | |
| | C317 | nsp | CK73F1H103ZT +1608 | | | |
| | C318,319 | nsp | CK73F1E104ZT +1608 | | | |
| | C320 | 00D 254 4743 957 | CE67W1H2R2MT(GV) | | | |
| | C321 | nsp | CK73B1H102KT +1608 | | | |
| | C322 | nsp | CK73F1E104ZT +1608 | | | |
| | C323 | nsp | CK73B1H102KT +1608 | | | |
| | C324 | 00D 254 4739 916 | CE67W1A470MT(GV) | | | |

| | Ref. No. | Part No. | Part Name | Remarks | Q'ty | New |
|--|----------|------------------|---------------------------|-------------------------------|------|-----|
| | C325,326 | 00D 254 4740 976 | CE67W1C100MT(GV) | | | |
| | C327 | nsp | CC73CH1H101JT +1608 | | | |
| | C328 | nsp | CK73F1H103ZT +1608 | | | |
| | C329,330 | nsp | CK73F1E104ZT +1608 | | | |
| | C331 | nsp | CC73CH1H561JT +1608 | | | |
| | C332 | nsp | CC73CH1E681JT +1608 | | | |
| | C333 | nsp | CC73CH1H561JT +1608 | | | |
| | C334 | nsp | CC73CH1E681JT +1608 | | | |
| | C336,337 | 00D 254 4740 934 | CE67W1C101MT(GV) | | | |
| | C338,339 | nsp | CK73B1H332KT +1608 | | | |
| | C340,341 | 00D 254 4740 976 | CE67W1C100MT(GV) | for S-52E3 | | |
| | C342 | 00D 254 4740 976 | CE67W1C100MT(GV) | | | |
| | C343,344 | 00D 254 4743 957 | CE67W1H2R2MT(GV) | | | |
| | C345,346 | 00D 254 4740 976 | CE67W1C100MT(GV) | | | |
| | C347 | nsp | CC73CH1H101JT +1608 | | | |
| | C348 | nsp | CK73F1E104ZT +1608 | | | |
| | C349 | nsp | CC73CH1H101JT +1608 | | | |
| | C350 | nsp | CK73F1E104ZT +1608 | | | |
| | C351-353 | 00D 254 4740 976 | CE67W1C100MT(GV) | | | |
| | C355 | nsp | CK73B1H102KT +1608 | | | |
| | C356 | nsp | CK73B1H103KT (1608) +1608 | | | |
| | C357 | nsp | CC73CH1H221JT +1608 | | | |
| | C358 | nsp | CK73B1E104KT +1608 | | | |
| | C359 | nsp | CK73F1E104ZT +1608 | | | |
| | C362 | nsp | CK73F1E104ZT +1608 | | | |
| | C363 | nsp | CK73B1H102KT +1608 | | | |
| | C364,365 | nsp | CK73F1E104ZT +1608 | | | |
| | C366 | 00D 254 4743 944 | CE67W1H010MT(GV) | | | |
| | C367 | nsp | CK73F1E104ZT +1608 | for S-52E3/E2/DABEK,S-32E3/E2 | | |
| | C368,369 | 00D 254 4740 976 | CE67W1C100MT(GV) | | | |
| | C372-374 | nsp | CK73B1H102KT +1608 | | | |
| | C375 | nsp | CK73F1H103ZT +1608 | | | |
| | C380,381 | nsp | CK73F1E104ZT +1608 | | | |
| | C382 | nsp | CK73F1H103ZT +1608 | | | |
| | C383 | nsp | CK73B1H102KT +1608 | | | |
| | C384 | nsp | CK73F1H103ZT +1608 | for S-52E2/DABEK,S-32E2 | | |
| | C385 | nsp | CK73F1E104ZT +1608 | for S-52E2/DABEK,S-32E2 | | |
| | C386 | nsp | CK73F1H103ZT +1608 | for S-52E2/DABEK,S-32E2 | | |
| | C387 | nsp | CC73CH1H220JT +1608 | for S-52E2/DABEK,S-32E2 | | |
| | C388 | nsp | CK73F1H103ZT +1608 | for S-52E2/DABEK,S-32E2 | | |
| | C389 | nsp | CC73CH1H220JT +1608 | for S-52E2/DABEK,S-32E2 | | |
| | C390 | nsp | CK73F1H103ZT +1608 | for S-52E2/DABEK/JP,S-32E3/E2 | | |
| | C391 | nsp | CC73CH1H561JT +1608 | for S-52E2/DABEK,S-32E2 | | |
| | C392-394 | nsp | CK73F1H103ZT +1608 | for S-52E2/DABEK/JP,S-32E3/E2 | | |
| | C395 | 00D 254 4740 921 | CE67W1C470MT(GV) | for S-52E2/DABEK,S-32E2 | | |
| | C396 | 00D 254 4740 976 | CE67W1C100MT(GV) | for S-52E2,DABEK,S-32E2 | | |
| | C397 | nsp | CK73F1H103ZT +1608 | for S-52E2,DABEK,S-32E2 | | |
| | C398 | nsp | CC73CH1H331JT +1608 | for S-52E2,DABEK,S-32E2 | | |
| | C399 | nsp | CK73F1H103ZT +1608 | for S-52E2,DABEK,S-32E2 | | |
| | C400 | nsp | CK73F1E104ZT +1608 | for S-52E3 | | |
| | C401 | nsp | CK73F1H103ZT +1608 | for S-52E3 | | |
| | C402 | nsp | CK73B1H102KT +1608 | for S-52E3 | | |
| | C403 | nsp | CK73F1E104ZT +1608 | | | |
| | C404 | nsp | CK73B1H102KT +1608 | | | |
| | C405 | nsp | CK73F1H103ZT +1608 | | | |
| | C406 | nsp | CK73F1E104ZT +1608 | | | |
| | C407 | nsp | CK73B1H102KT +1608 | | | |

| | Ref. No. | Part No. | Part Name | Remarks | Q'ty | New |
|--|----------|------------------|---------------------------|------------------|------|-----|
| | C408 | nsp | CK73F1H103ZT +1608 | | | |
| | C409 | nsp | CK73F1E104ZT +1608 | | | |
| | C410 | nsp | CK73B1H102KT +1608 | | | |
| | C411 | nsp | CK73F1H103ZT +1608 | | | |
| | C412 | nsp | CK73F1E104ZT +1608 | | | |
| | C413 | nsp | CK73B1H102KT +1608 | | | |
| | C414,415 | nsp | CK73F1H103ZT +1608 | | | |
| | C501 | nsp | CK73F1H103ZT +1608 | | | |
| | C502 | nsp | CK73B1H102KT +1608 | | | |
| | C503 | nsp | CK73F1H103ZT +1608 | for S-52 | | |
| | C504 | nsp | CK73B1H102KT +1608 | for S-52 | | |
| | C505 | nsp | CK73F1E104ZT +1608 | | | |
| | C506-510 | 00D 257 0521 949 | CK73B1A474KT | | | |
| | C511-513 | nsp | CK73F1E104ZT +1608 | | | |
| | C514-517 | nsp | CK73B1H102KT +1608 | | | |
| | C700-702 | nsp | CK73B1H102KT +1608 | | | |
| | C703,704 | nsp | CK73F1E104ZT +1608 | | | |
| | C705,706 | nsp | CK73B1H102KT +1608 | | | |
| | C707 | nsp | CK73F1H103ZT +1608 | | | |
| | C708 | 00D 254 4739 916 | CE67W1A470MT(GV) | | | |
| | C709-711 | nsp | CK73F1E104ZT +1608 | | | |
| | C712 | nsp | CK73F1H103ZT +1608 | | | |
| | C714 | 00D 254 4739 916 | CE67W1A470MT(GV) | | | |
| | C716 | nsp | CK73B1H102KT +1608 | | | |
| | C717-720 | nsp | CK73F1E104ZT +1608 | | | |
| | C721,722 | 00D 254 4739 916 | CE67W1A470MT(GV) | | | |
| | C723,724 | 00D 254 4740 921 | CE67W1C470MT(GV) | | | |
| | C725 | nsp | CK73F1E104ZT +1608 | | | |
| | C726 | nsp | CK73B1H102KT +1608 | | | |
| | C727 | 00D 254 4739 916 | CE67W1A470MT(GV) | | | |
| | C728 | nsp | CK73B1H102KT +1608 | | | |
| | C729,730 | nsp | CK73F1H103ZT +1608 | | | |
| | C733 | nsp | CK73B1H102KT +1608 | | | |
| | C736 | nsp | CK73B1H102KT +1608 | | | |
| | C742,743 | nsp | CK73F1E104ZT +1608 | | | |
| | C744 | nsp | CK73B1H102KT +1608 | | | |
| | C747,748 | 00D 254 4740 976 | CE67W1C100MT(GV) | for S-52E3 | | |
| | C749 | 00D 235 0130 903 | CHIP EMIFIL(11A121) +1608 | for S-52E3 | | |
| | C751 | nsp | CK73B1H102KT +1608 | for S-52E3 | | |
| | C753 | 00D 257 0039 907 | CK73B0J106MT | for S-52E3 | | |
| | C755-758 | nsp | CC73CH1H200JT +1608 | for S-52E3 | | |
| | C759,760 | nsp | CK73B1E104KT +1608 | for S-52E3 | | |
| | C761 | 00D 254 4740 905 | CE67W1C220MT(GV) | for S-52E3 | | |
| | C762,763 | nsp | CK73B1E104KT +1608 | for S-52E3 | | |
| | C764,765 | nsp | CC73CH1H5R0CT +1608 | for S-52E3 | | |
| | C766 | nsp | CK73F1E104ZT +1608 | for S-52E3 | | |
| | C767 | nsp | CK73B1E104KT +1608 | for S-52E3 | | |
| | C768 | nsp | CK73B1H102KT +1608 | for S-52E3 | | |
| | C769 | 00D 257 0039 907 | CK73B0J106MT | for S-52E3 | | |
| | C770,771 | nsp | CK73B1E104KT +1608 | for S-52E3 | | |
| | C772,773 | nsp | CK73B1H102KT +1608 | for S-52E3 | | |
| | C774 | 00D 257 0039 907 | CK73B0J106MT | for S-52E3 | | |
| | C775 | nsp | CK73B1H102KT +1608 | for S-52E3 | | |
| | C777,778 | nsp | CK73F1E104ZT +1608 | for S-52E3 | | |
| | C789 | nsp | CK73F1E104ZT +1608 | for S-52E3/DABEK | | |
| | C790 | 00D 254 4739 916 | CE67W1A470MT(GV) | for S-52E3/DABEK | | |
| | C791,792 | nsp | CK73F1E104ZT +1608 | for S-52E3/DABEK | | |

| | Ref. No. | Part No. | Part Name | Remarks | Q'ty | New |
|--|-----------|------------------|---------------------|------------------|------|-----|
| | C793 | 00D 254 4739 916 | CE67W1A470MT(GV) | for S-52E3/DABEK | | |
| | C872-874 | nsp | CK73F1E104ZT +1608 | | | |
| | C875 | nsp | CK73F1E104ZT +1608 | for S-52DABEK | | |
| | C876,877 | nsp | CK73B1H102KT +1608 | for S-52DABEK | | |
| | CC101 | 00D 257 0039 907 | CK73B0J106MT | | | |
| | CC102,103 | nsp | CK73F1E104ZT +1608 | | | |
| | CC104 | nsp | CK73F1H103ZT +1608 | | | |
| | CC105-108 | 00D 257 5009 974 | CK73F1C104ZT +1005 | | | |
| | CC109-112 | nsp | CK73B1H102KT +1005 | | | |
| | CC113-116 | nsp | CK73B1A104KT +1005 | | | |
| | CC117-120 | nsp | CK73B1H102KT +1005 | | | |
| | CC121,122 | nsp | CC73CH1H120JT +1608 | | | |
| | CC123 | 00D 257 0039 907 | CK73B0J106MT | | | |
| | CC124 | nsp | CK73B1H102KT +1608 | | | |
| | CC125 | nsp | CK73F1E104ZT +1608 | | | |
| | CC126,127 | nsp | CK73F1H103ZT +1608 | | | |
| | CC128,129 | 00D 257 0039 907 | CK73B0J106MT | | | |
| | CC130 | nsp | CK73B1H102KT +1608 | | | |
| | CC131,132 | 00D 257 5009 974 | CK73F1C104ZT +1005 | | | |
| | CC133,134 | nsp | CK73B1H102KT +1005 | | | |
| | CC135 | nsp | CK73F1E104ZT +1608 | | | |
| | CC136-141 | 00D 257 5009 974 | CK73F1C104ZT +1005 | | | |
| | CC142,143 | nsp | CK73B1H102KT +1005 | | | |
| | CC147 | 00D 257 0011 996 | CK73B1E104KT +2125 | | | |
| | CC148-150 | nsp | CK73F1E104ZT +1608 | | | |
| | CC151-153 | nsp | CK73B1H102KT +1608 | | | |
| | CC154 | 00D 257 0039 907 | CK73B0J106MT | | | |
| | CC155 | nsp | CK73F1E104ZT +1608 | | | |
| | CC156 | 00D 254 4738 904 | CE67W0J101MT(GV) | | | |
| | CC157,158 | nsp | CK73F1E104ZT +1608 | | | |
| | CC159 | 00D 254 4740 905 | CE67W1C220MT(GV) | | | |
| | CC160 | nsp | CK73F1E104ZT +1608 | | | |
| | CC161-164 | nsp | RM73B--0R0KT +1608 | | | |
| | CC165 | nsp | CK73F1E104ZT +1608 | for S-52 | | |
| | CC166 | 00D 254 4738 904 | CE67W0J101MT(GV) | for S-52 | | |
| | CC167,168 | nsp | CK73F1E104ZT +1608 | for S-52 | | |
| | CC169 | 00D 257 0039 907 | CK73B0J106MT | for S-52 | | |
| | CC174 | 00D 254 4738 904 | CE67W0J101MT(GV) | | | |
| | CC175 | nsp | CK73F1E104ZT +1608 | | | |
| | CC176 | nsp | CK73B1H102KT +1608 | | | |
| | CC177 | nsp | CK73B1A104KT +1005 | | | |
| | CC178,179 | 00D 254 4740 921 | CE67W1C470MT(GV) | | | |
| | CC180,181 | nsp | RM73B--0R0KT +1608 | | | |
| | CC183 | nsp | CK73B1H102KT +1608 | | | |
| | CC184 | nsp | CC73CH1H101JT +1608 | | | |
| | CC185 | nsp | CK73B1H102KT +1608 | | | |
| | CC187 | nsp | CC73CH1H101JT +1608 | | | |
| | CC188 | nsp | CK73F1E104ZT +1608 | | | |
| | CC189 | nsp | CK73B1H102KT +1608 | | | |
| | CC190 | 00D 254 4740 921 | CE67W1C470MT(GV) | | | |
| | CC191 | 00D 257 0039 907 | CK73B0J106MT | | | |
| | CC192 | nsp | CC73CH1H101JT +1608 | | | |
| | CC193,194 | nsp | CK73B1E104KT +1608 | | | |
| | CC195,196 | nsp | RM73B--0R0KT +1608 | | | |
| | CC197 | nsp | CC73CH1H100DT +1608 | | | |
| | CC198-201 | 00D 257 5002 926 | CC73CH1H100DT +1005 | | | |

| Ref. No. | Part No. | Part Name | Remarks | Q'ty | New |
|---------------------------|------------------|---------------------------|-------------------------------------|------|-----|
| CC202 | nsp | CC73CH1H100DT +1608 | | | |
| CC203 | 00D 257 5002 926 | CC73CH1H100DT +1005 | | | |
| CC204 | nsp | CC73CH1H100DT +1608 | | | |
| CC205-213 | 00D 257 5002 926 | CC73CH1H100DT +1005 | | | |
| OTHERS PARTS GROUP | | | | | |
| CX051 | nsp | 5P PH CON BASE(TAPE) +REF | | | |
| CX054 | nsp | 5P PH CON BASE(TAPE) +REF | for S-52 | | |
| CX062 | nsp | 6P CONN.BASE(KR-PH) | | | |
| CX071 | nsp | 7P ZH-ZR CON.BASE-T | for S-52E3/E2/DABEK,S-32E3/E2 | | |
| CX081 | nsp | 8P PH CON.BASE(TAPE) | for S-52DABEK | | |
| CX091 | nsp | 9P CONN.BASE(KR-PH) | | | |
| CX101 | nsp | 10P ZR CON. BASE(L) | | | |
| CX111 | nsp | 11P PH CON.BASE(TAPE) | | | |
| CX124 | nsp | MINI-PCI-CONNECTOR | | | * |
| CX131 | nsp | 13P KR CON BASE(L) | | | |
| CX151 | nsp | 15P FFC CON.BASE | for S-52E2/DABEK/JP,S-32E3/E2 | | |
| CX161 | nsp | 16P PHD BASE | for S-52E3 | | |
| CX262 | nsp | 26P FFC BASE(9639S) | | | * |
| CX301 | nsp | 30P-FFC-BASE(9610SC) | for S-52 | | |
| CX303 | nsp | 3P ZH-ZR CON.BASE-T | | | |
| CX109 | nsp | 10P FFC BASE(9610SA) | for S-32E3/E2 | | |
| CY064 | nsp | 6P ZH-ZR CON.BASE-T | | | |
| CY071 | nsp | 7P ZH-ZR CON.BASE-T | for S-52E3/E2/DABEK,S-32E3/E2 | | |
| FB101 | 00D 235 0158 901 | CHIP BEADS(18PG121) +1608 | | | |
| FB102-104 | nsp | RM73B--0R0KT +2125 | | | |
| FB303,304 | 00D 235 0130 903 | CHIP EMIFIL(11A121) +1608 | for S-52E3 | | |
| FB307,308 | 00D 235 0147 909 | E.FIL(BLM21PG221SN1)+2125 | for S-52E2/DABEK/JP,S-32E3/E2 | | |
| FB501-506 | 00D 235 0130 903 | CHIP EMIFIL(11A121) +1608 | | | |
| FB701,702 | 00D 235 0130 903 | CHIP EMIFIL(11A121) +1608 | | | |
| FB703,704 | 00D 235 0147 909 | E.FIL(BLM21PG221SN1)+2125 | for S-52E3 | | |
| JK011 | 00D 204 8604 000 | 1P PIN JACK(S-GND) | | | |
| JK012 | 00D 204 8637 006 | MINI JACK (STEREO) | | | |
| JK071 | 00D 205 1362 009 | XM/DT BUS CONNECTOR | for S-52E3 | | |
| JK081 | 00D 205 1135 003 | 8P MD BASE (F-S) | for S-52E3 | | |
| JK501 | 00D 205 1333 009 | 8P MODULAR | | | |
| ST301 | nsp | STYLE PIN | | | |
| ST501,502 | nsp | STYLE PIN | | | |
| W301 | nsp | 1P SIN-EH CON CORD | | | * |
| W701 | nsp | M3 SCREW TERMINAL | | | |
| X301 | 00D 399 0988 909 | X'TAL (12.288MHZ) | | | |
| X302 | 00D 399 1031 907 | XTAL(11.2896M/SMT) | | | |
| X303 | 00D 399 1009 007 | X-TAL(S-4.332-14) | for S-52E2/DABEK,S-32E2 | | |
| X501 | 00D 399 1030 908 | HC-49/U03C24.576MHZ | | | |
| X701 | 00D 399 1055 909 | FCX-02(45.1584MHz) | for S-52E3 | | |
| X702 | 00D 399 1090 906 | CSTCW24M0X51R-R0 | | | |
| | nsp | 7P ZH-ZH CON.CORD | for CX071:S-52E3/E2/DABEK,S-32E3/E2 | | * |

1U-3847 POWER AMP/KEY P.W.B. UNIT ASS'Y

| Ref. No. | Part No. | Part Name | Remarks | Q'ty | New |
|-----------------------------|------------------|---------------------------|---------------|------|-----|
| SEMICONDUCTORS GROUP | | | | | |
| IC107 | 00D 399 1126 003 | GP1UE261XKVF | | | * |
| TR105,106 | 00D 269 0192 902 | KRC102S-RTK/P (10K-10K) | | | |
| ZD102 | 00D 276 0683 943 | UDZS3.6B-TE17 | | | |
| LD101,102 | 00D 393 9663 007 | SLR-343MG3F(GREEN) | | | |
| CAPACITORS GROUP | | | | | |
| C101 | nsp | CK73F1E104ZT +1608 | | | |
| C102 | nsp | CK73B1H103KT (1608) +1608 | | | |
| C103 | nsp | CK73F1E104ZT +1608 | | | |
| C104 | nsp | CK73B1H103KT (1608) +1608 | | | |
| C198,199 | nsp | CK73F1E104ZT +1608 | | | |
| C201 | nsp | CK73F1E104ZT +1608 | | | |
| C202 | nsp | CK73B1H103KT (1608) +1608 | | | |
| C203 | nsp | CK73F1E104ZT +1608 | | | |
| C204 | nsp | CK73B1H103KT (1608) +1608 | | | |
| C206 | nsp | CK73F1E104ZT +1608 | | | |
| C207 | nsp | CK73B1H103KT (1608) +1608 | | | |
| C208 | 00D 254 4816 907 | CE04W0J101MTD(SRE) | | | * |
| C209-212 | nsp | CK73F1H103ZT +1608 | | | |
| C213 | nsp | CK73F1E104ZT +1608 | | | |
| C215 | nsp | CK73F1E104ZT +1608 | | | |
| C216 | nsp | CK73B1H103KT (1608) +1608 | | | |
| C217-220 | nsp | CK73F1E104ZT +1608 | | | |
| C225 | nsp | CK73F1E104ZT +1608 | | | |
| C227 | nsp | CK73F1H103ZT +1608 | | | |
| C228 | nsp | CK73F1E104ZT +1608 | | | |
| C235 | 00D 254 4733 909 | CE04W1A100MT(SF) | | | |
| C300 | nsp | CK73F1E104ZT +1608 | for S-52DABEK | | |
| C301 | nsp | CK73F1H103ZT +1608 | for S-52DABEK | | |
| C302 | nsp | CK73F1E104ZT +1608 | for S-52DABEK | | |
| C304,305 | nsp | CK73F1H103ZT +1608 | for S-52DABEK | | |
| C307 | nsp | CK73F1E104ZT +1608 | for S-52DABEK | | |
| C308,309 | 00D 254 4818 002 | CE04W0J331M F11(KY) | for S-52DABEK | | * |
| OTHERS PARTS GROUP | | | | | |
| CW101 | nsp | 10P ZH-JB CON.CORD | | | * |
| CX032 | nsp | 3P ZH-SAN CON.CORD | | | * |
| CX045 | nsp | 4P PWB HEADER | for S-52DABEK | | * |
| CX201 | nsp | 20P PWB HEADER | for S-52DABEK | | * |
| CY063 | nsp | 6P ZR CON.BASE (L) | | | |
| CY081 | nsp | 8P KR CON BASE(L) | for S-52DABEK | | |
| CY091 | nsp | 9P CONN.BASE(KR-PH) | | | |
| FB101-105 | 00D 235 0130 903 | CHIP EMIFIL(11A121) +1608 | | | |
| FB201,202 | 00D 235 0158 901 | CHIP BEADS(18PG121) +1608 | for S-52DABEK | | |
| JK101 | 00D 204 8637 006 | MINI JACK (STEREO) | | | |

| Ref. No. | Part No. | Part Name | Remarks | Q'ty | New |
|-----------|------------------|----------------------|-----------|------|-----|
| JK102 | 00D 204 8424 002 | H/PHONE JACK | | | |
| S101-113 | 00D 212 5604 907 | TACT SWITCH-TA(ALPS) | | | * |
| S114 | 00D 212 1209 005 | PUSH SWITCH | | | * |
| S115 | 00D 212 0529 003 | ROTARY ENCODER | | | * |
| S116 | 00D 212 1209 005 | PUSH SWITCH | | | * |
| ST101,102 | - | OPEN | | | |
| SY101 | 00D 279 0034 067 | PTH9M04BB222TS2F333 | | | |
| | nsp | PVC TUBE (L=5) | for SY101 | | |

1U-3859 POWER /IPOD UNIT P.W.B. UNIT ASS'Y

| Ref. No. | Part No. | Part Name | Remarks | Q'ty | New |
|-----------------------------|------------------|---------------------------|-------------------------------|------|-----|
| SEMICONDUCTORS GROUP | | | | | |
| IC100 | 00D 263 1100 021 | KIA7812API-U/P | | | |
| IC101-103 | 00D 263 1219 006 | BD9702T-V5 | | | |
| IC108 | 00D 263 1223 005 | PQ20RX11J00H | for S-52E3/DABEK | | |
| IC306 | 00D 262 2977 946 | BA33BC0FP-E2 +REF | | | |
| IC505 | 00D 262 3763 007 | TA8216HQ(5) | | | * |
| TR300 | 00D 273 0464 901 | KTC3875S-GR-RTK/P | | | |
| TR302 | 00D 273 0464 901 | KTC3875S-GR-RTK/P | | | |
| TR320,321 | 00D 273 0460 905 | KTC2875-B-RTK/P | | | |
| TR322 | 00D 269 0184 907 | KRA102S-RTK/P (10K-10K) | | | |
| TR323 | 00D 269 0192 902 | KRC102S-RTK/P (10K-10K) | | | |
| TR501 | 00D 273 0460 905 | KTC2875-B-RTK/P | | | |
| D100-111 | 00D 276 0772 003 | 1N4004 | | | |
| D112-114 | 00D 276 0857 902 | RB050LA-40 | | | * |
| D201-205 | 00D 276 0794 900 | KDS160-RTK/P | | | |
| D208 | 00D 276 0772 003 | 1N4004 | | | |
| D314 | 00D 276 0750 902 | RB521S-30TE61 +REF | | | |
| D315 | 00D 276 0401 905 | 1SS133T77 (TAPE) | | | |
| D316-323 | 00D 276 0750 902 | RB521S-30TE61 +REF | | | |
| ZD101 | 00D 276 0837 906 | NSAD500F-T1B-A | for S-52 | | |
| ZD102 | nsp | RM73B--0R0KT +2125 | | | |
| RESISTORS GROUP | | | | | |
| R515,516 | 00D 241 2171 907 | RD14B2H4R7JT | | | |
| R102 | 00D 247 2024 913 | RM73B--6041DT (1608) | for S-52E3 | | |
| R102 | 00D 247 2009 983 | RM73B--103JT +1608 | for S-52E2/DABEK/JP,S-32E3/E2 | | |
| R103 | 00D 247 2021 903 | RM73B--122FT +1608 | for S-52E3 | | |
| R103 | 00D 247 2008 997 | RM73B--432JT +1608 | for S-52E2/DABEK/JP,S-32E3/E2 | | |
| CAPACITORS GROUP | | | | | |
| C100-111 | nsp | CK73F1H103ZT +1608 | | | |
| C112 | 00D 254 6279 005 | CE68W1H222M(SMHP25S) | | | * |
| C114 | 00D 254 4428 706 | CE04W1V222MC (SMG) | | | |
| C115 | 00D 254 4523 724 | CE04W1V472MC SMG/RE3 | | | |
| C116 | nsp | CK73F1H103ZT +1608 | | | |
| C118,119 | nsp | CK73F1H103ZT +1608 | | | |
| C121-123 | nsp | CK73B1H103KT (1608) +1608 | | | |
| C124-127 | nsp | CK73F1E104ZT +1608 | | | |
| C128 | nsp | CK73B1E104KT +1608 | | | |
| C129 | 00D 254 4694 912 | CE04W1E221MT(RF0) | | | |
| C130 | nsp | CK73F1E104ZT +1608 | | | |
| C132 | 00D 247 2024 913 | RM73B--6041DT (1608) | for S-52E3 | | |
| C134-136 | nsp | CK73B1H103KT (1608) +1608 | | | |
| C137 | nsp | CK73B1E104KT +1608 | for S-52E3/DABEK | | |
| C138-140 | 00D 254 4708 905 | CE04W1E221MT HB5(KY) | | | |
| C141 | 00D 254 4536 915 | CE04W1A470MT SMG/RE3 | for S-52E3/DABEK | | |
| C142 | nsp | CK73F1E104ZT +1608 | | | |
| C143-145 | nsp | CK73B1E104KT +1608 | | | |
| C146 | nsp | CK73F1H103ZT +1608 | | | |

③
③
③
③

③

| | Ref. No. | Part No. | Part Name | Remarks | Q'ty | New |
|---------------------------|----------|------------------|----------------------|----------------------------|------|-----|
| | C147-149 | 00D 254 4708 905 | CE04W1E221MT HB5(KY) | | | |
| | C150 | nsp | CK73F1H103ZT +1608 | | | |
| | C200 | 00D 254 4533 934 | CE04W0J221MT SMG/RE3 | for S-52 | | |
| | C201-203 | nsp | CK73F1E104ZT +1608 | for S-52 | | |
| | C206 | nsp | CK73F1E104ZT +1608 | | | |
| | C207 | nsp | CK73B1H102KT +1608 | | | |
| | C208 | nsp | CK73F1E104ZT +1608 | | | |
| | C209 | nsp | CK73B1H102KT +1608 | | | |
| | C210 | nsp | CK73F1E104ZT +1608 | | | |
| | C211 | nsp | CK73B1H102KT +1608 | | | |
| | C212,213 | nsp | CK73F1E104ZT +1608 | | | |
| | C301 | nsp | CK73B1E104KT +1608 | | | |
| | C302 | 00D 254 4539 705 | CE04W1C102MC SMG/RE3 | | | |
| | C303-306 | nsp | CK73F1H103ZT +1608 | | | |
| | C342 | 00D 253 8022 710 | CK45F2EAC222MC | | | |
| | C346 | 00D 253 8022 710 | CK45F2EAC222MC | for S-52E2/DABEK/JP,S-32E2 | | |
| | C350 | 00D 253 8022 710 | CK45F2EAC222MC | | | |
| | C362 | 00D 254 4718 995 | CE04W1C222MT(GR) | | | |
| | C363 | nsp | CK73B1H102KT +1608 | | | |
| | C365 | nsp | CK73F1E104ZT +1608 | | | |
| | C366 | 00D 254 4717 912 | CE04W1A470MT(GR) | | | |
| | C505 | 00D 253 1201 907 | CK45F1H103ZT(H) | | | |
| | C554,555 | 00D 254 4718 940 | CE04W1C101MT(GR) | | | |
| | C556,557 | 00D 257 0508 920 | CC73CH1H511JT +1608 | | | |
| | C564 | 00D 254 4718 940 | CE04W1C101MT(GR) | | | |
| | C567 | 00D 254 4717 941 | CE04W1A331MT(GR) | | | |
| | C568 | 00D 254 4569 717 | CE04W1E222MC(RA3) | | | |
| | C570 | 00D 254 4569 717 | CE04W1E222MC(RA3) | | | |
| | C571-573 | 00D 256 1058 971 | CF93A1H104JT (JL) | | | |
| OTHERS PARTS GROUP | | | | | | |
| | AS101 | nsp | RADIATOR | | | |
| | AS108 | nsp | RADIATOR | for S-52E3/DABEK | | |
| | CX021 | nsp | 2P EH CONNECTOR BASE | | | |
| | CX041 | nsp | 4P CONN.BASE(KR-PH) | | | |
| | CX051 | nsp | 5P KR CON BASE(L) | | | |
| | CX063 | nsp | 6P EH CONNECTOR BASE | | | |
| △ | CX121 | 00D 203 3905 002 | YKE31-0149N | for S-52E3,S-32E3 | | |
| △ | CX121 | 00D 203 3905 015 | YKE31-0148N | for S-52E2/DABEK/JP,S-32E2 | | |
| △ | CX122 | nsp | 2P VH CONN. BASE (L) | | | |
| | CX131 | nsp | 13P KR CON BASE(L) | | | |
| | CX302 | 00D 205 1451 004 | DOCK CON.(514S0117) | | | |
| | CY041 | nsp | 4P CONN.BASE(KR-PH) | | | |
| | CY042 | nsp | 4P VH CON.BASE | | | |
| | CY051 | nsp | 5P CONN.BASE(KR-PH) | for S-52 | | |
| | CY061 | nsp | 6P CONN.BASE(KR-PH) | for S-52 | | |
| | CY062 | nsp | 6P CONN.BASE(KR-PH) | | | |
| | CY111 | nsp | 11P CON.BASE(KR-PH) | | | |
| △ | F100,101 | 052 010 0120 010 | # FUSE T1.25AL/250V | | | |
| △ | F102 | 652 010 0220 02S | 021802.5MXP | | | |
| △ | F103 | 00D 206 1039 050 | FUSE 1.6A T | for S-52E3,S-32E3 | | |
| △ | F103 | 00D 206 1015 029 | FUSE 1A T | for S-52E2,S-32E3 | | |

| | Ref. No. | Part No. | Part Name | Remarks | Q'ty | New |
|---|-----------|------------------|------------------------------|----------------------------------|------|-----|
| △ | F103 | 00D 206 1015 029 | FUSE 1A T | for S-52DABEK | | |
| △ | F103 | 00D 206 1035 054 | FUSE 1.6A (T) | for S-52JP | | |
| | FB100 | 00D 235 0147 909 | E.FIL(BLM21PG221SN1)+2125 | for S-52 | | |
| △ | FF100-103 | nsp | FUSE CLIP(TAPE) | | | |
| △ | FH100-103 | nsp | FUSE CLIP(TAPE) | | | |
| | JK103 | 00D 204 8714 000 | USB CONNECTOR(TOPYANG BLACK) | for S-52 | | |
| | JK203 | 00D 205 1344 001 | 1P F TERMINAL | for S-52DABEK | | |
| | JK204 | 00M YJ0 7000 350 | CO-AX CABLE MINIJACK | for S-52DABEK | | |
| | L100-102 | 00D 235 0193 005 | LHL13TB470K | | | |
| △ | L103-105 | 00D 235 0142 920 | COIL LHL08TB100KT | | | |
| | L401 | 00D 235 0157 009 | PLA10AN7720R7D2B | | | |
| △ | RL201 | 00D 214 0224 003 | RELAY(0JT-SS-109LM) | | | |
| | ST101 | nsp | STYLE PIN | | | |
| | ST102 | nsp | STYLE PIN | for S-52 | | |
| | ST301 | nsp | STYLE PIN | for S-52 | | |
| | ST502 | nsp | STYLE PIN | | | |
| | SY101 | nsp | HEAT SINK | | | |
| △ | T200 | 00D 233 6613 004 | POWER TRANS(SUB/E3) | for S-52E3,S-32E3 | | * |
| △ | T200 | 00D 233 6565 000 | POWER TRANS(SUB/E2) | for S-52E2/DABEK/S-32E2 | | |
| △ | T200 | 00D 233 0719 001 | POWER TRANS(SUB/J) | for S-52JP | | |
| | | nsp | 3X16 CPTS(B) SW W | | | |
| | | nsp | 3X8 CPS(SW,W) ZNP | | | |
| | | nsp | SHIELD CASE (A) | for S-52DABEK | | |
| | | nsp | SHIELD CASE (B) | for S-52DABEK | | |
| △ | | nsp | FUSE COVER | for F103 | | |
| | | nsp | FUSE LABEL | for F103:S-52E2/DABEK,S-32E2 | | |
| △ | | nsp | CONDENSER COVER | for C342 | | * |
| △ | | nsp | CONDENSER COVER | for C346 | | * |
| △ | | nsp | CONDENSER COVER | for S-52E2/DABEK/JP,S-32E2 :C350 | | * |

EXPLODED VIEW

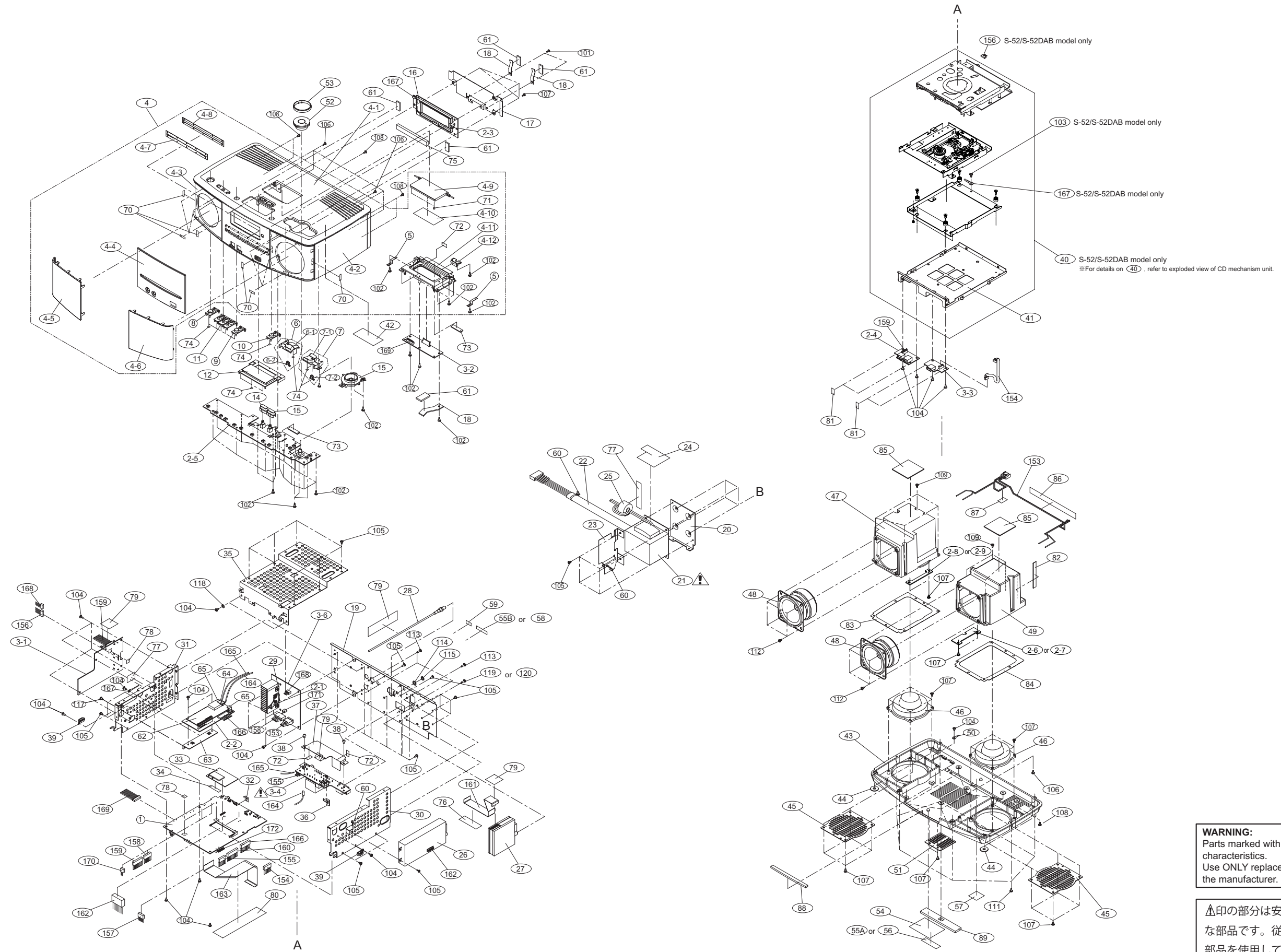

PARTS LIST OF EXPLODED VIEW

* 本表に "nsp" と記載されている部品は供給できません。

* Parts for which "nsp" is indicated on this table cannot be supplied.

* 本表に "nsp" と記載されている基板 ASS'Y は供給できません。基板 ASS'Y の修理の際には基板部品表を確認のうえ、交換部品を発注してください。

* P.W.B. ASS'Y for which "nsp" is indicated on this table cannot be supplied. When repairing the P.W.B. ASS'Y, check the board parts table and order replacement parts.

* 本表に記載されている部品は、補修用部品のため製品に使用している部品とは一部、形状、寸法などが異なる場合があります。

* The parts listed below are for maintenance only, might differ from the parts used in the unit in appearances or dimensions.

Note: The symbols in the column "Remarks" indicate the following destinations.

E3 : U.S.A. & Canada model

E2 : Europe model

EK : U.K. model







JP : Japan mode

SR : Silver model

WT : White model

| Ref. No. | Part No. | Part Name | Remarks | Q'ty | New |
|----------|--------------|----------------------------|-----------------------------|------|-----|
| 1 | 00D1U-3846A | MAIN UNIT (E3) | for S-52E3 | 1 | * |
| 1 | 00D1U-3846B | MAIN UNIT (E2) | for S-52E2 | 1 | * |
| 1 | 00D1U-3846C | MAIN UNIT (EK) | for S-52DABEK | 1 | * |
| 1 | 00D1U-3846D | MAIN UNIT (J) | for S-52JP | 1 | * |
| 1 | 00D1U-3846E | MAIN UNIT (E3) | for S-32E3 | 1 | * |
| 1 | 00D1U-3846F | MAIN UNIT (E2) | for S-32E2 | 1 | * |
| 2 | nsp | POWER AMP/KEY UNIT | for S-52E2/E3/JP : 1U-3847A | 1 | * |
| 2 | nsp | POWER AMP/KEY UNIT (EK) | for S-52DABEK : 1U-3847B | 1 | * |
| 2 | nsp | POWER AMP/KEY UNIT | for S-32E3/E2 : 1U-3847C | 1 | * |
| 2-1 | - | SENSOR UNIT | | 1 | |
| 2-2 | - | DAB INTERFACE UNIT | | 1 | |
| 2-3 | - | REMO/LCD UNIT | | 1 | |
| 2-4 | - | H/P PORTABLE IN UNIT | | 1 | |
| 2-5 | - | KEY UNIT | | 1 | |
| 2-6 | - | WIRE HOLDER UNIT | | 1 | |
| 2-7 | - | WIRE HOLDER UNIT | | 1 | |
| 2-8 | - | WIRE HOLDER UNIT | | 1 | |
| 2-9 | - | WIRE HOLDER UNIT | | 1 | |
| 3 | nsp | POWER /IPOD UNIT (E3) | for S-52E3 : 1U-3859A | 1 | * |
| 3 | nsp | POWER /IPOD UNIT (E2) (EK) | for S-52E2 : 1U-3859B | 1 | * |
| 3 | nsp | POWER /IPOD UNIT (J) | for S-52JP : 1U-3859C | 1 | * |
| 3 | nsp | POWER /IPOD UNIT (E3) | for S-32E3 : 1U-3859D | 1 | * |
| 3 | nsp | POWER /IPOD UNIT (E2) | for S-32E2 : 1U-3859E | 1 | * |
| 3 | nsp | POWER /IPOD UNIT (EK) | for S-52DABEK : 1U-3859F | 1 | * |
| 3-1 | - | POWER UNIT | | 1 | |
| 3-2 | - | IPOD I/O UNIT | | 1 | |
| 3-3 | - | USB TERM. UNIT | | 1 | |
| 3-4 | - | STANDBY TRANS UNIT | | 1 | |
| 3-6 | - | POWER AMP UNIT | | 1 | |
| 4 | 00DGEN8712 | CABINET (E2) ASSY | for S-52SRE2 | 1 | * |
| 4 | 00DGEN8712-1 | CABINET (E3) ASSY | for S-52SRE3 | 1 | * |
| 4 | 00DGEN8712-2 | CABINET (EK) ASSY | for S-52DABSREK | 1 | * |
| 4 | 00DGEN8712-3 | CABINET (J) ASSY | for S-52SRJP | 1 | * |
| 4 | 00DGEN8712-4 | CABINET (WE2) ASSY | for S-52WTE2 | 1 | * |
| 4 | 00DGEN8712-5 | CABINET (WE3) ASSY | for S-52WTE3 | 1 | * |
| 4 | 00DGEN8712-7 | CABINET (WJP) ASSY | for S-52WTJP | 1 | * |
| 4 | 00DGEN8713 | CABINET (E2) ASSY | for S-32E2 | 1 | * |
| 4 | 00DGEN8713-1 | CABINET (E3) ASSY | for S-32E3 | 1 | * |
| 4-1 | - | CABINET ASSY | for S-52SRE3 | 1 | * |
| 4-1 | - | CABINET ASSY | for S-52SRE2 | 1 | * |
| 4-1 | - | CABINET ASSY | for S-52DABSREK | 1 | * |
| 4-1 | - | CABINET ASSY | for S-52SRJP | 1 | * |
| 4-1 | - | CABINET ASSY | for S-52WTE3 | 1 | * |
| 4-1 | - | CABINET ASSY | for S-52WTE2 | 1 | * |
| 4-1 | - | CABINET ASSY | for S-52WTJP | 1 | * |
| 4-1 | - | CABINET ASSY | for S-32E2 | 1 | * |
| 4-1 | - | CABINET ASSY | for S-32E3 | 1 | * |

| Ref. No. | Part No. | Part Name | Remarks | Q'ty | New |
|----------|------------------|-------------------|-----------------|------|-----|
| 4-2 | - | CABINET | for S-52SR | 1 | * |
| 4-2 | - | CABINET | for S-52WT | 1 | * |
| 4-2 | - | CABINET | for S-32 | 1 | * |
| 4-3 | - | FRONT CABINET | for S-52SR | 1 | * |
| 4-3 | - | FRONT CABINET | for S-52WT | 1 | * |
| 4-3 | - | FRONT CABINET | for S-32 | 1 | * |
| 4-4 | - | WINDOW | for S-52E2 | 1 | * |
| 4-4 | - | WINDOW | for S-52E3 | 1 | * |
| 4-4 | - | WINDOW | for S-52DABEK | 1 | * |
| 4-4 | - | WINDOW | for S-52JP | 1 | * |
| 4-4 | - | WINDOW | for S-32E2 | 1 | * |
| 4-4 | - | WINDOW | for S-32E3 | 1 | * |
| 4-5 | - | METAL NET (L) | for S-52SR,S-32 | 1 | * |
| 4-5 | - | METAL NET (L) | for S-52WT | 1 | * |
| 4-6 | - | MATAL NET (R) | for S-52SR,S-32 | 1 | * |
| 4-6 | - | MATAL NET (R) | for S-52WT | 1 | * |
| 4-7 | - | BLIND SHEET | | 1 | * |
| 4-8 | - | SUPPORT SHEET | | 1 | * |
| 4-9 | - | DOCK LID ASSY | for S-52SR,S-32 | 1 | * |
| 4-9 | - | DOCK LID ASSY | for S-52WT | 1 | * |
| 4-10 | - | DOC LID COVER | for S-52SR,S-32 | 1 | * |
| 4-10 | - | DOC LID COVER | for S-52WT | 1 | * |
| 4-11 | - | DOCK ESC | for S-52SR,S-32 | 1 | * |
| 4-11 | - | DOCK ESC | for S-52WT | 1 | * |
| 4-12 | - | ADAPTER SPRING | for S-52SR,S-32 | 1 | * |
| 4-12 | - | ADAPTER SPRING | for S-52WT | 1 | * |
| 5 | 00D 463 0978 100 | SPRING PLATE | | 2 | * |
| 6 | 00D 113 2109 302 | KNOB(2P) A ASSY | for S-52SR,S-32 | 1 | * |
| 6 | 00D 113 2109 315 | KNOB(2P) A ASSY | for S-52WT | 1 | * |
| 6-1 | - | KNOB(2P) A BASE | for S-52SR,S-32 | 1 | * |
| 6-1 | - | KNOB(2P) A BASE | for S-52WT | 1 | * |
| 6-2 | - | LED LENS | | 1 | * |
| 7 | 00D 113 2108 303 | KNOB(2P) B ASSY | for S-52SR,S-32 | 1 | * |
| 7 | 00D 113 2108 316 | KNOB(2P) B ASSY | for S-52WT | 1 | * |
| 7-1 | - | KNOB(2P) B BASE | for S-52SR,S-32 | 1 | * |
| 7-1 | - | KNOB(2P) B BASE | for S-52WT | 1 | * |
| 7-2 | - | LED LENS | | 1 | * |
| 8 | 00D 113 2104 103 | KNOB (ON/STBY) | for S-52SR,S-32 | 1 | * |
| 8 | 00D 113 2104 116 | KNOB (ON/STBY) | for S-52WT | 1 | * |
| 9 | 00D 113 2105 005 | KNOB (EJECT) | for S-52SR | 1 | * |
| 9 | 00D 113 2105 021 | KNOB (EJECT) | for S-52WT | 1 | * |
| 9 | 00D 113 2105 018 | KNOB (EJECT) | for S-32 | 1 | * |
| 10 | 00D 113 2106 208 | KNOB(PLAY) | for S-52SR,S-32 | 1 | * |
| 10 | 00D 113 2106 211 | KNOB(PLAY) | for S-52WT | 1 | * |
| 11 | 00D 113 2111 109 | KNOB (3P) | for S-52SR,S-32 | 1 | * |
| 11 | 00D 113 2111 112 | KNOB (3P) | for S-52WT | 1 | * |
| 12 | 00D 113 2112 302 | KNOB (SNOOZE) | for S-52SR,S-32 | 1 | * |
| 12 | 00D 113 2112 315 | KNOB (SNOOZE) | for S-52WT | 1 | * |
| 13 | 00D 443 1625 209 | ROTARY KNOB GUIDE | | 1 | * |
| 14 | 00D 113 2126 000 | KNOB (ALARM) | for S-52SR,S-32 | 1 | * |
| 14 | 00D 113 2126 026 | KNOB (ALARM) | for S-52WT | 1 | * |
| 15 | 00D 113 2126 013 | KNOB (ALARM) | for S-52SR,S-32 | 1 | * |
| 15 | 00D 113 2126 039 | KNOB (ALARM) | for S-52WT | 1 | * |
| 16 | 00D 393 6029 107 | LCD(MDG24EC18-FJ) | | 1 | * |
| 17 | nsp | SHIELD PLATE | | 1 | * |
| 18 | nsp | EARTH PLATE | | 3 | * |

| | Ref. No. | Part No. | Part Name | Remarks | Q'ty | New |
|---|----------|------------------|--|-------------------------|------|-----|
| | 19 | 00D 105 1695 201 | REAR PANEL | for S-52SRE3 | 1 | * |
| | 19 | 00D 105 1695 214 | REAR PANEL | for S-52SRE2 | 1 | * |
| | 19 | 00D 105 1695 227 | REAR PANEL | for S-52DABSREK | 1 | * |
| | 19 | 00D 105 1695 243 | REAR PANEL | for S-32E2 | 1 | * |
| | 19 | 00D 105 1695 256 | REAR PANEL | for S-32E3 | 1 | * |
| | 19 | 00D 105 1695 269 | REAR PANEL | for S-52SRJP | 1 | * |
| | 19 | 406 310 0250 07D | REAR PANEL | for S-52WTE3 | 1 | * |
| | 19 | 406 310 0250 14D | REAR PANEL | for S-52WTE2 | 1 | * |
| | 19 | 406 310 0250 38D | REAR PANEL | for S-52WTJP | 1 | * |
| | 20 | nsp | TRANS BRACKET | | 1 | * |
| △ | 21 | 00D 233 6611 006 | POWER TRANS(MAIN/E2) | for S-52E2/DABEK,S-32E2 | 1 | * |
| △ | 21 | 00D 233 6612 005 | POWER TRANS(MAIN/E3) | for S-52E3,S-32E3 | 1 | * |
| △ | 21 | 00D 233 0746 003 | POWER TRANS(MAIN/J) | for S-52JP | 1 | * |
| | 22 | nsp | UL TUBE (12.7) BK | | 1 | * |
| | 23 | nsp | TRANS SHIELD | | 1 | * |
| | 24 | nsp | TRANS COVER | | 1 | * |
| | 25 | 00D 342 0043 000 | FERRITE CLAMP102010N | | 1 | * |
| | 26 | 00D 216 0134 005 | HD TUNER(E3) | for S-52E3 | 1 | * |
| | 27 | 00D 216 0125 001 | AM FM TUNER(E2)  | for S-52E2/DABEK,S-32E2 | 1 | * |
| | 27 | 00D 216 0125 108 | or FM AM TUNER (E2)  | for S-52E2/DABEK,S-32E2 | 1 | * |
| | 27 | 00D 216 0127 009 | AM FM TUNER(J)  | for S-52JP | 1 | * |
| | 27 | 00D 216 0127 106 | or FM AM TUNER (J)  | for S-52JP | 1 | * |
| | 27 | 00D 216 0129 007 | AM FM TUNER(E3 RDBS)  | for S-32E3 | 1 | * |
| | 27 | 00D 216 0129 104 | or FM AM TUNER (E3RDBS)  | for S-32E3 | 1 | * |
| | 28 | nsp | ANNTENA CABLE | | 1 | * |
| | 29 | nsp | HEAT SINK BRACKET | | 1 | * |
| | 30 | nsp | SIDE BRACKET (R) | | 1 | * |
| | 31 | nsp | SIDE BRACKET (L) | | 1 | * |
| | 32 | nsp | EARTH PLATE (REAR) | | 1 | * |
| | 33 | 00D 399 1099 004 | WLAN MODULE(11CH) | for S-52E3,S-32E3 | 1 | * |
| | 33 | 00D 399 1100 003 | WLAN MODULE(13CH) | | 1 | * |
| | 34 | nsp | FFC ID SUB ASSY | for S-52E3,S-32E3 | 1 | * |
| | 35 | nsp | TOP BRACKET | | 1 | * |
| | 36 | nsp | PWB BRACKET | | 1 | * |
| | 37 | nsp | PROTECTION SHEET | | 1 | * |
| | 38 | nsp | PUSH RIVET | | 2 | * |
| | 39 | nsp | CORD HOLDER | | 2 | * |
| | 40 | FGDVS202MS | CD MECHA UNIT | for S-52 | 1 | * |
| | 41 | nsp | MAIN CHASSIS | for S-32 | 1 | * |
| | 42 | nsp | E2 LASER CAUTION | for S-52E2/DABEK | 1 | * |
| | 42 | nsp | LABEL(A) | for S-52E3 | 1 | * |
| | 43 | nsp | BOTTOM COVER | for S-52SR,S-32 | 1 | * |
| | 43 | nsp | BOTTOM COVER | for S-52WT | 1 | * |
| | 44 | 00D 461 1066 002 | FELT | | 4 | * |
| | 45 | nsp | DRONE CONE COVER | for S-52SR,S-32 | 2 | * |
| | 45 | nsp | DRONE CONE COVER | for S-52WT | 2 | * |
| | 46 | 00D 305 0051 103 | PR-06 PASSIVE RADIATOR | | 2 | * |
| | 47 | nsp | SP BOX (L) | | 1 | * |
| | 48 | 00D 301 0180 001 | 77RG15 SPAEKER ASSY | | 2 | * |
| | 49 | nsp | SP BOX (R) | | 1 | * |
| | 50 | nsp | CORD HOLDER | | 1 | * |
| | 51 | nsp | COVER PLATE | for S-52SR,S-32 | 1 | * |
| | 51 | nsp | COVER PLATE | for S-52WT | 1 | * |
| | 52 | 00D 112 1012 109 | ROTARY KNOB | for S-52SR,S-32 | 1 | * |
| | 52 | 00D 112 1012 112 | ROTARY KNOB | for S-52WT | 1 | * |
| | 53 | 854 241 0001 00D | KNOB RING SUB ASSY | | 1 | * |

| Ref. No. | Part No. | Part Name | Remarks | Q'ty | New |
|---------------|------------------|----------------------|-------------------|------|-----|
| 54 | nsp | RATING SHEET | for S-52SRE2 | 1 | * |
| 54 | nsp | RATING SHEET | for S-52SRE3 | 1 | * |
| 54 | nsp | RATING SHEET | for S-52DABSREK | 1 | * |
| ★ 55A | nsp | NO. SHEET | for S-52E2/DABEK | 1 | |
| ★ 55A | nsp | NO. SHEET | for S-32E2 | 1 | |
| ★ 55B | nsp | NO. SHEET | for S-52JP | | |
| ★ 56 | nsp | SERIAL NO. SHEET | for S-52E3,S-32E3 | 1 | |
| ★ 57 | nsp | DANGEROUS LABEL | for S-52E3,S-32E3 | 1 | |
| ★ 58 | nsp | DATE LABEL | for S-52E3 | 1 | |
| ★ 59 | nsp | MANUFAC.(J)SUB ASSY | for S-52JP | 1 | |
| ★ 60 | nsp | WIRE CLAMPER | | 8 | |
| 61 | nsp | EMIGASKET RFSG020210 | 10mm | 5 | |
| 62 | 00D 216 0135 004 | DAB TUNER(VENCE4.2) | for S-52DABEK | 1 | |
| 63 | nsp | DAB PWB BRACKET | for S-52DABEK | 1 | |
| 64 | nsp | SHIELD CASE (DAB) | for S-52DABEK | 1 | |
| 65 | nsp | PWB HOLDER | for S-52DABEK | 2 | |
| 70 | nsp | SP NET CUSHION | | 10 | * |
| 71 | 00D 461 1307 004 | LID CUSHION | | 2 | * |
| 72 | 00D 461 1305 006 | ESC CUSHION | | 3 | * |
| 73 | nsp | SNOOZE PWB SPACER | | 3 | * |
| 74 | 00D 461 1306 005 | KNOB SPACER | | 13 | * |
| 75 | 432 510 0010 08D | LCD CUSHION | | 1 | * |
| 76 | 00D 461 1322 005 | EMI FILTER CUSHION | | 1 | * |
| 77 | 00D 461 1324 003 | POWER UNIT PWB SHEET | | 2 | * |
| 78 | 00D 415 1018 002 | INSULATING SHEET | | 3 | * |
| 79 | 00D 461 1314 000 | WIRE CUSHION | | 3 | * |
| 80 | 00D 461 1323 004 | MECHA FFC CUSHION | for S-52 | 1 | * |
| 81 | 432 510 0020 01D | PWB CUSHION | | 4 | * |
| 82 | nsp | SP BOX CUSHION | | 1 | * |
| 83 | nsp | PEF SHEET (L) | | 1 | * |
| 84 | nsp | PEF SHEET (R) | | 1 | * |
| 85 | nsp | SP BOX SPACER | | 2 | * |
| 86 | nsp | SP CABLE CUSHION | | 1 | * |
| 87 | nsp | SP CABLE CUSHION R | | 1 | * |
| 88 | nsp | NOISE INSULATE SHEET | | 1 | * |
| 89 | nsp | NOISE INSULATE (BTM) | for S-52 | 1 | * |
| SCREWS | | | | | |
| 101 | nsp | 2.6X5 CBTS (S)-Z | | 2 | |
| 102 | nsp | 2.6X8 CBTS (P)-Z | | 34 | |
| 103 | nsp | 3X4 CBTS (S)-Z | | 1 | |
| 104 | nsp | 3X6 CBTS(S)-Z | | 20 | |
| 105 | nsp | 3X6 CBTS(S)-B | | 32 | |
| 106 | nsp | 3X6 CBTS (S)-B | | 13 | |
| 107 | nsp | 3X8 CBTS (P)-B | | 26 | |
| 108 | nsp | 3X8 CBTS(B)-B | | 7 | |
| 109 | nsp | 3X10 CBTS (P)-Z | | 5 | |
| 110 | nsp | 3X10 CBTS(B)-Z | | 2 | |
| 111 | nsp | 3X16 CBTS (P)-B | | 6 | |
| 112 | nsp | 4X8 CBTS (P)-B | | 8 | |
| 113 | 00D 477 0064 107 | FIXING SCREW | | 4 | |
| 114 | - | WASHER | for ANNTENA CABLE | 1 | |
| 115 | - | NUT | for ANNTENA CABLE | 1 | |
| 116 | nsp | 3X6 CBTS(S)-Z | for S-52DABEK | 2 | |
| 117 | nsp | 3X6 CBTS(S)-B | for S-52DABEK | 2 | |

| Ref. No. | Part No. | Part Name | Remarks | Q'ty | New |
|--------------|------------------|-----------------------|-------------------------------|------|-----|
| 118 | nsp | 3W | | 2 | |
| 119 | 00D 477 0064 107 | FIXING SCREW | for S-52E2/DABEK/JP,S-32E3/E2 | 1 | |
| 120 | nsp | 3X6 CBTS(S)-B | for S-52E3 | 1 | |
| WIRES | | | | | |
| 153 | nsp | 4P VH CON.CORD | | 1 | * |
| 154 | nsp | 5P PH-PH CON.CORD | for S-52 | 1 | * |
| 155 | nsp | 5P PH-PH CON.CORD | | 1 | * |
| 156 | nsp | 6P PH-PH CON.CORD | | 1 | * |
| 157 | nsp | 6P ZH-ZH CON.CORD | | 1 | * |
| 158 | nsp | 6P PH-PH SHIELD CORD | | 1 | * |
| 159 | nsp | 9P PH-PH SHIELD CORD | | 1 | * |
| 160 | nsp | 11P PH-PH CON.CORD | | 1 | * |
| 161 | 00D 009 0236 033 | 15P FFC CABLE(1.25) | for S-52E2/DABEK/JP,S-32E3/E2 | 1 | * |
| 162 | nsp | 16P PHD-PHD CON.CORD | for S-52E3 | 1 | * |
| 163 | 00D 009 0285 039 | 30P FFC (1.0) | for S-52 | 1 | * |
| 164 | nsp | 1P COAX CABLE ASSY | for S-52DABEK | 1 | * |
| 165 | nsp | 1P WIRE (AWG18) | for S-52DABEK | 1 | * |
| 166 | nsp | 8P PH-PH SHIELD CORD | for S-52DABEK | 1 | * |
| 167 | nsp | 1P CONTACT ASSY | for S-52 | 1 | * |
| 168 | nsp | 4P PH-PH CON.CORD | | 1 | * |
| 169 | nsp | 13P PH-PH SHIELD CORD | | 1 | * |
| 170 | nsp | 3P ZH-SAN CON.CORD | | 1 | * |
| 171 | nsp | 1P SAN-EH CON.CORD | | 1 | * |
| 172 | nsp | 10P ZH-JB CON.CORD | | 1 | * |

EXPLODED VIEW OF CD MECHANISM UNIT

40 S-52, S-52DAB model only

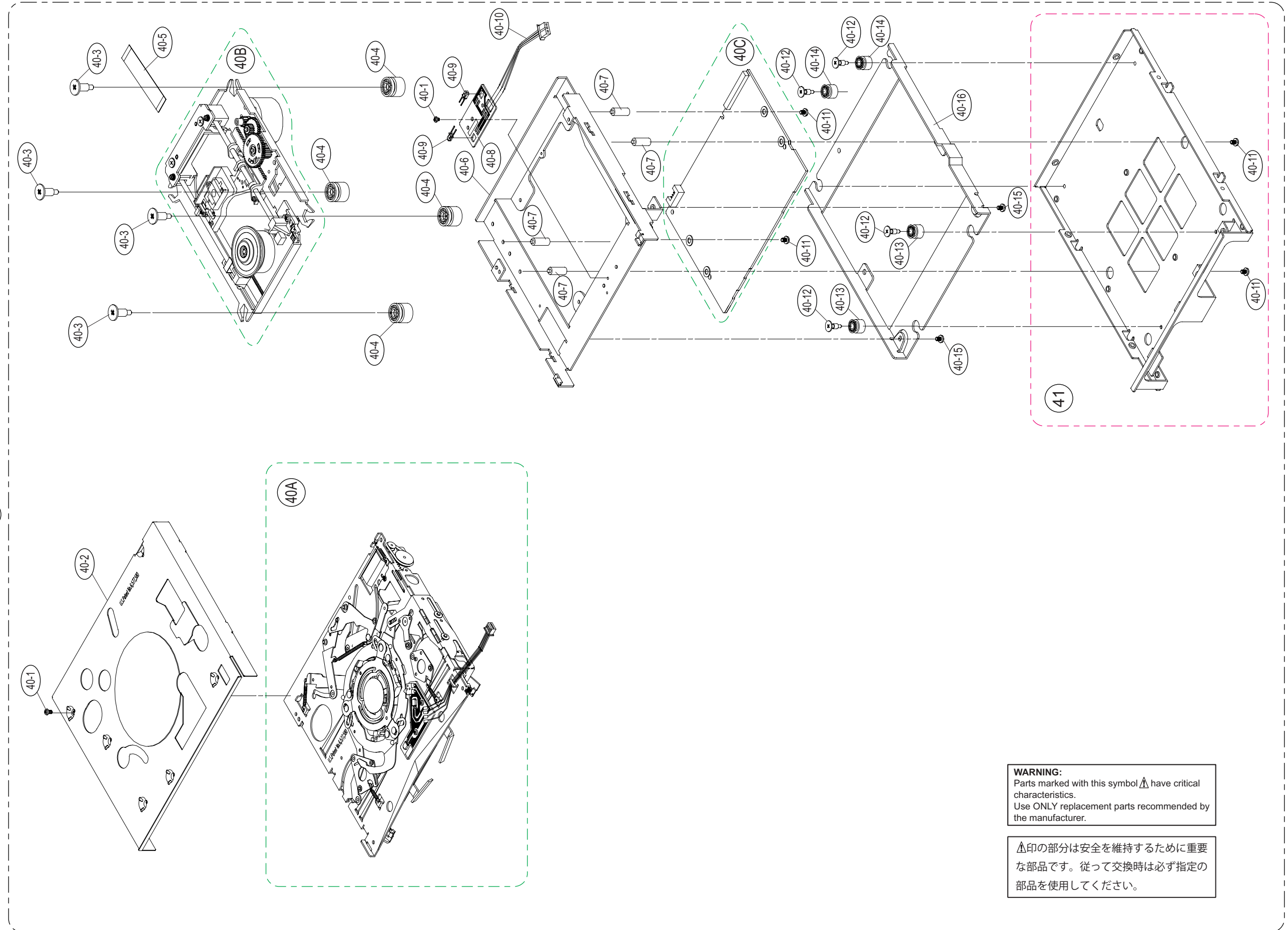

WARNING:
 Parts marked with this symbol  have critical characteristics.
 Use ONLY replacement parts recommended by the manufacturer.

印の部分は安全を維持するために重要な部品です。従って交換時は必ず指定の部品を使用してください。

PARTS LIST OF CD MECHANISM UNIT(S-52)

* 本表に "nsp" と記載されている部品は供給できません。

* Parts for which "nsp" is indicated on this table cannot be supplied.

* 本表に記載されている部品は、補修用部品のため製品に使用している部品とは一部、形状、寸法などが異なる場合があります。

* The parts listed below are for maintenance only, might differ from the parts used in the unit in appearances or dimensions.

| Ref. No. | Part No. | Part Name | Remarks | Q'ty | New | |
|----------|--------------|-------------------------------|---------|------------|-----|---|
| 40A | 00D9KA2A769 | FGDVS202MS-LOADER-UNIT | | A2A769 | 1 | * |
| 40B | 00D9KA2A770 | FGDVS202MS TRAVERSE-ASSY | | A2A770 | 1 | * |
| 40C | 00D9KA2A771 | FGDVS202MS PWB-AS | | A2A771 | 1 | * |
| 40-1 | nsp | M2 × 4 BIND S-TIGHT CR3 | | BCS04U3 | 3 | |
| 40-2 | nsp | TOP-COVER | | C8P118 | 1 | |
| 40-3 | nsp | SCW-DAMPER-CR3 | | C1H012 | 4 | |
| 40-4 | 00D9KA2G734 | DAMPER SI50 | | A2G734 | 4 | * |
| 40-5 | 00D9KC2P183 | FFC 0.5-24 ^φ L70-G | | C2P183 | 1 | |
| 40-6 | nsp | MAIN-BASE | | A2P834 | 1 | |
| 40-7 | nsp | PCB-SHAFT | | A2H073 | 4 | |
| 40-8 | nsp | SENSOR-PCB-HF | | C8P046 | 1 | |
| 40-9 | 00D9KECEL012 | PT4800BCE00F | | ECEL012 | 2 | |
| 40-10 | nsp | CNW-3P-PN | | C8G046 | 1 | |
| 40-11 | nsp | M2.6X6 BIND-TYPE-BK-CR3 | | BDZ06K3 | 4 | |
| 40-12 | nsp | SCW-DAMPER-CR3 | | C1H013 | 4 | |
| 40-13 | 00D9KC2G083 | DAMPER-IDLE | | C2G083 | 2 | |
| 40-14 | 00D9KA2G643 | DAMPER-SI25-LB | | A2G643 | 2 | |
| 40-15 | nsp | M2.6X6 BIND-S-TIGHT-CR3 | | BDS06U3 | 4 | |
| 40-16 | nsp | MECHA-BRACKET | | 4125413109 | 1 | |
| 41 | nsp | MAIN CHASSIS | | 4112119102 | 1 | * |

PARTS LIST OF PACKING & ACCESSORIES

* 本表に "nsp" と記載されている部品は供給できません。

* Parts for which "nsp" is indicated on this table cannot be supplied.

* 本表に記載されている部品は、補修用部品のため製品に使用している部品とは一部、形状、寸法などが異なる場合があります。

* The parts listed below are for maintenance only, might differ from the parts used in the unit in appearances or dimensions.

Note: The symbols in the column "Remarks" indicate the following destinations.

E3 : U.S.A. & Canada model

E2 : Europe model

EK : U.K. model

JP : Japan model

SR : Silver model

WT : White model

| Ref. No. | Part No. | Part Name | Remarks | Q'ty | New |
|----------|------------------|----------------------|-------------------------------|------|-----|
| 1 | 00D 501 2378 107 | CARTON CASE | for S-52SRE3/WTE3 | 1 | * |
| 1 | 531 210 0170 02D | CARTON CASE | for S-52SRE2/WTE2 | 1 | * |
| 1 | 00D 501 2378 136 | CARTON CASE | for S-52SRJP | 1 | * |
| 1 | 00D 501 2378 149 | CARTON CASE | for S-32E2 | 1 | * |
| 1 | 00D 501 2378 152 | CARTON CASE | for S-32E3 | 1 | * |
| 1 | 00D 501 2378 165 | CARTON CASE | for S-52DABEK | 1 | * |
| 1 | 00D 501 2378 178 | CARTON CASE | for S-52WTJP | 1 | * |
| 2 | 00D 505 0312 073 | CABINET COVER | | 1 | * |
| 3 | 00D 503 1557 103 | CUSHION (L) | | 1 | * |
| 4 | 00D 503 1558 102 | CUSHION (R) | | 1 | * |
| 5 | 00D 502 1144 005 | PAD | | 1 | * |
| 6 | 00D 502 1148 001 | REAR CUSHION | for S-52DABEK | 1 | * |
| 7 | nsp | ENVELOPE | for INST.MANUAL | 1 | |
| 8 | 00D 511 4687 000 | INST. MANUAL (E3) | for S-52E3 | 1 | * |
| 8 | 00D 511 4688 009 | INST. MANUAL (E2) | for S-52E2/DABEK | 1 | * |
| 8 | 00D 511 4690 000 | INST. MANUAL (J) | for S-52JP | 1 | * |
| 8 | 00D 511 4691 009 | INST. MANUAL (E3) | for S-32E3 | 1 | * |
| 8 | 00D 511 4692 008 | INST. MANUAL (E2) | for S-32E2 | 1 | * |
| 9 | nsp | S.S.LIST(EX) | for S-52E3/E2/DABEK,S-32E3/E2 | 1 | |
| 10 | nsp | T. MEDIA GUIDE SHEET | for S-52E3/E2/DABEK,S-32E3/E2 | 1 | * |
| 11 | nsp | RHAPSODY GUIDE SHEET | for S-52E3,S-32E3 | 1 | * |
| 12 | nsp | XM SHEET | for S-52E3 | 1 | |
| 13 | nsp | WARRANTY (HOME) | for S-52E3,S-32E3 | 1 | |
| 14 | 00D 515 0918 607 | SERVICE STATION LIST | for S-52JP | 1 | |
| 15 | nsp | POLY COVER | for ACCESSARY | 1 | |
| 16 | 00D 399 1121 008 | REMOCON(RC1083) | for S-52SR | 1 | * |
| 16 | 00D 399 1121 011 | REMOCON(RC1083)(W) | for S-52WT | 1 | * |
| 17 | 00D 399 1123 006 | REMOCON(RC1089) | for S-32 | 1 | * |
| 18 | nsp | BATTERY (UM-4) ASS | | 1 | |
| 19 | 00D 231 1152 001 | AM LOOP ANTENNA(S) | for S-52E2/DABEK/JP,S-32E2/E3 | 1 | |
| 20 | 00D 395 0026 005 | FM ANT. WIRE | for S-52E2/DABEK,S-32E2 | 1 | |
| 21 | 00D 395 0034 000 | WLAN ANNTENA | | 1 | |
| △ | 22 | 00D 206 2253 000 | AC CORD E2 INLET (V) | 1 | * |
| △ | 22 | 00D 206 2254 009 | AC CORD E3 INLET (V) | 1 | * |
| △ | 22 | 00D 206 2256 007 | AC CORD J INLET (V) | 1 | * |
| △ | 23 | 00D 206 2255 008 | AC CORD EK INLET (V) | 1 | * |
| | 24 | 00D 146 2519 002 | DOCK ADAPTER ASSY | 1 | * |
| | 24 | 00D 146 2519 015 | DOCK ADAPTER ASSY | 1 | * |
| | 25 | 00D 231 1153 000 | AM LOOP ANTENNA(HD) | 1 | * |
| | 26 | 00D 395 0028 003 | FM ANT ASS Y(F/WELT) | 1 | * |
| | 27 | 00D 395 0030 004 | DAB ROOM ANT | 1 | * |
| | 28 | nsp | E2 POS LABEL | 1 | * |
| | 28 | nsp | E2 POS LABEL | 1 | * |
| | 28 | nsp | E2 POS LABEL | 1 | * |
| | 28 | nsp | UPC LABEL | 1 | * |
| | 28 | nsp | UPC LABEL | 1 | * |
| | 28 | nsp | UPC LABEL | 1 | * |
| | 28 | 00D 517 1530 006 | POS LABEL | 1 | * |
| | 28 | 00D 517 1530 019 | POS LABEL | 1 | * |

| Ref. No. | Part No. | Part Name | Remarks | Q'ty | New |
|----------|------------------|----------------------|-------------------------------|------|-----|
| 29 | nsp | EK POS LABEL | for S-52DABEK | 2 | * |
| 30 | - | CONT.CARD(L)SUB ASSY | for S-52E3/E2/DABEK,S-32E3/E2 | 1 | |
| 31 | 00D 515 0920 307 | GUARANTEE CARD (M) | for S-52JP | 1 | |
| 32 | nsp | WIFI LABEL (CARTON) | for S-52E2/DABEK,S-32E2 | 1 | |
| 33 | 544 110 0680 07D | COLOR LABEL | for S-52SRJP/SRE2/SRE3 | 4 | * |
| 34 | 544 110 0680 14D | COLOR LABEL | for S-52WTJP/WTE2/WTE3 | 4 | * |

△
△

S32 WIRING DIAGRAM

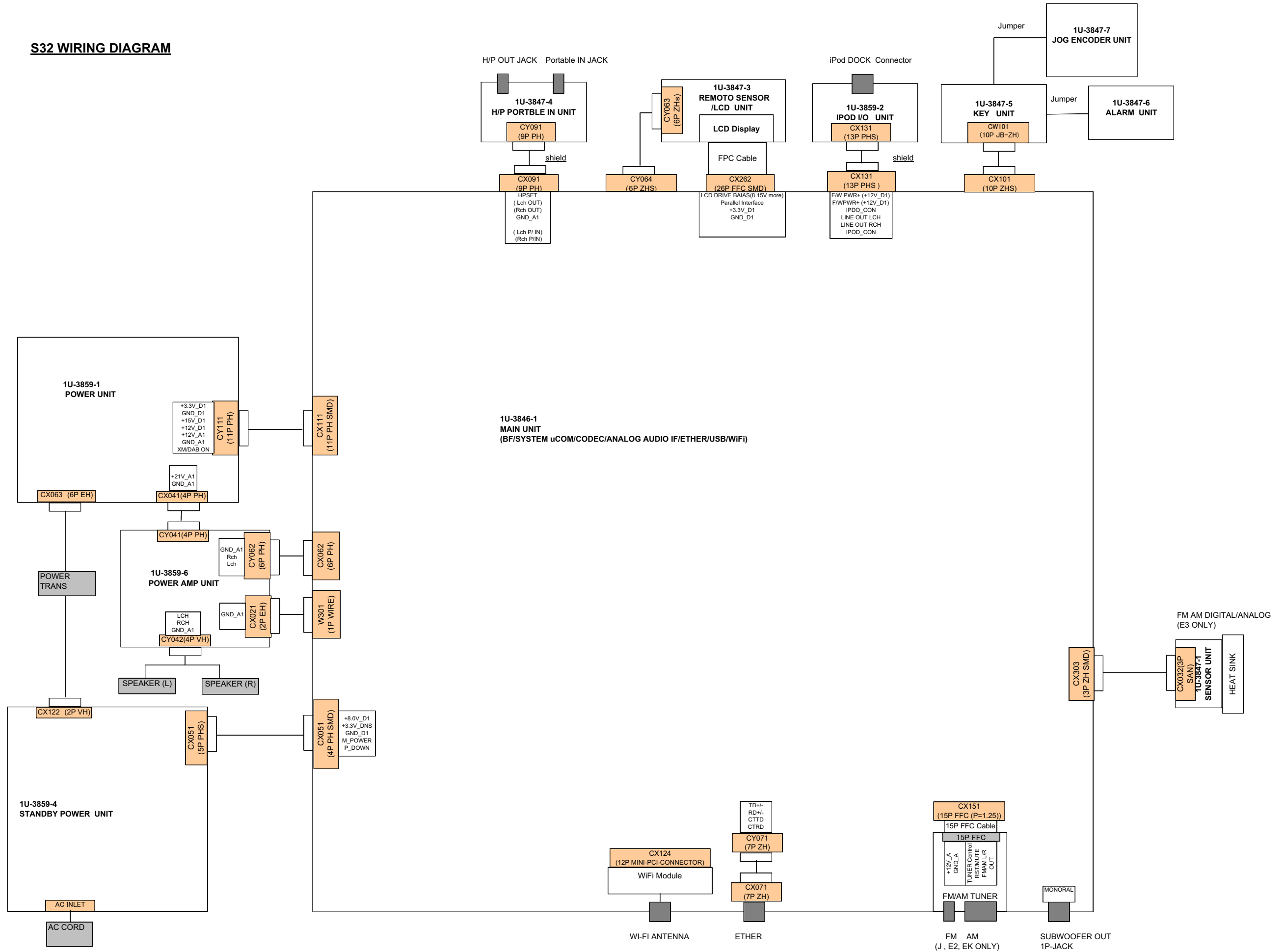

S52 WIRING DIAGRAM

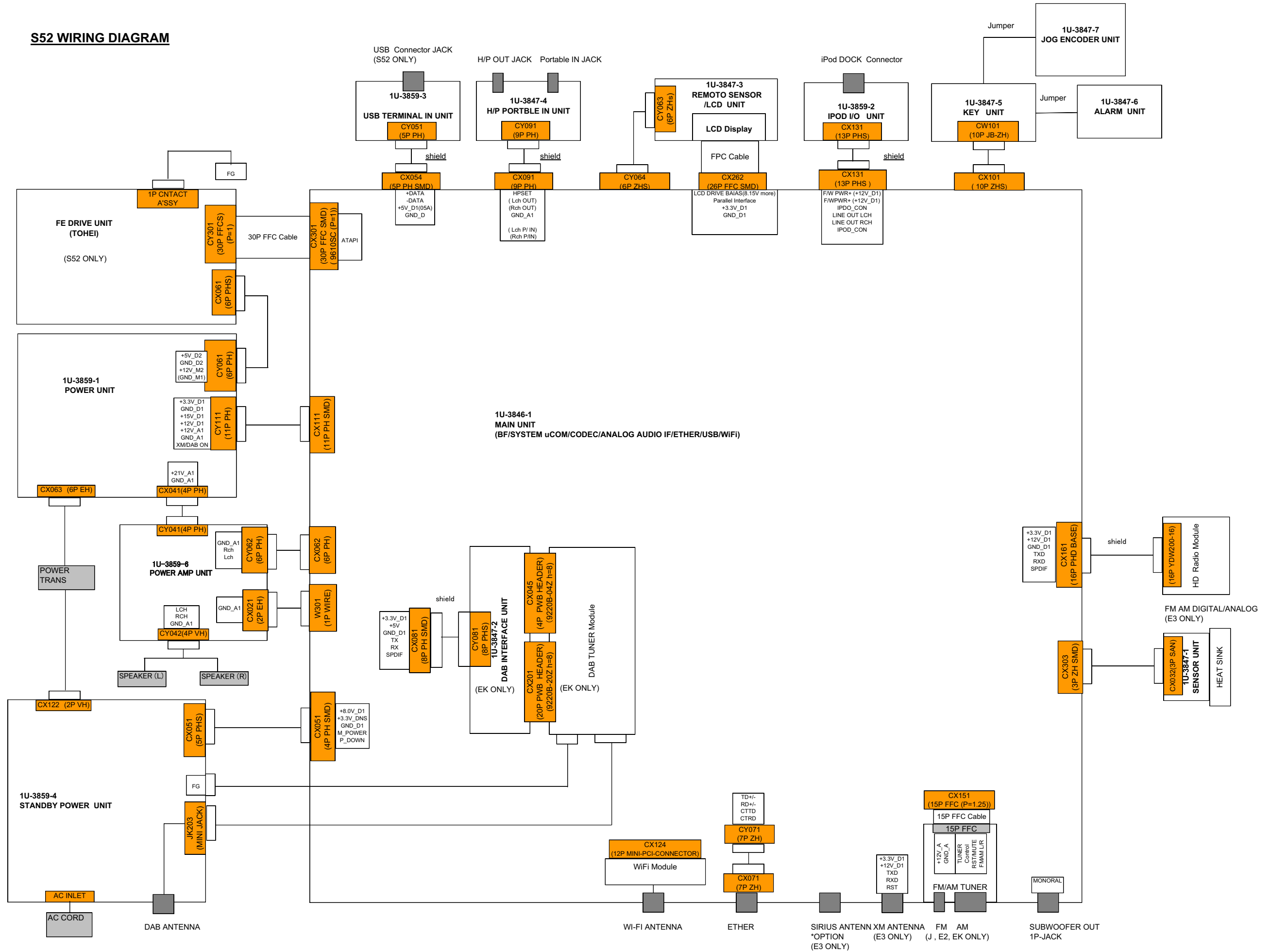

MEASURING METHOD AND WAVEFORMS

To check the waveforms on the FEP, the GND (-) probe of the oscilloscope to "VHALF" point.
(Except for Inner SW, TRVSW)

NOTES

Measuring Disc: CD/TCD-784

(It is better to use wires for extending between the probe and test points.)

- When watching the HF waveform, use the extending wire as short as possible.
- When HF waveform is noisy or cannot discriminate the eye-pattern, replace the Traverse Unit after measuring the lop.
- ① ~ ⑬ points have the certain test points shown below.

各部の波形と測定方法

FEP 基板の波形チェックを行うためにはオシロスコープの GND(-) プローブを "VHALF" ポイントに接続します。

注意

測定ディスク： CD/TCD-784

(テストポイントとプローブ間に延長ワイヤを使用するのがより良い方法です。)

- HF 波形を観測する場合、できるだけ短い延長ワイヤを使用してください。
- HF 波形がノイズで不明瞭、またはアイパターンが識別不能の場合は lop 測定後にトラバースユニットを交換してください。
- ポイント①～⑬は、下図のように特定テストポイント付きです。

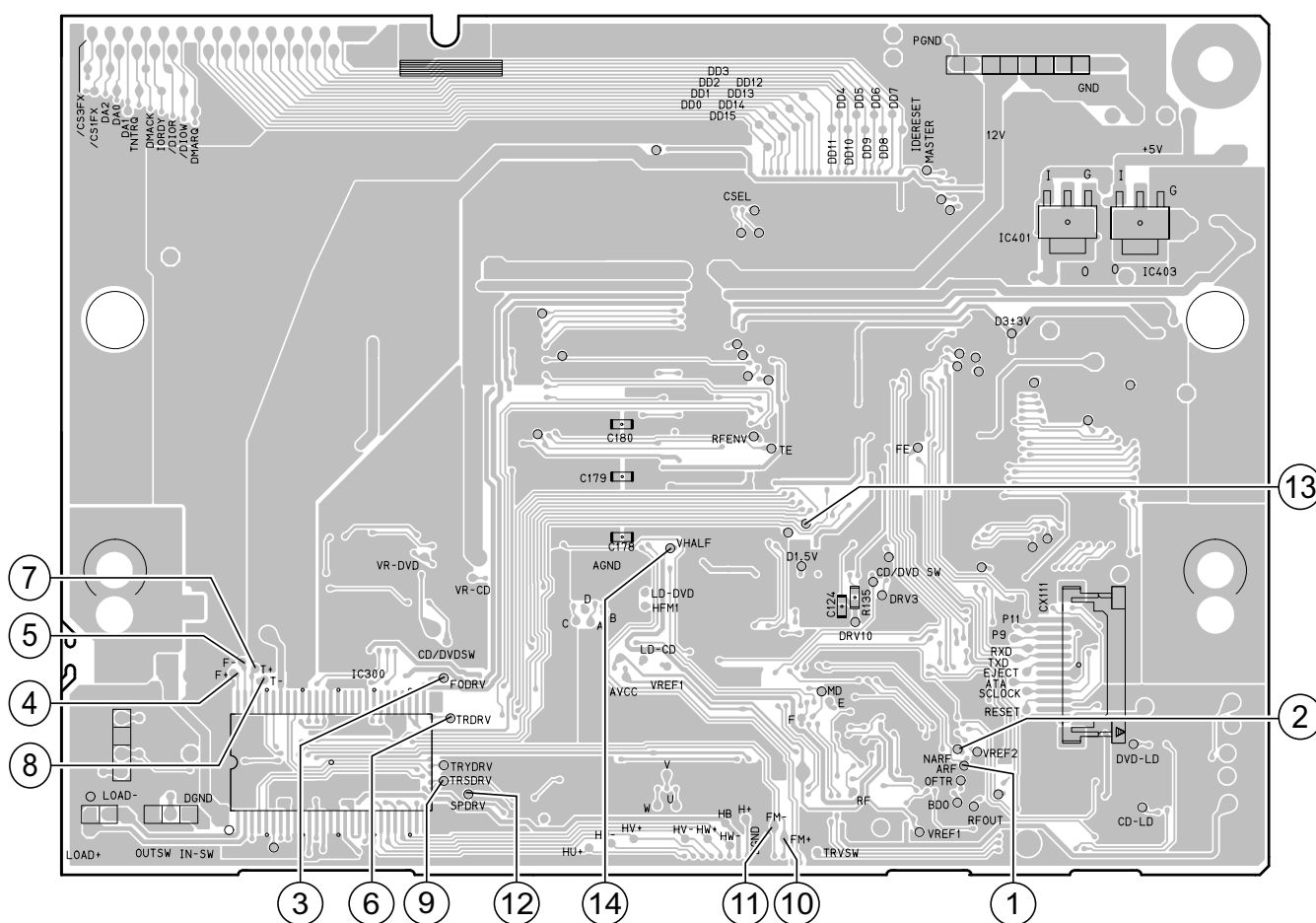

IU-3851 FEP Unit : Foil Side

* For ARF ①, use NARF ② as the reference (probe ⊖) for the oscilloscope, VHALF ⑭ as the reference voltage for other points.

* ARF ①は NARF ②をオシロスコープの基準 (プローブ ⊖) とし、他のポイントの基準電圧は VHALF ⑭です。

WAVEFORMS

IU-3851 FEP Unit

CD PLAY Disc : TCD-784

RF waveform

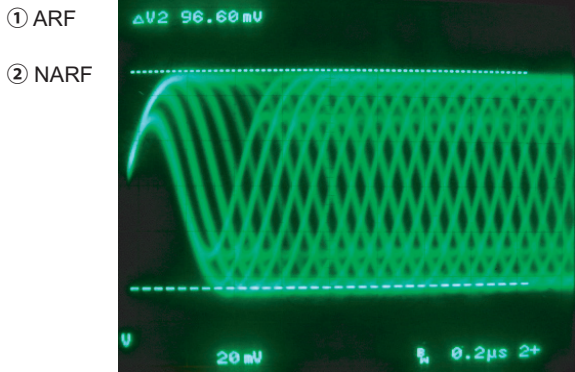

RANGE .2 v .2 μ sec

SEARCH (INNER → OUTER)

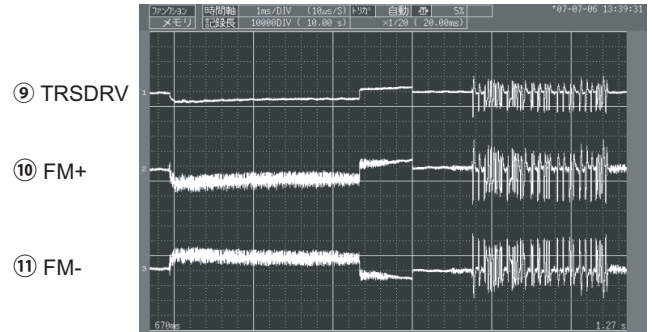

RANGE ⑨ 1 v
⑩ 1 v 20 msec
⑪ 1 v

CD LOADING → PLAY

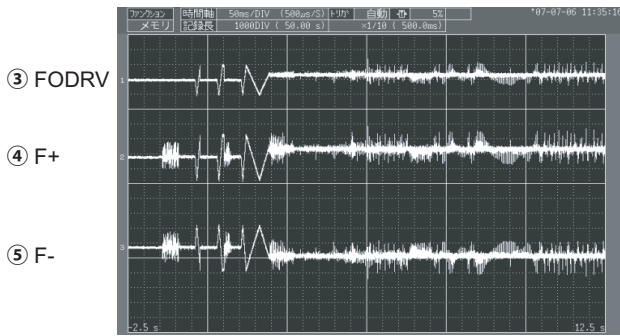

RANGE ③ .5 v
④ .5 v 0.5 sec
⑤ .5 v

CD PLAY (INNER)

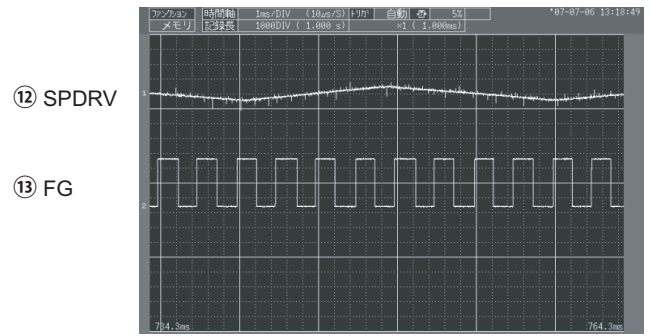

RANGE ⑫ .1 v 1 msec
⑬ 1 v

CD PLAY



RANGE ⑥ .2 v
⑦ .2 v 100 μ sec
⑧ .2 v

IU-3846 MAIN Unit

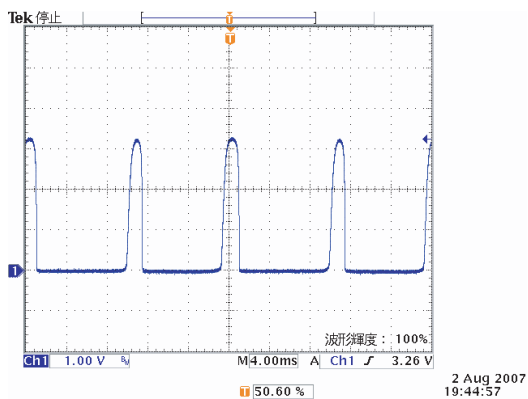

(A) Wave form1: PWR_OFF_DET 50/60 Waveform
 波形1: 停電検出50/60波形
 CX051 5pin
 (Refer to the SCHEMATIC DIAGRAMS 4/7)
 (SCHEMATIC DIAGRAMS 4/7を参照)

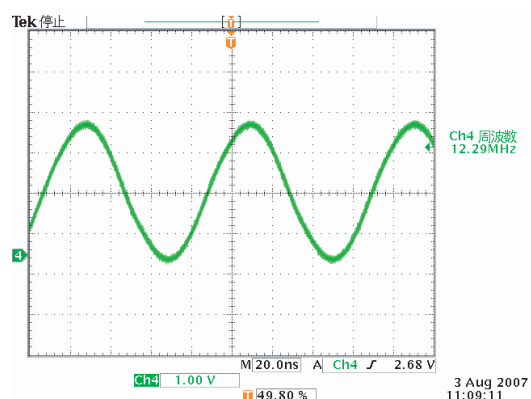

(C) Wave form 3 : CLOCK Waveform (12.288MHz)
 波形3: クロック波形 (12.288MHz)
 X301
 (Refer to the SCHEMATIC DIAGRAMS 3/7)
 (SCHEMATIC DIAGRAMS 3/7を参照)

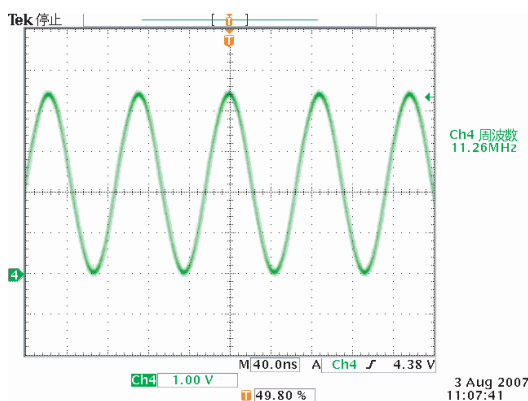

(B) Wave form 2 : CLOCK Waveform (11.2896MHz)
 波形2: クロック波形 (11.2896MHz)
 X302
 (Refer to the SCHEMATIC DIAGRAMS 3/7)
 (SCHEMATIC DIAGRAMS 3/7を参照)

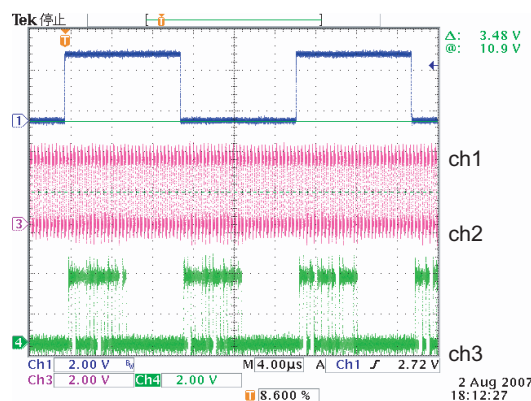

(D) Wave form 4 : A/D Waveform
 波形4: A/D波形
 CH1:IC300 10pin
 CH2:IC300 11pin
 CH3:IC300 32pin
 (Refer to the SCHEMATIC DIAGRAMS 3/7)
 (SCHEMATIC DIAGRAMS 3/7を参照)

IU-3859-6 POWER AMP Unit

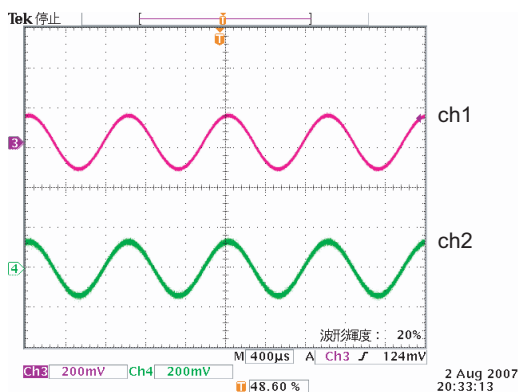

(E) Wave form 5 : Power Amp In Waveform
 波形5: パワーアンプ入力波形
 CH1:IC505 2pin
 CH2:IC505 4pin
 (Refer to the SCHEMATIC DIAGRAMS 6/7)
 (SCHEMATIC DIAGRAMS 6/7を参照)

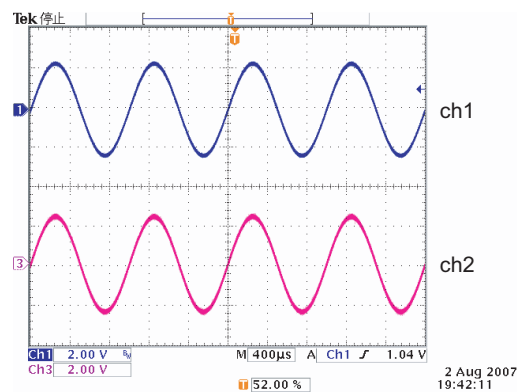

(F) Wave form 6 : Speaker In Waveform
 波形6: スピーカー入力波形
 CH1:CY042 1pin
 CH2:CY042 4pin
 (Refer to the SCHEMATIC DIAGRAMS 6/7)
 (SCHEMATIC DIAGRAMS 6/7を参照)

NOTE FOR SCHEMATIC DIAGRAM

WARNING:

Parts marked with this symbol \triangle have critical characteristics. Use ONLY replacement parts recommended by the manufacturer.

CAUTION:

Before returning the unit to the customer, make sure you make either (1) a leakage current check or (2) a line to chassis resistance check. If the leakage current exceeds 0.5 milliamps, or if the resistance from chassis to either side of the power cord is less than 460 kohms, the unit is defective.

WARNING:

DO NOT return the unit to the customer until the problem is located and corrected.

NOTICE:

ALL RESISTANCE VALUES IN OHM. k=1,000 OHM
M=1,000,000 OHM
ALL CAPACITANCE VALUES IN MICRO FARAD.
P=MICRO-MICRO FARAD
EACH VOLTAGE AND CURRENT ARE MEASURED AT
NO SIGNAL INPUT CONDITION.
CIRCUIT AND PARTS ARE SUBJECT TO CHANGE
WITHOUT PRIOR NOTICE.

配線図について

\triangle 印の部品は安全を維持するために重要な部品です。従って交換時は必ず指定の部品を使用してください。

注)

- (1) 指定なき抵抗値は Ω 、k は k Ω 、M は M Ω を示す。
- (2) 指定なきコンデンサーの値は μF 、p は pF を示す。
- (3) 各部の電圧は無信号の値を示す。
- (4) この配線図は基本配線図です。改良等のため変更することがありますのでご了承ください。

1U-3846-1
MAIN UNIT
[BF block]

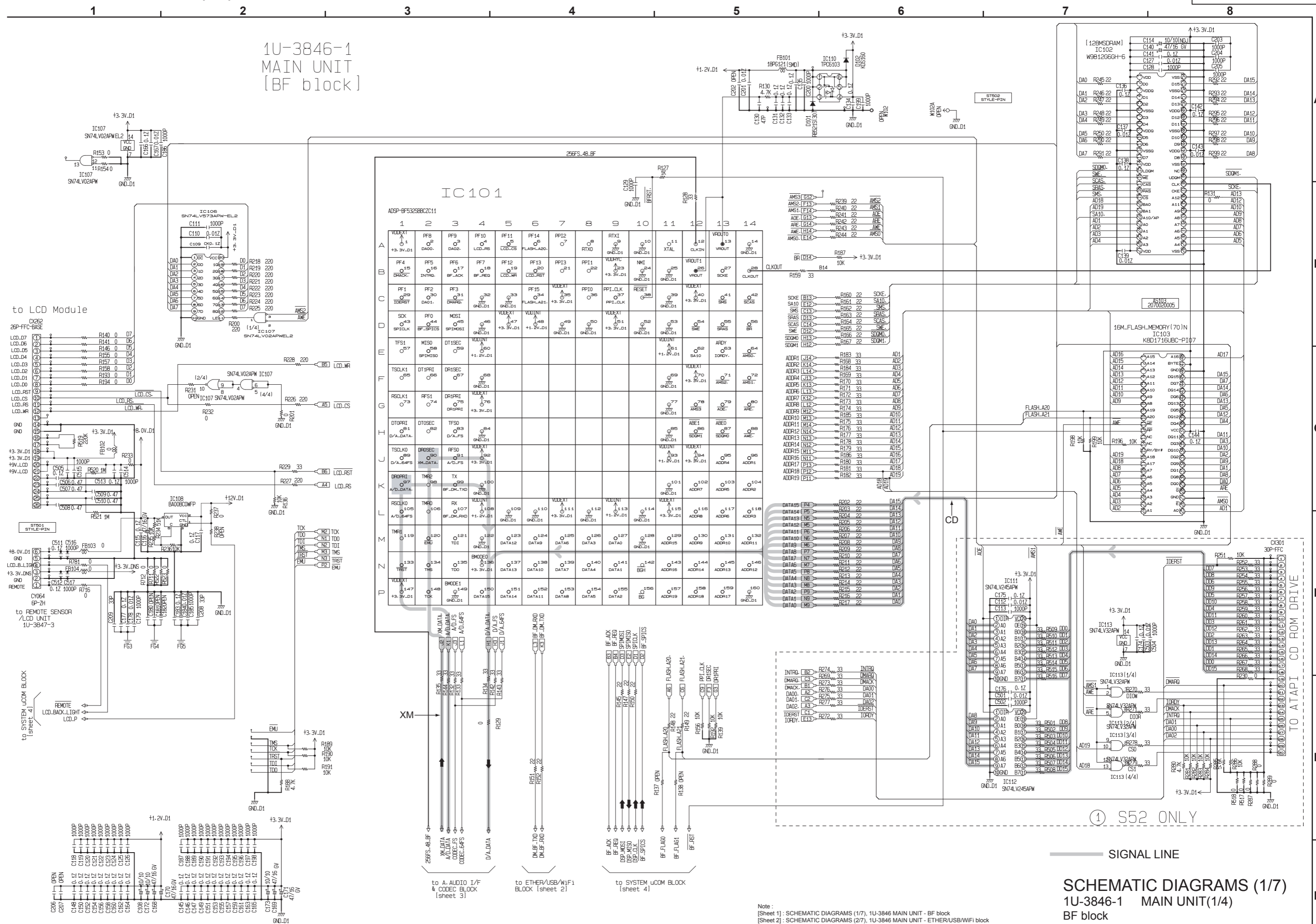

Note:
 [Sheet 1]: SCHEMATIC DIAGRAMS (1/7), 1U-3846 MAIN UNIT - BF block
 [Sheet 2]: SCHEMATIC DIAGRAMS (2/7), 1U-3846 MAIN UNIT - ETHER/USB/WiFi block
 [Sheet 3]: SCHEMATIC DIAGRAMS (3/7), 1U-3846 MAIN UNIT - ANALOG AUDIO I/F/CODEC block
 [Sheet 4]: SCHEMATIC DIAGRAMS (4/7), 1U-3846 MAIN UNIT - SYSTEM uCOM block

| | S52 E2/E3/EK S32 E3/E2 | S52 J |
|-------|---------------------------|-------|
| TR311 | KRC102S | OPEN |
| TR312 | DTA114T | OPEN |
| TR313 | KRC107S | OPEN |
| TR314 | 2SB1182-R(F5) | OPEN |
| C367 | 0.1Z | OPEN |
| R408 | 2.2K | OPEN |
| R413 | 10K | OPEN |

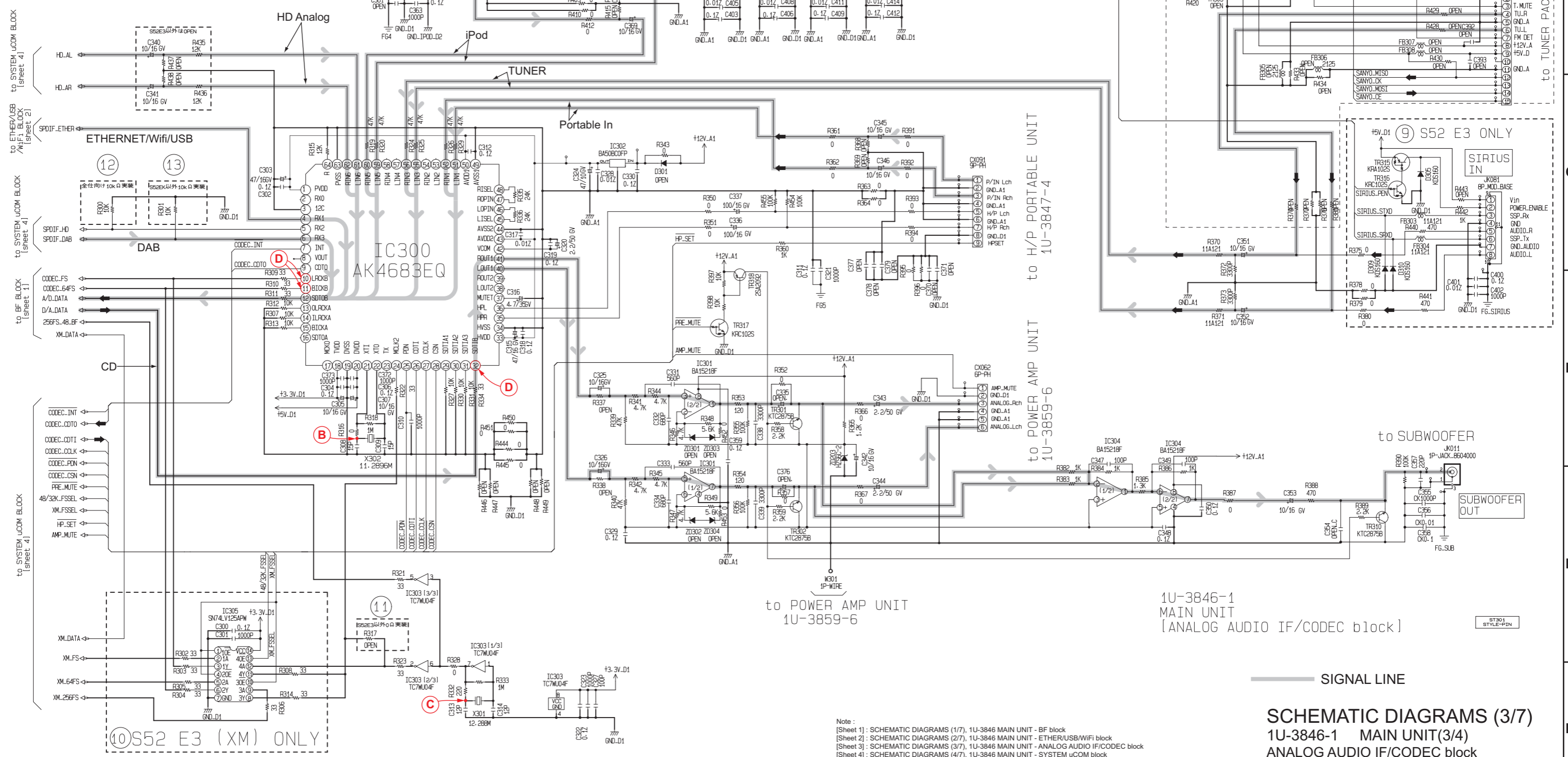

⑩ S52 E3 (XM) ONLY

Note :
 [Sheet 1] : SCHEMATIC DIAGRAMS (1/7), 1U-3846 MAIN UNIT - BF block
 [Sheet 2] : SCHEMATIC DIAGRAMS (2/7), 1U-3846 MAIN UNIT - ETHER/USB/WiFi block
 [Sheet 3] : SCHEMATIC DIAGRAMS (3/7), 1U-3846 MAIN UNIT - ANALOG AUDIO IF/CODEC block
 [Sheet 4] : SCHEMATIC DIAGRAMS (4/7), 1U-3846 MAIN UNIT - SYSTEM uCOM block

1U-3846-1
 MAIN UNIT
 [ANALOG AUDIO IF/CODEC block]

— SIGNAL LINE

SCHEMATIC DIAGRAMS (3/7)
 1U-3846-1 MAIN UNIT(3/4)
 ANALOG AUDIO IF/CODEC block

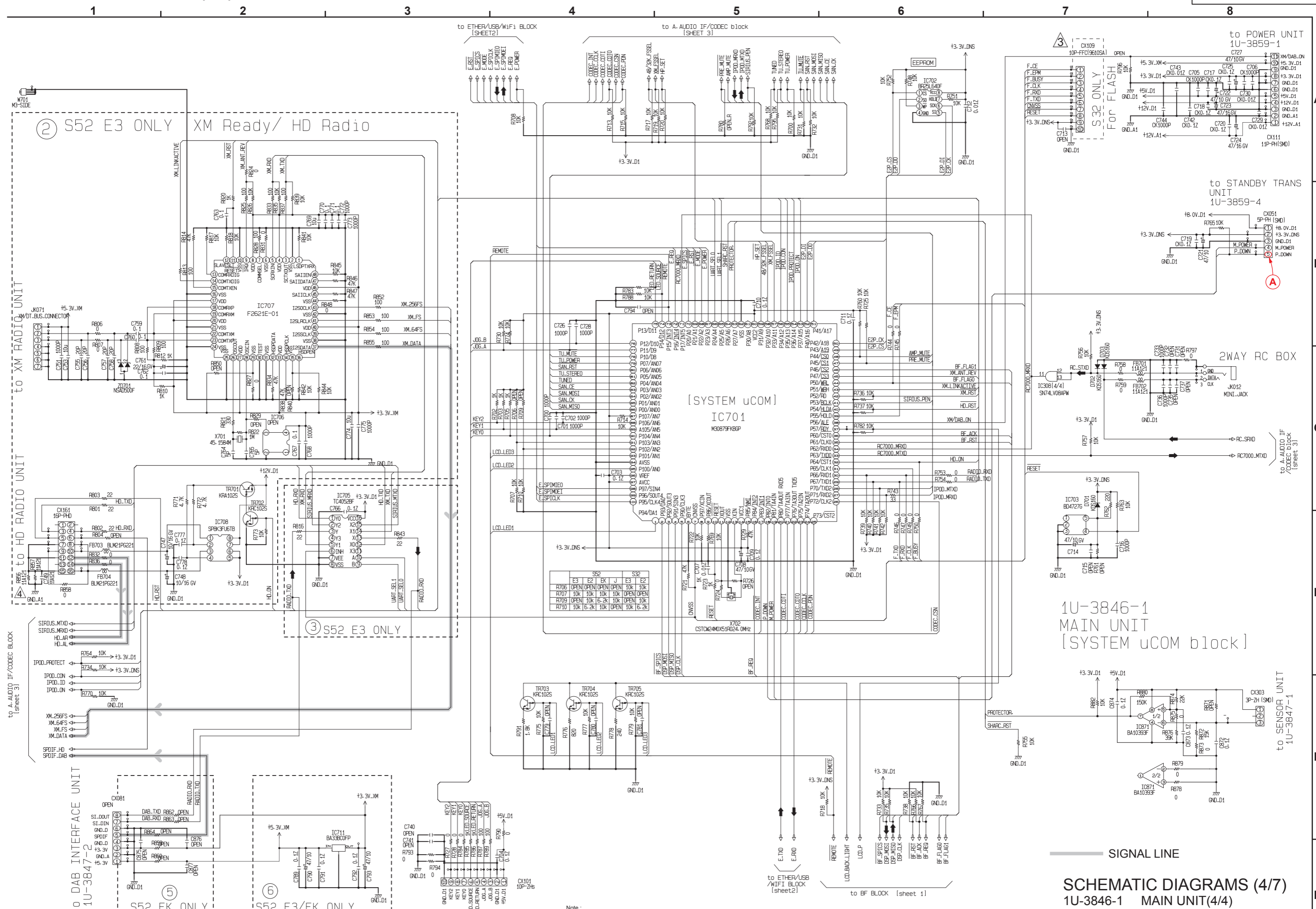

② S52 E3 ONLY XM Ready/ HD Radio

③ S52 E3 ONLY

⑤ S52 EK ONLY

⑥ S52 E3/EK ONLY

| S52 | | S32 | |
|------|------|------|------|
| E3 | E2 | E3 | E2 |
| R705 | OPEN | OPEN | OPEN |
| R707 | 10K | 10K | 10K |
| R709 | OPEN | 10K | 10K |
| R710 | 10K | 6.2K | 10K |

Note :
 [Sheet 1] : SCHEMATIC DIAGRAMS (1/7), 1U-3846 MAIN UNIT - BF block
 [Sheet 2] : SCHEMATIC DIAGRAMS (2/7), 1U-3846 MAIN UNIT - ETHER/USB/WIFI block
 [Sheet 3] : SCHEMATIC DIAGRAMS (3/7), 1U-3846 MAIN UNIT - ANALOG AUDIO IF/CODEC block
 [Sheet 4] : SCHEMATIC DIAGRAMS (4/7), 1U-3846 MAIN UNIT - SYSTEM uCOM block

1U-3846-1
 MAIN UNIT
 [SYSTEM uCOM block]

SIGNAL LINE

SCHEMATIC DIAGRAMS (4/7)
 1U-3846-1 MAIN UNIT(4/4)
 SYSTEM uCOM block

to MAIN UNIT 1U-3846-1
BF block (sheet 1)

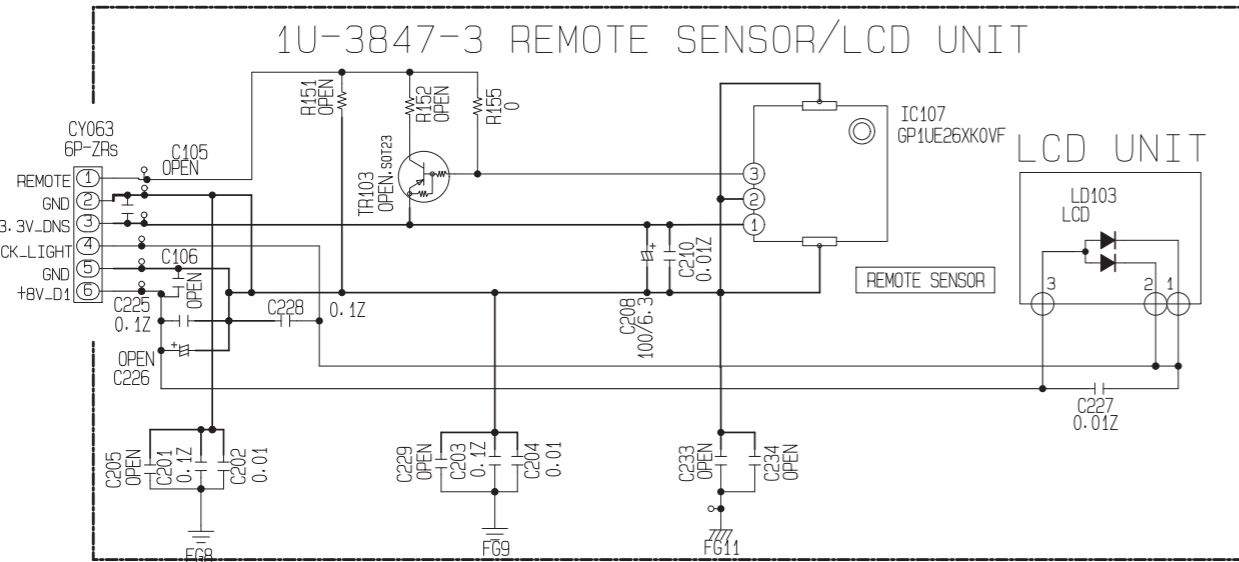

to MAIN UNIT 1U-3846-1
ANALOG AUDIO IF/CODEC block
(sheet 3)

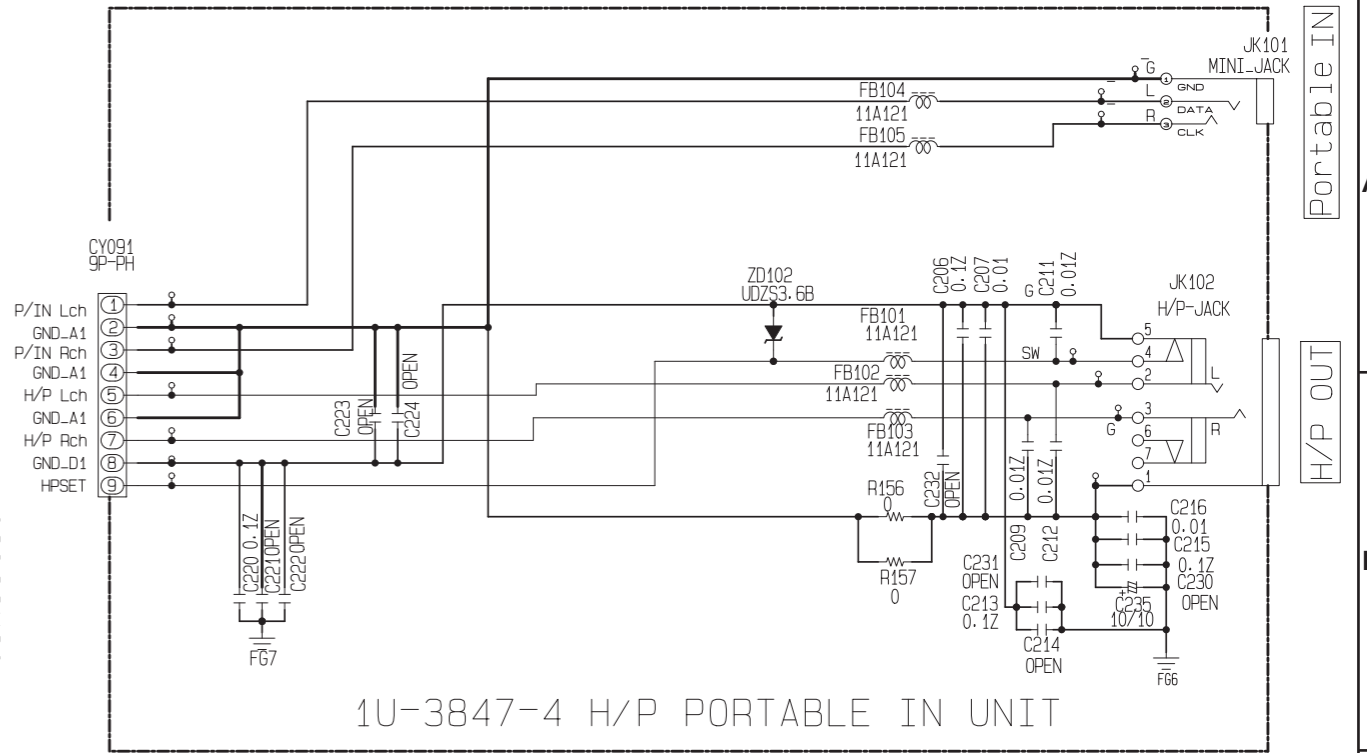

To DAB UNIT

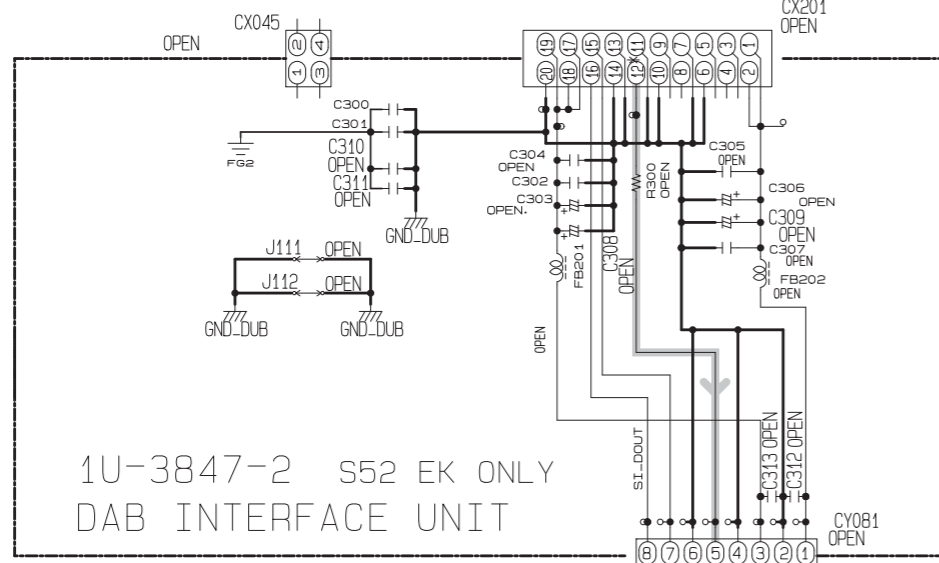

1U-3847-2 S52 EK ONLY
DAB INTERFACE UNIT

to MAIN UNIT 1U-3846-1
SYSTEM uCOM block (sheet 4)

to MAIN UNIT 1U-3846-1
SYSTEM uCOM block (sheet 4)

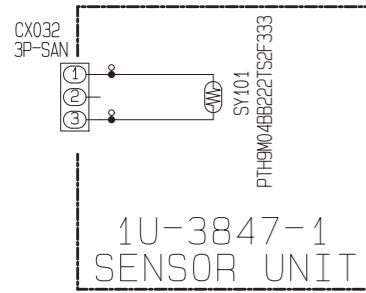

1U-3847-1
SENSOR UNIT

to MAIN UNIT 1U-3846-1
SYSTEM uCOM block (sheet 4)

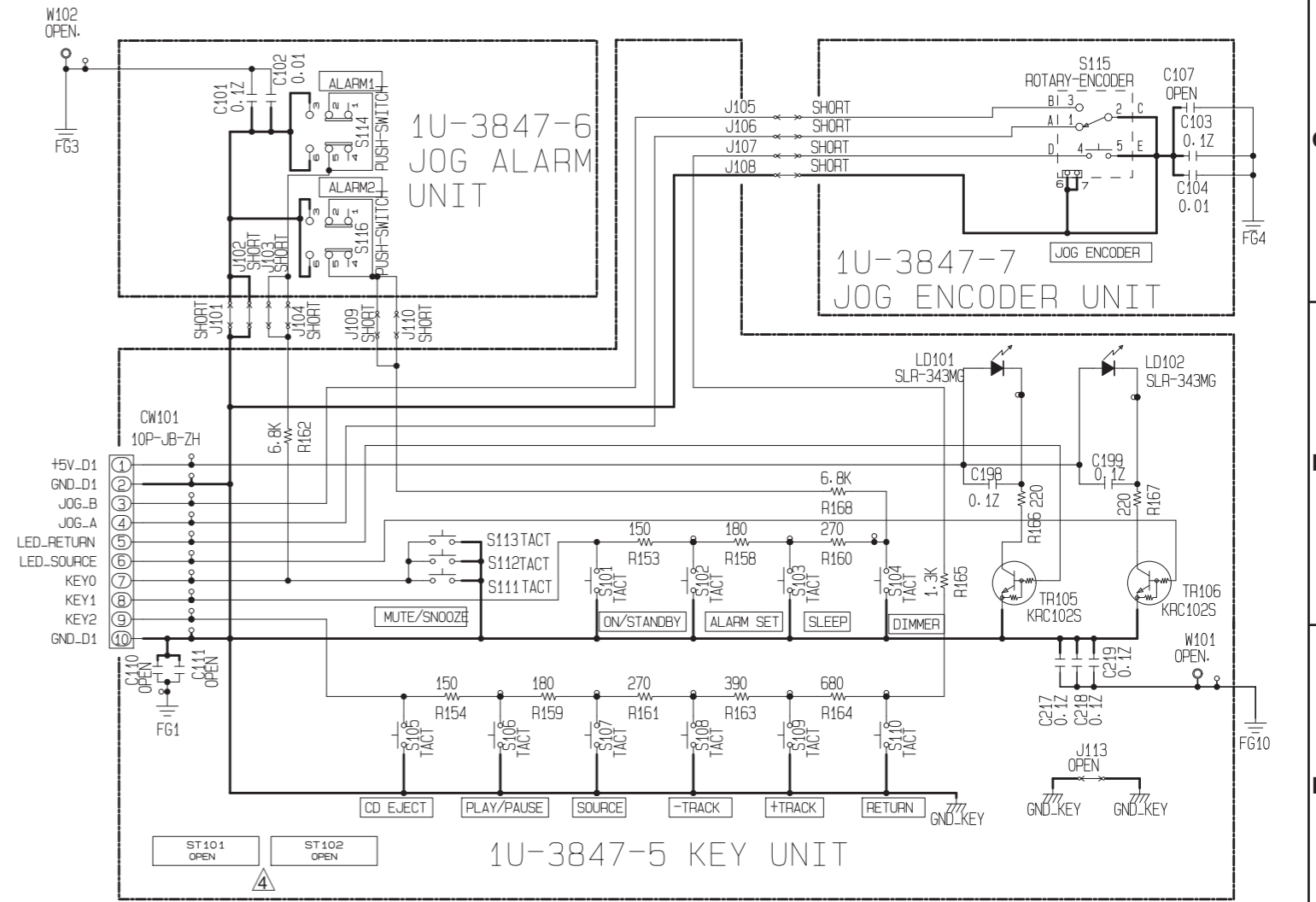

1U-3847-5 KEY UNIT

— SIGNAL LINE

- SCHEMATIC DIAGRAMS (5/7)**
- 1U-3847 POWER AMP/KEY UNIT(1/1)
 - 1U-3847-1 SENSOR UNIT
 - 1U-3847-2 DAB INTERFACE UNIT (EK model only)
 - 1U-3847-3 REMOTE SENSOR/LCD UNIT
 - 1U-3847-4 H/P PORTABLE IN UNIT
 - 1U-3847-5 KEY UNIT
 - 1U-3847-6 JOG ALARM UNIT
 - 1U-3847-7 JOG ENCODER UNIT

Note :
 (Sheet 1) : SCHEMATIC DIAGRAMS (1/7), 1U-3846 MAIN UNIT - BF block
 (Sheet 2) : SCHEMATIC DIAGRAMS (2/7), 1U-3846 MAIN UNIT - ETHER/USB/WIFI block
 (Sheet 3) : SCHEMATIC DIAGRAMS (3/7), 1U-3846 MAIN UNIT - ANALOG AUDIO IF/CODEC block
 (Sheet 4) : SCHEMATIC DIAGRAMS (4/7), 1U-3846 MAIN UNIT - SYSTEM uCOM block

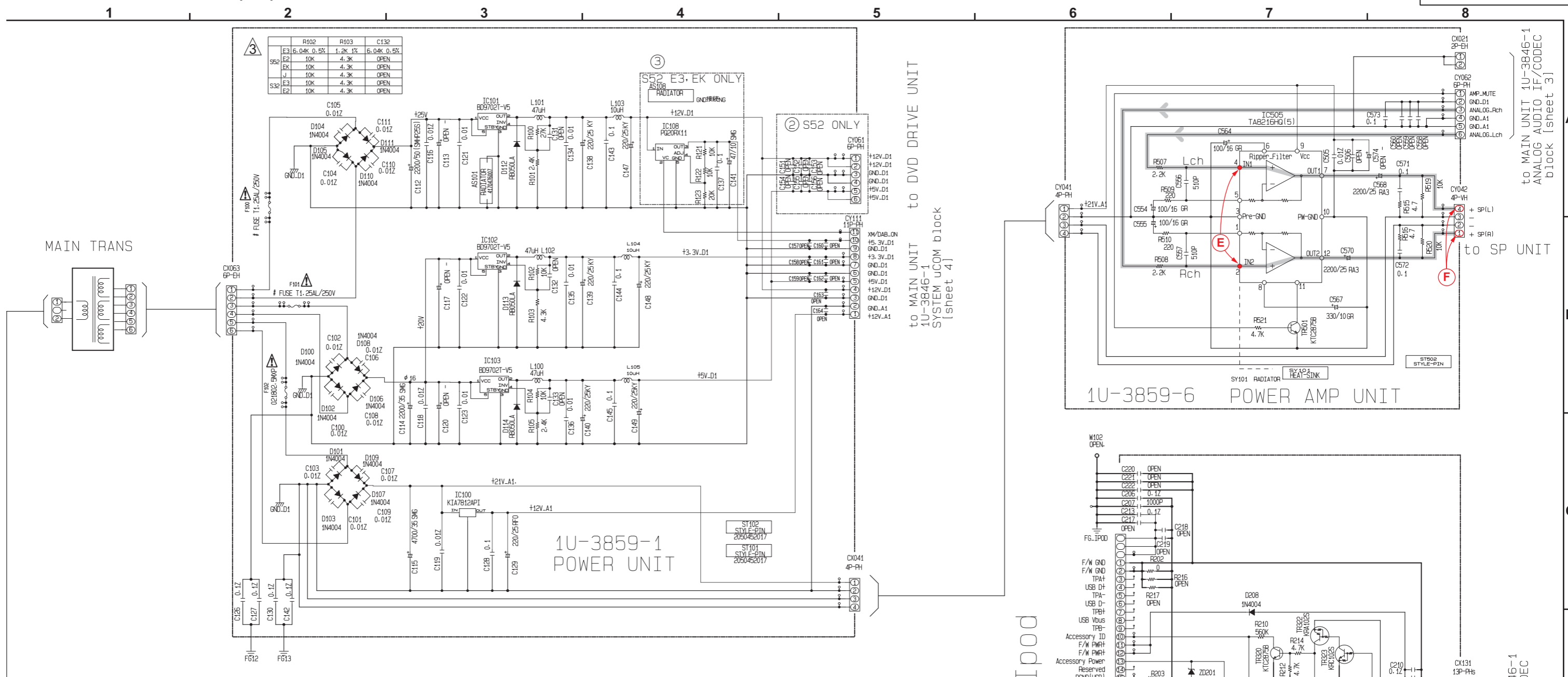

Note :
 (Sheet 1) : SCHEMATIC DIAGRAMS (1/7), 1U-3846 MAIN UNIT - BF block
 (Sheet 2) : SCHEMATIC DIAGRAMS (2/7), 1U-3846 MAIN UNIT - ETHER/USB/WIFI block
 (Sheet 3) : SCHEMATIC DIAGRAMS (3/7), 1U-3846 MAIN UNIT - ANALOG AUDIO IF/CODEC block
 (Sheet 4) : SCHEMATIC DIAGRAMS (4/7), 1U-3846 MAIN UNIT - SYSTEM uCOM block

1U-3859 POWER/iPOD dock UNIT

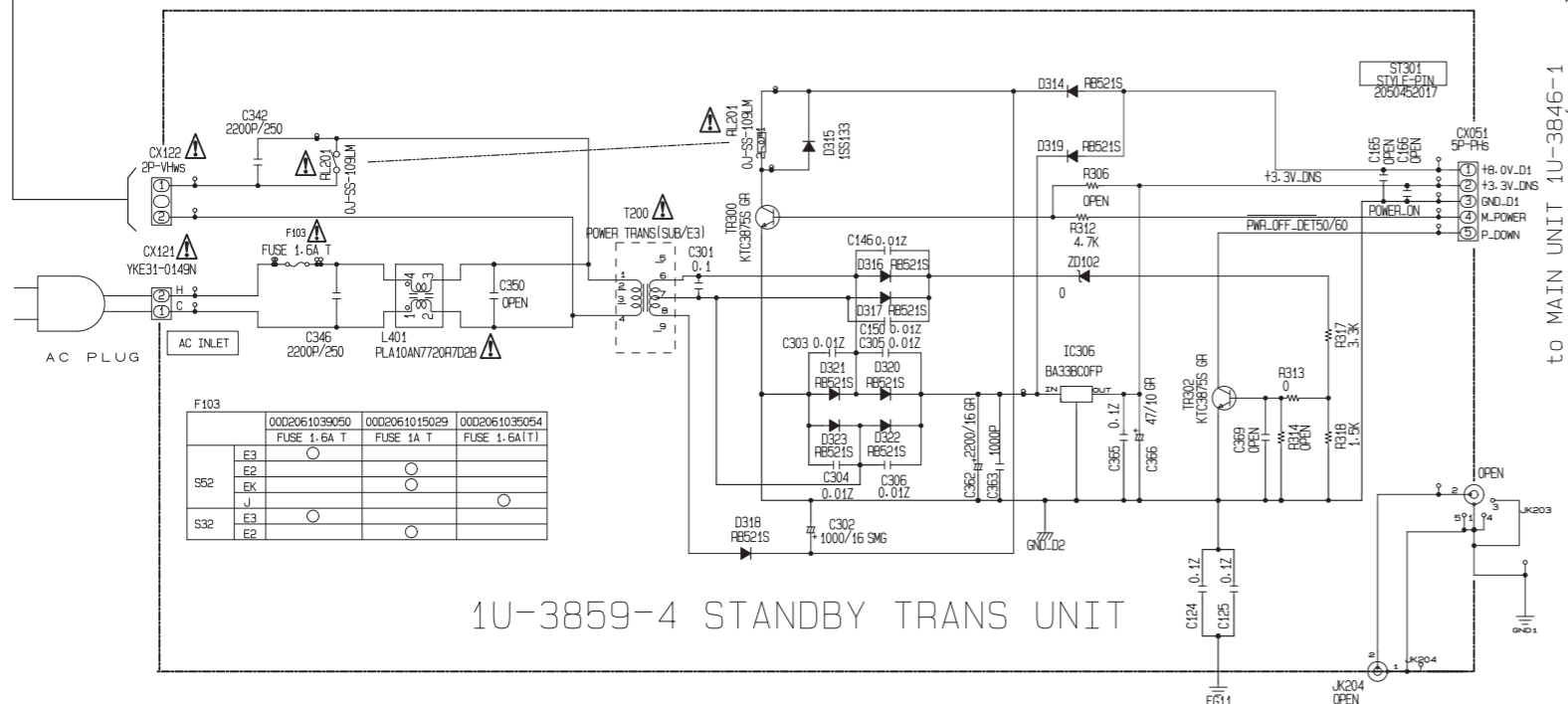

1U-3859-4 STANDBY TRANS UNIT

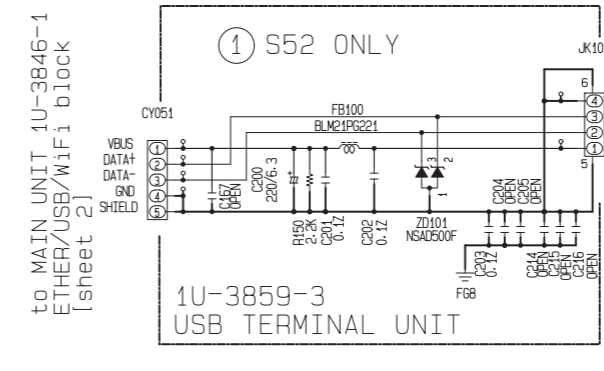

1U-3859-3 USB TERMINAL UNIT (S-52 ONLY)

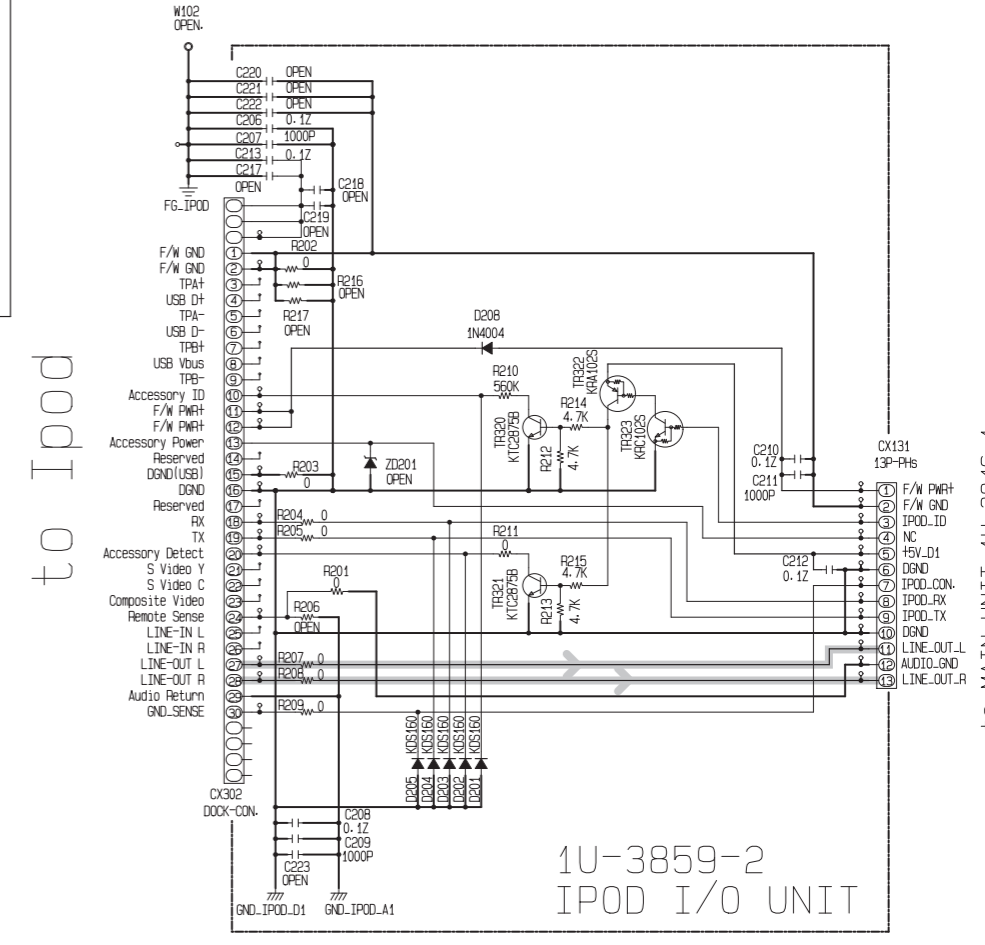

1U-3859-2 IPOD I/O UNIT

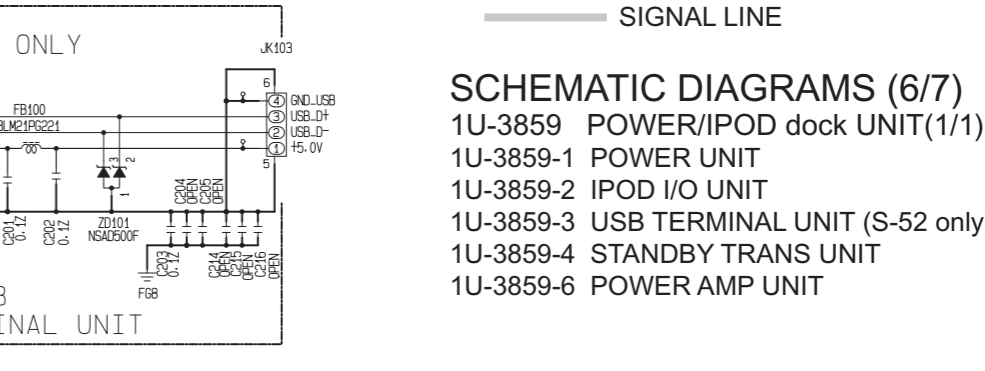

1U-3859-6 POWER AMP UNIT

- SCHMATIC DIAGRAMS (6/7)
- 1U-3859 POWER/iPOD dock UNIT(1/1)
 - 1U-3859-1 POWER UNIT
 - 1U-3859-2 IPOD I/O UNIT
 - 1U-3859-3 USB TERMINAL UNIT (S-52 only)
 - 1U-3859-4 STANDBY TRANS UNIT
 - 1U-3859-6 POWER AMP UNIT

to DVD DRIVE UNIT
 to MAIN UNIT 1U-3846-1 SYSTEM uCOM block (sheet 4)

to IPOD

to MAIN UNIT 1U-3846-1 SYSTEM uCOM block (sheet 4)

to MAIN UNIT 1U-3846-1 ETHER/USB/WIFI block (sheet 2)

to MAIN UNIT 1U-3846-1 ANALOG AUDIO IF/CODEC block (sheet 3)

to SP UNIT

to MAIN UNIT 1U-3846-1 ANALOG AUDIO IF/CODEC block (sheet 3)

F

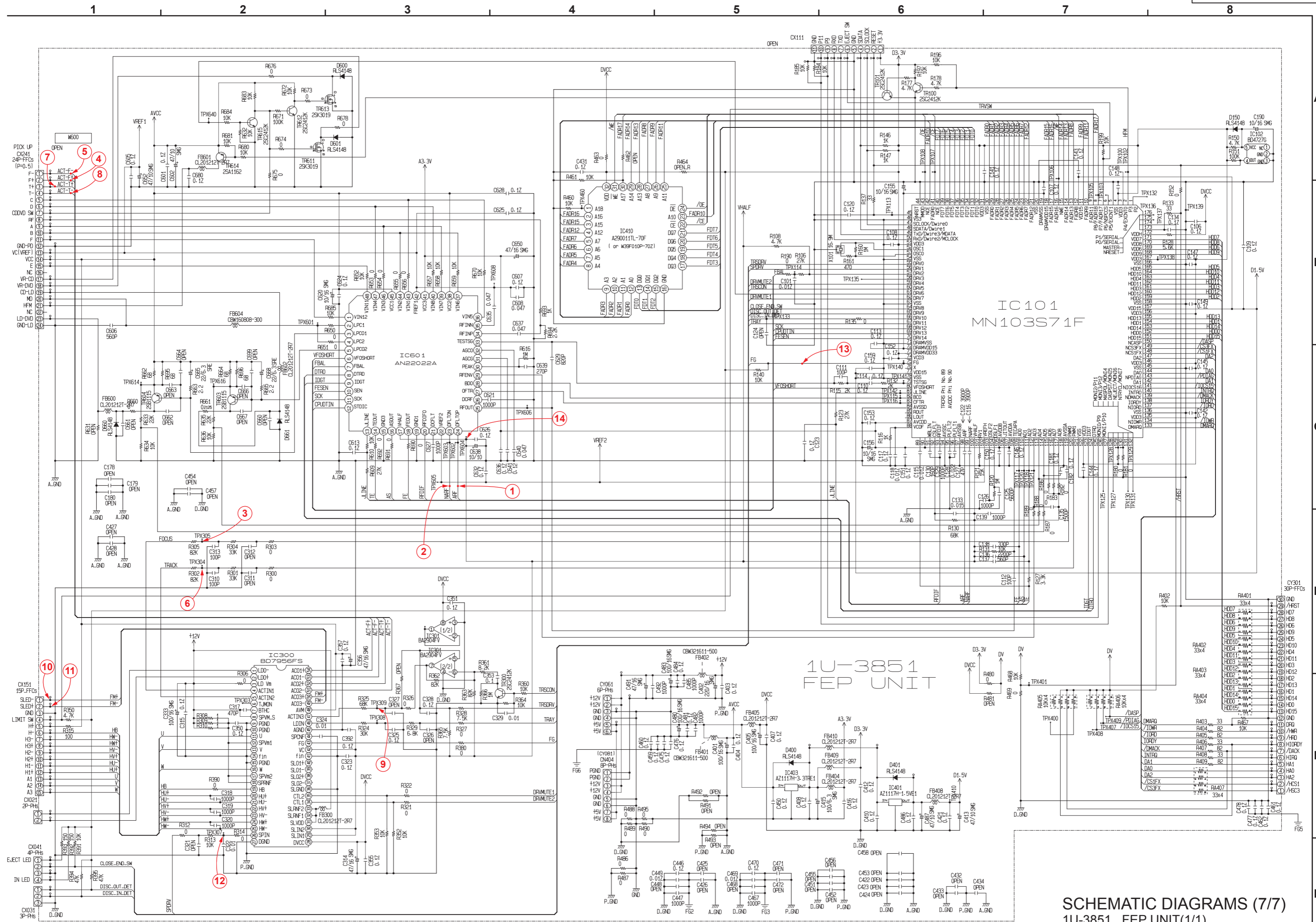

SCHEMATIC DIAGRAMS (7/7)
1U-3851 FEP UNIT(1/1)