

INTEGRATED NETWORK AV RECEIVER

AVR-X6700H

INTEGRATED NETWORK AV AMPLIFIER

AVC-X6700H

- For purposes of improvement, specifications and design are subject to change without notice.
- Please use this service manual when referring to the operating instructions without fail.
- Some illustrations used in this service manual are slightly different from the actual product.

[Click here!](#)

On-line service parts list

AVR-X6700H: <https://dmedia.soundunited.com/documents/details/27004>AVC-X6700H: <https://dmedia.soundunited.com/documents/details/27005>[ONLINE PARTS LIST \(P5\)](#)

WEB owner's manual

NA: <http://manuals.denon.com/AVRX6700H/NA/EN/index.php>EU: <http://manuals.denon.com/AVCX6700H/EU/EN/index.php>AP: <http://manuals.denon.com/AVCX6700H/AP/ZH/index.php>JP: <http://manuals.denon.com/AVCX6700H/JP/JA/index.php>

Upload is planned for the time of a future press release.

BEFORE SERVICING THIS UNIT

ELECTRICAL

MECHANICAL

REPAIR INFORMATION

UPDATING

Confidential

BEFORE SERVICING THIS UNIT

SAFETY PRECAUTIONS

NOTE FOR SCHEMATIC DIAGRAM

HANDLING THE SEMICONDUCTOR AND OPTICS

ONLINE PARTS LIST

[Accessing the Parts List](#)

[Searching Part Numbers or Ref. Numbers](#)

NOTE FOR PARTS LIST

SERIAL NUMBER

[Serial Number Organization](#)

[SKU Code of this Unit](#)

Sound mode table

[Sound modes and channel output](#)

[Sound modes and surround parameters](#)

[Types of input signals, and corresponding sound modes](#)

POST-SERVICE PRECAUTIONS

[Initializing this Unit](#)

JIG FOR SERVICING

SAFETY PRECAUTIONS

The following items should be checked for continued protection of the customer and the service technician.

Leakage current check

Before returning the set to the customer, be sure to carry out either (1) a leakage current check or (2) a line to chassis resistance check. If the leakage current exceeds 0.5 milliamps, or if the resistance from chassis to either side of the power cord is less than 460 kohms, the set is defective.

Be sure to test for leakage current with the AC plug in both polarities, in addition, when the set's power is in each state (on, off and standby mode), if applicable.

CAUTION

Please heed the following cautions and instructions during servicing and inspection.

⊙ Heed the cautions!

Cautions which are delicate in particular for servicing are labeled on the cabinets, the parts and the chassis, etc. Be sure to heed these cautions and the cautions described in the handling instructions.

⊙ Cautions concerning electric shock!

- (1) An AC voltage is impressed on this set, so if you touch internal metal parts when the set is energized, you may get an electric shock. Avoid getting an electric shock, by using an isolating transformer and wearing gloves when servicing while the set is energized, or by unplugging the power cord when replacing parts, for example.
- (2) There are high voltage parts inside. Handle with extra care when the set is energized.

⊙ Caution concerning disassembly and assembly!

Through great care is taken when parts were manufactured from sheet metal, there may be burrs on the edges of parts. The burrs could cause injury if fingers are moved across them in some rare cases. Wear gloves to protect your hands.

⊙ Use only designated parts!

The set's parts have specific safety properties (fire resistance, voltage resistance, etc.). Be sure to use parts which have the same properties for replacement. The burrs have the same properties. In particular, for the important safety parts that are indicated by the \triangle mark on schematic diagrams and parts lists, be sure to use the designated parts.

⊙ Be sure to mount parts and arrange the wires as they were originally placed!

For safety reasons, some parts use tapes, tubes or other insulating materials, and some parts are mounted away from the surface of printed circuit boards. Care should also be taken with the positions of the wires by arranging them and using clamps to keep them away from heating and high voltage parts, so be sure to set everything back as it was originally placed.

⊙ Make a safety check after servicing!

Check that all screws, parts and wires removed or disconnected when servicing have been put back in their original positions, check that no serviced parts have deteriorated the area around. Then make an insulation, check on the external metal connectors and between the blades of the power plug. And otherwise check that safety is ensured.

(Insulation check procedure)

Unplug the power cord from the power outlet, disconnect the antenna, plugs, etc., and on the power.

Using a 500V insulation resistance tester, check that the insulation resistance value between the inplug and the externally exposed metal parts (antenna terminal, headphones terminal, input terminal, etc.) is 1M Ω or greater. If it is less, the set must be inspected and repaired.

CAUTION

Concerning important safety parts

Many of the electric and the structural parts used in the set have special safety properties. In most cases these properties are difficult to distinguish by sight, and the use of replacement parts with higher ratings (rated power and withstand voltage) does not necessarily guarantee that safety performance will be preserved. Parts with safety properties are indicated as shown below on the wiring diagrams and the parts list in this service manual. Be sure to replace them with the parts which have the designated part number.

- (1) Schematic diagrams Indicated by the \triangle mark.
- (2) Parts lists Indicated by the \triangle mark.

The use of parts other than the designated parts could cause electric shocks, fires or other dangerous situations.

NOTE FOR SCHEMATIC DIAGRAM

WARNING:

Parts indicated by the \triangle mark have critical characteristics. Use ONLY replacement parts recommended by the manufacturer.

CAUTION:

Before returning the set to the customer, be sure to carry out either (1) a leakage current check or (2) a line to chassis resistance check. If the leakage current exceeds 0.5 milliamps, or if the resistance from chassis to either side of the power cord is less than 460 kohms, the set is defective.

WARNING:

DO NOT return the set to the customer unless the problem is identified and remedied.

NOTICE:

- (1) ALL RESISTANCE VALUES IN OHM. k=1,000 OHM / M=1,000,000 OHM
- (2) ALL CAPACITANCE VALUES ARE EXPRESSED IN MICRO FARAD, UNLESS OTHERWISE INDICATED. P INDICATES MICRO-MICRO FARAD. N INDICATES NANO FARAD.
- (3) EACH VOLTAGE AND CURRENT ARE MEASURED AT NO SIGNAL INPUT CONDITION.
- (4) CIRCUIT AND PARTS ARE SUBJECT TO CHANGE WITHOUT PRIOR NOTICE.

HANDLING THE SEMICONDUCTOR AND OPTICS

Electrostatic breakdown of the semi-conductors or optical pickup may occur due to a potential difference caused by electrostatic charge during unpacking or repair work.

1. Ground for Human Body

Be sure to wear a grounding band (1 M ohm) that is properly grounded to remove any static electricity that may be charged on the body.

2. Ground for Workbench

Be sure to place a conductive sheet or copper plate with proper grounding (1 M ohm) on the workbench or other surface, where the semi-conductors are to be placed. Because the static electricity charge on clothing will not escape through the body grounding band, be careful to avoid contacting semi-conductors with your clothing

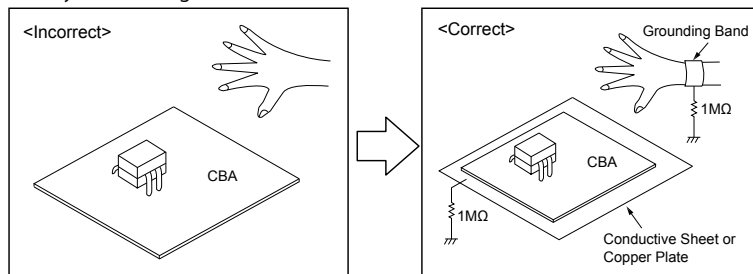

ONLINE PARTS LIST

Accessing the Parts List

- (1) Access from the Service Manual
 - Click the URL link on the cover of the service manual.
Examples of display



NOTE: If the web browser does not open automatically, copy the URL and paste it into the address bar of the web browser and then press Enter.

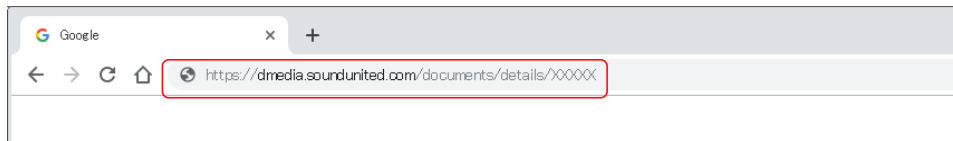

- (2) Accessing the Part List from the Model Asset Screen.
 - Display Model Asset from New SDI.
 - Click the section displayed as ▼ Link to Part Lists under the model name.

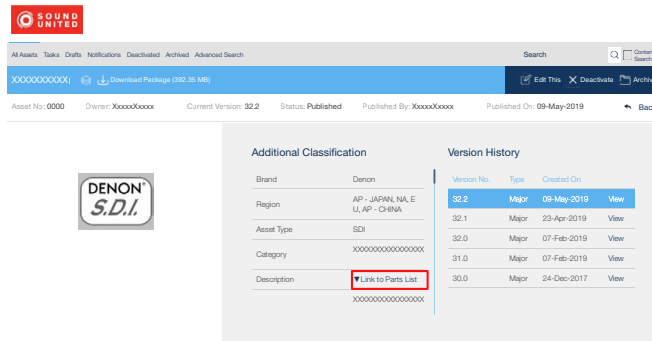

NOTE: If the ▼ Link to Parts List section is not displayed, download the parts table from the Asset list.

Searching Part Numbers or Ref. Numbers

You can search a Parts List for part numbers or Ref. numbers.

- (1) Enter the part number or Ref. number in the search window of the Parts List, and press the search button.
- (2) The search results are displayed.
The name of the sheet in which the search part is used and the part's line are displayed.

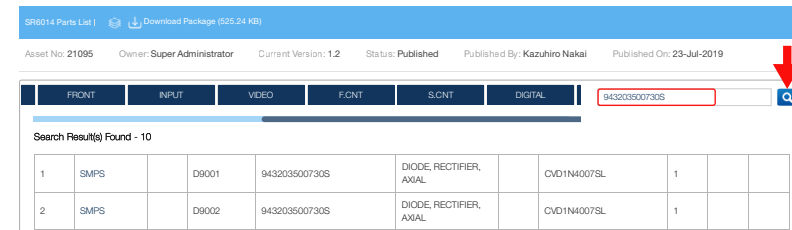

- (3) Next, click the "Sheet" section of the search results.

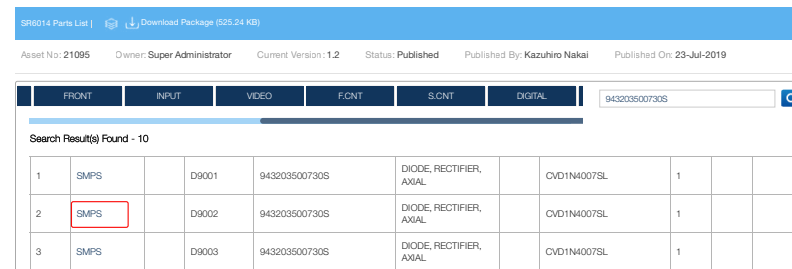

NOTE FOR PARTS LIST

- Parts indicated by "nsp" on this table cannot be supplied.
 - When ordering a part, make a clear distinction between "1" and "l" (i) to avoid mis-supplying.
 - A part ordered without specifying its part number can not be supplied.
 - Part indicated by "@" mark is not illustrated in the exploded and packaging view.
- WARNING:** Parts indicated by the ⚠ mark have critical characteristics. Use ONLY replacement parts recommended by the manufacturer.

SERIAL NUMBER

Serial Number Organization

The 13-digit serial number that contains the code of the manufacturing date.

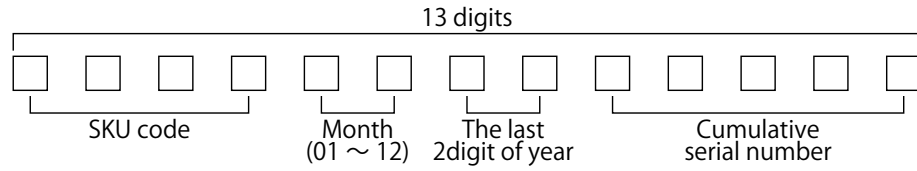

SKU Code of this Unit

Product SKU	SKU Code
AVRX6700HBKE3	DBCY
AVCX6700HBKE2	DBCZ
AVCX6700HSPE2	DBCX
AVCX6700HBKE1C	BCV
AVCX6700HK	BCW

Sound mode table

Sound modes and channel output

- This indicates the audio output channels or surround parameters that can be set.
- ⊙ This indicates the audio output channels. The output channels depend on the settings of “Speaker Config.”.

Sound mode	Channel output																	
	Front L/R	Center	Surround L/R	Surround Back L/R	Front Wide L/R	Front Height L/R	Top Front L/R	Top Middle L/R	Top Rear L/R	Rear Height L/R	Surround Height L/R	Center Height	Top Surround	Front Dolby Atmos Enabled L/R	Surround Dolby Atmos Enabled L/R	Back Dolby Atmos Enabled L/R	Subwoofer	
Direct/Pure Direct (2-channel)	○																⊙※ 5	
Direct/Pure Direct (Multi-channel)	○	⊙	⊙	⊙※ 6	⊙※ 6	⊙※ 6	⊙※ 6	⊙※ 6	⊙※ 6	⊙※ 6	⊙※ 6	⊙※ 6	⊙※ 6	⊙※ 6	⊙※ 6	⊙※ 6	⊙※ 6	⊙
DSD Direct (2-channel)	○																⊙※ 5	
DSD Direct (Multi-channel)	○	⊙	⊙														⊙	
Stereo	○																⊙	
Dolby Atmos	○	⊙	⊙	⊙	⊙	⊙	⊙	⊙	⊙	⊙				⊙	⊙	⊙	⊙	
Dolby TrueHD	○	⊙	⊙	⊙※ 6													⊙	
Dolby Digital Plus	○	⊙	⊙	⊙※ 6													⊙	
Dolby Digital	○	⊙	⊙														⊙	
Dolby Surround ※ 1	○	⊙	⊙	⊙※ 7	⊙※ 8	⊙	⊙	⊙	⊙	⊙				⊙	⊙	⊙	⊙	
IMAX DTS:X ※ 2	○	⊙	⊙	⊙	⊙	⊙	⊙	⊙	⊙	⊙	⊙	⊙		⊙	⊙	⊙	⊙	
IMAX DTS	○	⊙	⊙※ 9	⊙※ 9													⊙	
DTS:X ※ 2	○	⊙	⊙	⊙	⊙	⊙	⊙	⊙	⊙	⊙	⊙	⊙		⊙	⊙	⊙	⊙	
DTS-HD	○	⊙	⊙	⊙※ 6	⊙※ 6												⊙	
DTS Express	○	⊙	⊙	⊙													⊙	
DTS 96/24	○	⊙	⊙	⊙													⊙	
DTS Surround	○	⊙	⊙	⊙													⊙	
DTS Neural:X ※ 3	○	⊙	⊙	⊙	⊙	⊙	⊙	⊙	⊙	⊙	⊙	⊙		⊙	⊙	⊙	⊙	
DTS Virtual:X ※ 4	○	⊙	⊙	⊙													⊙	
Auro-3D	○	⊙	⊙	⊙		⊙				⊙※ 10	⊙	⊙	⊙	⊙※ 11	⊙※ 11	⊙※ 11	⊙	
Auro-2D Surround	○	⊙	⊙	⊙													⊙	
Multi Ch In	○	⊙	⊙	⊙※ 6													⊙	
MPEG-2 AAC (JAPAN Model Only)	○	⊙	⊙														⊙	
MPEG-4 AAC (JAPAN Model Only)	○	⊙	⊙														⊙	
Multi Ch Stereo	○	⊙	⊙	⊙	⊙※ 12	⊙※ 12	⊙※ 12	⊙※ 12	⊙※ 12	⊙※ 12	⊙※ 12	⊙※ 12	⊙※ 12	⊙※ 12	⊙※ 12	⊙※ 12	⊙	
Rock Arena	○	⊙	⊙	⊙	⊙※ 12	⊙※ 12	⊙※ 12	⊙※ 12	⊙※ 12	⊙※ 12	⊙※ 12	⊙※ 12	⊙※ 12	⊙※ 12	⊙※ 12	⊙※ 12	⊙	
Jazz Club	○	⊙	⊙	⊙	⊙※ 12	⊙※ 12	⊙※ 12	⊙※ 12	⊙※ 12	⊙※ 12	⊙※ 12	⊙※ 12	⊙※ 12	⊙※ 12	⊙※ 12	⊙※ 12	⊙	
Mono Movie	○	⊙	⊙	⊙	⊙※ 12	⊙※ 12	⊙※ 12	⊙※ 12	⊙※ 12	⊙※ 12	⊙※ 12	⊙※ 12	⊙※ 12	⊙※ 12	⊙※ 12	⊙※ 12	⊙	
Video Game	○	⊙	⊙	⊙	⊙※ 12	⊙※ 12	⊙※ 12	⊙※ 12	⊙※ 12	⊙※ 12	⊙※ 12	⊙※ 12	⊙※ 12	⊙※ 12	⊙※ 12	⊙※ 12	⊙	
Matrix	○	⊙	⊙	⊙	⊙※ 12	⊙※ 12	⊙※ 12	⊙※ 12	⊙※ 12	⊙※ 12	⊙※ 12	⊙※ 12	⊙※ 12	⊙※ 12	⊙※ 12	⊙※ 12	⊙	
Virtual	○																⊙	

- ※ 1 The applicable sound mode includes “Dolby Surround” and sound modes that have “+Dolby Surround” in the sound mode name.
- ※ 2 Audio can be played through a maximum of 11-channels when 11 speakers or more (excluding the subwoofer) are installed.
- ※ 3 The applicable sound mode includes “DTS Neural:X” and sound modes that have “+Neural:X” in the sound mode name.
- ※ 4 The applicable sound mode includes “DTS Virtual:X” and sound modes that have “+Virtual:X” in the sound mode name.
- ※ 5 Audio is output when “Subwoofer Mode” in the menu is set to “LFE+Main”.
- ※ 6 A signal for each channel contained in an input signal is output as audio.
- ※ 7 Audio is not output when the “Speaker Virtualizer” in the menu is set to “On” and “Speaker Config.” - “Surr. Back” in the menu is set to “1 spkr”.
- ※ 8 Audio is not output when the “Speaker Virtualizer” is set to “On”.
- ※ 9 When “Speaker Config.” - “Surr. Back” is set to “2 spkrs”, “Speaker Config.” - “Center” is set to “Large” or “Small”, and sound mode is set to “IMAX DTS”, surround audio is output from the surround back speaker. Audio is not output from the surround speaker.
- ※ 10 For the best Auro-3D experience Surround Height speakers are recommended, however you may substitute Rear Height speakers from a Dolby Atmos speaker setup in place of Surround Height speakers.
- ※ 11 For the best Auro-3D experience Front Height and Surround Height speakers are recommended, however you may substitute Dolby Atmos Enabled speakers.
- ※ 12 Audio is output from the speakers specified in the “Surround Parameter” – “Speaker Select” settings.

Types of input signals, and corresponding sound modes

● This indicates the default sound mode. ○ This indicates the selectable sound mode.

Sound mode	NOTE	2-channel signal										Multi-channel signal																
		Dolby TrueHD	Dolby Digital Plus	Dolby Digital (EX)	DTS-HD	DTS Express	DTS	Analog / PCM	MPEG-2 AAC/ MPEG-4 AAC	DSD (Super Audio CD)	Dolby Atmos	Dolby TrueHD	Dolby Digital Plus	Dolby Digital (EX)	IMAX DTS:X	IMAX DTS	DTS:X	DTS-HD	DTS Express	DTS ES Dscrt6.1	DTS ES Mtrx6.1	DTS	Auro-3D	PCM multi-channel	MPEG-2 AAC/ MPEG-4 AAC	DSD (Super Audio CD)		
Direct																												
Direct		○	○	○	○	○	○	○※ 2	○																			
DSD Direct									○																			○
Pure Direct																												
Pure Direct		○	○	○	○	○	○	○	○																			
DSD Pure Direct									○																			○
Stereo																												
Stereo		○	○	○	○	○	○	●	○	●																		○
Dolby Surround																												
Dolby Atmos	※ 1										●																	
Dolby TrueHD		○									○※ 3	○													○※ 4			
Dolby Digital Plus			○								○※ 5																	
Dolby Digital				○									○															
Dolby (D+) (HD) + Dolby Surround												●	●	●											○※ 4			
Dolby (D+) (HD) + Neural:X												○	○	○											○※ 4			
Dolby Surround		●	●	●	○	○	○	○	○	●	○																	
DTS Surround																												
IMAX DTS:X														●※ 10														
IMAX DTS															○※ 10										○※ 11			
DTS:X MSTR / DTS:X														○※ 12		●												
DTS-HD MSTR							○※ 13								○※ 12		○※ 13								○※ 14			
DTS-HD HI RES							○※ 15								○※ 12		○※ 15											
DTS Express								○							○※ 12			○										
DTS ES Dscrt 6.1	※ 6																		○									
DTS ES Mtrx 6.1	※ 6																											
DTS 96/24									○※ 16																	○※ 16		
DTS Surround									○						○※ 12										○	○	○	○
IMAX DTS + Neural:X															●※ 10										○※ 11			
IMAX DTS / IMAX DTS:X + Virtual:X															○※ 10	○※ 10									○※ 11			
DTS (-HD) + Dolby Surround															○		○	○	○	○	○	○	○		○※ 14			
DTS (-HD) + Neural:X															○※ 12		●※ 7	●※ 7	●※ 7	●※ 7	●※ 7	●※ 7	●※ 7	○※ 14				
DTS (-HD) / DTS:X + Virtual:X															○※ 12	○※ 12	○※ 8	○	○	○	○	○	○	○※ 14				
DTS Neural:X		○	○	○	●※ 7	●※ 7	●※ 7	○	○	○	○																	
DTS Virtual:X									○	○	○																	
Auro-3D																												
Auro-3D	※ 17	○	○	○	○	○	○	○	○	○					○									○	○	○	○	○
Auro-2D Surround	※ 17	○	○	○	○	○	○	○	○	○					○									○	○	○	○	○
Multi Ch In																												
Multi Ch In																									○※ 18	●		●
Multi Ch In 7.1	※ 6																								○※ 19			
Multi In + Dolby Surround																									○			○
Multi In + Neural:X																									○			○
Multi In + Virtual:X																									○			○
MPEG-2 AAC/MPEG-4 AAC (JP Only)																												
MPEG-2 AAC											○※ 21																○※ 21	
MPEG-4 AAC											○※ 22																○※ 22	
AAC + Dolby Surround																											○	
AAC + Neural:X																											●	
AAC + Virtual:X																											○	
Original sound mode																												
Multi Ch Stereo		○	○	○	○	○	○	○	○	○	○																	○
Rock Arena		○	○	○	○	○	○	○	○	○	○※ 20	○	○	○	○	○	○	○	○	○	○	○	○	○	○	○	○	○
Jazz Club		○	○	○	○	○	○	○	○	○	○※ 20	○	○	○	○	○	○	○	○	○	○	○	○	○	○	○	○	○
Mono Movie		○	○	○	○	○	○	○	○	○	○※ 20	○	○	○	○	○	○	○	○	○	○	○	○	○	○	○	○	○
Video Game		○	○	○	○	○	○	○	○	○	○※ 20	○	○	○	○	○	○	○	○	○	○	○	○	○	○	○	○	○
Matrix		○	○	○	○	○	○	○	○	○	○※ 20	○	○	○	○	○	○	○	○	○	○	○	○	○	○	○	○	○
Virtual		○	○	○	○	○	○	○	○	○	○※ 20	○	○	○	○	○	○	○	○	○	○	○	○	○	○	○	○	○

- ※ 1 This item can be selected when using any of the Surround Back, Front Height, Top Front, Top Middle, Top Rear, Rear Height, Front Dolby, Surround Dolby or Back Dolby speaker. It can also be selected when the "Speaker Virtualizer" setting is turned "On".
- ※ 2 The default sound mode for the AirPlay playback is "Direct".
- ※ 3 This can be selected when the Dolby Atmos signal contains the Dolby TrueHD signal.
- ※ 4 This item can be selected if the Auro-3D signal contains Dolby TrueHD.
- ※ 5 This can be selected when the Dolby Atmos signal contains the Dolby Digital Plus signal.
- ※ 6 This item can be selected when surround back speakers are used.
- ※ 7 This item cannot be selected when a DTS(-HD) format with a sampling frequency of over 48 kHz is input.
- ※ 8 This item cannot be selected when a DTS:X format with a sampling frequency of over 48 kHz is input.
- ※ 9 This item cannot be selected when the input signal is Dolby Digital, Dolby Digital Plus, Dolby TrueHD or Dolby Atmos.
- ※ 10 Selectable when "Surround Parameter" - "IMAX" is set to "Auto" in the menu.
- ※ 11 Selectable when "Surround Parameter" - "IMAX" is set to "On" in the menu and a 48 kHz sampling frequency DTS 5.1 channel signal is being input.
- ※ 12 Selectable when "Surround Parameter" - "IMAX" is set to "Off". (Selectable sound modes vary depending on the type of input signal).
- ※ 13 This item can be selected when the input signal is DTS-HD Master Audio.
- ※ 14 This item can be selected if the Auro-3D signal contains DTS-HD Master Audio.
- ※ 15 This item can be selected when the input signal is DTS-HD Hi Resolution.
- ※ 16 This item can be selected when the input signal is DTS 96/24.
- ※ 17 This item cannot be selected if the sampling frequency of the input signal is 32 kHz.
- ※ 18 This item can be selected if the Auro-3D signal contains Multi Channel PCM.
- ※ 19 This item can be selected when the input signals contain surround back signals.
- ※ 20 This can be selected when the Dolby Atmos signal contains the Dolby TrueHD or Dolby Digital Plus signal.
- ※ 21 This item can be selected when input signal is MPEG-2 AAC
- ※ 22 This item can be selected when input signal is MPEG-4 AAC

POST-SERVICE PRECAUTIONS

Initializing this Unit

Make sure to initialize this unit after replacing the microcomputer or any peripheral equipment, or the digital PCB.

1. Press the power button to turn off the power.
2. While holding down buttons "INFO" and "SETUP" simultaneously, press the power button to turn on the power.
3. Release the buttons after confirming that the display flashes at 1-second intervals.
 - * The unit is initialized.Use network initialization mode to initialize the network related settings.

NOTE :

- If the unit fails to enter the service mode in step 3, repeat the procedure from step 1.
- Initializing the device restores the customized settings to the factory settings. Write down your settings in advance and reconfigure the settings after initialization.

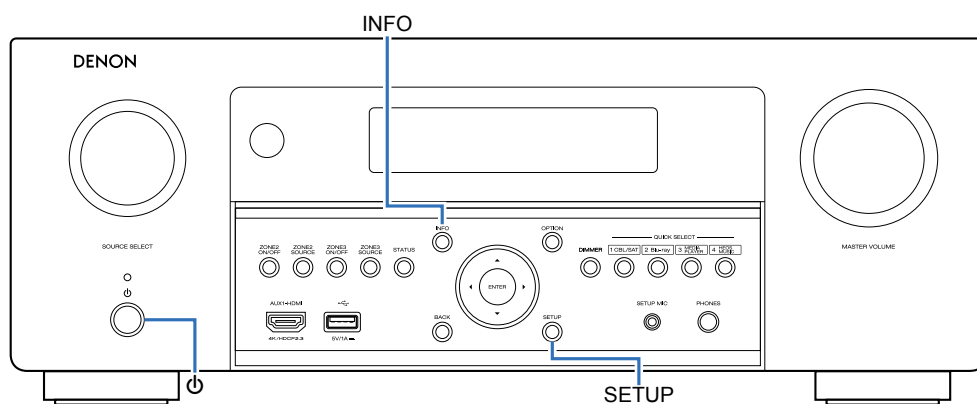

JIG FOR SERVICING

Use the following jigs (extension cable kit) when repairing the PCBs.
Order with your dealer for the jigs your dealer if necessary.

8U-110084S : EXTENSION UNIT KIT : 1 Set
(See [JIG FOR SERVICING](#))

ELECTRICAL

SCHEMATIC DIAGRAMS

SCH01 DIG DIGITAL CONNECT
SCH02 DIG MAIN CPU
SCH03 DIG EXPANDER
SCH04 DIG DIR DA SUPPLY
SCH05 DIG DSP1(Griffin Lite)
SCH06 DIG DSP2(Griffin Lite)
SCH07 DIG AUDIO PLD
SCH08 DIG HDMI SUPPLY
SCH09 DIG DECODER(ADV7180)
SCH10 DIG DECODER(ADV7850)
SCH11 DIG IP OSD(ADV8003)
SCH12 DIG IP OSD DDR
SCH13 DIG VIDEO PLD
SCH14 DIG HDMI SW2 Rx(MN864788)
SCH15 DIG HDMI SW1 Rx & Z2out(MN864788)
SCH16 DIG HDMI TX(MN864807)
SCH17 DIG NET MODULE CONNECT
SCH18 SPK SIDE CONNECT
SCH19 DAC ADC ZONEDAC
SCH20 DAC 13ch MainDAC
SCH21 AV REAR INPUT
SCH22 AV CONNECT
SCH23 AV AUDIO VIDEO CONNECT
SCH24 AV AUDIO VIDEO VOLUME
SCH25 AV AUDIO VIDEO PREOUT
SCH26 AV AUDIO VIDEO VIDEO
SCH27 P.AMP POWER AMP-1
SCH28 P.AMP POWER AMP-2
SCH29 P.AMP POSISTER
SCH30 SPK AMP CONNECT

SCH31 SPK SPEAKER(1-2)
SCH32 SPK SPEAKER(2-2)
SCH33 AV PROTECTION
SCH34 AV SMPS
SCH35 FLD
SCH36 DAC HP MIC
SCH37 DAC FRONT HDMI USB

PRINTED CIRCUIT BOARDS

DIGITAL
AUDIO VIDEO, PROTECTION, CONNECT-1, TUNER
IN(AVC model Only), CONNECT-4, CONNECT-2, SMPS
REAR INPUT, DAC, H/P MIC, FRONT USB, FRONT
HDMI
SPEAKER, HIGHT2, HIGHT3, HIGHT4, SIDE CONNECT
L AMP CONNECT, R AMP CONNECT, P.AMP-1,
P.AMP-2, POSISTER-1, FLD, VOLUME, SOURCE SEL,
P.SW, CONNECT, COVER

LEVEL DIAGRAM

FRONT ch
CENTER ch
SUBWOOFER ch
SURROUND ch
SURR.BACK ch
HEIGHT ch
ZONE2/3 ch

BLOCK DIAGRAM

ANALOG AUDIO DIAGRAM
DIGITAL AUDIO DIAGRAM
VIDEO DIAGRAM

POWER DIAGRAM

SEMICONDUCTORS

1. IC's
2. FL DISPLAY
3. Remote Code Table

SCHEMATIC DIAGRAMS

SCH01 DIG DIGITAL CONNECT

All Ref.No. has been described in the parts list are four digits.
 But there are less than four digits of printed Ref.No. on the PCB, and they have become four digits after the header by adding "0" in the parts list.

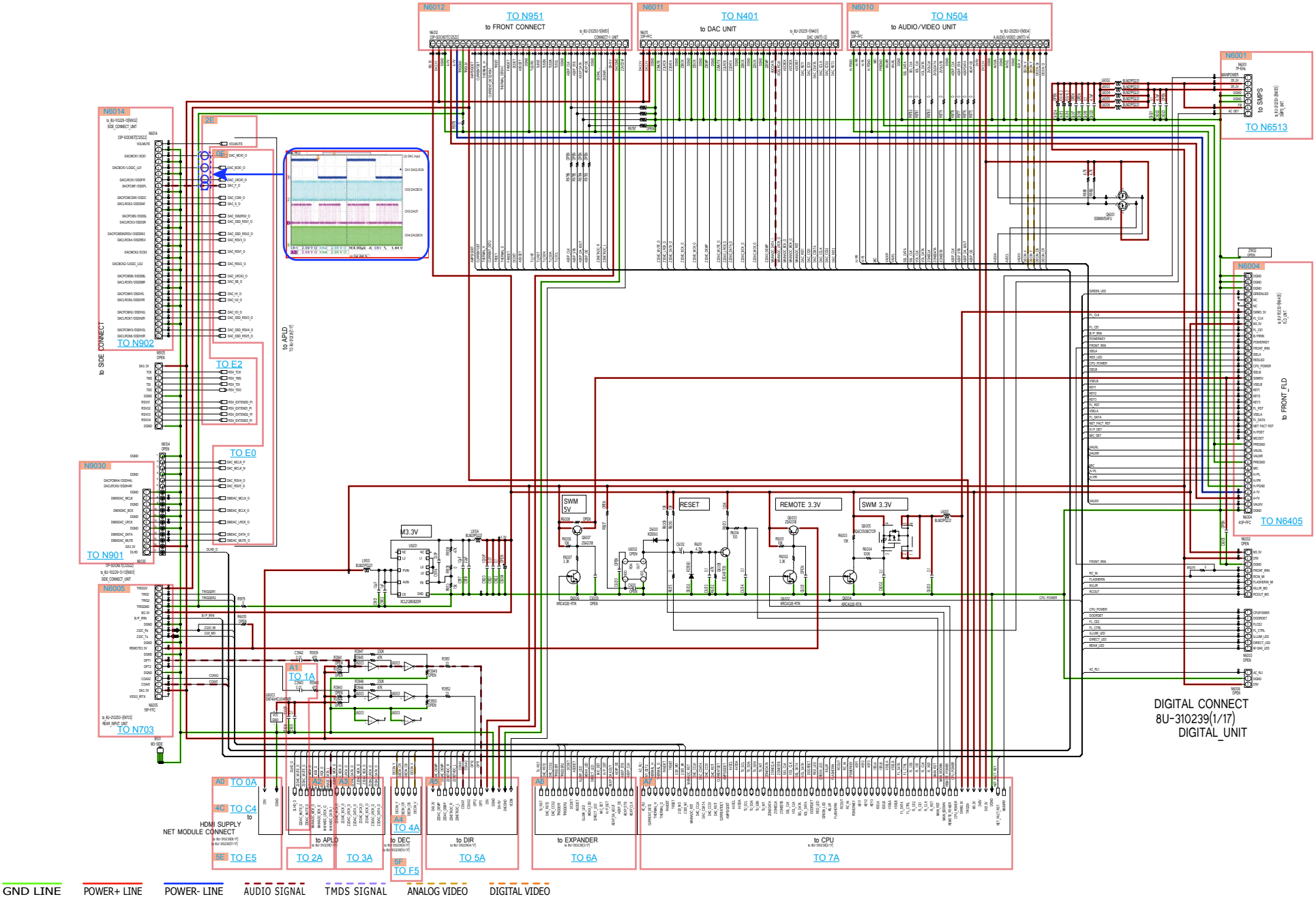

DIGITAL CONNECT
 8U-310239(1/17)
 DIGITAL_UNIT

GND LINE POWER+ LINE POWER- LINE AUDIO SIGNAL TMDS SIGNAL ANALOG VIDEO DIGITAL VIDEO

TO 0A
 TO C4
 TO E5
 TO 2A
 TO 3A
 TO 4A
 TO 5A
 TO 6A
 TO 7A

Before Servicing
 This Unit

Electrical

Mechanical

Repair Information

Updating

SCH02 DIG MAIN CPU

All Ref.No. has been described in the parts list are four digits.
But there are less than four digits of printed Ref.No. on the PCB, and they have become four digits after the header by adding "0" in the parts list.

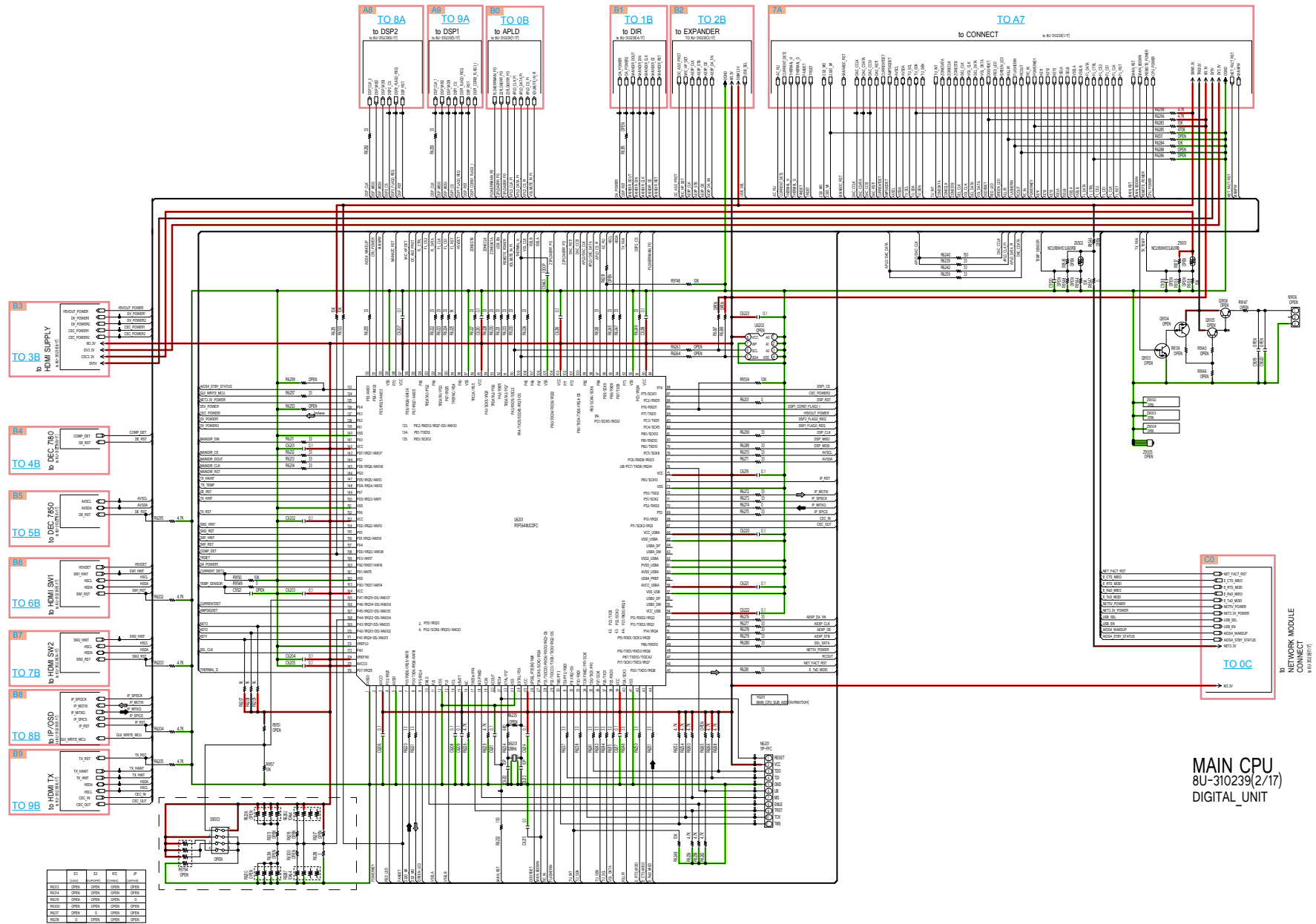

GND LINE POWER+ LINE POWER- LINE AUDIO SIGNAL TMDS SIGNAL ANALOG VIDEO DIGITAL VIDEO

MAIN CPU
8U-310239(2/17)
DIGITAL_UNIT

Before Servicing
This Unit

Electrical

Mechanical

Repair Information

Updating

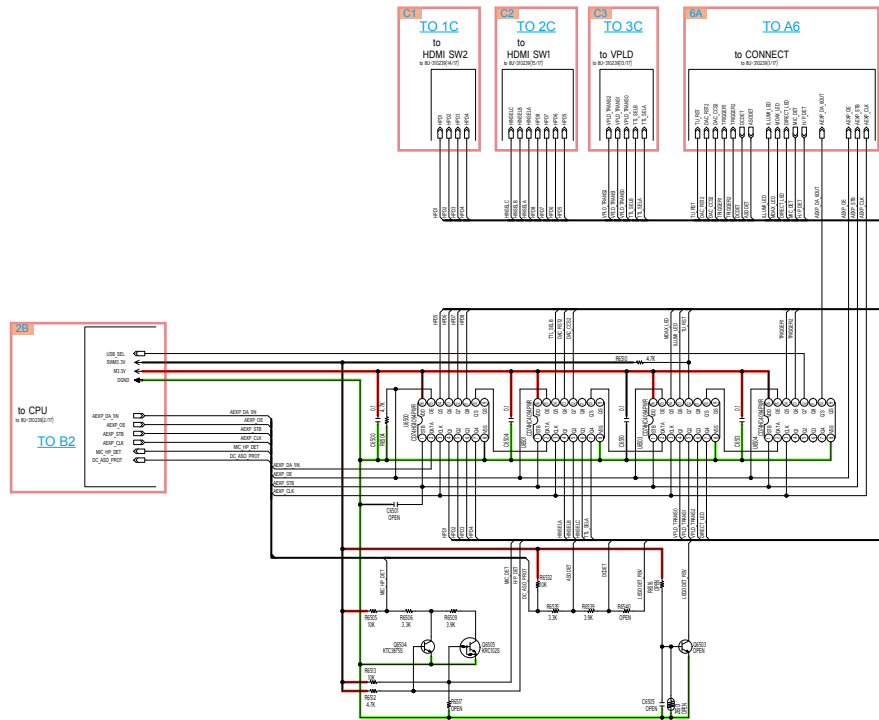

— GND LINE
 — POWER+ LINE
 — POWER- LINE
 — AUDIO SIGNAL
 — TMDS SIGNAL
 — ANALOG VIDEO
 — DIGITAL VIDEO

SCH04 DIG DIR DA SUPPLY

All Ref.No. has been described in the parts list are four digits.
But there are less than four digits of printed Ref.No. on the PCB, and they have become four digits after the header by adding "0" in the parts list.

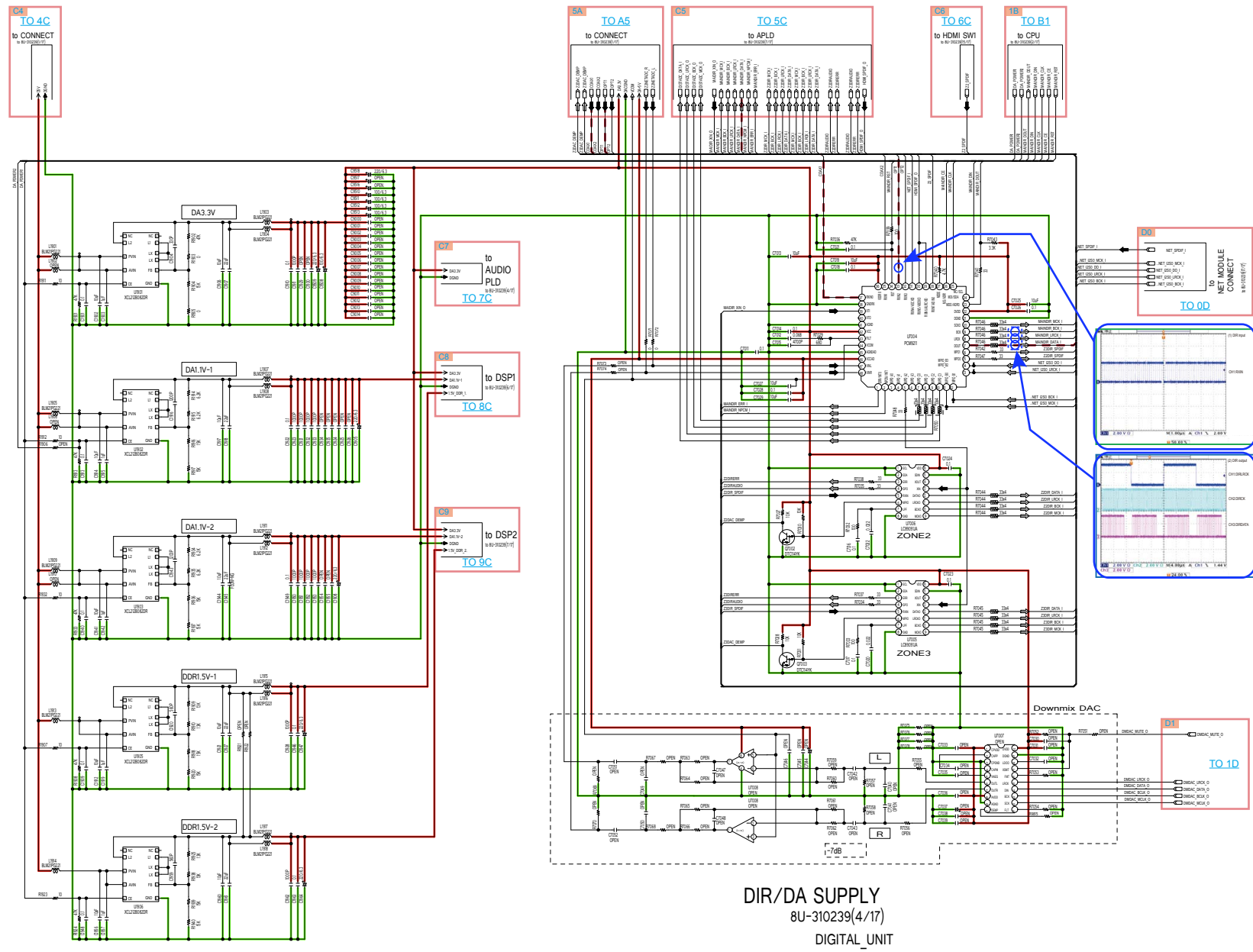

DIR/DA SUPPLY
8U-310239(4/17)
DIGITAL_UNIT

- GND LINE
- POWER+ LINE
- POWER- LINE
- AUDIO SIGNAL
- TMDS SIGNAL
- ANALOG VIDEO
- DIGITAL VIDEO

SCH06 DIG DSP2(Griffin Lite)

All Ref.No. has been described in the parts list are four digits.
 But there are less than four digits of printed Ref.No. on the PCB, and they have become four digits after the header by adding "0" in the parts list.

Before Servicing
This Unit

Electrical

Mechanical

Repair Information

Updating



GND LINE POWER+ LINE POWER- LINE AUDIO SIGNAL TMS SIGNAL ANALOG VIDEO DIGITAL VIDEO

SCH07 DIG AUDIO PLD

All Ref.No. has been described in the parts list are four digits.
 But there are less than four digits of printed Ref.No. on the PCB, and they have become four digits after the header by adding "0" in the parts list.

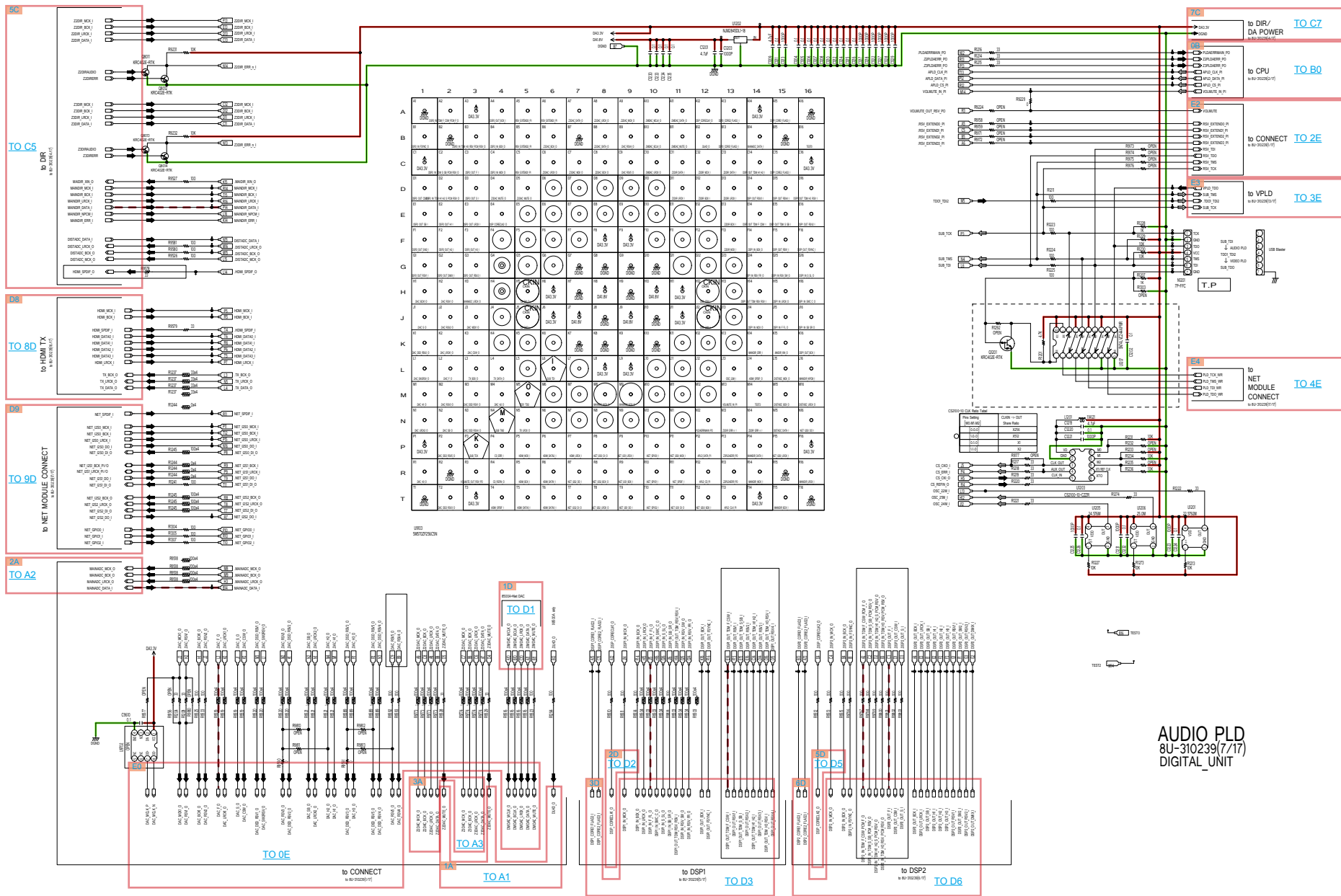

GND LINE POWER+ LINE POWER- LINE AUDIO SIGNAL TMD5 SIGNAL ANALOG VIDEO DIGITAL VIDEO

AUDIO PLD
 8U-310239(7/17)
 DIGITAL_UNIT

Before Servicing
 This Unit

Electrical

Mechanical

Repair Information

Updating

SCH08 DIG HDMI SUPPLY

All Ref.No. has been described in the parts list are four digits.
But there are less than four digits of printed Ref.No. on the PCB, and they have become four digits after the header by adding "0" in the parts list.

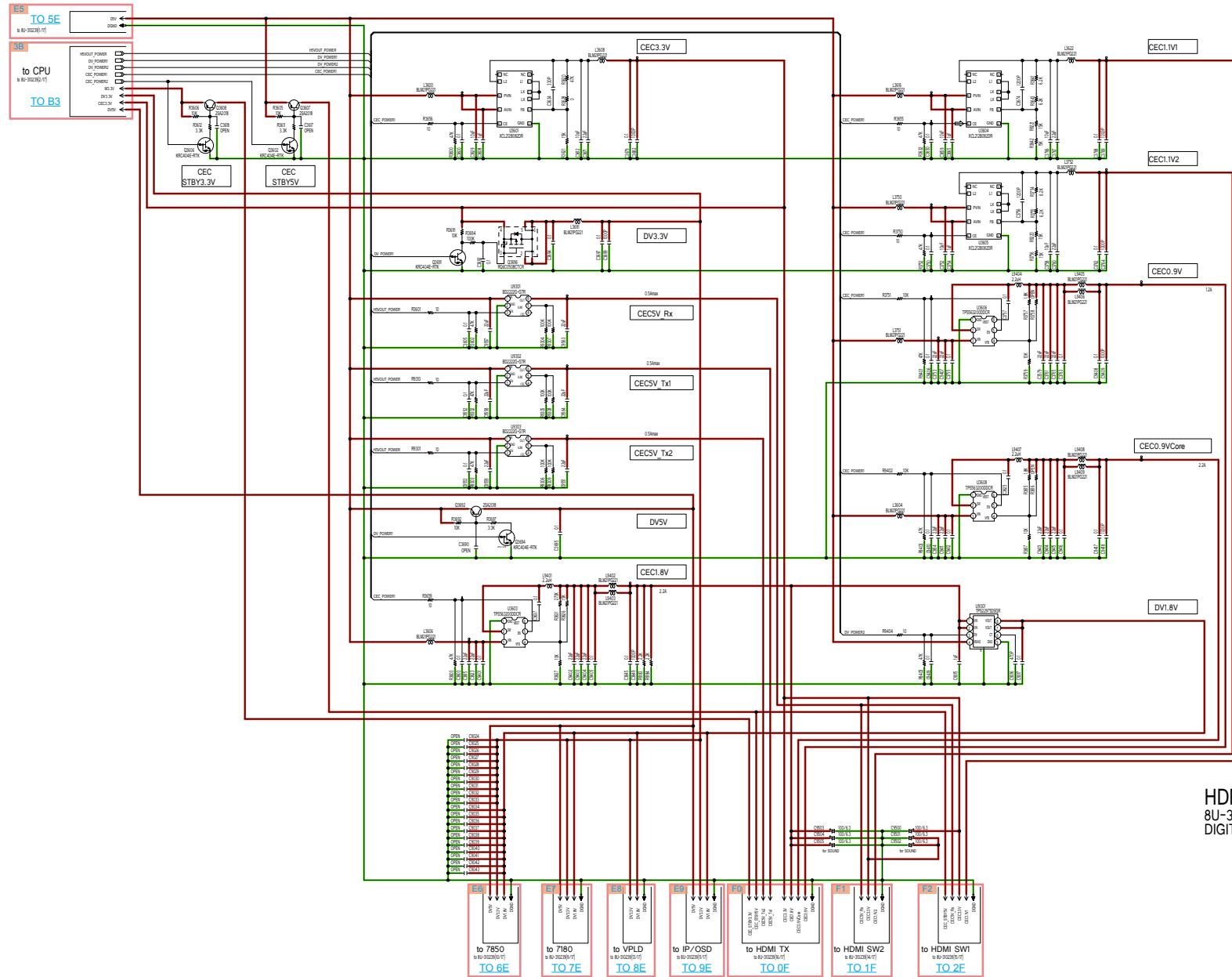

HDMI SUPPLY
8U-310239(8/17)
DIGITAL_UNIT

GND LINE POWER+ LINE POWER- LINE AUDIO SIGNAL TMDS SIGNAL ANALOG VIDEO DIGITAL VIDEO

SCH09 DIG DECODER(ADV7180)

All Ref.No. has been described in the parts list are four digits.
But there are less than four digits of printed Ref.No. on the PCB, and they have become four digits after the header by adding "0" in the parts list.

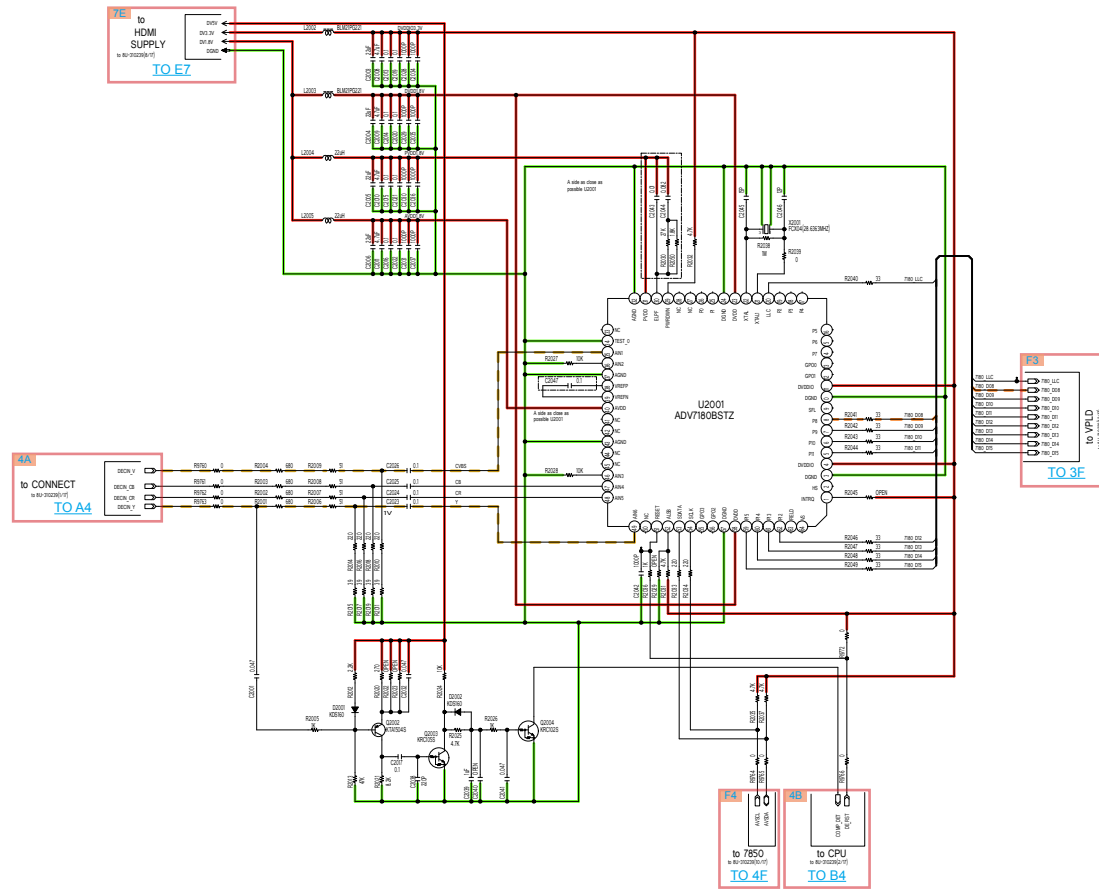

DECODER 7180
8U-310239(9/17)
DIGITAL_UNIT

GND LINE POWER+ LINE POWER- LINE AUDIO SIGNAL TMDS SIGNAL ANALOG VIDEO DIGITAL VIDEO

SCH10 DIG DECODER(ADV7850)

All Ref.No. has been described in the parts list are four digits.
 But there are less than four digits of printed Ref.No. on the PCB, and they have become four digits after the header by adding "0" in the parts list.

Before Servicing
This Unit

Electrical

Mechanical

Repair Information

Updating

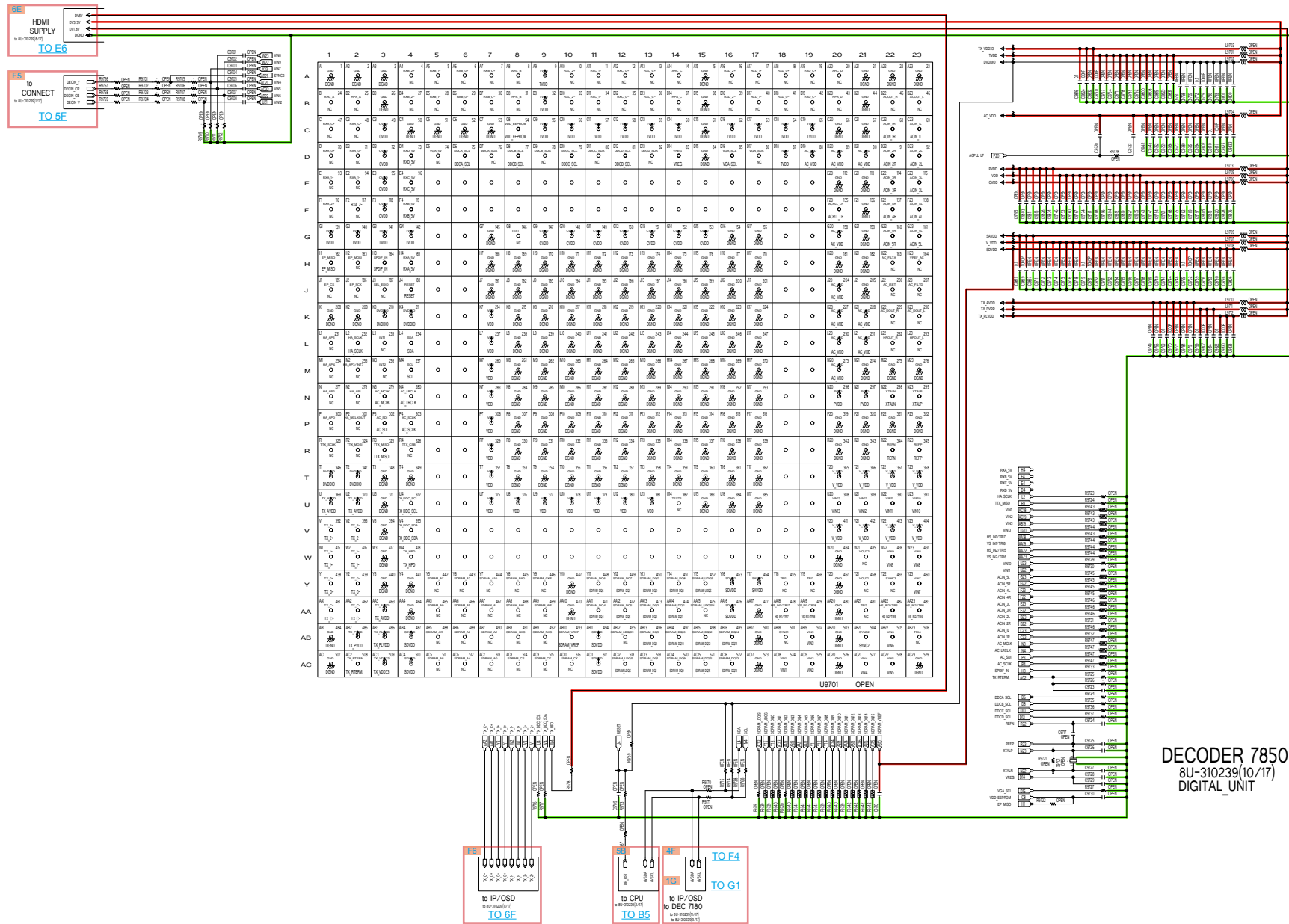

DECODER 7850
 8U-310239(10/17)
 DIGITAL UNIT

SCH11 DIG IP OSD(ADV8003)

All Ref.No. has been described in the parts list are four digits.
 But there are less than four digits of printed Ref.No. on the PCB, and they have become four digits after the header by adding "0" in the parts list.

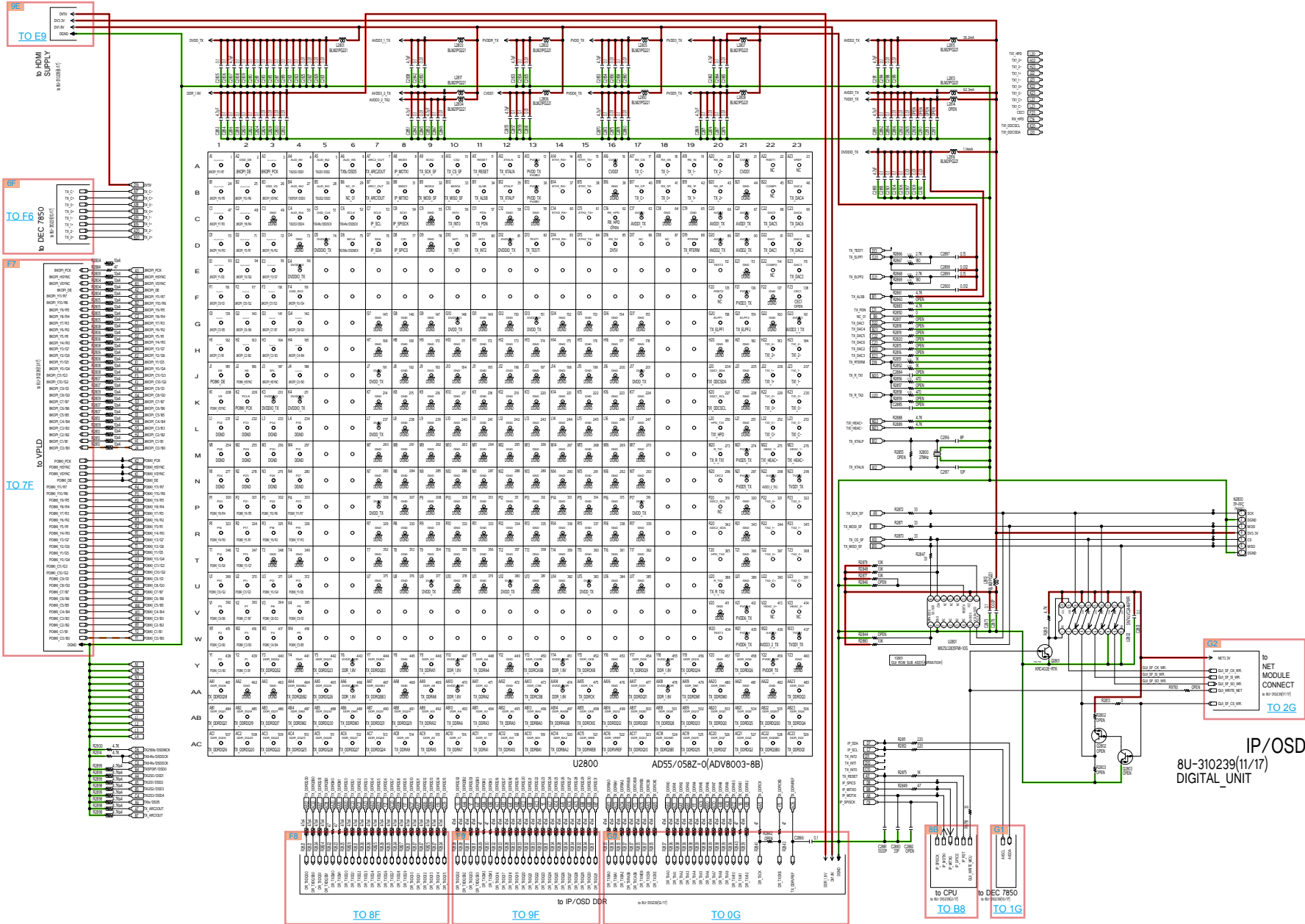

GND LINE POWER+ LINE POWER- LINE AUDIO SIGNAL TMDS SIGNAL ANALOG VIDEO DIGITAL VIDEO

Before Servicing
This Unit

Electrical

Mechanical

Repair Information

Updating

All Ref.No. has been described in the parts list are four digits.
 But there are less than four digits of printed Ref.No. on the PCB, and they have become four digits after the header by adding "0" in the parts list.

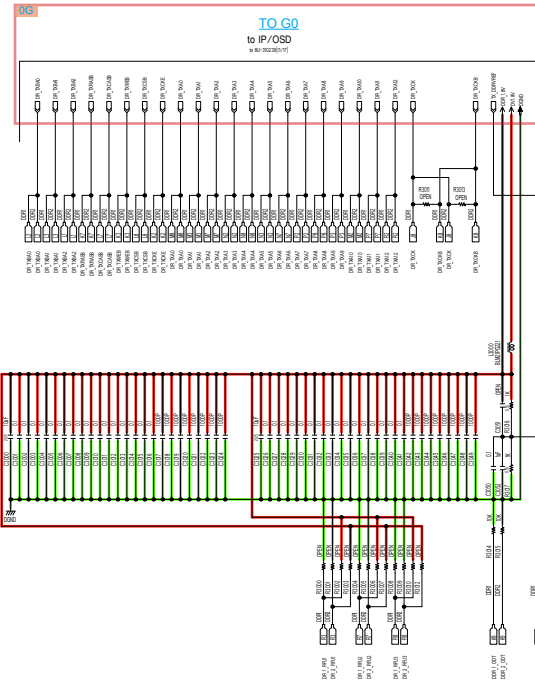
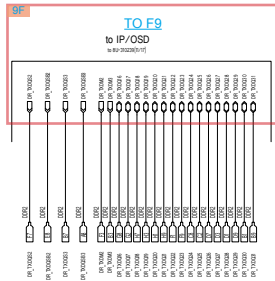
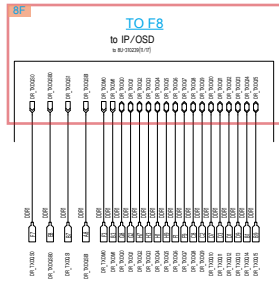

	1	2	3	4	5	6	7	8	9
A	DR_T801	DR_T802	DR_T803	DR_T804	DR_T805	DR_T806	DR_T807	DR_T808	DR_T809
B	DR_T810	DR_T811	DR_T812	DR_T813	DR_T814	DR_T815	DR_T816	DR_T817	DR_T818
C	DR_T819	DR_T820	DR_T821	DR_T822	DR_T823	DR_T824	DR_T825	DR_T826	DR_T827
D	DR_T828	DR_T829	DR_T830	DR_T831	DR_T832	DR_T833	DR_T834	DR_T835	DR_T836
E	DR_T837	DR_T838	DR_T839	DR_T840	DR_T841	DR_T842	DR_T843	DR_T844	DR_T845
F	DR_T846	DR_T847	DR_T848	DR_T849	DR_T850	DR_T851	DR_T852	DR_T853	DR_T854
G	DR_T855	DR_T856	DR_T857	DR_T858	DR_T859	DR_T860	DR_T861	DR_T862	DR_T863
H	DR_T864	DR_T865	DR_T866	DR_T867	DR_T868	DR_T869	DR_T870	DR_T871	DR_T872
J	DR_T873	DR_T874	DR_T875	DR_T876	DR_T877	DR_T878	DR_T879	DR_T880	DR_T881
K	DR_T882	DR_T883	DR_T884	DR_T885	DR_T886	DR_T887	DR_T888	DR_T889	DR_T890
L	DR_T891	DR_T892	DR_T893	DR_T894	DR_T895	DR_T896	DR_T897	DR_T898	DR_T899
M	DR_T900	DR_T901	DR_T902	DR_T903	DR_T904	DR_T905	DR_T906	DR_T907	DR_T908
N	DR_T909	DR_T910	DR_T911	DR_T912	DR_T913	DR_T914	DR_T915	DR_T916	DR_T917
P	DR_T918	DR_T919	DR_T920	DR_T921	DR_T922	DR_T923	DR_T924	DR_T925	DR_T926
R	DR_T927	DR_T928	DR_T929	DR_T930	DR_T931	DR_T932	DR_T933	DR_T934	DR_T935

U3000
A3R12E40DBF-8E
IP/OSD 1st DDR

	1	2	3	4	5	6	7	8	9
A	DR_T936	DR_T937	DR_T938	DR_T939	DR_T940	DR_T941	DR_T942	DR_T943	DR_T944
B	DR_T945	DR_T946	DR_T947	DR_T948	DR_T949	DR_T950	DR_T951	DR_T952	DR_T953
C	DR_T954	DR_T955	DR_T956	DR_T957	DR_T958	DR_T959	DR_T960	DR_T961	DR_T962
D	DR_T963	DR_T964	DR_T965	DR_T966	DR_T967	DR_T968	DR_T969	DR_T970	DR_T971
E	DR_T972	DR_T973	DR_T974	DR_T975	DR_T976	DR_T977	DR_T978	DR_T979	DR_T980
F	DR_T981	DR_T982	DR_T983	DR_T984	DR_T985	DR_T986	DR_T987	DR_T988	DR_T989
G	DR_T990	DR_T991	DR_T992	DR_T993	DR_T994	DR_T995	DR_T996	DR_T997	DR_T998
H	DR_T999	DR_T1000	DR_T1001	DR_T1002	DR_T1003	DR_T1004	DR_T1005	DR_T1006	DR_T1007
J	DR_T1008	DR_T1009	DR_T1010	DR_T1011	DR_T1012	DR_T1013	DR_T1014	DR_T1015	DR_T1016
K	DR_T1017	DR_T1018	DR_T1019	DR_T1020	DR_T1021	DR_T1022	DR_T1023	DR_T1024	DR_T1025
L	DR_T1026	DR_T1027	DR_T1028	DR_T1029	DR_T1030	DR_T1031	DR_T1032	DR_T1033	DR_T1034
M	DR_T1035	DR_T1036	DR_T1037	DR_T1038	DR_T1039	DR_T1040	DR_T1041	DR_T1042	DR_T1043
N	DR_T1044	DR_T1045	DR_T1046	DR_T1047	DR_T1048	DR_T1049	DR_T1050	DR_T1051	DR_T1052
P	DR_T1053	DR_T1054	DR_T1055	DR_T1056	DR_T1057	DR_T1058	DR_T1059	DR_T1060	DR_T1061
R	DR_T1062	DR_T1063	DR_T1064	DR_T1065	DR_T1066	DR_T1067	DR_T1068	DR_T1069	DR_T1070

U3001
A3R12E40DBF-8E
IP/OSD 2nd DDR

- GND LINE
- POWER+ LINE
- POWER- LINE
- AUDIO SIGNAL
- TMDS SIGNAL
- ANALOG VIDEO
- DIGITAL VIDEO

IP/OSD DDR
 8U-310239(12/17)
 DIGITAL_UNIT

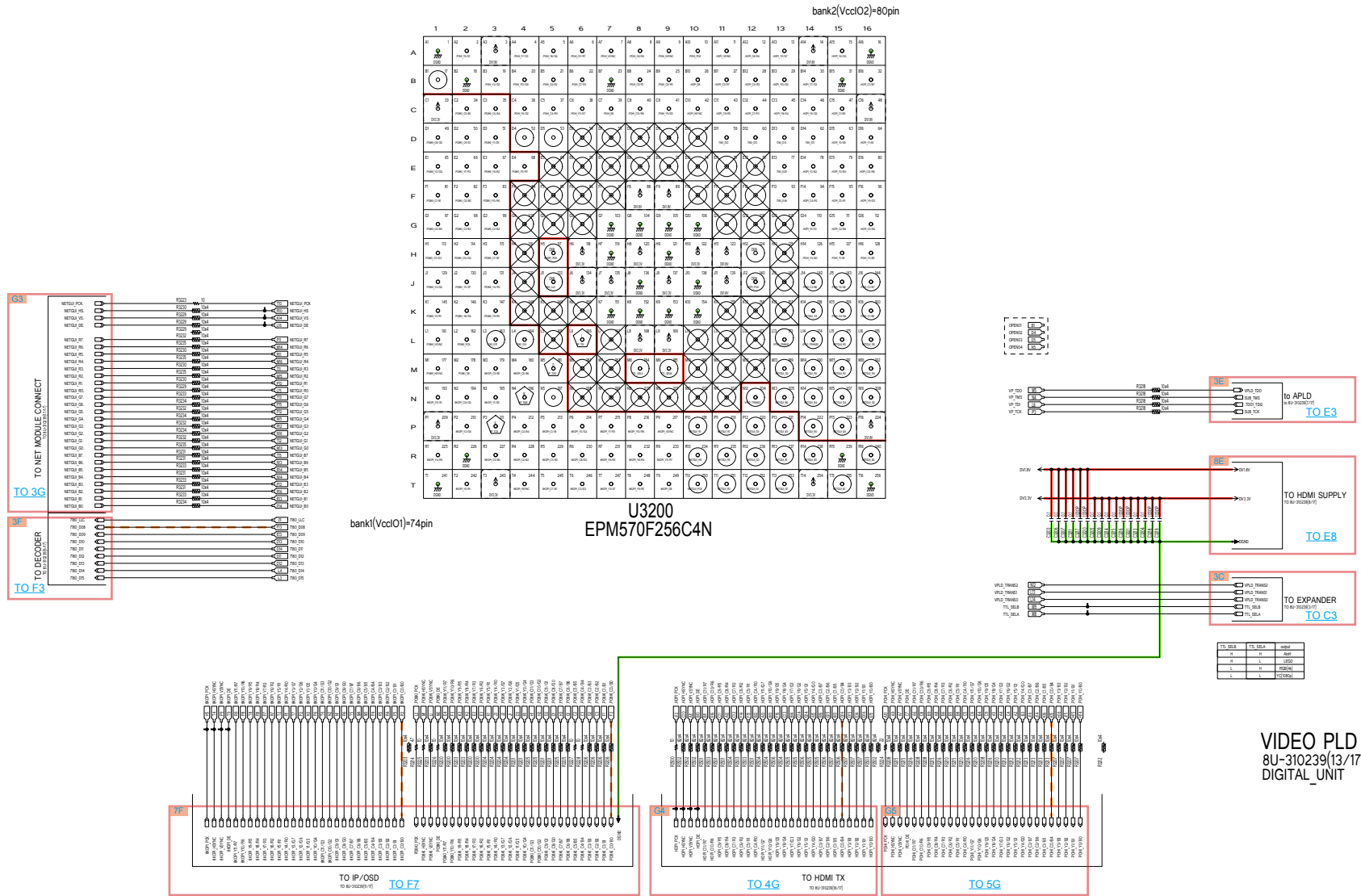

SCH14 DIG HDMI SW2 Rx(MN64788)

All Ref.No. has been described in the parts list are four digits.
But there are less than four digits of printed Ref.No. on the PCB, and they have become four digits after the header by adding "0" in the parts list.

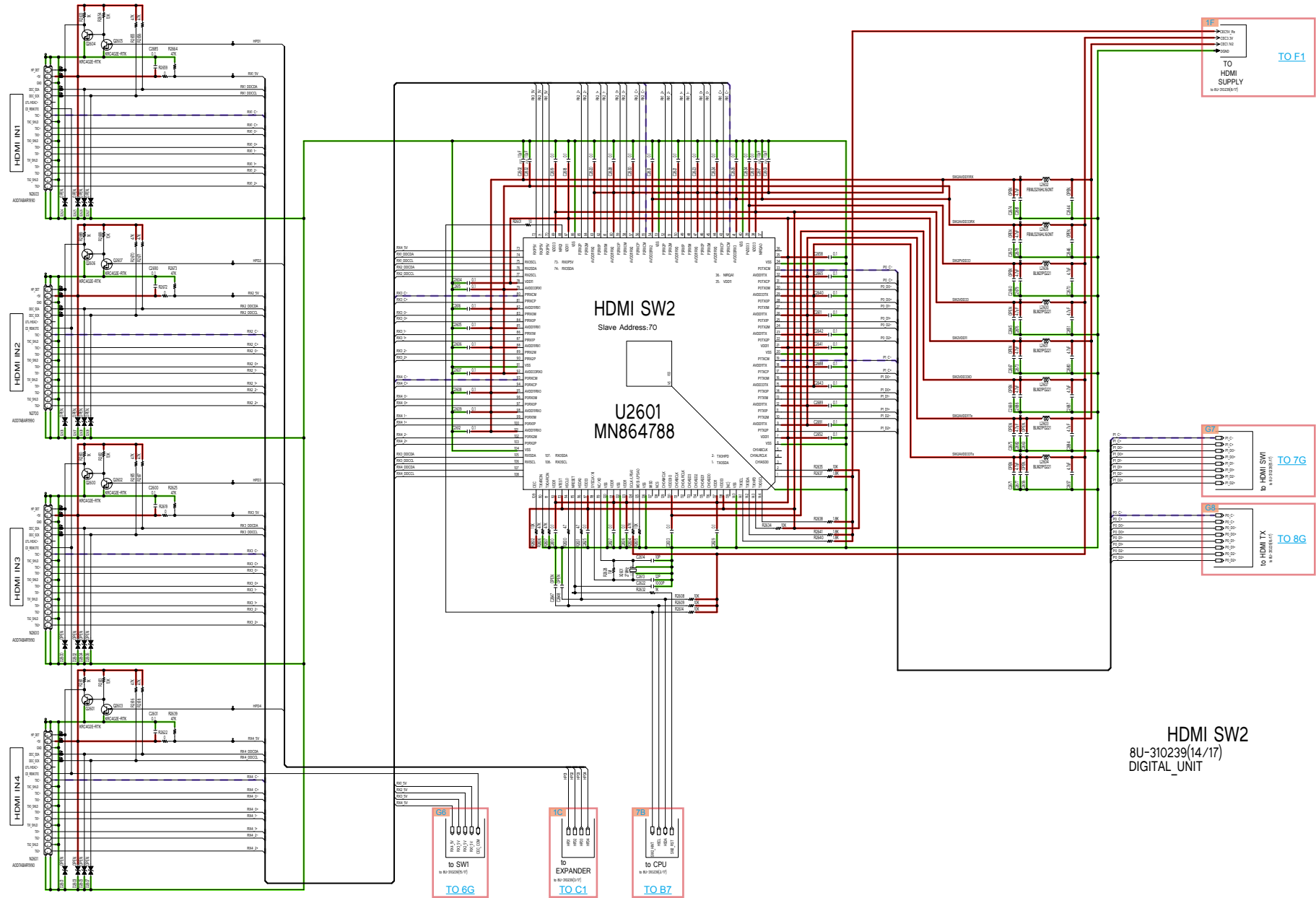

GND LINE POWER+ LINE POWER- LINE AUDIO SIGNAL TMDS SIGNAL ANALOG VIDEO DIGITAL VIDEO

Before Servicing
This Unit

Electrical

Mechanical

Repair Information

Updating

SCH15 DIG HDMI SW1 Rx & Z2out(MN864788)

All Ref.No. has been described in the parts list are four digits.
But there are less than four digits of printed Ref.No. on the PCB, and they have become four digits after the header by adding "0" in the parts list.

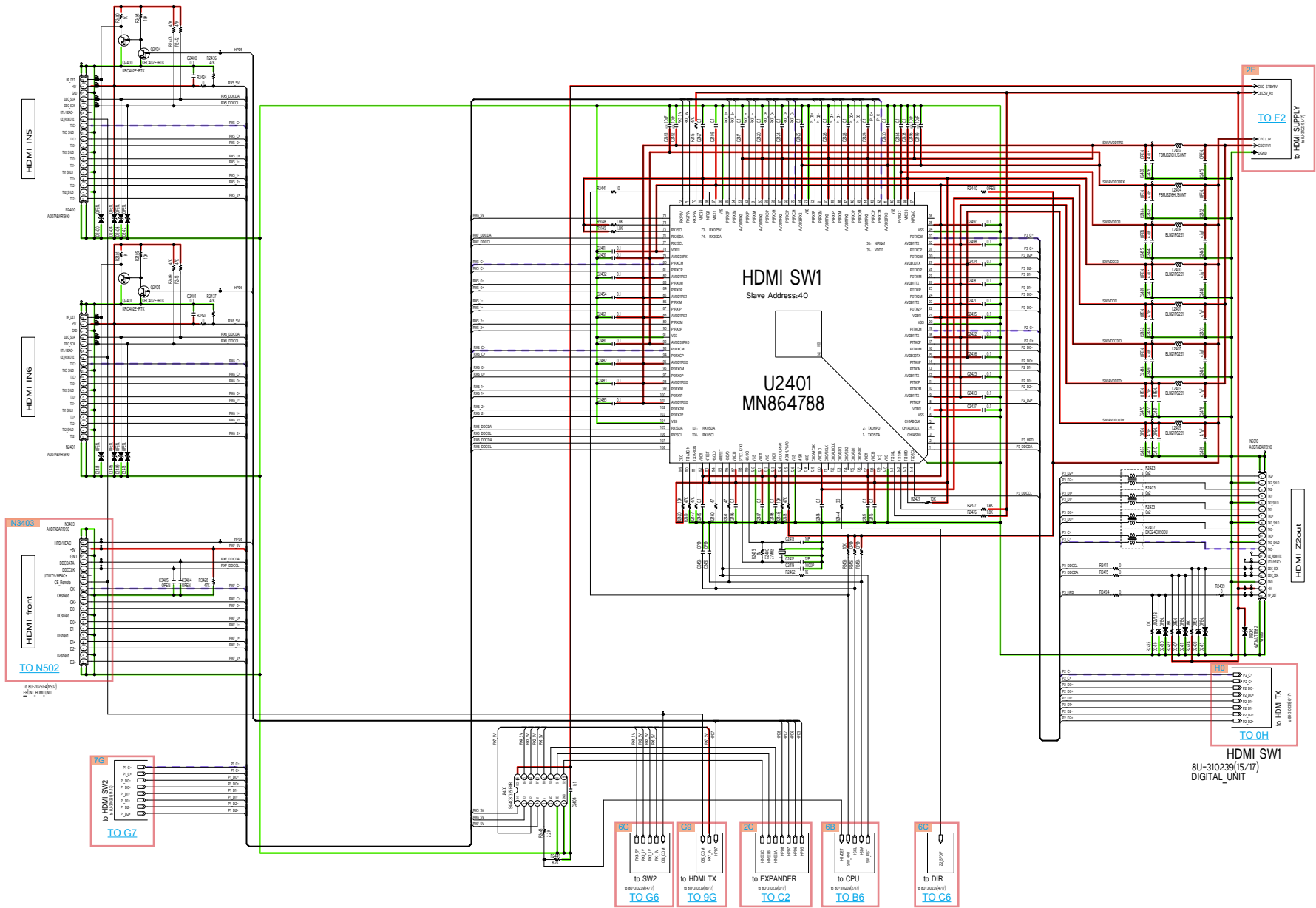

GND LINE POWER+ LINE POWER- LINE AUDIO SIGNAL TMDS SIGNAL ANALOG VIDEO DIGITAL VIDEO

SCH16 DIG HDMI TX(MN864807)

All Ref.No. has been described in the parts list are four digits.
But there are less than four digits of printed Ref.No. on the PCB, and they have become four digits after the header by adding "0" in the parts list.

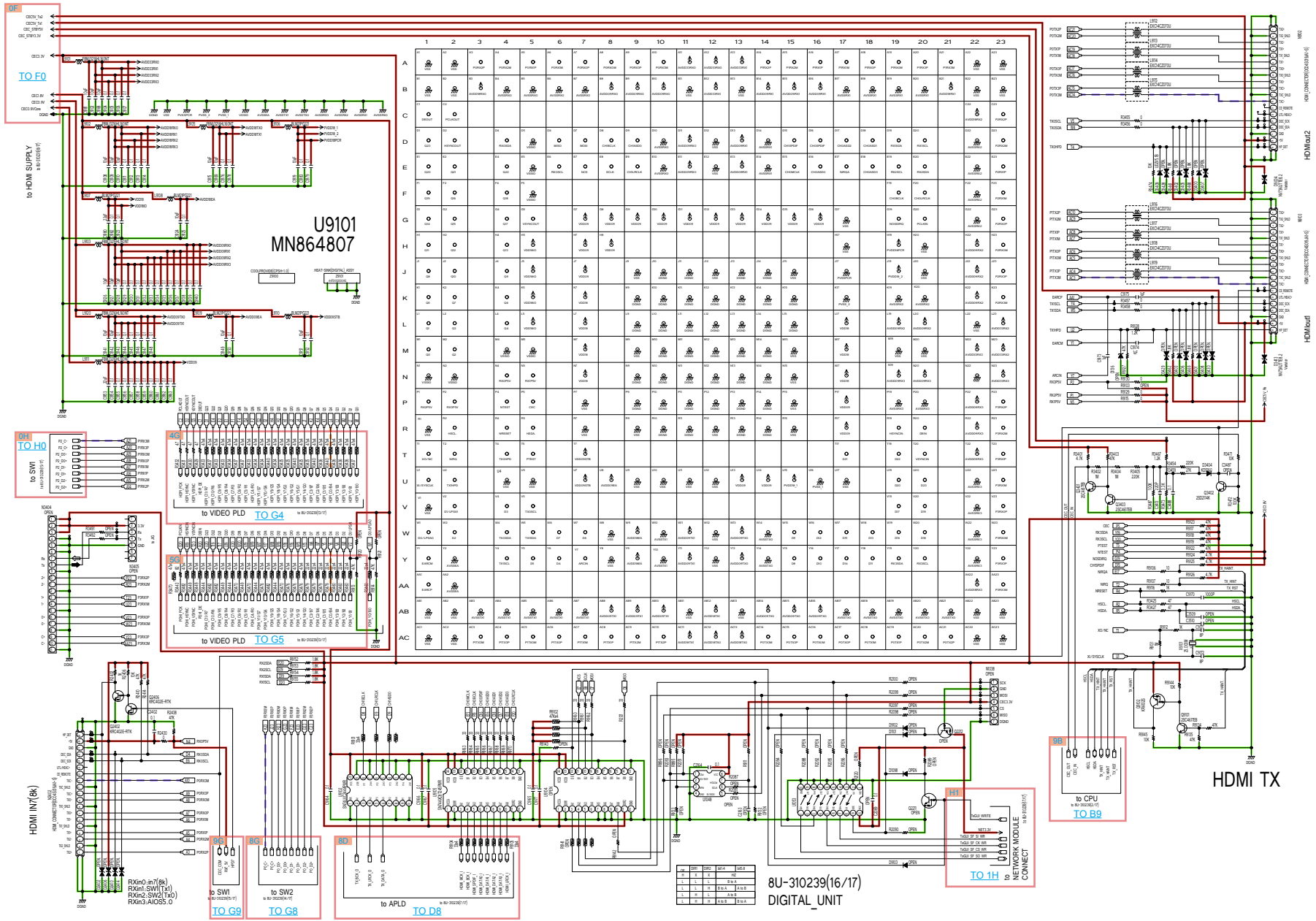

GND LINE POWER+ LINE POWER- LINE AUDIO SIGNAL TMDS SIGNAL ANALOG VIDEO DIGITAL VIDEO

Before Servicing This Unit
 Electrical
 Mechanical
 Repair Information
 Updating

SCH17 DIG NET MODULE CONNECT

All Ref.No. has been described in the parts list are four digits.
But there are less than four digits of printed Ref.No. on the PCB, and they have become four digits after the header by adding "0" in the parts list.

Before Servicing
This Unit

Electrical

Mechanical

Repair Information

Updating

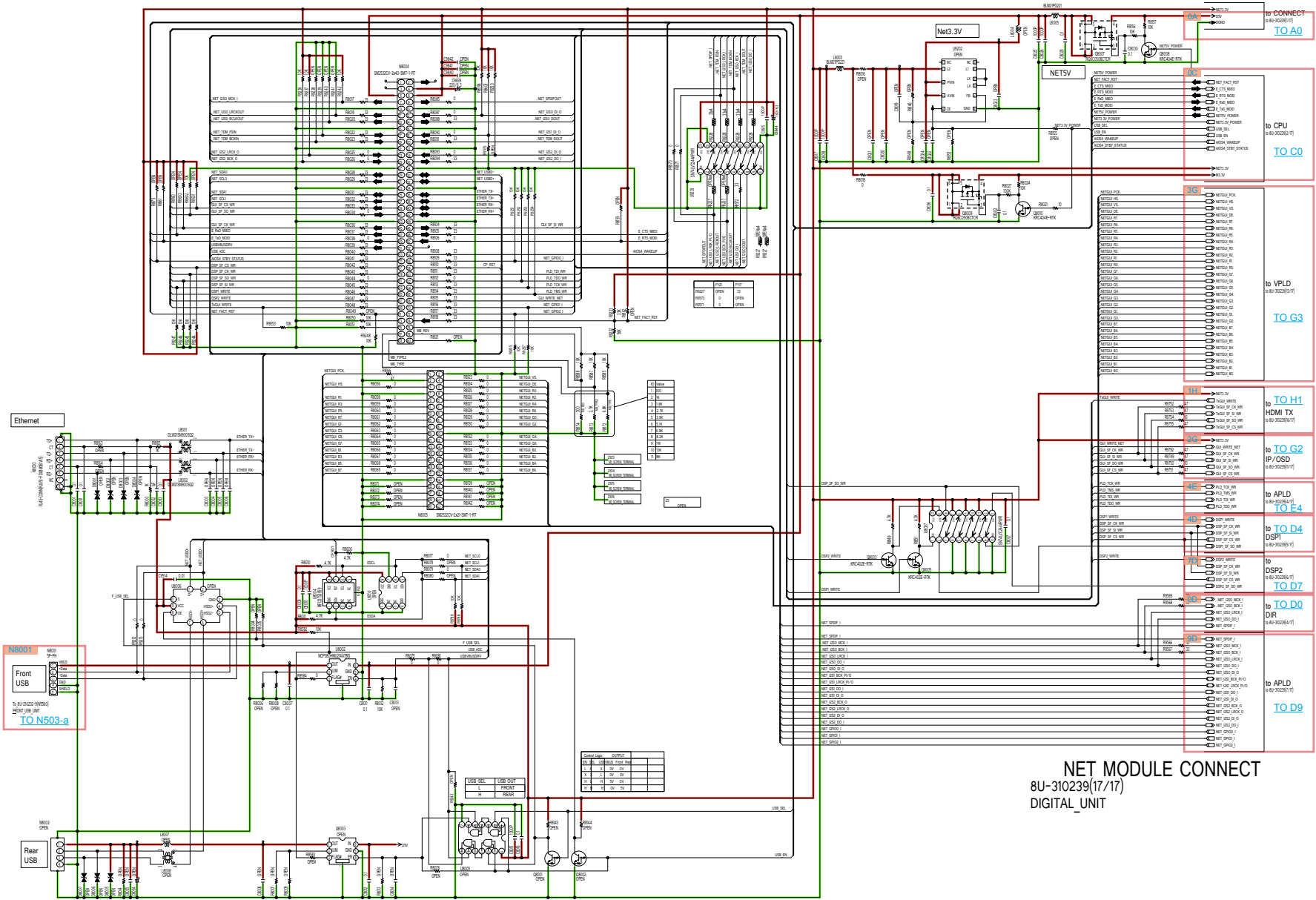

NET MODULE CONNECT
8U-310239(17/17)
DIGITAL_UNIT

GND LINE POWER+ LINE POWER- LINE AUDIO SIGNAL TMDS SIGNAL ANALOG VIDEO DIGITAL VIDEO

SCH18 SPK SIDE CONNECT

All Ref.No. has been described in the parts list are four digits.
But there are less than four digits of printed Ref.No. on the PCB, and they have become four digits after the header by adding "0" in the parts list.

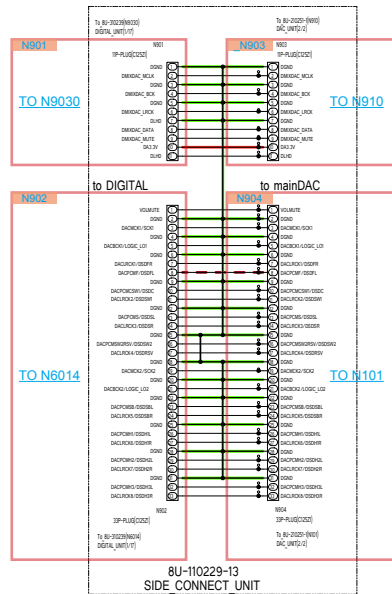

SIDE_CONNECT

GND LINE POWER+ LINE POWER- LINE AUDIO SIGNAL TMDS SIGNAL ANALOG VIDEO DIGITAL VIDEO

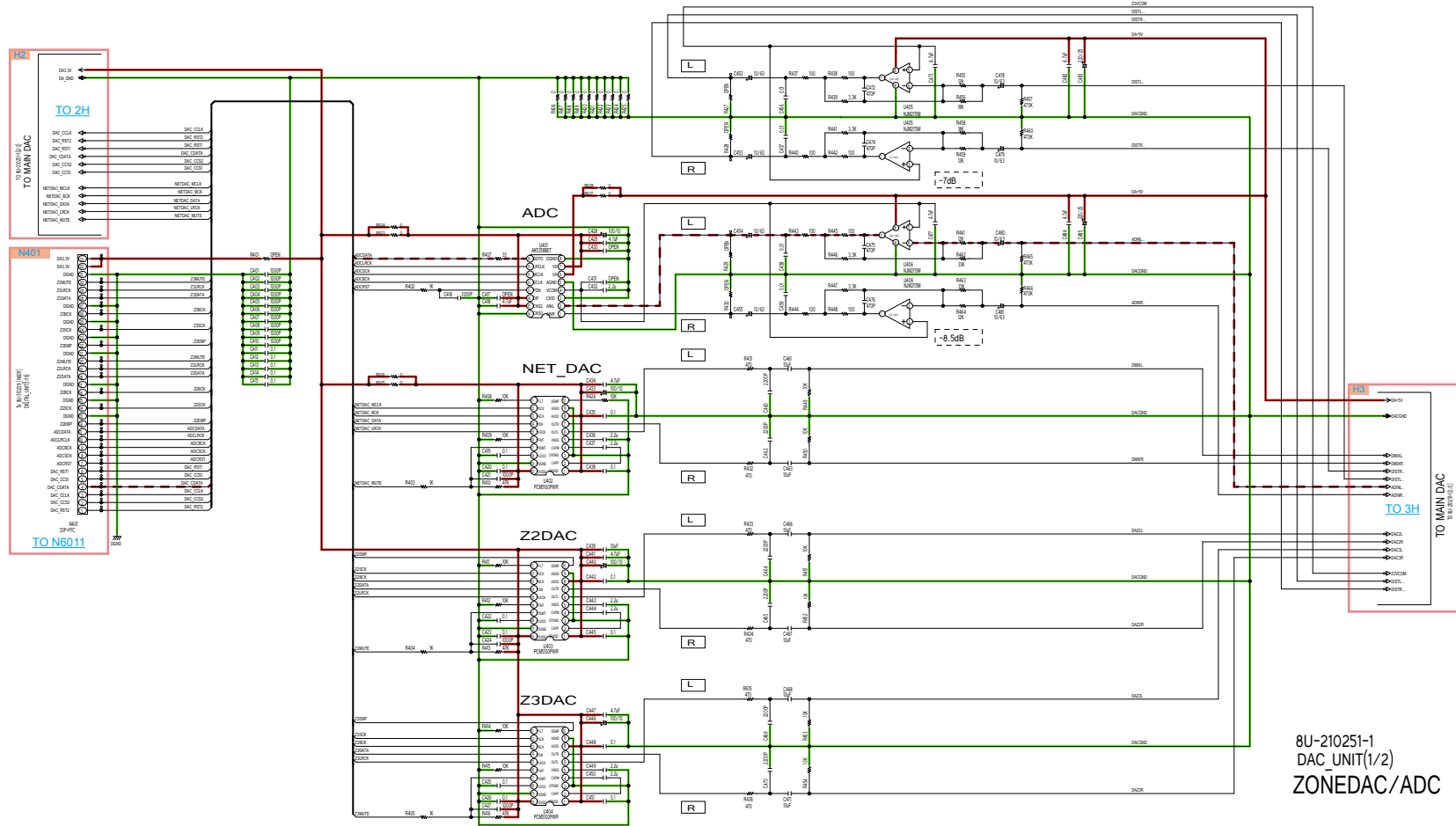

8U-210251-1
 DAC_UNIT(1/2)
 ZONEDAC/ADC

- GND LINE
- POWER+ LINE
- POWER- LINE
- AUDIO SIGNAL
- TMDS SIGNAL
- ANALOG VIDEO
- DIGITAL VIDEO

SCH20 DAC 13ch MainDAC

All Ref.No. has been described in the parts list are four digits.
But there are less than four digits of printed Ref.No. on the PCB, and they have become four digits after the header by adding "0" in the parts list.

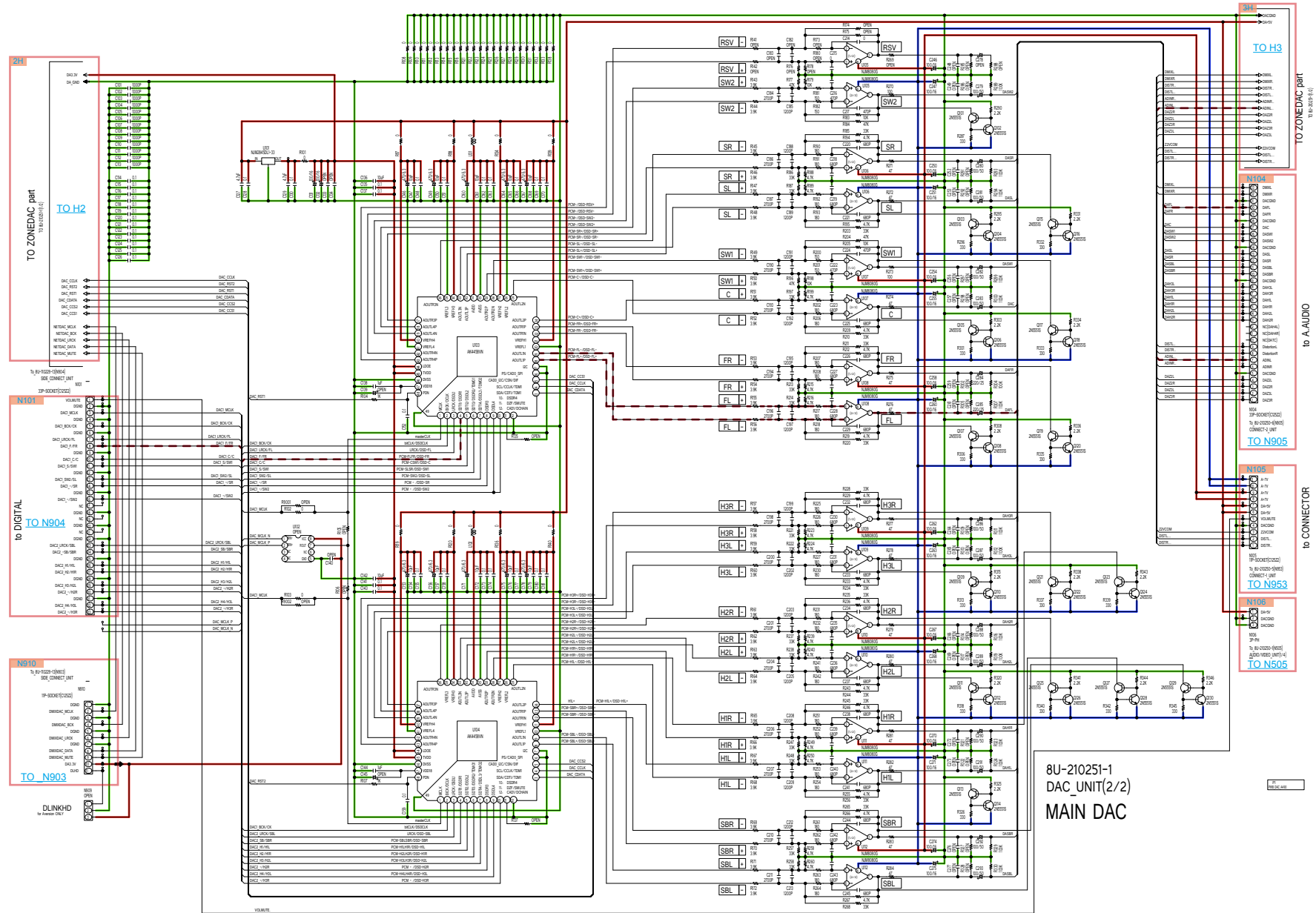

GND LINE POWER+ LINE POWER- LINE AUDIO SIGNAL TMDS SIGNAL ANALOG VIDEO DIGITAL VIDEO

SCH21 AV REAR INPUT

All Ref.No. has been described in the parts list are four digits.
 But there are less than four digits of printed Ref.No. on the PCB, and they have become four digits after the header by adding "0" in the parts list.

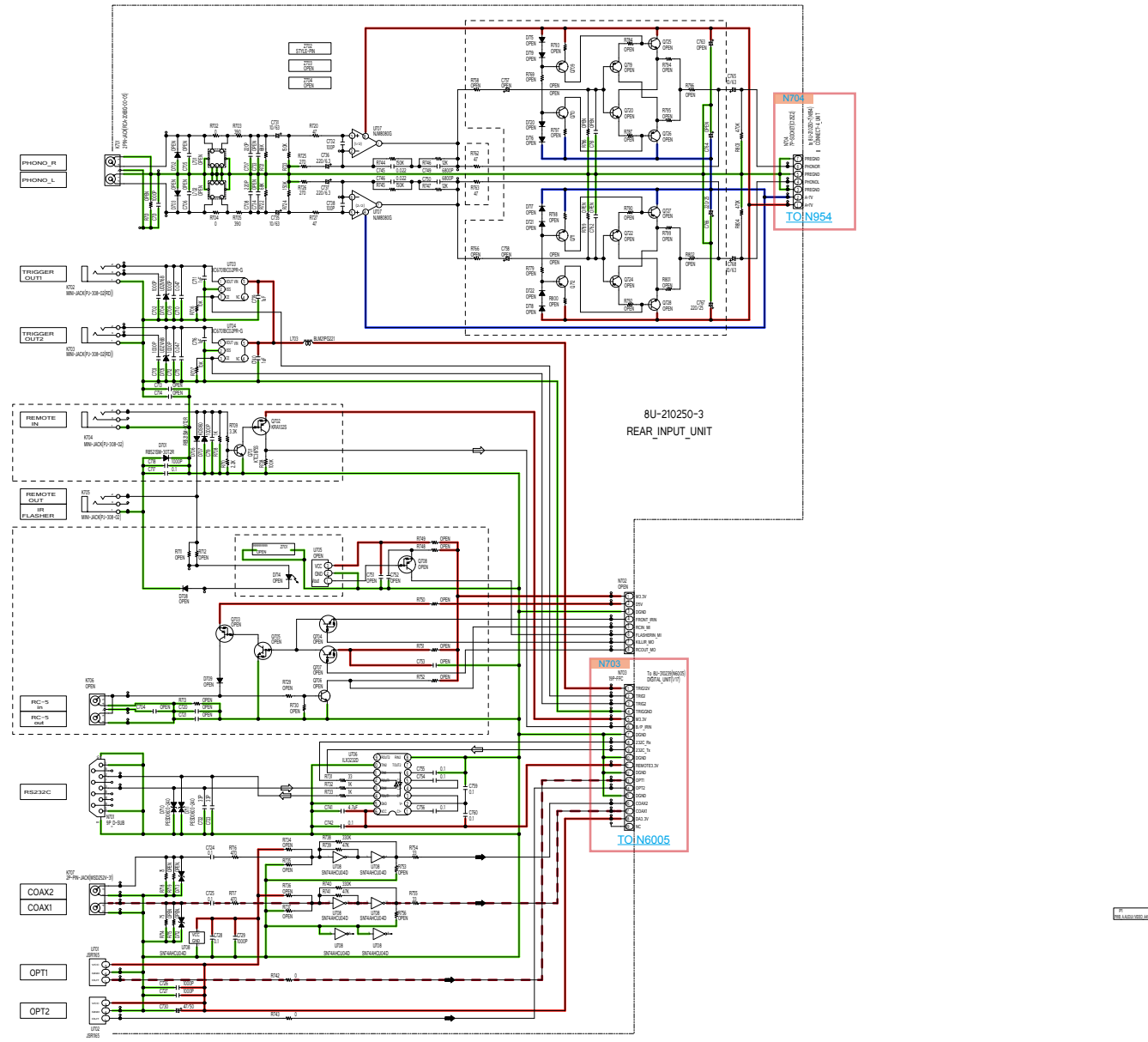

8U-210250-3
 PHONO/232C UNIT

GND LINE POWER+ LINE POWER- LINE AUDIO SIGNAL TMDS SIGNAL ANALOG VIDEO DIGITAL VIDEO

SCH22 AV CONNECT

All Ref.No. has been described in the parts list are four digits.
But there are less than four digits of printed Ref.No. on the PCB, and they have become four digits after the header by adding "0" in the parts list.

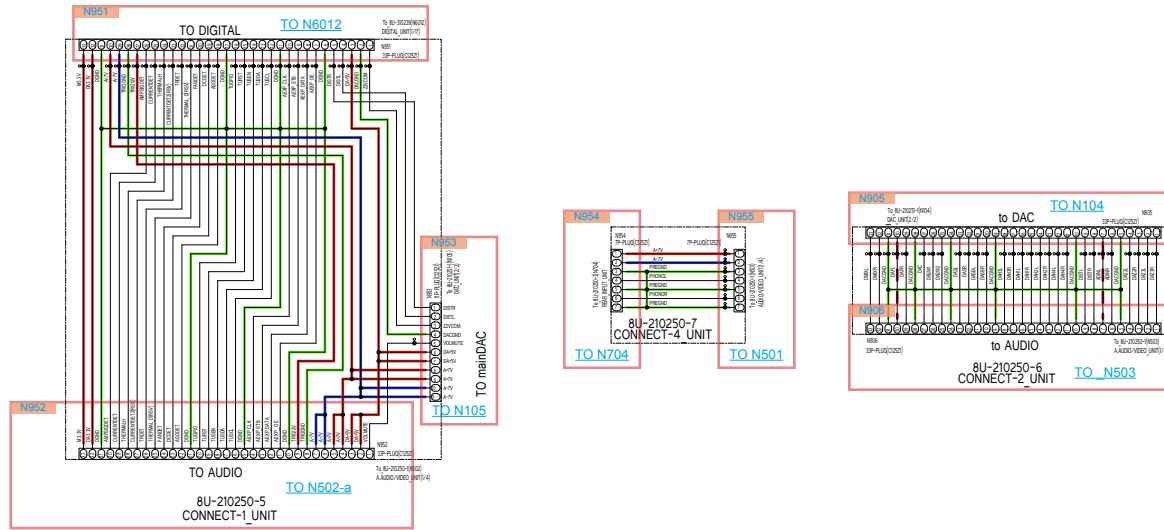

CONNECT

- GND LINE
- POWER+ LINE
- POWER- LINE
- AUDIO SIGNAL
- TMDS SIGNAL
- ANALOG VIDEO
- DIGITAL VIDEO

SCH23 AV AUDIO VIDEO CONNECT

All Ref.No. has been described in the parts list are four digits.
But there are less than four digits of printed Ref.No. on the PCB, and they have become four digits after the header by adding "0" in the parts list.

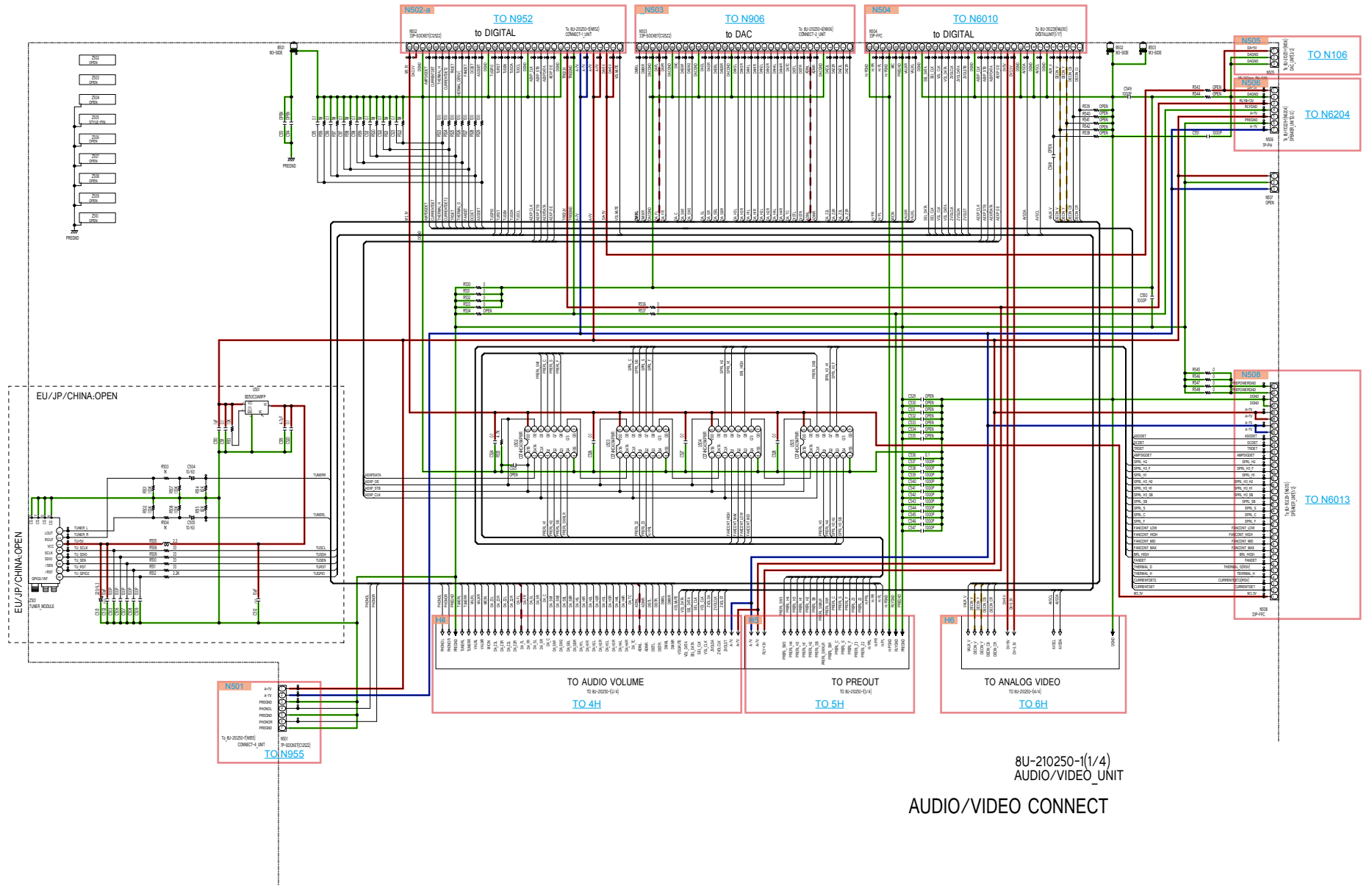

8U-210250-1(1/4)
AUDIO/VIDEO_UNIT

AUDIO/VIDEO CONNECT

- GND LINE
- POWER+ LINE
- POWER- LINE
- AUDIO SIGNAL
- TMDS SIGNAL
- ANALOG VIDEO
- DIGITAL VIDEO

SCH24 AV AUDIO VIDEO VOLUME

All Ref.No. has been described in the parts list are four digits.
 But there are less than four digits of printed Ref.No. on the PCB, and they have become four digits after the header by adding "0" in the parts list.

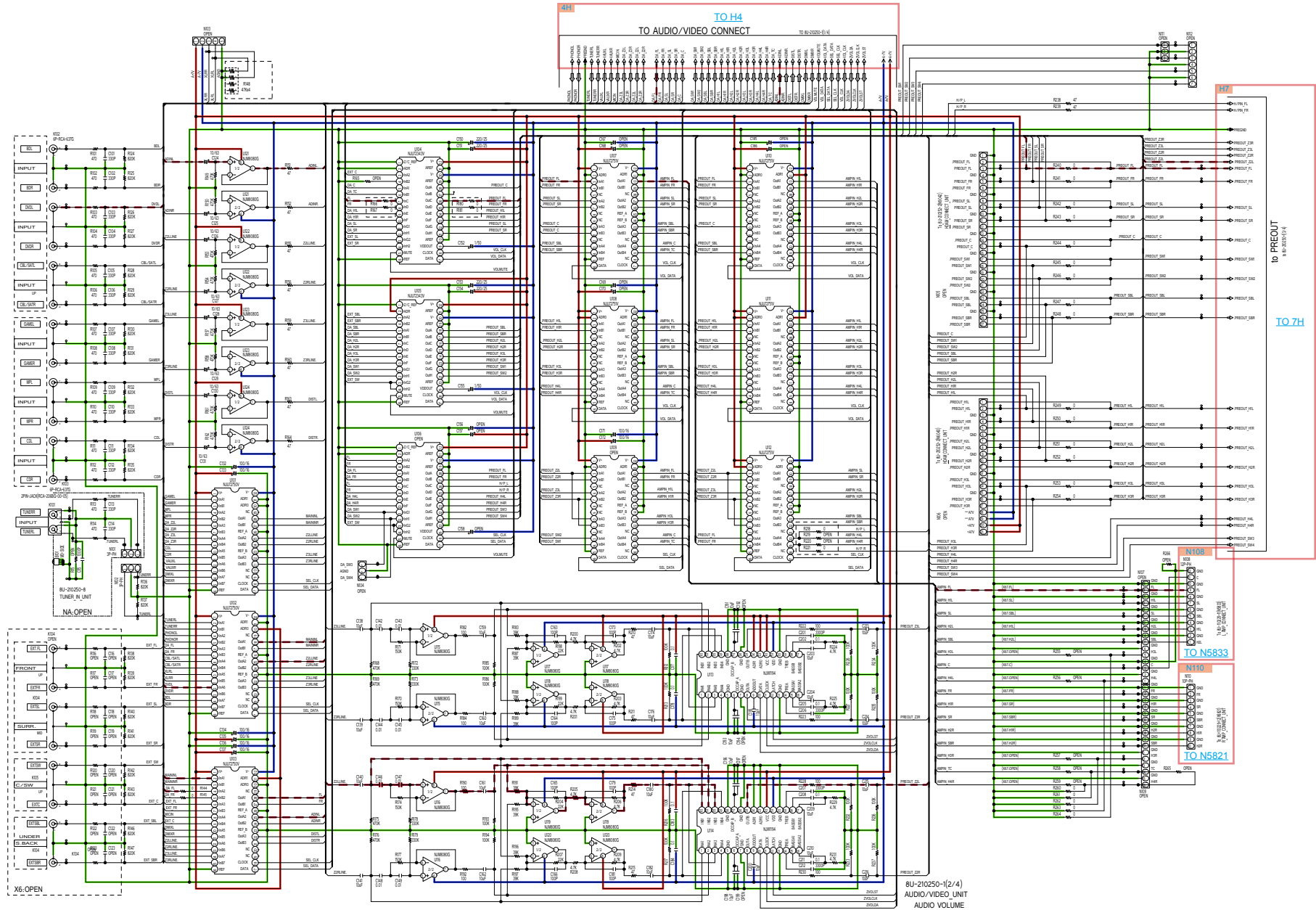

GND LINE POWER+ LINE POWER- LINE AUDIO SIGNAL TMDS SIGNAL ANALOG VIDEO DIGITAL VIDEO

Before Servicing This Unit

Electrical

Mechanical

Repair Information

Updating

SCH25 AV AUDIO VIDEO PREOUT

All Ref.No. has been described in the parts list are four digits.
 But there are less than four digits of printed Ref.No. on the PCB, and they have become four digits after the header by adding "0" in the parts list.

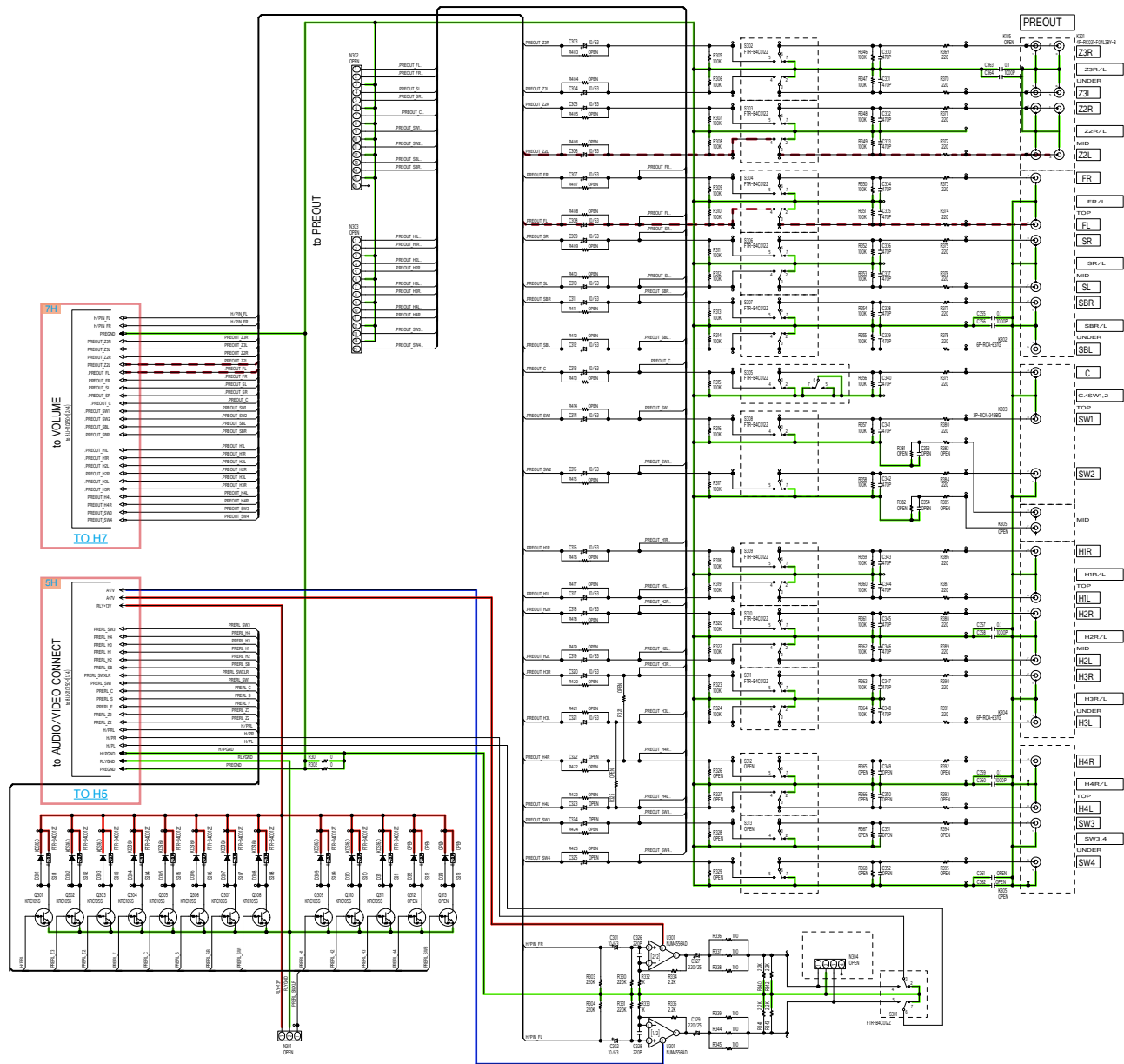

8U-210250-1(3/4)
 AUDIO/VIDEO UNIT
 PREOUT

- GND LINE
- POWER+ LINE
- POWER- LINE
- AUDIO SIGNAL
- TMDS SIGNAL
- ANALOG VIDEO
- DIGITAL VIDEO

Before Servicing This Unit
 Electrical
 Mechanical
 Repair Information
 Updating

SCH26 AV AUDIO VIDEO VIDEO

All Ref.No. has been described in the parts list are four digits.
But there are less than four digits of printed Ref.No. on the PCB, and they have become four digits after the header by adding "0" in the parts list.

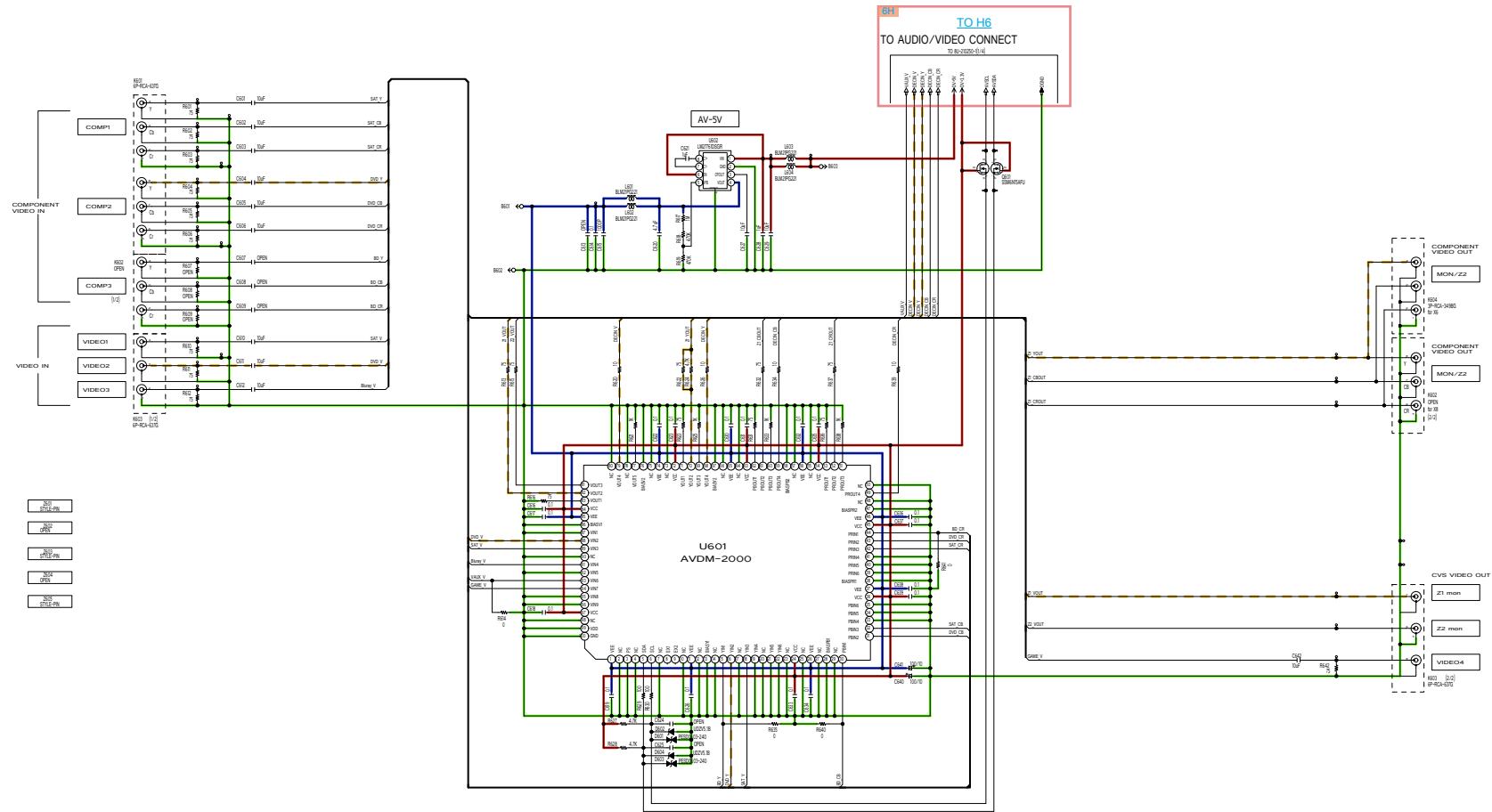

8U-210250-1(4/4)
AUDIO/VIDEO_UNIT
VIDEO_SELECTOR

GND LINE POWER+ LINE POWER- LINE AUDIO SIGNAL TMDS SIGNAL ANALOG VIDEO DIGITAL VIDEO

SCH27 P.AMP POWER AMP-1

All Ref.No. has been described in the parts list are four digits.
But there are less than four digits of printed Ref.No. on the PCB, and they have become four digits after the header by adding "0" in the parts list.

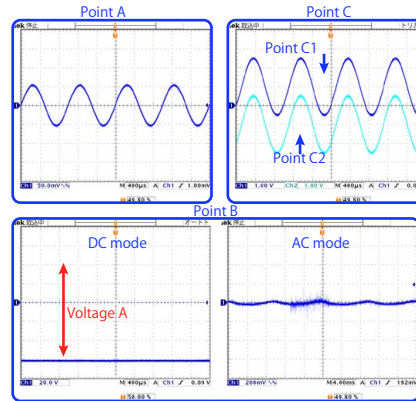
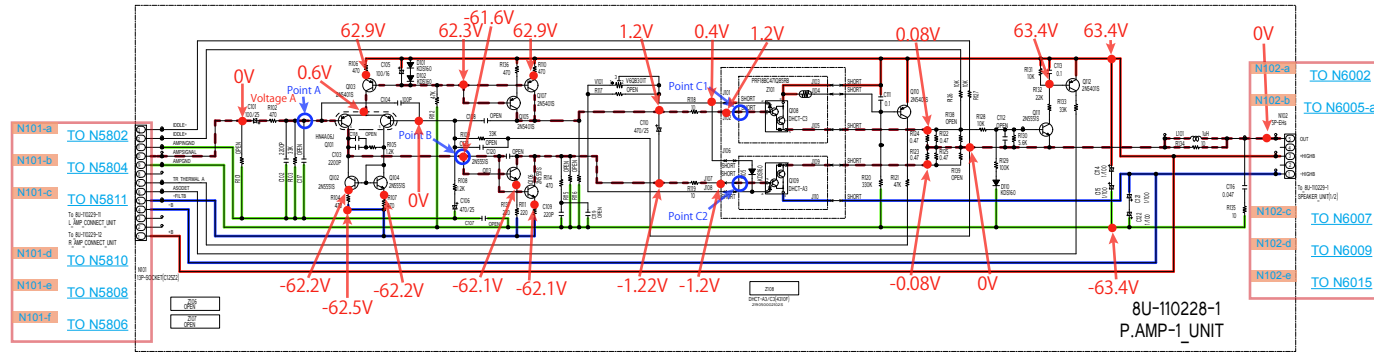

Measurement condition
 • Voltage measurement : No signal
 • Waveform measurement
 INPUT: 200mVrms / 1KHz (ANALOG)
 Surround mode: MCh Stereo
 VOL: 70
 Speaker load: 8ohms

POWER AMP

SCH28 P.AMP POWER AMP-2

All Ref.No. has been described in the parts list are four digits.
But there are less than four digits of printed Ref.No. on the PCB, and they have become four digits after the header by adding "0" in the parts list.

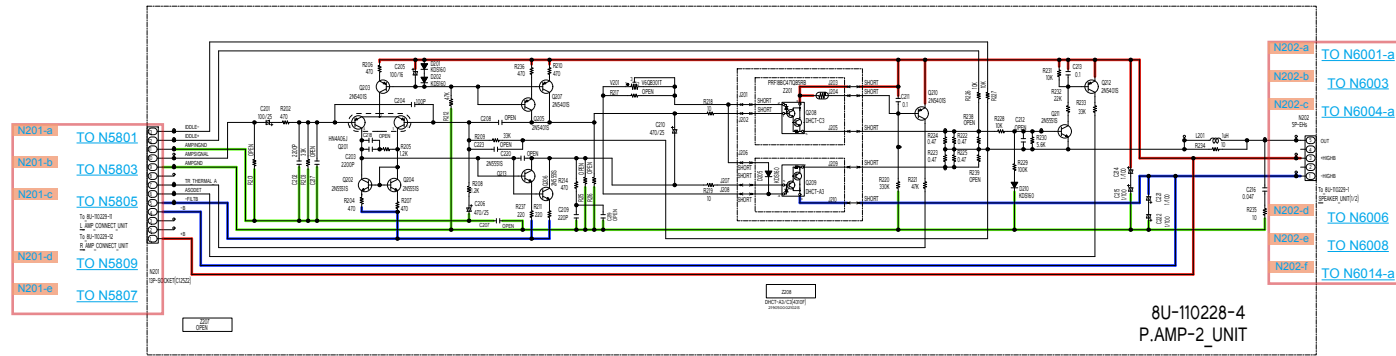

POWER AMP

GND LINE POWER+ LINE POWER- LINE AUDIO SIGNAL TMDS SIGNAL ANALOG VIDEO DIGITAL VIDEO

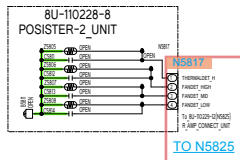
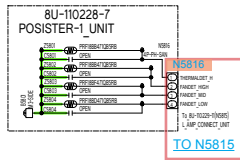

11
N5818 AMP

SCH30 SPK AMP CONNECT

All Ref.No. has been described in the parts list are four digits.
But there are less than four digits of printed Ref.No. on the PCB, and they have become four digits after the header by adding "0" in the parts list.

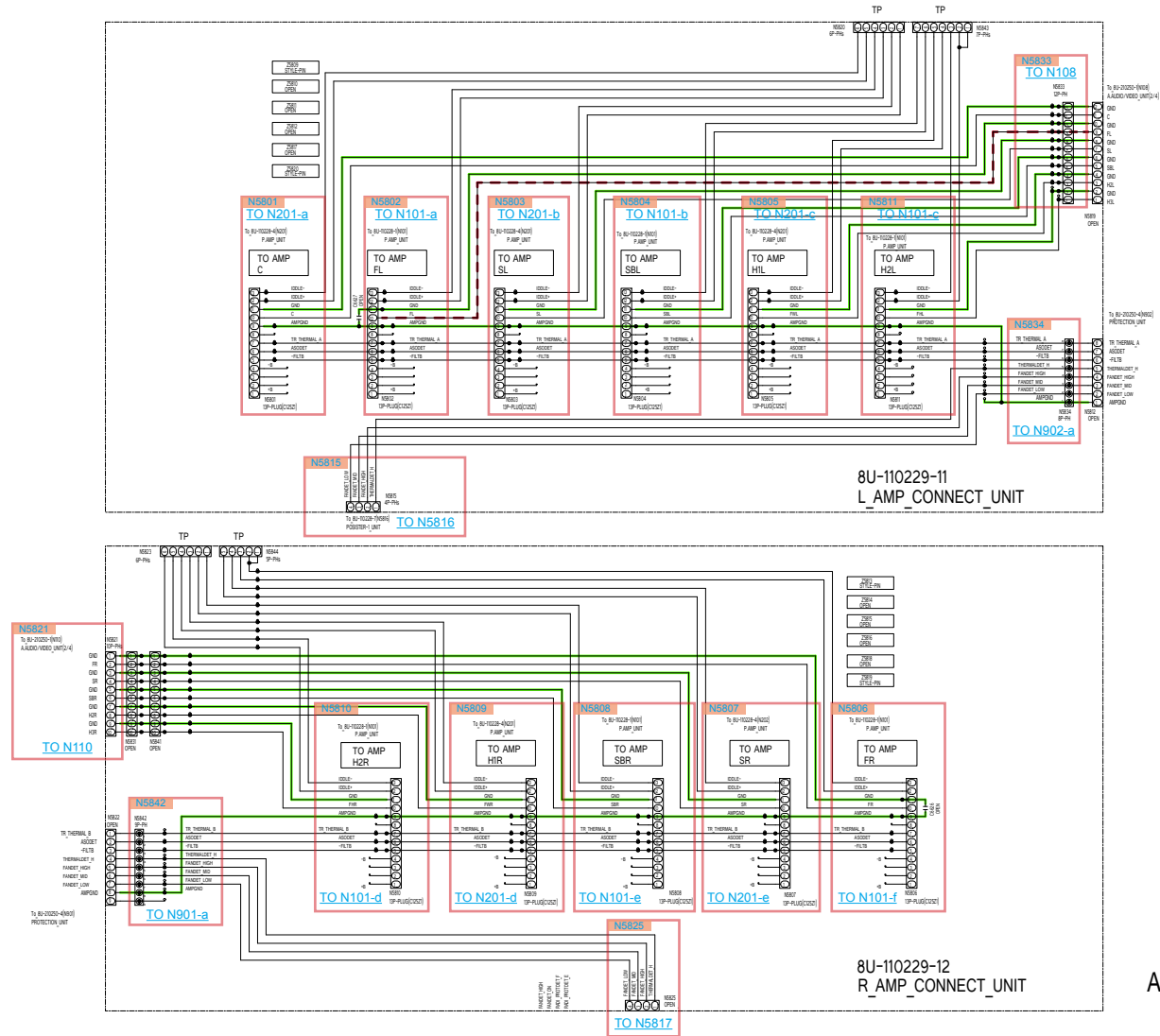

AMP CONNECT

- GND LINE
- POWER+ LINE
- POWER- LINE
- AUDIO SIGNAL
- TMDS SIGNAL
- ANALOG VIDEO
- DIGITAL VIDEO

SCH31 SPK SPEAKER(1-2)

All Ref.No. has been described in the parts list are four digits.
 But there are less than four digits of printed Ref.No. on the PCB, and they have become four digits after the header by adding "0" in the parts list.

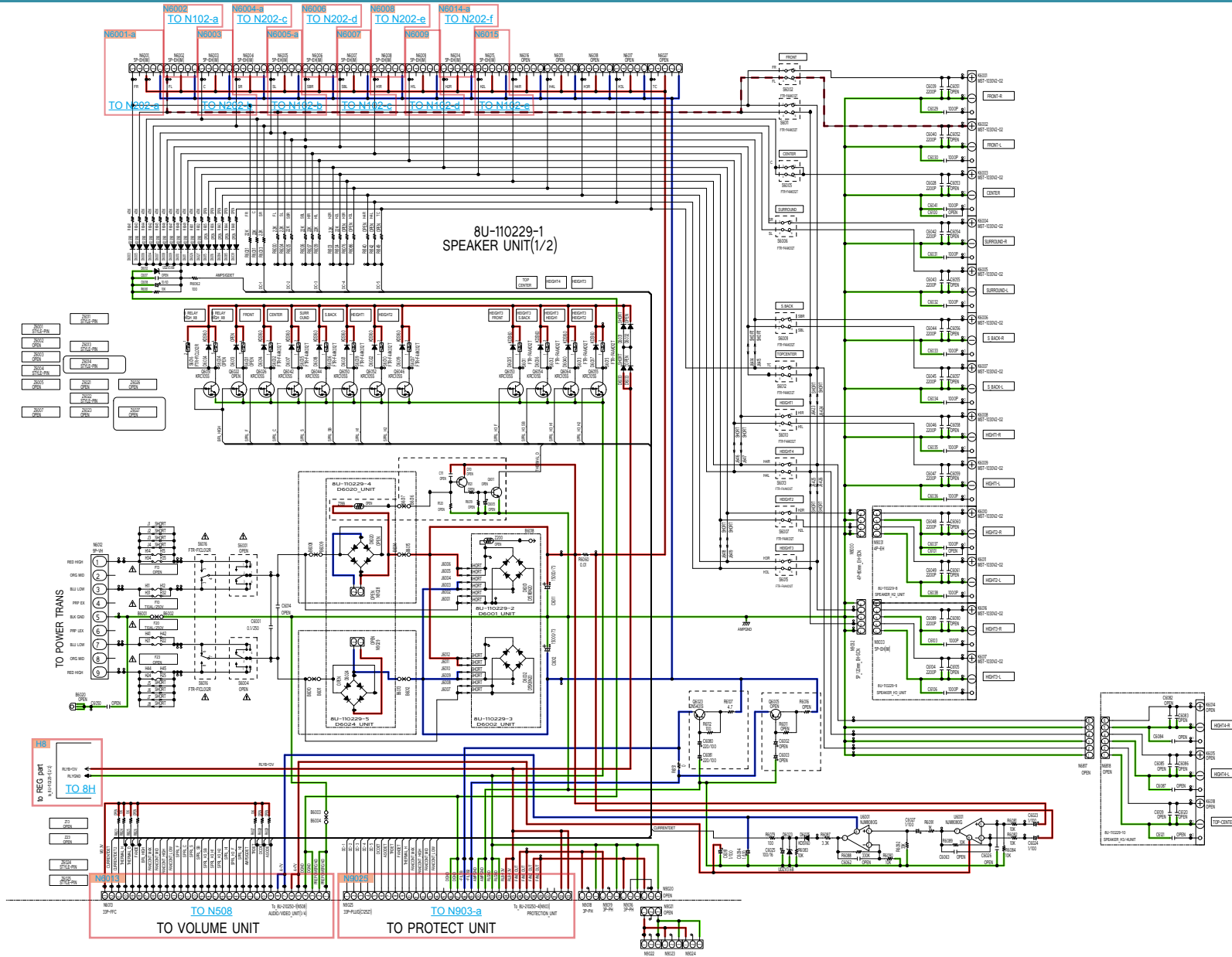

GND LINE POWER+ LINE POWER- LINE AUDIO SIGNAL TMDS SIGNAL ANALOG VIDEO DIGITAL VIDEO

Before Servicing
This Unit

Electrical

Mechanical

Repair Information

Updating

SCH32 SPK SPEAKER(2-2)

All Ref.No. has been described in the parts list are four digits.
But there are less than four digits of printed Ref.No. on the PCB, and they have become four digits after the header by adding "0" in the parts list.

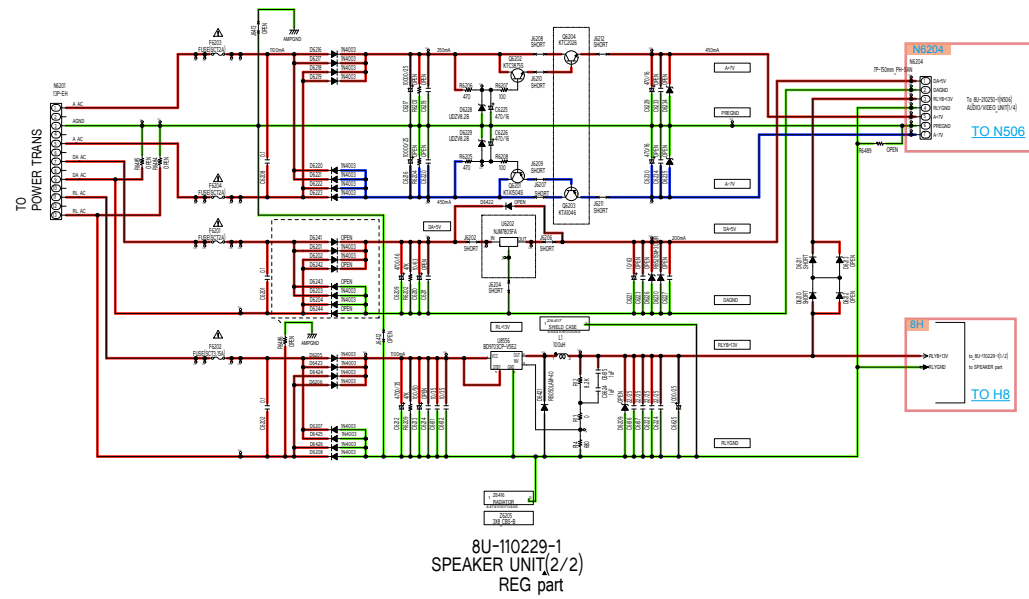

— GND LINE
 — POWER+ LINE
 — POWER- LINE
 — AUDIO SIGNAL
 — TMDS SIGNAL
 — ANALOG VIDEO
 — DIGITAL VIDEO

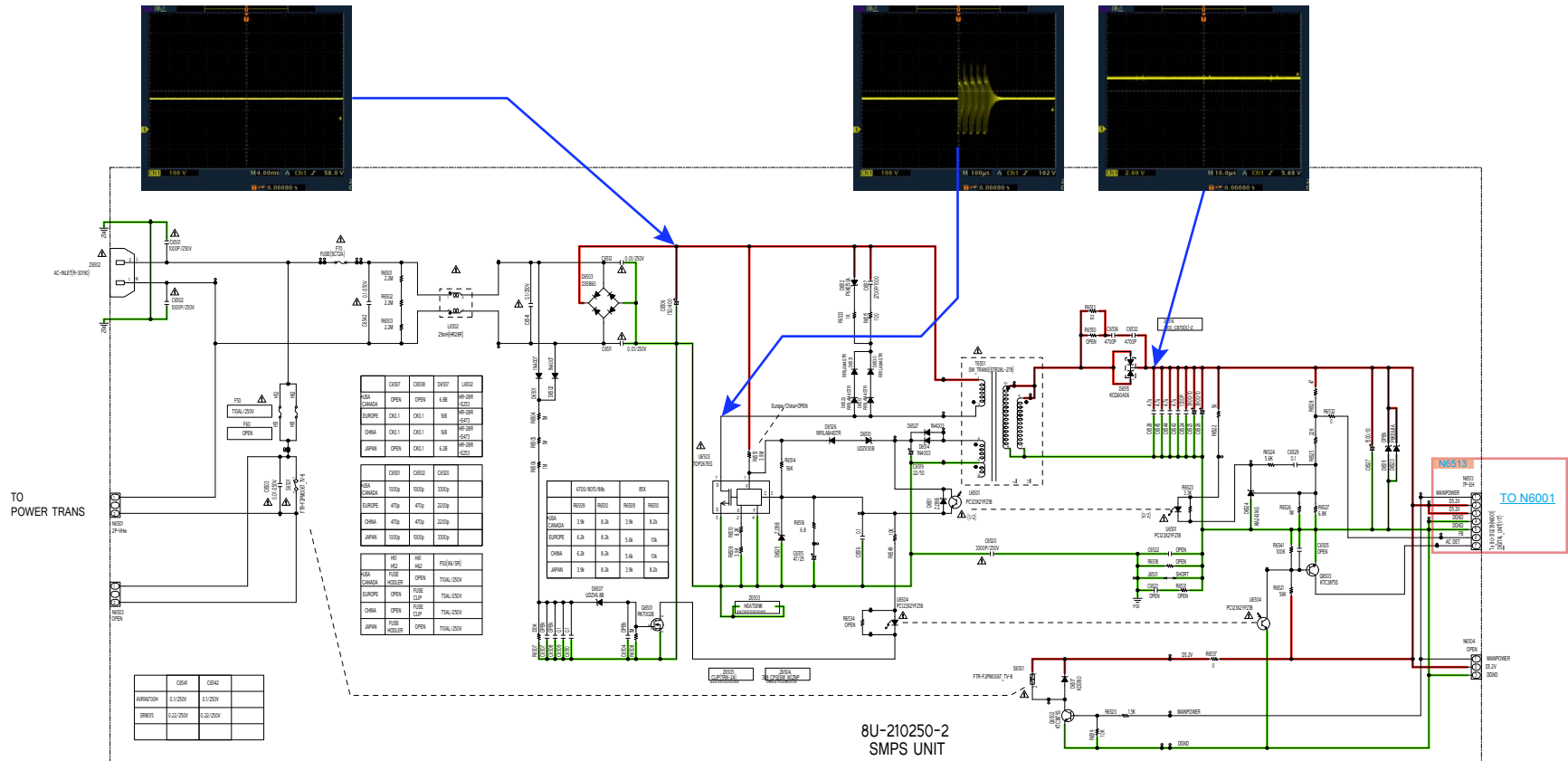

SMPS

- GND LINE
- POWER+ LINE
- POWER- LINE
- AUDIO SIGNAL
- TMDS SIGNAL
- ANALOG VIDEO
- DIGITAL VIDEO

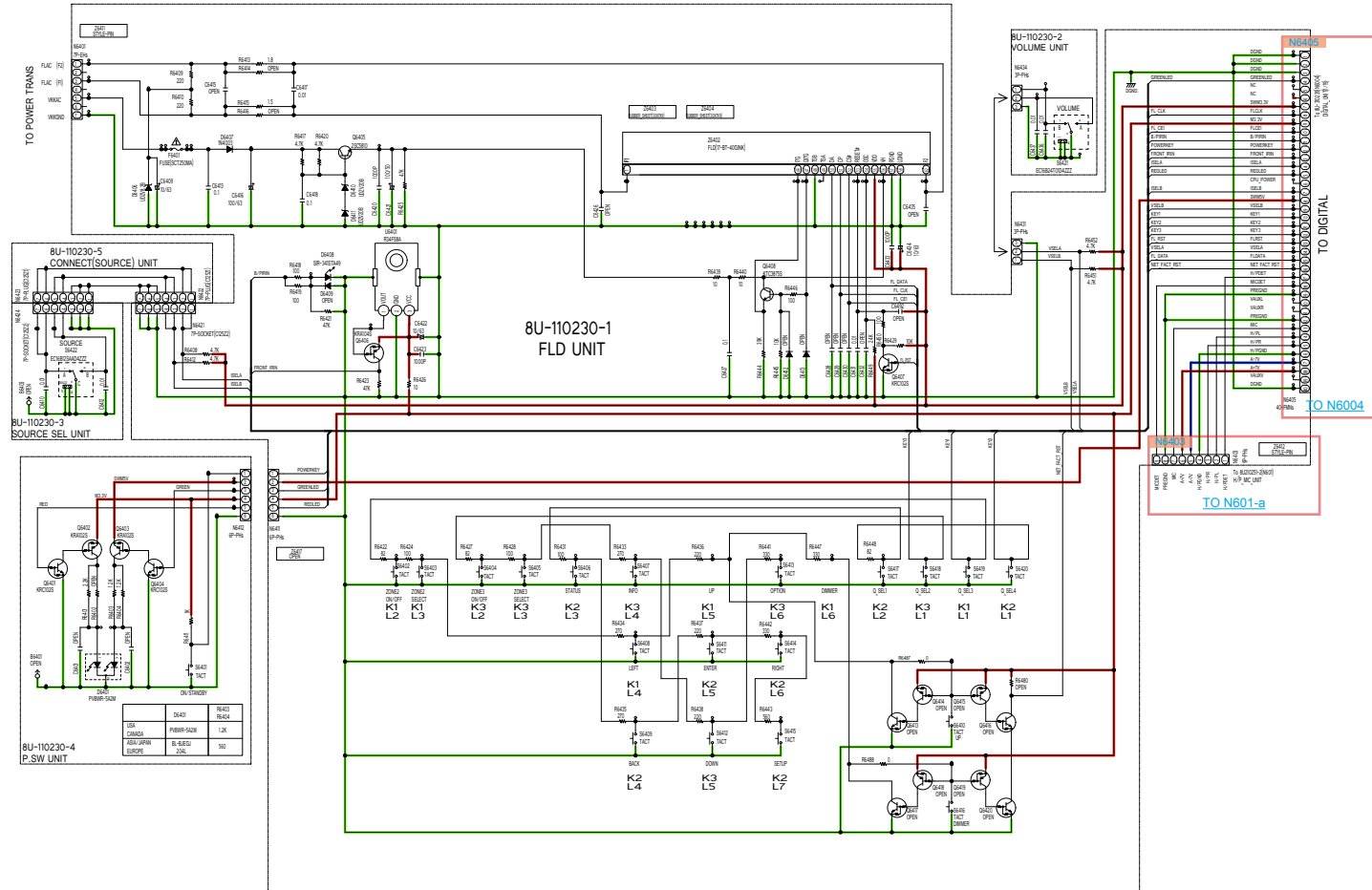

8A42	8A43	8A44	8A45	8A46	8A47	8A48	8A49	8A50	8A51	8A52	8A53	8A54	8A55	8A56
ZONE1	ZONE2	ZONE3	ZONE4	ZONE5	DMR	IP	OPN	DMR	DMR	DMR	DMR	DMR	DMR	DMR
ON OFF	SELECT	SELECT	SELECT	STATUS	ON	OFF	OFF	OFF	OFF	OFF	OFF	OFF	OFF	OFF

L1	L2	L3	L4	L5	L6	L7	
S-REL-0	ZONE2	ZONE2	LEFT	IP	DMR		
	ON/OFF	SEL.					
K1	S-REL-4	S-REL-1	STATUS	BACK	ENTER	RIGHT	STOP
		ON/OFF	SEL.	INFO	DOWN	OPTION	

GND LINE POWER+ LINE POWER- LINE AUDIO SIGNAL TMDS SIGNAL ANALOG VIDEO DIGITAL VIDEO

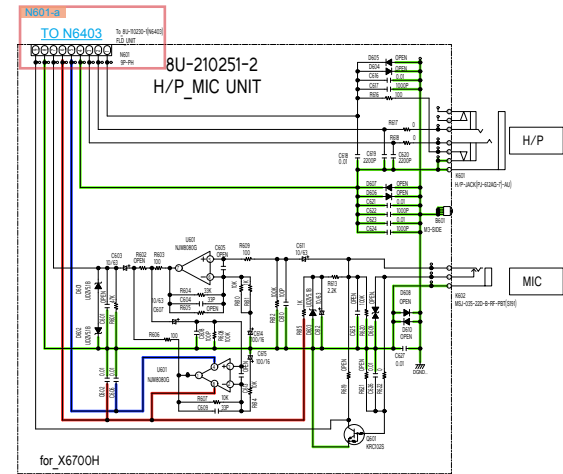

H/P_MIC

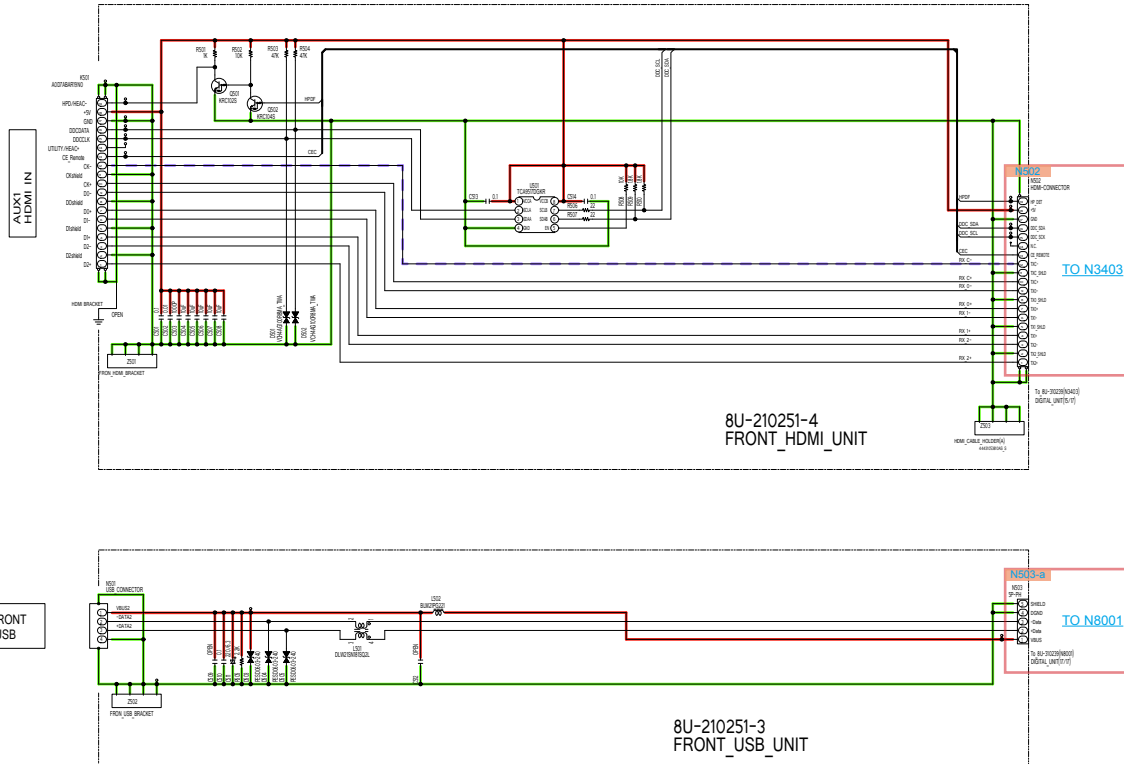

FRONT HDMI/USB

GND LINE POWER+ LINE POWER- LINE AUDIO SIGNAL TMDS SIGNAL ANALOG VIDEO DIGITAL VIDEO

DIGITAL

DIGITAL (A Side)

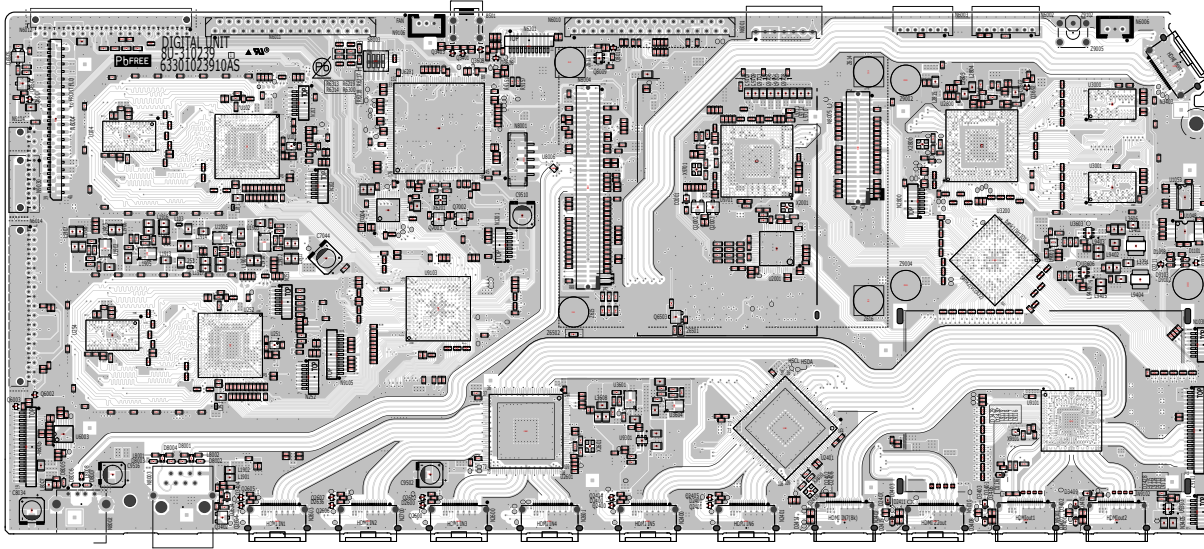

DIGITAL (B Side)

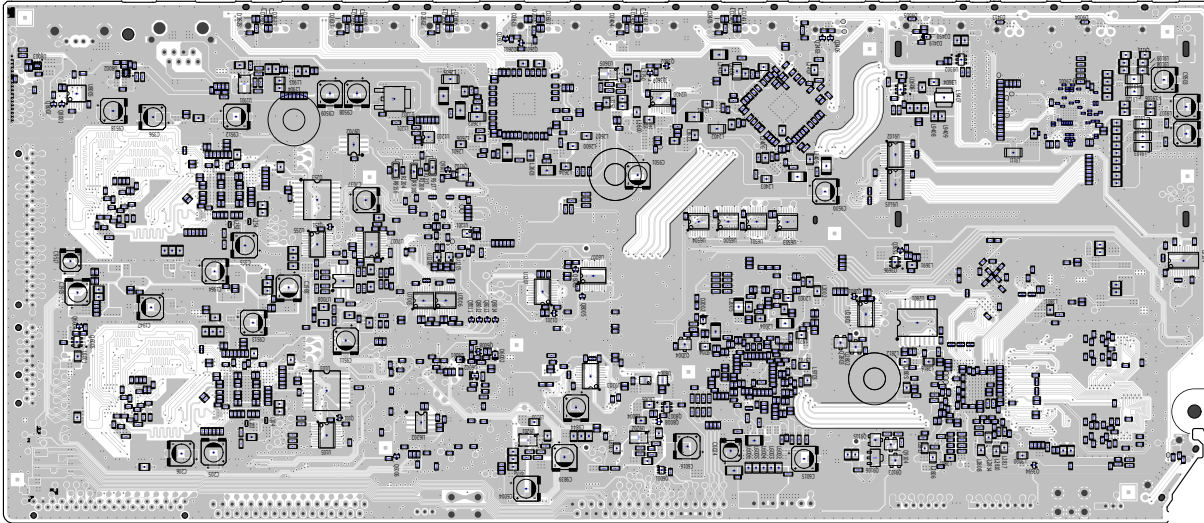

Before Servicing
This Unit

Electrical

Mechanical

Repair Information

Updating

AUDIO VIDEO, PROTECTION, CONNECT-1, TUNER IN(AVC model Only), CONNECT-4, CONNECT-2, SMPS

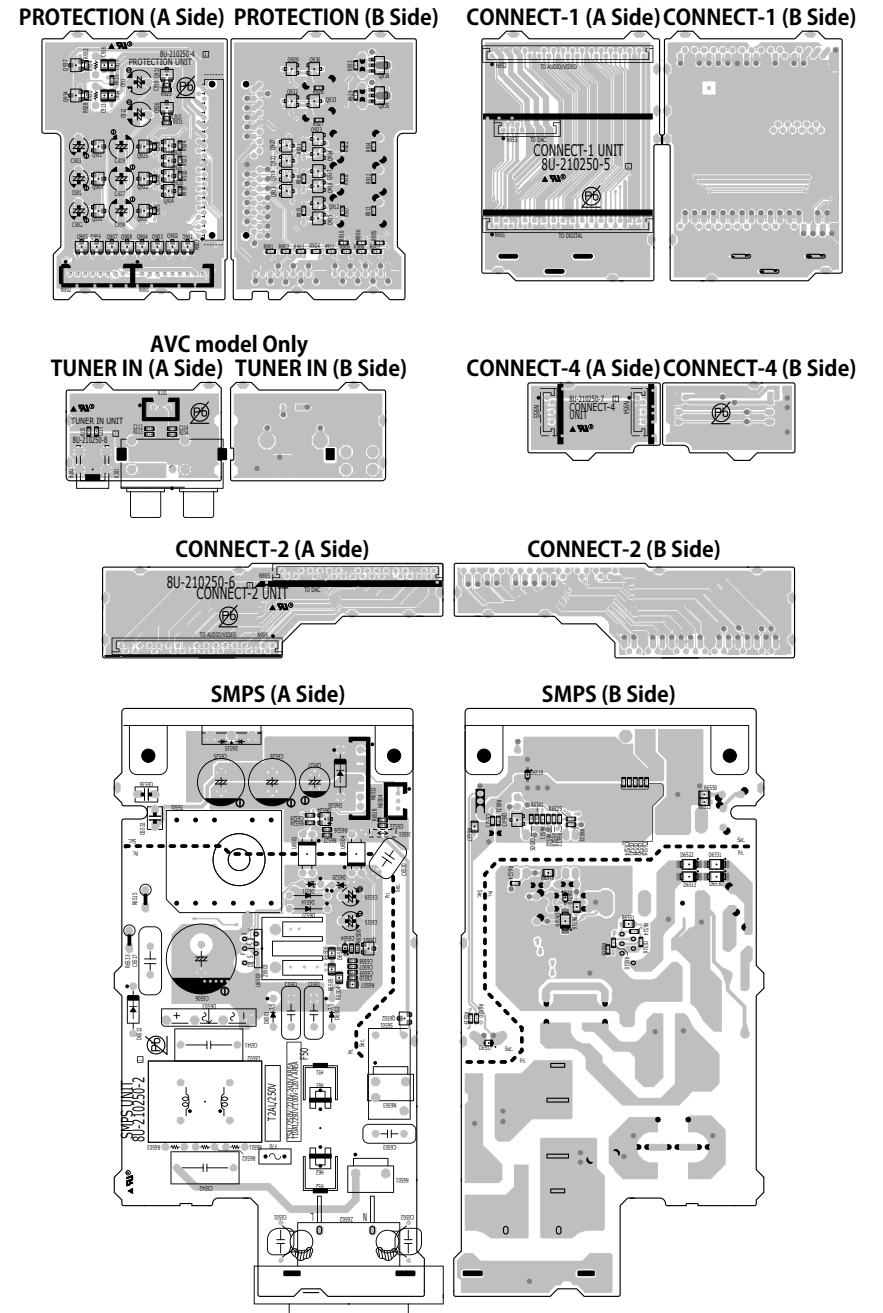
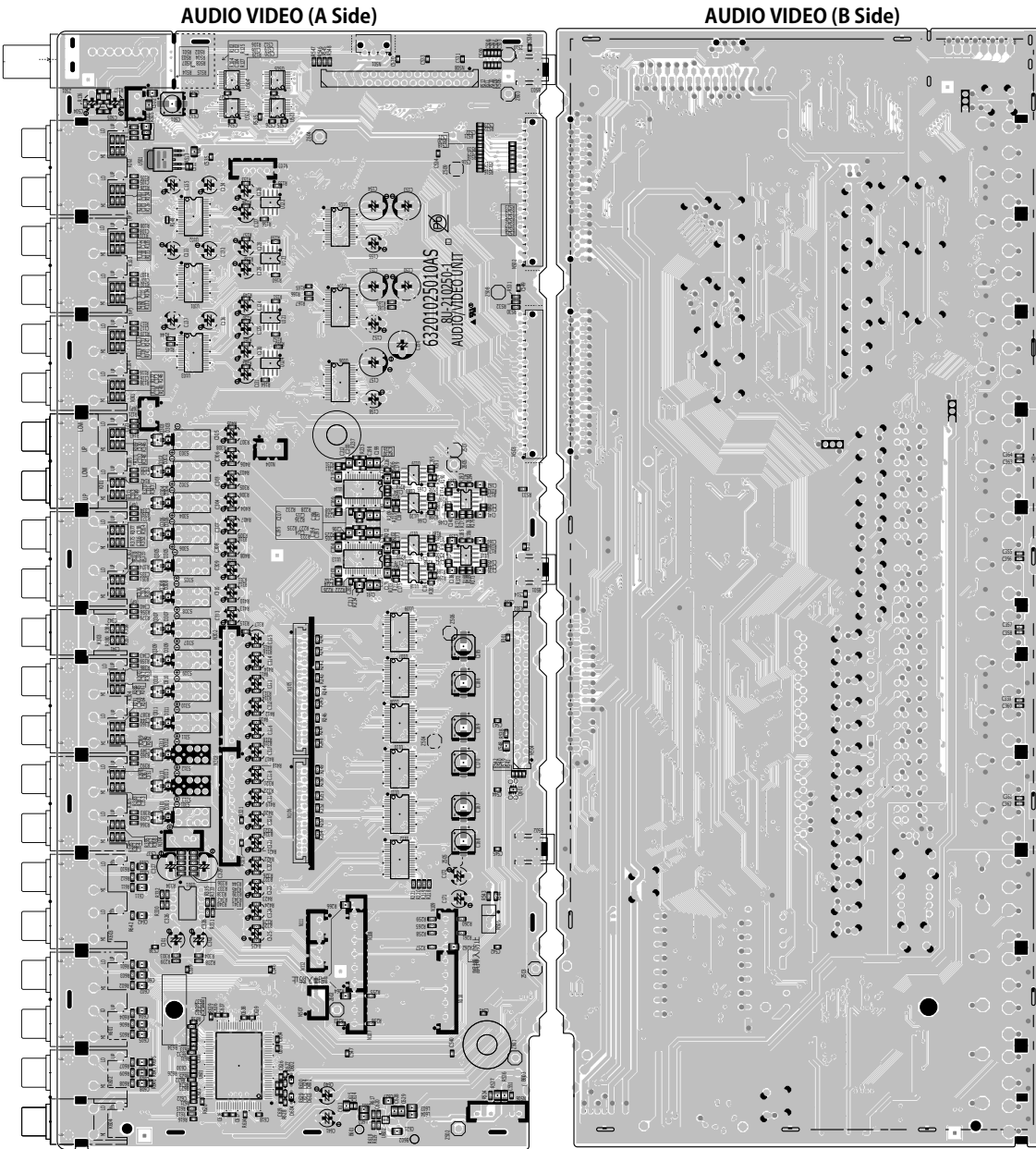

Before Servicing
This Unit

Electrical

Mechanical

Repair Information

Updating

REAR INPUT, DAC, H/P_MIC, FRONT USB, FRONT HDMI

REAR INPUT (A Side)

REAR INPUT (B Side)

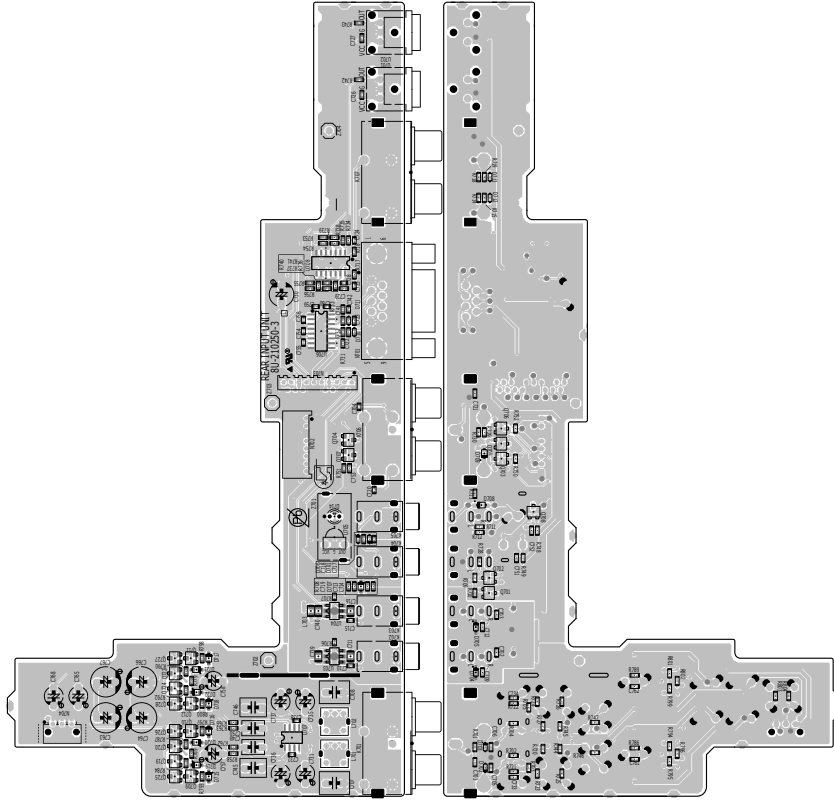

DAC (A Side)

DAC (B Side)

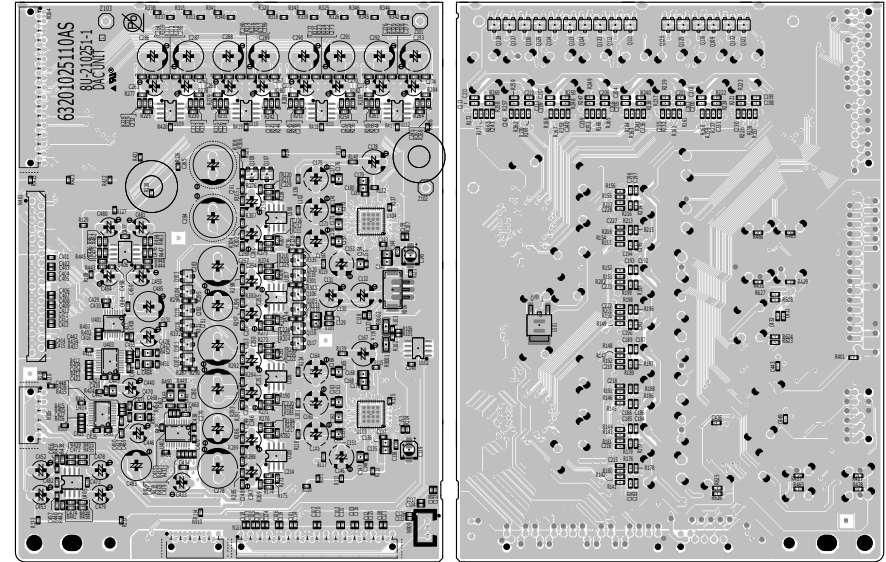

H/P_MIC (A Side)

H/P_MIC (B Side)

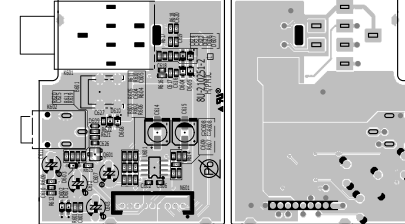

FRONT USB (A Side) FRONT USB (B Side)

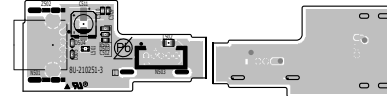

FRONT HDMI (A Side) FRONT HDMI (B Side)

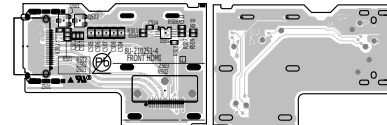

SPEAKER, HIGHT2, HIGHT3, SIDE CONNECT

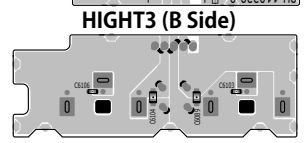
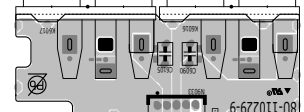
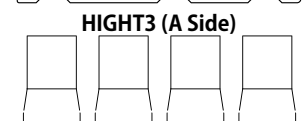
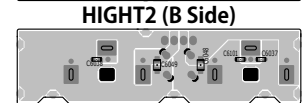
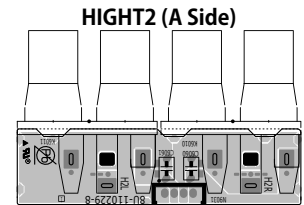
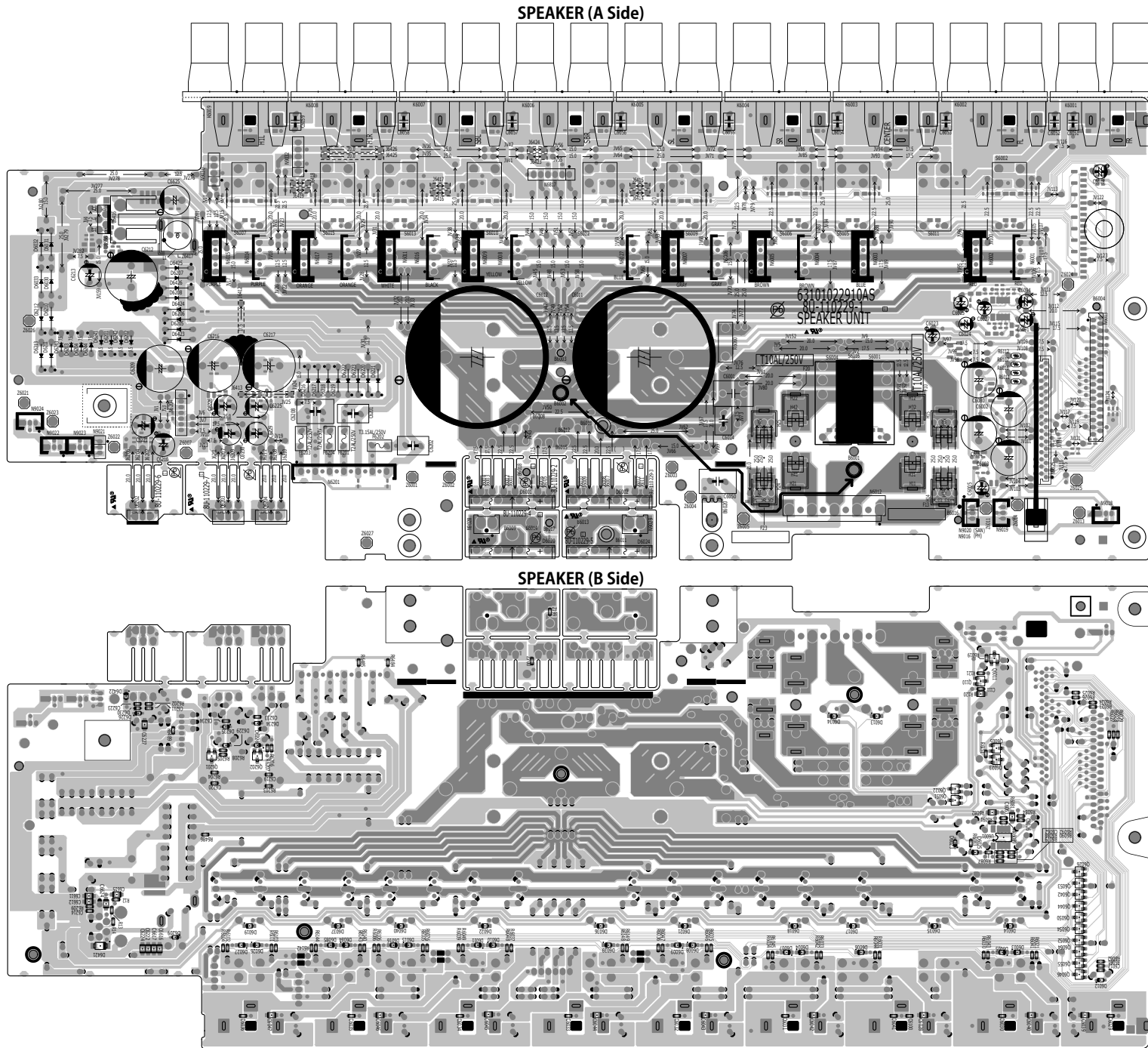

Before Servicing
This Unit

Electrical

Mechanical

Repair Information

Updating

L AMP CONNECT, R AMP CONNECT, P.AMP-1, P.AMP-2, POSISTER-1, FLD, VOLUME, SOURCE SEL, P.SW, CONNECT, COVER

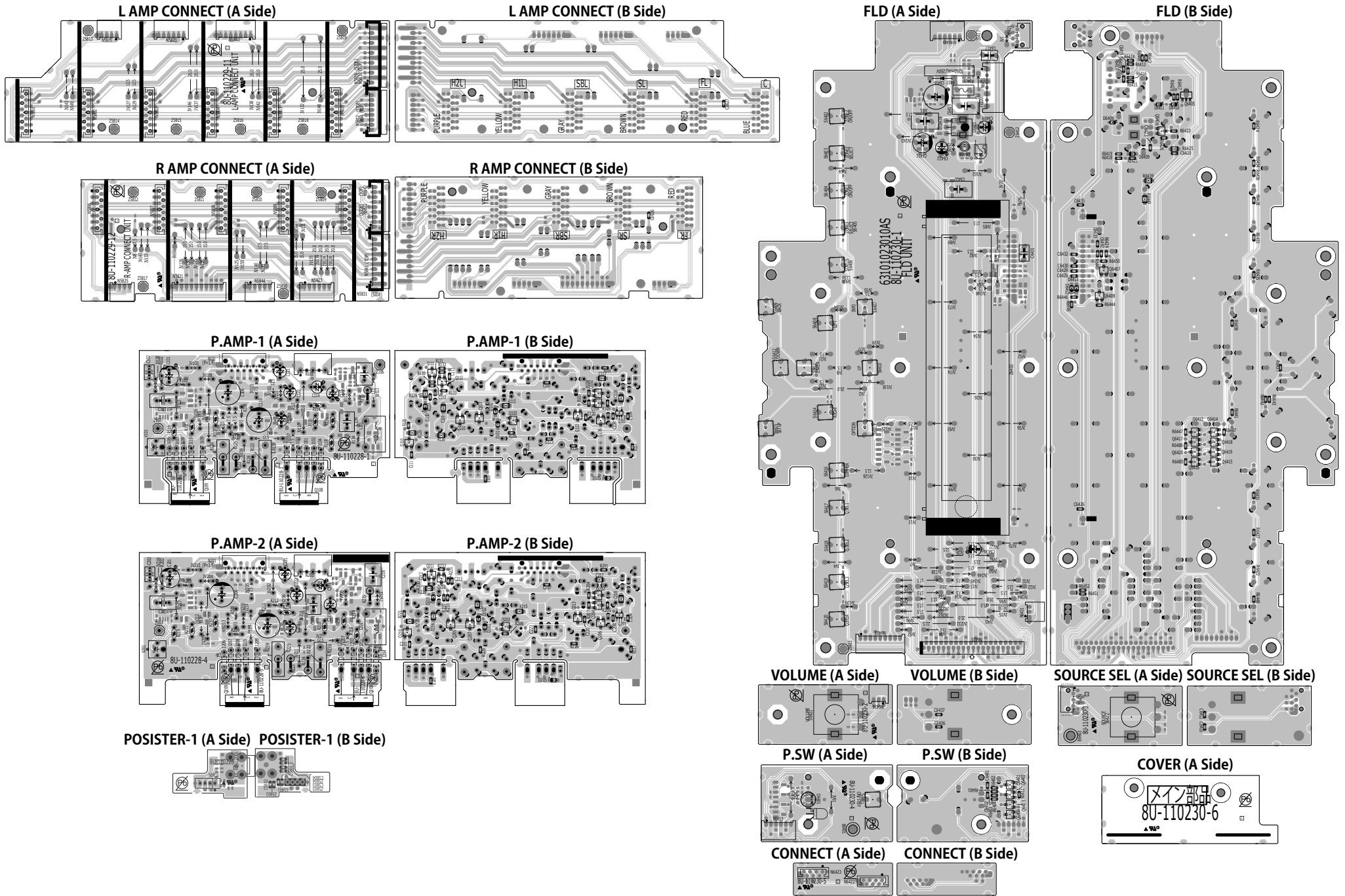

Before Servicing
This Unit

Electrical

Mechanical

Repair Information

Updating

LEVEL DIAGRAM

FRONT ch

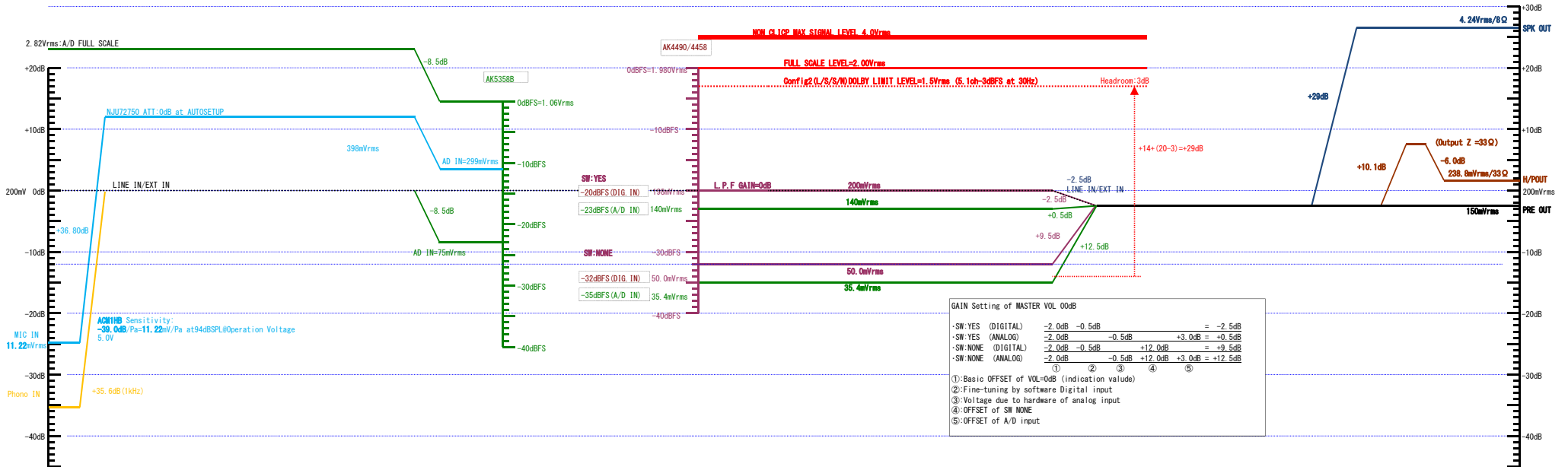
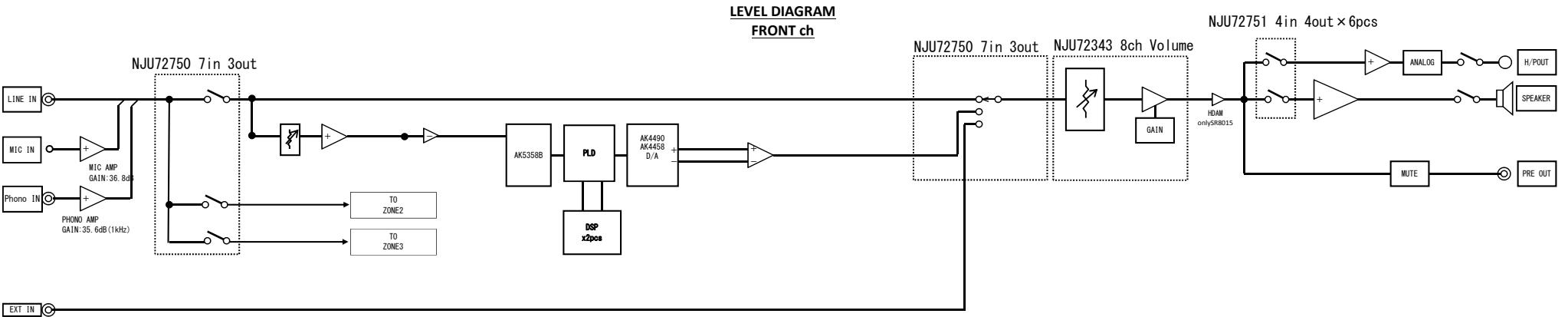

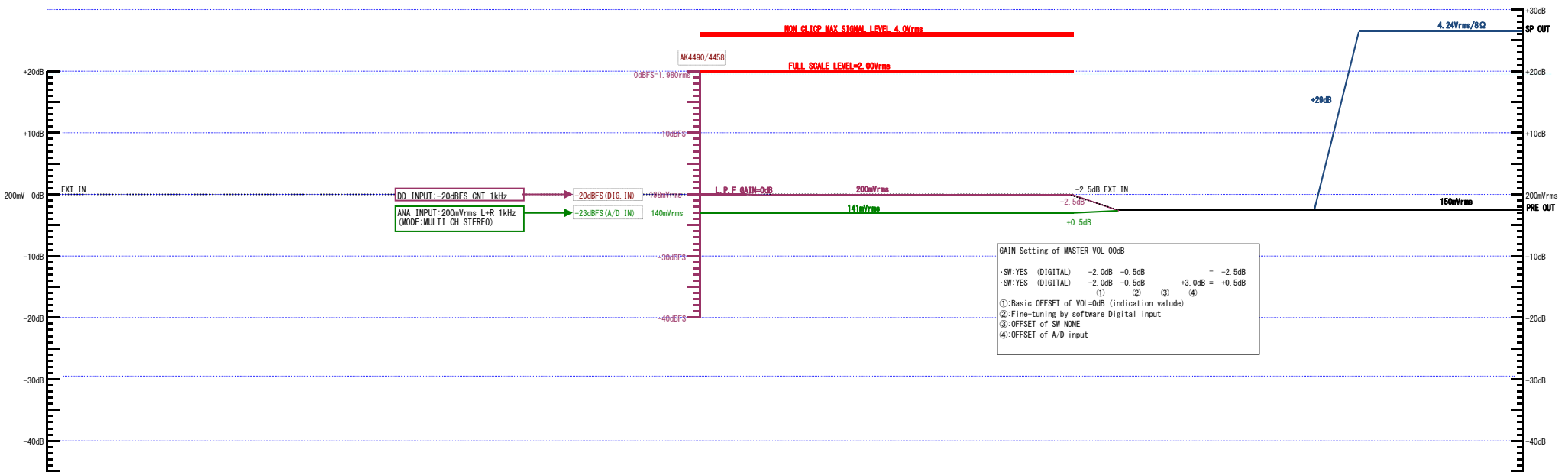
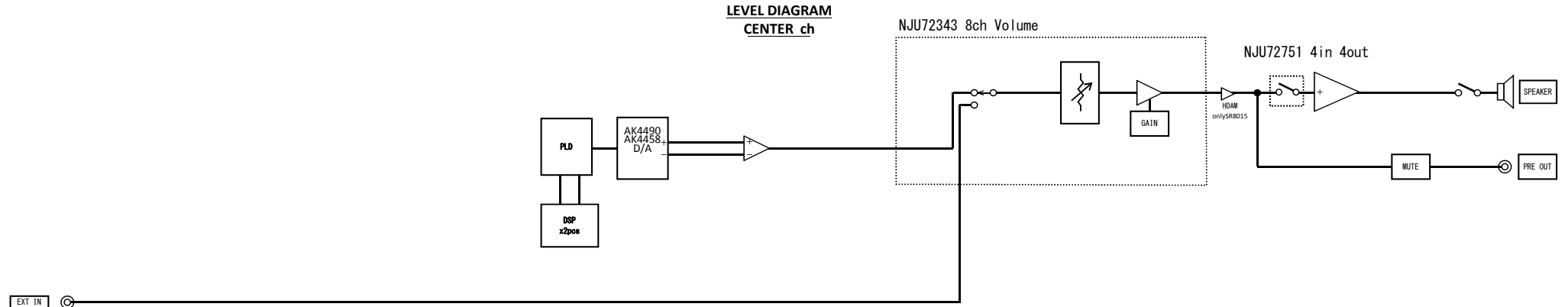

LEVEL DIAGRAM
SUBWOOFER ch

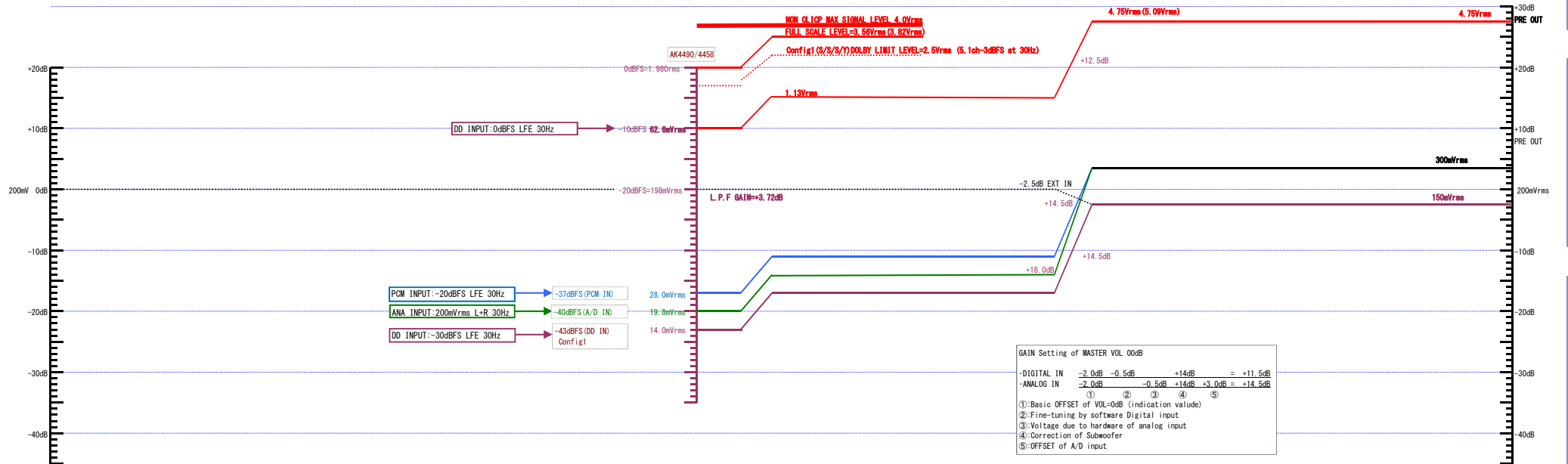
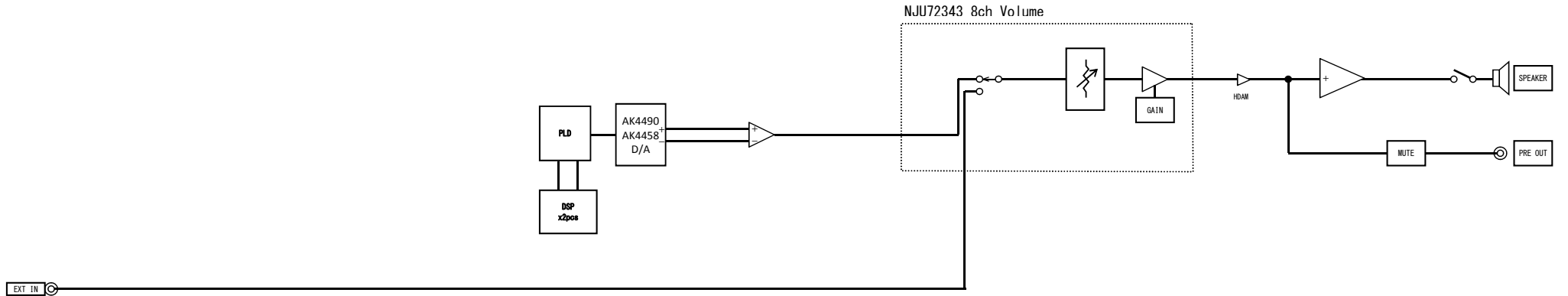

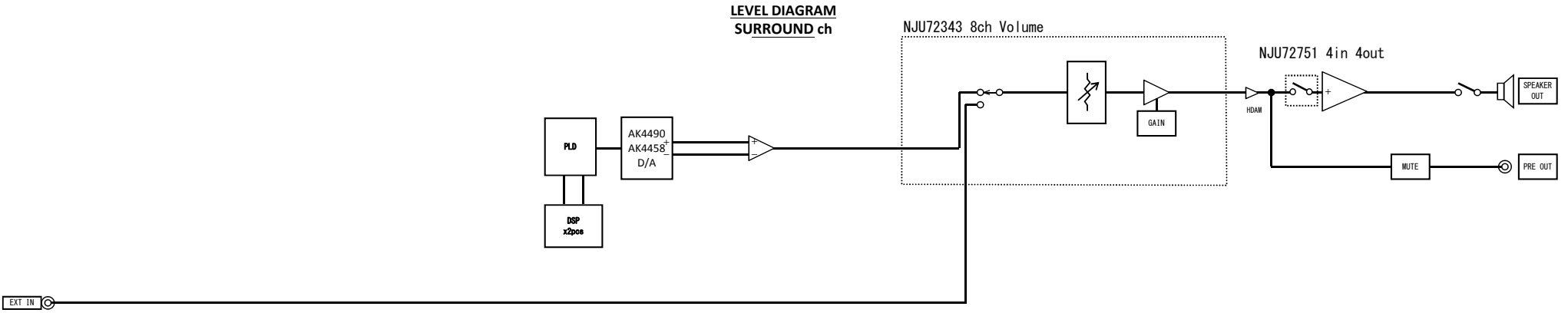

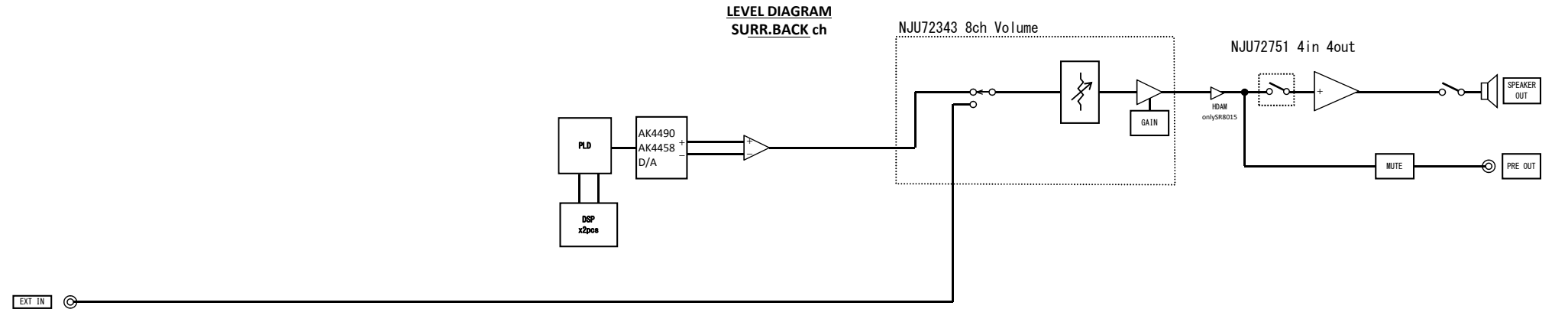

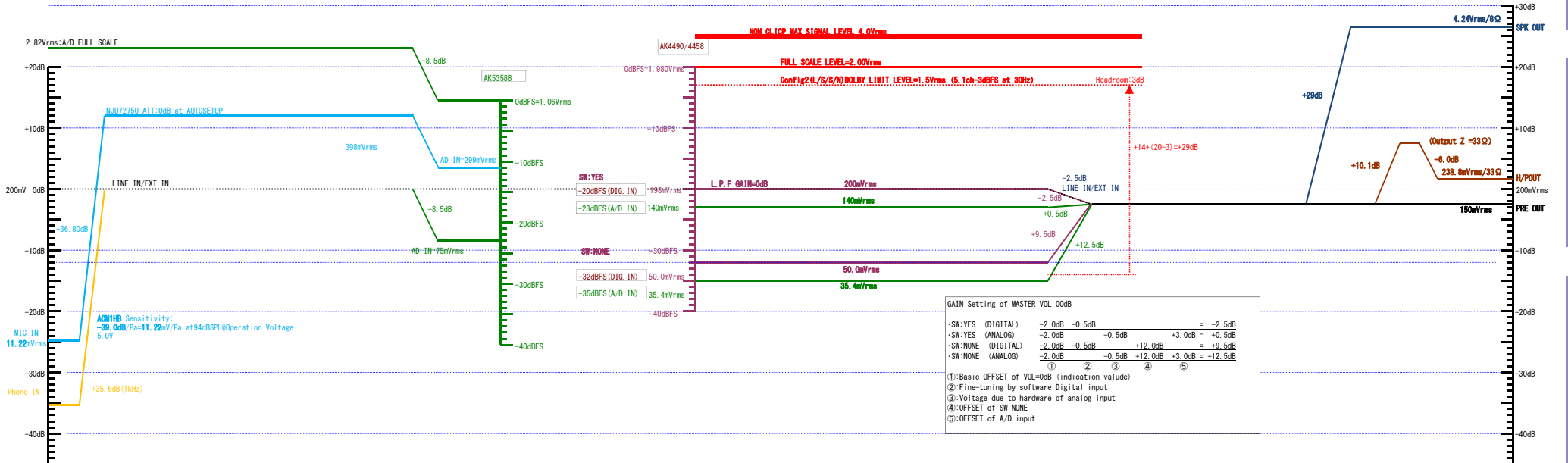
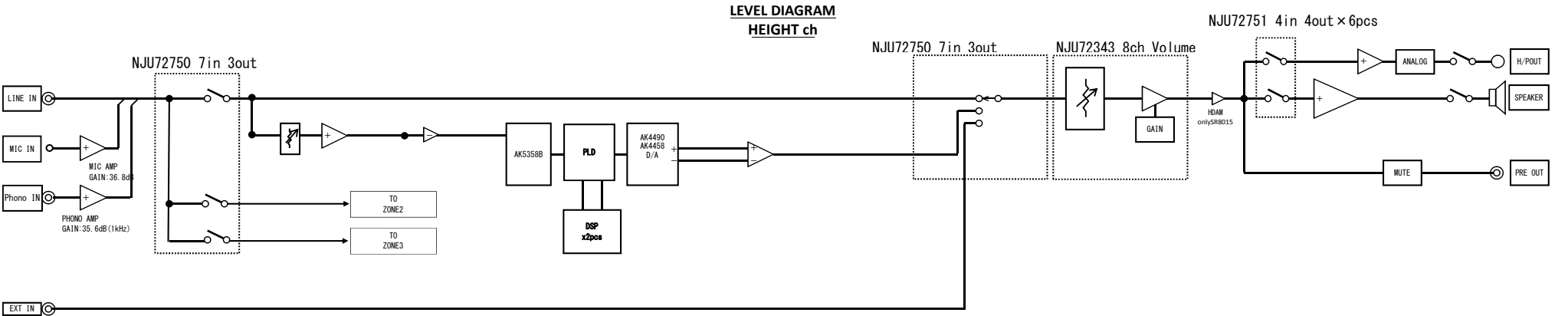

ZONE2/3 ch

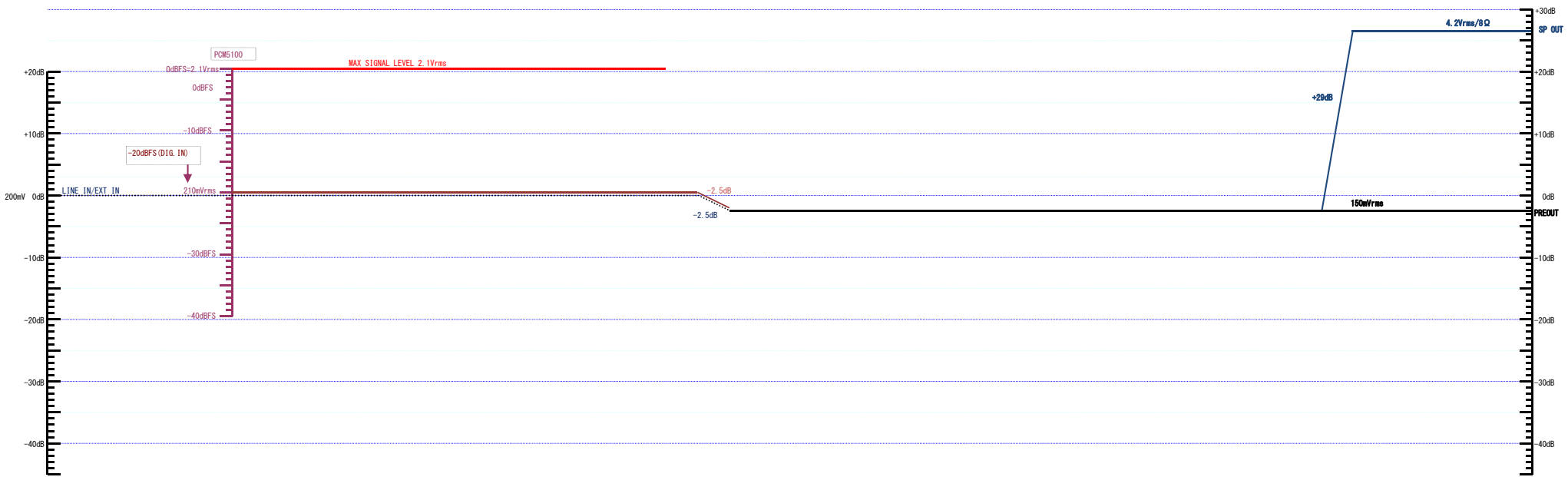
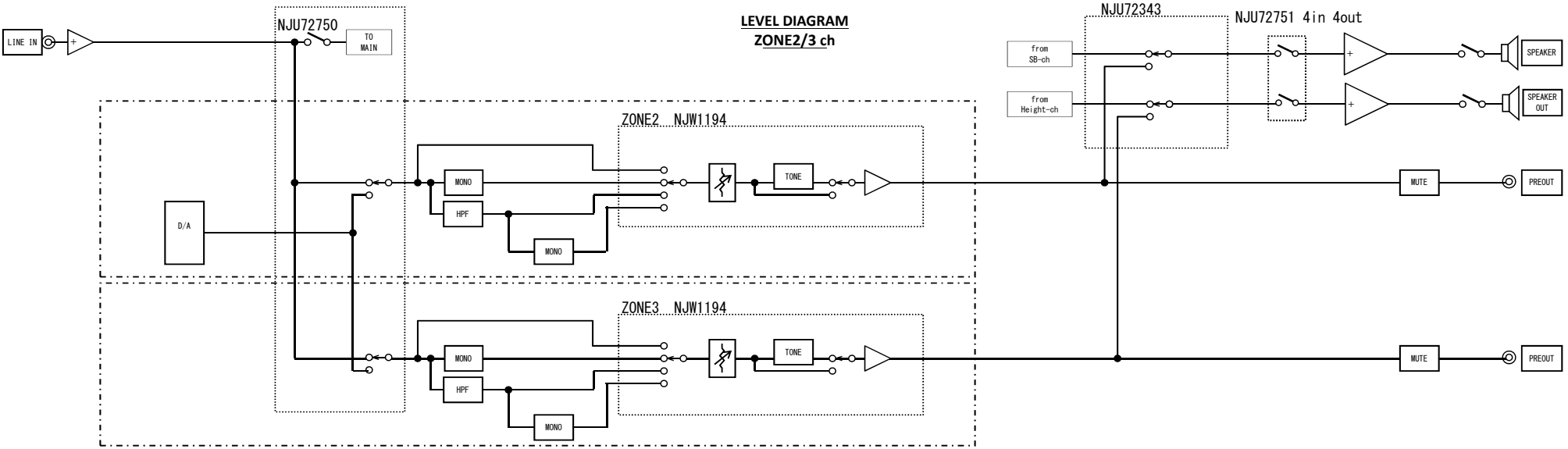

Before Servicing This Unit

Electrical

Mechanical

Repair Information

Updating

BLOCK DIAGRAM

ANALOG AUDIO DIAGRAM

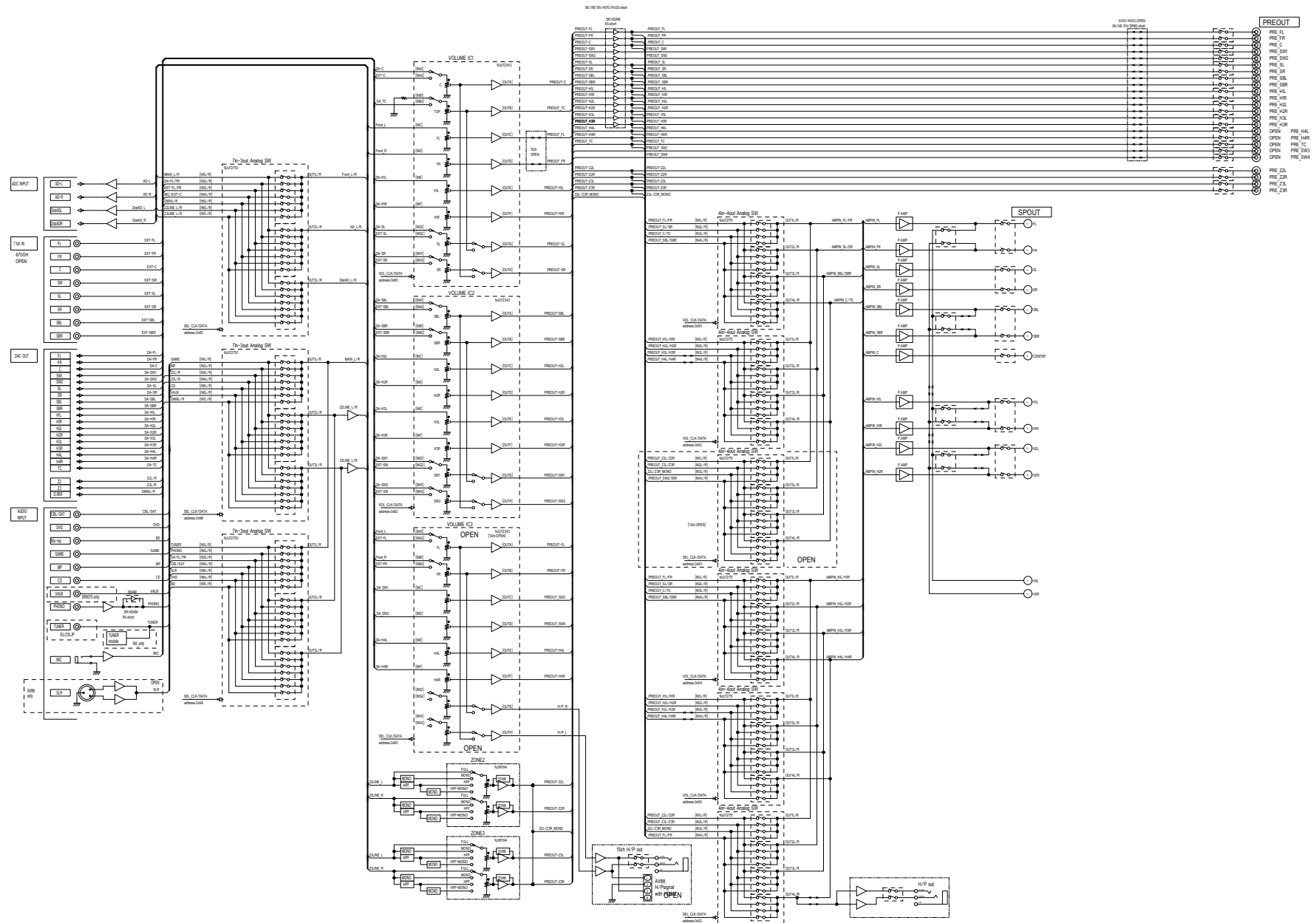

Before Servicing
This Unit

Electrical

Mechanical

Repair Information

Updating

AVR-X6700/SR8015 DIGITAL AUDIO/NETWORK BLOCK DIRAGRAM

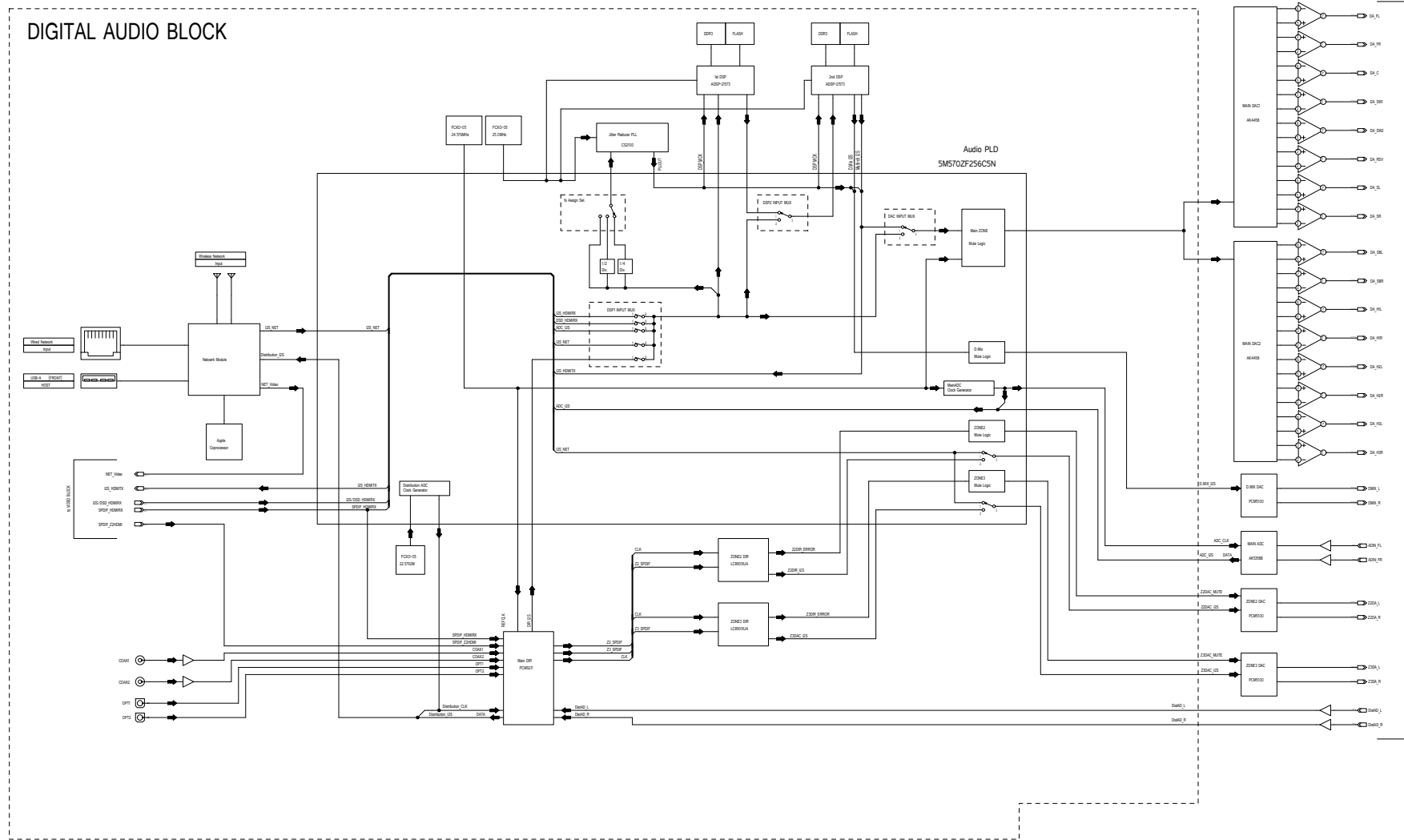

VIDEO DIAGRAM

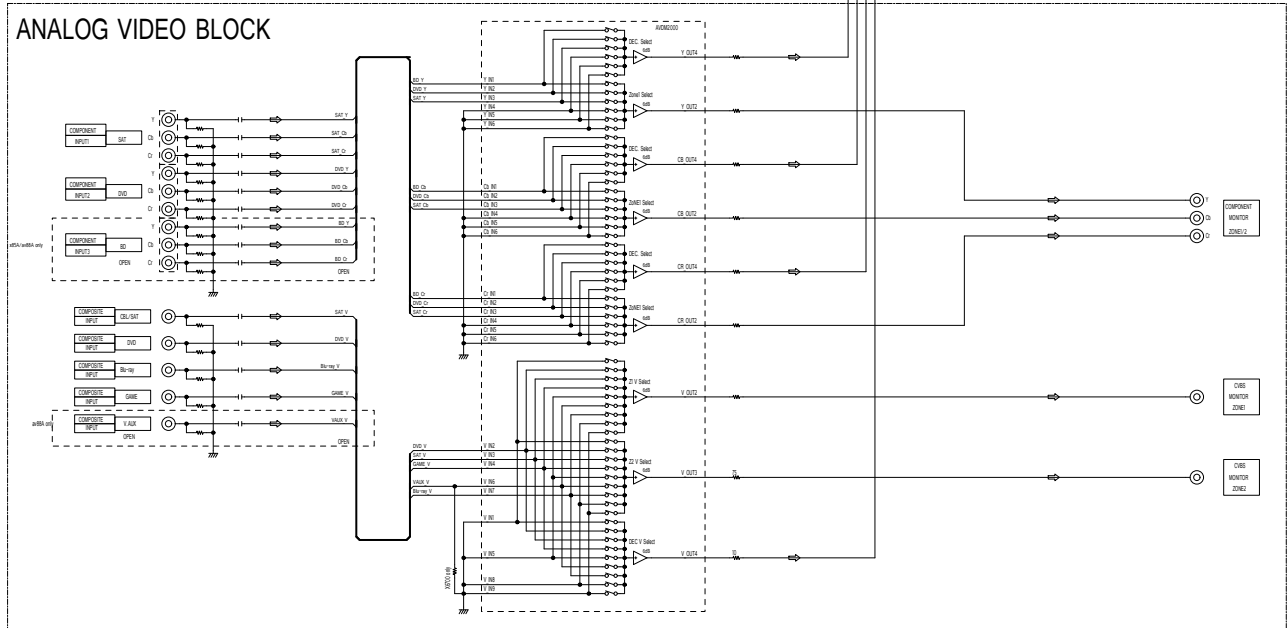
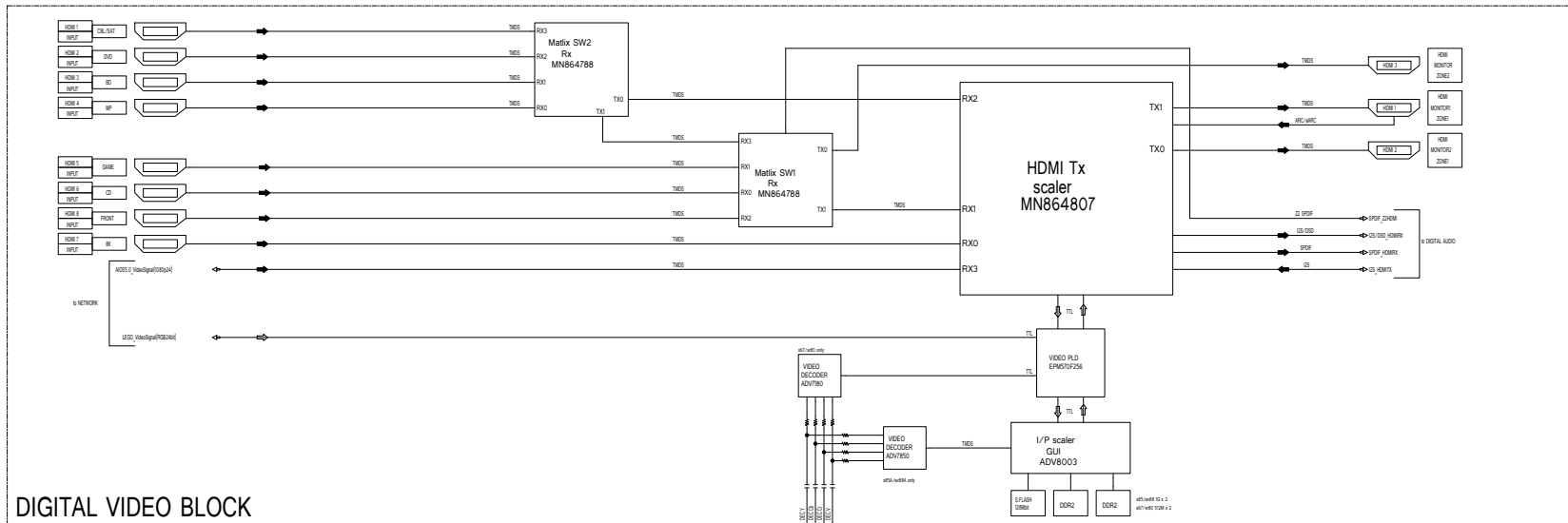

●FY21model BLOCK DIAGRAM (P.SUPPLY)

DIGITAL PCB

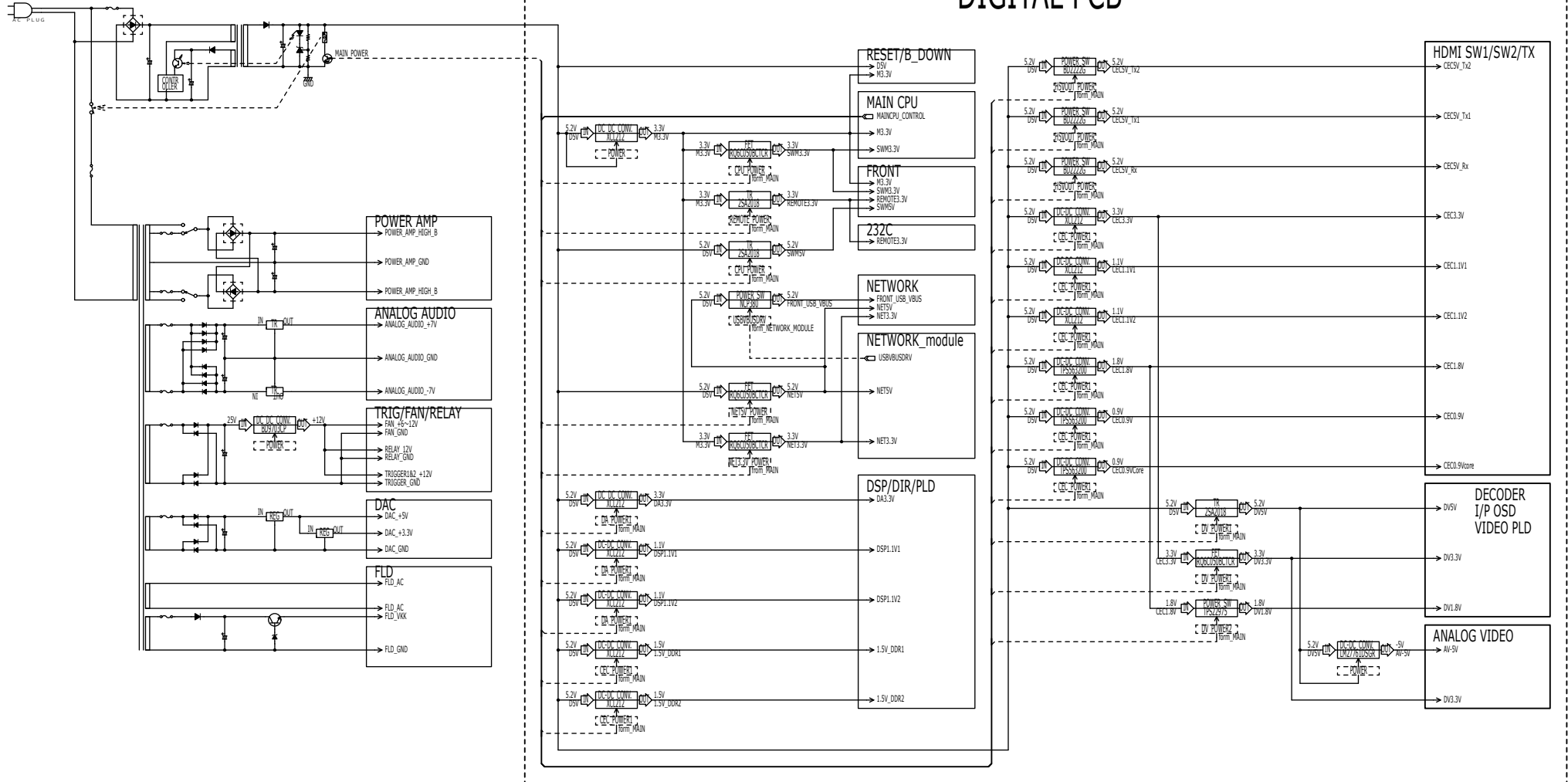

Before Servicing
This Unit

Electrical

Mechanical

Repair Information

Updating

Only major semiconductors are shown, general semiconductors etc. are omitted to list.
The semiconductor which described a detailed drawing in a schematic diagram are omitted to list.

1. IC's

R5F564MJCDFC (DIGITAL : U6201)

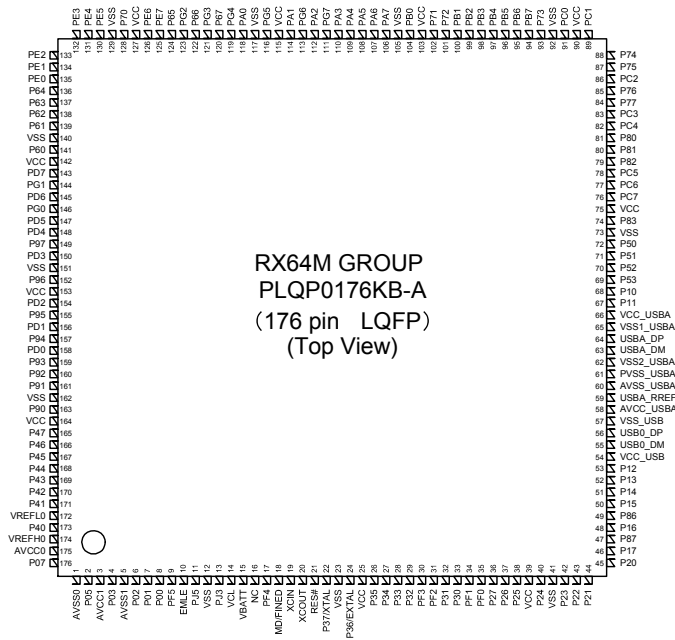

RX64M GROUP
PLQP0176KB-A
(176 pin LQFP)
(Top View)

Terminal Functions

Pin	Pin Name	Symbol	I/O	Pu/Pd	STBY	STOP	CEC STBY	Function
1	AVSS0	AVSS0	-	-	-	-	-	Ground pin
2	P05/IRQ13	POWER_KEY	I	M3VPu	I	I	I	Detect Power switch (Release from wait mode, set to interrupt)
3	AVCC1	AVCC1	-	-	-	-	-	Power supply pin
4	P03/IRQ11	RED_LED	O	L/H	L	H	H	POWER/STANDBY LED control pin
5	AVSS1	AVSS1	-	-	-	-	-	Ground pin
6	P02/SCK6/IRQ10/AN120	FANDET(LOW/MID/HIGH)	I	SW3VPu	I	I	I	Thermal detection input (for FAN control) (A/D converter)
7	P01/RXD6/IRQ9/AN119	RXD_MI2320	I	Pd	I	I	I	External data input port (for AMX/FW update via 232C): Connector is FFC
8	P00/TXD6/IRQ8/AN118	TXD_MO232I	O	-	L	L	L	External data output port (for AMX/FW update via 232C): Connector is FFC
9	PF5/IRQ4	WHITE LED(X6700H(NA)) / GREEN LED(X6700H(EU/CH/JP),SR8015(ALL))	O	-	L	L	L	POWER LED control pin
10	EMLE	EMLE	I	Pd	-	-	-	E20 Emulator control pin (On chip Emulator is used, this pin should be High. When it is not used, it should be Low)
11	PJ5	VSEL_A	I	-	I	I	I	Master Volume (Rotary encoder) signal input pin
12	VSS	VSS	-	-	-	-	-	Ground pin
13	PJ3	VSEL_B	I	-	I	I	I	Master volume (Rotary encoder) signal input pin
14	VCL	VCL	I	-	-	-	-	Smoothing capacitor connection pin

Pin	Pin Name	Symbol	I/O	Pu/Pd	STBY	STOP	CEC STBY	Function
15	VBATT	VBATT	-	-	-	-	-	Power supply pin
16	NC	NC	I	Pd	-	-	-	NC(Pull down)
17	TRST#/PF4	TRST#/NC(NORMAL)	I/I	Pd	I/I	I/I	I/I	E20 Emulator control pin / When normal operating mode, set to input
18	MD/FINED	MD	I	M3VPu	I	I	I	Pins for setting the operating mode (Select the Boot mode, User boot mode, or Single chip mode)
19	XCIN	XCIN	I	Pd	-	-	-	NC(Pull down)
20	XCOU	XCOU	I	-	-	-	-	NC(open)
21	RES#	RESET	I	-	-	-	-	Reset signal input pin
22	XTAL/P37	XTAL	I	-	-	-	-	Pins for a crystal resonator (Xin: 12MHz × 10)
23	VSS	VSS	-	-	-	-	-	Ground pin
24	EXTAL/P36	EXTAL	-	-	-	-	-	Pins for a crystal resonator (Xin: 12MHz × 10)
25	VCC	VCC	-	-	-	-	-	Power supply pin
26	UPSEL/P35(IN)/NMI	NC(X6700H) / DOOR DET(SR8015)	I	SW3VPu / SW3VPu	I	I	I	Front trap door open/close detect input pin (High: Door open)
27	P34/SCK6/SCK0/IRQ4	BDOWN	I	-	I	I	I	Detect power down
28	P33/TIOCD0/RXD6/RXD0/IRQ3-DS	RC_IN	I	-	I	I	I	Remote input
29	P32/TIOCC0/TXD6/TXD0/IRQ2-DS	NC(X6700H) / FLASHER_IN(SR8015)	O/I	Pd	L/I	L/I	L/I	IR Flasher control signal input (When standby mode, set to interrupt)
30	TMS/PF3	TMS/NC(NORMAL)	I/I	M3VPu	-/I	-/I	I	E20 Emulator control pin/When normal operating mode, set to input.
31	TDI/PF2/RXD1	TDI/RXD_MITSUBISHI	I/I/I	M3VPu	-/I	-/I	I	E20 Emulator control pin/Mitsubishi writer control pin/When normal operating mode, set to input.
32	P31/IRQ1-DS	TU_INT(X6700H/ SR8015(NA)) / NC(X6700H/ SR8015(EU/CH/JP))	I	-	L	L	L	TUNER control
33	P30/RXD1	TU_SDA(X6700H/ SR8015(NA)) / NC(X6700H/ SR8015(EU/CH/JP))	I_O	-	L	L	L	TUNER control
34	TCK/FINEC/PF1/SCK1	TCK/NC(NORMAL)	I/I	M3VPu	-/I	-/I	I	E20 Emulator control pin/When normal operating mode, set to input.
35	TD0/TXD1/PF0	TDO/TXD_MITSUBISHI	O/O/I	M3VPu	-/I	-/I	I	E20 Emulator control pin/Mitsubishi writer control pin/When normal operating mode, set to input.
36	P27/SCK1	TU_SEN(X6700H/ SR8015(NA)) / NC(X6700H/ SR8015(EU/CH/JP))	O	-	L	L	L	TUNER control
37	P26/TXD1	TU_SCL(X6700H/ SR8015(NA)) / NC(X6700H/ SR8015(EU/CH/JP))	O	-	L	L	L	TUNER control
38	P25/RXD3	VOL_DATA	O	-	L	L	L	Volume control pin (NJU2343)
39	VCC	VCC	-	-	-	-	-	Power supply pin
40	P24/SCK3	NC(X6700H) / KILL_IR(SR8015)	O	-	L	L	L	Front IR disable control pin
41	VSS	VSS	-	-	-	-	-	Ground pin
42	P23/TXD3/CTS0#/RTS0#	E_RTS_MOEI	O	Pd (BCM58305 Internal Pd)	L	L	L	Network module control pin
43	P22/SCK0	E_CTS_MIEO	I	Pd (on board + BCM58305 Internal Pd)	I	I	I	Network module control pin
44	P21/RXD0/IRQ9	E_RXD_MIEO	I	Pd (on board + BCM58305 Internal Pd)	I	L	I	Network module control pin
45	P20/TXD0/IRQ8	E_TXD_MOEI	O	Pd (BCM58305 Internal Pd)	L	L	L	Network module control pin
46	P17/SCK1/TXD3/IRQ7	NET_FACT_RST	O(ODR)	Pu (BCM58305 Internal Pd)	Z	Z	Z	Network module control pin
47	P87/TXD10/TIOCA2	NC(X6700H) / RC_OUT(SR8015)	O	-	L/H	L/L	L/H	Remote code(RC-5) output pin
48	P16/TXD1/RXD3/IRQ6	NET5V_POWER	O	-	L	L	L	Network power supply control pin

Pin	Pin Name	Symbol	I/O	Pu/Pd	STBY	STOP	CEC STBY	Function
49	P86/RXD10	SEL_DATA	O		L	L	L	Audio selector control pin (NJU27250/72751)
50	P15/RXD1/SCK3/IRQ5	AEXP_STB	O		L	L	L	Expander(MC14094) control pin
51	P14/IRQ4	AEXP_OE	O		L	L	L	Expander(MC14094) control pin
52	P13/TXD2/IRQ3	AEXP_CLK	O		L	L	L	Expander(MC14094) control pin
53	P12/RXD2/IRQ2	AEXP_DATA	O		L	L	L	Expander(MC14094) control pin
54	VCC_USB	VCC_USB	-		-	-	-	Power supply pin
55	USB0_DM	USB0_DM	-		-	-	-	NC (open)
56	USB0_DP	USB0_DP	-		-	-	-	NC (open)
57	VSS_USB	VSS_USB	-		-	-	-	Ground pin
58	AVCC_USBA	AVCC_USBA	-		-	-	-	Power supply pin
59	USBA_PREF	USBA_PREF	-		-	-	-	NC (open)
60	AVSS_USBA	AVSS_USBA	-		-	-	-	Ground pin
61	PVSS_USBA	PVSS_USBA	-		-	-	-	Ground pin
62	VSS2_USBA	VSS2_USBA	-		-	-	-	Ground pin
63	USBA_DM	USBA_DM	-		-	-	-	NC (open)
64	USBA_DP	USBA_DP	-		-	-	-	NC (open)
65	VSS1_USBA	VSS1_USBA	-		-	-	-	Ground pin
66	VCC_USBA	VCC_USBA	-		-	-	-	Power supply pin
67	P11/SCK2/IRQ1	CEC_OUT	O		L	L	-	CEC-D control pin
68	P10/IRQ0	CEC_IN	I		I	I	I	CEC-D control pin
69	P53	ADV8003_SPL_CS	O		L	L	L	GUI (ADV8003) control pin
70	P52/RXD2	ADV8003_SPL_MI	I		L	L	L	GUI (ADV8003) control pin
71	P51/SCK2	ADV8003_SPL_CLK	O		L	L	L	GUI (ADV8003) control pin
72	P50/TXD2	ADV8003_SPL_MO	O		L	L	L	GUI (ADV8003) control pin
73	VSS	VSS	-		-	-	-	Ground pin
74	P83/SCK10	IP_RST	O	Pd	I	I	L	Scaler w/ GUI(ADV8003) Reset control pin
75	VCC	VCC	-		-	-	-	Power supply pin
76	UB/PC7/TXD8/IRQ14	UB	I	Pd	-	-	-	Pins for setting the boot mode (select the Boot Mode or User Boot Mode)
77	PC6/RXD8/IRQ13	AVSDA	I/O	DV3VPu	O/L	O/L	L	VIDEO I2C control pin for ADV8003/ADV7180/ADVM2000
78	PC5/SCK8	AVSCL	I/O	DV3VPu	O/L	O/L	L	VIDEO I2C control pin for ADV8003/ADV7180/ADVM2000
79	P82/TXD10	DSP_MOSI	O	DA3VPu	L	L	L	DSP (ADI) control pin
80	P81/RXD10	DSP_MISO	I	DA3VPu	L	L	L	DSP (ADI) control pin
81	P80/SCK10	DSP_CLK	O	DA3VPu	L	L	L	DSP (ADI) control pin
82	PC4/SCK5	DSP1FLAG0	I	Pd	L	L	L	DSP (ADI) interrupt signal input pin
83	PC3/TXD5	DSP2FLAG0	I	Pd	L	L	L	DSP (ADI) interrupt signal input pin
84	P77/TXD11	H5VOUT_POWER	O		L	L	L	HDMI 5V power supply control pin
85	P76/RXD11	DSP1_CORE1_FLAG3	I	Pd	L	L	L	DSP (ADI) interrupt signal input pin
86	PC2/RXD5	DSP_RST	O		L	L	L	DSP (ADI) reset control pin
87	P75/SCK11	CEC_POWER2	O		L	L	H	CEC standby power control (for CEC Standby Mode 3)
88	P74	DSP1CS	O	DA3VPu	L	L	L	DSP (ADI) control pin
89	PC1/SCK5/IRQ12	DAC_PLD_ERR	I		L	L	L	Detect PLD error (from Audio PLD)
90	VCC	VCC	-		-	-	-	Power supply pin
91	PC0/IRQ14	DSP2CS	O	DA3VPu	L	L	L	DSP (ADI) control pin
92	VSS	VSS	-		-	-	-	Ground pin
93	P73	TX_FAN	O		L	L	L	HDMI TX FAN control (ON:"H")
94	P87/TXD9	HSDA	I/O	CEC3VPu	L	L	L	HDMI I2C control pin for MN864788/MN864807
95	P86/RXD9	H_SCL	I/O	CEC3VPu	L	L	L	HDMI I2C control pin for MN864788/MN864807
96	P85/SCK9	NC(X6700H) / AC_RL1(SR8015)	O		L	L	L	AC relay control pin for the rush resistor
97	P84	APLD_CS	O		L	L	L	Audio PLD (5M570ZF256C5N) control pin

Pin	Pin Name	Symbol	I/O	Pu/Pd	STBY	STOP	CEC STBY	Function
98	PB3/SCK4/SCK6	APLD_DATA/DAC_DATA	O		L	L	L	Audio PLD (5M570ZF256C5N) control pin/DAC (AK4458) control pin
99	PB2	APLD_CLK/DAC_CLK	O		L	L	L	Audio PLD (5M570ZF256C5N) control pin/DAC (AK4458) control pin
100	PB1/TXD4/TXD6/IRQ4-DS	DAC_MS	O		L	L	L	DAC (AK4458) control pin
101	P72	DAC_RST	O		L	L	L	DAC (AK4458) control pin
102	P71	Z2PLD_ERR	I	-	L	L	L	Detect PLD error (from Audio PLD)
103	VCC	VCC	-		-	-	-	Power supply pin
104	PB0/RXD4/RXD6/IRQ12	Z3PLD_ERR	I	-	L	L	L	Detect PLD error (from Audio PLD)
105	VSS	VSS	-		-	-	-	Ground pin
106	PA7	ISEL_A	I		I	I	I	Input selector (Rotary encoder) signal input pin
107	PA6	ISEL_B	I		I	I	I	Input selector (Rotary encoder) signal input pin
108	PA5	VOL_CLK	O		L	L	L	Volume control pin (NJU72343)
109	PA4/TXD5/SSDA5/IRQ5-DS	THERMAL_H	I	SW3VPU	I	L	I	Protection detect signal input pin
110	PA3/RXD5/SSCL5	MVOL_MUTE	O		L	L	L	Volume control pin (NJU72343)
111	TRDATA3/PG7	REMOTE_POWER(232C)	O		L	L	L	232C power supply (REMOTE 3.3V) control pin
112	PA2/RXD5	NC	O		L	L	L	NC
113	TRDATA2/PG6	ZVOL_DATA	O		L	L	L	ZONE 2 volume control pin (NJW1194)
114	PA1/SCK5/IRQ11	ZVOL_CLK	O		L	L	L	ZONE 2 volume control pin (NJW1194)
115	VCC	VCC	-		-	-	-	Power supply pin
116	TRCLK/PG5	ZVOL_STB	O		L	L	L	ZONE 2 volume control pin (NJW1194)
117	VSS	VSS	-		-	-	-	Ground pin
118	PA0	H5V_DET	I	Pd	I	I	I	HDMI IN 5V detect signal pin
119	TRSYNC/PG4	FL_RST	O		L	L	L	FL display control pin
120	P67/IRQ15	FL_CE1	O		L	L	L	FL display control pin
121	TRDATA1/PG3	FL_CLK	O		L	L	L	FL display control pin
122	P66	FL_DATA	O		L	L	L	FL display control pin
123	TRDATA0/PG2	NC(X6700H) / FL_CE2(SR8015)	O		L	L	L	FL display control pin
124	P65	NC(X6700H) / FIL_CTRL(SR8015)	O		L	L	L	Filament Power control pin (for Porthole FLD)
125	PE7/IRQ7/AN105	ASO/DC_DET	I		I	I	I	Protection detect signal input pin (for ASO and DC) (A/D converter)
126	PE6/IRQ6/AN104	MIC_DET / H/P_DET	I		I	I	I	Headphone insert detect pin/Microphone insert detect pin (A/D converter)
127	VCC	VCC	-		-	-	-	Power supply pin
128	P70	ADC_RST	O		I	L	I	A/D convertor (AK5358) reset control pin
129	VSS	VSS	-		-	-	-	Ground pin
130	PE5/IRQ5/AN103	MAIN_POWER	O		L	L	L	Power supply control pin
131	PE4/AN102	CPU_POWER	O		L	L	L	CPU power supply control pin
132	PE3/AN101	AIOS4_WAKEUP	O		L	L	L	Same as NET5V_POWER, NET3.3V_POWER (This port use to control for Network Module standby mode in the future(Low:Deep Standby, High:normal))
133	PE2/RXD12/IRQ7-DS/AN100	AIOS4_STBY_STATUS	I	-	I	I	I	Not used (This port use to detect for Network Module standby status in the future (Low:normal, High:Deep Standby))
134	PE1/TXD12	GUI_WRITE	O		L	L	L	GUI flash rom writing control
135	PE0/SCK12	NET3.3V_POWER	O		L	L	L	Network power supply control (Net3.3V)
136	P64	NC	O		L	L	L	NC
137	P63	CEC_POWER	O	Pd	L	L	H	CEC standby power supply control (CEC5V, CEC3.3V, CEC1.8V) (When CEC standby mode3, set to Low)
138	P62	DV_POWER1	O		L	L	L	Digital video power supply (DV5V, DV3.3V) control pin
139	P61	DV_POWER2	O	Pd	L	L	L	Digital video power supply (DV1.8V) control pin
140	VSS	VSS	-		-	-	-	Ground pin
141	P60	DIR_DIN	O		L	L	L	DIR (PCM9211) control pin

Pin	Pin Name	Symbol	I/O	Pu/Pd	STBY	STOP	CEC STBY	Function
142	VCC	VCC	-	-	-	-	-	Power supply pin
143	PD7/IRQ7/AN107	DIR_CE	O		L	L	L	DIR (PCM9211) control pin
144	PG1	DIR_DOUT	I	DA3.3Pu	I	I	I	DIR (PCM9211) control pin
145	PD6/IRQ6/AN106	DIR_CLK	O		L	L	L	DIR (PCM9211) control pin
146	PG0	DIR_RST	O	Pd	L	L	L	DIR (PCM9211) control pin
147	PD5/IRQ5/AN113	TX_HAINT	I	Pd	I	I	I	HDMI Tx (MN864807) audio interrupt signal det
148	PD4/IRQ4/AN112	TX_TEMP	I	-	I	I	I	Temperature detection for HDMI Tx (MN864807) (A/D converter)
149	P97	DE_RST	O	Pd	L	L	L	Video decoder (ADV7180) reset control pin
150	PD3/IRQ3/AN111	TX_HINT	I	CEC3VPu	I	I	I	HDMI Tx (MN864807) interrupt signal input pin
151	VSS	VSS	-	-	-	-	-	Ground pin
152	P96	TX_RST	O	Pd	L	L	H	HDMI Tx (MN864807) reset control pin (When CEC standby mode3, set to reset)
153	VCC	VCC	-	-	-	-	-	Power supply pin
154	PD2/IRQ2/AN110	SW2_HINT	I	CEC3VPu	I	I	I	HDMI Rx/SW2 (MN864788) interrupt signal input pin
155	P95	SW2_RST	O	Pd	L	L	H	HDMI Rx/SW2 (MN864788) reset control pin (When CEC standby mode3, set to reset)
156	PD1/IRQ1/AN109	SW1_HINT	I	CEC3VPu	I	I	I	HDMI Rx/SW1 (MN864788) interrupt signal input pin
157	P94	SW1_RST	O	Pd	L	L	H	HDMI Rx/SW1 (MN864788) reset control pin (When CEC standby mode3, set to reset)
158	PD0/IRQ0/AN108	COMP_DET	I	SW3VPu	I	I	I	Component video signal detect pin
159	P93/AN117	TR_DET	I	SW3VPu	I	L	I	Protection detect signal input pin (for Power TR)
160	P92/RXD7/AN116	DA_POWER1	O	Pd	L	L	L	Digital audio power supply (DA3.3V,DA1.2V) control pin
161	P91/AN115	CURRENT_DET2_RSVD	I	Pd	I	L	I	Current level monitor pin (A/D converter) (Reserve)
162	VSS	VSS	-	-	-	-	-	Ground pin
163	P90/TXD7/AN114	TEMP_SENSOR	I	-	I	L	I	Temperature sensor input pin (for SRM)
164	VCC	VCC	-	-	-	-	-	Power supply pin
165	P47/IRQ15-DS/AN007	NC(RSV for Flagship)	I	Pd	I	I	I	NC (for flagship model identification)
166	P46/IRQ14-DS/AN006	CURRENT_DET	I	Pd	I	L	I	Current level monitor pin (A/D converter)
167	P45/IRQ13-DS/AN005	AMPSIGDET	I	Pd	I	L	I	Signal level monitor pin (A/D converter)
168	P44/IRQ12-DS/AN004	MODE	I		I	I	I	Region setting pin
169	P43/IRQ11-DS/AN003	KEY3	I	M3VPu	I	I	I	Key control signal input pin (When standby mode, set to interrupt)
170	P42/IRQ10-DS/AN002	KEY2	I	M3VPu	I	I	I	Key control signal input pin (When standby mode, set to interrupt)
171	P41/IRQ9-DS/AN001	KEY1	I	M3VPu	I	I	I	Key control signal input pin (When standby mode, set to interrupt)
172	VREFLO	VREFLO	-	-	-	-	-	Ground pin
173	P40	SEL_CLK	O		L	L	L	Audio selector control pin (NJU72750/72751)
174	VREFH0	VREFH0	-	-	-	-	-	Power supply pin
175	AVCC0	AVCC0	-	-	-	-	-	Power supply pin
176	P07/IRQ15	THERMAL_D	I	SW3VPu	I	L	I	Bridge Diode thermal detect pin (Reserve)

PCM9211 (DIGITAL : U7004)

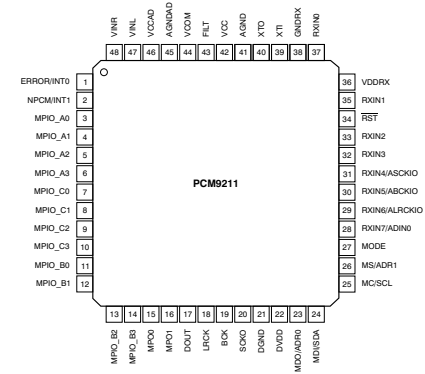

PIN Functions

PIN				DESCRIPTION
NO.	NAME	I/O	5-V TOLERANT	
1	ERROR/INT0	O	No	DIR Error detection output / Interrupt0 output
2	NPCM/INT1	O	No	DIR Non-PCM detection output / Interrupt1 output
3	MPIO_A0	I/O	Yes	Multipurpose I/O, Group A(1)
4	MPIO_A1	I/O	Yes	Multipurpose I/O, Group A(1)
5	MPIO_A2	I/O	Yes	Multipurpose I/O, Group A(1)
6	MPIO_A3	I/O	Yes	Multipurpose I/O, Group A(1)
7	MPIO_C0	I/O	Yes	Multipurpose I/O, Group C(1)
8	MPIO_C1	I/O	Yes	Multipurpose I/O, Group C(1)
9	MPIO_C2	I/O	Yes	Multipurpose I/O, Group C(1)
10	MPIO_C3	I/O	Yes	Multipurpose I/O, Group C(1)
11	MPIO_B0	I/O	Yes	Multipurpose I/O, Group B(1)
12	MPIO_B1	I/O	Yes	Multipurpose I/O, Group B(1)
13	MPIO_B2	I/O	Yes	Multipurpose I/O, Group B(1)
14	MPIO_B3	I/O	Yes	Multipurpose I/O, Group B(1)
15	MPO0	O	No	Multipurpose output 0
16	MPO1	O	No	Multipurpose output 1
17	DOUT	O	No	Main output port, serial digital audio data output
18	LRCK	O	No	Main output port, LR clock output
19	BCK	O	No	Main output port, Bit clock output
20	SCKO	O	No	Main output port, System clock output
21	DGND	-	-	Ground, for digital
22	DVDD	-	-	Power supply, 3.3 V (typ.), for digital
23	MDO/ADR0	I/O	Yes	Software control I/F, SPI data output / I2C slave address setting0(2)
24	MDI/SDA	I/O	Yes	Software control I/F, SPI data input / I2C data input/output(2)(3)
25	MC/SCL	I	Yes	Software control I/F, SPI clock input / I2C clock input(2)

PIN				DESCRIPTION
NO.	NAME	I/O	5-V TOLERANT	
26	MS/ADR1	I	Yes	Software control I/F, SPI chip select / I2C slave address setting ¹⁽²⁾
27	MODE	I	No	Control mode setting, (see the Serial Control Mode section, Control Mode Pin Setting)
28	RXIN7/ADIN0	I	Yes	Biphase signal, input 7 / AUXIN0, serial audio data input ²
29	RXIN6/ALRCKI0	I	Yes	Biphase signal, input 6 / AUXIN0, LR clock input ²
30	RXIN5/ABCKI0	I	Yes	Biphase signal, input 5 / AUXIN0, bit clock input ²
31	RXIN4/ASCKI0	I	Yes	Biphase signal, input 4 / AUXIN0, system clock input ²
32	RXIN3	I	Yes	Biphase signal, input 3 ²
33	RXIN2	I	Yes	Biphase signal, input 2 ²
34	RST	I	Yes	Reset Input, active low ² (4)
35	RXIN1	I	Yes	Biphase signal, input 1, built-in coaxial amplifier
36	VDDR _X	-	-	Power supply, 3.3 V (typ.), for RXIN0 and RXIN1.
37	RXIN0	I	Yes	Biphase signal, input 0, built-in coaxial amplifier
38	GNDR _X	-	-	Ground, for RXIN
39	XTI	I	No	Oscillation circuit input for crystal resonator or external XTI clock source input ⁵
40	XTO	O	No	Oscillation circuit output for crystal resonator
41	AGND	-	-	Ground, for PLL analog
42	VCC	-	-	Power supply, 3.3 V (typ.), for PLL analog
43	FILT	O	No	External PLL loop filter connection terminal; must connect recommended filter
44	VCOM	O	No	ADC common voltage output; must connect external decoupling capacitor
45	AGNDAD	-	-	Ground, for ADC analog
46	VCCAD	-	-	Power supply, 5.0 V (typ.), for ADC analog
47	VINL	I	No	ADC analog voltage input, left channel
48	VINR	I	No	ADC analog voltage input, right channel

- (1) Schmitt trigger input
- (2) Schmitt trigger input
- (3) Open-drain configuration in I2C mode
- (4) Onboard pull-down resistor (50 k Ω , typical)
- (5) CMOS Schmitt trigger input

PCM9211 BLOCK DIAGRAM

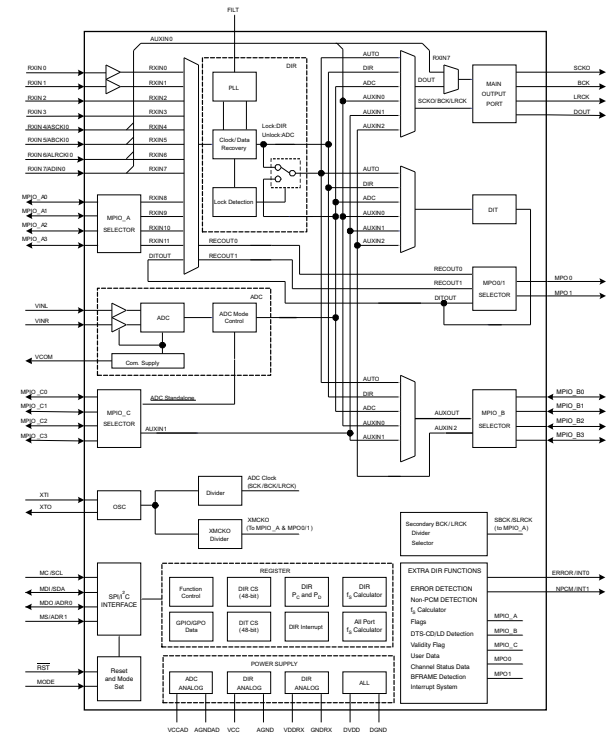

ADSP-21573KBCZ4D10 (DIGITAL : U0102)

ADSP-21573KBCZ4D6 (DIGITAL : U0252)

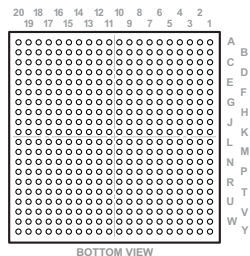

Terminal Function

Ball No.	Pin Name	Ball No.	Pin Name	Ball No.	Pin Name	Ball No.	Pin Name
A01	GND	C02	PC_13	E03	PE_03	G04	VDD_EXT
A02	PA_10	C03	GND	E04	PE_02	G05	VDD_INT
A03	PA_09	C04	PA_12	E05	GND	G06	GND
A04	PA_11	C05	PA_14	E06	PB_00	G07	GND
A05	PE_07	C06	PB_03	E07	VDD_EXT	G08	GND
A06	MLB0_CLKN	C07	PB_02	E08	VDD_EXT	G09	GND
A07	MLB0_CLKP	C08	PE_10	E09	VDD_EXT	G10	GND
A08	MLB0_SIGN	C09	PB_06	E10	VDD_EXT	G11	GND
A09	GND	C10	PB_05	E11	VDD_EXT	G12	GND
A10	SYS_XTALO	C11	SYS_HWRST	E12	VDD_EXT	G13	GND
A11	SYS_CLKINO	C12	USB0_ID	E13	VDD_USB	G14	GND
A12	GND	C13	USB0_CLKIN	E14	JTG_TCK	G15	GND
A13	SYS_XTAL1	C14	PB_12	E15	PE_15	G16	VDD_INT
A14	SYS_CLKIN1	C15	PB_13	E16	GND	G17	PB_15
A15	GND	C16	JTG_TDI	E17	VDD_EXT	G18	DAIO_PIN08
A16	USB0_DP	C17	PE_14	E18	PF_04	G19	DAIO_PIN10
A17	USB0_DM	C18	GND	E19	DAIO_PIN07	G20	DAIO_PIN09
A18	PF_03	C19	PF_08	E20	DAIO_PIN03	H01	PE_01
A19	PF_05	C20	PF_11	F01	PC_02	H02	PC_09
A20	GND	D01	PC_06	F02	PC_03	H03	PC_15
B01	PC_12	D02	PC_08	F03	PC_04	H04	VDD_EXT
B02	GND	D03	PE_04	F04	PE_06	H05	VDD_INT
B03	PA_13	D04	GND	F05	VDD_INT	H06	GND
B04	PA_15	D05	PE_08	F06	GND	H07	GND
B05	PB_01	D06	PE_11	F07	VDD_INT	H08	GND
B06	PB_04	D07	PE_09	F08	VDD_INT	H09	GND
B07	MLB0_DATN	D08	PB_08	F09	VDD_INT	H10	GND
B08	MLB0_DATP	D09	PB_07	F10	VDD_INT	H11	GND
B09	MLB0_SIGP	D10	PB_09	F11	VDD_INT	H12	GND
B10	JTG_TRST	D11	SYS_CLKOUT	F12	VDD_INT	H13	GND
B11	USB0_VBUS	D12	PB_11	F13	VDD_INT	H14	GND
B12	USB0_XTAL	D13	USB0_VBC	F14	VDD_INT	H15	GND
B13	PB_10	D14	PB_14	F15	GND	H16	VDD_INT
B14	JTG_TDO	D15	PE_13	F16	VDD_INT	H17	VDD_EXT
B15	JTG_TMS	D16	PE_12	F17	PF_02	H18	DAIO_PIN05
B16	PF_00	D17	GND	F18	PF_09	H19	DAIO_PIN14
B17	PF_01	D18	PF_10	F19	DAIO_PIN02	H20	DAIO_PIN11
B18	PF_06	D19	DAIO_PIN01	F20	DAIO_PIN06	J01	PE_00
B19	GND	D20	DAIO_PIN04	G01	PC_00	J02	PC_07
B20	PF_07	E01	PC_05	G02	PC_14	J03	PC_10
C01	PC_11	E02	PE_05	G03	PC_01	J04	VDD_EXT

Ball No.	Pin Name	Ball No.	Pin Name	Ball No.	Pin Name	Ball No.	Pin Name
J05	VDD_INT	L13	GND	P01	DMCO_VREF	T09	VDD_DMC
J06	GND	L14	GND	P02	DMCO_RZQ	T10	VDD_DMC
J07	GND	L15	GND	P03	DMCO_A09	T11	VDD_DMC
J08	GND	L16	VDD_INT	P04	DMCO_A10	T12	VDD_DMC
J09	GND	L17	VDD_EXT	P05	VDD_INT	T13	VDD_DMC
J10	GND	L18	DAIO_PIN17	P06	VDD_INT	T14	VDD_DMC
J11	GND	L20	DAIO_PIN20	P07	GND	T15	VDD_DMC
J12	GND	M01	DMCO_A14	P08	VDD_INT	T16	GND
J13	GND	M02	DMCO_A15	P09	VDD_INT	T17	VDD_DMC
J14	GND	M03	DMCO_A15	P10	VDD_INT	T18	DMCO_A02
J15	GND	M03	PD_09	P11	VDD_INT	T19	DMCO_A01
J16	VDD_INT	M04	VDD_EXT	P12	VDD_INT	T20	DMCO_RESET
J17	VDD_EXT	M05	VDD_INT	P13	VDD_INT	U01	DMCO_DQ15
J18	DAIO_PIN12	M06	GND	P14	GND	U02	DMCO_DQ14
J19	DAIO_PIN13	M07	GND	P15	VDD_INT	U03	TWI1_SDA
J20	DAIO_PIN16	M08	GND	P16	VDD_INT	U04	GND
K01	PD_14	M09	GND	P17	HADCO_VIN1	U05	TWI1_SCL
K02	PD_13	M10	GND	P18	HADCO_VIN0	U06	VDD_EXT
K03	PD_15	M11	GND	P19	HADCO_VREFP	U07	VDD_DMC
K04	VDD_EXT	M12	GND	P20	HADCO_VREFN	U08	VDD_DMC
K05	VDD_INT	M13	GND	R01	PD_06	U09	VDD_DMC
K06	GND	M14	GND	R02	PD_07	U10	VDD_DMC
K07	GND	M15	GND	R03	PD_08	U11	VDD_DMC
K08	GND	M16	VDD_INT	R04	VDD_INT	U12	VDD_DMC
K09	GND	M17	VDD_EXT	R05	VDD_INT	U13	VDD_DMC
K10	GND	M18	HADCO_VIN7	R06	GND	U14	VDD_DMC
K11	GND	M19	HADCO_VIN5	R07	VDD_INT	U15	DMCO_BA2
K12	GND	M20	HADCO_VIN6	R08	VDD_INT	U16	DMCO_WE
K13	GND	N01	DMCO_A11	R09	VDD_INT	U17	GND
K14	GND	N02	DMCO_A13	R10	VDD_INT	U18	DMCO_A06
K15	GND	N03	DMCO_A12	R11	VDD_INT	U19	DMCO_A03
K16	VDD_INT	N04	VDD_DMC	R12	VDD_INT	U20	DMCO_A00
K17	VDD_EXT	N05	VDD_INT	R13	VDD_INT	V01	TWI2_SDA
K18	DAIO_PIN15	N06	GND	R14	VDD_INT	V02	DMCO_DQ13
K19	DAIO_PIN19	N07	GND	R15	GND	V03	GND
K20	DAIO_PIN18	N08	GND	R16	VDD_INT	V04	PD_03
L01	PD_11	N09	GND	R17	VDD_INT	V05	PD_04
L02	PD_10	N10	GND	R18	DMCO_BA0	V06	PD_01
L03	PD_12	N11	GND	R19	HADCO_VIN2	V07	PA_08
L04	VDD_EXT	N12	GND	R20	VDD_HADC	V08	PA_05
L05	VDD_INT	N13	GND	T01	PD_05	V09	PA_03
L06	GND	N14	GND	T02	TWI0_SDA	V10	PA_02
L07	GND	N15	GND	T03	TWI0_SCL	V11	PA_01
L08	GND	N16	VDD_INT	T04	VDD_EXT	V12	PA_00
L09	GND	N17	VDD_EXT	T05	GND	V13	SYS_RESOUT
L10	GND	N18	HADCO_VIN4	T06	VDD_DMC	V14	SYS_FAULT
L11	GND	N19	HADCO_VIN3	T07	VDD_DMC	V15	DMCO_CAS
L12	GND	N20	GND	T08	VDD_DMC	V16	DMCO_RAS

Ball No.	Pin Name
V17	DMCO_BA1
V18	GND
V19	DMCO_A04
V20	DMCO_A05
W01	TWI2_SCL
W02	GND
W03	DMCO_DQ12
W04	DMCO_DQ11
W05	DMCO_DQ09
W06	PD_02
W07	PD_00
W08	PA_07
W09	PA_06
W10	PA_04
W11	DMCO_DQ05
W12	DMCO_DQ04
W13	DMCO_DQ03
W14	DMCO_DQ02
W15	SYS_FAULT
W16	DMCO_ODT
W17	DMCO_A08
W18	SYS_BMODE1
W19	GND
W20	DMCO_A07
Y01	GND
Y02	DMCO_UDQS
Y03	DMCO_UDQS
Y04	DMCO_DQ10
Y05	DMCO_DQ08
Y06	DMCO_UDM
Y07	DMCO_LDM
Y08	DMCO_CK
Y09	DMCO_CR
Y10	DMCO_DQ07
Y11	DMCO_DQ06
Y12	DMCO_LDQS
Y13	DMCO_LDQS
Y14	DMCO_DQ01
Y15	DMCO_DQ00
Y16	DMCO_CKE
Y17	DMCO_CS0
Y18	SYS_BMODE0
Y19	SYS_BMODE2
Y20	GND

Before Servicing This Unit

Electrical

Mechanical

Repair Information

Updating

No.	Pin Name	I/O	Function	PD State
15	CAD0_I2C	I	Chip Address 0 Pin in I2C Bus serial control mode	Hi-Z
	CSN	I	Chip Select Pin in 3-wire serial control mode	
	DIF	I	Audio Data Format Select in Parallel control mode. "L": 32-bit MSB, "H": 32-bit I2S	
16	PS	I	(I2C pin = "H") Control Mode Select Pin "L": I2C Bus serial control mode, "H": Parallel control mode.	Hi-Z
	CAD0_SPI	I	(I2C pin = "L") Chip Address 0 Pin in 3-wire serial control mode	
17	I2C	I	Control Mode Select Pin "L": 3-wire serial control mode "H": I2C Bus serial control mode or Parallel control mode.	Hi-Z
18	AOUTL1P	O	Lch Positive Analog Output 1 Pin	Hi-Z
19	AOUTL1N	O	Lch Negative Analog Output 1 Pin	Hi-Z
20	VREFL1	I	Negative Voltage Reference Input Pin, AVSS	Hi-Z
21	VREFH1	I	Positive Voltage Reference Input Pin, AVDD	Hi-Z
22	AOUTR1N	O	Rch Negative Analog Output 1 Pin	Hi-Z
23	AOUTR1P	O	Rch Positive Analog Output 1 Pin	Hi-Z
24	AOUTL2P	O	Lch Positive Analog Output 2 Pin	Hi-Z
25	AOUTL2N	O	Lch Negative Analog Output 2 Pin	Hi-Z
26	VREFL2	I	Negative Voltage Reference Input Pin, AVSS	Hi-Z
27	VREFH2	I	Positive Voltage Reference Input Pin, AVDD	Hi-Z
28	AOUTR2N	O	Rch Negative Analog Output 2 Pin	Hi-Z
29	AOUTR2P	O	Rch Positive Analog Output 2 Pin	Hi-Z
30	AVSS	-	Analog Ground Pin	—
31	AVDD	-	Analog Power Supply Pin, 3.0V-5.5V	—
32	AOUTL3P	O	Lch Positive Analog Output 3 Pin	Hi-Z
33	AOUTL3N	O	Lch Negative Analog Output 3 Pin	Hi-Z
34	VREFH3	I	Positive Voltage Reference Input Pin, AVDD	Hi-Z
35	VREFL3	I	Negative Voltage Reference Input Pin, AVSS	Hi-Z
36	AOUTR3N	O	Rch Negative Analog Output 3 Pin	Hi-Z
37	AOUTR3P	O	Rch Positive Analog Output 3Pin	Hi-Z
38	AOUTL4P	O	Lch Positive Analog Output 4 Pin	Hi-Z
39	AOUTL4N	O	Lch Negative Analog Output 4 Pin	Hi-Z
40	VREFH4	I	Positive Voltage Reference Input Pin, AVDD	Hi-Z
41	VREFL4	I	Negative Voltage Reference Input Pin, AVSS	Hi-Z
42	AOUTR4N	O	Rch Negative Analog Output 4 Pin	Hi-Z
43	AOUTR4P	O	Rch Positive Analog Output 4 Pin	Hi-Z
44	LDOE	I	Internal LDO Enable Pin. "L": Disable, "H": Enable	Hi-Z
45	TVDD	-	Digital Power Supply Pin, 3.0V-3.6V	—
46	DVSS	-	Digital Ground Pin	—
47	VDD18	O	LDO Output Pin (LDOE pin = "H") This pin should be connected to DVSS with 1.0μF.	(Note 4)
		I	1.8V Power Input Pin (LDOE pin = "L")	
48	PDN	I	Power-Down & Reset Pin When this pin is "L", the AK4458 is powered-down and the control registers are reset to default state.	Hi-Z

Note 2. All input pins except internal pull-up/down pins should not be left floating.

Note 3. PCM mode and DSD mode are controlled by registers. Daisy Chain mode is controlled by both registers and pins.

Note 4. This pin outputs DVSS when the LDOE pin = "H" and Hi-z when the LDOE pin = "L".

FUNCTIONAL BLOCK DIAGRAM

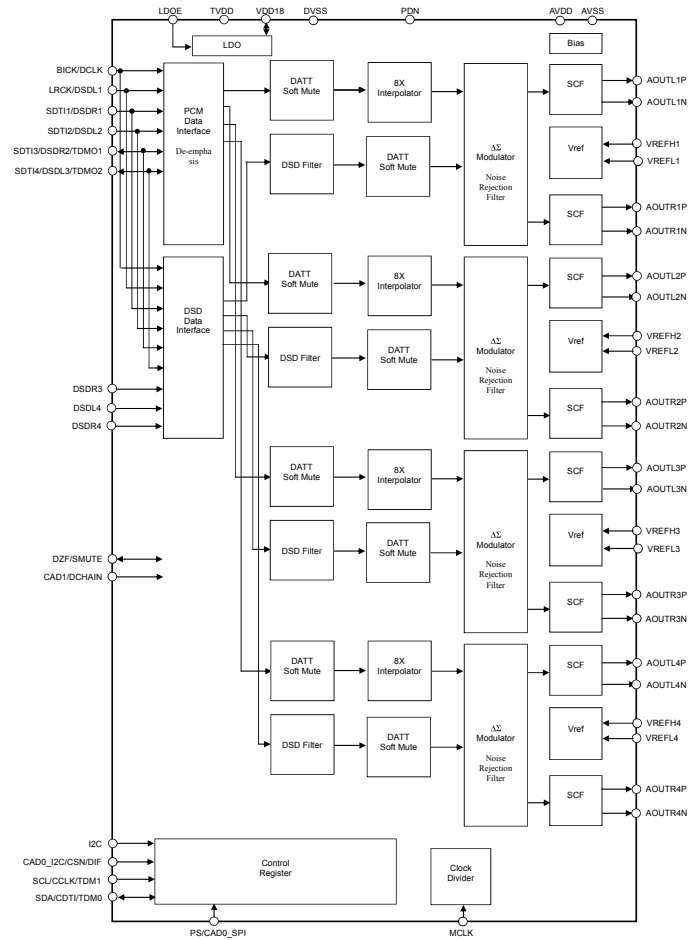

AK5358BET (DAC : U401)

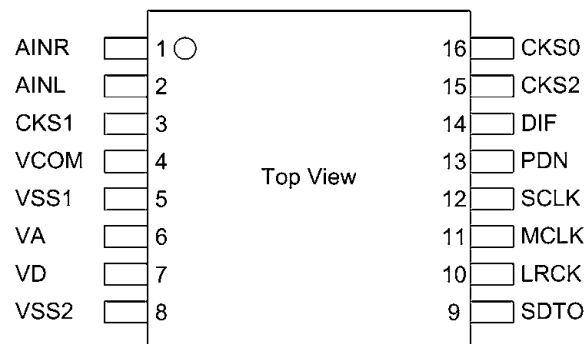

AK5358BET Pin Function

No.	Pin Name	I/O	Function
1	AINR	I	Rch Analog Input Pin
2	AINL	I	Lch Analog Input Pin
3	CKS1	I	Mode Select 1 Pin
4	VCOM	O	Common Voltage Output Pin, VA/2 Bias voltage of ADC input.
5	VSS1	-	Ground Pin
6	VA	-	Analog Power Supply Pin, 4.5 ~ 5.5V
7	VD	-	Digital Power Supply Pin, 2.7 ~ 5.5V
8	VSS2	-	Ground Pin
9	SDTO	O	Audio Serial Data Output Pin “L” Output at Power-down mode.
10	LRCK	I/O	Output Channel Clock Pin “L” Output in Master Mode at Power-down mode.
11	MCLK	I	Master Clock Input Pin
12	SCLK	I/O	Audio Serial Data Clock Pin “L” Output in Master Mode at Power-down mode.
13	PDN	I	Power Down Mode & Reset Pin “H”: Power up, “L”: Power down & Reset
14	DIF	I	Audio Interface Format Pin “H”: 24bit I ² S Compatible, “L”: 24bit MSB justified
15	CKS2	I	Mode Select 2 Pin
16	CKS0	I	Mode Select 0 Pin

PCM5100 (DAC : U402, 403, U404)

PCM510X (top view)

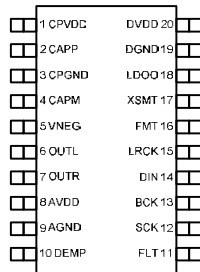

Table 2. TERMINAL FUNCTIONS, PCM510x

TERMINAL NAME	NO.	I/O	DESCRIPTION
CPVDD	1	-	Charge pump power supply, 3.3V
CAPP	2	O	Charge pump flying capacitor terminal for positive rail
CPGND	3	-	Charge pump ground
CAPM	4	O	Charge pump flying capacitor terminal for negative rail
VNEG	5	O	Negative charge pump rail terminal for decoupling, -3.3V
OUTL	6	O	Analog output from DAC left channel
OUTR	7	O	Analog output from DAC right channel
AVDD	8	-	Analog power supply, 3.3V
AGND	9	-	Analog ground
DEMP	10	I	De-emphasis control for 44.1kHz sampling rate ⁽¹⁾ : Off (Low) / On (High)
FLT	11	I	Filter select : Normal latency (Low) / Low latency (High)
SCK	12	I	System clock input
BCK	13	I	Audio data bit clock input
DIN	14	I	Audio data input
LRCK	15	I	Audio data word clock input
FMT	16	I	Audio format selection : I ² S (Low) / Left justified (High)
XSMT	17	I	Soft mute control : Soft mute (Low) / soft un-mute (High)
LDOO	18	-	Internal logic supply rail terminal for decoupling
DGND	19	-	Digital ground
DVDD	20	-	Digital power supply, 3.3V

PCM5100 Block Diagram

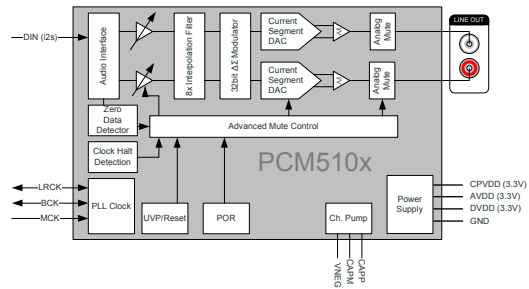
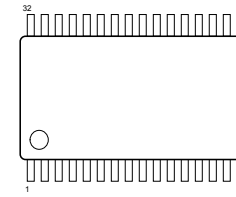

Figure 1. PCM510x Functional Block Diagram

NJU72343 (AUDIO/VIDEO : U104, U105)



No.	Symbol	Function	No.	Symbol	Function
1	AREF	Analog reference potential	17	DATA	IC control data input
2	ADR	Address selection	18	CLOCK	IC control clock input
3	InA2	Ach input2	19	VDDOUT	Digital power supply output
4	InB2	Bch input2	20	AREF	Analog reference potential
5	InA1	Ach input1	21	OutH	Hch output
6	InB1	Bch input1	22	OutG	Gch output
7	InC	Cch input	23	OutF	Fch output
8	InD	Dch input	24	OutE	Ech output
9	InE	Ech input	25	OutD	Dch output
10	InF	Fch input	26	OutC	Cch output
11	InG1	Gch input1	27	OutB	Bch output
12	InH1	Hch input1	28	OutA	Ach output
13	InG2	Cch input2	29	AREF	Analog reference potential
14	InH2	Dch input2	30	V-	Power supply(-)
15	MUTE	External mute control	31	AREF	Analog reference potential
16	REF	Digital reference potential	32	V+	Power supply(+)

NJU72750 (AUDIO/VIDEO : U101, U102, U103)

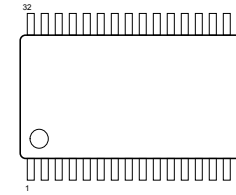

No.	Symbol	Function	No.	Symbol	Function
1	V+	Power supply(+)	17	DATA	IC control data input
2	InA1	Ach input1	18	CLOCK	IC control clock input
3	InB1	Bch input1	19	NC	-
4	InA2	Ach input2	20	NC	-
5	InB2	Bch input2	21	OutB3	Bch output3
6	InA3	Ach input3	22	OutA3	Ach output3
7	InB3	Bch input3	23	REF_B	Bch reference potential
8	InA4	Ach input4	24	OutB2	Bch output2
9	InB4	Bch input4	25	OutA2	Ach output2
10	InA5	Ach input5	26	REF_A	Ach reference potential
11	InB5	Bch input5	27	OutB1	Bch output1
12	InA6	Ach input6	28	OutA1	Ach output1
13	InB6	Bch input6	29	NC	-
14	InA7	Ach input7	30	ADR0	Address selection pin 0
15	InB7	Bch input7	31	ADR1	Address selection pin 1
16	REF	BIAS reference potential	32	V-	Power supply(-)

NJU72751 (AUDIO/VIDEO : U107, U108, U110, U111, U112)

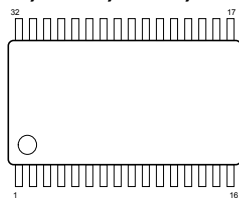

No.	Symbol	Function	No.	Symbol	Function
1	V+	Power supply(+)	17	CLOCK	IC control clock input
2	ADR0	Address selection pin 0	18	NC	-
3	InA1	Ach input1	19	OutB4	Bch output4
4	InB1	Bch input1	20	OutA4	Ach output4
5	NC	-	21	NC	-
6	InA2	Ach input2	22	OutB3	Bch output3
7	InB2	Bch input2	23	OutA3	Ach output3
8	NC	-	24	REF_B	Bch reference potential
9	NC	-	25	REF_A	Ach reference potential
10	InA3	Ach input3	26	OutB2	Bch output2
11	InB3	Bch input3	27	OutA2	Ach output2
12	NC	-	28	NC	-
13	InA4	Ach input4	29	OutB1	Bch output1
14	InB4	Bch input4	30	OutA1	Ach output1
15	REF	BIAS reference potential	31	ADR1	Address selection pin 1
16	DATA	IC control data input	32	V-	Power supply(-)

2. FL DISPLAY

FLD (17-BT-40GINK) (FRONT : Z6402)

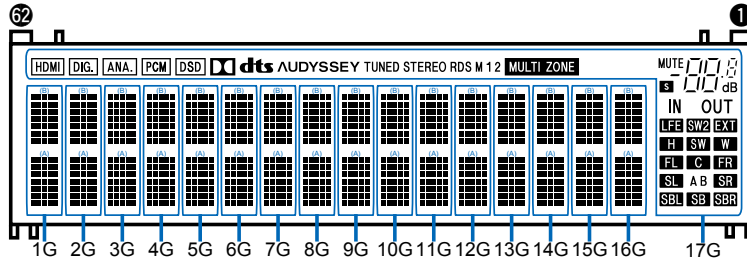

PIN CONNECTION

CONNECTION	PIN NO.
F2	62
NX	61
NP	60
NP	59
LGND	58
PGND	57
VH	56
VDD	55
OSC	54
RESET	53
CS	52
CP	51

CONNECTION	PIN NO.
DA	50
TSA	49
Q17G	48
Q17G	47
17G	46
NX	45
NX	44
NX	43
NX	42
NX	41
NX	40
NX	39
NX	38
NX	37
NX	36
NX	35
NX	34
NX	33
NX	32
NX	31
NX	30
NX	29
NX	28
NX	27
NX	26
NX	25
NX	24
NX	23
NX	22
NX	21
NX	20
NX	19
NX	18
NX	17
NX	16
NX	15
NX	14
NX	13
NX	12
NX	11
NX	10
NX	9
NX	8
NX	7
NX	6
NX	5
NP	4
NP	3
NP	2
F1	1

NOTE

- 1) F1, F2 ----Filament
- 2) NP -----No pin
- 3) DL -----Datum Line
- 4) NX -----No extend pin
- 5) 17G ----Grid
- 6) Q17G ----Driver Output Port.
- 7) LGND ----Logic GND pin
- 8) PGND ----Power GND pin
- 9) VH -----High Voltage Supply pin
- 10) VDD -----Logic Voltage Supply pin
- 11) OSC ----Pin for self-oscillation
- 12) RESET --Reset Input
- 13) CS -----Chip Select Input pin
- 14) CP ----Shift Register Clock
- 15) DA ----Serial Data Input
- 16) TSA, B --Test pin
- 17) Solder composition is Sn-3Ag-0.5Cu.
- 18) Field of vision is a minimum of 21.8° from the lower side.

PATTERN DETAIL

1G-16G				
1-1	2-1	3-1	4-1	5-1
1-2	2-2	3-2	4-2	5-2
1-3	2-3	3-3	4-3	5-3
1-4	2-4	3-4	4-4	5-4
1-5	2-5	3-5	4-5	5-5
1-6	2-6	3-6	4-6	5-6
1-7	2-7	3-7	4-7	5-7

ANODE CONNECTION

	1G-16G	17G
D0A	1-1A	-
D1A	2-1A	-
D2A	3-1A	-
D3A	4-1A	-
D4A	5-1A	-
D5A	1-2A	-
D6A	2-2A	-
D7A	3-2A	-
D8A	4-2A	-
D9A	5-2A	-
D10A	1-3A	dB
D11A	2-3A	Dp
D12A	3-3A	3d
D13A	4-3A	3e
D14A	5-3A	3c
D15A	1-4A	3g
D16A	2-4A	3f
D17A	3-4A	3b
D18A	4-4A	3a
D19A	5-4A	2d
D20A	1-5A	2e
D21A	2-5A	2c
D22A	3-5A	2g
D23A	4-5A	2f
D24A	5-5A	2b
D25A	1-6A	2a
D26A	2-6A	1d
D27A	3-6A	1e
D28A	4-6A	1c
D29A	5-6A	1g
D30A	1-7A	1f
D31A	2-7A	1b
D32A	3-7A	1a
D33A	4-7A	S1
D34A	5-7A	S

	1G-16G	17G
D0B	1-1B	HDMI
D1B	2-1B	DIG
D2B	3-1B	ANA
D3B	4-1B	PCM
D4B	5-1B	DSD
D5B	1-2B	D
D6B	2-2B	dts
D7B	3-2B	AUDYSSEY
D8B	4-2B	TUNED
D9B	5-2B	STEREO
D10B	1-3B	RDS
D11B	2-3B	M
D12B	3-3B	1
D13B	4-3B	2
D14B	5-3B	MULTI ZONE
D15B	1-4B	INDEXING
D16B	2-4B	MUTE
D17B	3-4B	IN
D18B	4-4B	OUT
D19B	5-4B	LFE
D20B	1-5B	SW2
D21B	2-5B	EXT
D22B	3-5B	H
D23B	4-5B	SW
D24B	5-5B	W
D25B	1-6B	FL
D26B	2-6B	C
D27B	3-6B	FR
D28B	4-6B	SL
D29B	5-6B	A
D30B	1-7B	B
D31B	2-7B	SR
D32B	3-7B	SBL
D33B	4-7B	SB
D34B	5-7B	SBR

3. Remote Code Table

FORMAT: SHARP

FORMAT: SHARP/DATA CONSTRUCTION 15bits C14 0 C15 0=NOT INVERTED, 1=INVERTED/REMOTE ID : 1
SYSTEM ADDRESS(C1 ~ C5) : 0 1 0 0 0 , EXTENSION BIT(C12,C13) : 1 1

No.	Data (C6 ~ C11)	Key Name	No.	Data (C6 ~ C11)	Key Name
RCSHP0230000	0 0 0 0 0		RCSHP0230016	0 0 0 0 1	FR LEVEL DOWN
RCSHP0230001	1 0 0 0 0	POWER	RCSHP0230017	1 0 0 0 1	
RCSHP0230002	0 1 0 0 0	FL LEVEL UP	RCSHP0230018	0 1 0 0 1	
RCSHP0230003	1 1 0 0 0	PHONO	RCSHP0230019	1 1 0 0 1	
RCSHP0230004	0 0 1 0 0	CD	RCSHP0230020	0 0 1 0 1	
RCSHP0230005	1 0 1 0 0	TUNER	RCSHP0230021	1 0 1 0 1	
RCSHP0230006	0 1 1 0 0		RCSHP0230022	0 1 1 0 1	SR LEVEL UP
RCSHP0230007	1 1 1 0 0	FL LEVEL DOWN	RCSHP0230023	1 1 1 0 1	SR LEVEL DOWN
RCSHP0230008	0 0 1 0 0	CBL/SAT	RCSHP0230024	0 0 1 0 1	VIDEO SELECT
RCSHP0230009	1 0 0 1 0	TV AUDIO	RCSHP0230025	1 0 0 1 0	
RCSHP0230010	0 1 0 1 0	Blu-ray	RCSHP0230026	0 1 0 1 0	
RCSHP0230011	1 1 0 1 0	FR LEVEL UP	RCSHP0230027	1 1 0 1 0	
RCSHP0230012	0 0 1 1 0	AUX	RCSHP0230028	0 0 1 1 0	INPUT MODE ANALOG
RCSHP0230013	1 0 1 1 0	GAME	RCSHP0230029	1 0 1 1 0	CURSOR RIGHT
RCSHP0230014	0 1 1 1 0	MEDIA PLAYER	RCSHP0230030	0 1 1 1 0	STATUS
RCSHP0230015	1 1 1 1 0		RCSHP0230031	1 1 1 1 0	INFO

No.	Data (C6 ~ C11)	Key Name	No.	Data (C6 ~ C11)	Key Name
RCSHP0230032	0 0 0 0 1	ENTER	RCSHP0230048	0 0 0 1 1	MUTING
RCSHP0230033	1 0 0 0 1	POWER ON	RCSHP0230049	1 0 0 1 1	MASTER VOLUME UP
RCSHP0230034	0 1 0 0 1	POWER OFF	RCSHP0230050	0 1 0 1 1	MASTER VOLUME DOWN
RCSHP0230035	1 1 0 0 1	DVD	RCSHP0230051	1 1 0 1 1	SL LEVEL UP
RCSHP0230036	0 0 1 0 1	STANDARD(DOLBY/DTS SURR.)	RCSHP0230052	0 0 1 0 1	SL LEVEL DOWN
RCSHP0230037	1 0 1 0 1	SW LEVEL DOWN	RCSHP0230053	1 0 1 0 1	CENTER LEVEL UP
RCSHP0230038	0 1 1 0 1	DSP SIMULATION	RCSHP0230054	0 1 1 0 1	CENTER LEVEL DOWN
RCSHP0230039	1 1 1 0 1	SB/SBL LEVEL UP	RCSHP0230055	1 1 1 0 1	SBR LEVEL UP
RCSHP0230040	0 0 0 1 0		RCSHP0230056	0 0 0 1 0	SBR LEVEL DOWN
RCSHP0230041	1 0 0 1 0		RCSHP0230057	1 0 0 1 0	STONE CONTROL OFF
RCSHP0230042	0 1 0 1 0		RCSHP0230058	0 1 0 1 0	STONE CONTROL ON
RCSHP0230043	1 1 0 1 0	SB/SBL LEVEL DOWN	RCSHP0230059	1 1 0 1 0	
RCSHP0230044	0 0 1 1 0	SW LEVEL UP	RCSHP0230060	0 0 1 1 0	
RCSHP0230045	1 0 1 1 0	FRONT SPEAKER	RCSHP0230061	1 0 1 1 0	
RCSHP0230046	0 1 1 1 0	SP-A_FRONT	RCSHP0230062	0 1 1 1 0	
RCSHP0230047	1 1 1 1 0	SP-B_FRONT	RCSHP0230063	1 1 1 1 0	

FORMAT: SHARP/DATA CONSTRUCTION 15bits C14 0 C15 0=NOT INVERTED, 1=INVERTED/REMOTE ID : 1
SYSTEM ADDRESS(C1 ~ C5) : 0 0 1 1 0 , EXTENSION BIT (C12,C13) : 0 1

No.	Data (C6 ~ C11)	Key Name	No.	Data (C6 ~ C11)	Key Name
RCSHP0C20000	0 0 0 0 0	ALL BASS DOWN	RCSHP0C20016	0 0 0 0 1	ZONE2 CD
RCSHP0C20001	1 0 0 0 0		RCSHP0C20017	1 0 0 0 1	ZONE2 TUNER
RCSHP0C20002	0 1 0 0 0	SURROUND BACK	RCSHP0C20018	0 1 0 0 0	ZONE2 Blu-ray
RCSHP0C20003	1 1 0 0 0	MASTER VOL. PRESET1(0dB)	RCSHP0C20019	1 1 0 0 0	ZONE2 AUX
RCSHP0C20004	0 0 1 0 0		RCSHP0C20020	0 0 1 0 0	ZONE2 GAME
RCSHP0C20005	1 0 1 0 0	MASTER VOL. PRESET2(-20dB)	RCSHP0C20021	1 0 1 0 0	
RCSHP0C20006	0 1 1 0 0	MASTER VOL. PRESET3(-40dB)	RCSHP0C20022	0 1 1 0 0	ZONE2 PRESET UP
RCSHP0C20007	1 1 1 0 0	ZONE2 VOL. PRESET1(0dB)	RCSHP0C20023	1 1 1 0 0	ZONE2 PRESET DOWN
RCSHP0C20008	0 0 1 0 0	ZONE2 VOL. PRESET2(-20dB)	RCSHP0C20024	0 0 1 0 0	
RCSHP0C20009	1 0 0 1 0	ZONE2 VOL. PRESET3(-40dB)	RCSHP0C20025	1 0 0 1 0	ZONE2 MEDIA PLAYER
RCSHP0C20010	0 1 0 1 0	ZONE2 CBL/SAT	RCSHP0C20026	0 1 0 1 0	
RCSHP0C20011	1 1 0 1 0		RCSHP0C20027	1 1 0 1 0	ZONE2 TV AUDIO
RCSHP0C20012	0 0 1 1 0	ZONE3 VOL. PRESET1(0dB)	RCSHP0C20028	0 0 1 1 0	
RCSHP0C20013	1 0 1 1 0	ZONE2 VOLUME UP	RCSHP0C20029	1 0 1 1 0	STEREO
RCSHP0C20014	0 1 1 1 0	ZONE2 VOLUME DOWN	RCSHP0C20030	0 1 1 1 0	DIRECT
RCSHP0C20015	1 1 1 1 0	ZONE2 PHONO	RCSHP0C20031	1 1 1 1 0	ZONE3 VOL. PRESET2(0dB)

No.	Data (C6 ~ C11)	Key Name	No.	Data (C6 ~ C11)	Key Name
RCSHP0C20032	0 0 0 0 1	SETUP MENU	RCSHP0C20048	0 0 0 1 1	
RCSHP0C20033	1 0 0 0 1		RCSHP0C20049	1 0 0 1 1	
RCSHP0C20034	0 1 0 0 1	ZONE3 VOL. PRESET2(0dB)	RCSHP0C20050	0 1 0 0 1	
RCSHP0C20035	1 1 0 0 1	CURSOR UP	RCSHP0C20051	1 1 0 0 1	
RCSHP0C20036	0 0 1 0 1	CURSOR DOWN	RCSHP0C20052	0 0 1 0 1	
RCSHP0C20037	1 0 1 0 1		RCSHP0C20053	1 0 1 0 1	
RCSHP0C20038	0 1 1 0 1		RCSHP0C20054	0 1 1 0 1	INPUT MODE
RCSHP0C20039	1 1 1 0 1		RCSHP0C20055	1 1 1 0 1	ALL TREBLE UP
RCSHP0C20040	0 0 0 1 0	MULTI CH STEREO	RCSHP0C20056	0 0 0 1 0	ALL TREBLE DOWN
RCSHP0C20041	1 0 0 1 0		RCSHP0C20057	1 0 0 1 0	
RCSHP0C20042	0 1 0 1 0		RCSHP0C20058	0 1 0 1 0	
RCSHP0C20043	1 1 0 1 0		RCSHP0C20059	1 1 0 1 0	
RCSHP0C20044	0 0 1 1 0		RCSHP0C20060	0 0 1 1 0	
RCSHP0C20045	1 0 1 1 0		RCSHP0C20061	1 0 1 1 0	
RCSHP0C20046	0 1 1 1 0		RCSHP0C20062	0 1 1 1 0	ZONE2 DVD
RCSHP0C20047	1 1 1 1 0	CH LEVEL	RCSHP0C20063	1 1 1 1 0	ALL BASS UP

FORMAT: SHARP/DATA CONSTRUCTION 15bits C14 0 C15 0=NOT INVERTED, 1=INVERTED/REMOTE ID : 1
SYSTEM ADDRESS(C1 ~ C5) : 0 0 1 1 0 , EXTENSION BIT (C12,C13) : 1 0

No.	Data (C6 ~ C11)	Key Name	No.	Data (C6 ~ C11)	Key Name
RCSHP0C10032	0 0 0 0 1		RCSHP0C10048	0 0 0 0 1	
RCSHP0C10033	1 0 0 0 1		RCSHP0C10049	1 0 0 0 1	
RCSHP0C10034	0 1 0 0 1		RCSHP0C10050	0 1 0 0 1	
RCSHP0C10035	1 1 0 0 1		RCSHP0C10051	1 1 0 0 1	
RCSHP0C10036	0 0 1 0 1		RCSHP0C10052	0 0 1 0 1	
RCSHP0C10037	1 0 1 0 1		RCSHP0C10053	1 0 1 0 1	
RCSHP0C10038	0 1 1 0 1		RCSHP0C10054	0 1 1 0 1	
RCSHP0C10039	1 1 1 0 1		RCSHP0C10055	1 1 1 0 1	
RCSHP0C10040	0 0 0 1 0		RCSHP0C10056	0 0 0 1 0	
RCSHP0C10041	1 0 0 1 0		RCSHP0C10057	1 0 0 1 0	
RCSHP0C10042	0 1 0 1 0		RCSHP0C10058	0 1 0 1 0	
RCSHP0C10043	1 1 0 1 0		RCSHP0C10059	1 1 0 1 0	
RCSHP0C10044	0 0 1 1 0		RCSHP0C10060	0 0 1 1 0	
RCSHP0C10045	1 0 1 1 0		RCSHP0C10061	1 0 1 1 0	
RCSHP0C10046	0 1 1 1 0		RCSHP0C10062	0 1 1 1 0	
RCSHP0C10047	1 1 1 1 0		RCSHP0C10063	1 1 1 1 0	CURSOR LEFT

FORMAT: SHARP/DATA CONSTRUCTION 15bits C14 0 C15 0=NOT INVERTED, 1=INVERTED/REMOTE ID : 1
SYSTEM ADDRESS(C1 ~ C5) : 0 0 1 1 0 , EXTENSION BIT (C12,C13) : 1 1

No.	Data (C6 ~ C11)	Key Name	No.	Data (C6 ~ C11)	Key Name
RCSHP0C30000	0 0 0 0 0		RCSHP0C30016	0 0 0 1 0	
RCSHP0C30001	1 0 0 0 0	1 ※ NA only	RCSHP0C30017	1 0 0 1 0	
RCSHP0C30002	0 1 0 0 0	2 ※ NA only	RCSHP0C30018	0 1 0 1 0	DIRECT SEARCH ※ NA only
RCSHP0C30003	1 1 0 0 0	3 ※ NA only	RCSHP0C30019	1 1 0 1 0	
RCSHP0C30004	0 0 1 0 0	4 ※ NA only	RCSHP0C30020	0 0 1 0 0	PTY ※ EU only
RCSHP0C30005	1 0 1 0 0	5 ※ NA only	RCSHP0C30021	1 0 1 1 0	TUNER PRESET DOWN ※ NA only
RCSHP0C30006	0 1 1 0 0	6 ※ NA only	RCSHP0C30022	0 1 1 0 0	TUNER PRESET UP ※ NA only
RCSHP0C30007	1 1 1 0 0	7 ※ NA only	RCSHP0C30023	1 1 1 0 0	TUNER BAND ※ NA only
RCSHP0C30008	0 0 0 1 0	8 ※ NA only	RCSHP0C30024	0 0 0 1 0	TUNER TUNING MODE ※ NA only
RCSHP0C30009	1 0 0 1 0	9 ※ NA only	RCSHP0C30025	1 0 0 1 0	TUNER TUNING UP ※ NA only
RCSHP0C30010	0 1 0 1 0	0 ※ NA only	RCSHP0C30026	0 1 0 1 0	TUNER TUNING DOWN ※ NA only
RCSHP0C30011	1 1 0 1 0		RCSHP0C30027	1 1 0 1 0	
RCSHP0C30012	0 0 1 1 0	TUNER MEMORY ※ NA only	RCSHP0C30028	0 0 1 1 0	
RCSHP0C30013	1 0 1 1 0		RCSHP0C30029	1 0 1 1 0	
RCSHP0C30014	0 1 1 1 0	RT ※ EU only	RCSHP0C30030	0 1 1 1 0	
RCSHP0C30015	1 1 1 1 0		RCSHP0C30031	1 1 1 1 0	DIMMER

FORMAT: SHARP/DATA CONSTRUCTION 15bits C14 0 C15 0=NOT INVERTED, 1=INVERTED /REMOTE ID : 1
SYSTEM ADDRESS (C1 ~ C5) : 0 1 0 0 0 , EXTENSION BIT (C12,C13) : 1 0

No.	Data (C6 ~ C11)	Key Name	No.	Data (C6 ~ C11)	Key Name
RCSHP0210000	0 0 0 0 0		RCSHP0210016	0 0 0 0 1	
RCSHP0210001	1 0 0 0 0		RCSHP0210017	1 0 0 0 1	
RCSHP0210002	0 1 0 0 0		RCSHP0210018	0 1 0 0 0	ZONE3 TV AUDIO
RCSHP0210003	1 1 0 0 0		RCSHP0210019	1 1 0 0 0	ZONE3 CBL/SAT
RCSHP0210004	0 0 1 0 0		RCSHP0210020	0 0 1 0 0	ZONE3 GAME
RCSHP0210005	1 0 1 0 0		RCSHP0210021	1 0 1 0 0	ZONE3 MEDIAPLAYER
RCSHP0210006	0 1 1 0 0		RCSHP0210022	0 1 1 0 0	
RCSHP0210007	1 1 1 0 0		RCSHP0210023	1 1 1 0 0	ZONE3 AUX
RCSHP0210008	0 0 1 0 0	ZONE3 TUNER	RCSHP0210024	0 0 1 0 0	
RCSHP0210009	1 0 0 1 0	ZONE3 PHONO	RCSHP0210025	1 0 0 1 0	
RCSHP0210010	0 1 0 1 0	ZONE3 CD	RCSHP0210026	0 1 0 1 0	
RCSHP0210011	1 1 0 1 0		RCSHP0210027	1 1 0 1 0	
RCSHP0210012	0 0 1 1 0		RCSHP0210028	0 0 1 1 0	
RCSHP0210013	1 0 1 1 0		RCSHP0210029	1 0 1 1 0	ZONE2 ON/OFF
RCSHP0210014	0 1 1 1 0	ZONE3 DVD	RCSHP0210030	0 1 1 1 0	
RCSHP0210015	1 1 1 1 0	ZONE3 Blu-ray	RCSHP0210031	1 1 1 1 0	

No.	Data (C6 ~ C11)	Key Name	No.	Data (C6 ~ C11)	Key Name
RCSHP0210032	0 0 0 0 1		RCSHP0210048	0 0 0 0 1	
RCSHP0210033	1 0 0 0 1		RCSHP0210049	1 0 0 0 1	
RCSHP0210034	0 1 0 0 1		RCSHP0210050	0 1 0 0 1	
RCSHP0210035	1 1 0 0 1		RCSHP0210051	1 1 0 0 1	
RCSHP0210036	0 0 1 0 1		RCSHP0210052	0 0 1 0 1	
RCSHP0210037	1 0 1 0 1	ZONE3 VOLUME DOWN	RCSHP0210053	1 0 1 0 1	
RCSHP0210038	0 1 1 0 1	ZONE3 VOLUME UP	RCSHP0210054	0 1 1 0 1	
RCSHP0210039	1 1 1 0 1		RCSHP0210055	1 1 1 0 1	
RCSHP0210040	0 0 0 1 0		RCSHP0210056	0 0 0 1 0	
RCSHP0210041	1 0 0 1 0		RCSHP0210057	1 0 0 1 0	MAIN ZONE ON
RCSHP0210042	0 1 0 1 0	PURE DIRECT	RCSHP0210058	0 1 0 1 0	MAIN ZONE OFF
RCSHP0210043	1 1 0 1 0		RCSHP0210059	1 1 0 1 0	ZONE2 ON
RCSHP0210044	0 0 1 1 0		RCSHP0210060	0 0 1 1 0	ZONE2 OFF
RCSHP0210045	1 0 1 1 0		RCSHP0210061	1 0 1 1 0	ZONE3 ON
RCSHP0210046	0 1 1 1 0		RCSHP0210062	0 1 1 1 0	ZONE3 OFF
RCSHP0210047	1 1 1 1 0		RCSHP0210063	1 1 1 1 0	

ZONE2

REMOTE ID SET: 1

DENON CODE								Parity				GENRE1				GENRE2											
1	2	3	4	5	6	7	8	9	10	11	12	13	14	15	16	17	18	19	20	21	22	23	24	25	26	27	28
0	0	1	0	1	0	1	0	0	1	0	0	1	1	0	0	0	0	0	0	0	0	1	0	1	1	0	0

REMOTE ID SET: 2-4

DENON CODE								Parity				GENRE1				GENRE2											
1	2	3	4	5	6	7	8	9	10	11	12	13	14	15	16	17	18	19	20	21	22	23	24	25	26	27	28
0	0	1	0	1	0	1	0	0	1	0	0	1	1	0	0	0	0	0	0	0	0	1	0	1	1	0	0

No.	Data								ID								Key Name				
	29	30	31	32	33	34	35	36	37	38	39	40	41	42	43	44		45	46	47	48
RCKSK0430005	1	0	1	0	0	0	0	0	0	0	*	*	*	*	*	*	*	*	*	*	ZONE2 POWER ON/OFF
RCKSK0430006	0	1	1	0	0	0	0	0	0	0	*	*	*	*	*	*	*	*	*	*	ZONE2 POWER ON
RCKSK0430007	1	1	1	0	0	0	0	0	0	0	*	*	*	*	*	*	*	*	*	*	ZONE2 POWER OFF
RCKSK0430016	0	0	0	0	1	0	0	0	0	0	*	*	*	*	*	*	*	*	*	*	ZONE2 KEY1
RCKSK0430017	1	0	0	0	1	0	0	0	0	0	*	*	*	*	*	*	*	*	*	*	ZONE2 KEY2
RCKSK0430018	0	1	0	0	1	0	0	0	0	0	*	*	*	*	*	*	*	*	*	*	ZONE2 KEY3
RCKSK0430019	1	1	0	0	1	0	0	0	0	0	*	*	*	*	*	*	*	*	*	*	ZONE2 KEY4
RCKSK0430020	0	0	1	0	1	0	0	0	0	0	*	*	*	*	*	*	*	*	*	*	ZONE2 KEY5
RCKSK0430021	1	0	1	0	1	0	0	0	0	0	*	*	*	*	*	*	*	*	*	*	ZONE2 KEY6
RCKSK0430022	0	1	1	0	1	0	0	0	0	0	*	*	*	*	*	*	*	*	*	*	ZONE2 KEY7
RCKSK0430023	1	1	1	0	1	0	0	0	0	0	*	*	*	*	*	*	*	*	*	*	ZONE2 KEY8
RCKSK0430024	0	0	0	1	1	0	0	0	0	0	*	*	*	*	*	*	*	*	*	*	ZONE2 KEY9
RCKSK0430025	1	0	0	1	1	0	0	0	0	0	*	*	*	*	*	*	*	*	*	*	ZONE2 KEY9
RCKSK0430027	1	1	0	1	1	0	0	0	0	0	*	*	*	*	*	*	*	*	*	*	ZONE2 CURSOR UP
RCKSK0430028	0	0	1	1	1	0	0	0	0	0	*	*	*	*	*	*	*	*	*	*	ZONE2 CURSOR DOWN
RCKSK0430029	1	0	1	1	1	0	0	0	0	0	*	*	*	*	*	*	*	*	*	*	ZONE2 CURSOR LEFT
RCKSK0430030	0	1	1	1	1	0	0	0	0	0	*	*	*	*	*	*	*	*	*	*	ZONE2 CURSOR RIGHT
RCKSK0430031	1	1	1	1	1	0	0	0	0	0	*	*	*	*	*	*	*	*	*	*	ZONE2 ENTER
RCKSK0430034	0	1	0	0	0	1	0	0	0	0	*	*	*	*	*	*	*	*	*	*	ZONE2 RETURN
RCKSK0430036	0	0	1	0	0	1	0	0	0	0	*	*	*	*	*	*	*	*	*	*	ZONE2 MEMORY ※ NA only
RCKSK0430292	0	0	1	0	0	1	0	0	1	0	*	*	*	*	*	*	*	*	*	*	ZONE2 QUICK SELECT 1
RCKSK0430293	1	0	1	0	0	1	0	0	1	0	*	*	*	*	*	*	*	*	*	*	ZONE2 QUICK SELECT 2
RCKSK0430294	0	1	1	0	0	1	0	0	1	0	*	*	*	*	*	*	*	*	*	*	ZONE2 QUICK SELECT 3
RCKSK0430295	1	1	1	0	0	1	0	0	1	0	*	*	*	*	*	*	*	*	*	*	ZONE2 QUICK SELECT 4
RCKSK0430296	0	0	0	1	0	1	0	0	1	0	*	*	*	*	*	*	*	*	*	*	ZONE2 QUICK SELECT 5
RCKSK0430368	1	0	0	0	1	1	1	0	0	0	*	*	*	*	*	*	*	*	*	*	ZONE2 VOLUME UP
RCKSK0430369	1	0	0	0	1	1	1	0	0	0	*	*	*	*	*	*	*	*	*	*	ZONE2 VOLUME DOWN
RCKSK0430370	1	1	0	0	1	1	1	0	1	0	*	*	*	*	*	*	*	*	*	*	ZONE2 VOLUME MUTE
RCKSK0430370	1	1	0	0	1	1	1	0	1	0	*	*	*	*	*	*	*	*	*	*	ZONE2 VR PRESET(MUTE)
RCKSK0430372	0	0	1	0	1	1	1	0	1	0	*	*	*	*	*	*	*	*	*	*	ZONE2 VR PRESET1(0dB)
RCKSK0430373	1	0	1	0	1	1	1	0	1	0	*	*	*	*	*	*	*	*	*	*	ZONE2 VR PRESET2(-20dB)
RCKSK0430374	0	1	1	0	1	1	1	0	1	0	*	*	*	*	*	*	*	*	*	*	ZONE2 VR PRESET3(-40dB)
RCKSK0430691	1	1	0	0	1	1	0	1	0	1	*	*	*	*	*	*	*	*	*	*	ZONE2 Internet Radio
RCKSK0430692	0	0	1	0	1	1	0	1	0	1	*	*	*	*	*	*	*	*	*	*	Main Zone Source CALL
RCKSK0430698	0	1	0	1	1	1	0	1	0	1	*	*	*	*	*	*	*	*	*	*	ZONE2 CD / PHONO
RCKSK0430704	0	0	0	0	0	0	1	1	0	1	*	*	*	*	*	*	*	*	*	*	ZONE2 PHONO
RCKSK0430705	1	0	0	0	0	0	1	1	0	1	*	*	*	*	*	*	*	*	*	*	ZONE2 TUNER
RCKSK0430706	0	1	0	0	0	0	1	1	0	1	*	*	*	*	*	*	*	*	*	*	ZONE2 CD
RCKSK0430711	1	1	1	0	0	0	1	1	0	1	*	*	*	*	*	*	*	*	*	*	ZONE2 HEOS MUSIC
RCKSK0430715	1	1	0	1	0	0	1	0	1	0	*	*	*	*	*	*	*	*	*	*	ZONE2 TUNER
RCKSK0430716	0	0	1	1	0	0	1	1	0	1	*	*	*	*	*	*	*	*	*	*	ZONE2 HEOS MUSIC
RCKSK0430718	0	1	1	1	0	0	1	1	0	1	*	*	*	*	*	*	*	*	*	*	ZONE2 USB
RCKSK0430719	1	1	1	1	0	0	1	1	0	1	*	*	*	*	*	*	*	*	*	*	ZONE2 TUNER
RCKSK0430720	0	0	0	0	1	0	1	0	1	0	*	*	*	*	*	*	*	*	*	*	ZONE2 DVD
RCKSK0430721	1	0	0	0	1	0	1	1	0	1	*	*	*	*	*	*	*	*	*	*	ZONE2 Blu-ray
RCKSK0430722	0	1	0	0	1	0	1	1	0	1	*	*	*	*	*	*	*	*	*	*	ZONE2 TV AUDIO
RCKSK0430723	1	1	0	0	1	0	1	1	0	1	*	*	*	*	*	*	*	*	*	*	ZONE2 CBL/SAT
RCKSK0430725	1	0	1	0	1	0	1	1	0	1	*	*	*	*	*	*	*	*	*	*	ZONE2 GAME
RCKSK0430726	0	1	1	0	1	0	1	1	0	1	*	*	*	*	*	*	*	*	*	*	ZONE2 MEDIA PLAYER
RCKSK0430729	1	0	0	1	1	0	1	1	0	1	*	*	*	*	*	*	*	*	*	*	ZONE2 AUX
RCKSK0430730	0	1	0	1	1	0	1	1	0	1	*	*	*	*	*	*	*	*	*	*	ZONE2 8K
RCKSK0430732	0	0	1	1	0	1	0	1	1	0	*	*	*	*	*	*	*	*	*	*	ZONE2 DV/Blu-ray
RCKSK0430735	1	1	1	1	0	0	1	1	0	1	*	*	*	*	*	*	*	*	*	*	ZONE2 MEDIA PLAYER
RCKSK0430741	1	0	1	0	0	1	1	0	1	0	*	*	*	*	*	*	*	*	*	*	ZONE2 INTERNET RADIO(Recent Play)
RCKSK0430751	1	1	1	1	0	1	1	0	1	0	*	*	*	*	*	*	*	*	*	*	ZONE2 Bluetooth
RCKSK0430787	1	1	0	0	1	0	0	0	1	1	*	*	*	*	*	*	*	*	*	*	ZONE2 INPUT SOURCE SELECT Right
RCKSK0430788	0	0	1	0	1	0	0	0	1	1	*	*	*	*	*	*	*	*	*	*	ZONE2 INPUT SOURCE SELECT Left
RCKSK0430788	0	0	1	0	0	0	1	0	1	1	*	*	*	*	*	*	*	*	*	*	ZONE2 SLEEP
RCKSK0430950	0	1	1	0	1	1	0	1	1	1	*	*	*	*	*	*	*	*	*	*	ZONE2 PAGE Previous
RCKSK0430951	1	1	1	0	1	1	0	1	1	1	*	*	*	*	*	*	*	*	*	*	ZONE2 PAGE Next
RCKSK0430970	0	1	0	1	0	1	0	1	1	1	*	*	*	*	*	*	*	*	*	*	ZONE2 TUNING UP ※ NA only
RCKSK0430971	1	1	0	1	0	1	0	1	1	1	*	*	*	*	*	*	*	*	*	*	ZONE2 TUNING DOWN ※ NA only
RCKSK0430972	0	0	1	1	0	0	1	1	1	1	*	*	*	*	*	*	*	*	*	*	ZONE2 PRESET CH UP ※ NA only
RCKSK0430973	1	0	1	1	0	0	1	1	1	1	*	*	*	*	*	*	*	*	*	*	ZONE2 PRESET CH DOWN ※ NA only
RCKSK0430976	0	0	0	0	1	0	1	1	1	1	*	*	*	*	*	*	*	*	*	*	ZONE2 Rewind
RCKSK0430977	1	0	0	0	1	0	1	1	1	1	*	*	*	*	*	*	*	*	*	*	ZONE2 BAND FM ※ NA only
RCKSK0430978	0	1	0	0	1	0	1	1	1	1	*	*	*	*	*	*	*	*	*	*	ZONE2 BAND AM ※ NA only
RCKSK0430979	1	1	0	0	1	0	1	1	1	1	*	*	*	*	*	*	*	*	*	*	ZONE2 Fast Forward
RCKSK0430983	1	1	1	0	1	0	1	1	1	1	*	*	*	*	*	*	*	*	*	*	ZONE2 SEARCH ※ NA only
RCKSK0430992	0	0	0	0	0	1	1	1	1	1	*	*	*	*	*	*	*	*	*	*	ZONE2 PLAY/PAUSE
RCKSK0430993	1	0	0	0	0	1	1	1	1	1	*	*	*	*	*	*	*	*	*	*	ZONE2 STOP
RCKSK0430994	0	1	0	0	0	1	1	1	1	1	*	*	*	*	*	*	*	*	*	*	ZONE2 PAUSE
RCKSK0430995	1	1	0	0	0	1	1	1	1	1	*	*	*	*	*	*	*	*	*	*	ZONE2 SKIP MINUS/TUNING DOWN
RCKSK0430996	0	0	1	0	0	1	1	1	1	1	*	*	*	*	*	*	*	*	*	*	ZONE2 SKIP PLUS/TUNING UP
RCKSK0430997	1	0	1	0	0	1	1	1	1	1	*	*	*	*	*	*	*	*	*	*	ZONE2 TUNING ▲ ※ NA only
RCKSK0430998	0	1	1	0	0	1	1	1	1	1	*	*	*	*	*	*	*	*	*	*	ZONE2 TUNING ▼ ※ NA only

ZONE3

REMOTE ID SET: 1

DENON CODE								Parity				GENRE1				GENRE2											
1	2	3	4	5	6	7	8	9	10	11	12	13	14	15	16	17	18	19	20	21	22	23	24	25	26	27	28
0	0	1	0	1	0	1	0	0	1	0	0	1	1	0	0	0	0	0	0	0	0	1	0	1	1	0	0

REMOTE ID SET: 2-4

DENON CODE								Parity				GENRE1				GENRE2											
1	2	3	4	5	6	7	8	9	10	11	12	13	14	15	16	17	18	19	20	21	22	23	24	25	26	27	28
0	0	1	0	1	0	1	0	0	1	0	0	1	1	0	0	0	0	0	0	0	0	1	0	1	1	0	0

No.	Data								ID								Key Name
	29																

ANALOG TUNER ※ NA only

REMOTE ID SET: 1

DENON CODE								Parity				GENRE1				GENRE2											
4		5		2		3		0				4				1											
1	2	3	4	5	6	7	8	9	10	11	12	13	14	15	16	17	18	19	20	21	22	23	24	25	26	27	28
0	0	1	0	1	0	1	0	0	1	0	0	1	1	0	0	0	0	0	0	0	0	1	0	1	0	0	0

REMOTE ID SET: 2-4

DENON CODE								Parity				GENRE1				GENRE2											
4		5		2		3		0				4				2											
1	2	3	4	5	6	7	8	9	10	11	12	13	14	15	16	17	18	19	20	21	22	23	24	25	26	27	28
0	0	1	0	1	0	1	0	0	1	0	0	1	1	0	0	0	0	0	0	0	0	1	0	0	1	0	0

No.	Data																ID								Key Name		
	29	30	31	32	33	34	35	36	37	38	39	40	41	42	43	44	45	46	47	48							
RCKSK0410144	0	0	0	0	1	0	0	1	0	0	0	*	*	*	*	*	*	*	*	*	*	*	*	*	*	*	*
RCKSK0410145	1	0	0	0	1	0	0	1	0	0	0	*	*	*	*	*	*	*	*	*	*	*	*	*	*	*	*
RCKSK0410146	0	1	0	0	1	0	0	1	0	0	0	*	*	*	*	*	*	*	*	*	*	*	*	*	*	*	*
RCKSK0410147	1	1	0	0	1	0	0	1	0	0	0	*	*	*	*	*	*	*	*	*	*	*	*	*	*	*	*
RCKSK0410152	0	0	0	1	1	0	0	1	0	0	0	*	*	*	*	*	*	*	*	*	*	*	*	*	*	*	*
RCKSK0410153	1	0	0	1	1	0	0	1	0	0	0	*	*	*	*	*	*	*	*	*	*	*	*	*	*	*	*
RCKSK0410154	0	1	0	1	1	0	0	1	0	0	0	*	*	*	*	*	*	*	*	*	*	*	*	*	*	*	*
RCKSK0410156	0	0	1	1	1	0	0	1	0	0	0	*	*	*	*	*	*	*	*	*	*	*	*	*	*	*	*
RCKSK0410160	0	0	0	0	1	0	0	1	0	0	0	*	*	*	*	*	*	*	*	*	*	*	*	*	*	*	*
RCKSK0410163	1	1	0	0	0	1	0	1	0	0	0	*	*	*	*	*	*	*	*	*	*	*	*	*	*	*	*
RCKSK0410166	0	1	1	0	0	1	0	1	0	0	0	*	*	*	*	*	*	*	*	*	*	*	*	*	*	*	*
RCKSK0410169	1	0	0	1	0	1	0	1	0	0	0	*	*	*	*	*	*	*	*	*	*	*	*	*	*	*	*
RCKSK0410170	0	1	0	1	0	1	0	1	0	0	0	*	*	*	*	*	*	*	*	*	*	*	*	*	*	*	*
RCKSK0410171	1	1	0	1	0	1	0	1	0	0	0	*	*	*	*	*	*	*	*	*	*	*	*	*	*	*	*
RCKSK0410173	1	0	1	1	0	1	0	1	0	0	0	*	*	*	*	*	*	*	*	*	*	*	*	*	*	*	*
RCKSK0410174	0	1	1	1	0	1	0	1	0	0	0	*	*	*	*	*	*	*	*	*	*	*	*	*	*	*	*
RCKSK0410175	1	1	1	1	0	1	0	1	0	0	0	*	*	*	*	*	*	*	*	*	*	*	*	*	*	*	*
RCKSK0410176	0	0	0	0	1	1	0	1	0	0	0	*	*	*	*	*	*	*	*	*	*	*	*	*	*	*	*
RCKSK0410177	1	0	0	0	1	1	0	1	0	0	0	*	*	*	*	*	*	*	*	*	*	*	*	*	*	*	*
RCKSK0410178	0	1	0	0	1	1	0	1	0	0	0	*	*	*	*	*	*	*	*	*	*	*	*	*	*	*	*
RCKSK0410179	1	1	0	0	1	1	0	1	0	0	0	*	*	*	*	*	*	*	*	*	*	*	*	*	*	*	*
RCKSK0410180	0	0	1	0	1	1	0	1	0	0	0	*	*	*	*	*	*	*	*	*	*	*	*	*	*	*	*
RCKSK0410181	1	0	1	0	1	1	0	1	0	0	0	*	*	*	*	*	*	*	*	*	*	*	*	*	*	*	*
RCKSK0410182	0	1	1	0	0	1	0	1	0	0	0	*	*	*	*	*	*	*	*	*	*	*	*	*	*	*	*
RCKSK0410183	1	1	1	0	1	1	0	1	0	0	0	*	*	*	*	*	*	*	*	*	*	*	*	*	*	*	*
RCKSK0410184	0	0	0	1	1	1	0	1	0	0	0	*	*	*	*	*	*	*	*	*	*	*	*	*	*	*	*
RCKSK0410185	1	0	0	1	1	1	0	1	0	0	0	*	*	*	*	*	*	*	*	*	*	*	*	*	*	*	*
RCKSK0410241	1	0	0	0	1	1	1	1	0	0	0	*	*	*	*	*	*	*	*	*	*	*	*	*	*	*	*

HEOS MUSIC

REMOTE ID SET: 1

DENON CODE								Parity				GENRE1				GENRE2											
4		5		2		3		0				4				7											
1	2	3	4	5	6	7	8	9	10	11	12	13	14	15	16	17	18	19	20	21	22	23	24	25	26	27	28
0	0	1	0	1	0	1	0	0	1	0	0	1	1	0	0	0	0	0	0	0	0	1	0	1	1	1	0

REMOTE ID SET: 2-4

DENON CODE								Parity				GENRE1				GENRE2											
4		5		2		3		0				4				8											
1	2	3	4	5	6	7	8	9	10	11	12	13	14	15	16	17	18	19	20	21	22	23	24	25	26	27	28
0	0	1	0	1	0	1	0	0	1	0	0	1	1	0	0	0	0	0	0	0	0	1	0	0	0	0	1

No.	Data																ID								Key Name		
	29	30	31	32	33	34	35	36	37	38	39	40	41	42	43	44	45	46	47	48							
RCKSK0470027	1	1	0	1	1	0	0	0	0	0	0	*	*	*	*	*	*	*	*	*	*	*	*	*	*	*	*
RCKSK0470028	0	0	1	1	1	0	0	0	0	0	0	*	*	*	*	*	*	*	*	*	*	*	*	*	*	*	*
RCKSK0470029	1	0	1	1	1	0	0	0	0	0	0	*	*	*	*	*	*	*	*	*	*	*	*	*	*	*	*
RCKSK0470030	0	1	1	1	1	0	0	0	0	0	0	*	*	*	*	*	*	*	*	*	*	*	*	*	*	*	*
RCKSK0470031	1	1	1	1	1	0	0	0	0	0	0	*	*	*	*	*	*	*	*	*	*	*	*	*	*	*	*
RCKSK0470034	0	1	0	0	0	1	0	0	0	0	0	*	*	*	*	*	*	*	*	*	*	*	*	*	*	*	*
RCKSK0470773	1	0	1	0	0	0	0	0	1	1	1	*	*	*	*	*	*	*	*	*	*	*	*	*	*	*	*
RCKSK0470774	0	1	1	0	0	0	0	0	1	1	1	*	*	*	*	*	*	*	*	*	*	*	*	*	*	*	*
RCKSK0470775	1	1	1	0	0	0	0	0	1	1	1	*	*	*	*	*	*	*	*	*	*	*	*	*	*	*	*
RCKSK0470776	0	0	0	1	0	0	0	0	1	1	1	*	*	*	*	*	*	*	*	*	*	*	*	*	*	*	*
RCKSK0470777	1	0	0	1	0	0	0	0	1	1	1	*	*	*	*	*	*	*	*	*	*	*	*	*	*	*	*
RCKSK0470778	0	1	0	1	0	0	0	0	1	1	1	*	*	*	*	*	*	*	*	*	*	*	*	*	*	*	*
RCKSK0470779	1	1	0	1	0	0	0	0	1	1	1	*	*	*	*	*	*	*	*	*	*	*	*	*	*	*	*
RCKSK0470780	0	0	1	1	0	0	0	0	1	1	1	*	*	*	*	*	*	*	*	*	*	*	*	*	*	*	*
RCKSK0470781	1	0	1	1	0	0	0	0	1	1	1	*	*	*	*	*	*	*	*	*	*	*	*	*	*	*	*
RCKSK0470785	1	0	0	0	1	0	0	0	1	1	1	*	*	*	*	*	*	*	*	*	*	*	*	*	*	*	*

Before Servicing
This Unit

Electrical

Mechanical

Repair Information

Updating

DISASSEMBLY

Flowchart

1. FRONT ASSY

2. RADIATOR ASSY

3. REAR ASSY

4. TRANS

EXPLODED VIEW

PACKAGING VIEW

Flowchart

- Remove each part following the flow below.
- Reassemble the removed parts in the reverse order.
- Read "[SAFETY PRECAUTIONS](#)" before reassembling the removed parts.
- If wire bundles are removed or moved during adjustment or part replacement, reshape the wires after completing the work. Failure to shape the wires correctly may cause problems such as noise.
- See "[EXPLODED VIEW](#)"

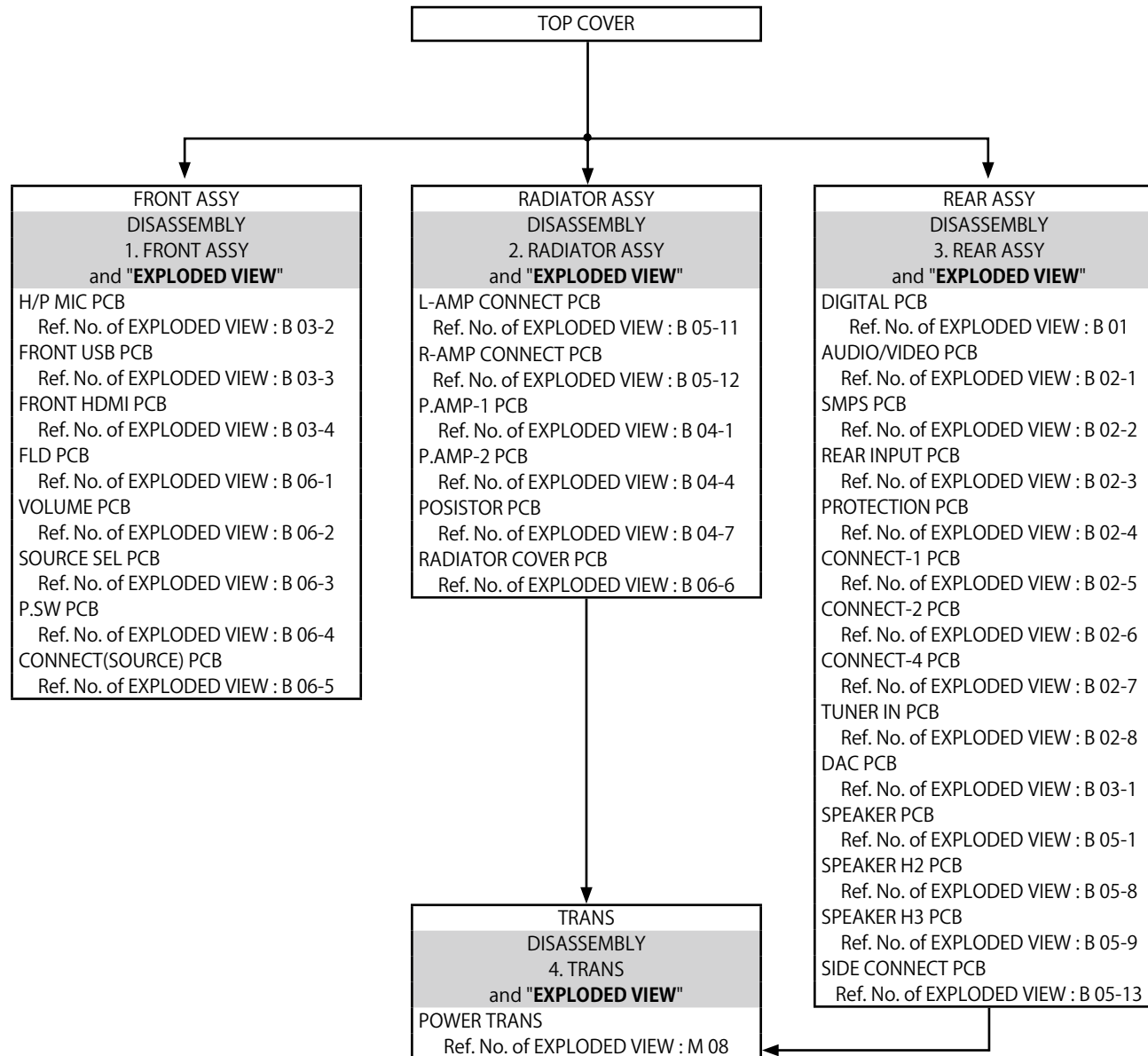

Explanatory Photos for DISASSEMBLY

- For the shooting direction of each photos used in this manual, see the photo below.
- **A, B, C and D** in the photo below indicate the shooting directions of photos.
- The photographs with no shooting direction indicated were taken from the top of the unit.
- Photos of AVR-X6700H E3 are used in this manual.

The viewpoint of each photograph

(Shooting direction : X) [View from the top]

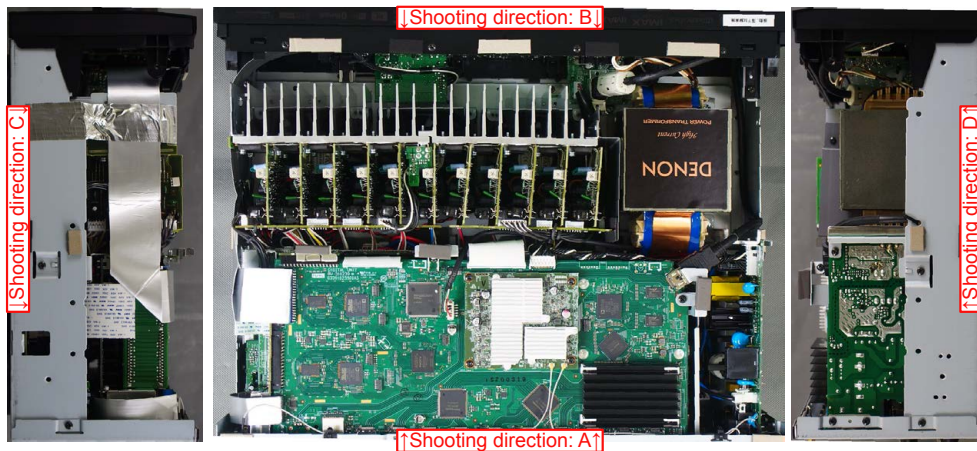

1. FRONT ASSY

Proceeding : **TOP COVER** → **FRONT ASSY**

- (1) Remove the screws.

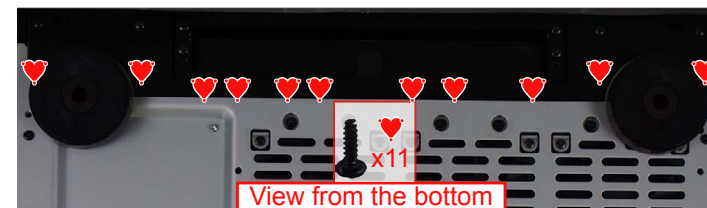

- (2) Remove the screws. Remove the STYLE PIN and connectors. Remove the FFC. Cut the wire clamps.

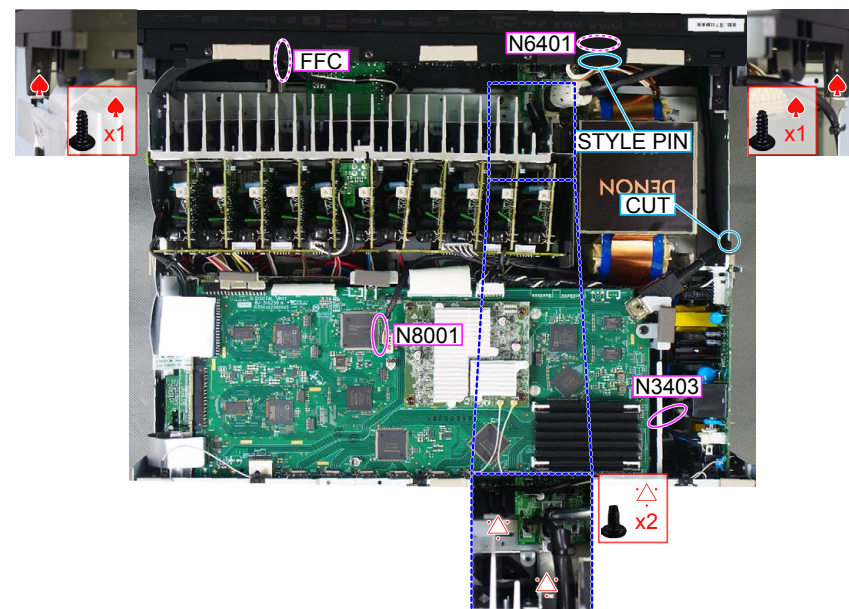

2. RADIATOR ASSY

Proceeding : **TOP COVER** → **FRONT ASSY** → **RADIATOR ASSY**

(1) Remove the screws. Remove the STYLE PIN and connectors.

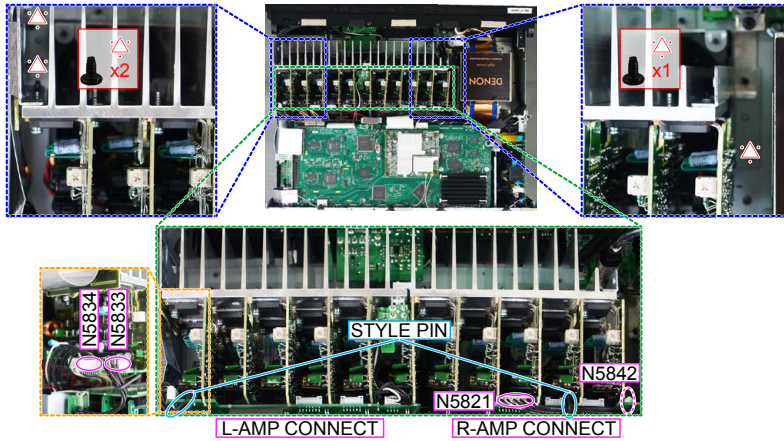

(2) Remove the connector.

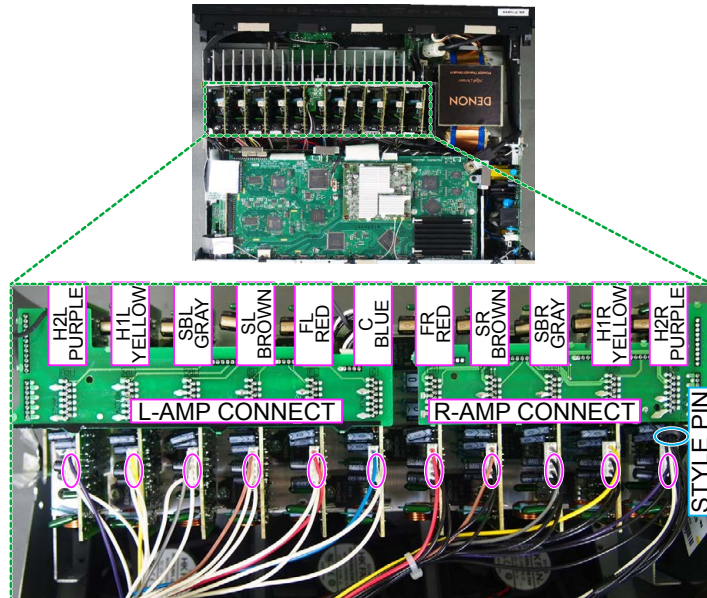

3. REAR ASSY

Proceeding : **TOP COVER** → **REAR ASSY**

(1) Remove the screws.

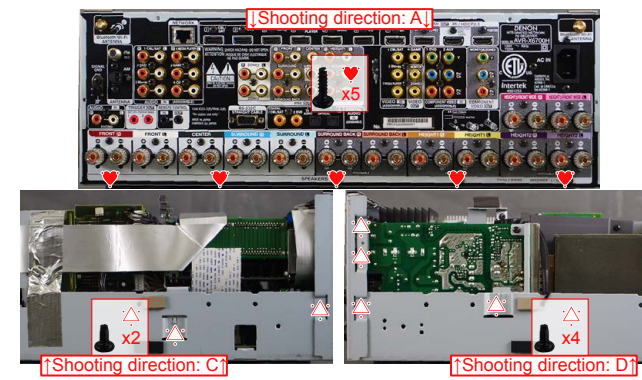

(2) Remove the STYLE PINs and connectors.
Remove the FFC. Remove the screws.

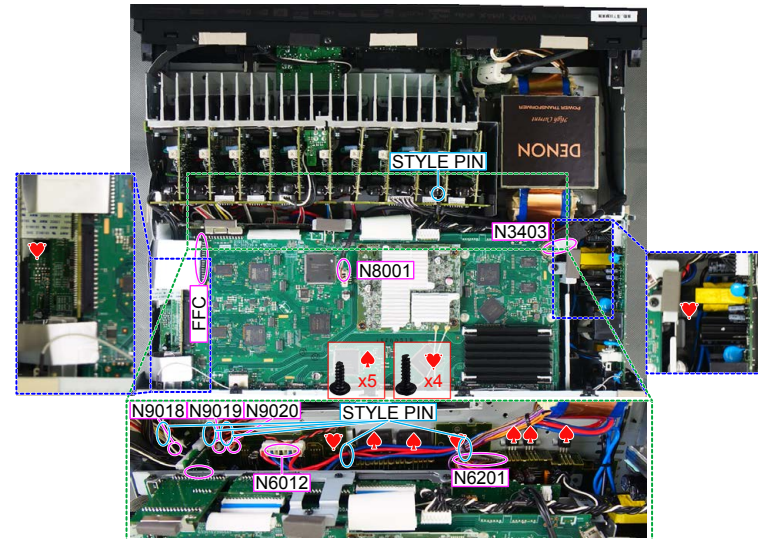

4. TRANS

Proceeding: **TOP COVER** → **RADIATOR ASSY or REAR ASSY** → **TRANS**

(1) Remove the screws. Remove the connector.

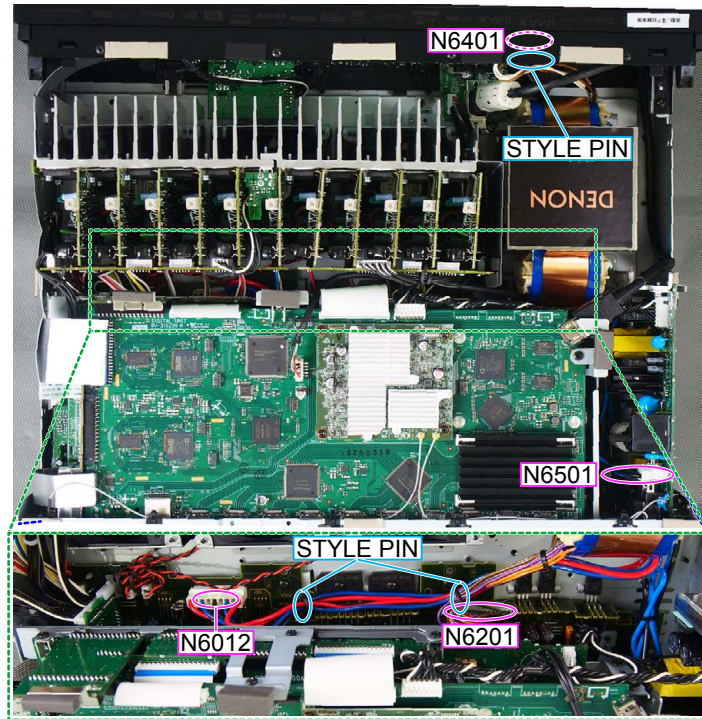

PACKAGING VIEW

AVR-X6700H Parts List : <https://dmedia.soundunited.com/documents/details/27004>

AVR-C6700H Parts List : <https://dmedia.soundunited.com/documents/details/27005>

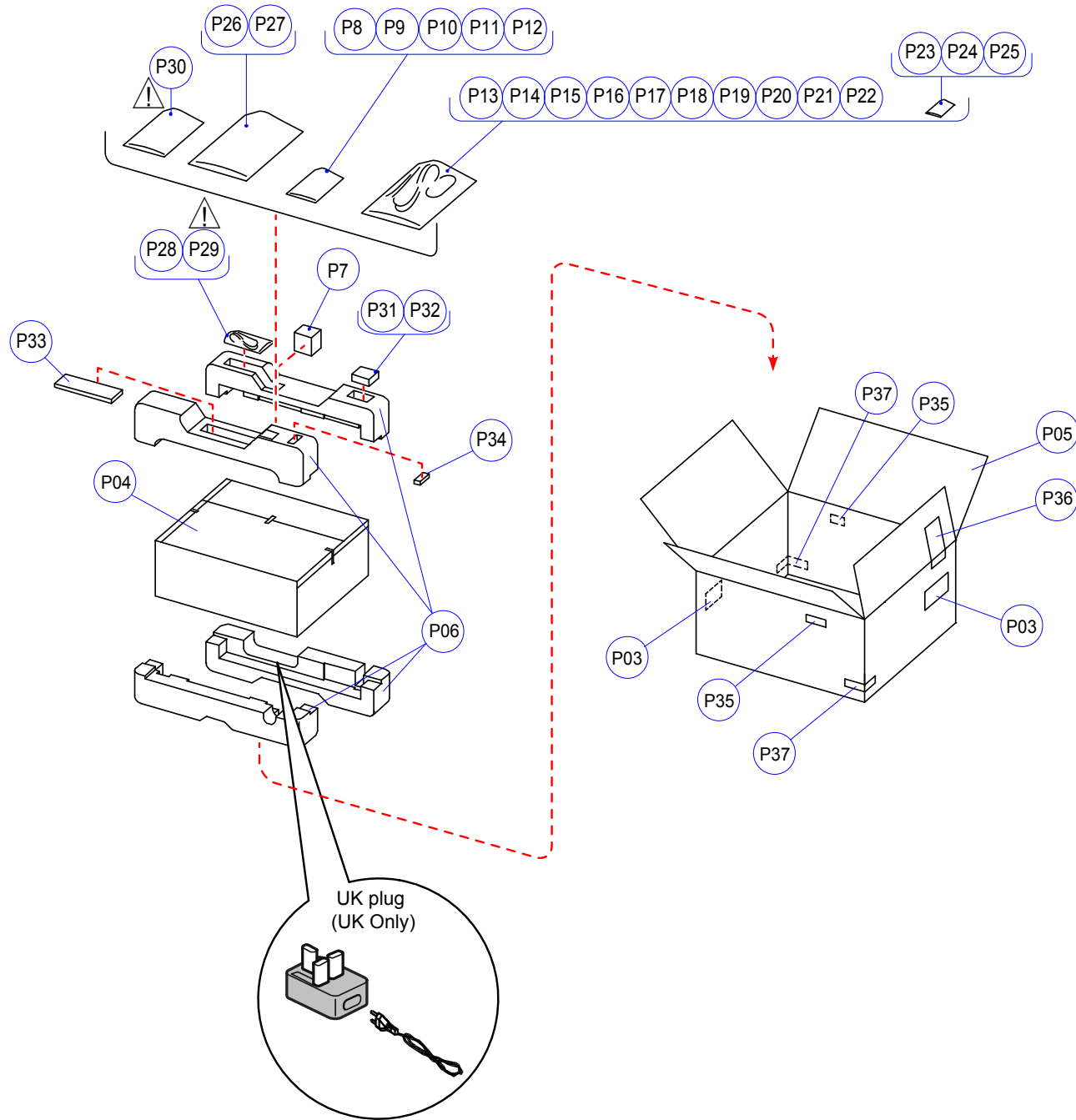

Before Servicing
This Unit

Electrical

Mechanical

Repair Information

Updating

REPAIR INFORMATION

TROUBLE SHOOTING

2. Analog video
3. HDMI/DVI
4. AUDIO
5. Network / Bluetooth / USB
6. SMPS

PROTECTION DIAGRAM

AUDIO CHECK PATH

HDMI "Rx/Tx" Failure Detection

1. Prior checking
2. Preparations for checking HDMI Switcher reception/transmission register
3. Starting detecting the point of failure
4. Device implementation location

CLOCK FLOW & WAVE FORM IN DIGITAL BLOCK

SPECIAL MODE

Special mode setting button

1. Version Display Mode
2. PANEL / REMOTE LOCK Selection Mode
 - 3-1. Selecting the Mode for Service-related
 - 3-2. Protection History Display Mode
 - 3-3. 232C Standby Clear Mode
 - 3-4. Operation Info Mode
 - 3-5. TUNER STEP mode (E3 only)
 - 3-6. Remote ID Setup Mode
4. Protection Pass Mode
5. Network Initialization Mode
6. Clearing of Operation Info
7. Log Capture feature
8. Protection popups

DIAGNOSTIC MODE

Service Path Check Mode

DIAGNOSTIC PATH DIAGRAM

JIG FOR SERVICING

ADJUSTMENT

1.1. The unit does not power on

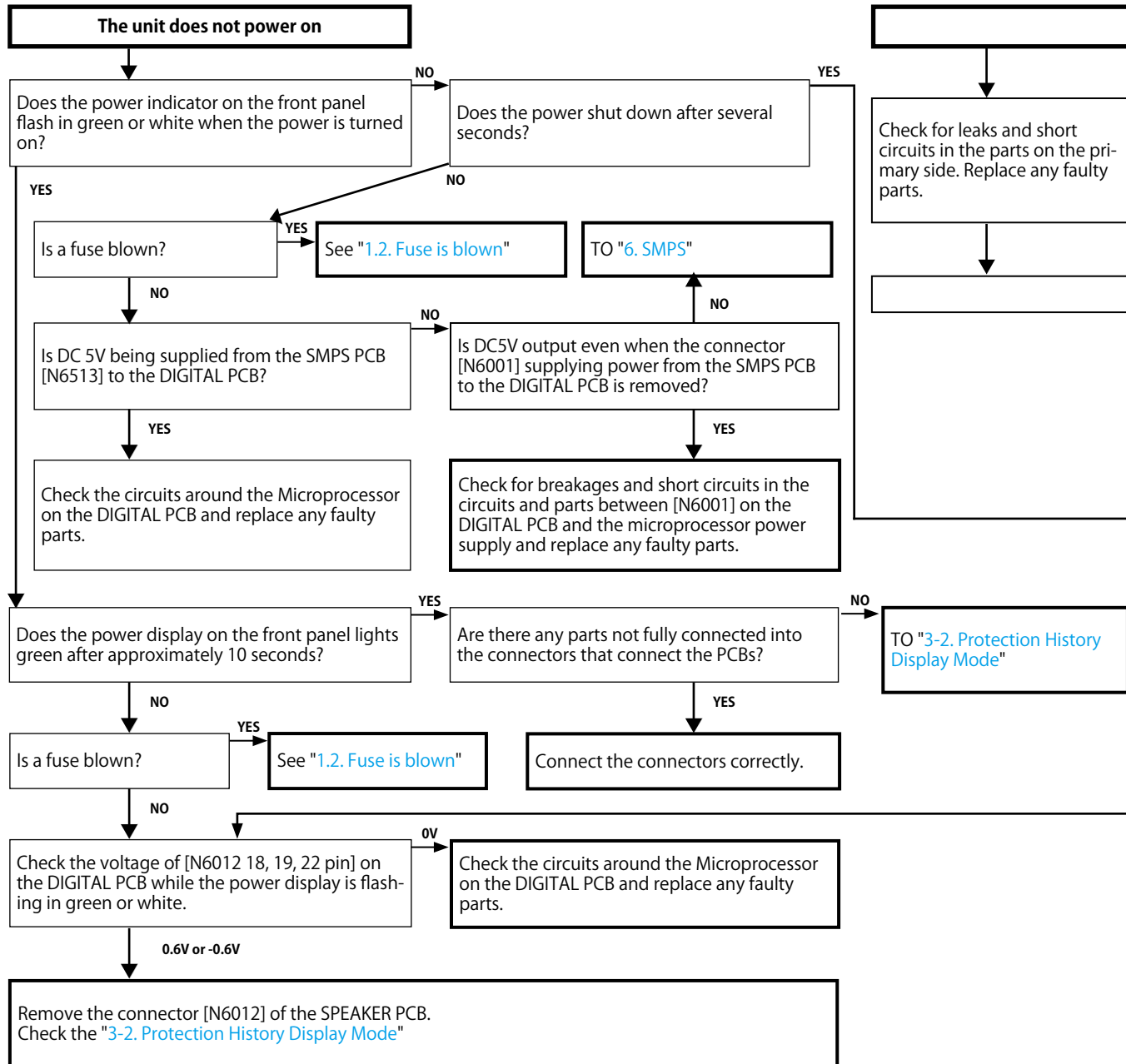

1.2. Fuse is blown

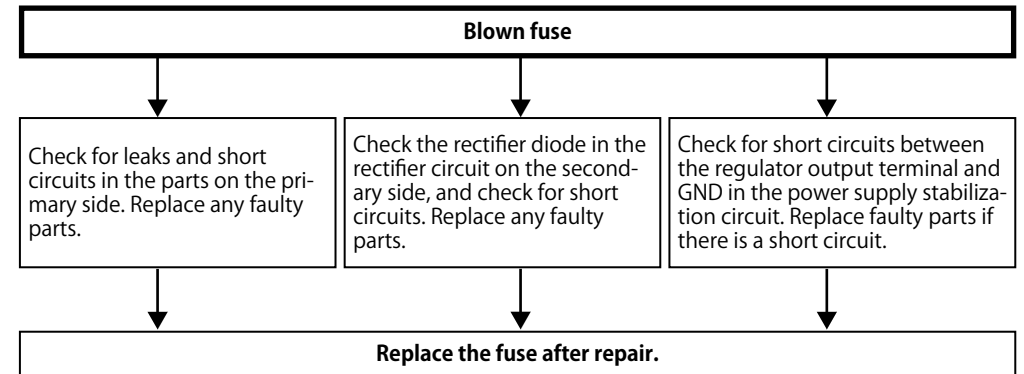

A

Use a jig to extend the DIGITAL PCB

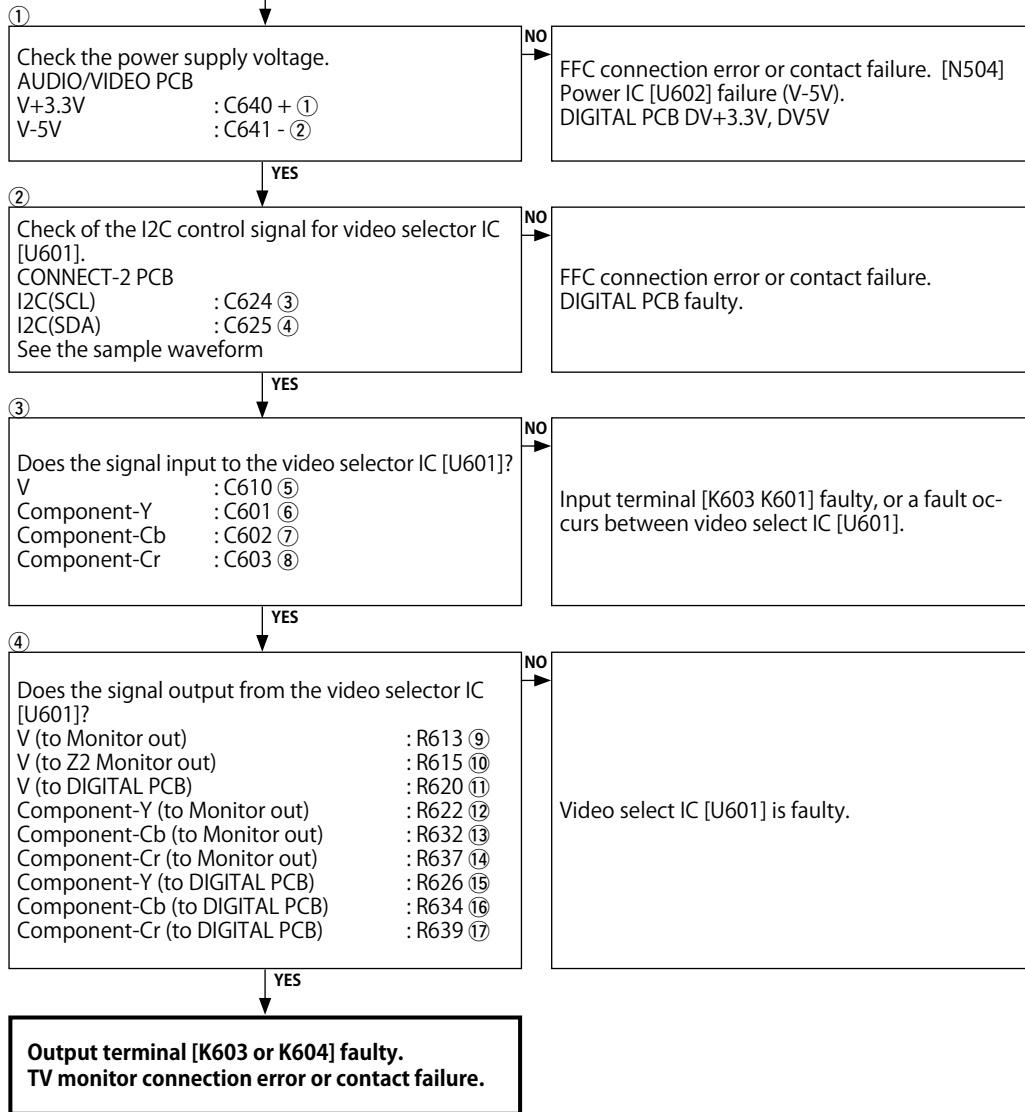

I2C communication wave form (sample)

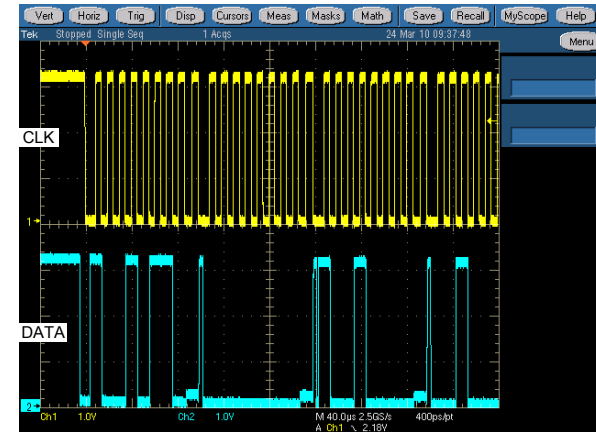

3. HDMI/DVI

3.1. No picture or sound is output (HDMI to HDMI)

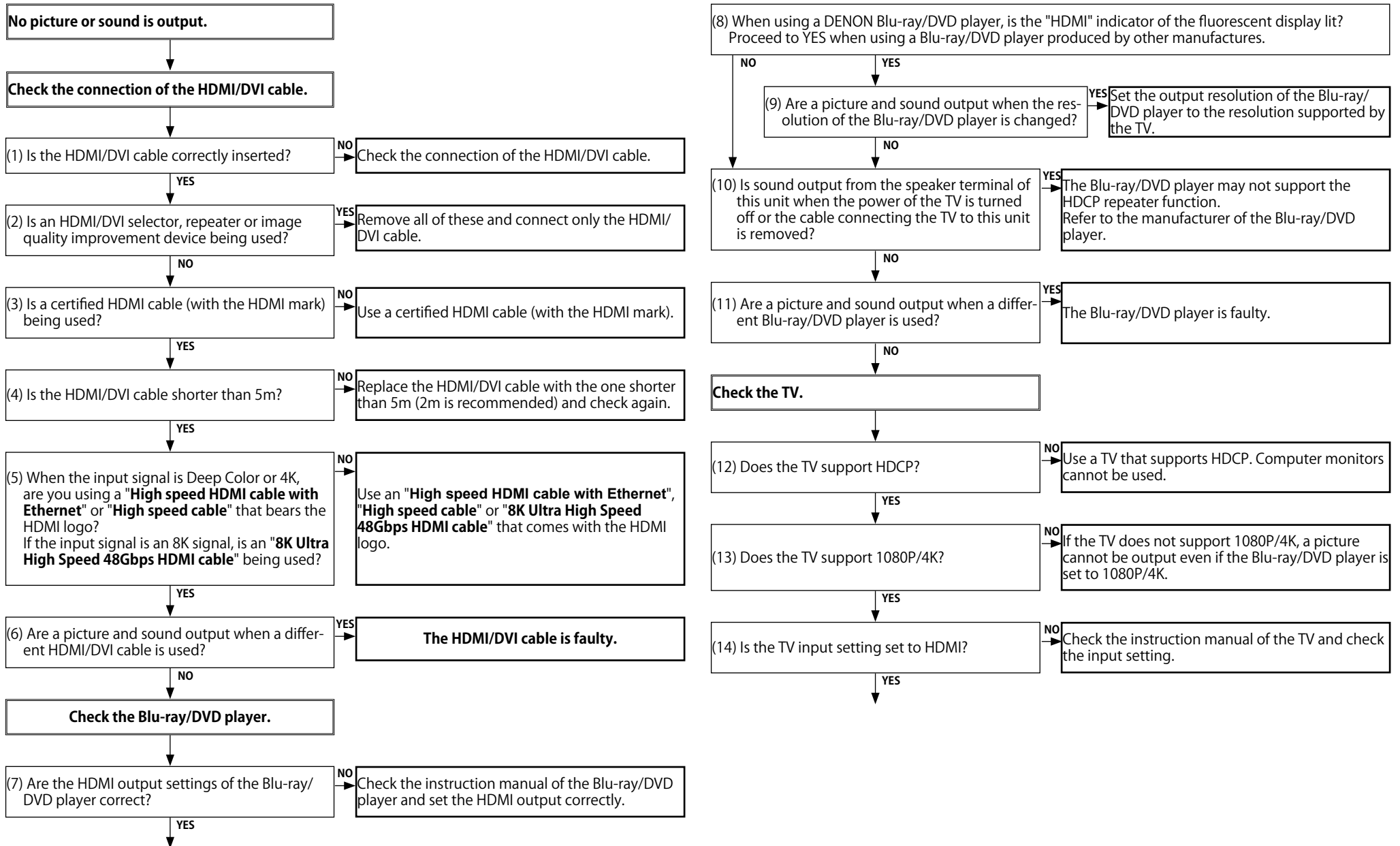

Go to next page.

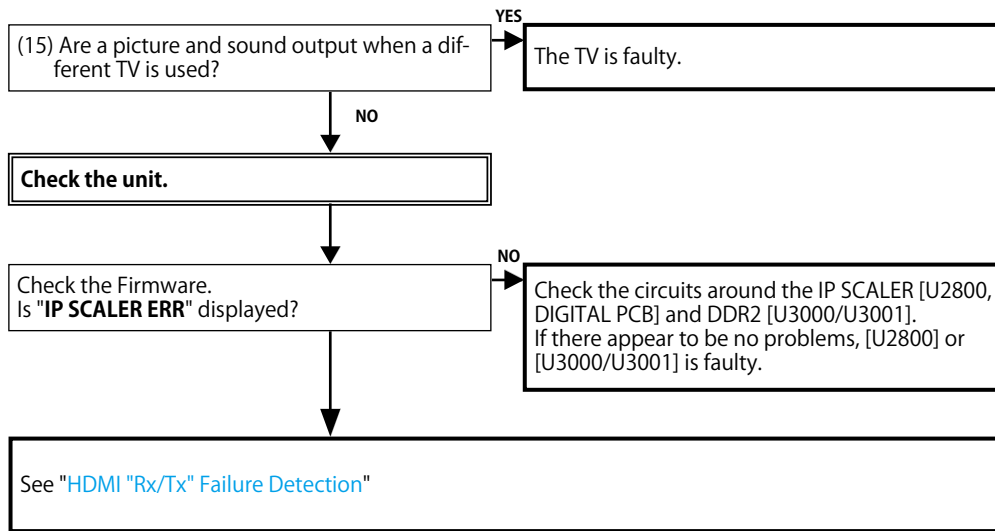

4. AUDIO

4.1. AUDIO CHECK

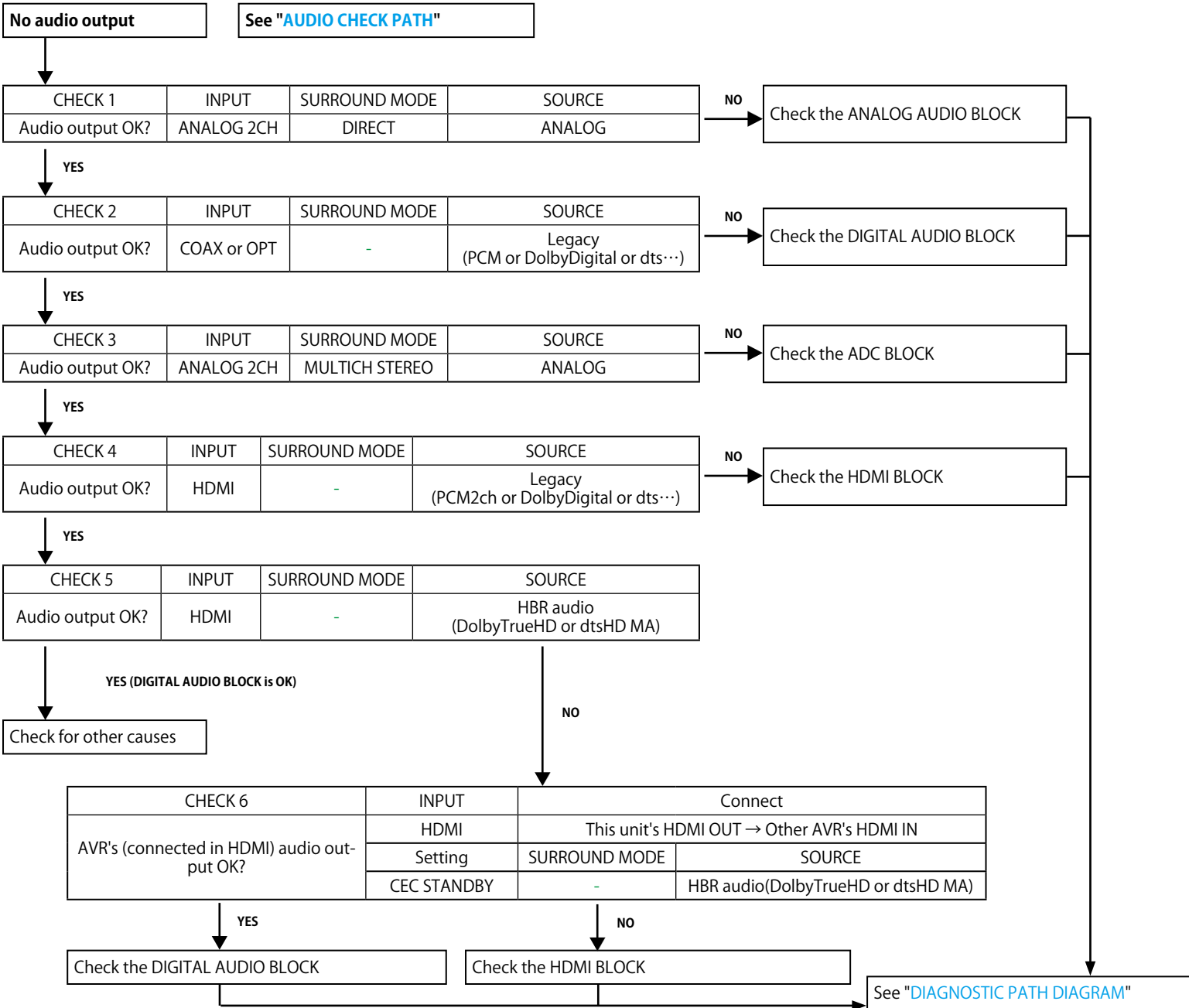

4.2. Power AMP (AMP PCB)

When using the protection pass mode, do not connect speakers to the speaker terminals.

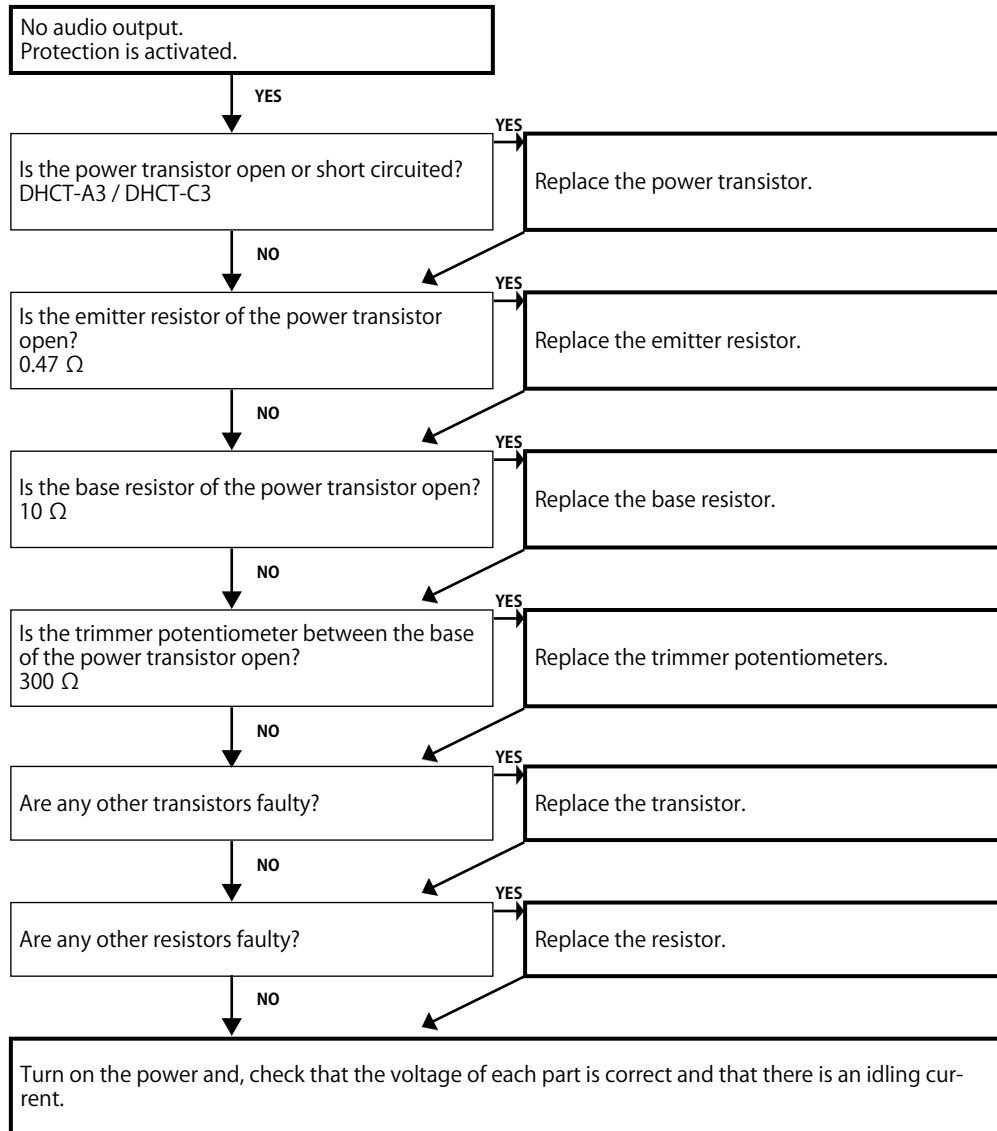

4.3. Analog audio

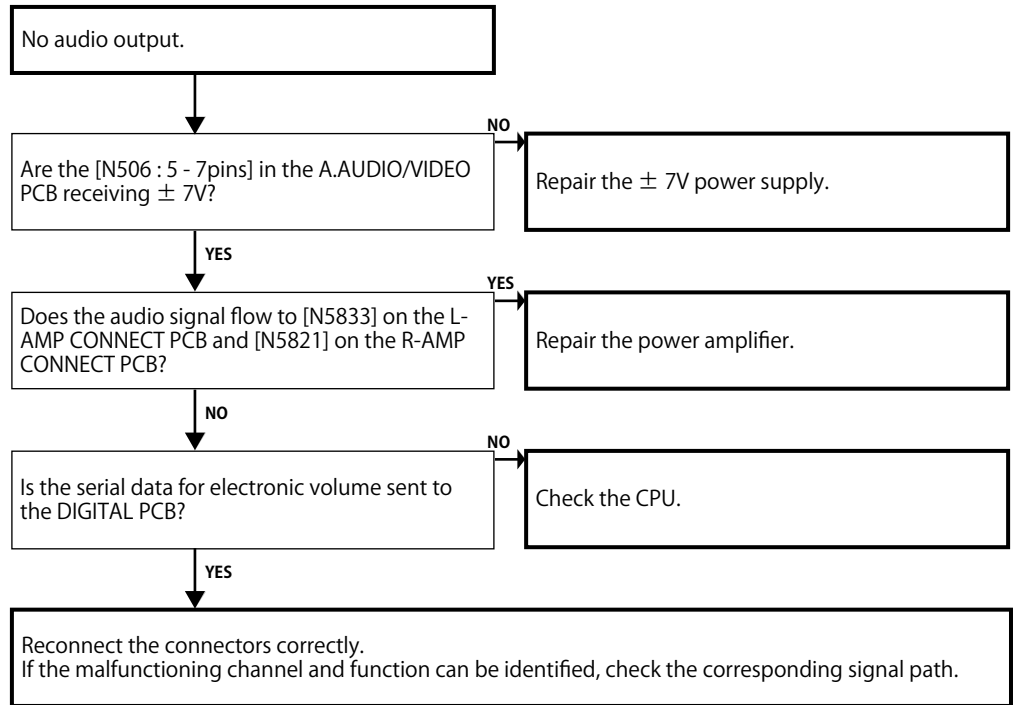

5. Network / Bluetooth / USB

5.1. Cannot connect to the network

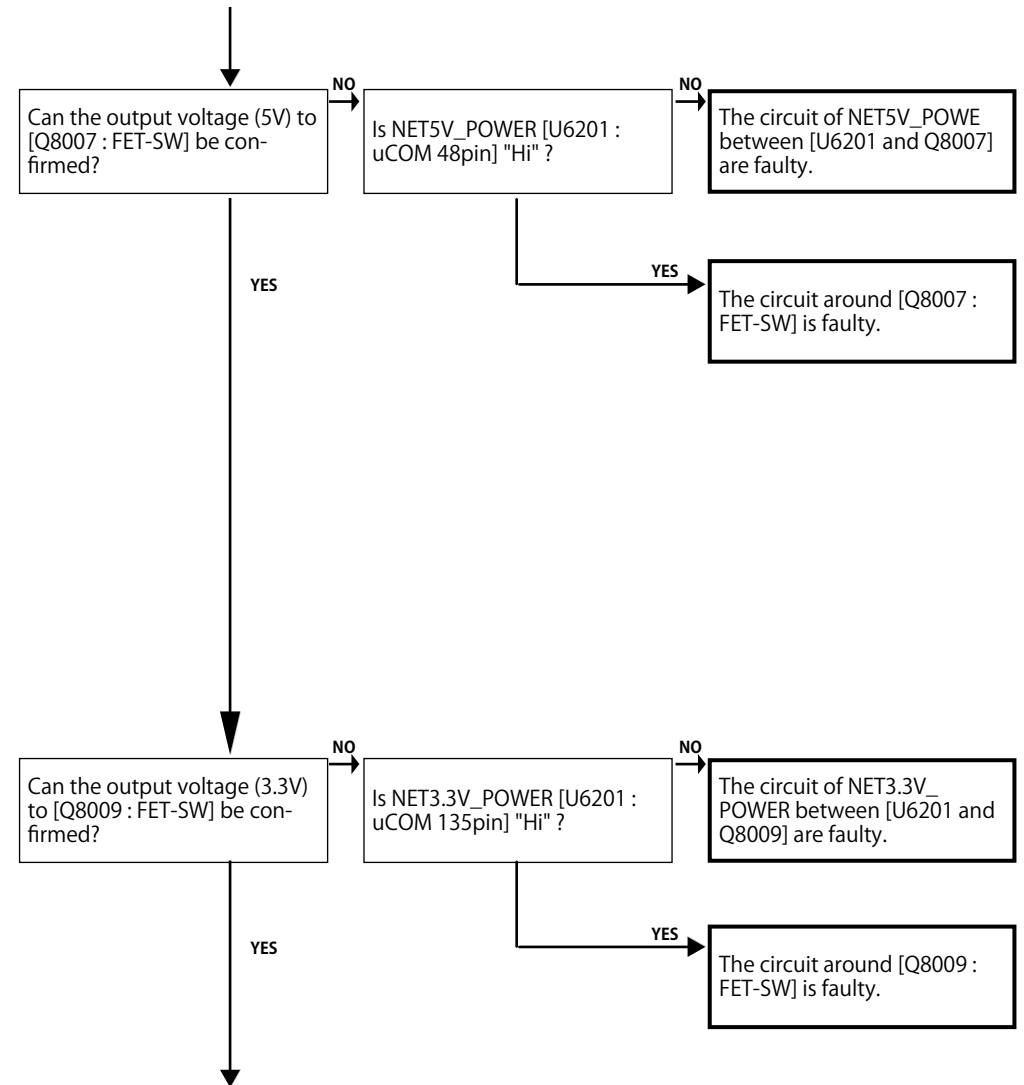
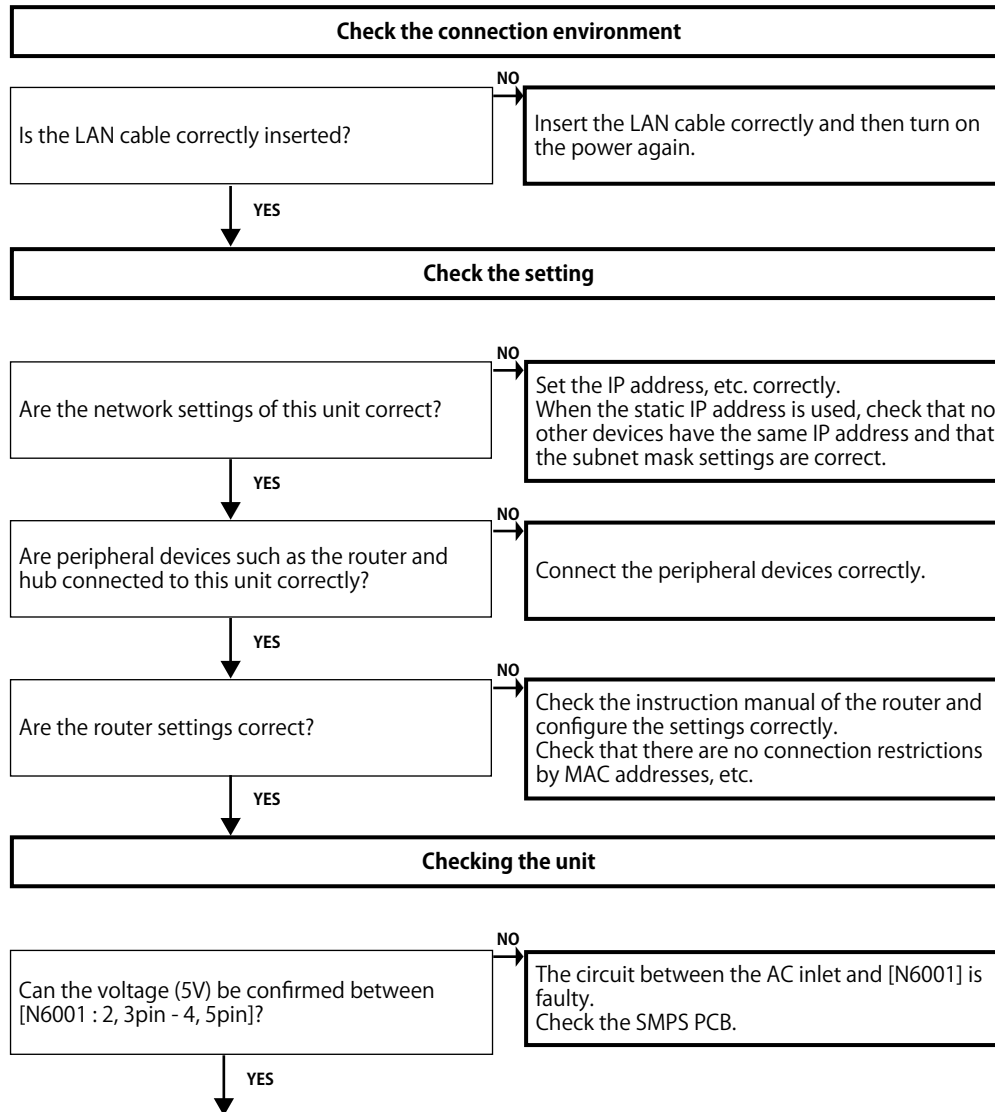

Go to next page.

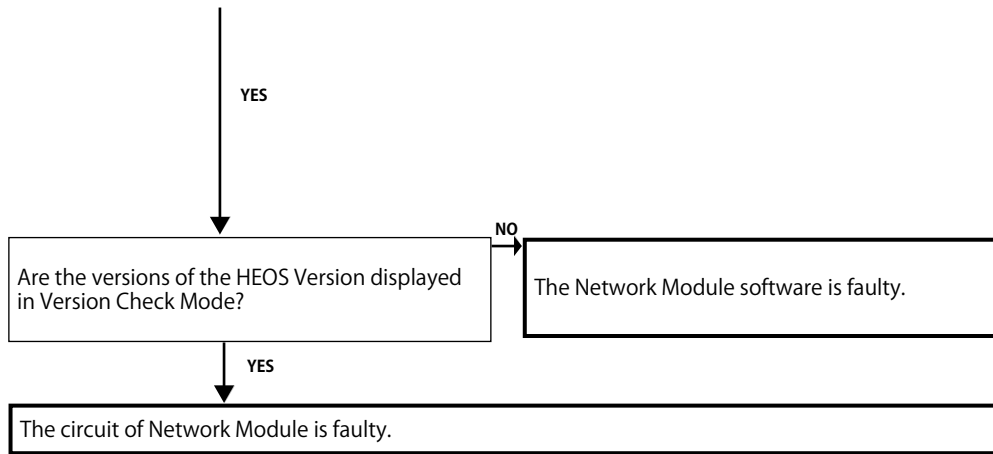

5.2. Cannot establish a Bluetooth connection

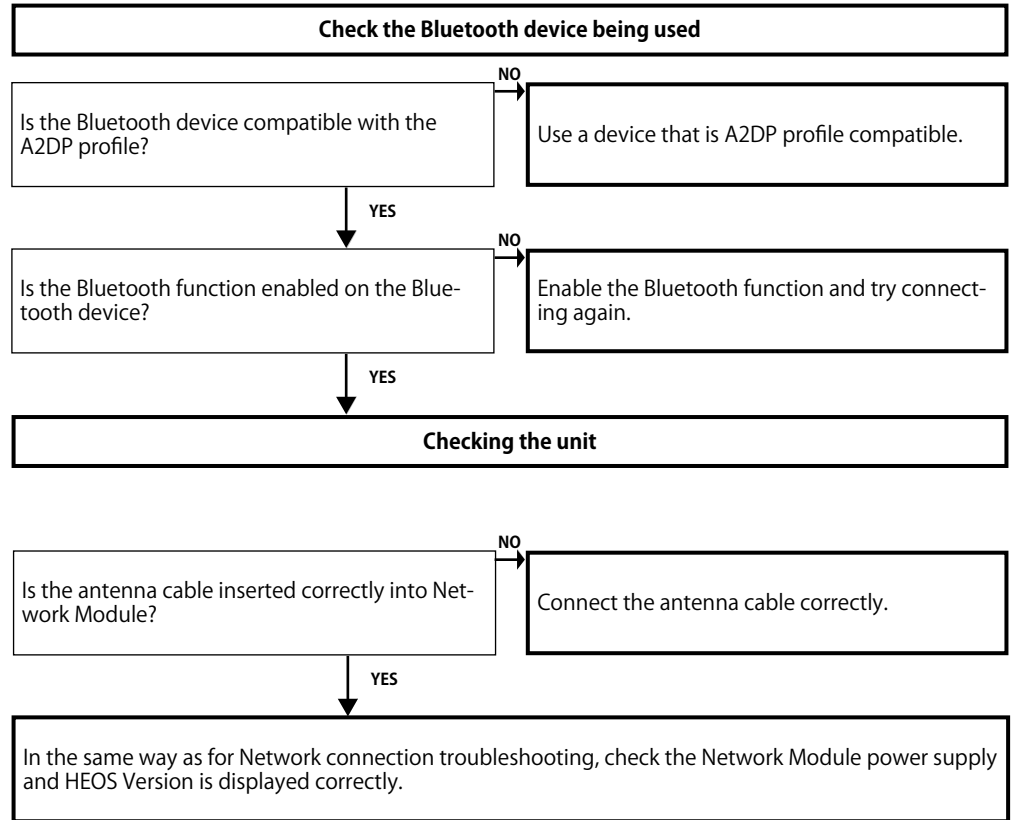

5.3. Cannot recognize the connected USB device

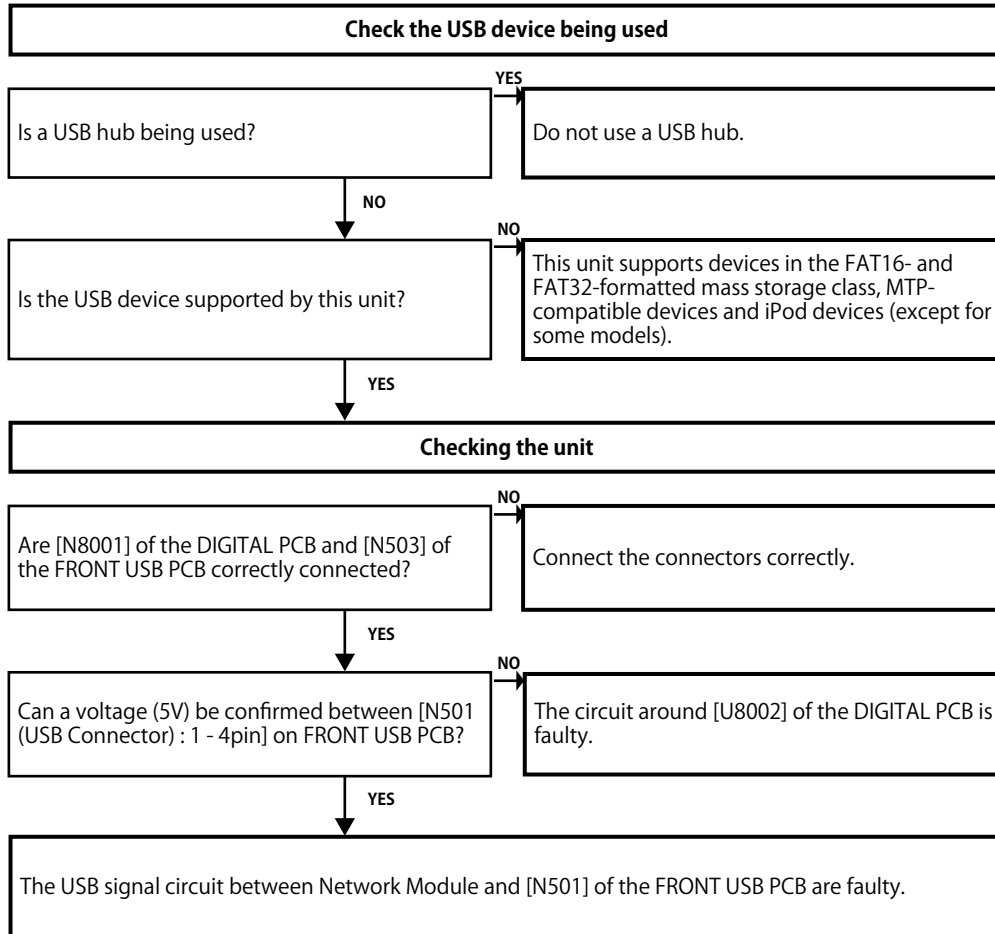

5.4. No picture or sound is output

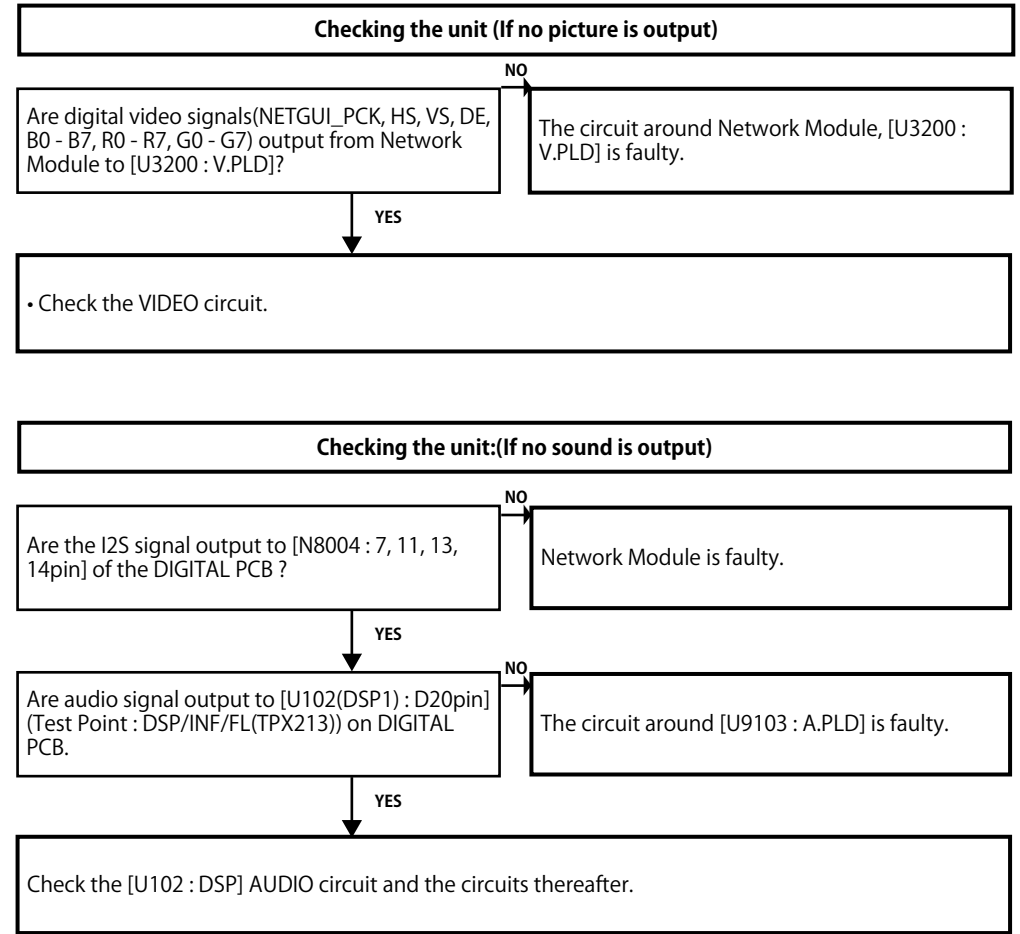

DIGITAL test point

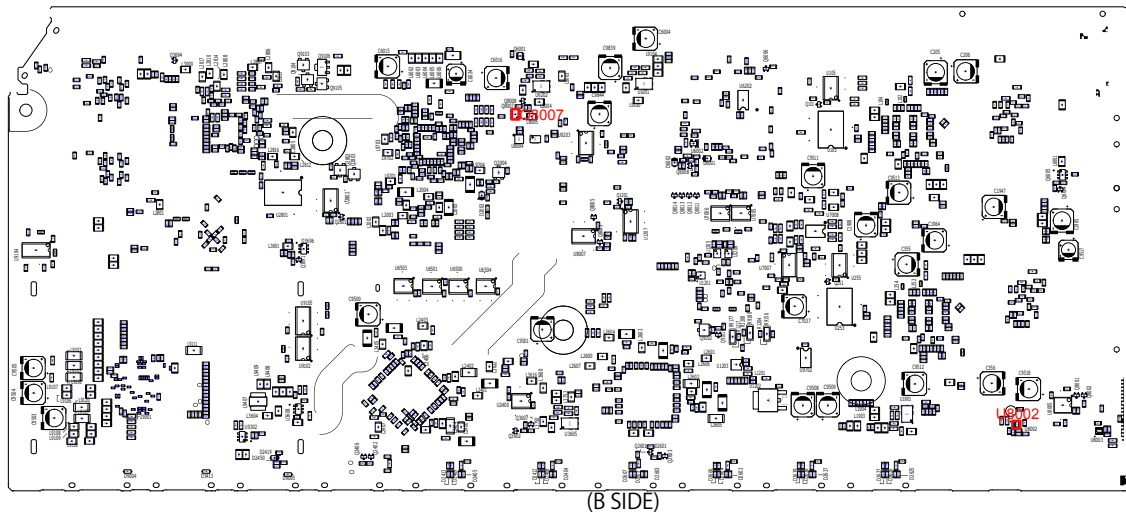
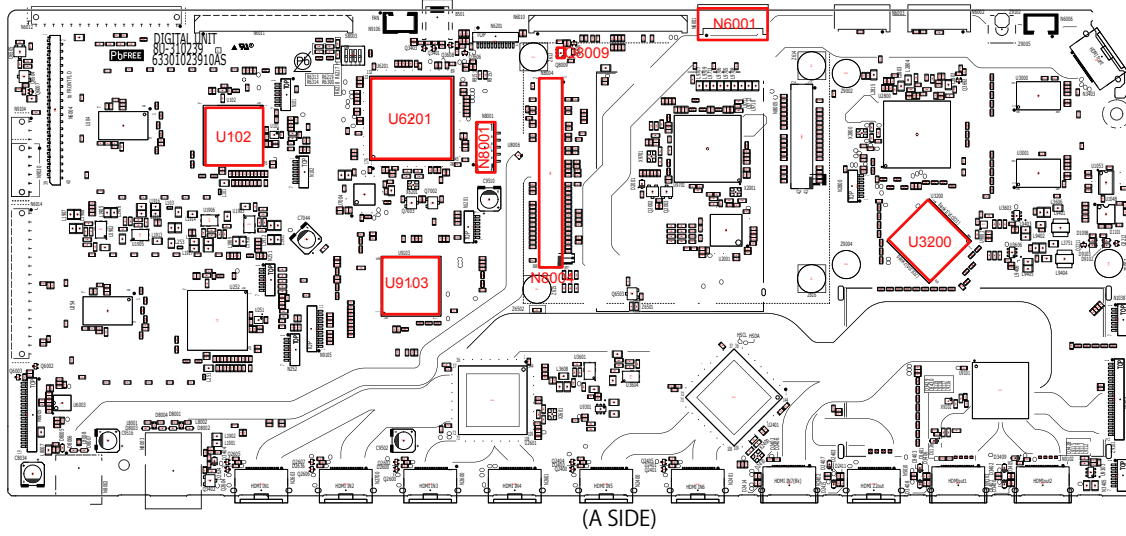

USB test point

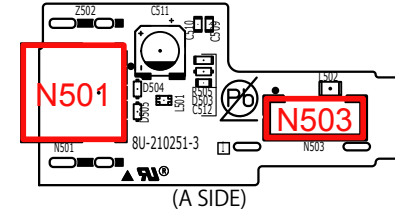

6. SMPS

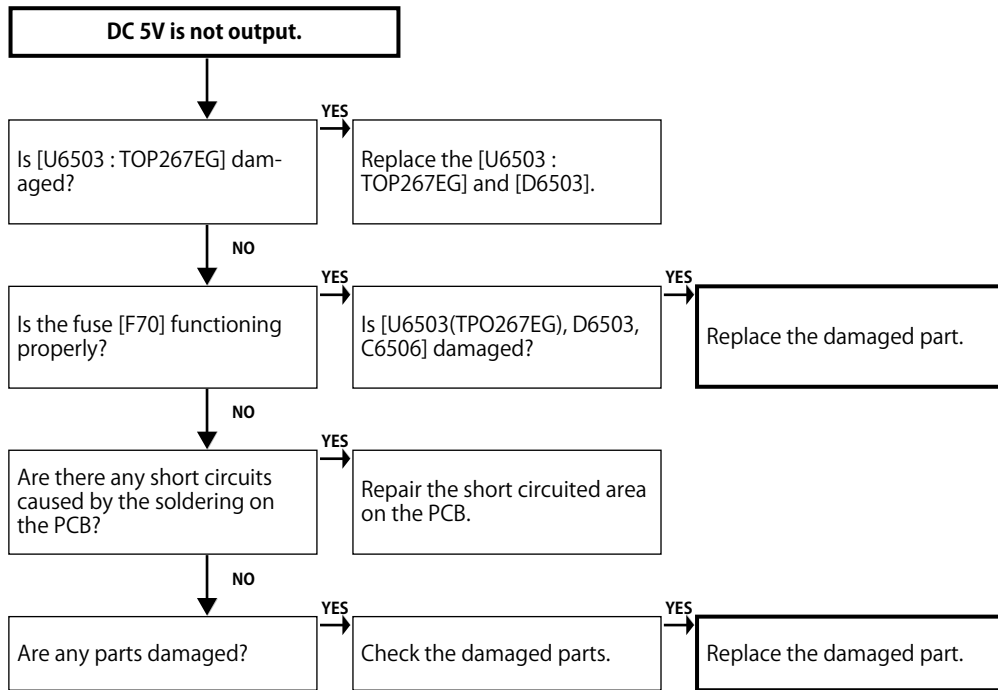

Operation waveform for each part

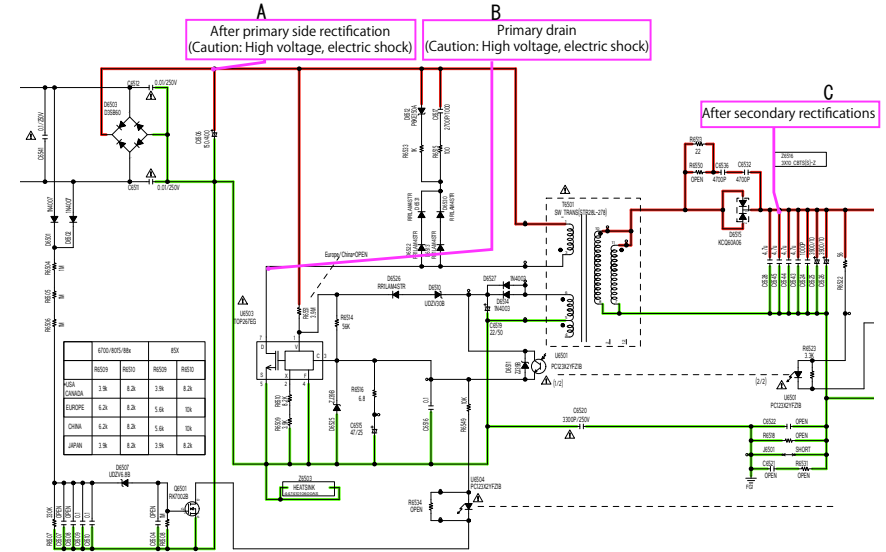

SMPS unit (Unloaded)

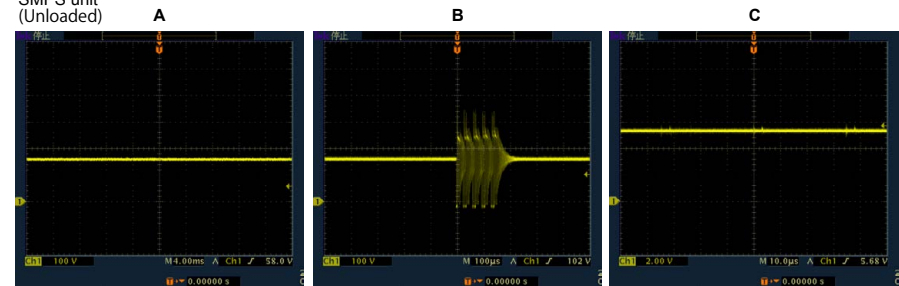

Set

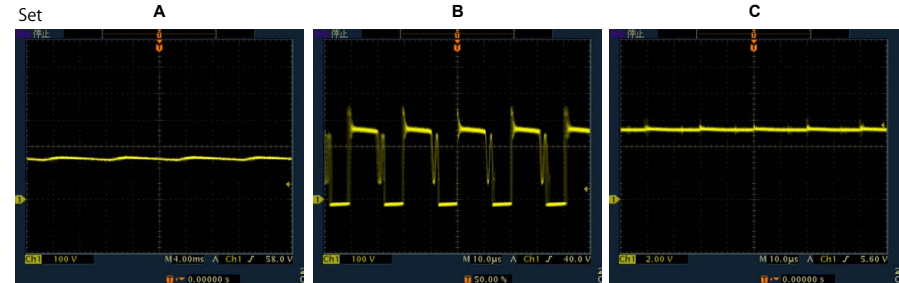

Before Servicing
This Unit

Electrical

Mechanical

Repair Information

Updating

AVR/AVC-X6700H/SR8015 PROTECTION DIAGRAM

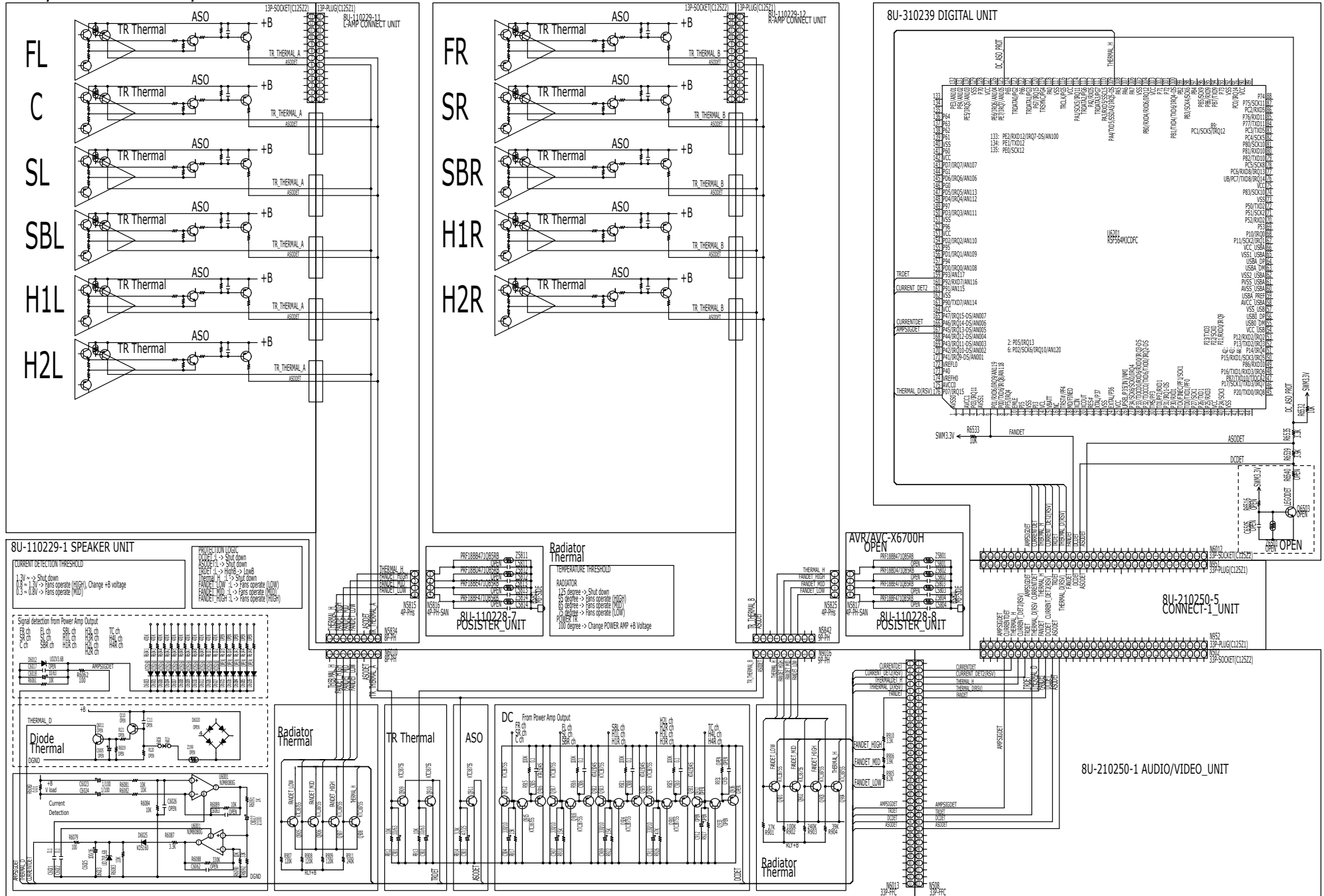

Before Servicing
This Unit

Electrical

Mechanical

Repair Information

Updating

AUDIO CHECK PATH

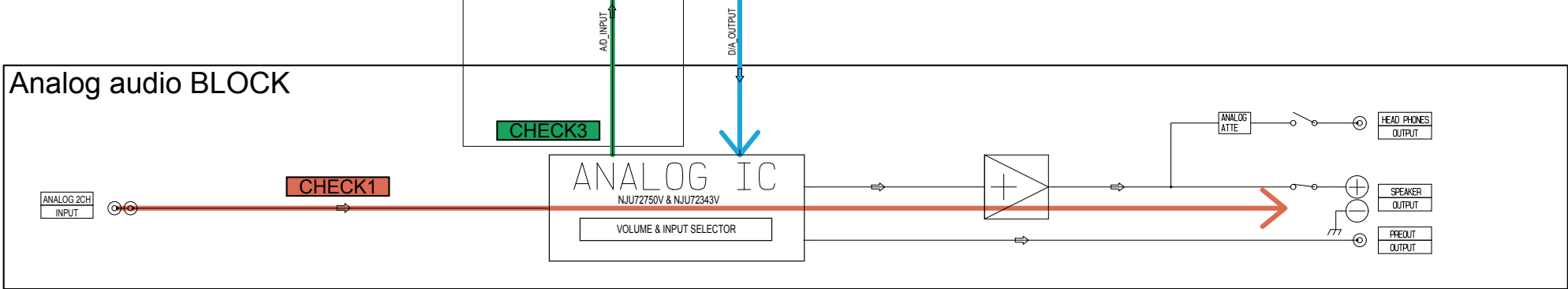
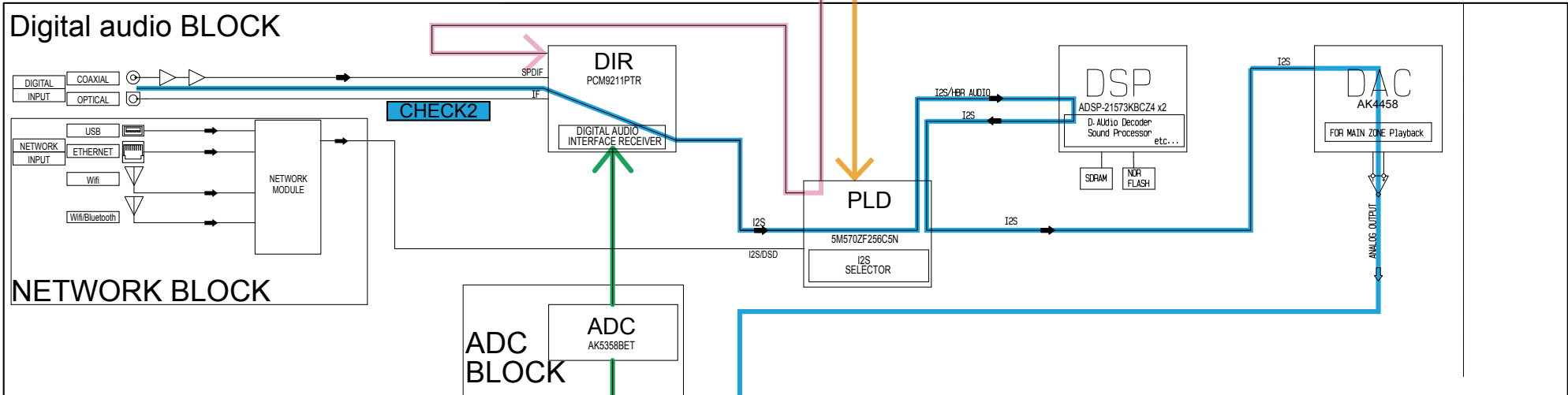
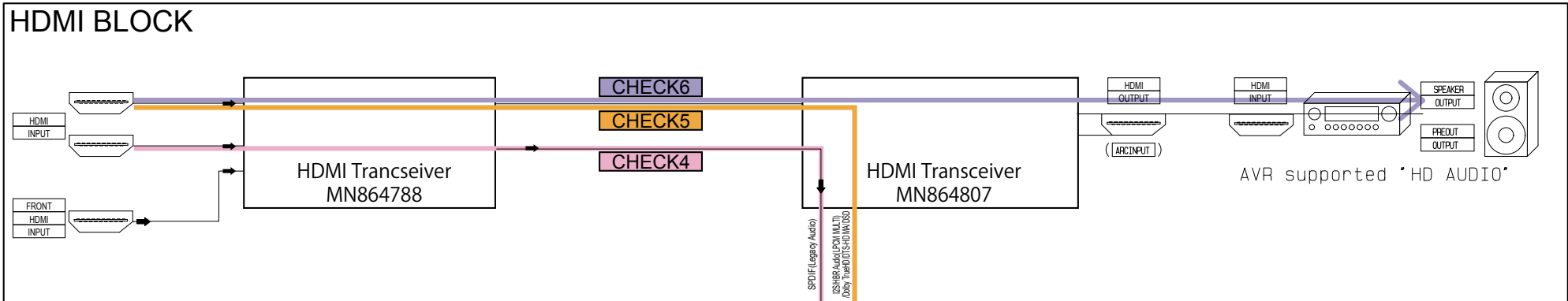
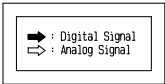

Before Servicing This Unit

Electrical

Mechanical

Repair Information

Updating

HDMI "Rx/Tx" Failure Detection

1. Prior checking

Check item(1.): Checking the HDMI connector
Checking the condition of the HDMI pin (rear/front).

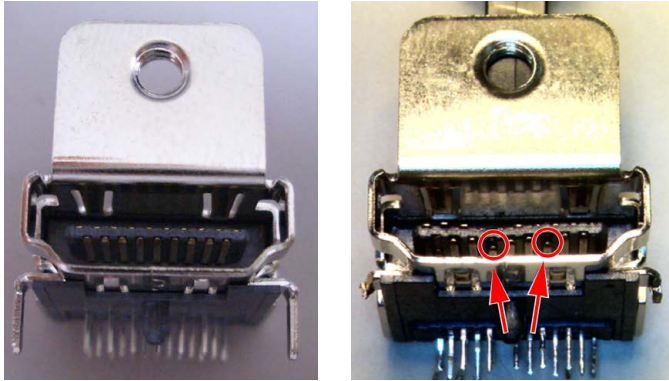

OK

NG

Check for deformed pins.

None of the pins are deformed.

There are deformed pins.

Replace the HDMI connector.

Check by following the flow chart for "3. Starting detecting the point of failure".

NOTE :

After checking troubleshooting "3. HDMI/DVI", check "3. Starting detecting the point of failure".

2. Preparations for checking HDMI Switcher reception/transmission register

2-1. Necessary devices

- 1) Check the product settings.
- 2-a) Player with an HDMI terminal
- 2-b) TV with an HDMI terminal (* NOTE : Do not use a computer monitor.)
- 3) Windows PC
- 4) Serial communication software "Termite.exe"
(Download the software from http://www.compuphase.com/software_termite.htm and install it.)
- 5) HDMI cable
- 6) RS-232C Straight cable
- 7) oscilloscope

2-2. Device Connection Method

Connect the TV and the AVR to the player using an HDMI cable and connect the AVR to the PC through an RS-232C cable as shown in Figure 1.

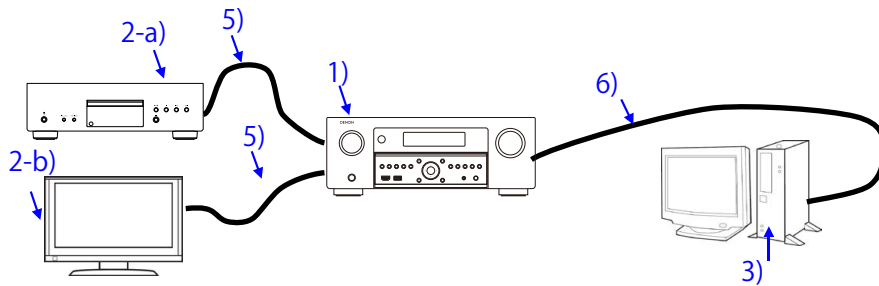

Figure 1. Device Connection Method

2-3. Device configuration method

PC settings : Execute the serial communication program, Termite.exe.

After executing Termite.exe, click [Settings].

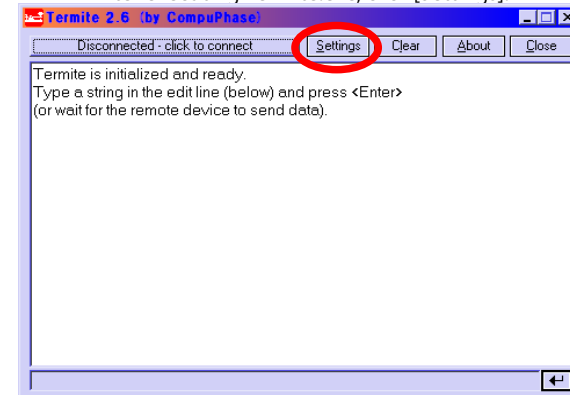

Figure 2. Screen After Executing Termite.exe

The serial port setup screen will be displayed.

Configure the settings as shown in Figure 3 and click the "OK" button.

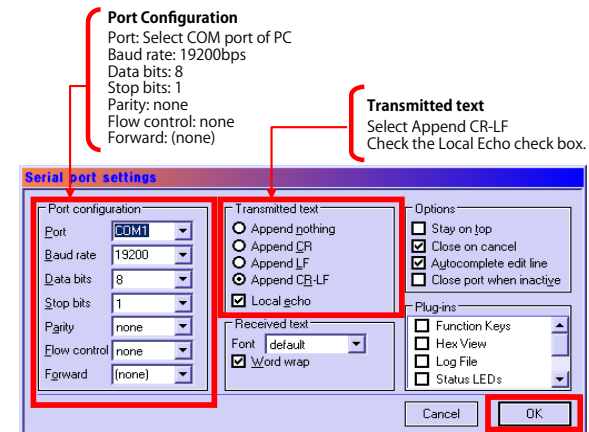

Figure 3. Serial Port Setup Screen

Click the [click to connect] button to start communication.
 After a connection is established successfully, the display of the button name will change as shown in Figure 4.

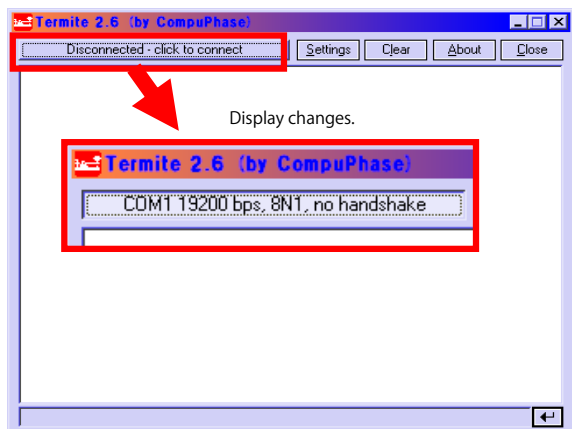

Figure 4. Change of the Display of the Communication Start Button Name

TV settings : Switch to the HDMI input in the AVR connection.
 Player settings : Turn the unit power on and configure it to play disks.
 AVR settings : While the power is On, hold down buttons "CURSOR ▼" and "STATUS" for at least 3 seconds.
 (Press and hold until the two indicator lights at the bottom right of the FLD blink.)
 ※ When the power is turned on after initialization, "Setup Assistant" will be displayed.
 After exiting "Setup Assistant" execute the above.

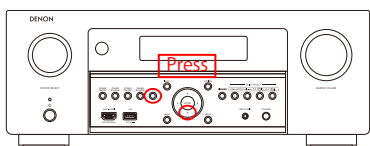

Figure 6. AVR settings

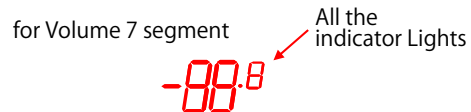

Figure 6. FLD Display When Set

When the settings are correct, the following message will be displayed in the window of Termite.
 [00]Start Sub CPU Log Mode

 (**** is a version of Sub CPU.)

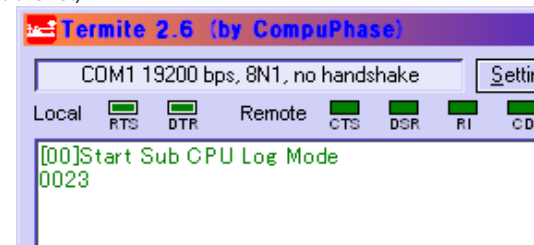

Figure 7. Display of Termite When AVR is Set

The setup is now complete.

Method for sending commands

Enter the command in the transmission command entry section, click the [Send] button and send the command.

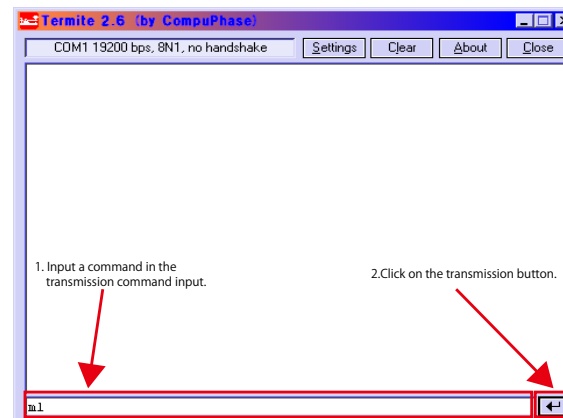

Figure 8. Method for Sending Termite Commands

3. Starting detecting the point of failure

Check item(3.1).

Check the power supply status and communication status with the CPU of each device.
Start in HDMI Diagnostics mode and follow the procedures below.

Start in HDMI Diagnostics mode

While the power is on, hold down buttons "CURSOR ▲" and "BACK" for at least 3 seconds.

L1	HDMI DIAGNOSTICS
L2	

↓ "HDMI DIAGNOSTICS" is displayed.

When the mode has switched, start Hardware Check.

L1	HDMI DIAGNOSTICS
L2	HardwareCheck...



Display when an Error is detected.

L1	Err: H1-01
L2	Contact support

L2 : Content of the display is scrolled.

Check the Error Code table items.

Error Code table

Error Code	Check item No.	Description
H1-01	Check item (3-1.1)	Communication Error with HDMI Tx [U9101 : MN864807]
H1-02	Check item (3-2.1)	Communication Error with HDMI SW1 [U2401 : MN864788]
H1-03	Check item (3-3.1)	Communication Error with HDMI SW2 [U2601 : MN864788]
H1-05	Check item (3-7.1)	Communication Error with VIDEO DECODER [U2001 : ADV7180]
H1-06	Check item (3-4.1)	Communication Error with GUI IC [U2800 : ADV8003]
H1-08	Check item (3-8.1)	Communication Error with DSP1 [U102 : ADSP21573KBC]
H1-09	Check item (3-9.1)	Communication Error with DSP2 [U252 : ADSP21573KBC]
H1-12	Check item (3-10.1)	Communication Error with DIR [U7004 : PCM9211]
H1-14	Check item (3-5.1)	DDR check Error [U3000, U3001 : A3R12E40DBF-8E]
H1-15	Check item (3-6.1)	Communication Error with GUI ROM [U2801 : MX25L12835FM]

Display when an Error is not detected.

L1	HDMI DIAGNOSTICS
L2	1 Auto Test

Cancel the mode, and proceed to [check item \(3.2\)](#).

Canceling the selected mode

Press the power button to exit off the power.

Check item(3.2). : Does a video signal come from HDMI ZONE2 OUT to TV correctly?

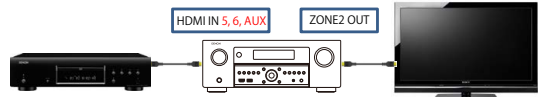

When the HDMI input terminal (HDMI5, 6, AUX) are connected in order to the player, are the audio and video from the player played back on the TV correctly in each case?

YES

Check item(3.3). : Does a video signal come from HDMI ZONE2 OUT to TV correctly?

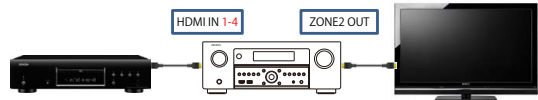

When the HDMI input terminal (HDMI 1, 2, 3, 4) are connected in order to the player, are the audio and video from the player played back on the TV correctly in each case?

YES

NO
Go to **check item (3-11.1).**
(Switcher1 failure detection procedure)

NO
Go to **check item (3-12.1).**
(Switcher2 failure detection procedure)

Check item(3.4). Does a video signal come from HDMI OUT to TV correctly?

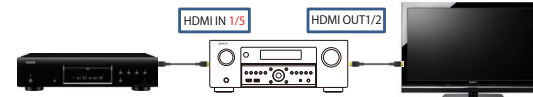

Turn Video Conversion "OFF" on the setup menu.
(SETUP MENU - Video - Output Settings - Video Conversion = Off)
When the player is connected in order to the HDMI input terminals (HDMI1, 5), in each case is the player video played back on the TV connected to the HDMI output terminal (HDMI OUT1, 2)?

YES

When the HDMI input terminal (HDMI IN7) is connected to the player, the video from the player will be played back on the TV?
Use any of Dolby TrueHD/DTS HD MA/PCM 8ch for the playback audio format.

NO

Is the "DIG" indicator illuminated on the FLD?
When the "DIG" indicator is illuminated, the DIGITAL AUDIO block is faulty.
If the "DIG" indicator is not illuminated, go to **check item (3-14.1).**
(HDMI IN7 failure detection procedure)

YES

Check item(3.5). Does a video signal come from HDMI OUT to TV correctly?

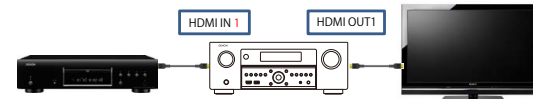

Turn Video Conversion "ON" on the setup menu.
(SETUP MENU - Video - Output Settings - Video Conversion = On)
When the HDMI input terminal (HDMI 1) is connected to the player, the video from the player will be played back on the TV?

YES

There are no problems with the HDMI device.

NO
Go to **check item (3-13.1).**
(Tx failure detection procedure)

NO
Go to **check item (3-15.1).**
(GUI and PLD failure detection procedure)

3-1. Error Code H1-01 failure detection procedure

Checking device. [U9101 : MN864807]

Check the power supply voltage. (HDMI Tx)

Check item(3-1.1). Check the power supply voltage. :
Does the power supply voltage of the HDMI Tx [U9101] indicate the correct voltage (0.9V x2, 1.8V, 3.3V)?
The test points are as follows.

HDMI Tx

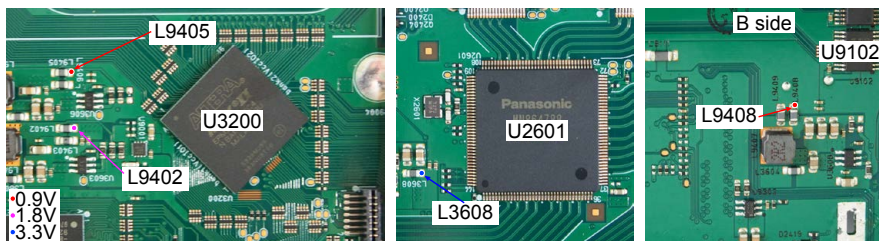

YES

NO

Check item(3-1.2). Check the power supply voltage. :
Check the power components [U3606/U3608/U3603/U3601] and the pattern on the substrate.
If there is no problem, remove the HDMI Tx [U9101] from the substrate and measure the voltage at the test point of **check item (3-1.1)**.
Is the voltage correct (0.9V x2, 1.8V, 3.3)?

YES

NO

Replace with a new device.

The power supply circuit is faulty.
Replace the PCB.

Recheck from **check item (3.1)**.
If it does not work, replace the PCB.

Checking the reset waveform. (HDMI Tx)

Check item(3-1.3). Checking the reset waveform :
Check the waveform.
Is the "RST" waveform of the TP near the CPU [U6201] correct (like the one shown in the diagram) when the power is turned on?

HDMI Tx

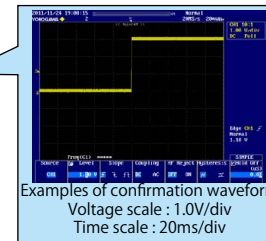
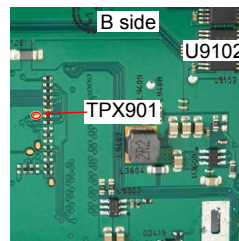

NO

Check the reset circuit between CPU [U6201] and HDMI Tx [U9101].
If there is no problem, the HDMI Tx [U9101] is faulty.
Replace with a new device.
Recheck from **check item (3.1)**.
If it does not work, replace the PCB.

YES

Go to next page.

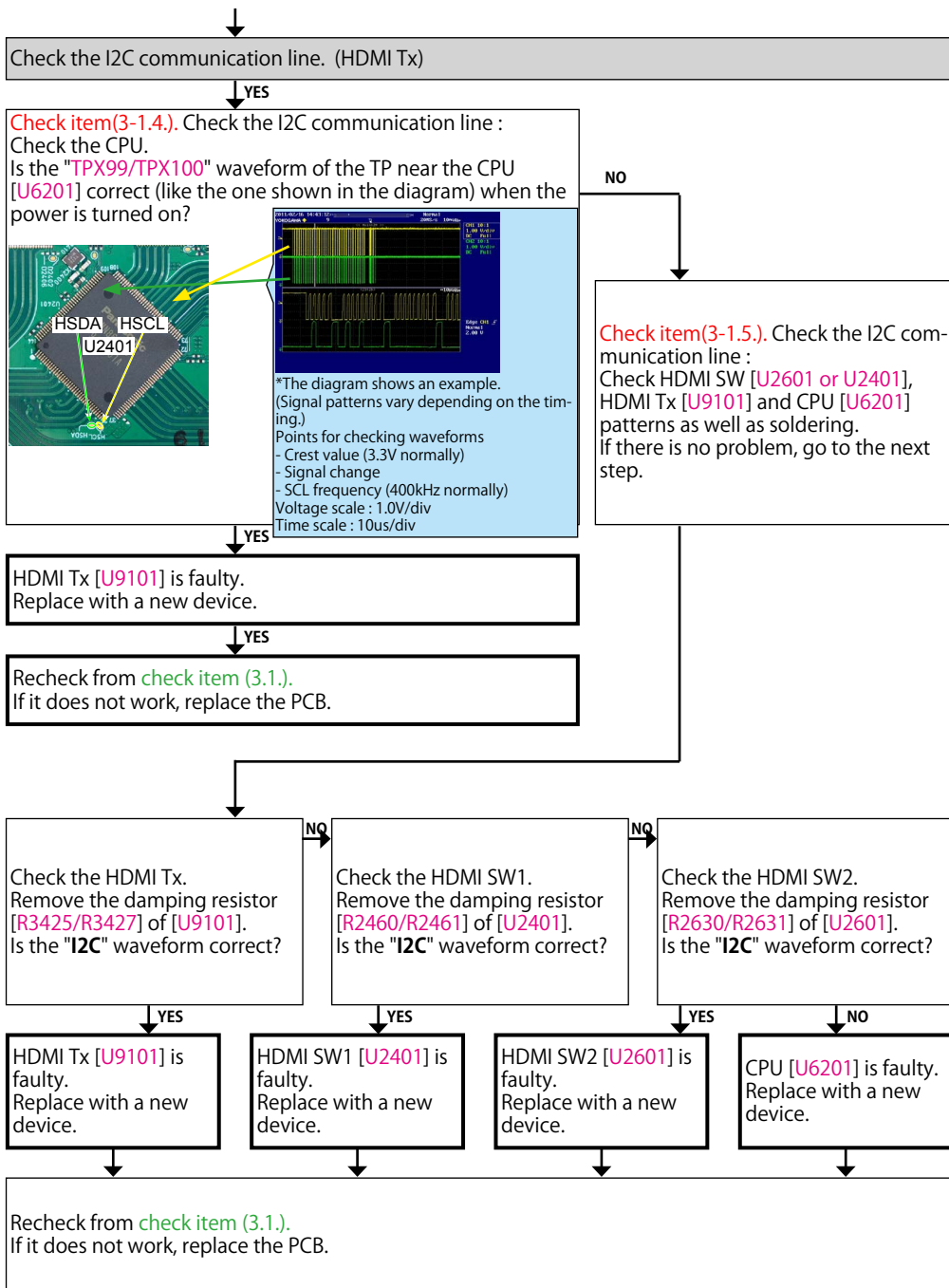

3-2. Error Code H1-02 failure detection procedure

Checking device. [U2401 : MN864788]

Check the power supply voltage. (HDMI SW1)

Check item(3-2.1). Check the power supply voltage. :
Does the power supply voltage of the HDMI SW1 [U2401] indicate the correct voltage (1.1V)?
The test points are as follows.

HDMI SW1

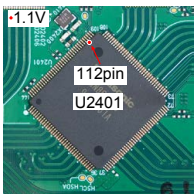

YES

NO

Check item(3-2.2). Check the power supply voltage. :
Check the power components (U3604) and the pattern on the substrate.
If there is no problem, remove the HDMI SW1 [U2401] from the substrate and measure the voltage at the test point of **check item (3-2.1)**.
Is the power supply voltage correct (1.1V)?

YES

NO

Replace with a new device.

The power supply circuit is faulty.
Replace the PCB.

Recheck from **check item (3.1)**.
If it does not work, replace the PCB.

Checking the reset waveform. (HDMI SW1)

Check item(3-2.3). Checking the reset waveform :
Check the waveform.
Is the "TPX25" waveform of the TP near the HDMI SW1 [U2401] correct (like the one shown in the diagram) when the power is turned on?

HDMI SW1

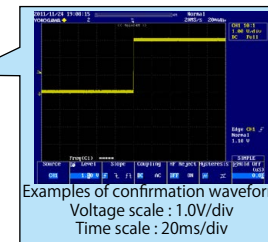
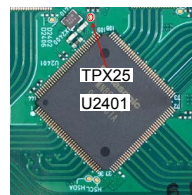

NO

Check the reset circuit between CPU [U6201] and HDMI SW1 [U2401].
If there is no problem, the HDMI SW1 [U2401] is faulty.
Replace with a new device.

YES

check item (3.1) again after replacing [R2460/R2461] with a new resistor.
If there is still a problem, the HDMI SW1 [U2401] is faulty.
Replace with a new device.

Recheck from **check item (3.1)**.
If it does not work, replace the PCB.

3-3. Error Code H1-03 failure detection procedure

Checking device. [U2601 : MN864788]

Check the power supply voltage. (HDMI SW2)

Check item(3-3.1). Check the power supply voltage. :
Does the power supply voltage of the HDMI SW2 [U2601] indicate the correct voltage (1.1V)?
The test points are as follows.
HDMI SW2

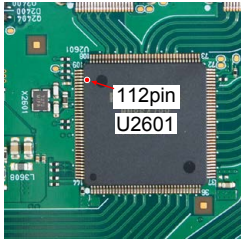

YES → NO

Check item(3-3.2). Check the power supply voltage. :
Check the power components [U3605] and the pattern on the substrate.
If there is no problem, remove the HDMI SW2 [U2601] from the substrate and measure the voltage at the test point of **check item (3-3.1)**.
Is the power supply voltage correct (1.1V)?

YES → NO
 YES: Replace with a new device.
 NO: The power supply circuit is faulty. Replace the PCB.

Recheck from **check item (3.1)**.
If it does not work, replace the PCB.

Checking the reset waveform. (HDMI SW2)

Check item(3-3.3). Checking the reset waveform :
Check the waveform.
Is the "TPX915" waveform of the TP near the HDMI SW2 [U2601] correct (like the one shown in the diagram) when the power is turned on?

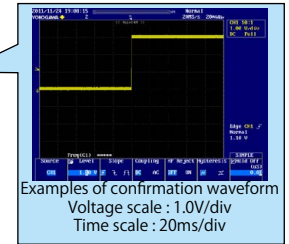
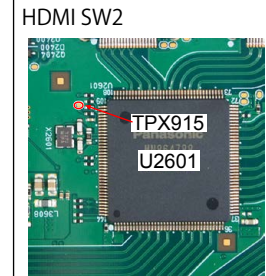

HDMI SW2

YES → NO
check item (3.1) again after replacing [R2630/R2631] with a new resistor.
If there is still a problem, the HDMI SW2 [U2601] is faulty. Replace with a new device.

NO →
 Check the reset circuit between CPU [U6201] and HDMI SW2 [U2601].
If there is no problem, the HDMI SW2 [U2601] is faulty. Replace with a new device.
Recheck from **check item (3-3.3)**.
If it does not work, replace the PCB.

Recheck from **check item (3.1)**.
If it does not work, replace the PCB.

3-4. Error Code H1-06 failure detection procedure

Checking device. [U2800 : ADV8003]

Check the power supply voltage.

Check item(3-4.1). Check the power supply voltage. :
Does the power supply voltage of the GUI [U2800] indicate the appropriate voltage (1.8V, 3.3V)?
The test points are as follows.

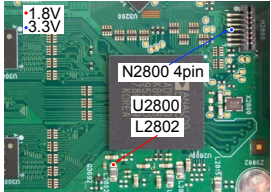

Check item(3-4.2). Check the power supply voltage. :
Check the power supply components [U9001/ Q3696] on the substrate and peripheral pattern.
If there is no problem, remove the GUI [U2800] from the substrate and measure the voltage at the test point of **check item (3-4.1)**.
Is the voltage correct (1.8V or 3.3V)?

YES

YES

NO

The power supply circuit is faulty.
Replace the PCB.

GUI [U2800] is faulty.
Replace with a new device.

Recheck from **check item (3.1)**.
If it does not work, replace the PCB.

Checking the reset waveform.

Check item(3-4.3). Checking the reset :
Check the CPU.
Is the waveform of the TP near the GUI [U2800] correct (like the one shown in the diagram) when the power is turned on?

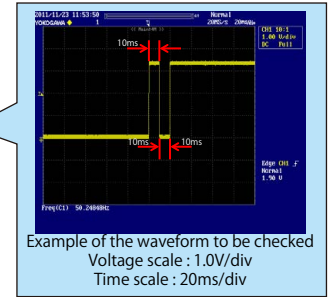
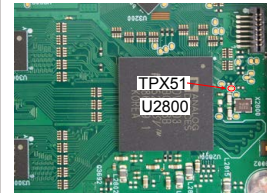

YES

NO

Check the reset circuit between CPU [U6201] and GUI [U2800].
If there is no problem, the GUI [U2800] is faulty.
Replace with a new device.

Recheck from **check item (3.1)**.
If it does not work, replace the PCB.

Go to next page.

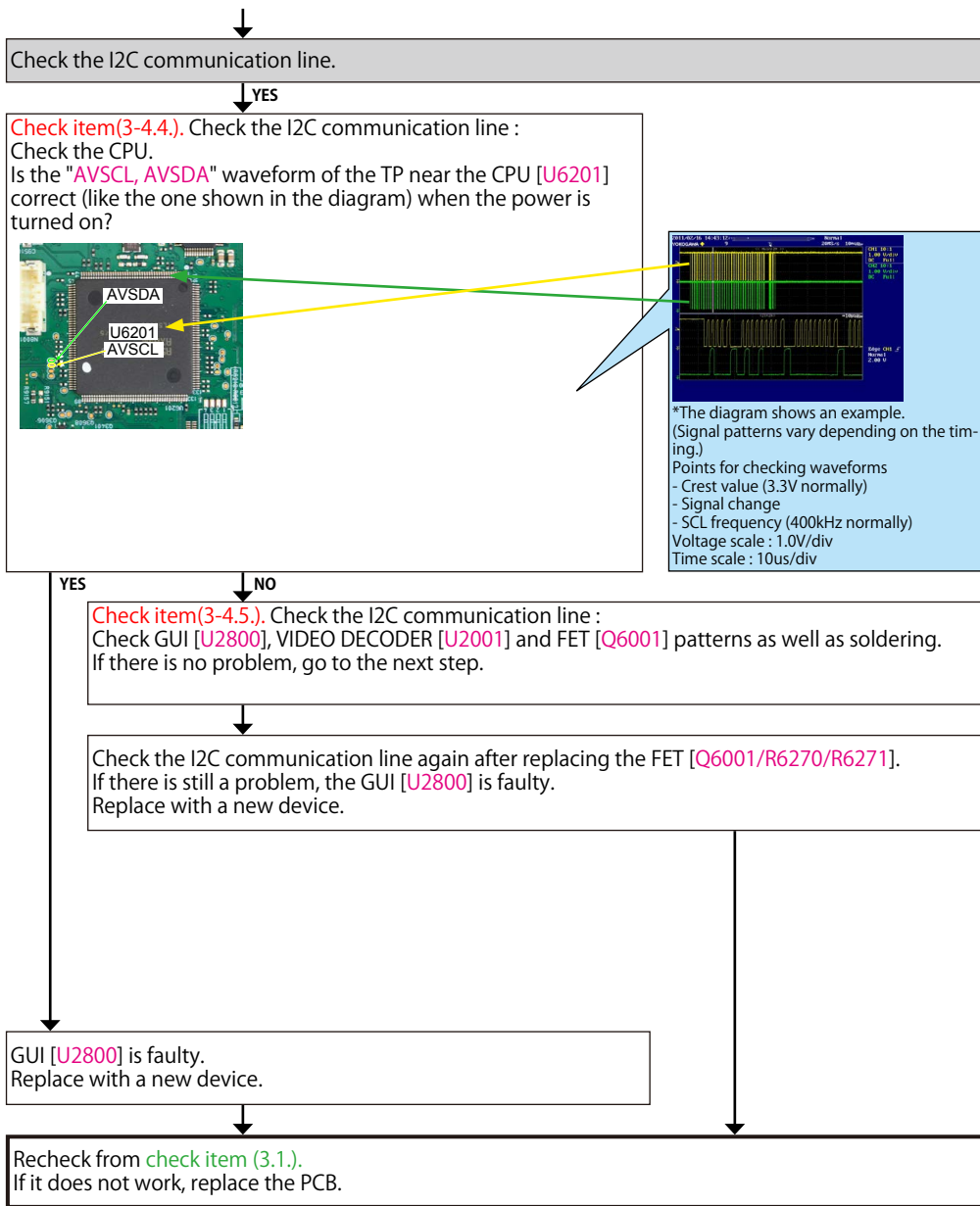

3-5. Error Code H1-14 failure detection procedure

Checking device. [U3000, U3001 : A3R12E40DBF-8E]

Check item(3-5.1).
Check soldering of IP SCALER [U2800], DDR2 [U3000/U3001] and its peripheral circuits.
Check soldering of the resistors [R2821 to R2843] between IP SCALER and DDR2.
If there is no problem with soldering, [U2800/U3000/U3001] is defective. Replace their IC. Or replace the substrate.

Recheck from **check item (3.1).**

3-6. Error Code H1-15 failure detection procedure

Checking device. [U2801 : MX25L12835FMI]

Check item(3-6.1).
Write to the GUI ROM.
Recheck from **check item (3.1).**
Does Error Code H1-15 continue?

Check item(3-6.2).
Replace [U3001] with a new device.
Recheck from **check item (3.1).**
Does Error Code H1-15 continue?

Go to **check item (3-4.1).**

Recheck from **check item (3.2).**

3-7. Error Code H1-05 failure detection procedure

Checking device. [U2001 : ADV7180]

Checking the reset waveform. (VIDEO DECODER)

Check item(3-7.1.). Checking the reset waveform :
Check the waveform.
Is the "R6295" waveform of the TP near the VIDEO DECODER [U2001] correct (like the one shown in the diagram) when the power is turned on?
VIDEO DECODER

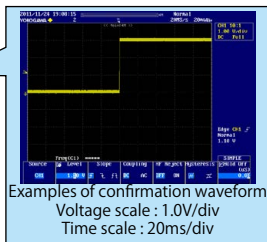
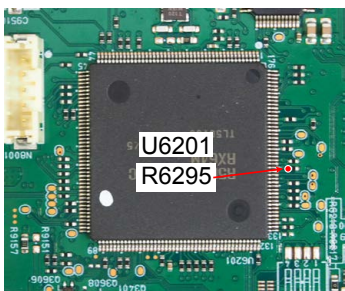

NO
Check the reset circuit between CPU [U6201] and VIDEO DECODER [U2001].
If there is no problem, the VIDEO DECODER [U2001] is faulty.
Replace with a new device.
Recheck from check item (3-7.1.)
If it does not work, replace the PCB.

YES

check item (3.1.) again after replacing [R2033/R2034/R9764/R9765] with a new resistor.
If there is still a problem, the VIDEO DECODER [U2001] is faulty.
Replace with a new device.

Recheck from check item (3.1.).
If it does not work, replace the PCB.

3-8. Error Code H1-08 failure detection procedure

Checking device. (DSP1) [U102 : ADSP21573KBC]

Check the power supply voltage. (DSP1)

Check item(3-8.1). Check the power supply voltage.:
Does the power supply voltage of the DSP [U102] indicate the appropriate voltage (1.1V, 1.5V, 3.3V)?
The test points are as follows.

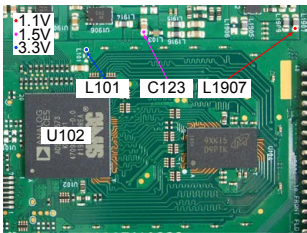

Check item(3-8.2). Check the power supply voltage.:
Check the power supply components [U1902/ U1905/U1901] on the substrate and peripheral pattern.
If there is no problem, remove the DSP [U102] from the substrate and measure the voltage at the test point of **check item (3-8.1)**.
Is the voltage correct (1.1V, 1.5V, 3.3V)?

Checking the reset waveform. (DSP1)

Check item(3-8.3). Checking the reset :
Check the CPU.
Is the "TPX112" waveform of the TP near the CPU [U6201] correct (like the one shown in the diagram) when the power is turned on?

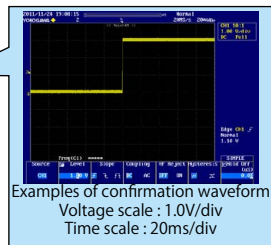
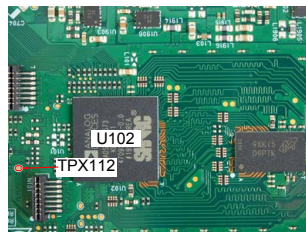

YES

YES

NO

YES

NO

The power supply circuit is faulty.
Replace the PCB.

DSP [U102] is faulty.
Replace with a new device.

Recheck from **check item (3.1)**.
If it does not work, replace the PCB.

Check the reset circuit between CPU [U6201] and DSP [U102].
If there is no problem, the DSP [U102] is faulty.
Replace with a new device.

Recheck from **check item (3.1)**.
If it does not work, replace the PCB.

Go to next page.

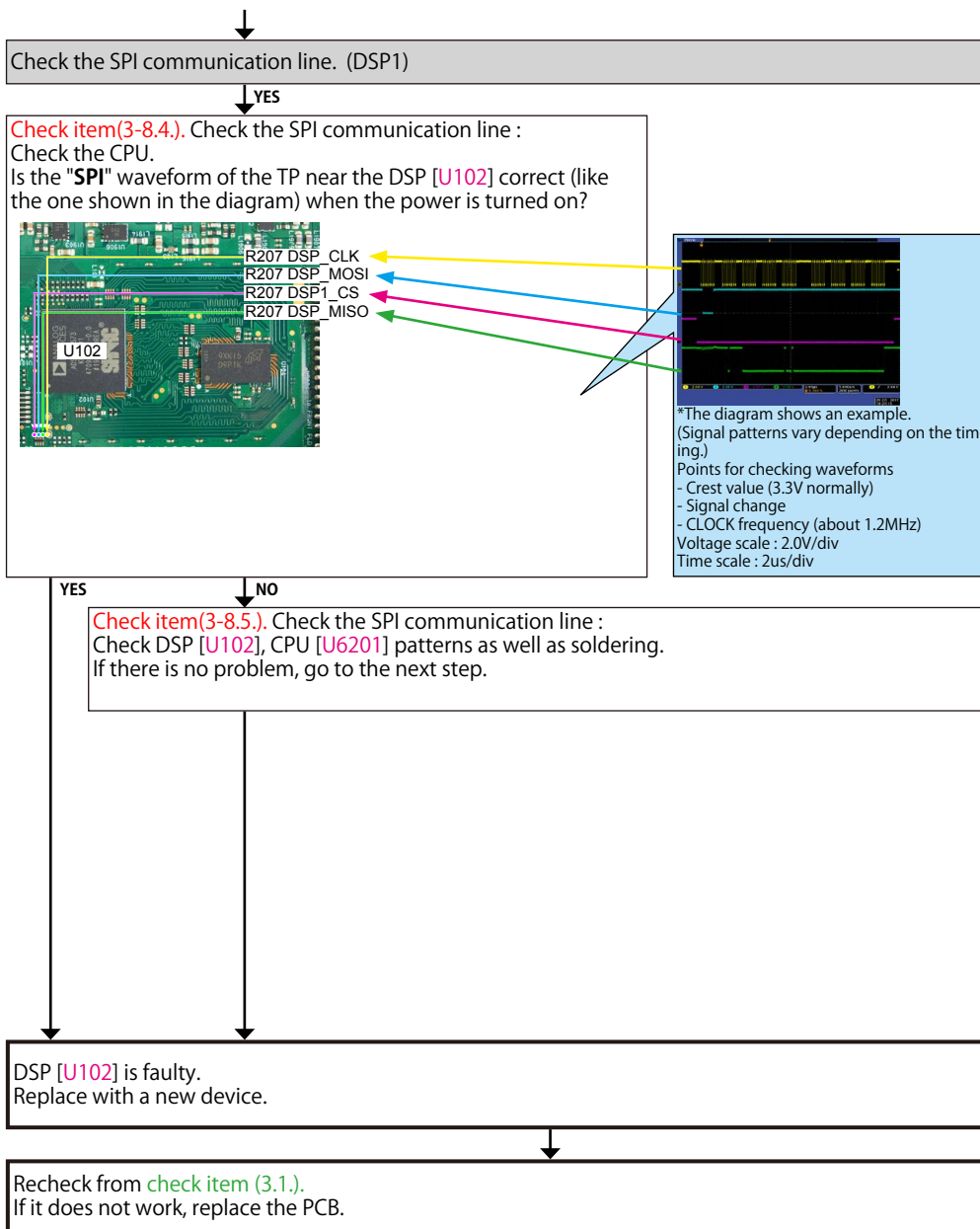

3-9. Error Code H1-09 failure detection procedure

Checking device. (DSP2) [U252 : ADSP21573KBC]

Check the power supply voltage. (DSP2)

Check item(3-9.1). Check the power supply voltage.:
Does the power supply voltage of the DSP [U252] indicate the appropriate voltage (1.1V, 1.5V, 3.3V)?
The test points are as follows.

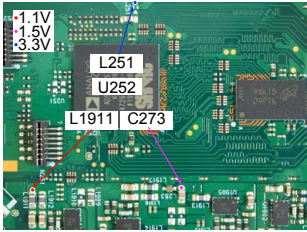

Check item(3-9.2). Check the power supply voltage.:
Check the power supply components [U1903/ U1906/U1901] on the substrate and peripheral pattern.
If there is no problem, remove the DSP [U252] from the substrate and measure the voltage at the test point of **check item (3-8.1)**.
Is the voltage correct (1.1V, 1.5V, 3.3V)?

Checking the reset waveform. (DSP2)

Check item(3-9.3). Checking the reset :
Check the CPU.
Is the "TPX112" waveform of the TP near the CPU [U6201] correct (like the one shown in the diagram) when the power is turned on?

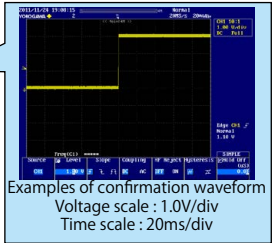
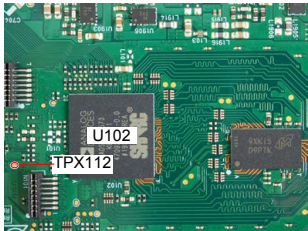

YES

YES

NO

YES

NO

The power supply circuit is faulty.
Replace the PCB.

DSP [U252] is faulty.
Replace with a new device.

Recheck from **check item (3.1)**.
If it does not work, replace the PCB.

Check the reset circuit between CPU [U6201] and DSP [U252].
If there is no problem, the DSP [U252] is faulty.
Replace with a new device.

Recheck from **check item (3.1)**.
If it does not work, replace the PCB.

Go to next page.

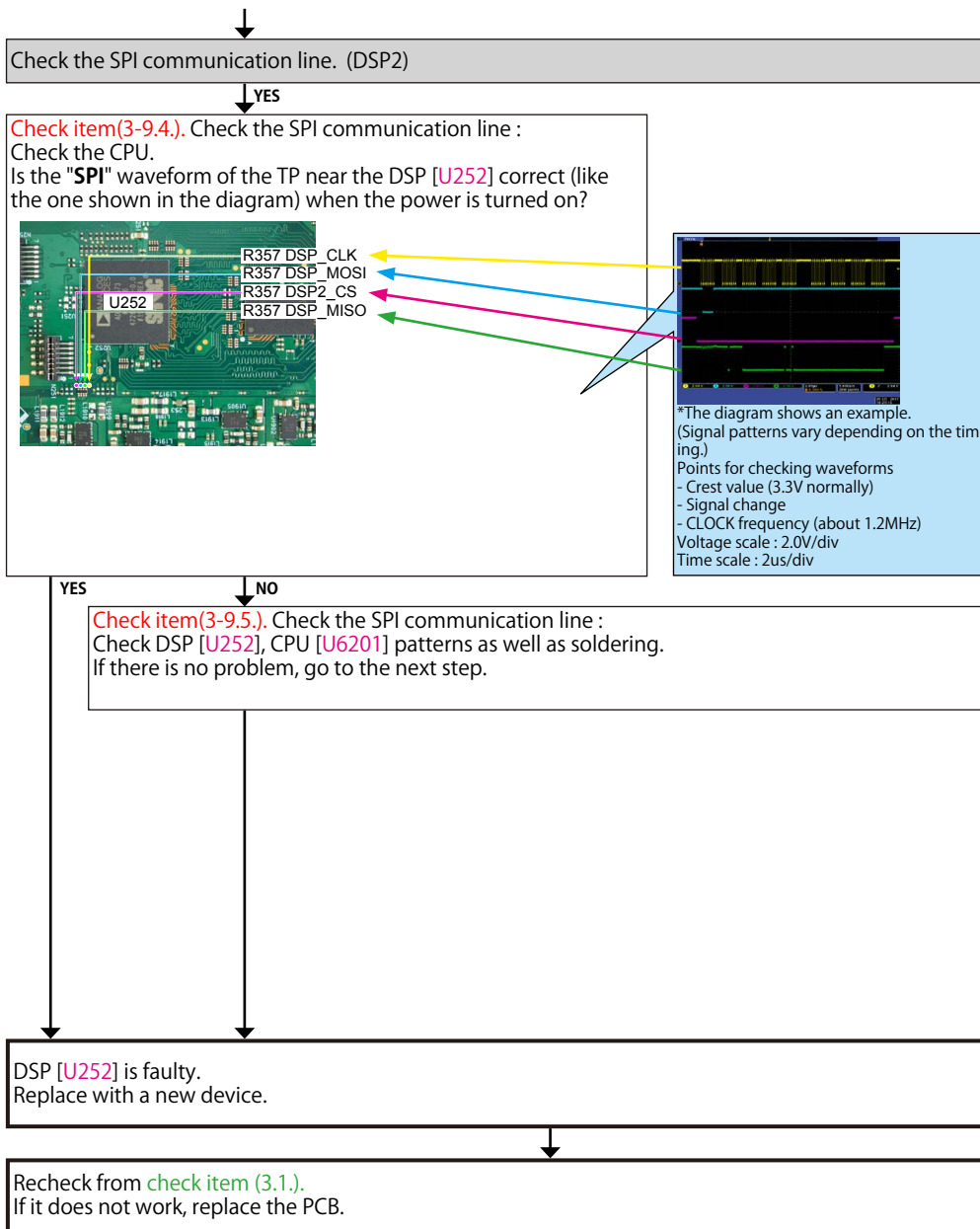

3-10. Error Code H1-12 failure detection procedure

Checking device. [U7004 : PCM9211]

Checking the reset waveform. (DIR)

Check item(3-10.1). Checking the reset :
Check the CPU.

Is the waveform of the TP near the DIR [U7004] correct (like the one shown in the diagram) when the power is turned on?

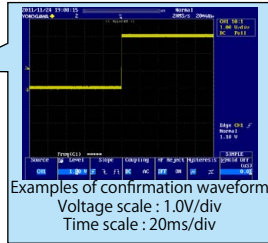
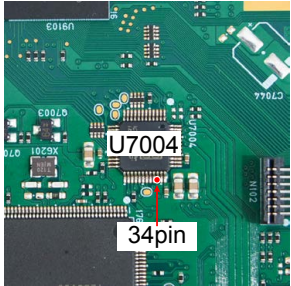

YES

NO

Check the reset circuit between CPU [U6201] and DIR [U7004].
If there is no problem, the DIR [U7004] is faulty.
Replace with a new device.

Recheck from **check item (3.1.)**.
If it does not work, replace the PCB.

Check the communication line. (DIR)

YES

Check item(3-10.2). Check the communication line :
Check the CPU.

Is the waveform of the TP near the DIR [U7004] correct (like the one shown in the diagram) when the power is turned on?

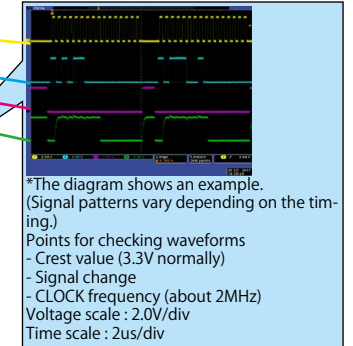
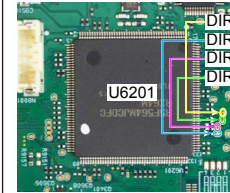

YES

NO

Check item(3-10.3). Check the communication line :
Check DIR [U7004], CPU [U6201] patterns as well as soldering.
If there is no problem, go to the next step.

DIR [U7004] is faulty.
Replace with a new device.

Recheck from **check item (3.1.)**.
If it does not work, replace the PCB.

3-11. Switcher1 failure detection procedure

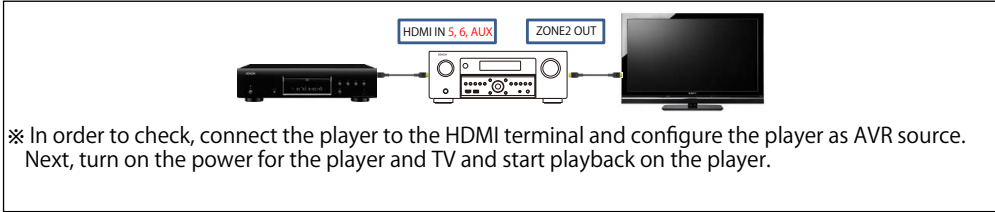

Checking the +5V/DDC status register (HDMI Switcher1)

Check item(3-11.1). Checking the 5V status register :
Send the following command from Termite.exe.

Send the command "i 002E 00FF 0001".

Case of IN5
Is the return value "A2 or A0" ?
(IN6 : "91 or 90", AUX : "C4 or C0")

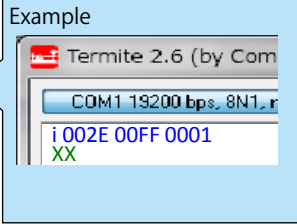

YES

NO

Go to **check item (3-11.3).**

Check item(3-11.2). Checking the DDC status register :
Send the following command from Termite.exe.

Case of IN5
Send the command "i 002B 0054 0001".
Case of IN6
Send the command "i 002B 0024 0001".
Case of AUX
Send the command "i 002B 0084 0001".

Example

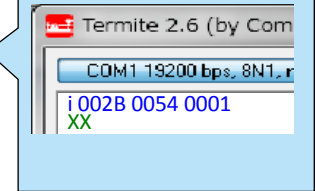

Move to the branch destination according to the value returned.

"00 or 04"
(Detection of DDC is not OK.)

Go to **check item (3-11.4).**

"22 or 11"
(Detection of DDC is OK)

Go to **check item (3-11.5).**

When the results of check item (3-11.1.) are "NO"
(Detection of 5V is not OK)

Check the +5V voltage. (HDMI IN5, 6, AUX)

Check item(3-11.3.). Check the +5V voltage.
Does the test point near HDMI input terminal [N2400/N2401/N3403] indicate 5V?

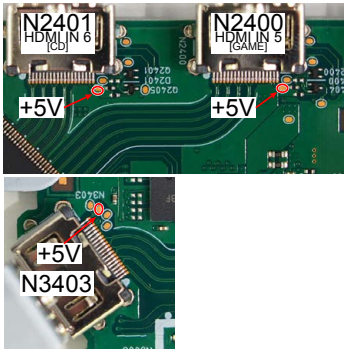

YES

HDMI Switcher1 [U2401] is faulty.
Replace with a new device.

NO

Check for a short circuit in the 5V line and the 5V Switch IC [U2400].
If there is no problem, the HDMI Switcher1 [U2401] or the 5V Switch IC [U2400] is faulty.
Replace with a new device.

Recheck from check item (3.2.).
If it does not work, replace the PCB.

When the results of check item (3-11.2.) are "00 or 04"
(Detection of DDC is not OK.)

Check the DDC line. (HDMI IN5, 6, AUX)

Check item(3-11.4.). Check the DDC line :
Are waveforms of "DDCCL" and "DDCDA" observed at the test point near the HDMI input terminal [N2400/N2401/N3403]?

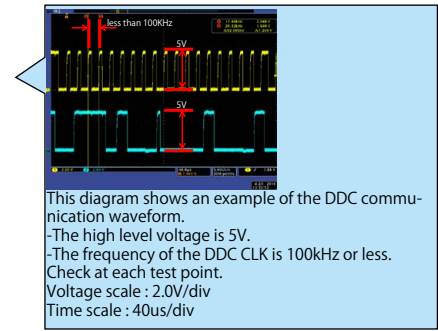
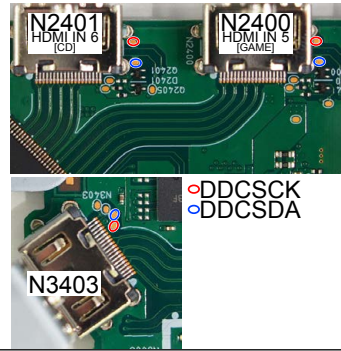

YES

HDMI Switcher1 [U2401] is faulty.
Replace with a new device.

NO

Check for a short circuit in the DDC line.
If there is no problem, the HDMI Switcher1 [U2401] is faulty.
If you are using HDMI AUX IN, TCA9517 [U501] is faulty.
Replace with a new device.

Recheck from check item (3.2.).
If it does not work, replace the PCB.

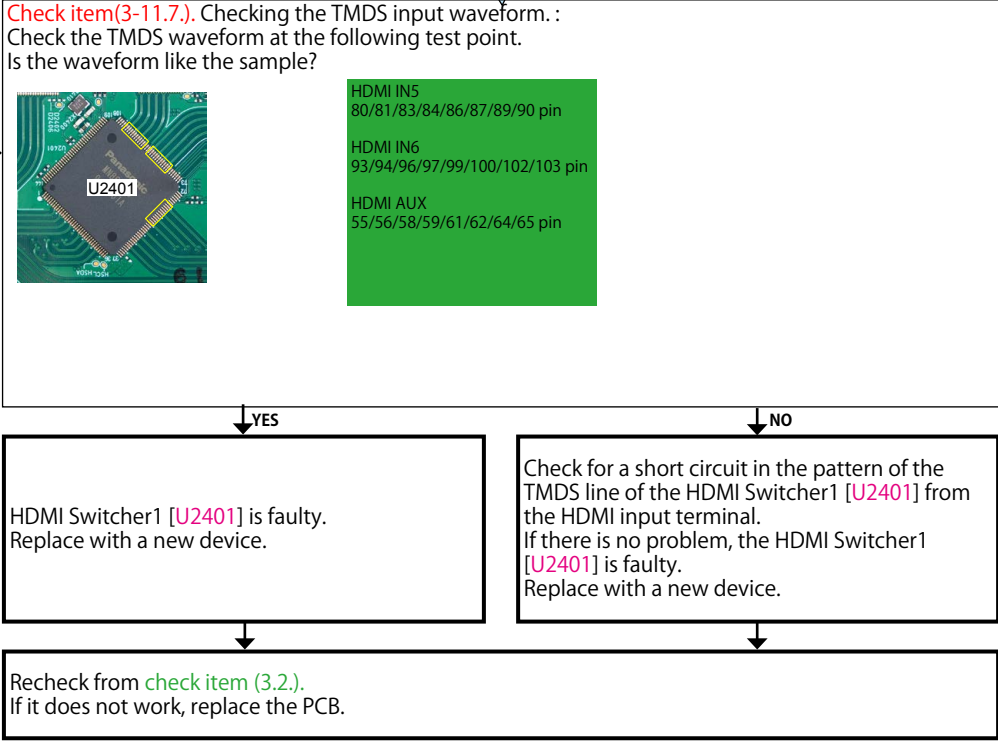
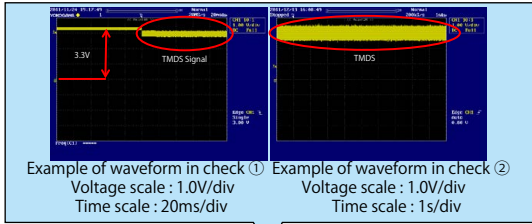
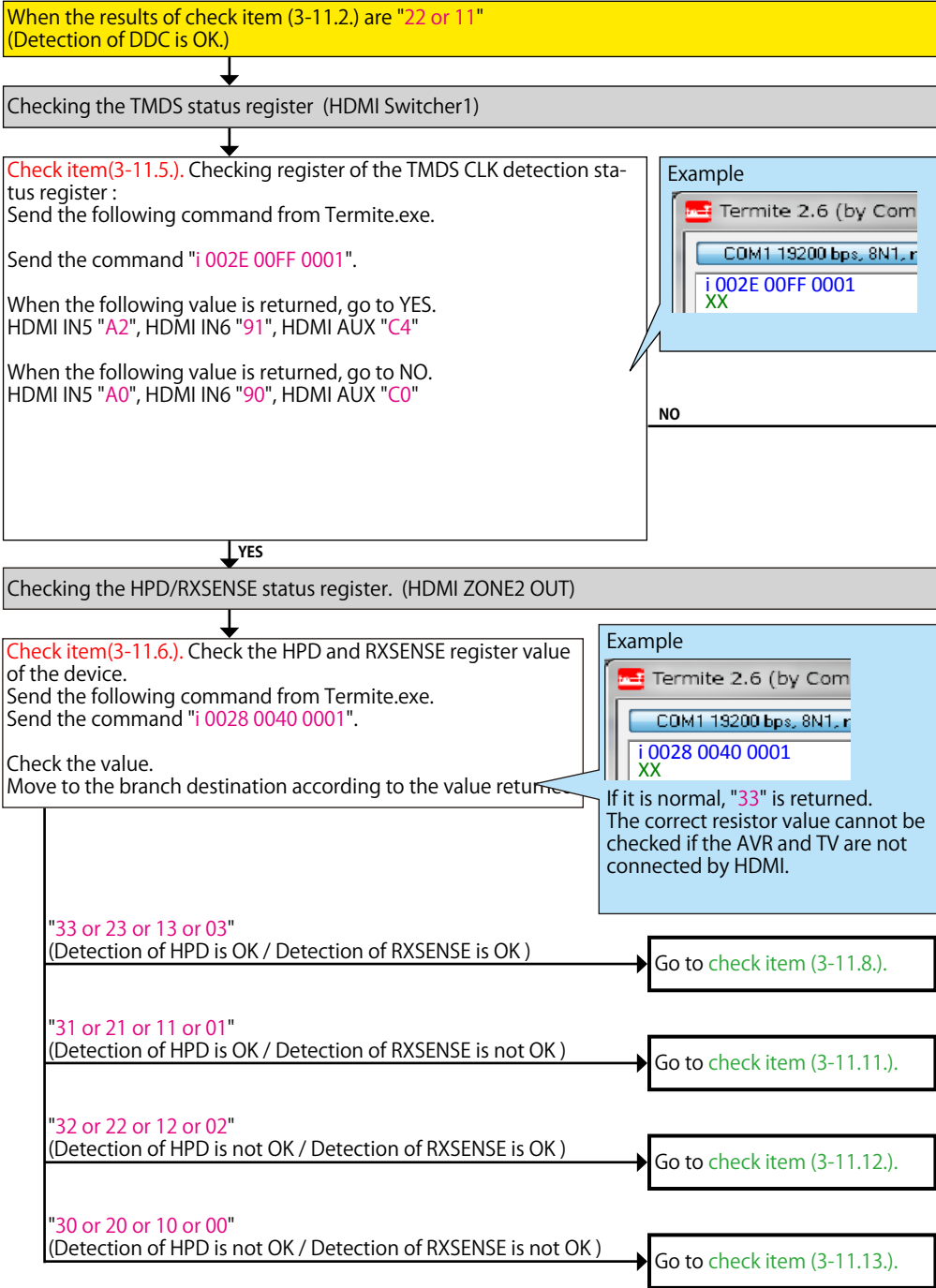

When the results of check item (3-11.6.) are "33 or 23 or 13 or 03"
(Detection of HPD is OK / Detection of RXSENSE is OK)

Checking the EDID register. (HDMI ZONE2 OUT)

Check item(3-11.8). Check the Monitor EDID :
 ① Unplug the AC cord. Plug the AC cord into a power outlet.
 ② Send the transmission command "m_3" from Termite.exe.
 Are the first eight bytes of the returned value "00FFFFFFFFF00"?

Example

The first eight bytes are normally "00FFFFFFFFF00".
 The correct resistor value cannot be checked if the AVR and TV are not connected by HDMI.

YES **NO**

Example of waveform in check ①
 Voltage scale : 1.0V/div
 Time scale : 20ms/div

This diagram shows an example of the DDC communication waveform.
 -The high level voltage is 5V.
 -The frequency of the DDC CLK is 100kHz or less.
 Check at each test point.
 Voltage scale : 2.0V/div
 Time scale : 40us/div

Check item(3-11.9). Checking the TMDS :
 Check the TMDS waveform at the following test point.

Check item(3-11.10). Check the communication :
 Do "DDCSCK" and "DDCSDA" indicate (5V) at the test point near HDMI output connector [N5010]?

YES **NO**

Check for a short circuit in the TMDS line.
 If there is no problem, the HDMI Switcher1 [U2401] is faulty.
 Replace with a new device.

HDMI Switcher1 [U2401] is faulty.
 Replace with a new device.

YES **NO**

Check for a short circuit in the DDC line.
 If there is no problem, the HDMI Switcher1 [U2401] is faulty.
 Replace with a new device.

HDMI Switcher1 [U2401] is faulty.
 Replace with a new device.

Recheck from **check item (3.2.)**.
 If it does not work, replace the PCB.

When the results of check item (3-11.6.) are "31 or 21 or 11 or 01"
(Detection of HPD is OK / Detection of RXSENSE is not OK)

Check the TMDS. (HDMI ZONE2 OUT)

Check item(3-11.11.). Checking the RXSENSE :
Does the test point near HDMI output terminal [N5010] indicate (3.3V)?

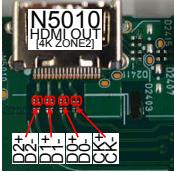

YES NO

Check for a short circuit in the TMDS line.
If there is no problem, the HDMI Switcher1 [U2401] is faulty.
Replace with a new device.

HDMI Switcher1 [U2401] is faulty.
Replace with a new device.

Recheck from check item (3.2.).
If it does not work, replace the PCB.

When the results of check item (3-11.6.) are "32 or 22 or 12 or 02"
(Detection of HPD is not OK / Detection of RXSENSE is OK)

Check the HPD. (HDMI ZONE2 OUT)

Check item(3-11.12.). Checking the HPD :
Does the test point near HDMI output terminal [N5010] indicate Hi(3-5V)?

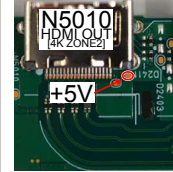

YES NO

Check for a short circuit in the HPD line.
If there is no problem, the HDMI Switcher1 [U2401] is faulty.
Replace with a new device.

HDMI Switcher1 [U2401] is faulty.
Replace with a new device.

Recheck from check item (3.2.).
If it does not work, replace the PCB.

When the results of check item (3-11.6.) are "30 or 20 or 10 or 00"
(Detection of HPD is not OK / Detection of RXSENSE is not OK)

Check the TMDS/HPD. (HDMI ZONE2 OUT)

Check item(3-11.13.). Checking the HPD and RXSENSE. :
Does the test point near HDMI output terminal [N5010] indicate (3.3V)?
Does the test point (HPD) near HDMI output terminal [N5010] indicate "Hi(3-5V)"?

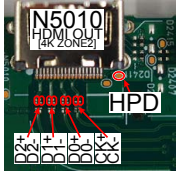

YES NO

Check for a short circuit in the TMDS/HPD line.
If there is no problem, the HDMI Switcher1 [U2401] is faulty.
Replace with a new device.

HDMI Switcher1 [U2401] is faulty.
Replace with a new device.

Recheck from check item (3.2.).
If it does not work, replace the PCB.

3-12. Switcher2 failure detection procedure

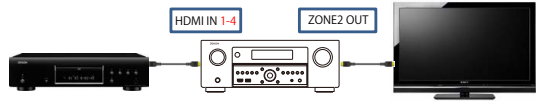

※ In order to check, connect the player to the HDMI terminal and configure the player as AVR source. Next, turn on the power for the player and TV and start playback on the player.

Checking the +5V/DDC status register (HDMI Switcher2)

Check item(3-12.1). Checking the 5V status register :
Send the following command from Termite.exe.

Send the command "i 0056 00FF 0001".

Case of IN1
Is the return value "88 or 80" ?
(IN2 : "44 or 40", IN3 : "22 or 20", IN4 : "11 or 10")

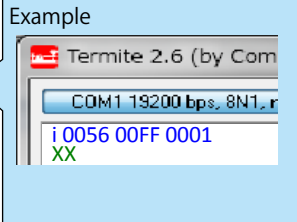

YES

NO

Go to **check item (3-12.3).**

Check item(3-12.2). Checking the DDC status register :
Send the following command from Termite.exe.

Case of IN1
Send the command "i 0053 00B4 0001".
Case of IN2
Send the command "i 0053 0084 0001".
Case of IN3
Send the command "i 0053 0054 0001".
Case of IN4
Send the command "i 0053 0024 0001".

Example

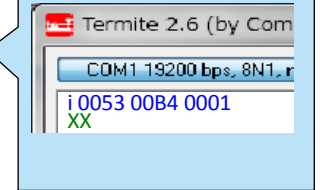

Move to the branch destination according to the value returned.

"00 or 04"
(Detection of DDC is not OK.)

Go to **check item (3-12.4).**

"22 or 11"
(Detection of DDC is OK)

Go to **check item (3-12.5).**

When the results of check item (3-12.1.) are "NO"
(Detection of 5V is not OK)

Check the +5V voltage. (HDMI IN1 - 4)

Check item(3-12.3.). Check the +5V voltage.
Does the test point near HDMI input terminal [N2603/N2700/N2600/N2601] indicate 5V?

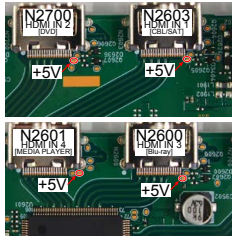

YES

HDMI Switcher2 [U2601] is faulty.
Replace with a new device.

NO

Check for a short circuit in the 5V line and the 5V Switch IC [U2400].
If there is no problem, the HDMI Switcher2 [U2601] or the 5 V Switch IC [U2400] is faulty
Replace with a new device.

Recheck from check item (3.3.).
If it does not work, replace the PCB.

When the results of check item (3-12.2.) are "00 or 04"
(Detection of DDC is not OK)

Check the DDC line. (HDMI IN1 - 4)

Check item(3-12.4.). Check the DDC line :
Are waveforms of "DDCSCK" and "DDCSDA" observed at the test point near the HDMI input terminal [N2603/N2700/N2600/N2601]?

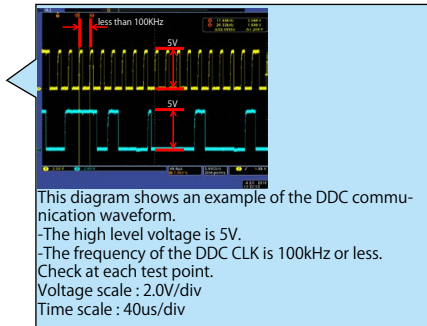
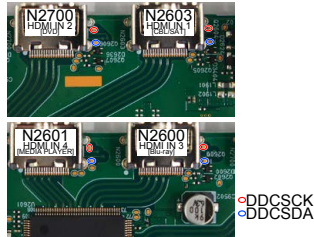

YES

HDMI Switcher2 [U2601] is faulty.
Replace with a new device.

NO

Check for a short circuit in the DDC line.
If there is no problem, the HDMI Switcher2 [U2601] is faulty.
Replace with a new device.

Recheck from check item (3.3.).
If it does not work, replace the PCB.

Before Servicing
This Unit

Electrical

Mechanical

Repair Information

Updating

When the results of check item (3-12.2.) are "22 or 11"
(Detection of DDC is OK.)

Checking the TMDS status register (HDMI Switcher2)

Check item(3-12.5). Checking register of the TMDS CLK detection status register :

Send the following command from Termite.exe.
Send the command "i 0056 00FF 0001".

When the following value is returned, go to YES.
HDMI IN1 "88", HDMI IN2 "44", HDMI IN3 "22", HDMI IN4 "11"

When the following value is returned, go to NO.
HDMI IN1 "80", HDMI IN2 "40", HDMI IN3 "20", HDMI IN4 "10"

Example

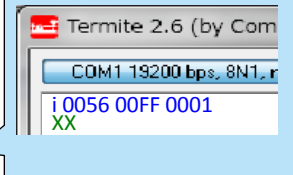

NO

YES

Checking the TMDS status register (HDMI Switcher2 -> HDMI Switcher1)

Check item(3-12.7). Check the TMDS CLK detection status of the register.

Send the following command from Termite.exe.
Send the command "i 002E 00FF 0001".

Is the return value "88" ?

Example :

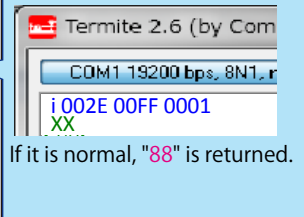

If it is normal, "88" is returned.

NO

YES

HDMI Switcher1 [U2401] is faulty.
Replace with a new device.

Recheck from [check item \(3.3.\)](#).
If it does not work, replace the PCB.

Check item(3-12.6). Checking the TMDS input waveform. :
Check the TMDS waveform at the following test point.
Is the waveform like the sample?



HDMI IN1
42/43/45/46/48/49/51/52 pin
HDMI IN2
55/56/58/59/61/62/64/65 pin
HDMI IN3
80/81/83/84/86/87/89/90 pin
HDMI IN4
93/94/96/97/99/100/ 102/103 pin

YES

NO

HDMI Switcher2 [U2601] is faulty.
Replace with a new device.

Check for a short circuit in the pattern of the TMDS line of the HDMI Switcher2 [U2601] from the HDMI input terminal.
If there is no problem, the HDMI Switcher2 [U2601] is faulty.
Replace with a new device.

Recheck from [check item \(3.3.\)](#).
If it does not work, replace the PCB.

Check item(3-12.8). Checking the TMDS input waveform. :
Check the TMDS waveform at the following test point.
Is the waveform like the sample?



42/43/45/46/48/49/51/52 pin

YES

NO

Check for a short circuit in the TMDS line.
If there is no problem, the HDMI Switcher2 [U2601] is faulty.
Replace with a new device.

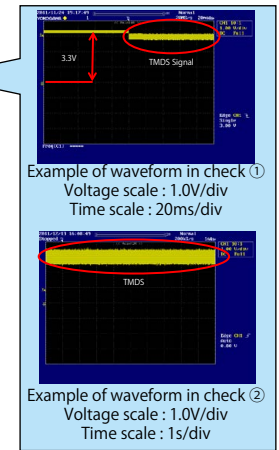

3-13. Tx failure detection procedure

Check the output terminal.

Check item(3-13.1). Check the video output port for failure. :
Check the Monitor 1 output video signal is correct.

After checking the Monitor 1, change the HDMI cable connection from OUT1 to OUT2.
Turn off the AV AMP and turn it on again.
To check under the same conditions, use the same procedure as that for checking Monitor 1 when checking the Monitor 2 output.

No video signal is output from both Monitor 1 and
Monitor 2.

Also, No video signal is output from Monitor 1 only.

Go to [check item \(3-13.2\).](#)

No video signal is output from Monitor 2 only.

Go to [check item \(3-13.9\).](#)

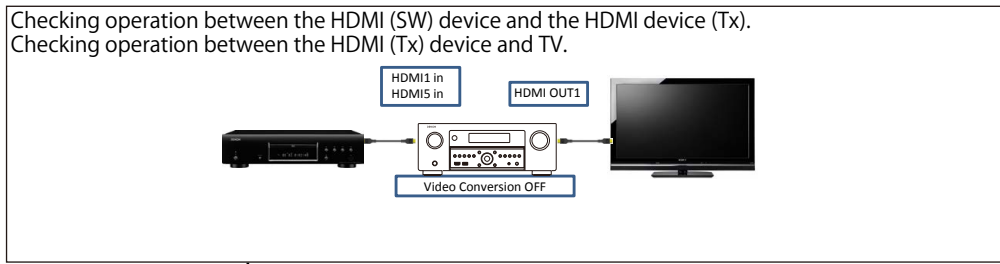

Checking the TMDS status register (Switcher1/2 -> HDMI Tx)

Check item(3-13.2). Check the TMDS CLK detection status of the register.
Send the following command from Termit.exe.

Case of IN1
Send the command "i 0001 00C1 0001".
Case of IN5
Send the command "i 0001 00C0 0001".

When the following value is returned, go to YES.
"Other than 11"
When the following value is returned, go to NO.
"11"

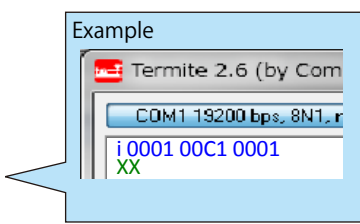

YES

The first operation : Checking between Monitor 1 and the TV.
Go to **check item (3-13.1).**

Check item(3-13.3). Checking the TMDS input. :
TMDS waveform at the following points.

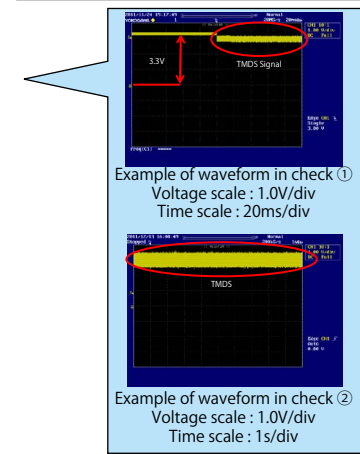
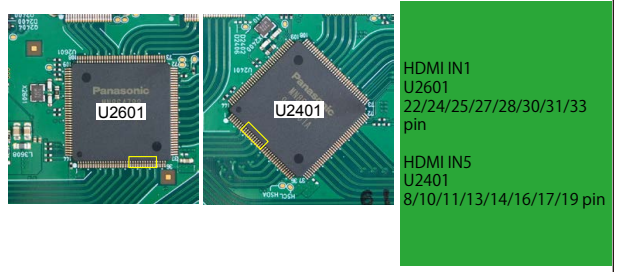

NO

HDMI Tx [U9101] is faulty.
Replace with a new device.

YES

Recheck from **check item (3.4).**
If it does not work, replace the PCB.

NO

Case of HDMI IN1
HDMI Switcher2 [U2601] is faulty.
Replace with a new device.

Case of HDMI IN5
HDMI Switcher1 [U2401] is faulty.
Replace with a new device.

Checking between Monitor1 and the TV.
Connect Monitor1 to the TV and check the following items with the TV turned on.

Checking the HPD status register (HDMI Tx -> Monitor)

Check item(3-13.4). Check the HPD register value of the HDMI TX device. :
Send the following command from Termit.exe.
Send the command "i 0000 00FF 0001".
Move to the branch destination according to the value returned.

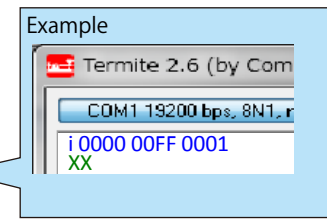

"62"
(Detection of HPD is OK)

Go to **check item (3-13.5).**

"60"
(Detection of HPD is not OK.)

Go to **check item (3-13.8).**

When the results of check item (3-13.4.) are "62"
(Detection of HPD is OK)

Checking the EDID register. (HDMI OUT1)

Check item(3-13.5). Check the Monitor EDID :
 ① Unplug the AC cord. Plug the AC cord into a power outlet.
 ② Send the transmission command "m_1" from Termite.exe.
 Are the first eight bytes of the returned value "00FFFFFFF00"?

Example

The first eight bytes are normally "00FFFFFFF00".
 The correct resistor value cannot be checked if the AVR and TV are not connected by HDMI.

YES **NO**

Example of waveform in check ①
 Voltage scale : 1.0V/div
 Time scale : 20ms/div

Example of waveform in check ②
 Voltage scale : 1.0V/div
 Time scale : 1s/div

This diagram shows an example of the DDC communication waveform.
 -The high level voltage is 5V.
 -The frequency of the DDC CLK is 100kHz or less.
 Check at each test point.
 Voltage scale : 2.0V/div
 Time scale : 40us/div

Check item(3-13.6). Checking the TMDS :
 Check the TMDS waveform at the following test point.

Check item(3-13.7). Check the communication :
 Are the waveforms for "CKL" and "DATA" at the test point near the HDMI output connector [N9013] correct (as shown in the figure)?

YES **NO**

Check for a short circuit in the TMDS line.
 If there is no problem, the HDMI Tx [U9101] is faulty.
 Replace with a new device.

YES **NO**

Check for a short circuit in the DDC line.
 If there is no problem, the HDMI Tx [U9101] is faulty.
 Replace with a new device.

HDMI Tx [U9101] is faulty.
 Replace with a new device.

HDMI Tx [U9101] is faulty.
 Replace with a new device.

Recheck from check item (3.4).
 If it does not work, replace the PCB.

When the results of check item (3-13.4.) are "60"
(Detection of HPD is not OK.)

Check the HPD. (HDMI OUT1)

Check item(3-13.8). Checking the HPD :
Is "Hi(3-5V)" indicated for "19pin"(HPD) in the HDMI output terminal [N9103]?

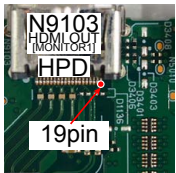

YES

NO

Check for a short circuit in the HPD line.
If there is no problem, the HDMI Tx [U9101] is faulty.
Replace with a new device.

HDMI Tx [U9101] is faulty.
Replace with a new device.

Recheck from check item (3.4).
If it does not work, replace the PCB.

Checking between Monitor 2 and the TV.
Connect Monitor2 to the TV and check the following items with the TV turned on.

Checking the HPD status register (HDMI OUT2)

Check item(3-13.9). Check the HPD register value of the HDMI TX device. :
Send the following command from Termite.exe.
Send the command "i 0000 00FF 0001".
Move to the branch destination according to the value returned.

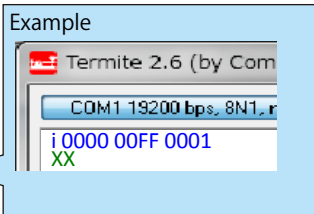

"61"
(Detection of HPD is OK)

Go to **check item (3-13.10).**

"60"
(Detection of HPD is not OK.)

Go to **check item (3-13.13).**

When the results of check item (3-13.9.) are "61"
(Detection of HPD is OK)

Checking the EDID register. (OUT2)

Check item(3-13.10.). Check the Monitor EDID :
① Unplug the AC cord. Plug the AC cord into a power outlet.
② Send the transmission command "m_2" from Termite.exe.
Are the first eight bytes of the returned value "00FFFFFFFFF00"?

Example

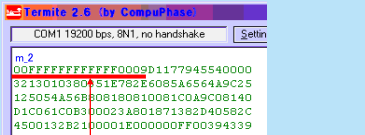

The first eight bytes are normally "00FFFFFFFFF00".
*If the AVR and the TV are not connected via HDMI, the correct register value cannot be verified.

YES

NO

Check item(3-13.11.). Checking the TMDS :
Check the TMDS waveform at the following test point.

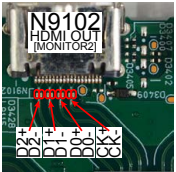

Check item(3-13.12.). Check communication with the monitor :
Are waveforms of "DDCSCK" and "DDCSDA" observed at the test point near the HDMI output terminal [N9012]?

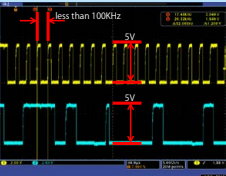
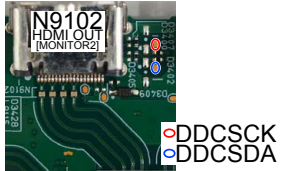

This diagram shows an example of the DDC communication waveform.
-The high level voltage is 5V.
-The frequency of the DDC CLK is 100kHz or less.
Check at each test point.
Voltage scale : 2.0V/div
Time scale : 40us/div

YES NO

YES NO

Check for a short circuit in the TMDS line.
If there is no problem, the HDMI Tx [U9101] is faulty.
Replace with a new device.

HDMI Tx [U9101] is faulty.
Replace with a new device.

HDMI Tx [U9101] is faulty.
Replace with a new device.

HDMI Tx [U9101] is faulty.
Replace with a new device.

Recheck from check item (3.4).
If it does not work, replace the PCB.

When the results of check item (3-13.9.) are "60"
(Detection of HPD is not OK.)

Check the HPD. (OUT2)

Check item(3-13.13.). Checking the HPD :
Does the voltage of HPD test point close to the HDMI output terminal
[N9012] indicate Hi (3-5V)?

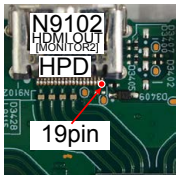

YES NO

Check for a short circuit in the HPD line.
If there is no problem, the HDMI Tx [U9101] is faulty.
Replace with a new device.

HDMI Tx [U9101] is faulty.
Replace with a new device.

Recheck from check item (3.4).
If it does not work, replace the PCB.

3-14. HDMI IN7 failure detection procedure

Checking operation between the HDMI IN7 and the player



※ In order to check, connect the player to the HDMI terminal and configure the player as AVR source. Check the sound output while turning on the player.

Checking the +5V/DDC status register

Check item(3-14.1). Checking the 5V status register :
Send the following command from Termit.exe.
Send the command "i 0000 00FF 0001".

Check the value.
Move to the branch destination according to the value returned.

Example

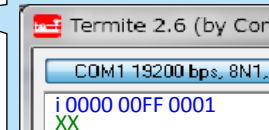

"61"
(Detection of 5V is not OK.)

Go to [check item \(3-14.4\)](#)

"71"
(Detection of 5V is OK)

Check item(3-14.2). Checking the status register :
Send the following command from Termit.exe.
Send the command "i 0003 0026 0001".

Check the value.
Move to the branch destination according to the value returned.

Example

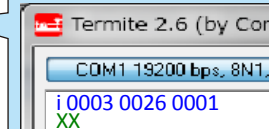

"0E"
(Detection of DDC is OK)

Go to [check item \(3-14.6\)](#)

"Other than 0E"
(Detection of DDC is not OK.)

Check item(3-14.3). Checking the status register :
Send the following command from Termit.exe.
Send the command "i 0005 0009 0001".

Check the value.
Move to the branch destination according to the value returned.

Example

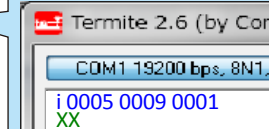

"Other than 03"
(Detection of DDC is not OK.)

Go to [check item \(3-14.5\)](#)

"03"
(Detection of DDC is OK)

Go to [check item \(3-14.6\)](#)

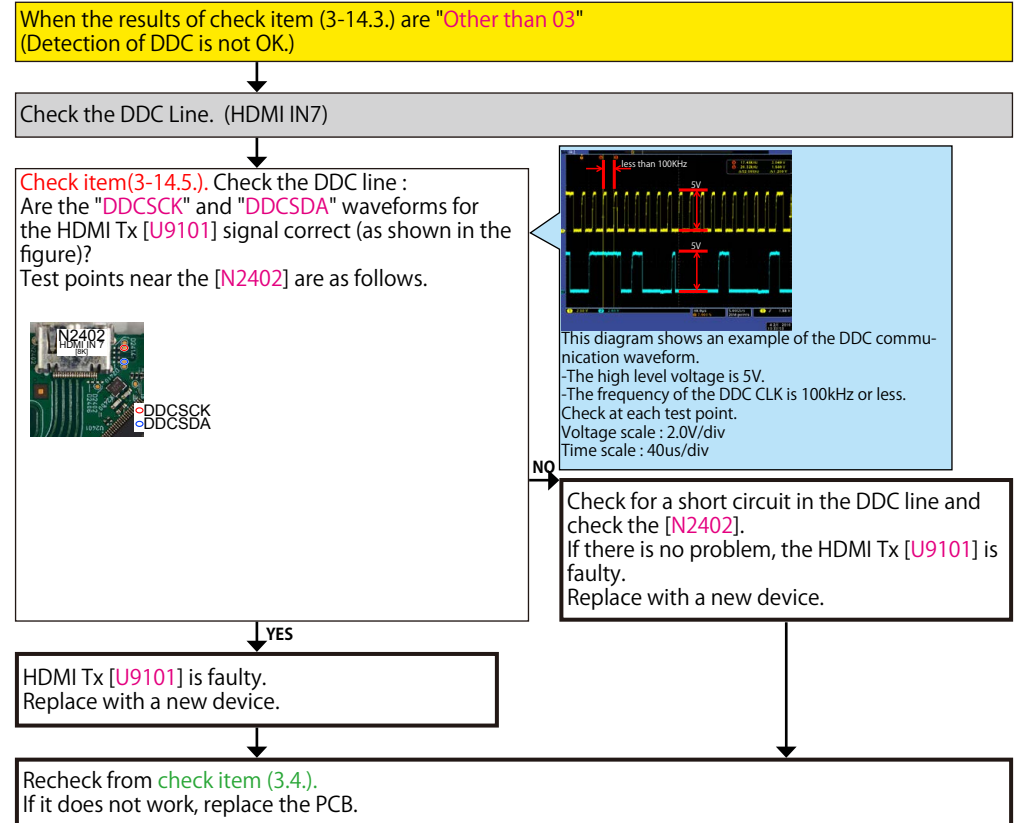
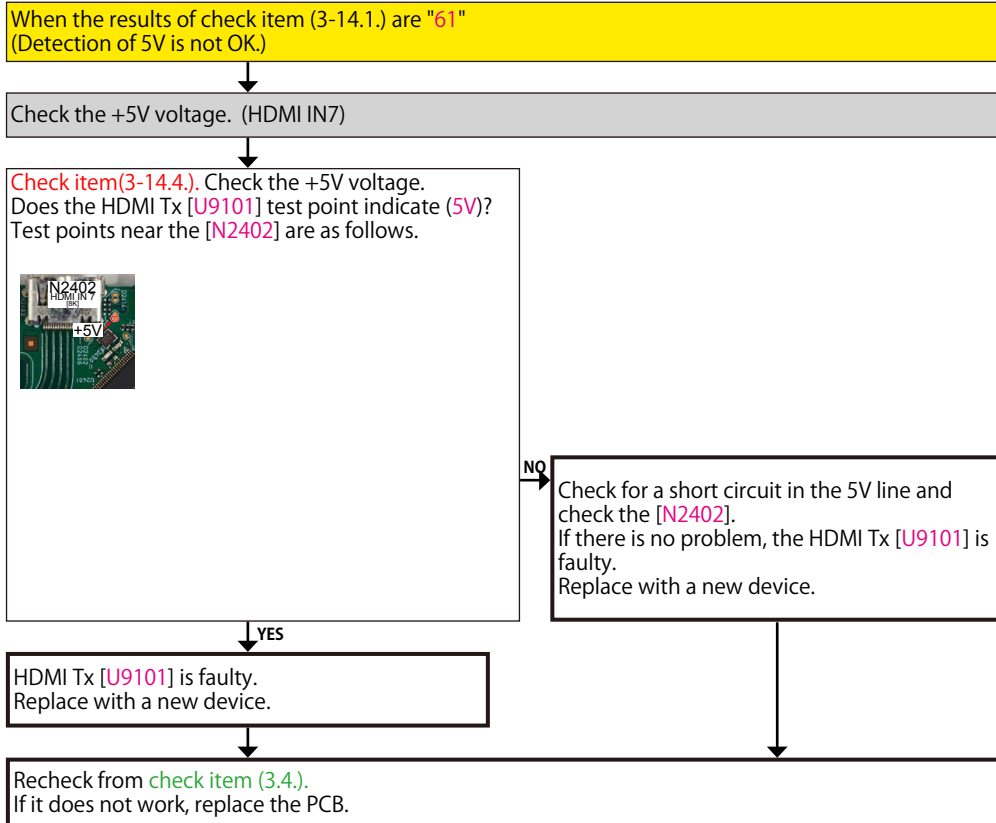

When the results of check item (3-14.2.) are "22"
 When the results of check item (3-14.3.) are "03"
 (Detection of DDC is OK)

Checking the TMDS status register (HDMI IN7)

Check item(3-14.6). Check the TMDS CLK detection status of the register.
 Send the following command from Termite.exe.
 Send the command "i 0001 00C0 0001".
 When the following value is returned, go to YES.
 "Other than 11"
 When the following value is returned, go to NO.
 "11"

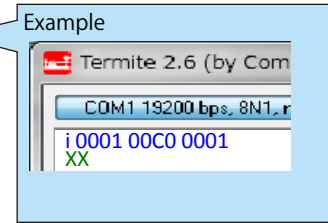

YES

NO

Check item(3-14.8). Check the AUDIO signal output :
 Check the AUDIO signal waveform at the following test point.
 (MCK/64FS/FS/I2S0/I2S1/I2S2/I2S3)

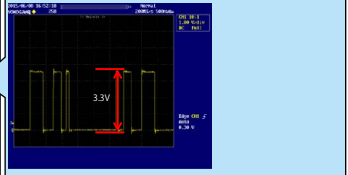

The diagram shows an example of the waveform of I2S0.
 Waveform check points
 - Crest value (3.3 V normally)
 - Signal change
 Check the waveform of each pin.
 Voltage scale : 1.0V/div
 Time scale : 500us/div

YES

NO

The DIGITAL AUDIO block is faulty.
 Check the DIGITAL AUDIO device.
 Check "AUDIO" in troubleshooting.
 If it does not work, replace the PCB.

HDMI TX [U9101 or U9105] is faulty.
 Replace with a new device.

Recheck from **check item (3.4.)**.
 If it does not work, replace the PCB.

Check item(3-14.7). Checking the TMDS input waveform :
 Check the TMDS waveform at the following test point.
 Is the waveform like the sample?

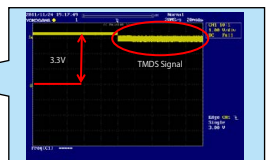
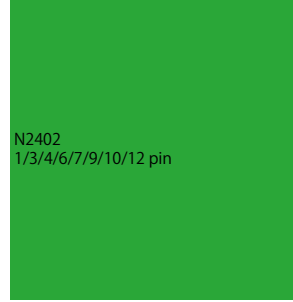

Example of waveform in check ①
 Voltage scale : 1.0V/div
 Time scale : 20ms/div

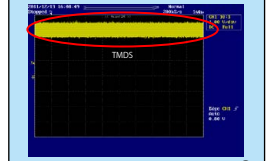

Example of waveform in check ②
 Voltage scale : 1.0V/div
 Time scale : 1s/div

YES

NO

HDMI Tx [U9101] is faulty.
 Replace with a new device.

Check for a short circuit in the TMDS line and check the [N2402].
 If there is no problem, the HDMI Tx [U9101] is faulty.
 Replace with a new device.

Recheck from **check item (3.4.)**.
 If it does not work, replace the PCB.

3-15. GUI and PLD failure detection procedure

Check item(3-15.1.). Does a video signal come from HDMI OUT to TV correctly? :

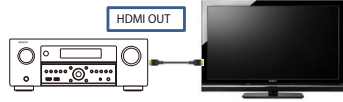

Turn Video Conversion "ON" on the setup menu.
 (SETUP MENU-> Video-> Output Settings-> Video Conversion = On)
 When the "SETUP" button on a remote control is pressed, is "MENU" displayed on TV which is connected to the HDMI output terminal on the AVR?

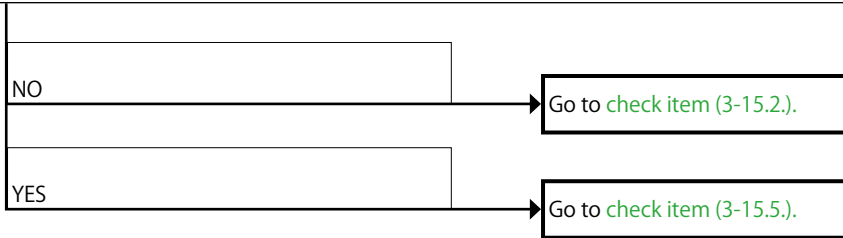

When the results of check item (3-15.1.) are "NO"
 (When the menu display is not OK)

Check the Video signal line. (GUI -> HDMI Tx)

Check item(3-15.2.). Check the format of the resistor video signal :
 Send the following command from Termite.exe.
 Send the command "i 00ED 0044 0001".
 When the following value is returned, go to YES.
 "Other than 00"
 When the following value is returned, go to NO.
 "00"

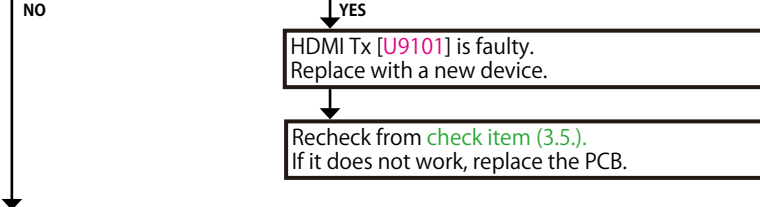
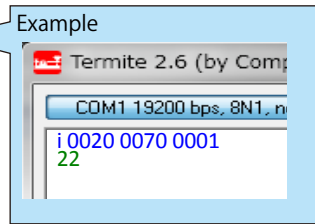

Check the Video signal line. (GUI -> PLD)

Check item(3-15.3.). Check the PLD video signal line from the GUI :
 Check the video signal waveform at the following test point.
 Is the waveform like the sample?

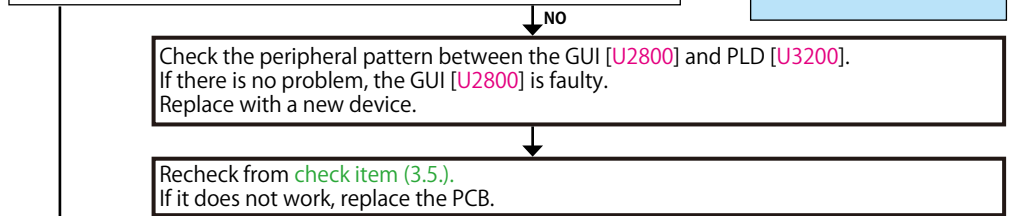
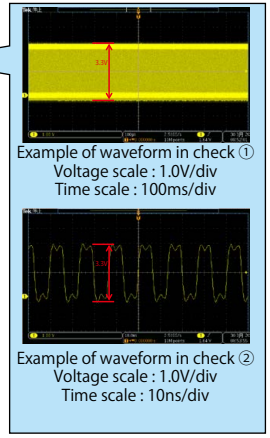

Check the Video signal line. (PLD -> HDMI Tx)

Check item(3-15.4.). Check the HDMI Tx video signal line from the PLD :
 Check the video signal waveform at the following test point.
 Is the waveform like the sample?

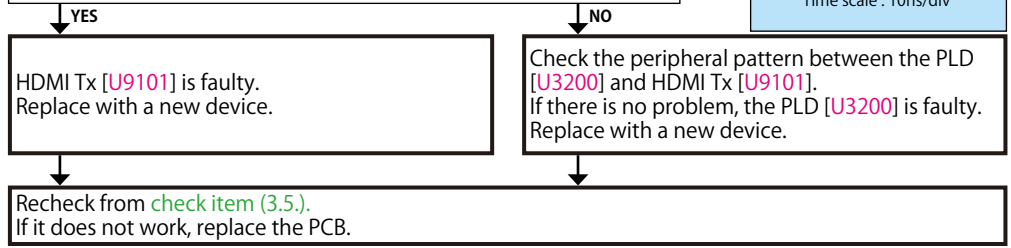
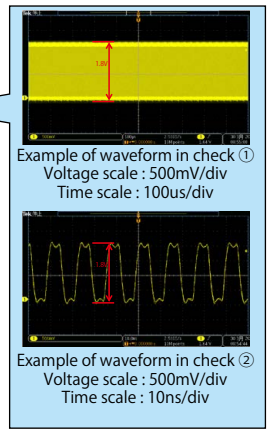
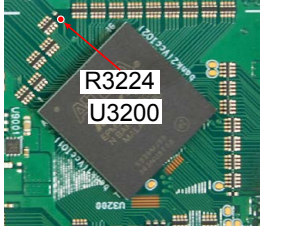

When the results of check item (3-15.1.) are "YES"
(When the menu display is OK)

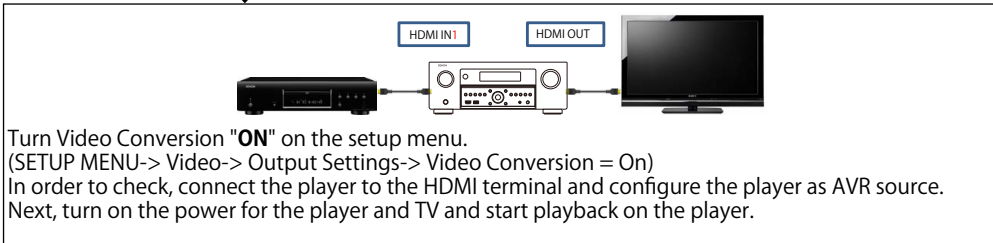

Check the Video signal line. (HDMI Tx -> PLD)

Check item(3-15.5). Check the PLD video signal line from the HDMI Tx:
Check the video signal waveform at the following test point.
Is the waveform like the sample?

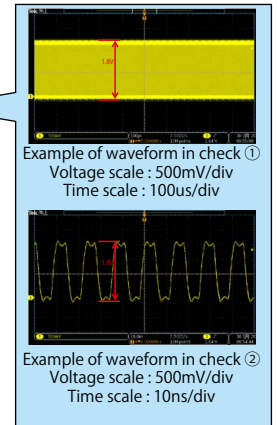
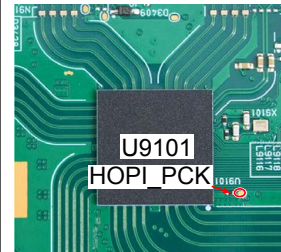

YES

NO

Check the peripheral pattern between the HDMI Tx [U9101] and PLD [U3200].
If there is no problem, the HDMI Tx [U9101] is faulty.
Replace with a new device.

Recheck from **check item (3.5.)**.
If it does not work, replace the PCB.

Check the Video signal line. (PLD -> GUI)

Check item(3-15.6). Check the GUI video signal line from the PLD :
Check the video signal waveform at the following test point.
Is the waveform like the sample?

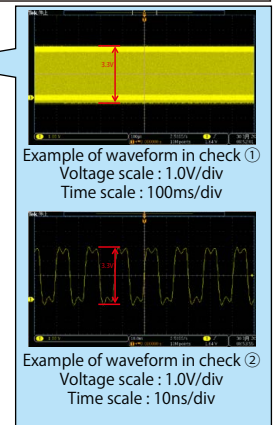

YES

NO

GUI [U2800] is faulty.
Replace with a new device.

Check the peripheral pattern between the PLD [U3200] and GUI [U2800].
If there is no problem, the PLD [U3200] is faulty.
Replace with a new device.

Recheck from **check item (3.5.)**.
If it does not work, replace the PCB.

4. Device implementation location

DIGITAL (A SIDE)

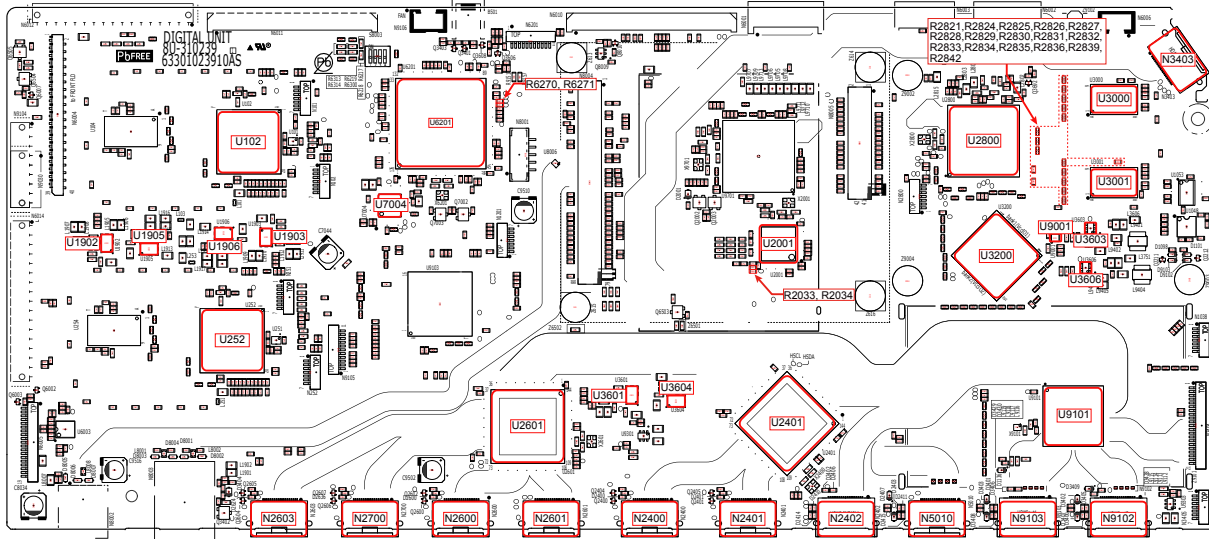

F-HDMI (A SIDE)

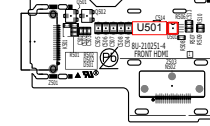

DIGITAL (B SIDE)

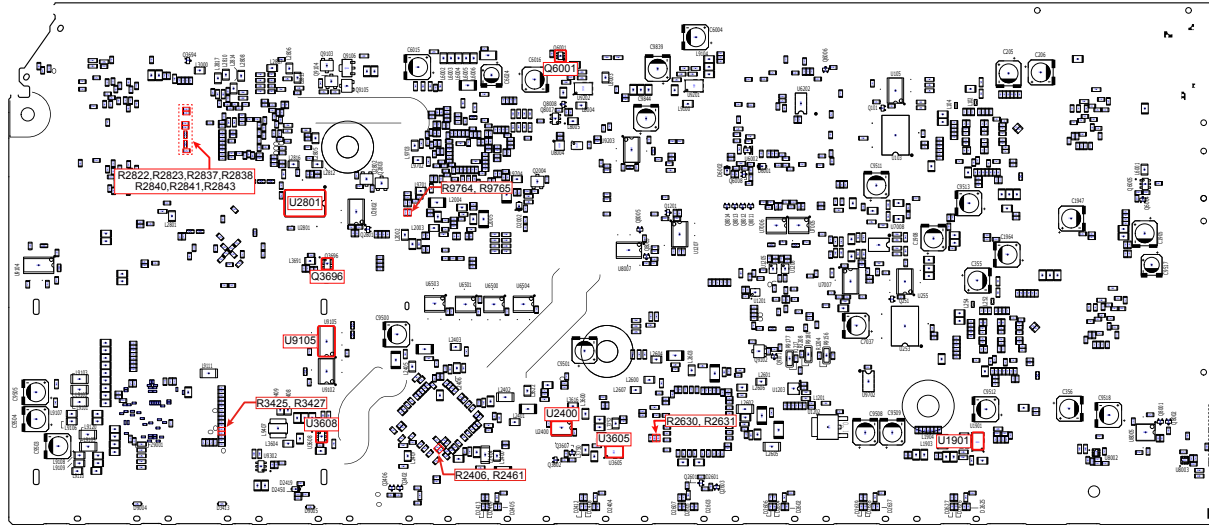

Before Servicing
This Unit

Electrical

Mechanical

Repair Information

Updating

SPECIAL MODE

Special mode setting button

※ No. 1 - 4, 6 - 8: While holding down buttons "A", "B" and "C" simultaneously, press the power button to turn on the power.

※ No. 5, 9, 10: While the power is on, hold down buttons "A", "B", and "C" for at least 3 seconds.

No.	Mode	Button A	Button B	Button C	Descriptions
1	Version Display Mode (MCU / DSP Error Display)	SETUP	OPTION	-	Displays the version of firmware such as the MCU or DSP. Errors that have occurred are displayed. (See 1. Version Display Mode)
2	PANEL / REMOTE LOCK Selection Mode	STATUS	INFO	-	Activates the unit in PANEL/REMOTE LOCK selection mode to enable PANEL LOCK and Remote Lock On/Off to be set. (See 2. PANEL / REMOTE LOCK Selection Mode)
3	Selecting the Mode for Service-related	ZONE3 SOURCE	STATUS	-	A selection mode for entering service-related modes. Service-related modes : No. 3-1 - No. 3-6 (See 3-1. Selecting the Mode for Service-related)
3-1	Check the Video/Audio path Mode	↑	↑	-	This is a special mode for service confirmation used during repair work to simplify the confirmation work for the Audio channel / video channel. (See Service Path Check Mode)
3-2	Protection history display mode	↑	↑	-	Displays the latest occurred protection history. (See 3-2. Protection History Display Mode)
3-3	232C Standby Clear Mode	↑	↑	-	Switches from 232C standby mode to normal standby mode. (See 3-3. 232C Standby Clear Mode)
3-4	Operation Info Mode	↑	↑	-	Displays the accumulated operating time of the unit, the number of times the power was switched on, and the number of occurrences of each protection. (See 3-4. Operation Info Mode)
3-5	TUNER STEP Mode (E3 model only)	↑	↑	-	Enables the FM/AM tuner reception frequency step to be changed. (See 3-5. TUNER STEP mode (E3 only))
3-6	Remote ID Setup Mode	↑	↑	-	If there are multiple DENON AV receivers in the same area, this mode prevents other AV receivers from being operated concurrently with this device. (See 3-6. Remote ID Setup Mode)
4	Protection Pass Mode	ZONE3 SOURCE	STATUS	CURSOR ◀	Enables the power to be turned on when protection detection is disabled. (See 4. Protection Pass Mode)
5	Network Initialization Mode	CURSOR ▶	DIMMER	-	Network module backup data is initialized. (See 5. Network Initialization Mode)
6	User Initialization Mode	BACK	INFO	-	Initialize the backup data for the MCU and network module. (Settings for the Installer Setup are not initialized.)
7	Factory Initialization Mode	INFO	SETUP	-	Initialize the backup data only for MCU. (Settings for the Installer Setup are initialized) (Network function settings are not initialized.) (See POST-SERVICE PRECAUTIONS)
8	Clearing of Operation Info	OPTION	DIMMER	-	Clear the accumulated operating time of the unit, the number of times the power was switched on, and the number of occurrences of each protection. (See 6. Clearing of Operation Info)
9	HDMI Diagnostics Mode	CURSOR ▲	BACK	-	This mode is used to identify and solve the cause when there is a connectivity issue with this unit and an HDMI device. For details on the operating methods and diagnosis procedures, see the HDMI Diagnostics and Troubleshooting guide issued on SDI.
10	Log Capture feature	BACK	OPTION	-	Acquires the Network Module log. As the Network Module reboots, the log is deleted. Make sure to obtain the log before turning off the unit's power. (See 7. Log Capture feature)

NOTE: When the volume indicator displays "-00.8", the unit has entered a special mode for developers. In this case, the RS-232C communication is not available.

To release this special mode, press and hold the "STATUS" and "CURSOR ▼" buttons for 3 seconds or more while the power is ON. When the volume indicator returns to the normal display, the RS-232C communication is available.

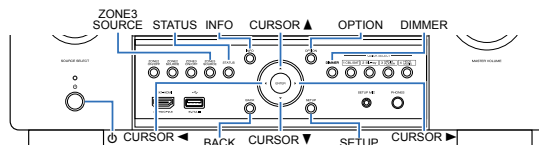

1. Version Display Mode

1.1. Actions

Version information is displayed when the device is started in this mode.

1.2. Starting up

While holding down buttons "SETUP" and "OPTION" simultaneously, press the power button to turn on the power.

then press the "STATUS" button to display the information in section 1.3 on the display.

※ The version list is also displayed on GUI while the version is displayed on the display.

1.3. Display Order

Error information(See "1.4. Error display") → ① Model destination information, Serial Number → ② Firmware Package → ③ MCU, MCU 1st Boot Loader → ④ DSP1/2 ROM → ⑤ Audio Video PLD → ⑥ GUI SFLASH → ⑦ HEOS Version → ⑧ HEOS Build → ⑨ HEOS Module → ⑩ HEOS Configuration → ⑪ HEOS Locale → ⑫ Restore Version → ⑬ Ether Mac Address → ⑭ WiFi Mac Address → ⑮ BT Mac Address → ⑯ Audyssey App Interface Version

① Model destination information, Serial Number :

L1	000-X6700H \\\
L2	SN: *****

0 : Model name (AVR, AVC)
 \ : Region (E3, E2, E1C, JP)

② Firmware Package :

L1	Firm. Package
L2	Ver. : ****

③ MCU, MCU 1st Boot Loader :

L1	M: *****
L2	Main FBL : **. **

④ DSP 1/2 ROM :

L1	DSP1 : **. **
L2	DSP2 : **. **

⑤ Audio, Video PLD :

L1	A. PLD : *****
L2	V. PLD : *****

⑥ GUI SFLASH :

L1	GUI : 00\$~****
----	-----------------

0 : Model code
 # : Brand code (Non=0, De=1, Mz=2, Mc=3)
 \ : Region code (E3=1, E2=2, E1C=5, JP=4, ALL=0)
 * : version

⑦ HEOS Version :

L1	HEOS Version
L2	*, **, ***

⑧ HEOS Build :

L1	HEOS Build
L2	*****

⑨ HEOS Module :

L1	HEOS Module
L2	***

⑩ HEOS Configuration :

L1	HEOS Config
L2	Development
	Production

⑪ HEOS Locale :

L1	HEOS Locale
L2	*****

⑫ Restore Version :

L1	RSTR
L2	*****

⑬ Ether Mac Address :

L1	*Ether MAC
L2	*****-*****

⑭ WiFi Mac Address :

L1	*Wi-Fi MAC
L2	*****-*****

⑮ BT Mac Address :

L1	*BT MAC Address
L2	*****-*****

⑯ Audyssey App Interface Version :











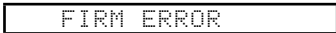

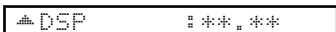

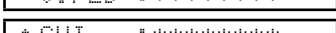
L1	Audy IFVer: **. **
L2	

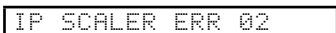
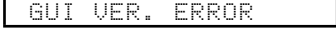
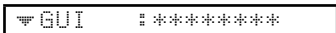
1.4. Error display

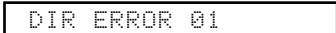
See the table below for descriptions of the displayed errors and countermeasures for these.

If multiple errors occur, only one item is displayed.

The priority order is ②, ③, ④, ⑤, ⑥, ①.

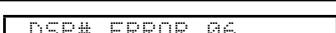
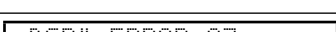
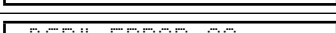
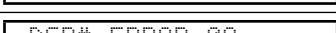
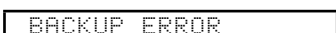
Condition	States	Display	TROUBLE SHOOTING
① Firm Check Error	<p>The model name, brand name and region information written in the firmware are compared to the region settings in the PCB. This error is displayed if the information does not match.</p> <p>"▲" is not displayed if firmware information is correct.</p>	      	<ul style="list-style-type: none"> •Check the resistor for setting the region [R6217, R6218, R6219, DIGITAL PCB]. •Write the firmware for the correct region.
② IP SCALER Error	<p>An error occurs in Loop back Test of the DDR memory which is performed during the initial setting of i/p Scaler(ADV8003).</p> <p>During the initial setting of i/p Scaler (ADV8003) , there is not the reply of the Loop back Test result of the DDR memory .</p>	 	<ul style="list-style-type: none"> •Check the circuits around the IP SCALER [U2800, DIGITAL PCB] and DDR2 [U3000/U3001]. If there appear to be no problems, [U2800] or [U3000/U3001] is faulty.
③ GUI Serial Flash Error	<p>If the MCU version is not supported by the GUI Serial Flash (ADV8003), "▼" is displayed as the first character of the GUI firmware version.</p> <p>If GUI Serial Flash is damaged, "▲" is displayed as the first character.</p>	  	<ul style="list-style-type: none"> •Check the firmware version.
④ DIR Error	<p>This error is displayed if there is no response from the DIR.</p>		<ul style="list-style-type: none"> •Check the DIR [U7004, DIGITAL PCB] and surrounding circuits.
⑤ DSP# NG (# : 1/2)	<p>Boot error 1 (After reset the DSP, DSP_Flag0 port is "Low")</p> <p>Boot error 2 (After reset the DSP, DSP initialization is not completed)</p> <p>(Unused)</p> <p>Command error 1 (After sending the command to the DSP, DSP_Flag0 port is "Low".)</p> <p>Command error 2 (After sending the command to the DSP, MCU received "COMMAND ERROR".)</p> <p>Command error 3 (After sending the command to the DSP, MCU did not receive "COMMAND SUCCESS".)</p> <p>IDL error 1 (Before receiving IDL, "COMMAND BYTE" is not cleared.)</p> <p>IDL error 2 (MCU received "IDL SERIOUS ERROR".)</p> <p>SPI communication error</p>	        	<ul style="list-style-type: none"> •Check the DSP [U102, U252, DIGITAL PCB] and surrounding circuits.
⑥ BACKUP Error	<p>Error occurred in BACKUP. it is an error of the check sum.</p>		

1.5. Version Display in the Setup Menu

Follow the steps below to display the firmware information.

- (1) Press the "SETUP" button on the remote control.
- (2) Select "General - Information - Firmware".

The version information is displayed as a 16-digit number as shown in the screenshot below.

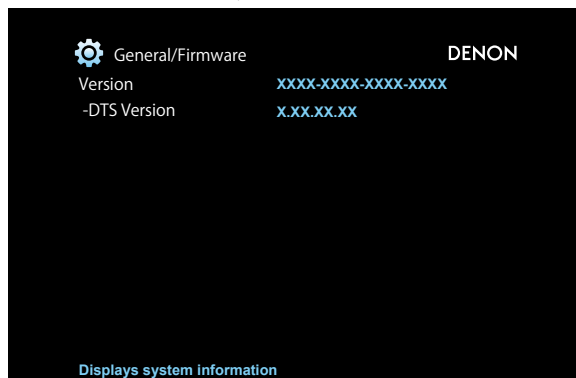

GUI Image

This 16-digit number comprises a part of the version number of each device and module. Numerics and version numbers correspond as shown below.

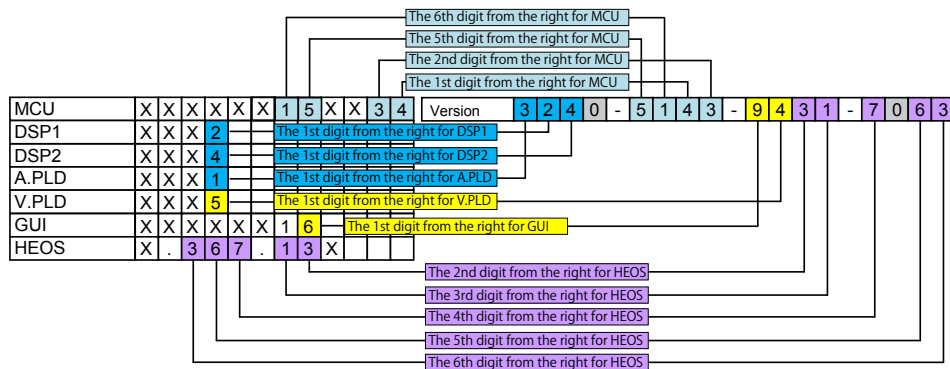

※ The firmware version numbers and this 16-digit version information are written in the Service Information.

※ Replace as follows for the 5th to 7th digits of HEOS version.

- X.XXX.X → X.XXX.00X
- X.XXX.XX → X.XXX.0XX
- X.XXX.XXX → X.XXX.XXX

2. PANEL / REMOTE LOCK Selection Mode

2.1. Actions

Switch the PANEL LOCK and REMOTE LOCK modes between on and off.

- PANEL LOCK Mode (with Volume)
Disables reception from all keys and encoders on the front panel except the power button (including the volume).
- PANEL LOCK Mode (without Volume)
Disables reception from all keys and encoders on the front panel except the power button and volume encoder.
- PANEL LOCK mode is turned off

2.2. Starting up

While holding down buttons "STATUS" and "INFO" simultaneously, press the power button to turn on the power.

Select the desired mode using the "CURSOR ▼/▲" button, then press the "ENTER" button to confirm.

2.3. Displaying and Selecting Each Mode

The information shown on the display switches each time the "CURSOR ▼/▲" button is pressed.

Press the "ENTER" button to set the currently displayed mode and restart the device.

The setting with "*" is selected for each mode.

①

L1	▶FP/VOL LOCK On
L2	▶FP LOCK On

The buttons on the unit and the master volume knob does not function.



②

L1	FP/VOL LOCK On
L2	▶▶FP LOCK On

The buttons on the unit does not function.



③

L1	FP LOCK On
L2	▶▶FP LOCK *Off

The PANEL LOCK mode is turned off.



④

L1	FP LOCK Off
L2	▶▶RC LOCK On

The device cannot be operated by the remote control.



⑤

L1	RC LOCK On
L2	▶▶RC LOCK *Off

The REMOTE LOCK mode is turned off.

3-1. Selecting the Mode for Service-related

3-1.1. Actions

Select diagnostic mode (service path check mode), protection history display mode, 232C standby clear mode, Operation Info mode, TUNER STEP mode or Remote ID Setup Mode.

3-1.2. Starting up

While holding down buttons "ZONE3 SOURCE" and "STATUS" simultaneously, press the power button to turn on the power.

Select the desired mode using the "CURSOR ▼/▲" button, then press the "ENTER" button to confirm.

3-1.3. Displaying and Selecting Each Mode

The information shown on the display switches each time the "CURSOR ▼/▲" button is pressed.

Press the "ENTER" button to set the currently displayed mode and restart the device.

①

L1	▶1.SERVICE CHECK
L2	2.PROTECTION

Service Path Check Mode : See "DIAGNOSTIC MODE"

The Video and Audio paths can be checked.

This function is convenient for confirming problem paths in the product and checking the paths after repairing.



②

L1	1.SERVICE CHECK
L2	▶2.PROTECTION

The protection history can be checked.



③

L1	2.PROTECTION
L2	▶3.RS232C RESET

Switches from 232C standby mode to normal standby mode.



④

L1	3.RS232C RESET
L2	▶4.OP INFO

Operation Info for the unit can be checked.



⑤

L1	4.OP INFO
L2	▶5.TUNER FRQ SET

Enables the reception frequency STEP of the ANALOG TUNER to be changed.



⑥

L1	5.TUNER FRQ SET
L2	▶6.REMOTE ID

This function is for operating only the desired AV receiver.

3-1.4. Canceling the selected mode

Press the power button to turn off the power.

3-2. Protection History Display Mode

3-2.1. Actions

This mode enables the unit to record and display the event when the THERMAL, ASO or DC protection is activated.

If protections have been activated multiple times, the latest protection operation is recorded.

3-2.2. Starting up

While holding down buttons "ZONE3 SOURCE" and "STATUS" simultaneously, press the power button to turn on the power.

Select the "2. PROTECT" using the "CURSOR ▼/▲" button, then press the "ENTER" button to confirm.

3-2.3. Protection information and displays

- Press the "STATUS" button in Protection History Display Mode.
- The protection history can be checked.

(1) If no protections has occurred.

L1	PROTECT HISTORY
L2	:NO PROTECT

(2) ASO (if the last protection is ASO)

L2	:ASO
----	------

Cause A short circuit occurred between the speaker terminals, or speakers with an impedance outside the rating were connected.

Note : Short circuits in speaker terminals or speakers can be identified.

If the power is turned on in the abnormal state, protection is activated after around 6 seconds and the power is turned off.

(3) DC (if the last protection is DC)

L2	:DC
----	-----

Cause : DC output of the power amplifier is abnormal.

If the power is turned on in the abnormal state, protection is activated after around 6 seconds and the power is turned off.

(4) Case of THERMAL (when the last protection incident is THERMAL(H) protection)

L2	:THERMAL H
----	------------

Cause : Abnormal heat sink temperature.

If the power is turned on in the abnormal state, protection is activated after around 6 seconds and the power is turned off.

(5) Case of CURRENT (when the last protection incident is CURRENT protection)

L2	:CURRENT
----	----------

Cause : An over current flowed in power amp.

If the power is turned on in the abnormal state, protection is activated after around 90 seconds and the power is turned off.

Caution : These protections may also be activated due to other factors such as disconnection of connectors or operations around the MCU.

After viewing the above protection history, press the "STATUS" button to return to the normal display.

3-2.4. Clearing the Protection History

There are two ways to clear the protection history.

- (1) Activate Protection History Display Mode. Press the **"STATUS"** button to display the protection history.

L1	PROTECT HISTORY
L2	#DC

Press and hold the **"ENTER"** button for 3 seconds.



L2	CLEAR
----	-------

The above is displayed and protection history is cleared.



L2	#NO PROTECT
----	-------------

- (2) Initialize this unit. (See ["POST-SERVICE PRECAUTIONS"](#))

※ Use the method in **3-2.4. (1)** if you do not want to erase your settings from this unit.

Warning Displays by POWER LED

If the power is turned Off while a protection is being detected, the POWER LED flashes in red to warn you depending on the protection status as follows.

- (1) ASO/DC protection: Flashes at 0.5-second intervals (0.25 seconds lit, 0.25 seconds unlit)
- (2) THERMAL(H) protection: Flashes at 2-second intervals (1 seconds lit, 1 seconds unlit)
- (3) CURRENT protection: Flashes at 4-second intervals (2 seconds lit, 2 seconds unlit)

3-3. 232C Standby Clear Mode

3-3.1. Actions

Switches from 232C standby mode to normal standby mode.

3-3.2. Starting up

While holding down buttons **"ZONE3 SOURCE"** and **"STATUS"** simultaneously, press the power button to turn on the power.

Select the **"3. RS232C RESET"** using the **"CURSOR ▼/▲"** button, then press the **"ENTER"** button to confirm.

L1	2. PROTECTION
L2	▶3. RS232C RESET

3-4. Operation Info Mode

3-4.1. Actions

This mode enables the unit to display the accumulated operating time, power On count and each protection count.

3-4.2. Starting up

While holding down buttons "ZONE3 SOURCE" and "STATUS" simultaneously, press the power button to turn on the power.

Select the "4. OP INFO" using the "CURSOR ▼/▲" button, then press the "ENTER" button to confirm.

3-4.3. Operations

Press the "STATUS" button after starting up this device in Operation Info mode.

The following information is displayed in the following order.

- (1) Accumulated operating time

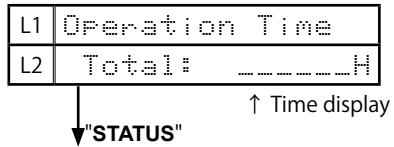

- (2) Power On time

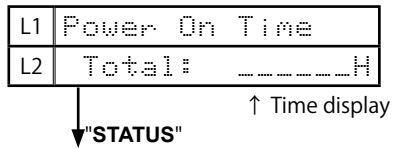

- (3) DC / ASO Protection count



- (4) Thermal Protection (H) count

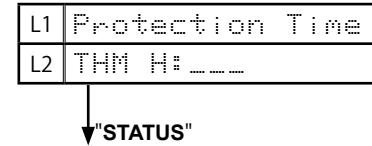

- (5) Current Protection count



(Returns to normal display)

3-5. TUNER STEP mode (E3 only)

3-5.1. Actions

This is a special mode that enables the reception frequency STEP of the ANALOG TUNER to be changed.

3-5.2. Starting up

While holding down buttons "ZONE3 SOURCE" and "STATUS" simultaneously, press the power button to turn on the power.

Select the "5. TUNER FREQ" using the "CURSOR ▼/▲" button, then press the "ENTER" button to confirm.

3-5.3. Displays

Start up this unit in TUNER STEP mode, select the desired option using the "CURSOR ◀/▶" button, then enter using the "ENTER" button.

The following information is displayed in the following order.

- (1) AM9 kHz / FM50 kHz is selected

L1	*TUNER FRO Set
L2	< AM9/FM50 >

"CURSOR ◀" ↓ ↑ "CURSOR ▶"

- (2) AM10 kHz / FM200 kHz is selected

L2	< AM10/FM200 >
----	----------------

↓ "ENTER"

- (3) Press the power button to turn off the power.
(4) Press the power button to turn on the power.

3-6. Remote ID Setup Mode

3-6.1. Actions

This function allows only the desired AV receiver to be operated if multiple DENON AV receivers are used in the same room.

3-6.2. Starting up

While holding down buttons "ZONE3 SOURCE" and "STATUS" simultaneously, press the power button to turn on the power.

Select the "6. REMOTE ID" using the "CURSOR ▼/▲" button, then press the "ENTER" button to confirm.

3-6.3. Operations

- (1) When Remote ID Setup mode is activated, the following message is displayed.

L1	
L2	REMOTE ID ?

- (2) Press the desired "QUICK SELECT 1 - 4" button.

Button	Display
QUICK SELECT 1	L2 REMOTE ID 1
QUICK SELECT 2	L2 REMOTE ID 2
QUICK SELECT 3	L2 REMOTE ID 3
QUICK SELECT 4	L2 REMOTE ID 4

- (3) Press the power button to turn off the power.
(4) Press the power button to turn on the power.

※ Only "QUICK SELECT 1 - 4" and the POWER button on the unit can be used in Remote ID Setup Mode.

3-6.4. Setting the Remote control unit

- (1) Press and hold the "DEVICE MENU" button for at least 3 seconds until the "DEV.", "TU" and "AVR" indicators flash.
(2) Press "MAIN" button.
The "DEV.", "TU" and "AVR" indicators flash twice.
(3) Press the "1", "2", "3" or "4" button.
The "DEV.", "TU" and "AVR" indicators flash twice.

NOTE :

If the ID of the unit and remote control do not match, "AVAMP*" appears on the display of the unit when the remote control is used (* : own remote control ID).

4. Protection Pass Mode

4.1. Actions

- This mode allows the power to be turned on without activating protections.
- This mode functions in the same way as normal power-on, except that protections are not activated.
- When using the protection pass mode, do not connect speakers to the speaker terminals.

4.2. Operations

While holding down buttons "**ZONE3 SOURCE**", "**STATUS**" and "**CURSOR ◀**" simultaneously, press the power button to turn on the power.

The device returns to the normal display message after the following is displayed.

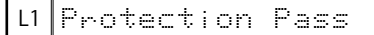

L1 Protection Pass

This is displayed for 5 seconds before returning to the normal display.

5. Network Initialization Mode

5.1. Actions

The following items are initialized.

- (1) Network setup
- (2) Friendly Name
- (3) Auto Update setting
- (4) Allow Update setting
- (5) Time Zone setting
- (6) Queue list
- (7) Internet Radio recently played station
- (8) Quick Select playback station
- (9) AirPlay Password
- (10) Bluetooth Pairing History
- (11) Crestron Connected Setup

5.2. Operations

When the power is on and the input source is HEOS Music, press and hold the "**CURSOR ▶**" and "**DIMMER**" buttons for more than 3 seconds.

Initializing Display



L1 Network Reset...

Complete Display



L1 Completed

This is displayed for 5 seconds before returning to the normal display.

6. Clearing of Operation Info

6.1. Actions

- Displays the accumulated operating time of the unit, the number of times the power was switched on, and the number of occurrences of each protection.

6.2. Operations

Remove all input/output terminals and the AC plug.

Connect the AC plug again and place the product in standby mode.

While holding down buttons "OPTION" and "DIMMER" simultaneously, press the power button to turn on the power.

L1	PRODUCT MODE P
----	----------------

When "PRODUCT MODE" appears on the display, release the button and press the "power" → "ZONE2 ON/OFF" → "ZONE3 ON/OFF" button to place the product in standby mode.

7. Log Capture feature

7.1. Actions

- Acquires the Network Module log.
- The log is deleted when the Network Module is deleted.
If an error occurs, it is acquired without turning off the power of this unit.
- The log can be copied to a writable USB flash drive.
It can also be sent to a server if this unit is connected to the Internet.
- The log is stored in the root folder of the USB flash drive with the name "logs-<friendlyname>-<number>.tar.gz".
<friendlyname> indicates the friendly name and <number> indicates the sequence number.
Previous logs on the USB flash drive are not overwritten. The log is encrypted.

7.2. Starting up

While the power is on, hold down buttons "BACK" and "OPTION" for at least 3 seconds.

7.2.1. If the USB flash drive is connected after starting the unit

- (1) The log is written to the USB flash drive and "Storing Logs..." is displayed.
The log is also sent to the server.

L1	Storing Logs...
----	-----------------

- (2) When a log package is saved to a USB flash drive, "USB SUCCESS" appears in the display for 5 seconds, regardless of whether the upload to the server was successful.

L1	USB SUCCESS
----	-------------

- (3) When saving of the log package fails, "USB FAILED" appears in the display for 5 seconds, regardless of whether the upload to the server was successful.

L1	USB FAILED
----	------------

7.2.2. When the USB flash drive is not connected after startup, and this unit is connected to the Internet.

- (1) The log is sent to the server and the display shows "Storing Logs..." for 5 seconds.

L1	Storing Logs...
----	-----------------

- (2) When the log package is uploaded, the ticket numbers "Ticket No : XXXXX" and "Push ENTER" are displayed until RC or the "Enter" or "Back" button of this machine is pressed.

L1	Ticket No:XXXXX
----	-----------------

L2	Push ENTER
----	------------

- (3) If the log package upload fails, "FAILED" is displayed for 5 seconds.

L1	FAILED
----	--------

8. Protection popups

1. Overview

When the power is turned on after protection is activated, a popup will prompt you to check the connection of the speaker cables and the ventilation around the unit before taking this product to one of our service centers.

Protection popups appear when ASO or thermal protection is activated.

2. Actions

- (1) When the user turns on the power after it is turned off by ASO or thermal protection, a popup corresponding to the protection that was activated is displayed.

ASO Protection



Thermal Protection



- Speaker Relay is turned off and the volume of the main zone is set to 40 while the popup is displayed to prevent protection from being activated again.
 - The same message also scrolls through the display while the popup is displayed.
 - If an abnormality occurs again while the popup is displayed, the power will turn off as it usually does in the case of abnormalities.
- (2) To clear the popup, press the ENTER button to select OK. Otherwise, the popup disappears 40 seconds after being displayed. Speaker Relay turns on and normal operation resumes when the popup disappears.
- Protection popups are only displayed once, when the power is turned on after protection is activated. If you need to confirm the type of protection that was activated (ASO or thermal) later, use the protection history display mode.

Below is a basic flowchart of how the protection popups operate.

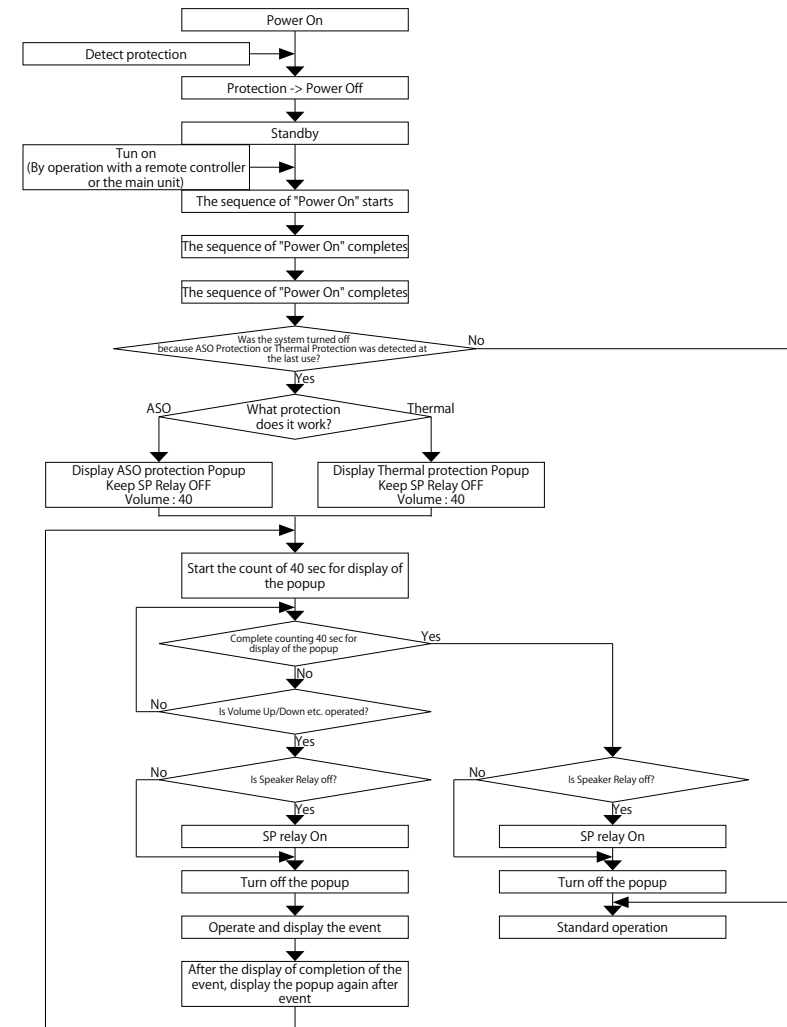

Service Path Check Mode

1.1. Actions

This function is convenient for confirming problem paths in the product and checking the paths after repairing.
The video system, audio system and fan operation paths can be checked.
The backup data is not rewritten.

1.2. Starting up

While holding down buttons "ZONE3 SOURCE" and "STATUS" simultaneously, press the power button to turn on the power.
Select the "1. SERVICE CHECK" using the "CURSOR ▼/▲" button, then press the "ENTER" button to confirm.
The "TUNED", "STEREO" and "RDS" segments are lit in this mode.

1.3. Canceling diagnostic mode

Press the power button to turn off the power.

1.4. Selecting items to check

Press the ① button to switch between video items and audio items.
Press the ② or ③ button to select the previous or next item.

Actions	The unit			Remote control unit		
	①	②	③	①	②	③
	Audio ⇄ Video ⇄ FAN	PREVIOUS	NEXT	Audio ⇄ Video ⇄ FAN	PREVIOUS	NEXT
Button	DIMMER	CURSOR ◀	CURSOR ▶	SLEEP	CURSOR ◀	CURSOR ▶

1.5. Audio system confirmation items

See the block diagram fig.AXXth.

Paths to be confirmed		Display	Settings	What to confirm
1	Analog	fig.A01 A01:ANALOG PASS	Input Source : CBL/SAT Input Mode : Analog (fixed) Sound mode : DIRECT Amp assign : 13.1ch Floor Layout : 5.1&SB Height Sp : 4ch Dolby Sp : None Height Layout : Front Height/Rear Height MAIN ZONE : On ZONE2 : Off ZONE3 : Off	<ul style="list-style-type: none"> • Analog input ⇒ Speaker output (Front L/R) • Analog input ⇒ Pre OUT output (Front L/R) (※ The input source can be switched to any source except CBL/SAT.)
2	DIGITAL (MAIN)	fig.A02a fig.A02b A2: DIGITAL	Input Source : CBL/SAT Input Mode : DIGITAL (fixed) Sound mode : MULTI CH STEREO Amp assign : 13.1ch Floor Layout : 5.1&SB Height Sp : 4ch Dolby Sp : None Height Layout : Front Height/Rear Height Speaker Select : Floor&Height Speaker Config ALL Speaker = Small/SW = Yes(2ch) MAIN ZONE : On ZONE2 : Off ZONE3 : Off	<ul style="list-style-type: none"> • Digital input ⇒ Speaker output (Front L/R, Center, Surround L/R, S.Back L/R) • Digital input ⇒ Pre OUT output (Front L/R, Center, Surround L/R, S.Back L/R, SubWoofer1/2) (※ The input source can be switched to any source except CBL/SAT.)

Paths to be confirmed		Display	Settings	What to confirm
3	DIGITAL (ZONE2)	fig.A03a fig.A03b fig.A03c	A03: DIGITAL-Z2 Input Source : HEOS Music Input Mode : Auto Sound mode : STEREO ZONE2 Source : HEOS Music Amp assign : 9.1ch + ZONE2 Speaker for ZONE2 : Height2 Floor Layout : 5ch Height Sp : 2ch Dolby Sp : None Height Layout : Front Height MAIN ZONE : On ZONE2 : On ZONE3 : Off	<ul style="list-style-type: none"> • Digital(PCM) input ⇒ Speaker output (Height2 (ZONE2) L/R) • Digital(PCM) input ⇒ Pre OUT output (ZONE2 L/R) (※ The input source can be switched to any source except HEOS Music.)
4	DIGITAL (ZONE3)	fig.A04a fig.A04b fig.A04c	A04: DIGITAL-Z3 Input Source : HEOS Music Input Mode : Auto Sound mode : STEREO ZONE2 Source : HEOS Music Amp assign : 9.1ch + ZONE3 Speaker for ZONE3 : Height3, FrontWide Floor Layout : 5ch Height Sp : 2ch Dolby Sp : None Height Layout : Front Height MAIN ZONE : On ZONE2 : Off ZONE3 : On	<ul style="list-style-type: none"> • Digital(PCM) input ⇒ Speaker output (Height3, FrontWide (ZONE3), L/R) • Digital(PCM) input ⇒ Pre OUT output (ZONE3 L/R) (※ The input source can be switched to any source except HEOS Music.)
5	HDMI	fig.A05a fig.A05b fig.A05c	A05: HDMI Input Source : CBL/SAT Input Mode : HDMI (fixed) Sound mode : STEREO Amp assign : 13.1ch Floor Layout : 5ch&SB Height Sp : 2ch Dolby Sp : None Height Layout : Front Height/Rear Height MAIN ZONE : On ZONE2 : Off ZONE3 : Off	<ul style="list-style-type: none"> • HDMI input ⇒ Speaker output (Front L/R) • HDMI input ⇒ Pre OUT output (Front L/R) (※ The input source can be switched to any source except CBL/SAT.)
6	Analog AD (MAIN ZONE)	fig.A06a fig.A06b	A06: AD Input Source : CBL/SAT Input Mode : Analog (fixed) Sound mode : MULTI CH STEREO Amp assign : 13.1ch Floor Layout : 5ch&SB Height Sp : 4ch Dolby Sp : None Height Layout : Front Height/Rear Height Speaker Select : Floor&Height Speaker Config ALL Speaker = Small/SW = Yes(2ch) MAIN ZONE : On ZONE2 : Off ZONE3 : Off	<ul style="list-style-type: none"> • Analog input ⇒ Speaker output (Front L/R, Center, Surround L/R, S.Back L/R, Height1 L/R) • Analog input ⇒ Pre OUT output, SW(20Hz) (Front L/R, Center, Surround L/R, S.Back L/R, SubWoofer) (※ The input source can be switched to any source except CBL/SAT.) (※ Volume 60 is the value when Absolute settings are used. The value is -20 when Relative settings are used)
7	Analog Amp Assign (Amp Assign : ZONE2)	fig.A07	A07: ASSIGN-Z2 Input Source : CBL/SAT Input Mode : Auto Sound mode : STEREO ZONE2 Source : CBL/SAT(select a setting other than Source) Amp assign : 9.1ch + ZONE2 Speaker for ZONE2 : Height2 Floor Layout : 5ch Height Sp : 4ch Dolby Sp : None Height Layout : Front Height/Rear Height MAIN ZONE : On ZONE2 : On ZONE3 : Off	<ul style="list-style-type: none"> • Analog input ⇒ Speaker output (Height2 (ZONE2) L/R) • Analog input ⇒ Pre OUT output (ZONE2 L/R) (※ The input source can be switched to any source except CBL/SAT.) (※ Volume 60 is the value when Absolute settings are used. The value is -20 when Relative settings are used)

Paths to be confirmed		Display	Settings	What to confirm
8	Analog Amp Assign (Amp Assign : ZONE3)	fig.A08	A08:ASSIGN-Z3 Input Source : CBL/SAT Input Mode : Auto Sound mode : STEREO ZONE3 Source : CBL/SAT(select a setting other than Source) Amp assign : 9.1ch + ZONE3 Speaker for ZONE3 : Height3, FrontWide Floor Layout : 5ch Height Sp : 2ch Dolby Sp : None Height Layout : Front Height/Rear Height MAIN ZONE : On ZONE2 : Off ZONE3 : On	<ul style="list-style-type: none"> Analog input ⇒ Speaker output (Height3, FrontWide (ZONE3), L/R) Analog input ⇒ Pre OUT output (ZONE3 L/R) (※ The input source can be switched to any source except CBL/SAT.) (※ Volume 60 is the value when Absolute settings are used. The value is -20 when Relative settings are used)
9	Analog Amp Assign (Amp Assign : ZONE2/ZONE3- MONO)	fig.A09	A09:ASSIGN-Z2/3M Input Source : CBL/SAT Input Mode : Auto Sound mode : STEREO ZONE2 Source : Source : CBL/SAT(select a setting other than Source) ZONE3 Source : Source : CBL/SAT (select a setting other than Source) Amp assign : 9.1ch + ZONE2/3-MONO Speaker for ZONE2/3 : Height2 Floor Layout : 5ch&SB Height Sp : 2ch Dolby Sp : None Height Layout : Front Height/Rear Height MAIN ZONE : On ZONE2 : On ZONE3 : On	<ul style="list-style-type: none"> Analog input ⇒ Speaker output (Height2 (ZONE2 MONO L), Height2 (ZONE3 MONO) R) Analog input ⇒ Pre OUT output (ZONE2 L/R MONO, ZONE3 L/R MONO) (※ The input source can be switched to any source except CBL/SAT.) (※ Volume 60 is the value when Absolute settings are used. The value is -20 when Relative settings are used)
10	Amp Assign (Amp Assign : BiAMP)	fig.A10a fig.A10b	A11:ASSIGN-BiAMP Input Source : CBL/SAT Input Mode : Auto Sound mode : MULTI CH STEREO Amp assign : 9.1ch + BiAMP Speaker for Bi-Amp : S.Back Floor Layout : 5ch Height Sp : 4ch Dolby Sp : None Height Layout : Front Height/Rear Height MAIN ZONE : On ZONE2 : Off ZONE3 : Off	<ul style="list-style-type: none"> Analog input ⇒ Speaker output (S.Back L/R) (※ The input source can be switched to any source except CBL/SAT.) (※ Volume 60 is the value when Absolute settings are used. The value is -20 when Relative settings are used)
11	Front Height	fig.A11a fig.A11b	A14:FRONT HEIGHT Input Source : CBL/SAT Input Mode : Auto Sound mode : MULTI CH STEREO Amp assign : 13.1ch Floor Layout : 5ch&SB Height Sp : 6ch Dolby Sp : None Height Layout : Top Front & Top Rear TopMiddle Top Rear Pre-out channel : Top Middle Speaker Select = Floor & Height MAIN ZONE : On ZONE2 : Off ZONE3 : Off	<ul style="list-style-type: none"> Analog input ⇒ Speaker output (Height1 L/R (Top Front), Height2 L/R (Top Rear)) Analog input ⇒ Pre OUT output (Height1 L/R (Top Front), Height2 L/R (Top Rear), Height3 L/R (TopMiddle)) Pre OUT output (※ The input source can be switched to any source except CBL/SAT.) (※ Volume 60 is the value when Absolute settings are used. The value is -20 when Relative settings are used)
12	Front Wide	fig.A12a fig.A12b	A15:FRNT WIDE Input Source : CBL/SAT Input Mode : Auto Sound mode : MULTI CH STEREO Amp assign : 13.1ch Floor Layout : 5ch&FW Height Sp : 4ch Dolby Sp : None Height Layout : Front Height Rear Height Pre-out channel : Rear Height Speaker Select = Floor & Height MAIN ZONE : On ZONE2 : Off ZONE3 : Off	<ul style="list-style-type: none"> Analog input ⇒ Speaker output (Height3 L/R (Front Wide)) Analog input ⇒ Pre OUT output (Height3 L/R (Front Wide)) Pre OUT output (※ The input source can be switched to any source except CBL/SAT.) (※ Volume 60 is the value when Absolute settings are used. The value is -20 when Relative settings are used)

Paths to be confirmed		Display	Settings	What to confirm
13	ZONE2 Downmix (Amp Assign : ZONE2)	fig.A13a fig.A13b	A22:Z2 Downmix Input Source : CBL/SAT Input Mode : Auto Sound mode : STEREO ZONE2 Source : Source Amp assign : 9.1ch + ZONE2 Speaker for ZONE2 : Height2 Floor Layout : 5ch Height Sp : 2ch Dolby Sp : None Height Layout : Front Height MAIN ZONE : ON ZONE2 : On ZONE3 : Off	<ul style="list-style-type: none"> • Analog input ⇒ Speaker output (Height2 (ZONE2) L/R) • Analog input ⇒ Pre OUT output (ZONE2 L/R) (※ The input source for ZONE2 can be switched to any source except CBL or SAT.) (Do not change the input source for Zone2 from "SOURCE".) (※ Volume 60 is the value when Absolute settings are used. The value is -20 when Relative settings are used)

1.6. Confirmation items for the video system

See the block diagram fig.VXXth.

Paths to be confirmed		Display	Settings	What to confirm
1	Analog Video pass	fig.V01	V01:VIDEO PASS Input Source : DVD Video Convert (IP Scaler) : "OFF" All sources MAIN ZONE : On ZONE2 : On ZONE3 : Off	<ul style="list-style-type: none"> • CVBS input ⇒ CVBS output • Component input ⇒ Component output (※ The input source can be switched to any source except CBL/SAT.)
2	Video Convert (Analog or HDMI ⇒ HDMI)	fig.V02	V02:V.CONVERT Input Source : CBL/SAT Video Conversion (IP Scaler) : "ON" All sources IP Scaler : "Analog & HDMI", All sources Resolution : "Auto", All sources MAIN ZONE : On ZONE2 : Off ZONE3 : Off	<ul style="list-style-type: none"> • CVBS input ⇒ IP Scaler ⇒ HDMI output. • Component input ⇒ IP Scaler ⇒ HDMI output. • HDMI input ⇒ IP Scaler ⇒ HDMI output. • HEOS input ⇒ IP Scaler ⇒ HDMI output. (※ The input source can be switched to any source except CBL/SAT.)
3	HDMI pass (MAIN ZONE)	fig.V03	V03:HDMI PASS Input Source : CBL/SAT Video Convert (IP Scaler) : "OFF" All sources MAIN ZONE : On ZONE2 : Off ZONE3 : Off	<ul style="list-style-type: none"> • HDMI input (MAIN function) ⇒ HDMI output (MAIN) (※ The input source can be switched to any source except CBL/SAT.)
4	HDMI CEC (Control Monitor : HDMI Monitor1)	fig.V04	V04:HDMI CEC Input Source : CBL/SAT HDMI Control : On MAIN ZONE : On ZONE2 : Off ZONE3 : Off	<ul style="list-style-type: none"> • When the power supply of a TV is put in the standby mode, make sure that the power supply of this unit is also put in the standby mode. (※ The input source can be switched to any source except CBL/SAT.) • The ARC path can also be checked (check this using the TV input source).
5	HDMI Audio (Audio : AVR)	fig.V05a fig.V05b fig.V05c	V05:H-AUDIO-AVR Input Source : CBL/SAT HDMI Control : Off HDMI Audio : AVR (if checking the audio output from AVR)	<ul style="list-style-type: none"> • HDMI input (PCM, DolbyDigital, DTS) ⇒ Speaker output. • HDMI input(HD audio) ⇒ Speaker output. (※ The input source can be switched to any source except CBL/SAT.)
6	HDMI Audio (Audio : TV)	fig.V06a fig.V06b	V06:H.AUDIO-TV Input Source : CBL/SAT HDMI Control : Off HDMI Audio : TV (if checking the audio output from TV)	<ul style="list-style-type: none"> • HDMI input (PCM, DolbyDigital, DTS) ⇒ HDMI output (audio output from connected TV) (※ The input source can be switched to any source except CBL/SAT.)
7	GUI	fig.V07	V07:GUI MENU ON Input Source : CBL/SAT Video Conversion (IP Scaler) : ON, All sources IP Scaler : "Analog & HDMI", All sources Resolution : "AUTO", All sources Setup Menu : On MAIN ZONE : On ZONE2 : Off ZONE3 : Off	<ul style="list-style-type: none"> • GUI display ⇒ HDMI output. (※ The input source can be switched to any source except CBL/SAT.)
8	HDMI pass (ZONE2)	fig.V08	V08:ZONE2 HDMI Input Source : CBL/SAT ZONE2 Source : Source MAIN ZONE : On ZONE2 : On ZONE3 : Off	<ul style="list-style-type: none"> • HDMI input (ZONE2 Function) ⇒ HDMI output (ZONE2) (※ The input source can be switched to any source except CBL/SAT.)

1.7. Confirmation items for fan operation

Paths to be confirmed		Display	Settings	What to confirm
1	Low-speed fan	- F01:FAN LOW	FAN CONT_LOW = HIGH FAN CONT_MID = LOW FAN CONT_HIGH = LOW MAIN ZONE : On ZONE2 : Off ZONE3 : Off	• Low-speed fan
2	Medium-speed fan	- F02:FAN MID	FAN CONT_LOW = LOW FAN CONT_MID = HIGH FAN CONT_HIGH = LOW MAIN ZONE : On ZONE2 : Off ZONE3 : Off	• Medium-speed fan
3	High-speed fan	- F03:FAN HIGH	FAN CONT_LOW = LOW FAN CONT_MID = LOW FAN CONT_HIGH = HIGH MAIN ZONE : On ZONE2 : Off ZONE3 : Off	• High-speed fan

fig.A02b



Before Servicing
This Unit

Electrical

Mechanical

Repair Information

Updating

fig.A03b

AVR-X6700/SR8015 DIGITAL AUDIO/NETWORK BLOCK DIRAGRAM

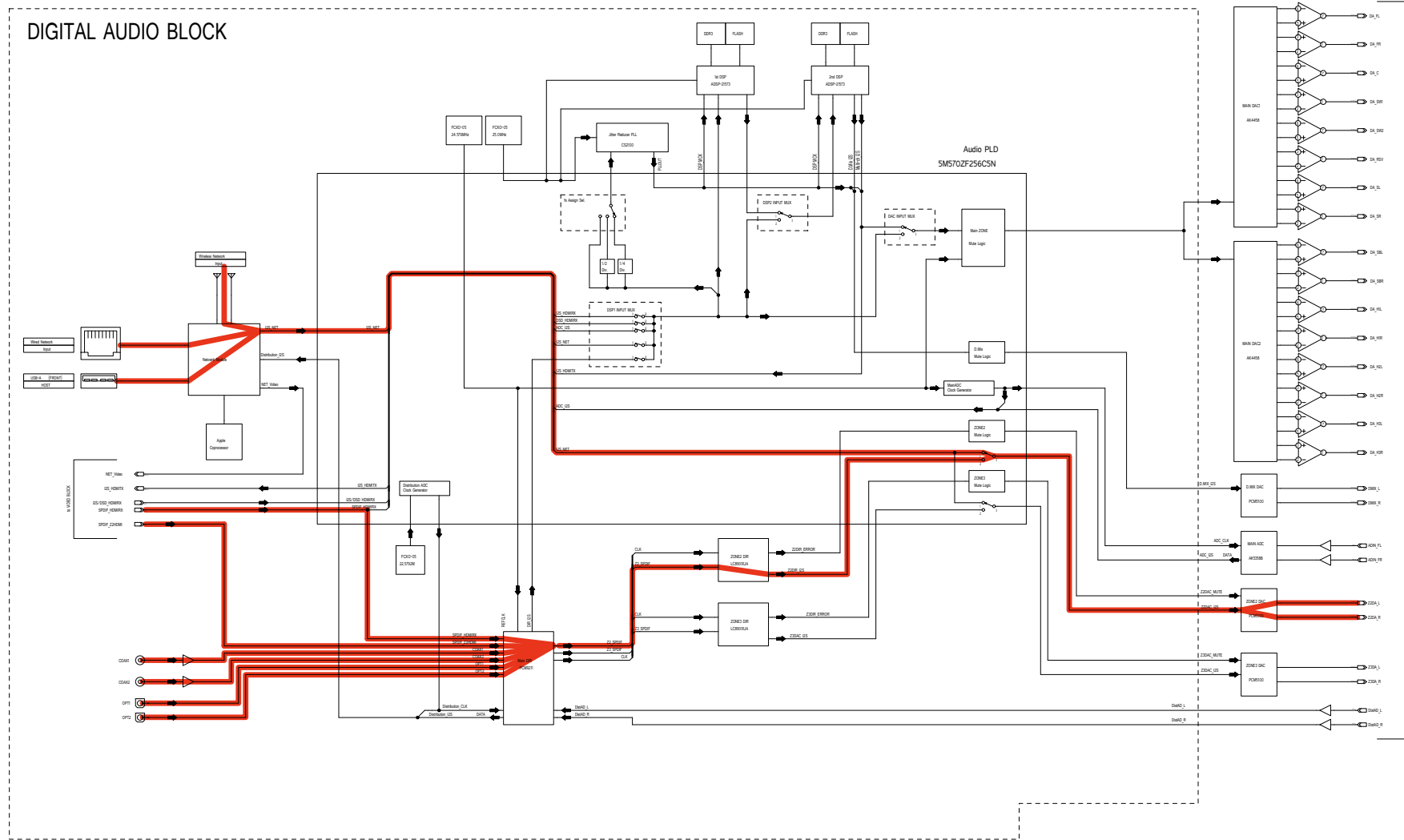
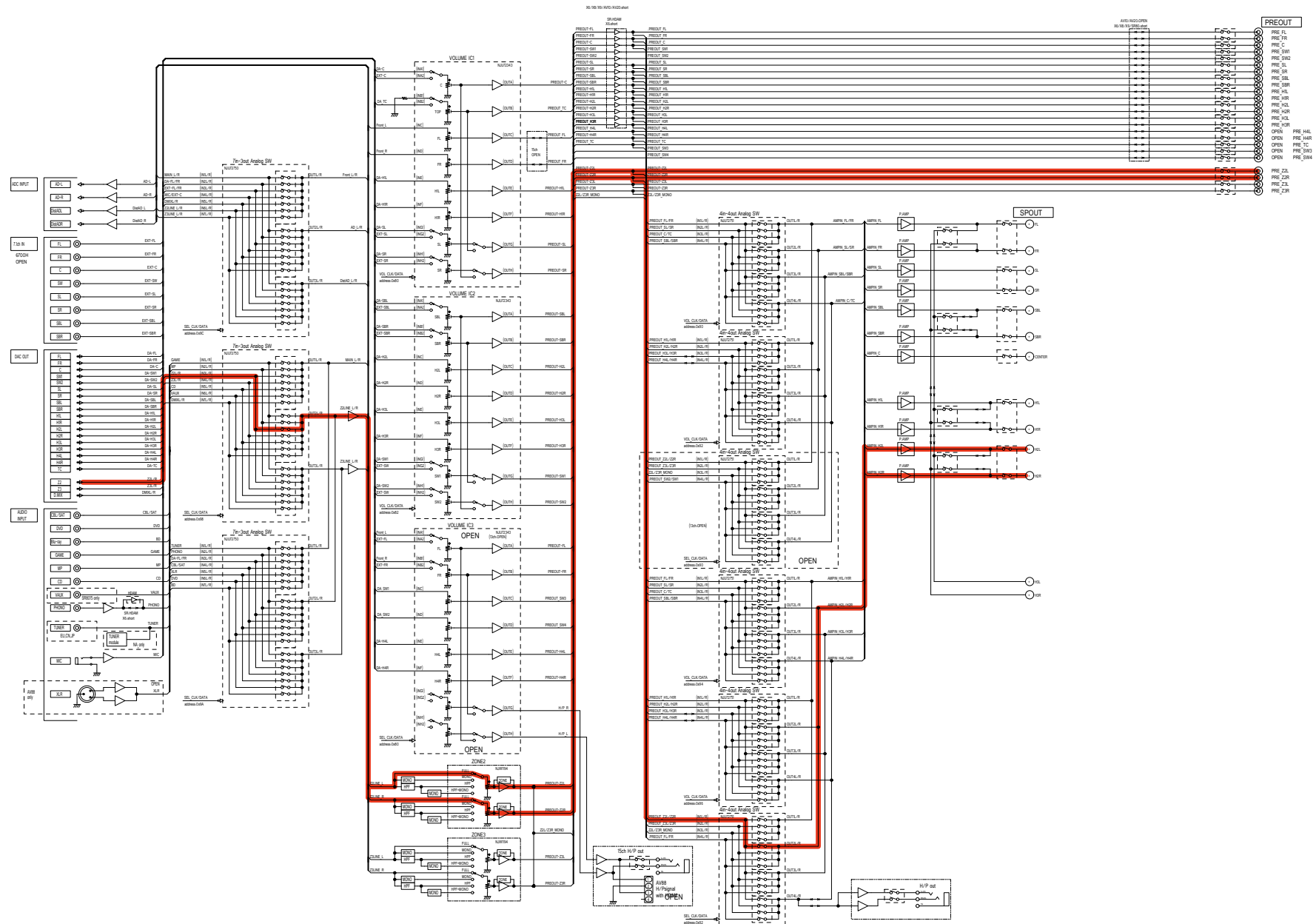

fig.A03c



Before Servicing
This Unit

Electrical

Mechanical

Repair Information

Updating

fig.A04a

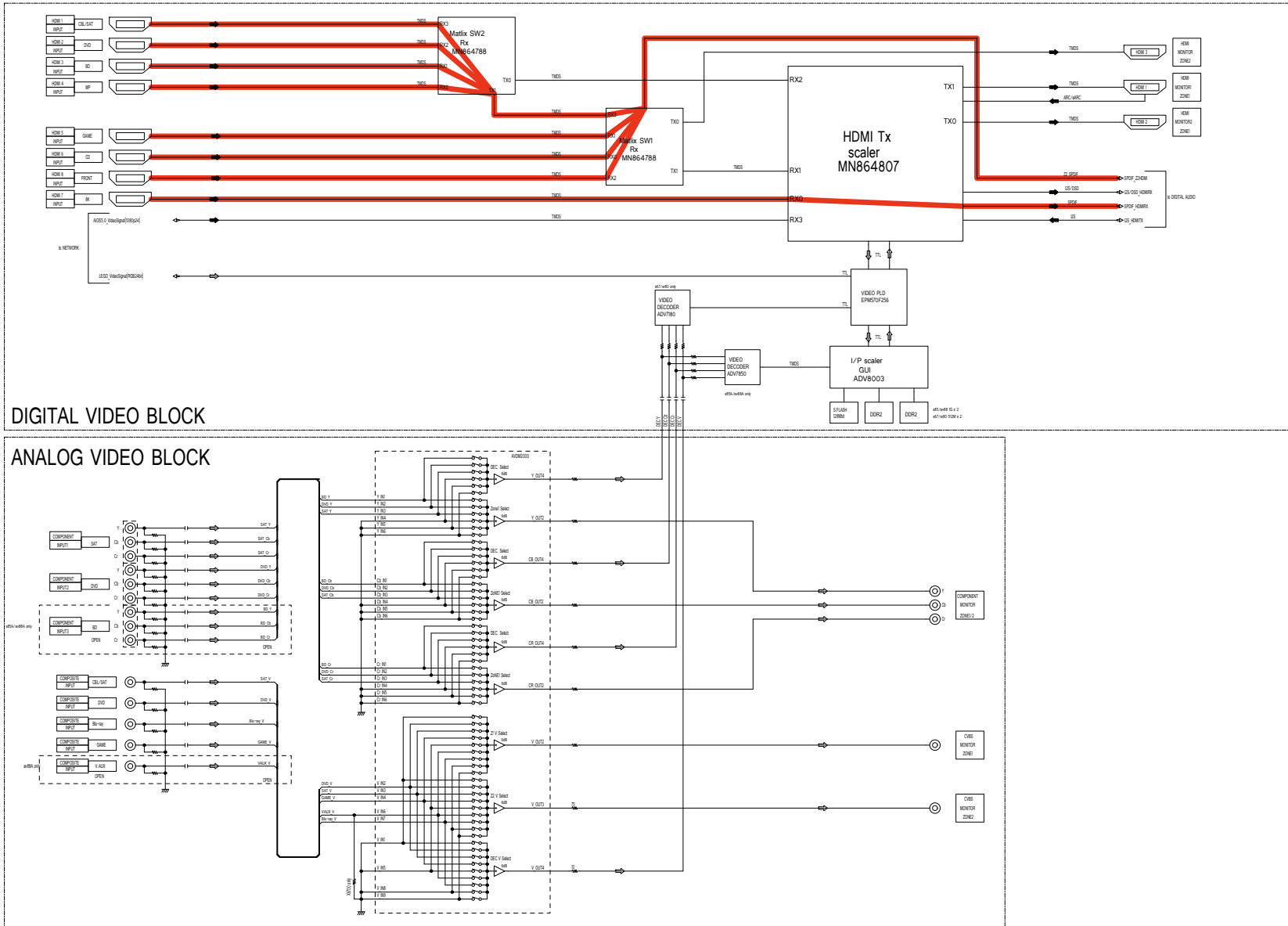

fig.A04b

AVR-X6700/SR8015 DIGITAL AUDIO/NETWORK BLOCK DIRAGRAM

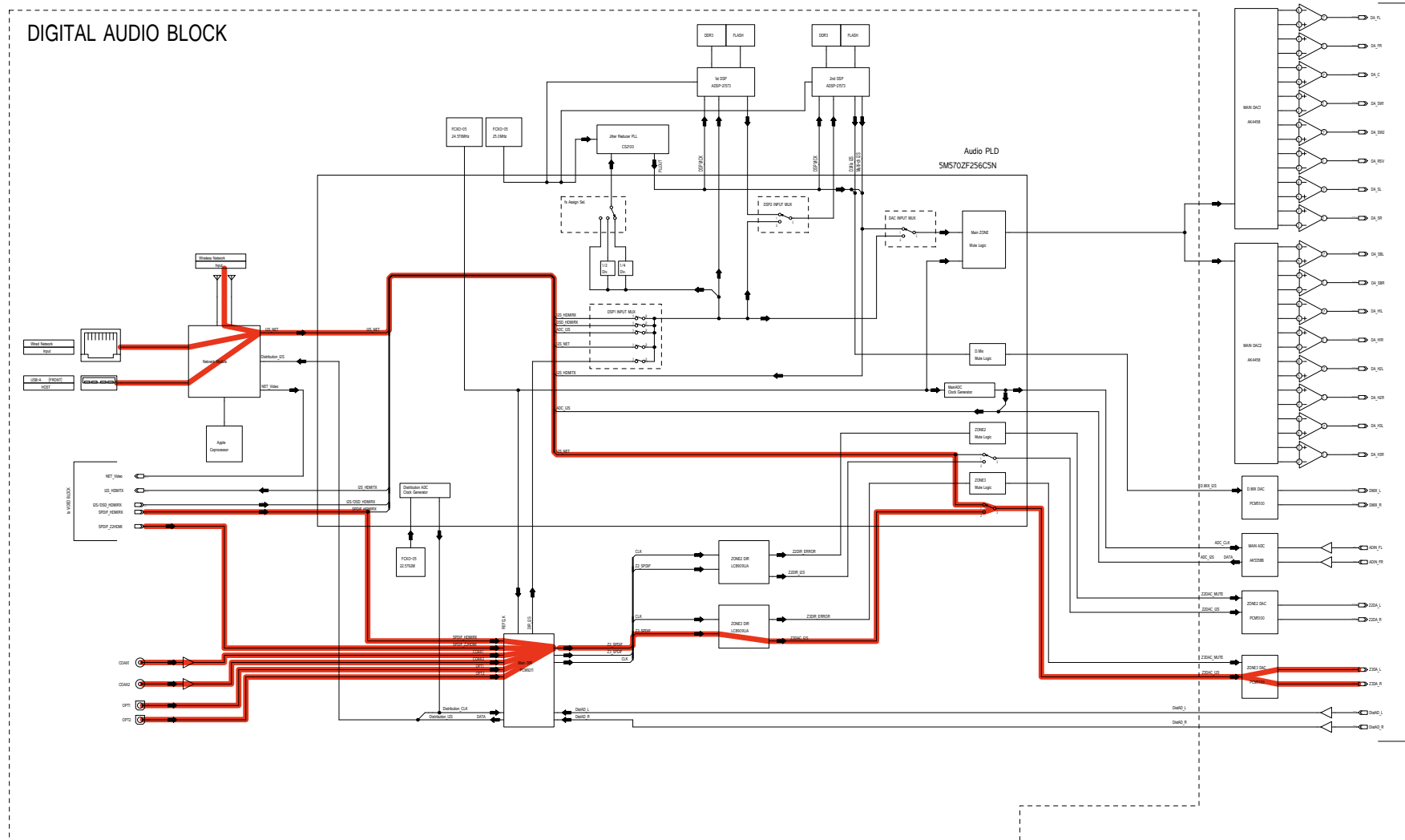

fig.A04c

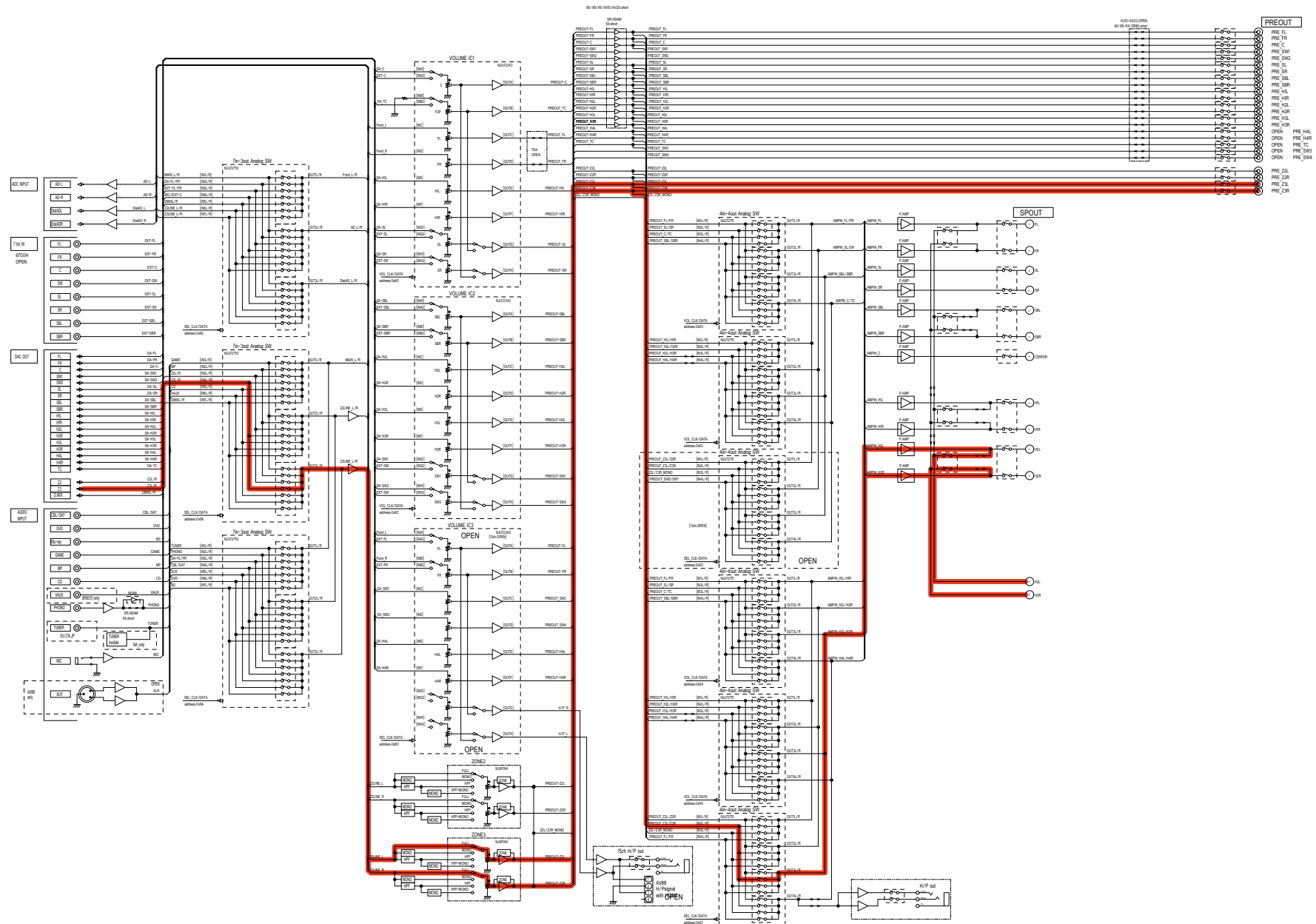

fig.A05a

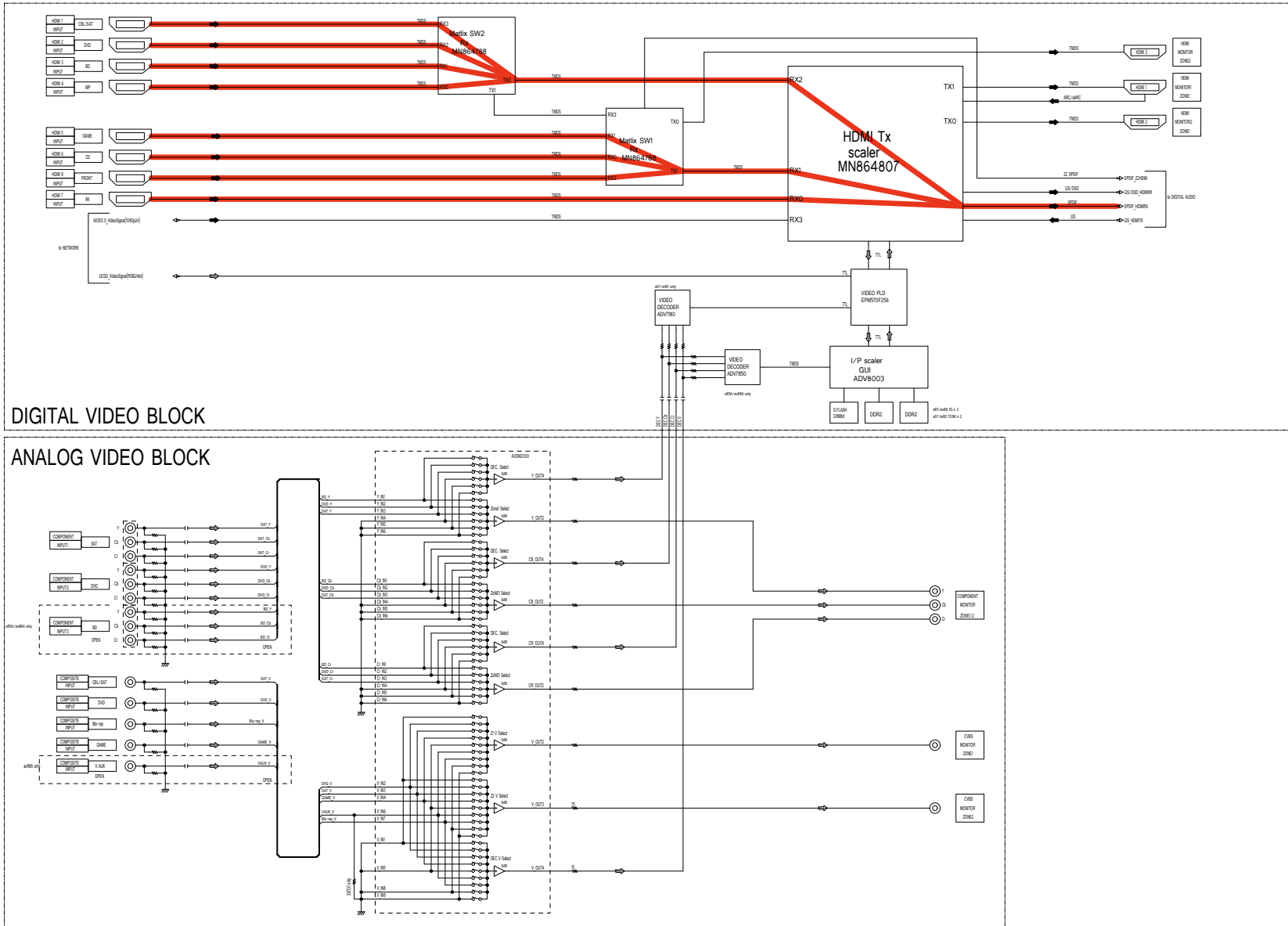

fig.A05b

AVR-X6700/SR8015 DIGITAL AUDIO/NETWORK BLOCK DIRAGRAM

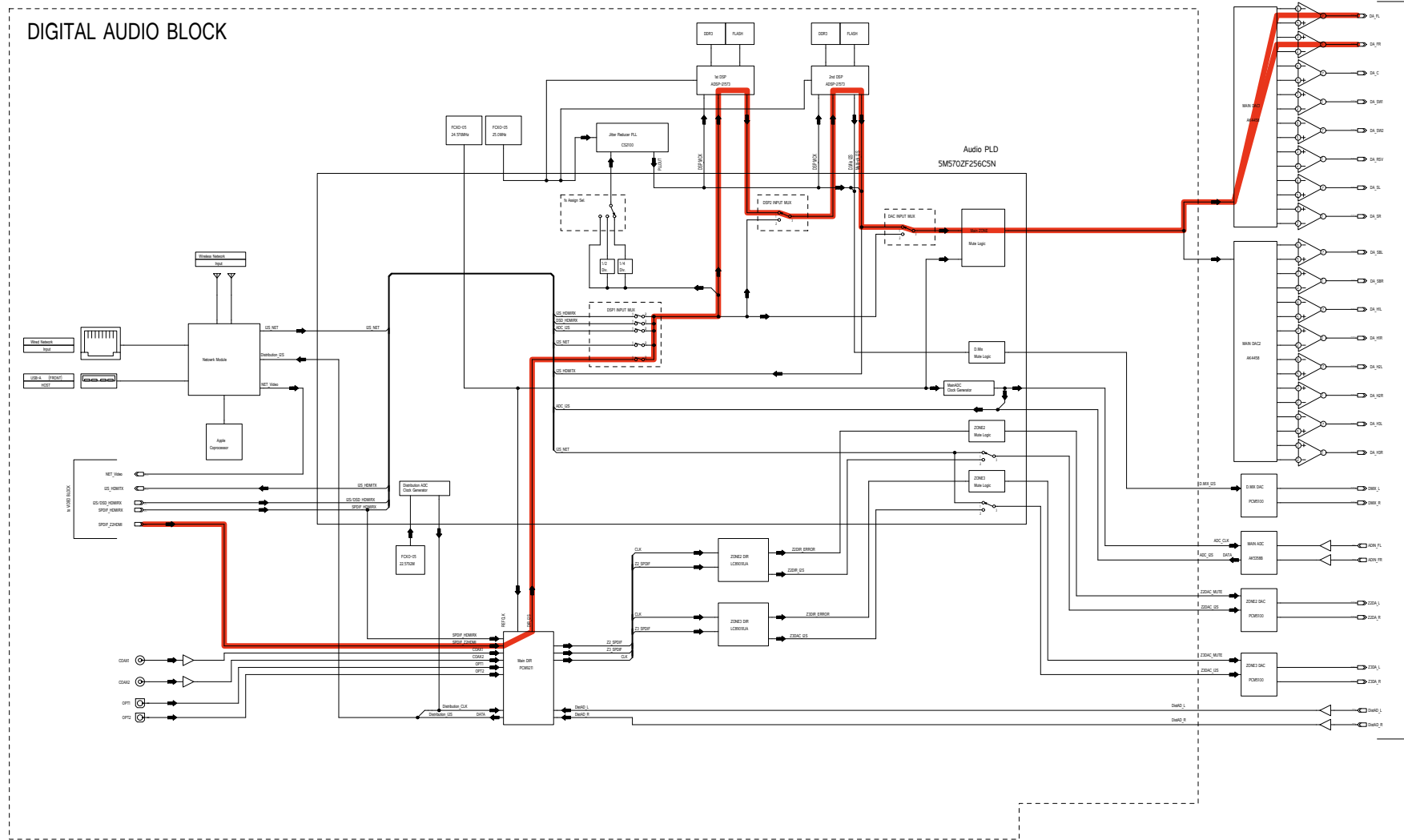

fig.A05c

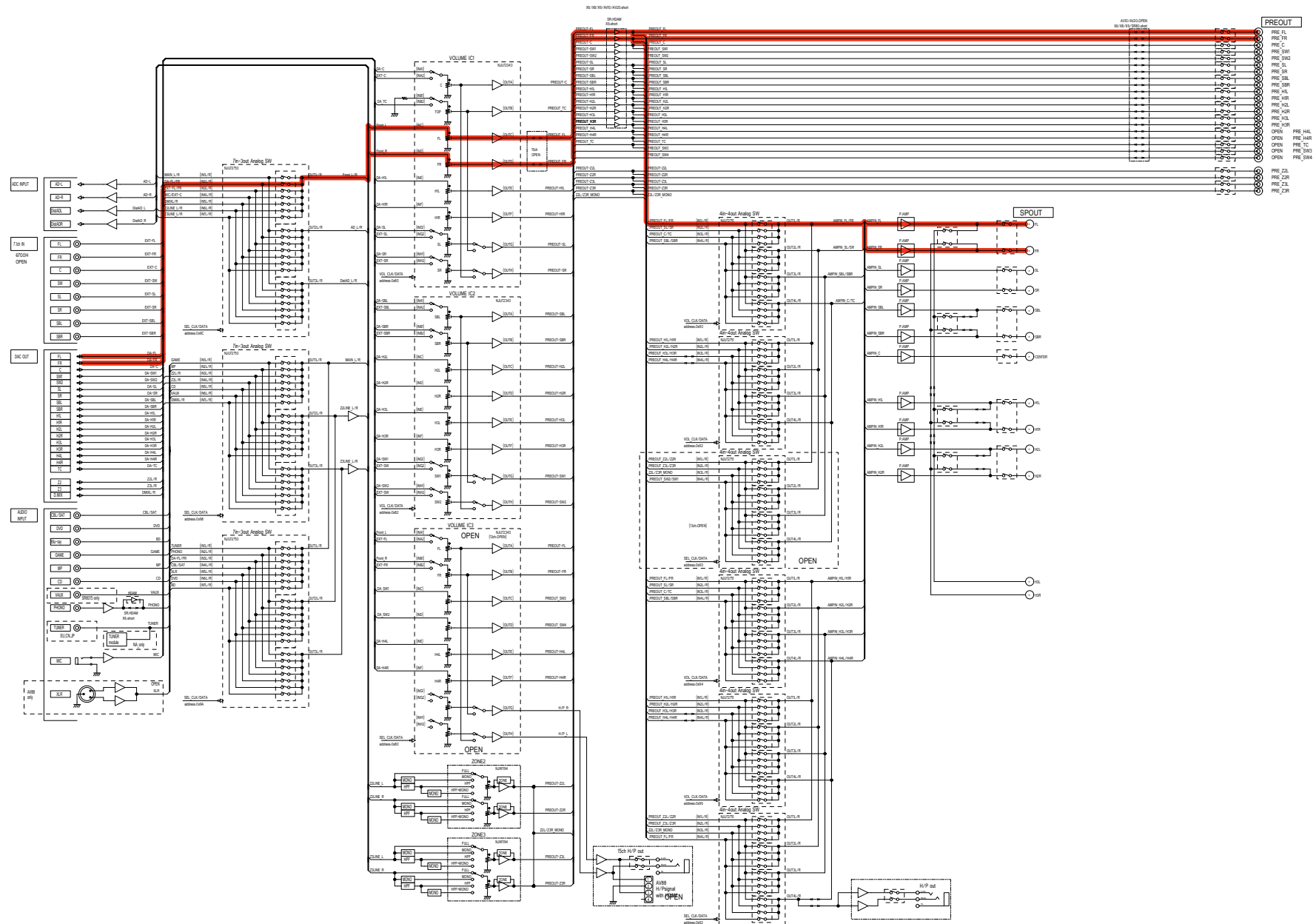

fig.A06a

AVR-X6700/SR8015 DIGITAL AUDIO/NETWORK BLOCK DIRAGRAM

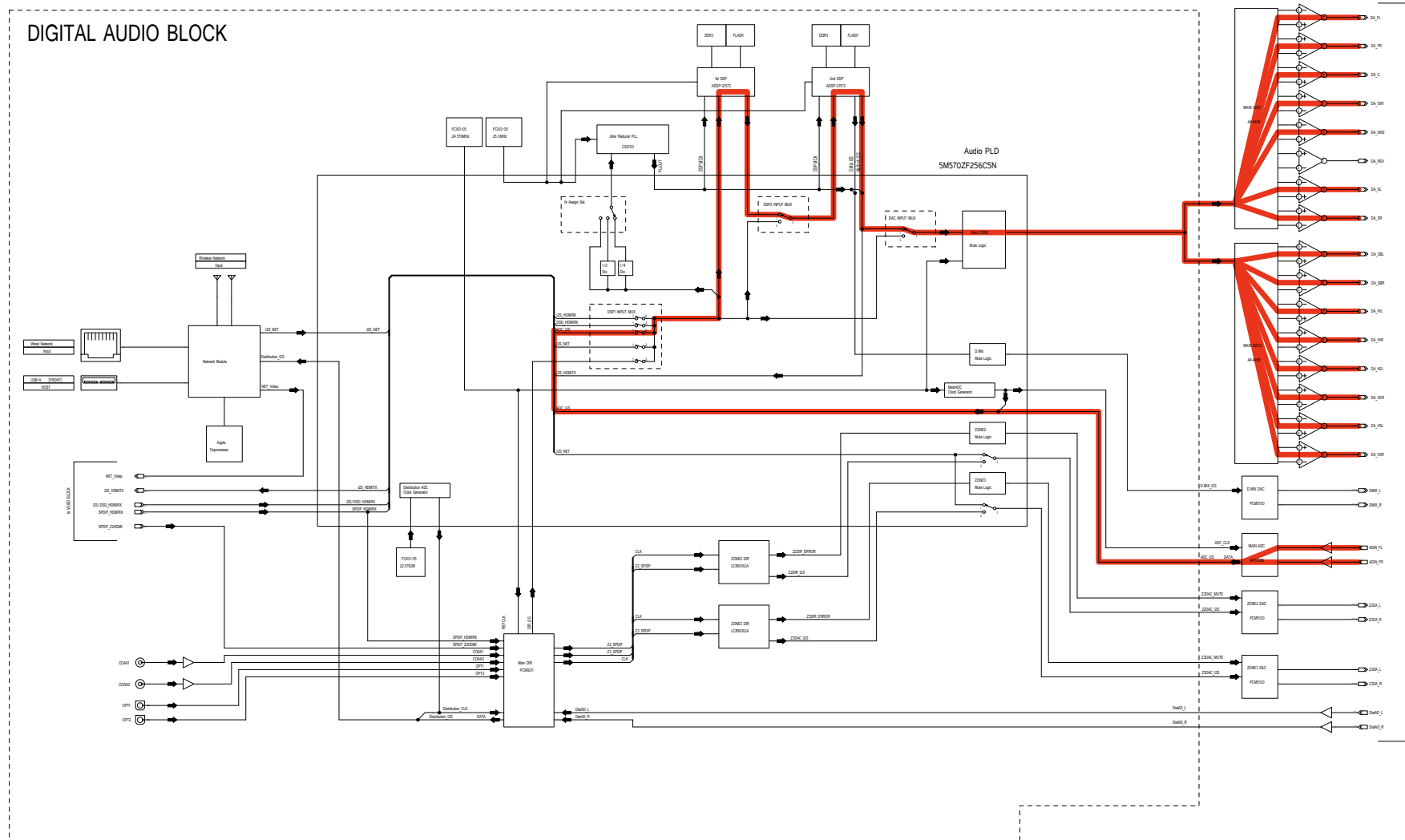

fig.A08

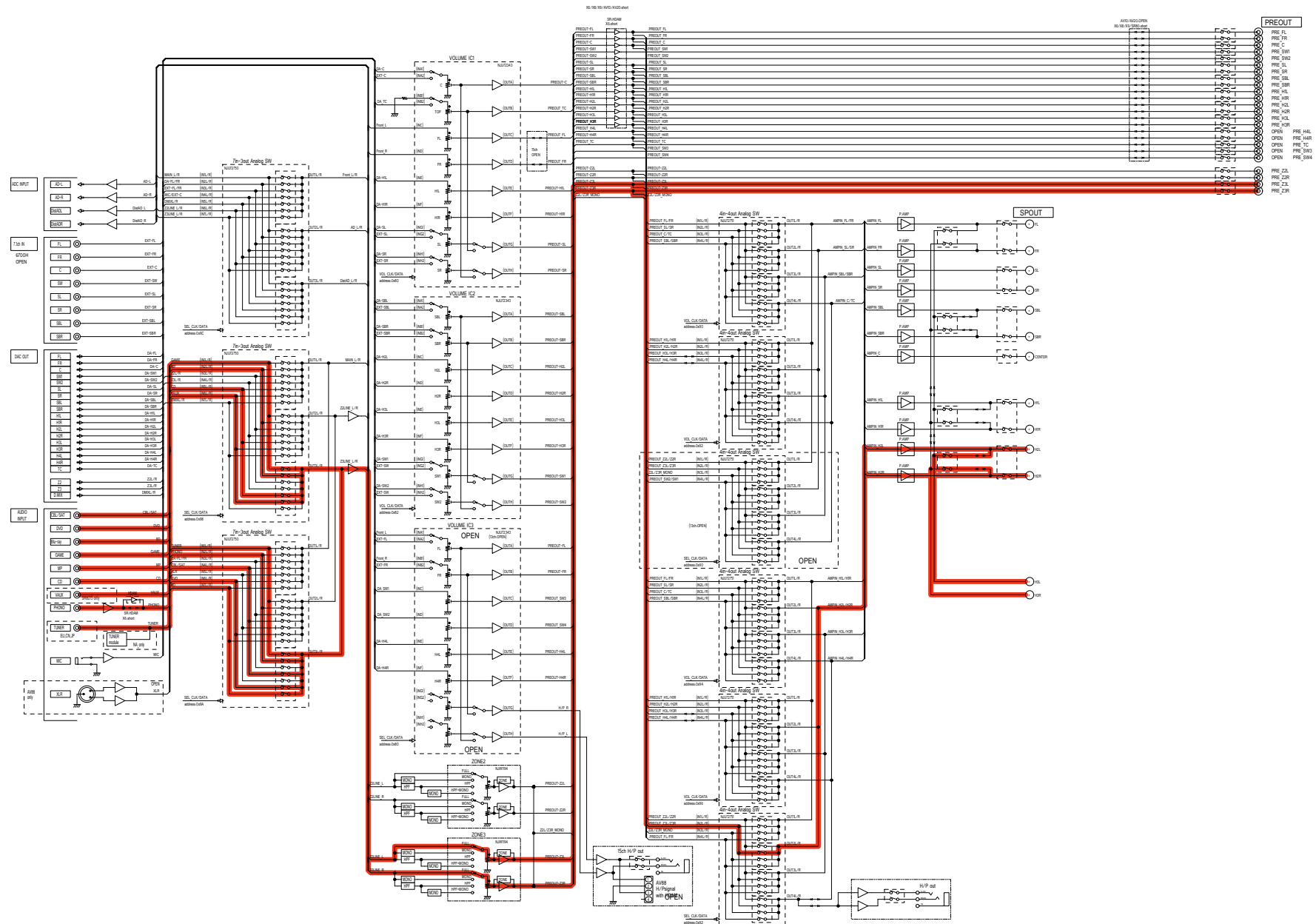

fig.A09

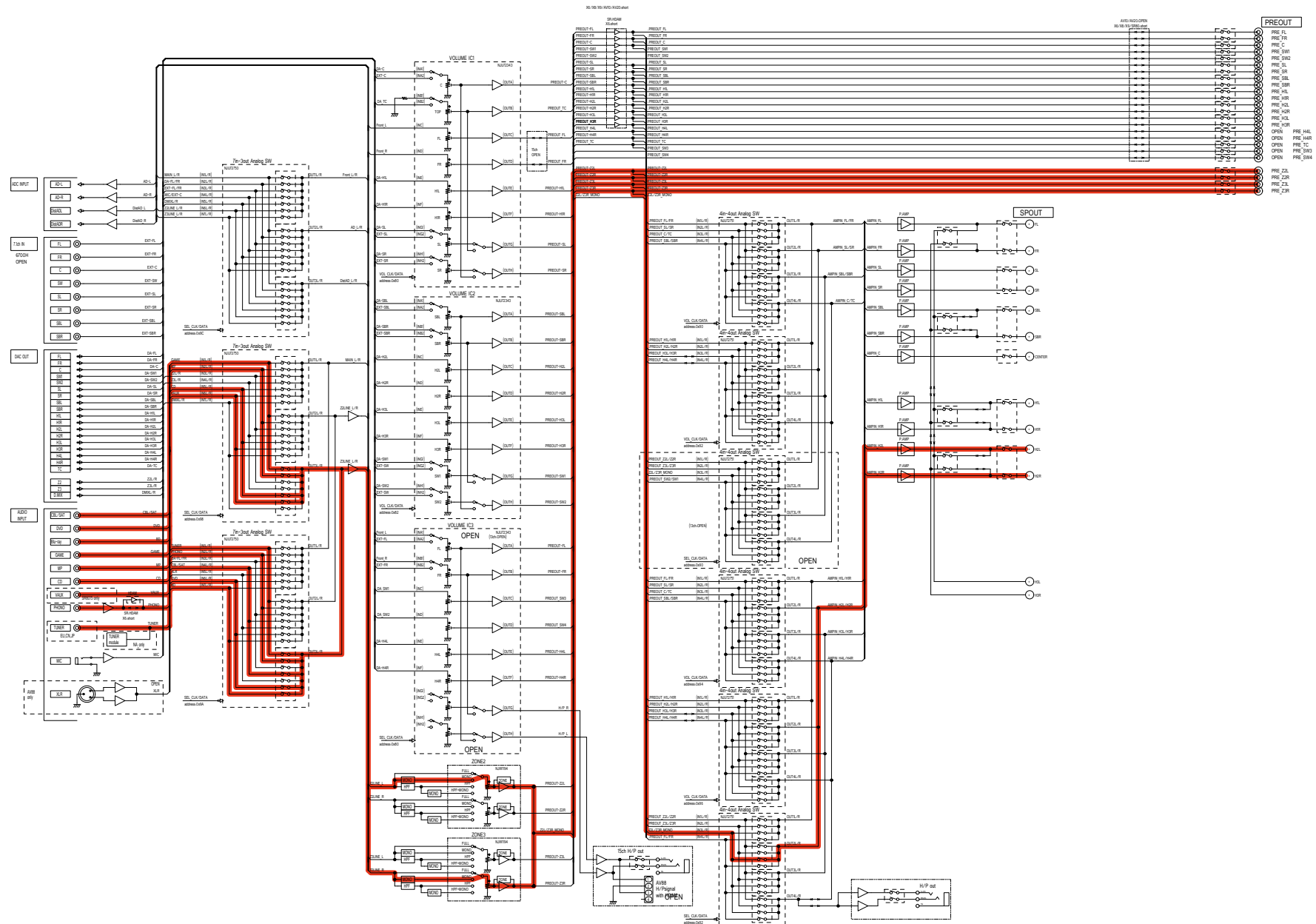

fig.A10a

AVR-X6700/SR8015 DIGITAL AUDIO/NETWORK BLOCK DIRAGRAM

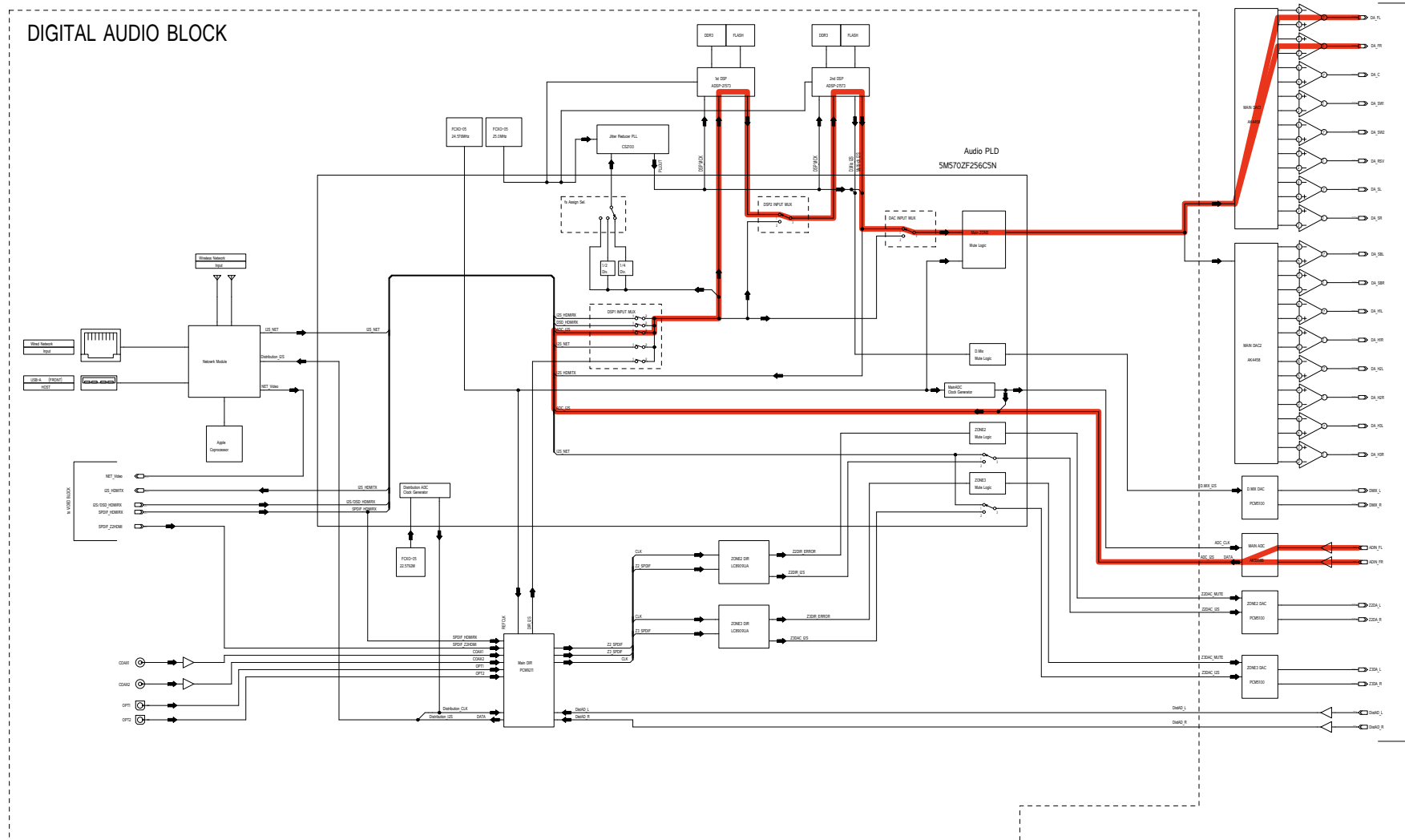

fig.A10b

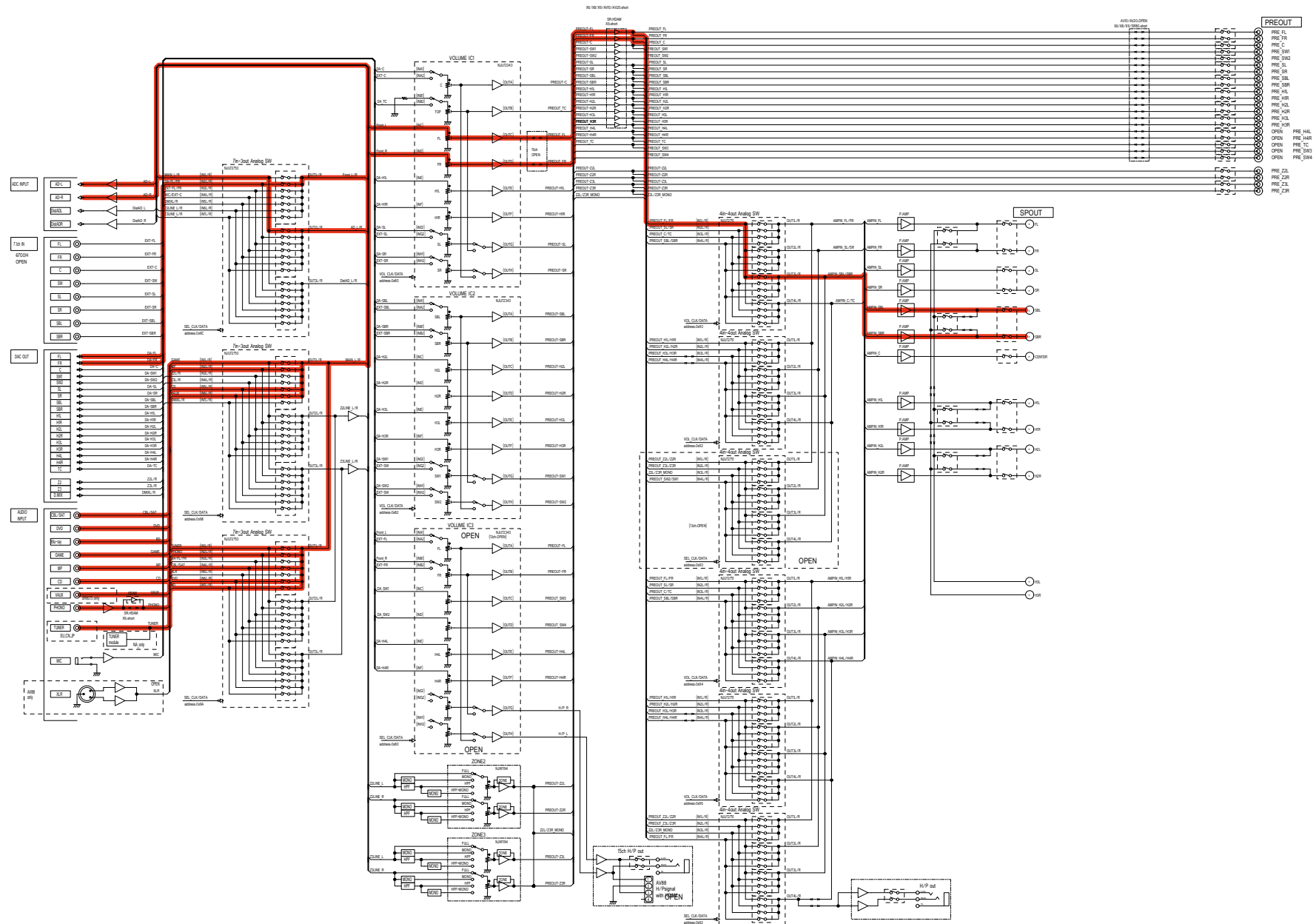

fig.A11a

AVR-X6700/SR8015 DIGITAL AUDIO/NETWORK BLOCK DIRAGRAM

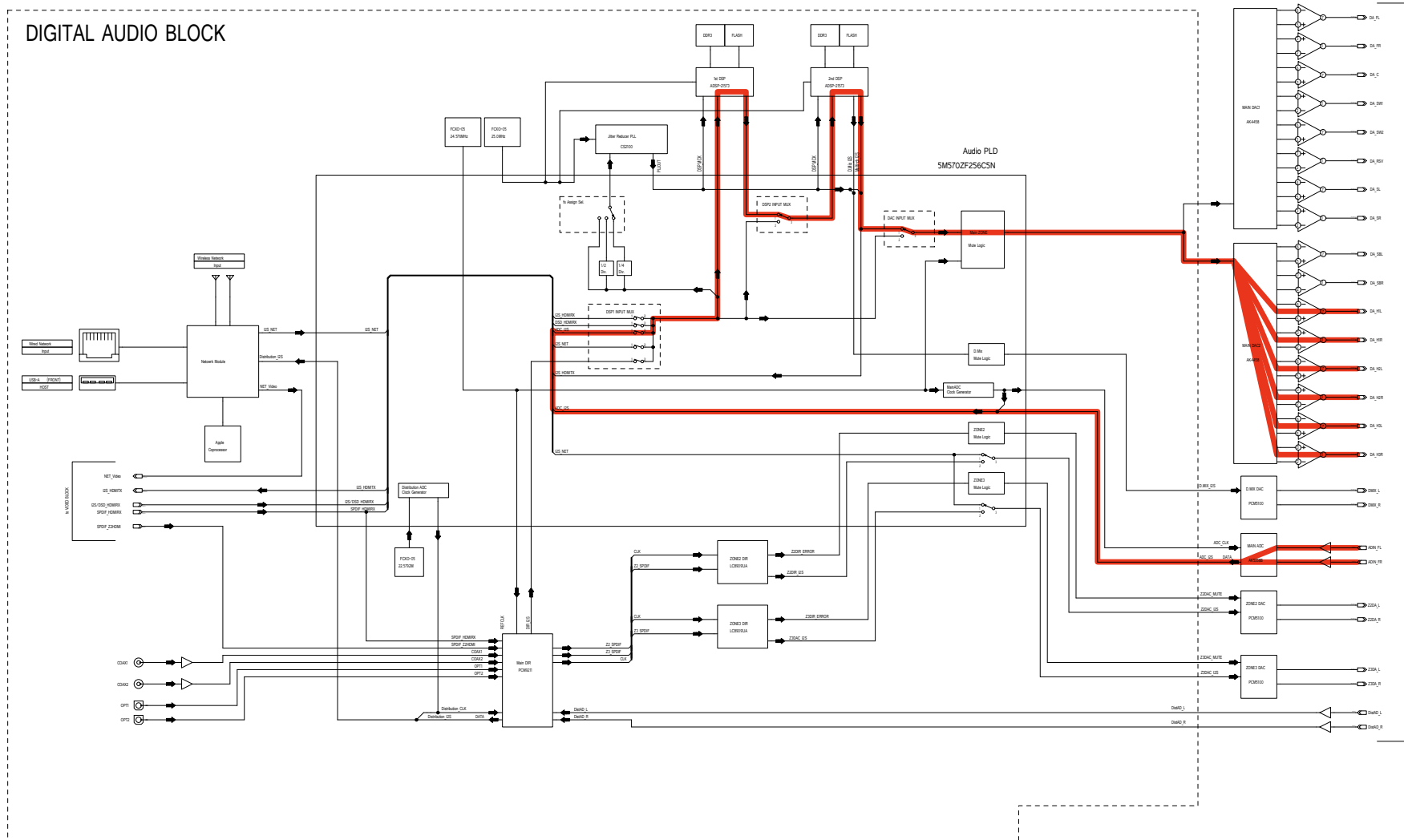
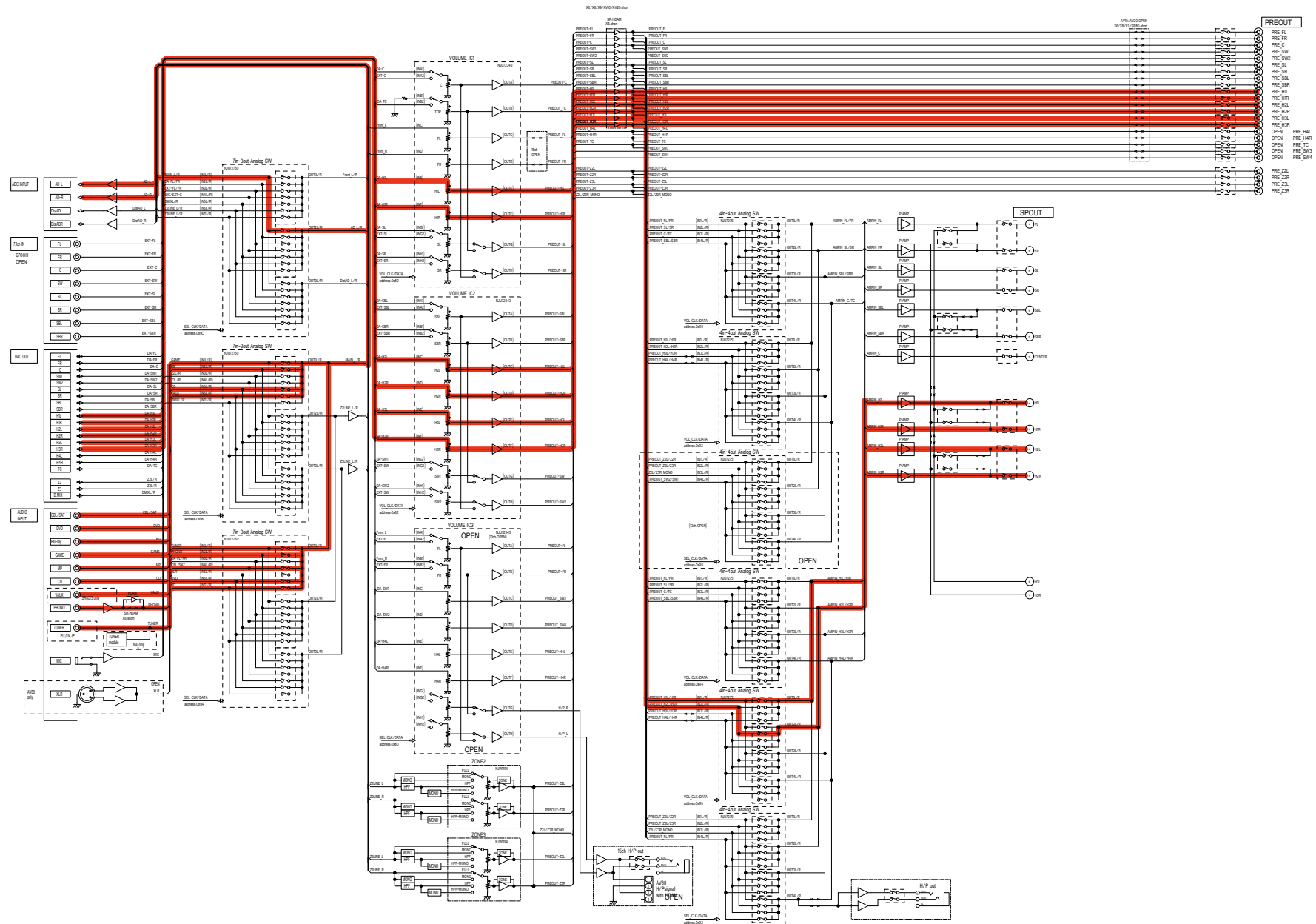

fig.A11b



Before Servicing
This Unit

Electrical

Mechanical

Repair Information

Updating

fig.A12a

AVR-X6700/SR8015 DIGITAL AUDIO/NETWORK BLOCK DIRAGRAM

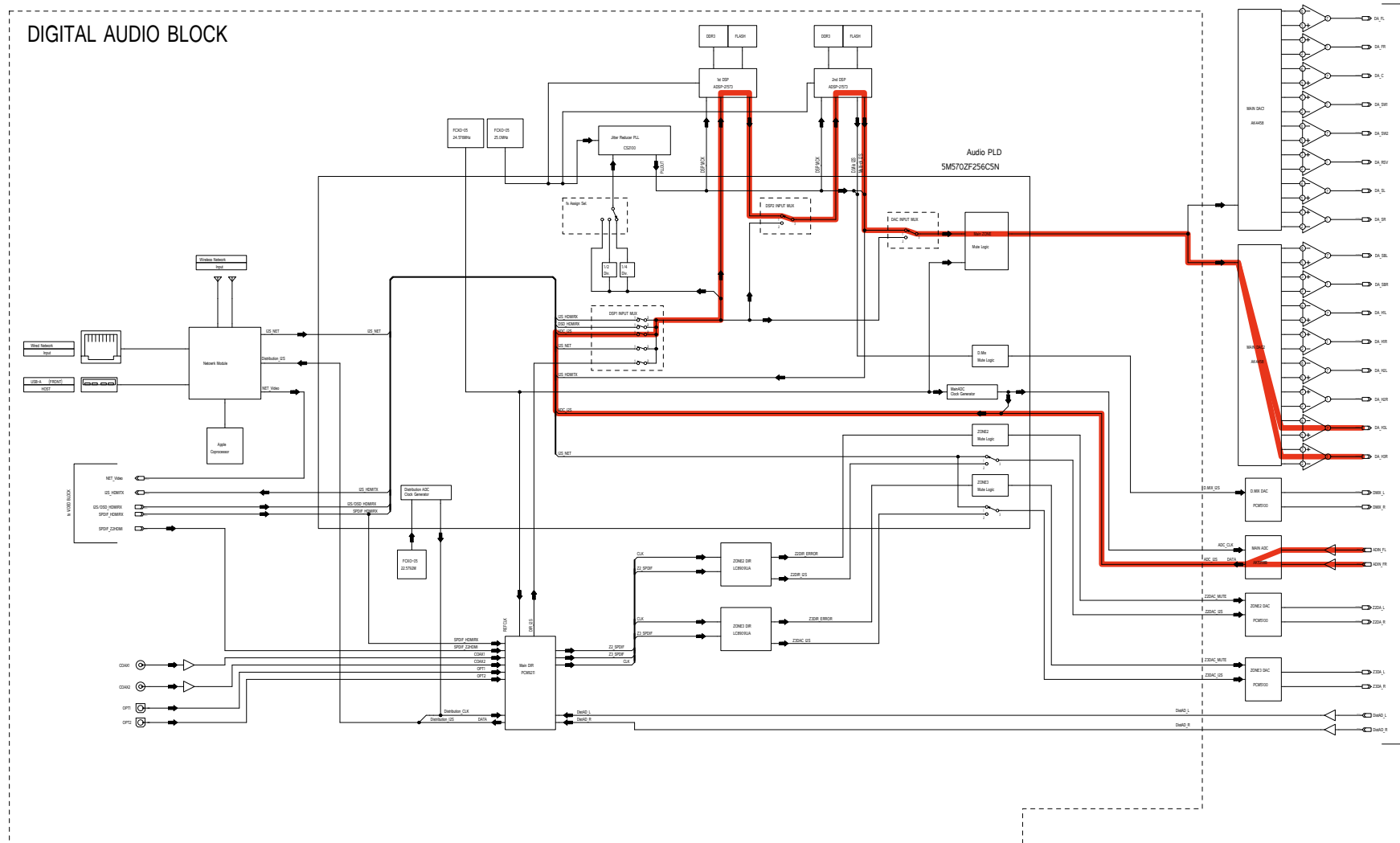

Before Servicing
This Unit

Electrical

Mechanical

Repair Information

Updating

fig.A12b

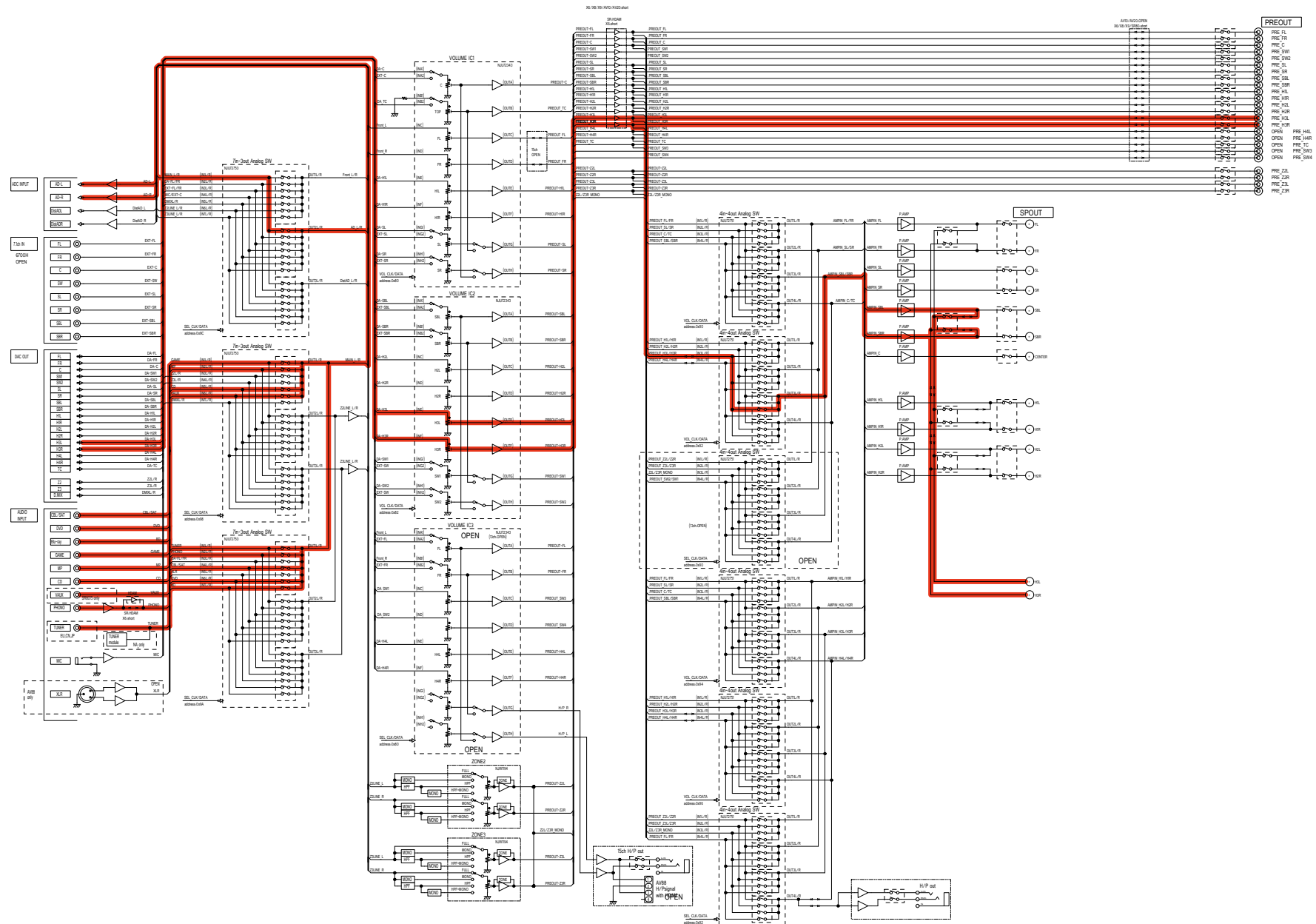

fig.A13a

AVR-X6700/SR8015 DIGITAL AUDIO/NETWORK BLOCK DIRAGRAM

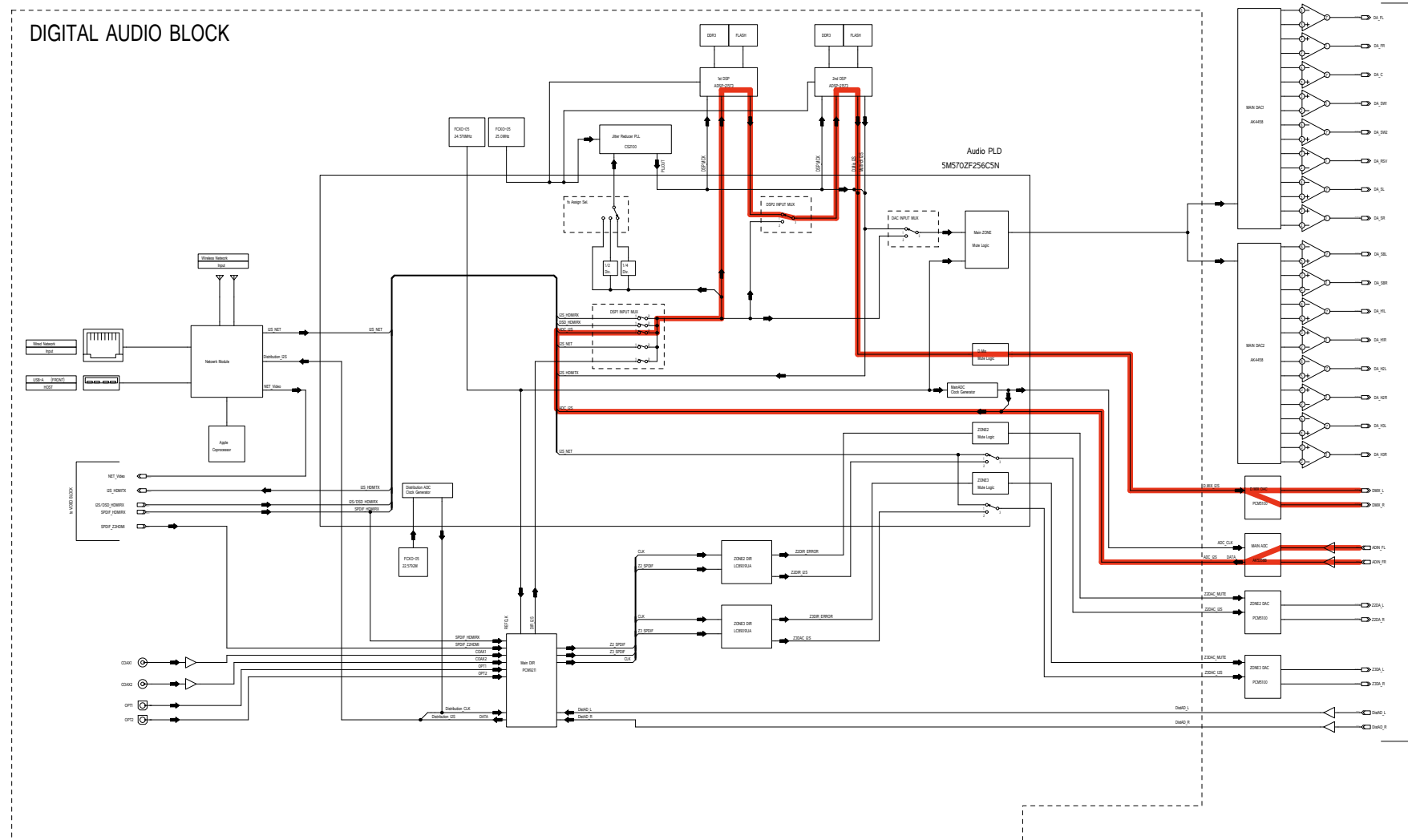

fig.A13b

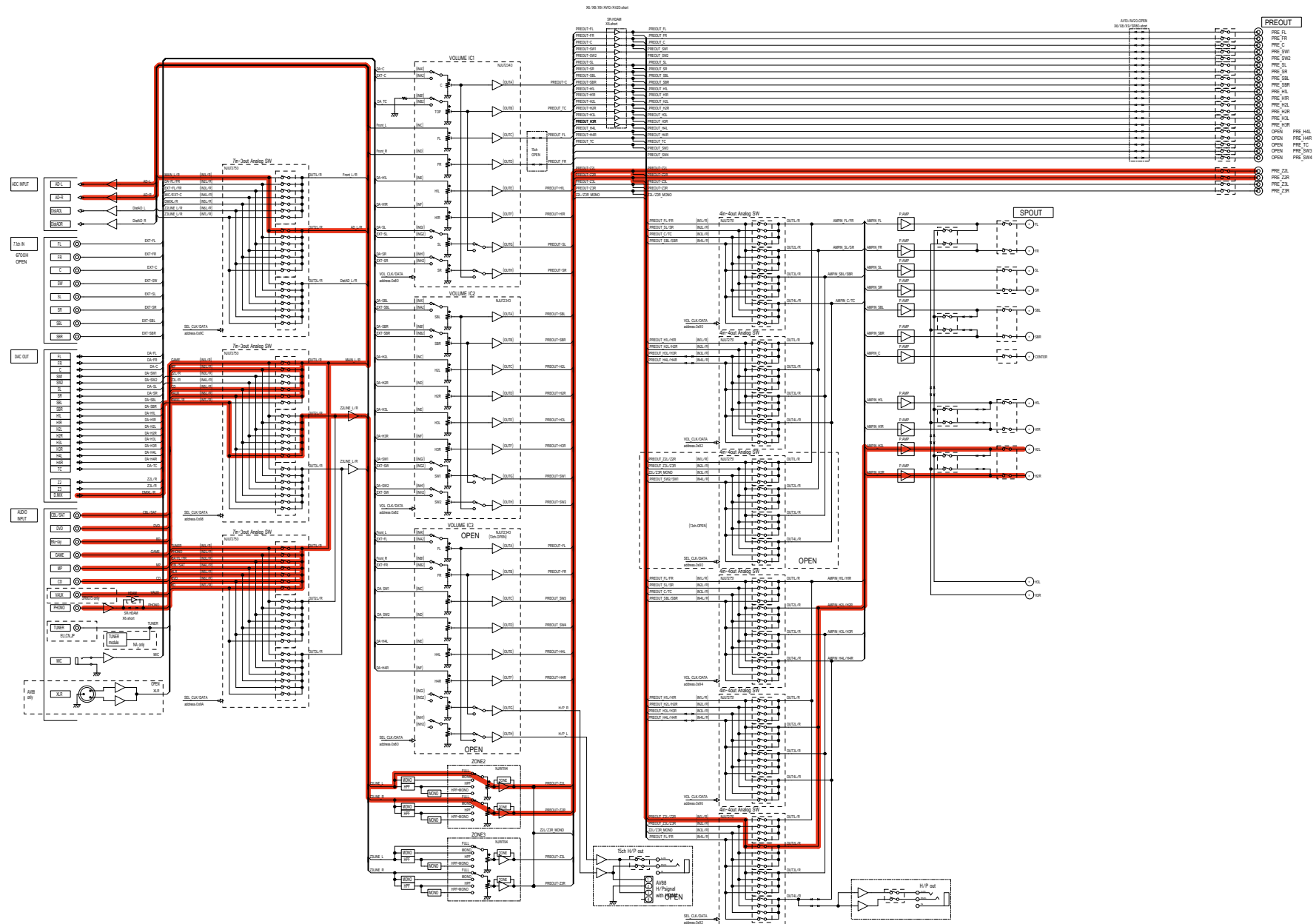
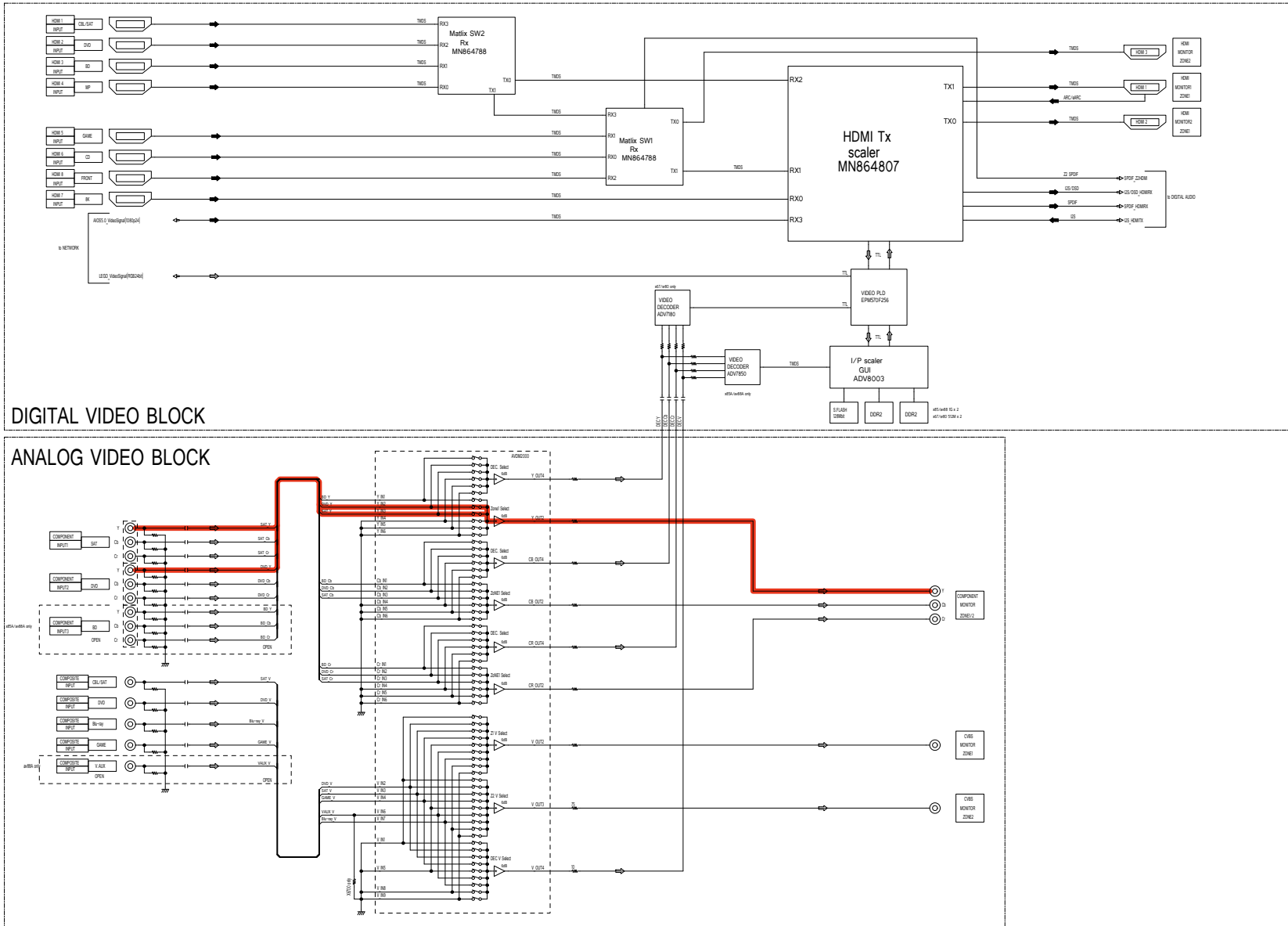

fig.V01



Before Servicing
This Unit

Electrical

Mechanical

Repair Information

Updating

fig.V02

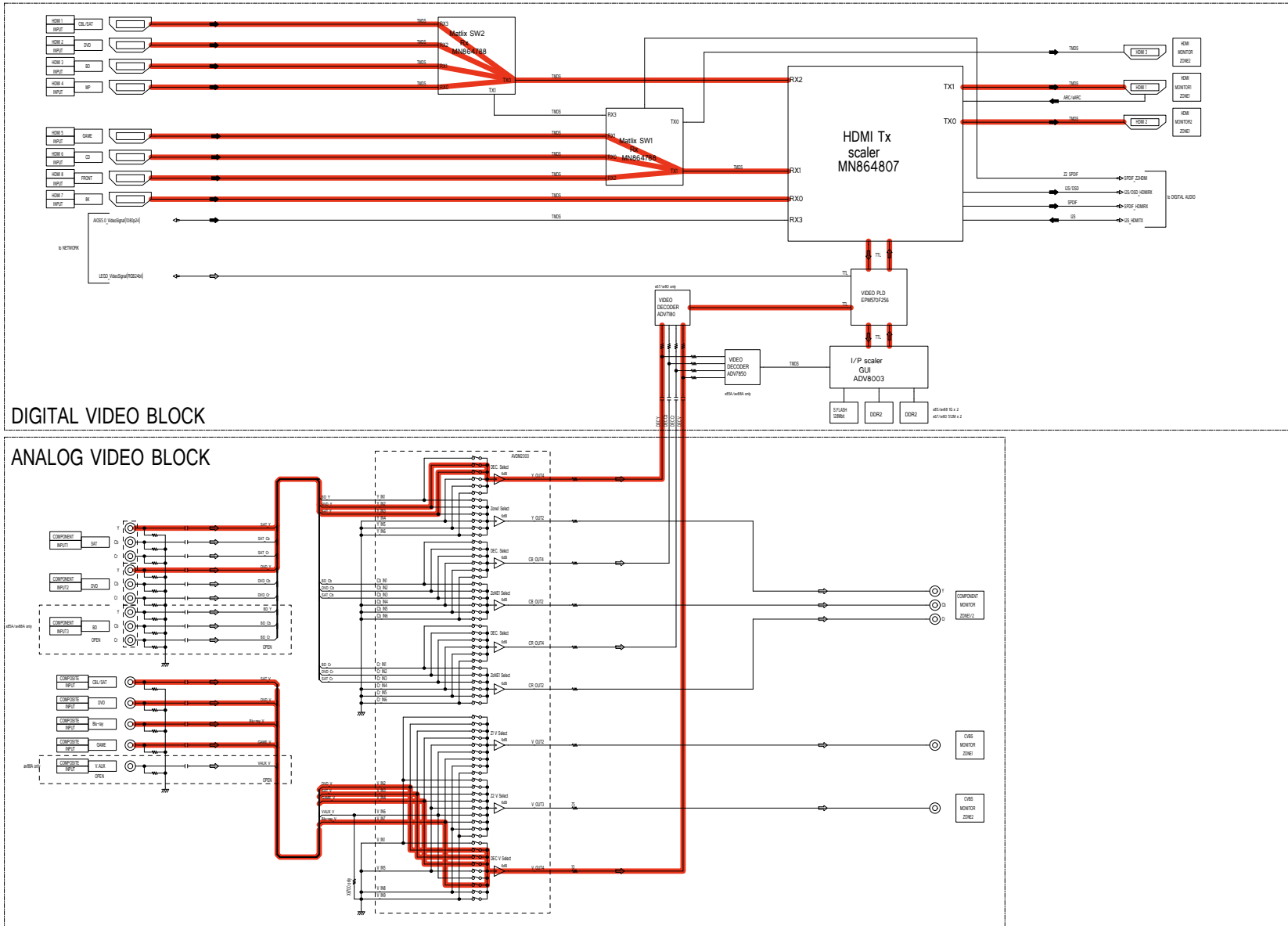

Before Servicing
This Unit

Electrical

Mechanical

Repair Information

Updating

fig.V03

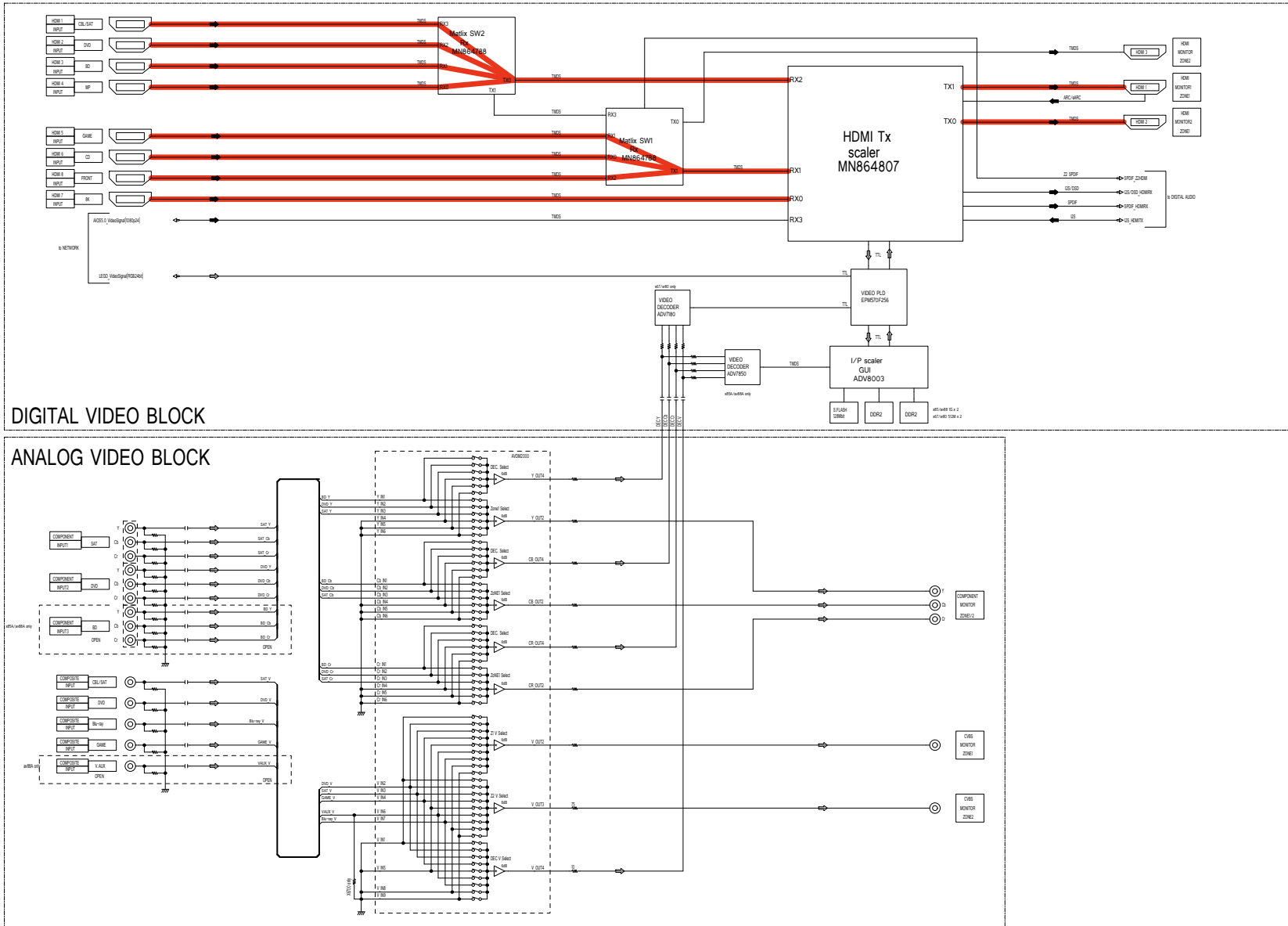

Before Servicing
This Unit

Electrical

Mechanical

Repair Information

Updating

fig.V04

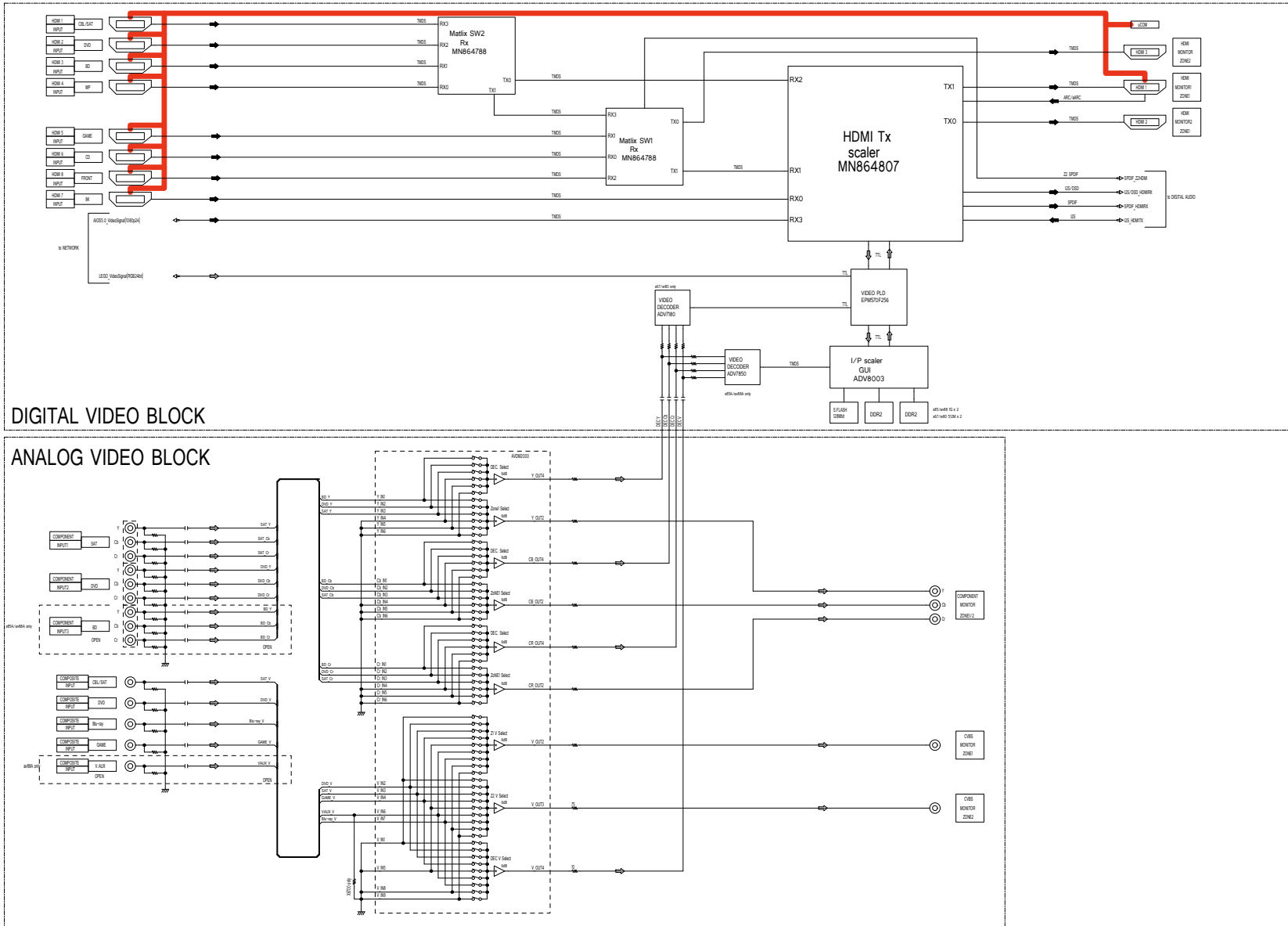

fig.V05a

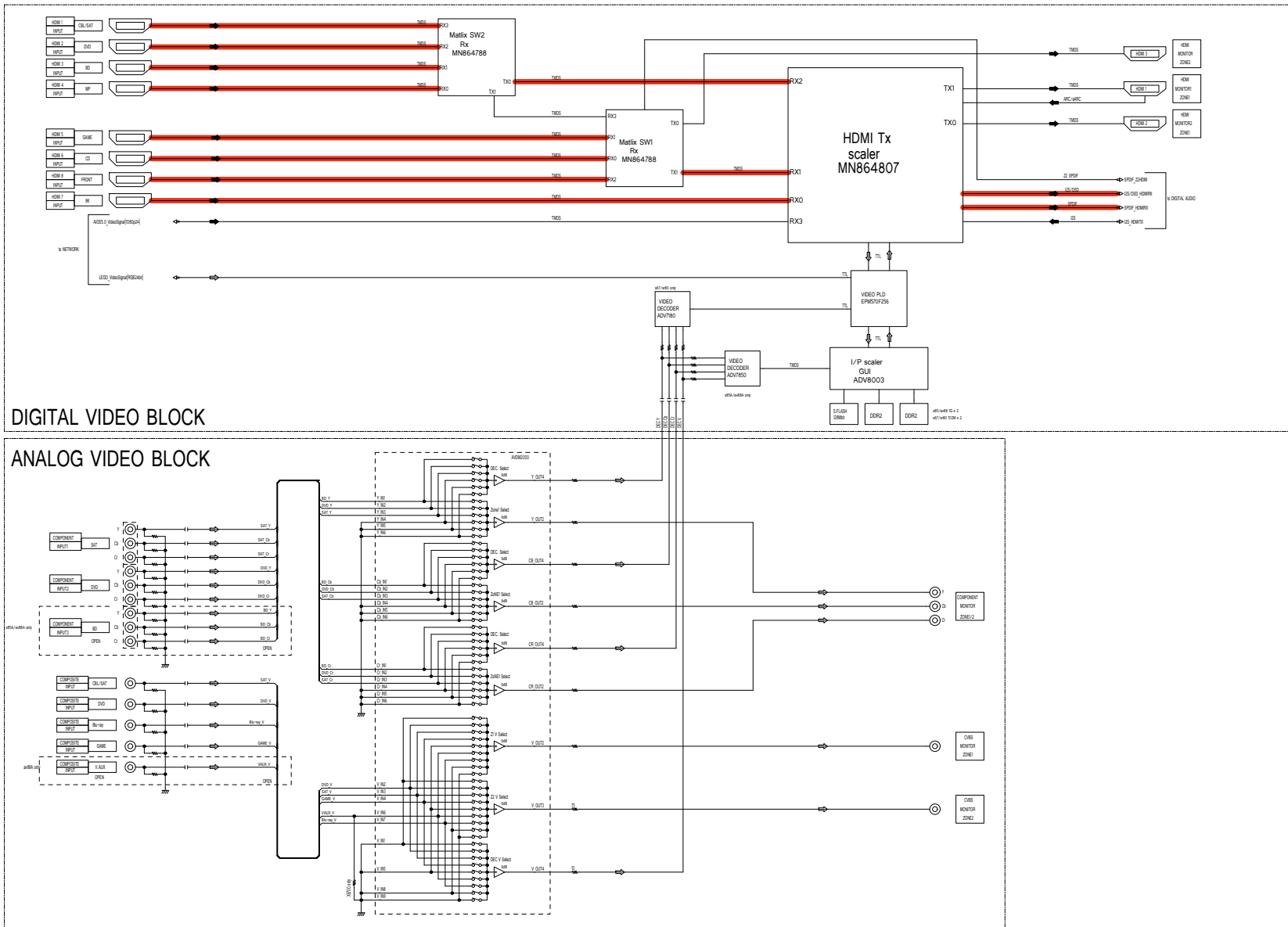

fig.V05c



Before Servicing
This Unit

Electrical

Mechanical

Repair Information

Updating

fig.V06a

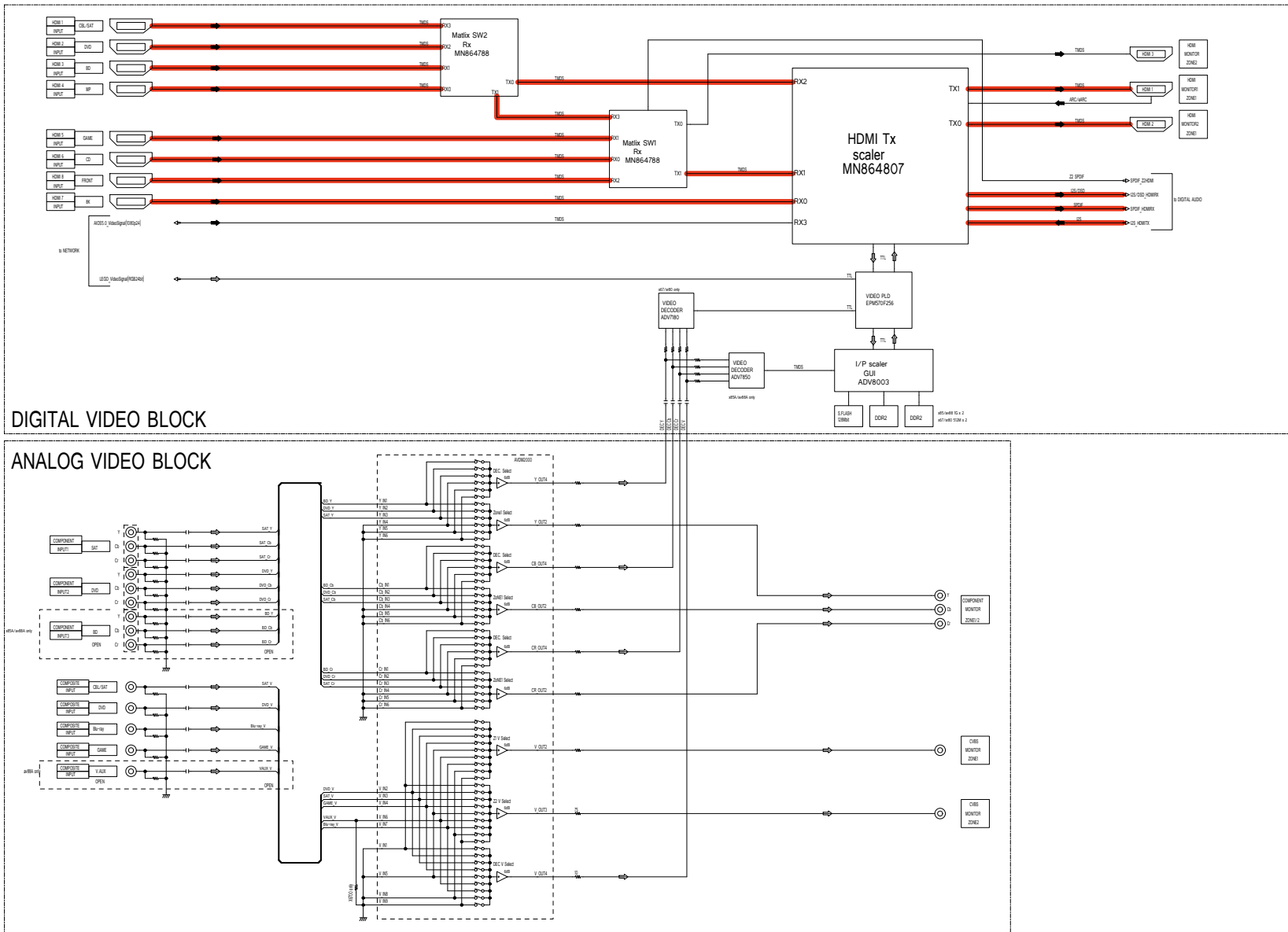

fig.V06b

AVR-X6700/SR8015 DIGITAL AUDIO/NETWORK BLOCK DIRAGRAM

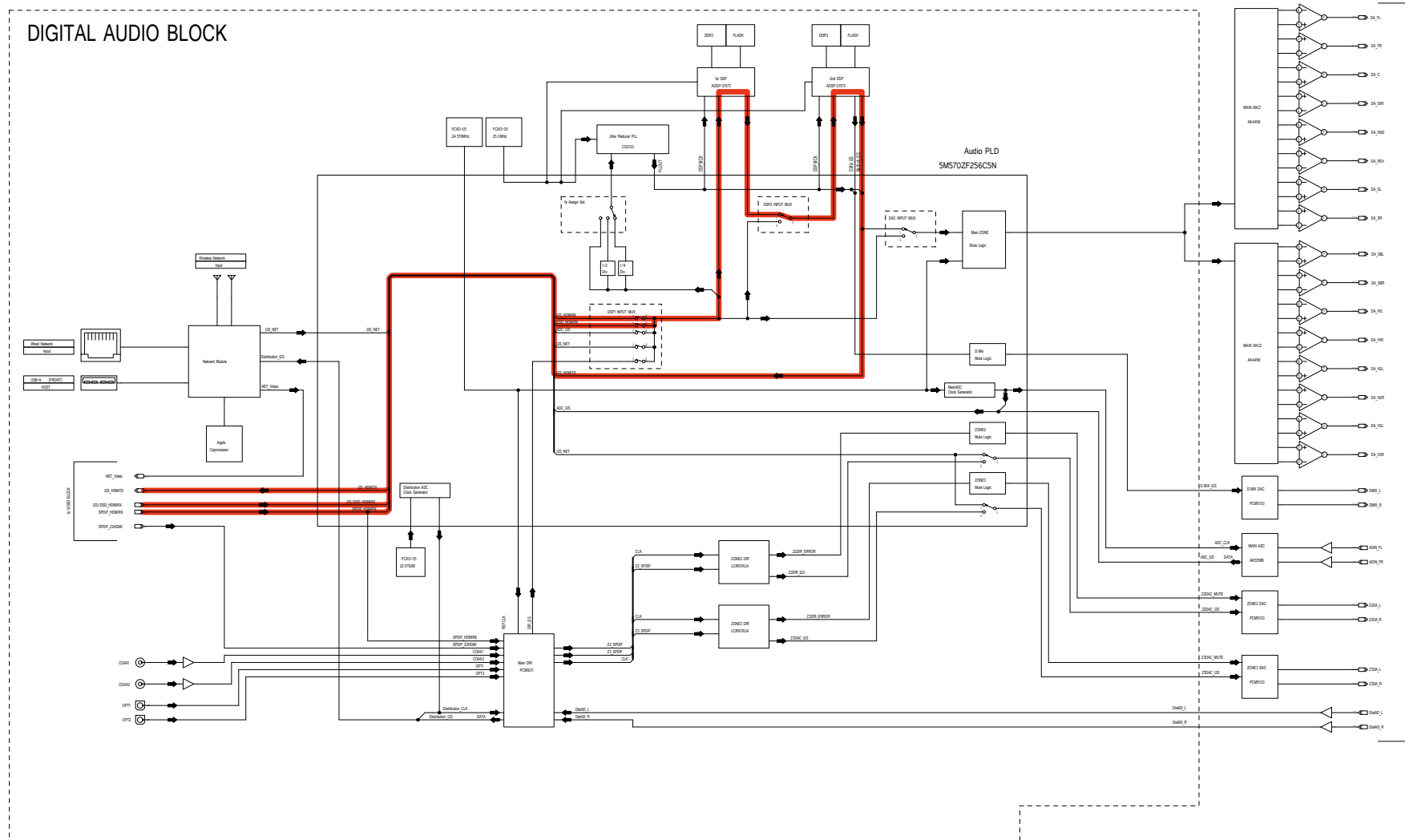
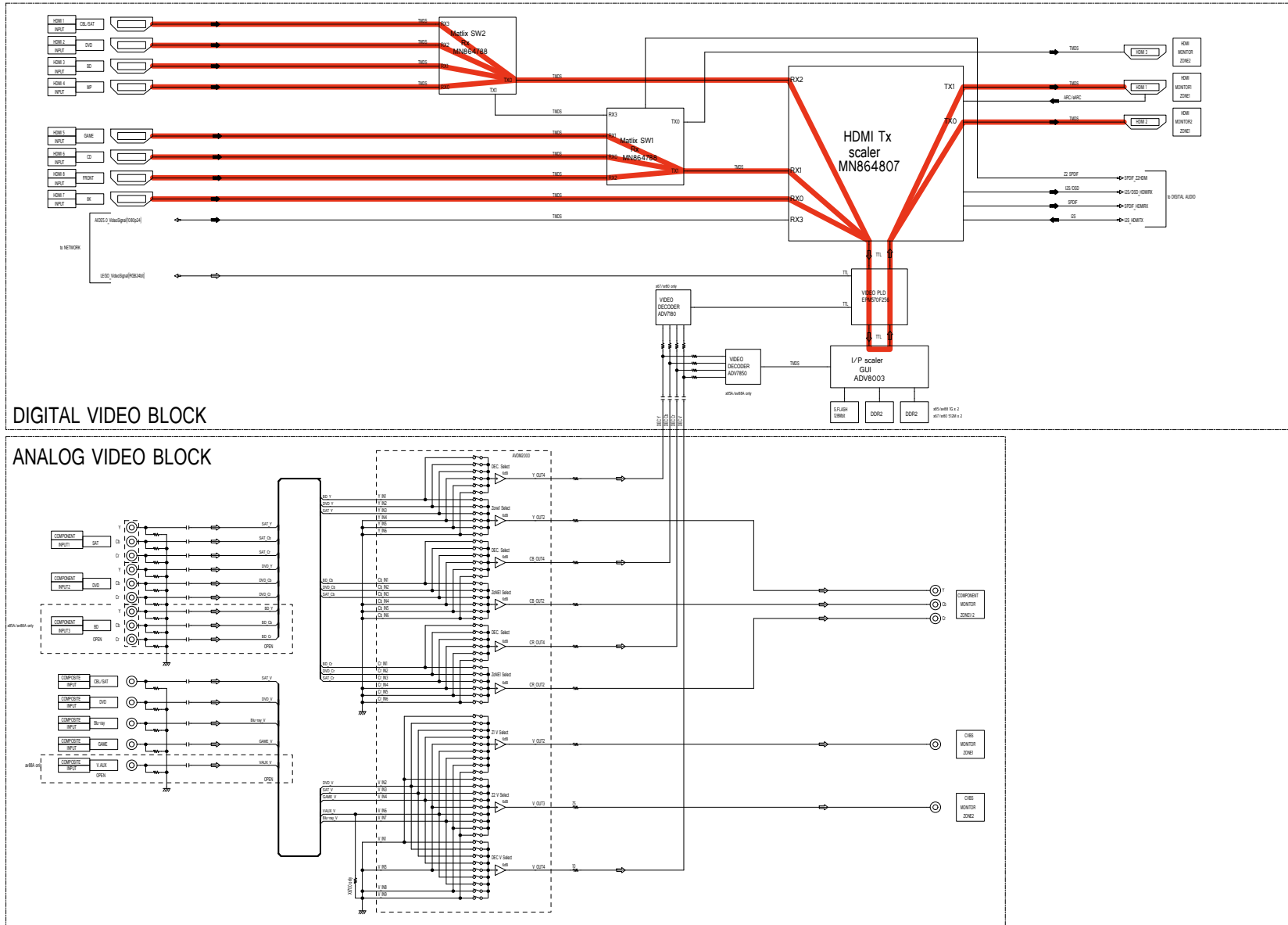

fig.V07



Before Servicing
This Unit

Electrical

Mechanical

Repair Information

Updating

JIG FOR SERVICING

Use the following jigs (extension cable kit) when repairing the PCBs.
Order with your dealer for the jigs your dealer if necessary.

CAUTION : Incorrect connections may cause malfunction.

Connection of Jig for DIGITAL PCB

---Items to Be Prepared---

- 8U-110084S : EXTENSION UNIT KIT : 1 Set
- Insulation sheet (Not supplied) : 1 sheet
- Ground lead (Not supplied) : 1 pc

-Proceeding-

(1) Remove the screws.



(2) Remove the connector PCB.



- (3) Remove the DIGITAL PCB from the chassis and turn it over.
Place an insulation sheet larger than the PCB underneath the DIGITAL PCB.
※ Connect the earth of the PCB to the chassis using an earth wire, etc.

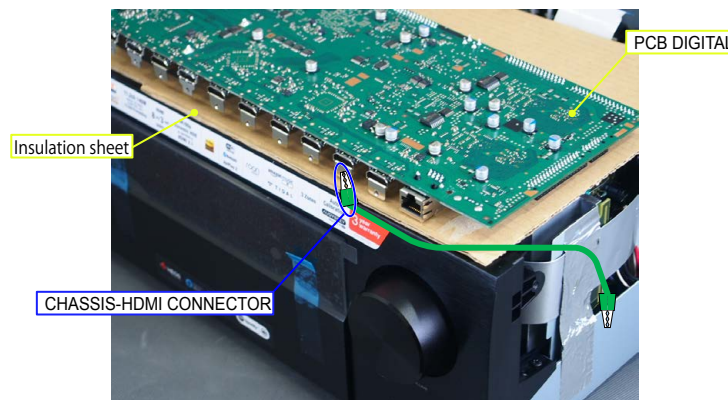

(4) Connect the expansion cables.

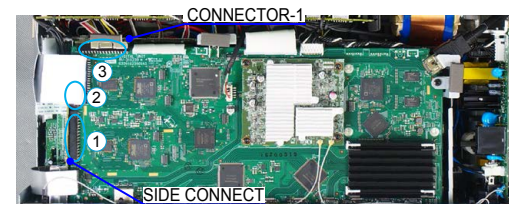

Board-to-Board Connections

No.	Pin	Ref. No.	PCB		Ref. No.	PCB
①	33pin	N902	SIDE CONNECT	↔	N6014	DIGITAL
②	11pin	N901	SIDE CONNECT	↔	N9030	DIGITAL
③	33pin	N951	CONNECT-1	↔	N6012	DIGITAL

Adjusting Idling Current

NOTE : Adjusting the idling current when "ECO Mode" is set may damage the Power AMP.

1. Preparation

- (1) Prepare a DC voltmeter.
- (2) Place the unit under normal usage conditions, away from highly ventilated areas such as next to an air conditioning machine or electric fan.
The set requires an ambient temperature of 15°C to 30°C and standard humidity.
- (3) Settings of This Unit
 - POWER (Power source switch) STANDBY
 - SPEAKER (Speaker terminal) No load
 (Do not connect equipment such as speakers or dummy resistors.)

2. Adjustment Procedure

- (1) Make sure that "ECO Mode" is off.
 - Press the "SETUP" button on the remote control to display the GUI menu.
 - Press the cursor button to select "General" → "ECO" → "Mode" → "Off".
- (2) Remove the top cover and turn "V101/V201" (ALL Channel) of the AMP PCB counterclockwise(↺) as far as possible.
- (3) Connect the DC Voltmeter to the test points.

FRONT Lch	: N5820 3, 4pin	: V101
FRONT Rch	: N5844 2, 3pin	: V201
CENTER ch	: N5820 5, 6pin	: V101
SURROUND Lch	: N5820 1, 2pin	: V101
SURROUND Rch	: N5844 4, 5pin	: V201
SURROUND-BACK Lch	: N5843 6, 7pin	: V101
SURROUND-BACK Rch	: N5823 1, 2pin	: V201
HEIGHT1 Lch	: N5843 4, 5pin	: V101
HEIGHT1 Rch	: N5823 3, 4pin	: V201
HEIGHT2 Lch	: N5843 2, 3pin	: V101
HEIGHT2 Rch	: N5823 5, 6pin	: V201
- (4) Connect the power cord to an outlet. Next, press the power button to turn on the power.
- (5) Set this unit as follows.
 - MASTER VOLUME : "----" (↺ min.) : turn counterclockwise to the lowest position.
 - SPEAKER (Speaker terminal) No load
 (Do not connect equipment such as speakers or dummy resistors.)
 - MODE : Multi Ch Stereo
 - FUNCTION : TUNER
- (6) Turn "V101/V201" clockwise (↻) and adjust the voltage of the test point to "**8.0mV ± 0.5mV DC**" within 2 minutes.
- (7) 10 minutes after the preliminary adjustment, turn V101/V201 and set the voltage to "**8.0mV ± 2.0mV DC**".
- (8) Adjust the variable resistance of each channel using the same method.

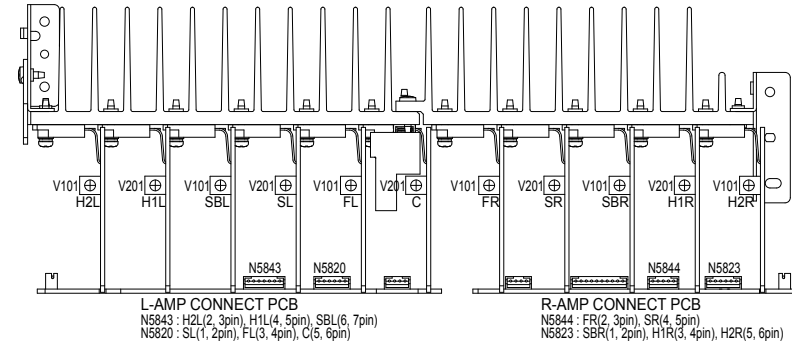
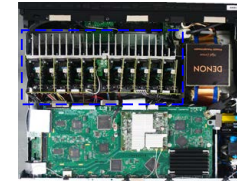

PROCEDURE AFTER REPLACING THE PCB.

PROCEDURE AFTER REPLACING THE U-COM, ETC.

FIRMWARE UPDATE PROCEDURE

1. Items necessary for update
2. Update preparation with a USB flash drive
3. Update method when the DIGITAL PCB or network module is replaced (Using a USB flash drive)
4. Update Method for Service Region Settings
5. Normal Firmware Update Method from USB Flash Drive
6. Normal Firmware Update Method from OTA
7. About the error codes

PROCEDURE AFTER REPLACING THE PCB.

The procedure after replacing the printed circuit boards is as follows.

(1) Change the resistor for setting the region.

Model Area	DIGITAL PCB		
	R6217	R6218	R6219
North America (E3)	OPEN	0	OPEN
Europe (E2)	0	OPEN	OPEN
China (E1C)	OPEN	OPEN	OPEN
Japan (JP)	OPEN	OPEN	0

See the PCB below.

(2) Be sure to replace the software with the latest version.

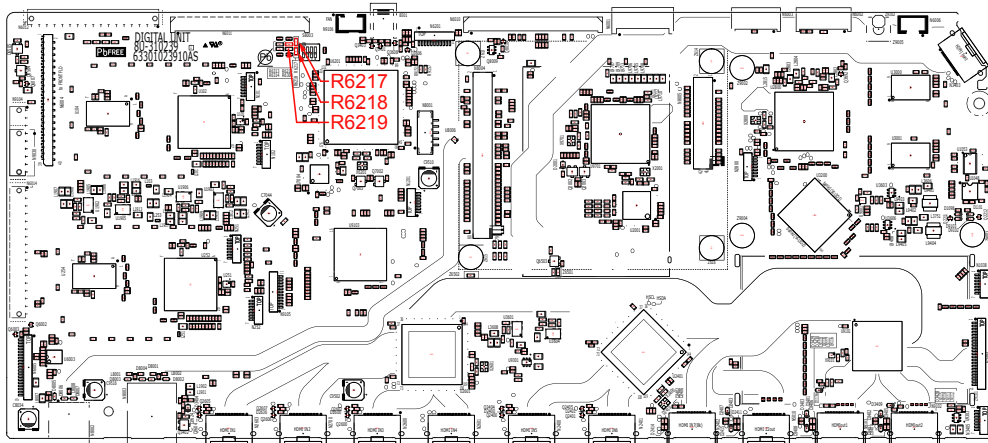

PROCEDURE AFTER REPLACING THE U-COM, ETC.

The procedure after replacing the MCU (microprocessor), flash ROM, etc. is as follows.

Implement the update method when the DIGITAL PCB or network module is replaced.

PCB Name	Ref. No.	Description	Procedure after Replacement	Remark
DIGITAL	U6201	R5F564MJCDFC	B	SOFTWARE : Main
DIGITAL	U103 U253	MX25L12835FMI-10G	B	SOFTWARE : DSP1/2 ROM
DIGITAL	U2801	MX25L12835FMI-10G	B	SOFTWARE : GUI ROM
DIGITAL	U9103	5M570ZF256C5N	C	SOFTWARE : VIDEO PLD
DIGITAL	U3200	EPM570F256C4N	C	SOFTWARE : AUDIO PLD
MODULE	B05	NETWORK MODULE	D	SOFTWARE : Network

Procedure after Replacement

A : The software has been written. The software is not written at the time of replacement.

B : The software has been written. The software may need to be rewritten by version updates. Check the version.

C : The software has not been written. The software needs to be written after replacement.

See "[FIRMWARE UPDATE PROCEDURE](#)" for information on writing the software.

D : The software has been written. Be sure to rewrite with the latest software for your service region.

See "[3. Update method when the DIGITAL PCB or network module is replaced \(Using a USB flash drive\)](#)" for information on rewriting the software.

FIRMWARE UPDATE PROCEDURE

1. Items necessary for update

Items necessary for update are as follows.

Update Type	Needed Part for Update	Requirement	Offered / not Offered		
			Standard Service Equipment Not offered by D&M	Purchase from D&M Article code	Download from SDI
Via USB	USB flash drive (USB 2.0 : Min 1GB) • We recommend a USB memory device that has an LED installed.	Formatting FAT16 or FAT 32	X	-	"Table 1" or "Table 2"
Via OTA	Internet Connection by Broadband Circuit	-	X	-	-
	Modem	-	X	-	-
	Router	-	X	-	-
	Ethernet cable (CAT-5 or greater is recommended)	-	X	-	-

Table 1

Update download file when the DIGITAL PCB or network module is replaced

Model Name	Model Area	Download from SDI
AVR-X6700H AVC-X6700H	ALL	avr_40.prod.update.factory.xxxx.zip

Table 2

Update download file when the firmware is updated (Two files, "HW component" and "LEGO component")

Model Name	Model Area	Download from SDI	
		For HW component	For LEGO component
AVR-X6700H E3	North America (E3)	Product ID : 000101230100	DPMS_AVC-X6700H_LEGO_xxxx.zip heos_40.prod_x.xxx.xx.zip
AVC-X6700H E2	Europe (E2)	Product ID : 000101230200	
AVC-X6700H E1C	China (E1C)	Product ID : 000101230500	
AVC-X6700H JP	Japan (JP)	Product ID : 000101230400	

Before Servicing
This Unit

Electrical

Mechanical

Repair Information

Updating

2. Update preparation with a USB flash drive

You can update the firmware by downloading the latest version with USB flash drive.

2.1. Connecting to the USB flash drive

(1) Preparation

- Windows PC
- USB flash drive format : Prepare a USB flash drive formatted in FAT16 or FAT32.
※We recommend a USB flash drive that has an LED installed.

NOTE :

- Use a memory that supports USB2.0.
- Do not run the USB flash drive through a hub.
- Do not connect a computer to the USB port of this unit using a USB cable.
- Do not use an extension cable when connecting the USB flash drive.
- Save the update file on a blank USB flash drive for use.
- If a USB flash drive cannot be updated, replace it with a different USB flash drive and perform the update again.

2.2. Unzipping the Downloaded File

Unzip the downloaded file on your computer.

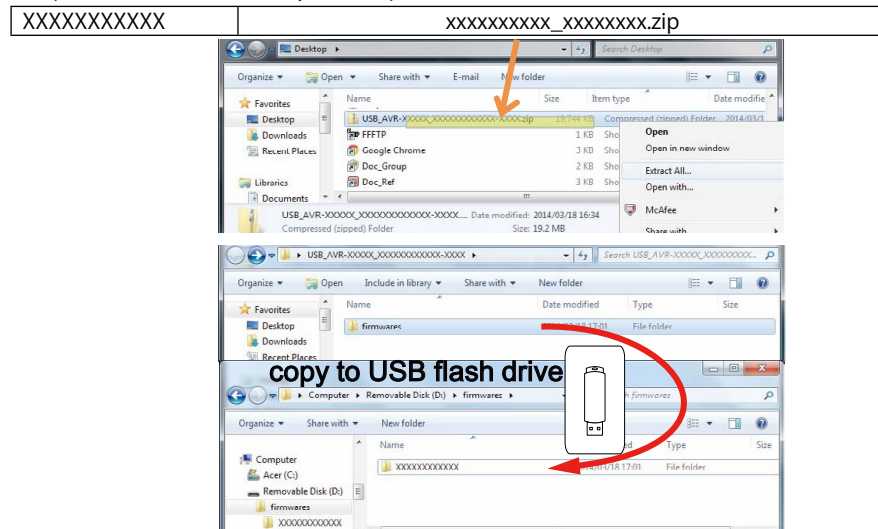

There are folders or files after unzipping.

Copy these folders or files onto the USB flash drive.

The folders or files must be placed in the root directory of the USB flash drive.

3. Update method when the DIGITAL PCB or network module is replaced (Using a USB flash drive)

3.1. File structure on USB flash drive

DIGITAL PCB or network module is replaced onto the USB flash drive in the following structure.

After unzipping the files, store them in the root of the same USB flash drive.

Model Area	Download from SDI
ALL	avr_40.prod.update.factory.xxxx.zip

USB flash drive root

- + avr_40.prod.update.factory
- + xxxxxx.ota-download
- + heos_40.prod.update.factory

xxxxxx : Model name
zz : Region

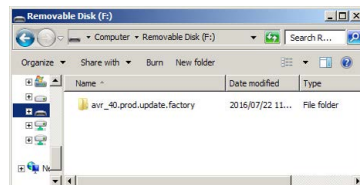

3.2. Start the update.

NOTE :

- Remove the LAN cable from this unit when updating. (Do not connect to a wired or wireless network.)
- The GUI menu setting details and image quality adjustment setting details are initialized when Firmware Factory Restore is performed. Therefore, take a note of the setting details beforehand and reconfigure the settings after update.
- Do not remove the USB flash drive until updating is completed.
- Do not turn off the power until updating is completed.
- It takes a maximum of approximately 25 minutes for update to complete.

Once an update is started, normal operations cannot be performed until it is completed.

- Press the power button to turn on the power.
- Wait for this unit to start up.
- Set the input source to HEOS Music.

Check that the display is as shown below.

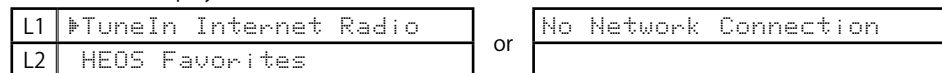

L1 : Content of the display is scrolled.

- Insert the USB flash drive into the USB port.

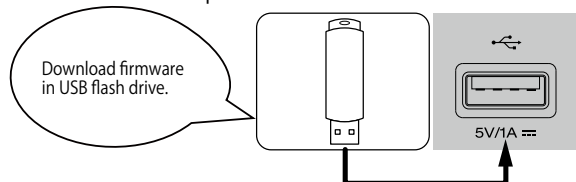

- USB Update starts automatically. The Standby LED lights red.

Display during USB update

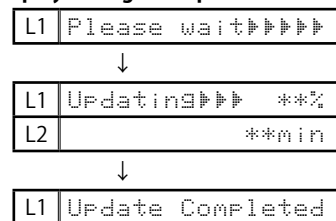

It takes a maximum of approximately 25 minutes for update to complete.

- The unit restarts when update is complete.
 - When update is complete, the folder name on the USB flash drive changes to "avr_40.prod.update.factory.done". To use the files again, delete the ".done" part.

- Execute Firmware Factory Restore. While holding down buttons "SETUP" and "DIMMER" simultaneously, press the power button to turn on the power.

Display during Firmware Factory Restore

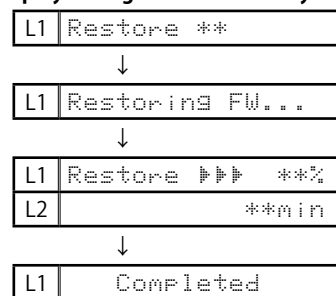

It takes approximately 15 minutes for Firmware Factory Restore to complete.

- Execute Service Region Settings. See "4. Update Method for Service Region Settings"
- Check that the version is the specified version. See "1. Version Display Mode"
- If necessary, use OTA or the USB flash drive to update the firmware to the newest version.
 - We recommend using the firmware update method using OTA. See "5. Normal Firmware Update Method from USB Flash Drive" or "6. Normal Firmware Update Method from OTA"

4. Update Method for Service Region Settings

Copy the Service Region Settings from the USB flash drive to this unit.

4.1. Creating a Service Region Settings file

(1) Click [Start button] - [Accessories] - [notepad] on the PC to launch the notepad.

(2) Enter "TEXT".

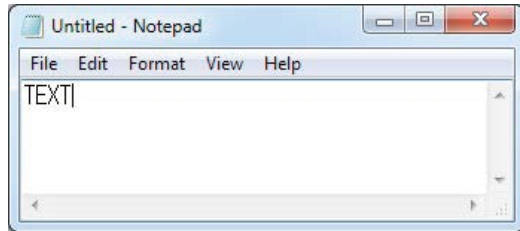

(3) Click "File", and then click "Save As...".

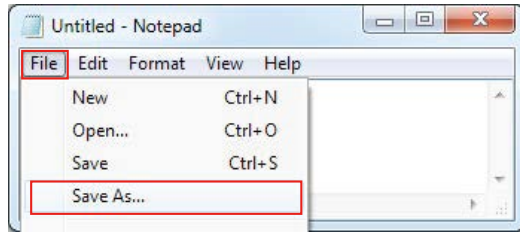

(4) Enter the file name and click the Save button.

NOTE : Enter the file name in double quotation marks. (The file extension is not required.)

Service Region	File name
North America	"denon-config-locale-set-1"
Europe	"denon-config-locale-set-2"
Japan	"denon-config-locale-set-3"
Australia	"denon-config-locale-set-4"
Korea	"denon-config-locale-set-5"
China	"denon-config-locale-set-6"
Israel	"denon-config-locale-set-7"

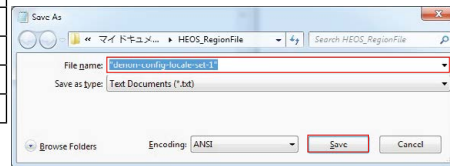

(5) Copy the files created on the USB flash drive.

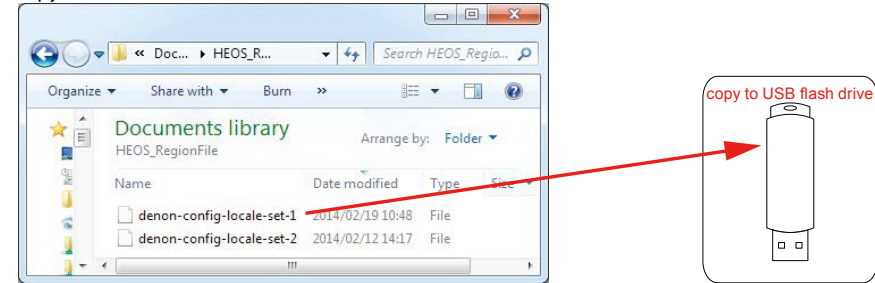

4.2. Starting Service Region Settings

NOTE :

- Remove the LAN cable from this unit when updating. (Do not connect to a wired or wireless network.)
- We recommend a USB memory device that has an LED installed.

(1) Press the power button to turn on the power.

(2) Wait for this unit to start up.

(3) Set the input source to HEOS Music.

Check that the display is as shown below.

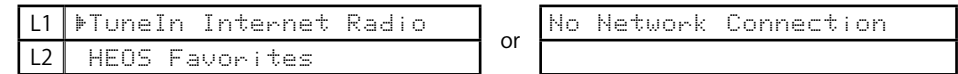

L1 : Content of the display is scrolled.

(4) Insert the USB flash drive into the USB port.

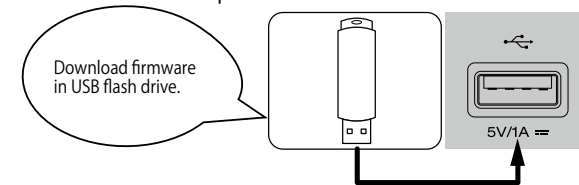

(5) Wait for at least 10 seconds before removing the USB flash drive.

(If the USB flash drive has an LED, this LED will be flashing. Remove the USB flash drive when the LED stops flashing.)

5. Normal Firmware Update Method from USB Flash Drive

5.1. File structure on USB flash drive

Copy the normal update files onto the USB flash drive in the following structure.

After unzipping the HW component USB update files for the target model and LEGO USB update files, store them in the root of the same USB flash drive.

Model Area	Download from SDI	
	For HW component	For LEGO component
North America (E3)	DPMS_AVR-X6700HALL_LEGO_xxxx.zip Product ID : 000101220100	heos_40.prod_x.xxx.xx.zip
Europe (E2)	DPMS_AVC-X6700HALL_LEGO_xxxx.zip Product ID : 000101220200	
China (E1C)	DPMS_AVC-X6700HALL_LEGO_xxxx.zip Product ID : 000101220500	
Japan (JP)	DPMS_AVC-X6700HALL_LEGO_xxxx.zip Product ID : 000101220400	

USB flash drive root

- + AVxxxxx_xxxx.update.auto
- + heos_40.prod.update.x-xxx-xx

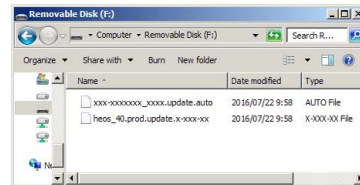

5.2. Start normal update

NOTE :

- Remove the LAN cable from this unit when updating.
(Do not connect to a wired or wireless network.)
 - Do not remove the USB flash drive until updating is completed.
 - Do not turn off the power until updating is completed.
 - It takes a maximum of approximately 25 minutes for update to complete.
- Once an update is started, normal operations cannot be performed until it is completed.
The GUI menu settings and image adjustment settings of this unit may be initialized.
Note down the settings before updating, and set them again after updating.

- (1) Press the power button to turn on the power.
- (2) Wait for this unit to start up.
- (3) Set the input source to HEOS Music.

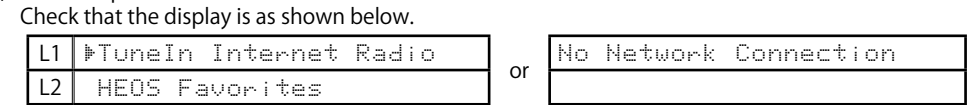

L1 : Content of the display is scrolled.

- (4) Insert the USB flash drive into the USB port.

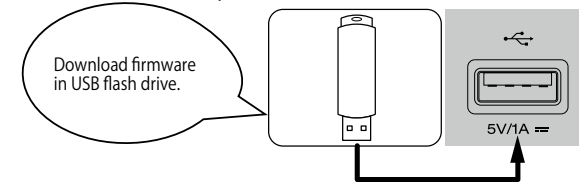

- (5) USB Update starts automatically.
The Standby LED lights red.

Display during USB update

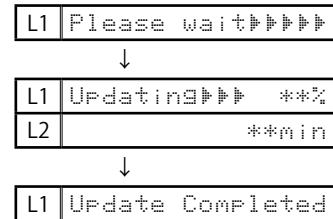

It takes a maximum of approximately 25 minutes for update to complete.

- (6) The unit restarts when update is complete.
- (7) After updating the firmware, check the version.
See "1. Version Display Mode"

6. Normal Firmware Update Method from OTA

Download the latest firmware from our website and update the firmware.

---Cautions on Firmware Update---

- For the update procedure, a proper broadband Internet connection environment and settings are required.
 - Do not turn off the power until updating is completed.
 - It takes a maximum of approximately 25 minutes for update to complete.
- Once an update is started, normal operations cannot be performed until it is completed. The GUI menu settings and image adjustment settings of this unit may be initialized. Note down the settings before updating, and set them again after updating.

6.1. Network Connection

- (1) System Requirements
 - Internet Connection by Broadband Circuit
 - Modem
 - Router
 - Ethernet cable (CAT-5 or greater is recommended)
- (2) Setting

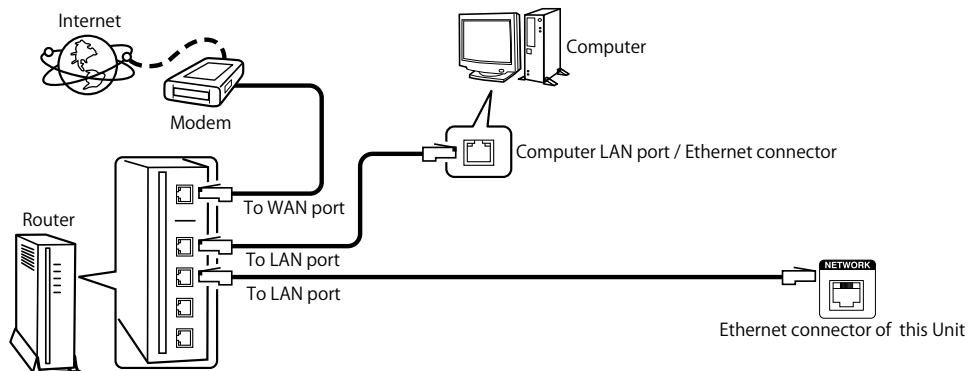

6.2. Check and update the firmware

Check if there is a firmware update available. It is also possible to check approximately how long the update will take.

- (1) Press the "SETUP" button on the remote control to display the GUI menu.
- (2) Press the cursor button to select "General" → "Firmware" → "Check for Update".
- (3) Check update
 - If the firmware version is anything other than the latest version, select "Update Now" to update the firmware.
 - "No update required. Latest version installed." is displayed when the firmware version is up to date.
- (4) OTA Update starts automatically. The Standby LED lights red.

Display during OTA update

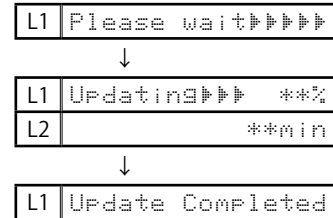

It takes a maximum of approximately 25 minutes for update to complete.

- (5) The unit restarts when update is complete.
- (6) After updating the firmware, check the version. See "1. Version Display Mode"

7. About the error codes

See the table below for details on error codes and solutions when updating the firmware. Error codes are displayed in 4 digits, YYXX (YY : DeviceID, XX : ErrorCode).

Display

L1	Updating▶▶▶▶ **%
L2	***min



L1	Update ErrorYYXX
L2	Please check you

L2 : Content of the display is scrolled.

Remedies

Error Code (YYXX) (DeviceID/ErrorCode)	Remedies
000A	"Connection failed. Please check your network, then try again."
0009	"Update failed. Please check your network, then try again."
0009	"Upgrade failed. Please check your network, then try again."
YY00 YY01 YY02 YY03 YY04 YY07	"Please check your network, unplug and reconnect the power cord, and try again."
YY00 YY01 YY02 YY03 YY04 YY07	"Please unplug and reconnect the power cord, and try again."
0005	"Incompatible update file found on the USB device. Please check the file."
0006	"Update file is corrupted. Please check the file."
000B	"Please contact customer service in your area." ※ Check the power supply and communication lines of each device.

Device ID table

Device ID (YY)	Device Name
00	General
01	Main CPU
0E	Main FBL (No used)
11	DSP1 or DSP
12	DSP2 ※ Except : AVR-X3700H/AVR-X2700H/AVR-S960H/NR1711/SR5015
13	DSP3 (No used)
19	DSP4 (No used)
15	Audio PLD
22	Video PLD ※ Except : AVR-X2700H/AVR-X2700H/AVR-S960H/NR1711
2A	GUI
2B	PIMG ※ ONLY : AVR-X2700H/AVR-S960H/NR1711/SR5015
33	LEGO

Error Code table

Type code (XX)	Description
00	Logical error
01	Error during erasing
02	Error during writing
03	Error during verifying
04	No access for the component
05	Package mismatched. Product ID, package version un-matched of the package manifest
06	Unpack dis-available of component package file
07	Time out
08	Latest firmware has already installed.
09	Error during download
0A	Error connection
0E	Hardware Error

---Checking the Firmware Version After the Update---

After updating the firmware, check the version.

See "1. Version Display Mode"

DENON®

www.denon.com