

INTEGRATED NETWORK AV RECEIVER

AVR-X1300W

AVR-S720W



- For purposes of improvement, specifications and design are subject to change without notice.
- Please use this service manual with referring to the operating instructions without fail.
- Some illustrations using in this service manual are slightly different from the actual set.

Click here!

On-line service parts list

We are getting ready.

On-line owner's manual

<http://manuals.denon.com/AVRX1300W/NA/EN/index.php>

<http://manuals.denon.com/AVRX1300W/EU/EN/index.php>

<http://manuals.denon.com/AVRX1300W/AP/ZH/index.php>

<http://manuals.denon.com/AVRS720W/NA/EN/index.php>

CAUTION IN SERVICING

ELECTRICAL

MECHANICAL

REPAIR INFORMATION

UPDATING

Please refer to the MODIFICATION NOTICE.

CAUTION IN SERVICING

SAFETY PRECAUTIONS

NOTE FOR SCHEMATIC DIAGRAM

NOTE FOR PARTS LIST

INSTRUCTIONS FOR HANDLING SEMICONDUCTORS AND OPTICAL UNIT

CAUTION IN SERVICING.

Initializing This Unit **AVR-X1300W**

JIG FOR SERVICING

Initializing This Unit **AVR-S720W**

JIG FOR SERVICING

SAFETY PRECAUTIONS

The following items should be checked for continued protection of the customer and the service technician.

leakage current check

Before returning the set to the customer, be sure to carry out either (1) a leakage current check or (2) a line to chassis resistance check. If the leakage current exceeds 0.5 milliamps, or if the resistance from chassis to either side of the power cord is less than 460 kohms, the set is defective.

Be sure to test for leakage current with the AC plug in both polarities, in addition, when the set's power is in each state (on, off and standby mode), if applicable.

⊙ **Make a safety check after servicing!**

Check that all screws, parts and wires removed or disconnected when servicing have been put back in their original positions, check that no serviced parts have deteriorate the area around. Then make an insulation check on the external metal connectors and between the blades of the power plug, and otherwise check that safety is ensured.

(Insulation check procedure)

Unplug the power cord from the power outlet, disconnect the antenna, plugs, etc., and on the power. Using a 500V insulation resistance tester, check that the insulation resistance value between the in plug and the externally exposed metal parts (antenna terminal, headphones terminal, input terminal, etc.) is 1M Ω or greater. If it is less, the set must be inspected and repaired.

CAUTION

Please heed the following cautions and instructions during servicing and inspection.

⊙ **Heed the cautions!**

Cautions which are delicate in particular for servicing are labeled on the cabinets, the parts and the chassis, etc. Be sure to heed these cautions and the cautions described in the handling instructions.

⊙ **Cautions concerning electric shock!**

- (1) An AC voltage is impressed on this set, so if you touch internal metal parts when the set is energized, you may get an electric shock. Avoid getting an electric shock, by using an isolating transformer and wearing gloves when servicing while the set is energized, or by unplugging the power cord when replacing parts, for example.
- (2) There are high voltage parts inside. Handle with extra care when the set is energized.

⊙ **Caution concerning disassembly and assembly!**

Through great care is taken when parts were manufactured from sheet metal, there may be burrs on the edges of parts. The burrs could cause injury if fingers are moved across them in some rare cases. Wear gloves to protect your hands.

⊙ **Use only designated parts!**

The set's parts have specific safety properties (fire resistance, voltage resistance, etc.). Be sure to use parts which have the same properties for replacement. The burrs have the same properties. In particular, for the important safety parts that are indicated by the \triangle mark on schematic diagrams and parts lists, be sure to use the designated parts.

⊙ **Be sure to mount parts and arrange the wires as they were originally placed!**

For safety reasons, some parts use tapes, tubes or other insulating materials, and some parts are mounted away from the surface of printed circuit boards. Care is also taken with the positions of the wires by arranging them and using clamps to keep them away from heating and high voltage parts, so be sure to set everything back as it was originally placed.

CAUTION

Concerning important safety parts

Many of the electric and the structural parts used in the set have special safety properties. In most cases these properties are difficult to distinguish by sight, and the use of replacement parts with higher ratings (rated power and withstand voltage) does not necessarily guarantee that safety performance will be preserved. Parts with safety properties are indicated as shown below on the wiring diagrams and the parts list in this service manual. Be sure to replace them with the parts which have the designated part number.

- (1) Schematic diagrams Indicated by the \triangle mark.
- (2) Parts lists Indicated by the \triangle mark.

The use of parts other than the designated parts could cause electric shocks, fires or other dangerous situations.

NOTE FOR SCHEMATIC DIAGRAM

WARNING:

Parts indicated by the \triangle mark have critical characteristics. Use ONLY replacement parts recommended by the manufacturer.

CAUTION:

Before returning the set to the customer, be sure to carry out either (1) a leakage current check or (2) a line to chassis resistance check. If the leakage current exceeds 0.5 milliamps, or if the resistance from chassis to either side of the power cord is less than 460 kohms, the set is defective.

WARNING:

DO NOT return the set to the customer unless the problem is identified and remedied.

NOTICE:

ALL RESISTANCE VALUES IN OHM. k=1,000 OHM / M=1,000,000 OHM

ALL CAPACITANCE VALUES ARE EXPRESSED IN MICRO FARAD, UNLESS OTHERWISE INDICATED. P INDICATES MICRO-MICRO FARAD. N INDICATES NANO FARAD. EACH VOLTAGE AND CURRENT ARE MEASURED AT NO SIGNAL INPUT CONDITION. CIRCUIT AND PARTS ARE SUBJECT TO CHANGE WITHOUT PRIOR NOTICE.

NOTE FOR PARTS LIST

1. Parts indicated by "nsp" on this table cannot be supplied.
2. When ordering a part, make a clear distinction between "1" and "1" (i) to avoid mis-supplying.
3. A part ordered without specifying its part number can not be supplied.
4. Part indicated by "@" mark is not illustrated in the exploded view.

WARNING: Parts indicated by the \triangle mark have critical characteristics. Use ONLY replacement parts recommended by the manufacturer.

INSTRUCTIONS FOR HANDLING SEMICONDUCTORS AND OPTICAL UNIT

Electrostatic breakdown of the semi-conductors or optical pickup may occur due to a potential difference caused by electrostatic charge during unpacking or repair work.

1. Ground for Human Body

Be sure to wear a grounding band (1 M ohm) that is properly grounded to remove any static electricity that may be charged on the body.

2. Ground for Workbench

Be sure to place a conductive sheet or copper plate with proper grounding (1 M ohm) on the workbench or other surface, where the semi-conductors are to be placed. Because the static electricity charge on clothing will not escape through the body grounding band, be careful to avoid contacting semi-conductors with your clothing

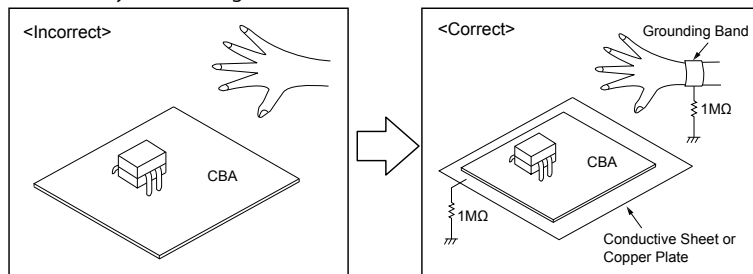

CAUTION IN SERVICING.

Initializing This Unit **AVR-X1300W**

Make sure to initialize this unit after replacing the microcomputer or any peripheral equipment, or the digital PCB.

1. Press the power button to turn off the power.
2. While holding down buttons "**ZONE2 SOURCE**" and "**DIMMER**" simultaneously, press the power button to turn on the power.
3. Release the buttons after confirming that the display flashes at 1-second intervals.
 - * The unit is initialized.

NOTE :

- If the unit fails to enter the service mode in step 3, repeat the procedure from step 1.
- Initializing the device restores the customized settings to the factory settings. Write down your settings in advance and reconfigure the settings after initialization.

AVR-X1300W

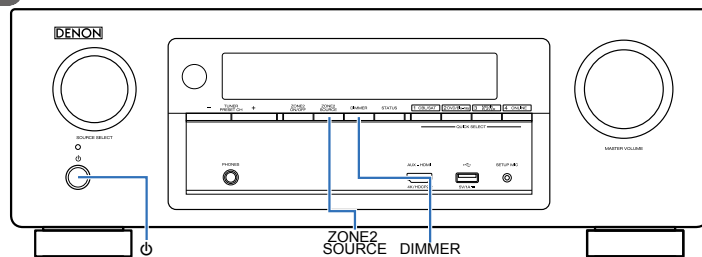

JIG FOR SERVICING

Use the following jigs (extension cable kit) when repairing the PCBs.
Order with your dealer for the jigs your dealer if necessary.

8U-110084S : EXTENSION UNIT KIT : 1 Set
(See [JIG FOR SERVICING](#))

Initializing This Unit **AVR-S720W**

Make sure to initialize this unit after replacing the microcomputer or any peripheral equipment, or the digital PCB.

1. Press the power button to turn off the power.
2. While holding down buttons "**TUNER PRESET CH +**" and "**TUNE -**" simultaneously, press the power button to turn on the power.
3. Release the buttons after confirming that the display flashes at 1-second intervals.
 - * The unit is initialized.

NOTE :

- If the unit fails to enter the service mode in step 3, repeat the procedure from step 1.
- Initializing the device restores the customized settings to the factory settings. Write down your settings in advance and reconfigure the settings after initialization.

AVR-S720W

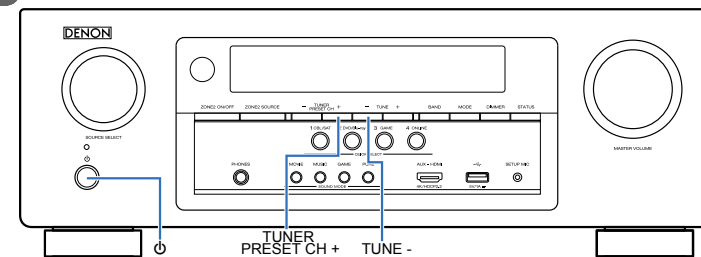

JIG FOR SERVICING

Use the following jigs (extension cable kit) when repairing the PCBs.
Order with your dealer for the jigs your dealer if necessary.

8U-110084S : EXTENSION UNIT KIT : 1 Set
(See [JIG FOR SERVICING](#))

ELECTRICAL

SCHEMATIC DIAGRAMS

SCH01_HDMI_RX
SCH02_HDMI_TX
SCH03_OSD
SCH04_DIGITAL_SUPPLY
SCH05_MCU
SCH06_MCU_LEVEL_CHG
SCH07_DIR_SRC
SCH08_DSP
SCH09_MAIN_DAC
SCH10_NETWORK
SCH11_ANALOG
SCH12_MAIN
SCH13_FRONT_HDMI
SCH14_DIFF-AMP
SCH15_FRONT
SCH16_REGULATOR
SCH17_SMPS

PRINTED CIRCUIT BOARDS

DIGITAL, F HDMI, TUNER, HEADPHONE, HDMI_FFC_CABLE
DIFF-AMP, BIAS-TR, PHONE WIRE GUIDE, TEMP_DETECT, FRONT_CABLE_GUIDE,
BT_WIRE_GUIDE, HDMI_CABLE_GUIDE, REGULATOR
MAIN
FRONT, IPODUSB_MIC, ENCODER&POWER, SMPS

LEVEL DIAGRAM

FRONT_ch
CENTER_ch
SUBWOOFER_ch
SURROUND_ch
SURR.BACK_ch
ZONE2

BLOCK DIAGRAM

ANALOG_AUDIO_DIAGRAM
DIGITAL_AUDIO_DIAGRAM
VIDEO_DIAGRAM

POWER DIAGRAM

WIRING DIAGRAM

SEMICONDUCTORS

1.IC's
2.FL_DISPLAY

HDMI_RX PART

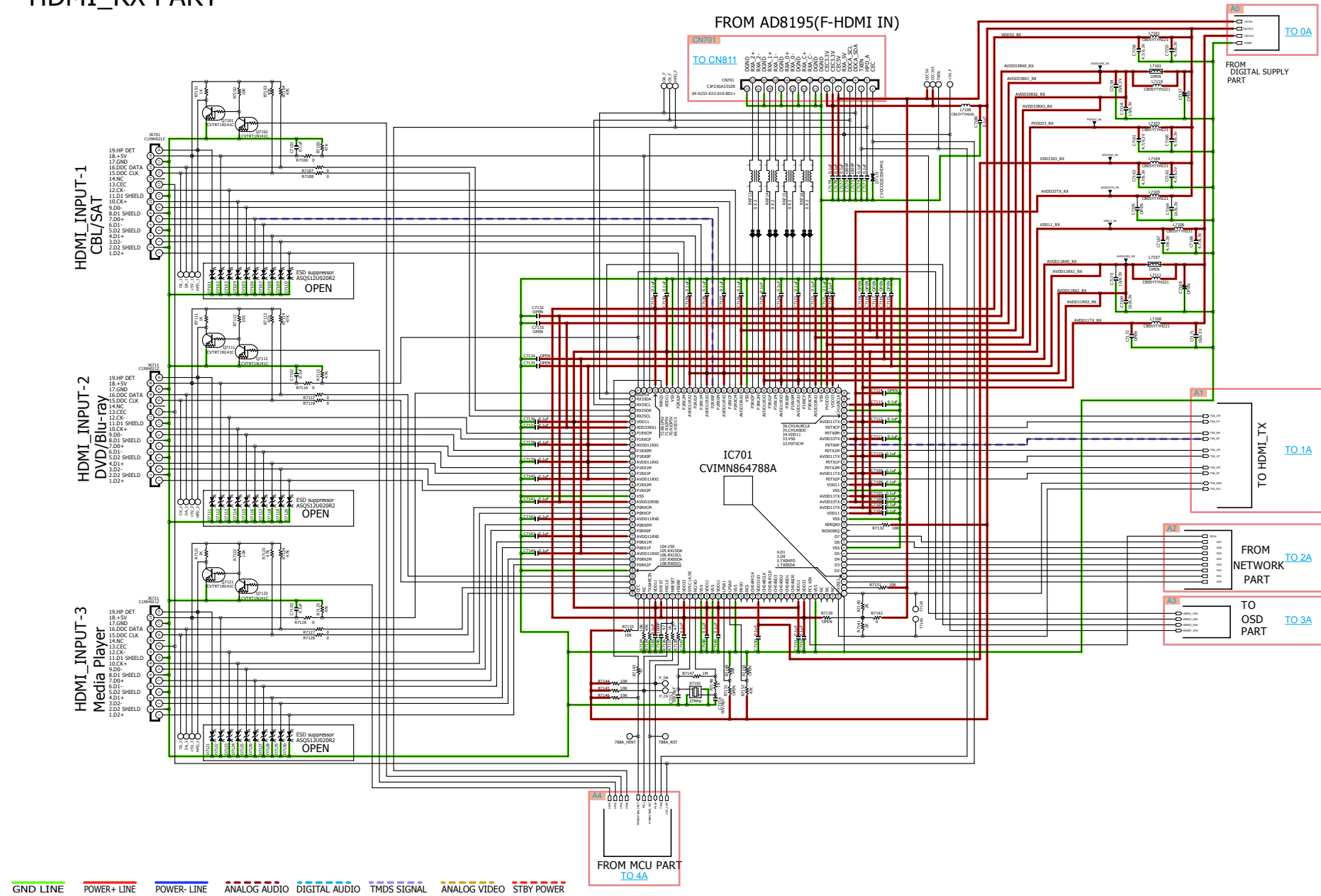

GND LINE POWER+ LINE POWER- LINE ANALOG AUDIO DIGITAL AUDIO TMDS SIGNAL ANALOG VIDEO STBY POWER

Caution in servicing Electrical Mechanical Repair Information Updating

HDMI_TX PART

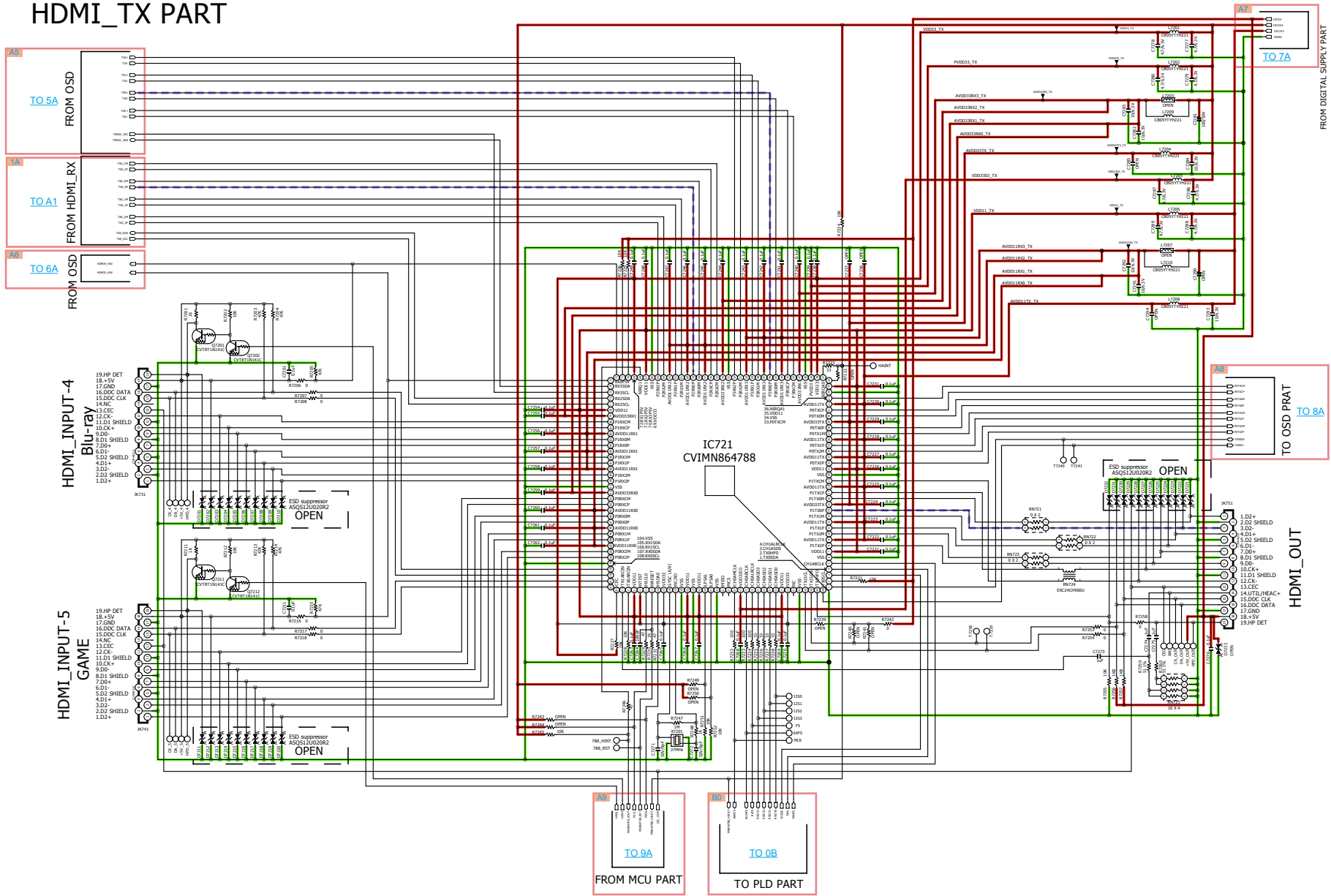

GND LINE POWER+ LINE POWER- LINE ANALOG AUDIO DIGITAL AUDIO TMDS SIGNAL ANALOG VIDEO STBY POWER

Caution in servicing

Electrical

Mechanical

Repair Information

Updating

OSD PART

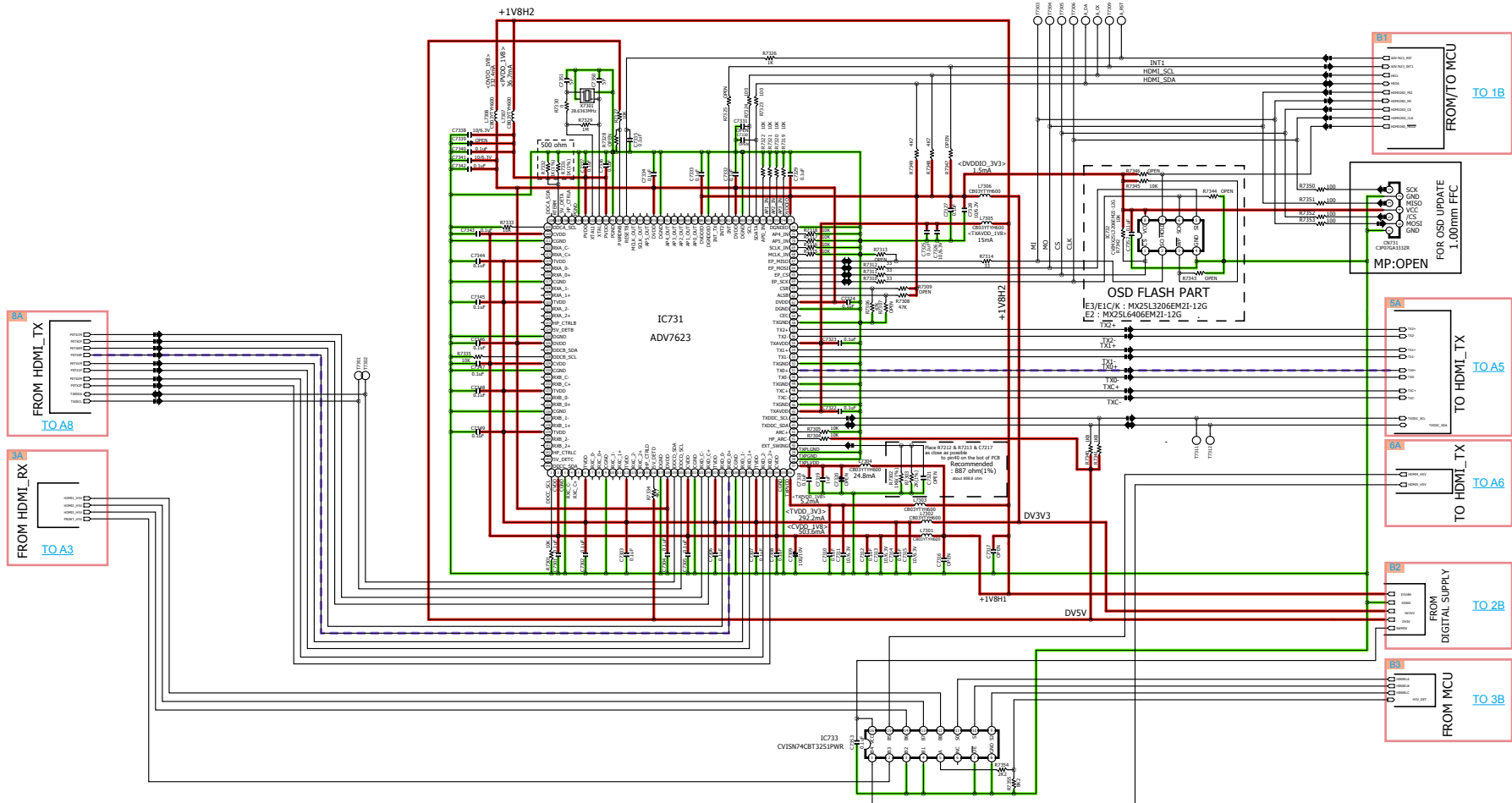

GND LINE POWER+ LINE POWER- LINE ANALOG AUDIO DIGITAL AUDIO TMDS SIGNAL ANALOG VIDEO STBY POWER

DIGITAL SUPPLY PART

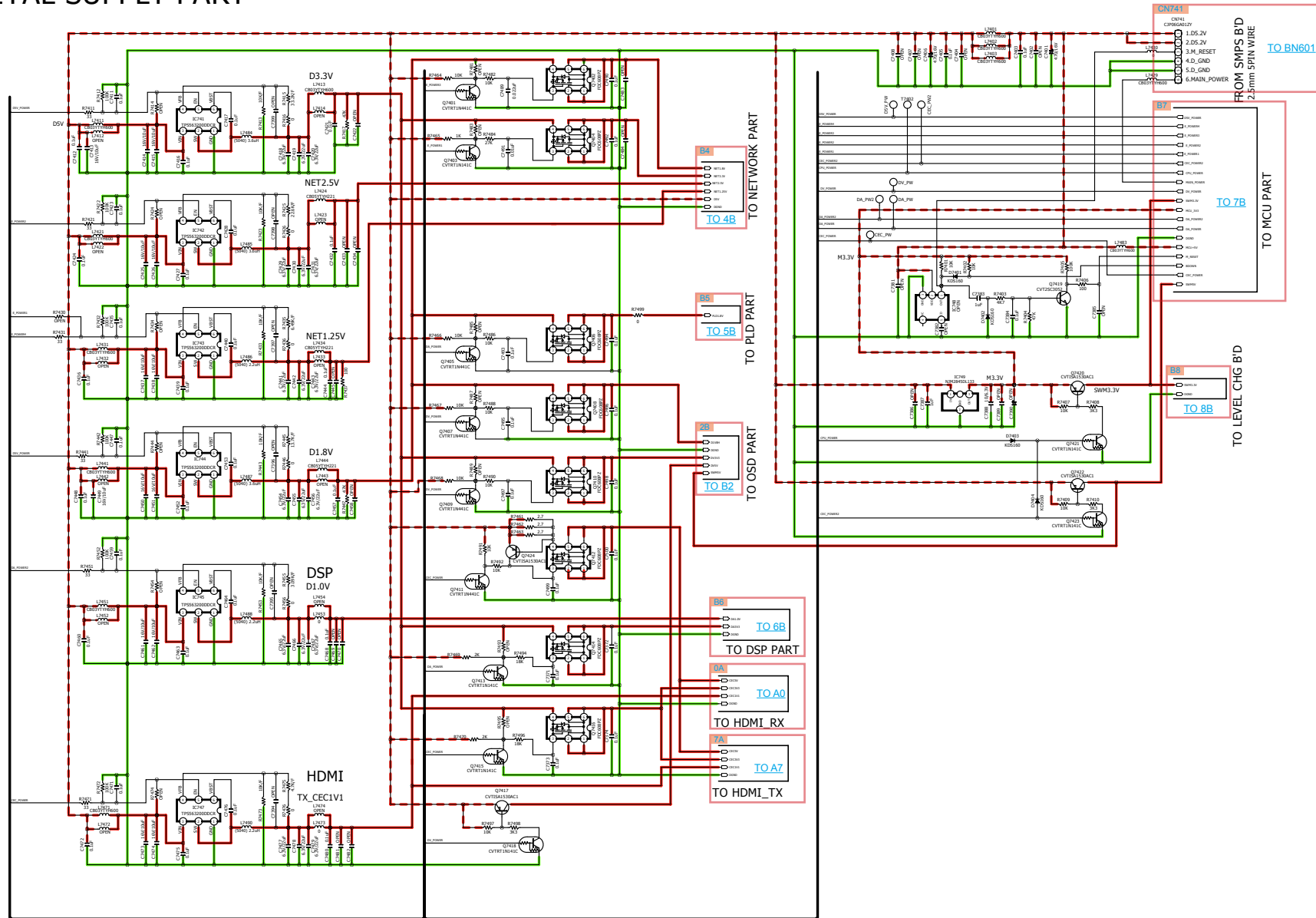

GND LINE POWER+ LINE POWER- LINE ANALOG AUDIO DIGITAL AUDIO TMDS SIGNAL ANALOG VIDEO STBY POWER

Caution in servicing

Electrical

Mechanical

Repair Information

Updating

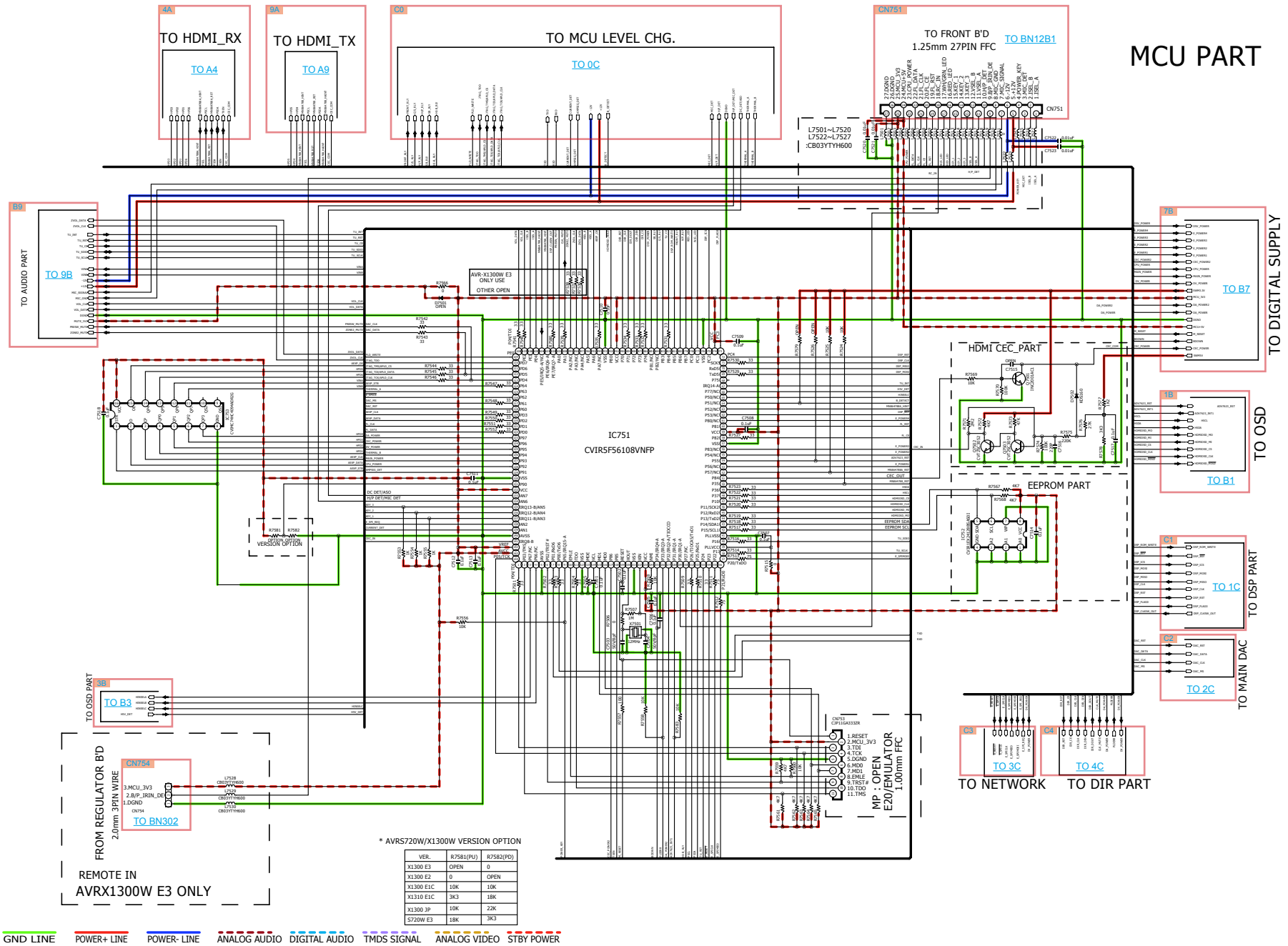

Caution in servicing

Electrical

Mechanical

Repair Information

Updating

DIR/PLD PART

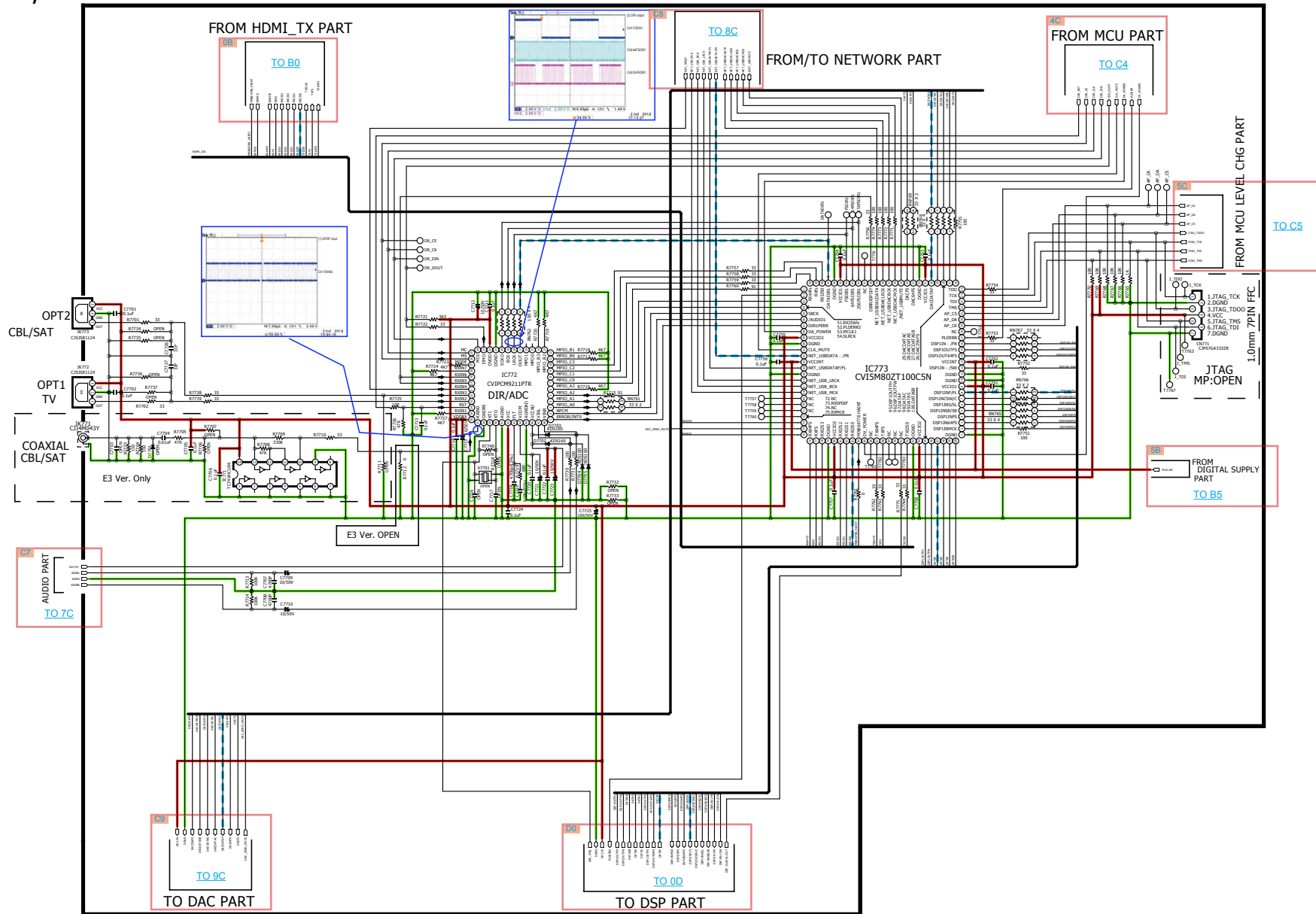

GND LINE POWER+ LINE POWER- LINE ANALOG AUDIO DIGITAL AUDIO TMDS SIGNAL ANALOG VIDEO STBY POWER

DSP PART

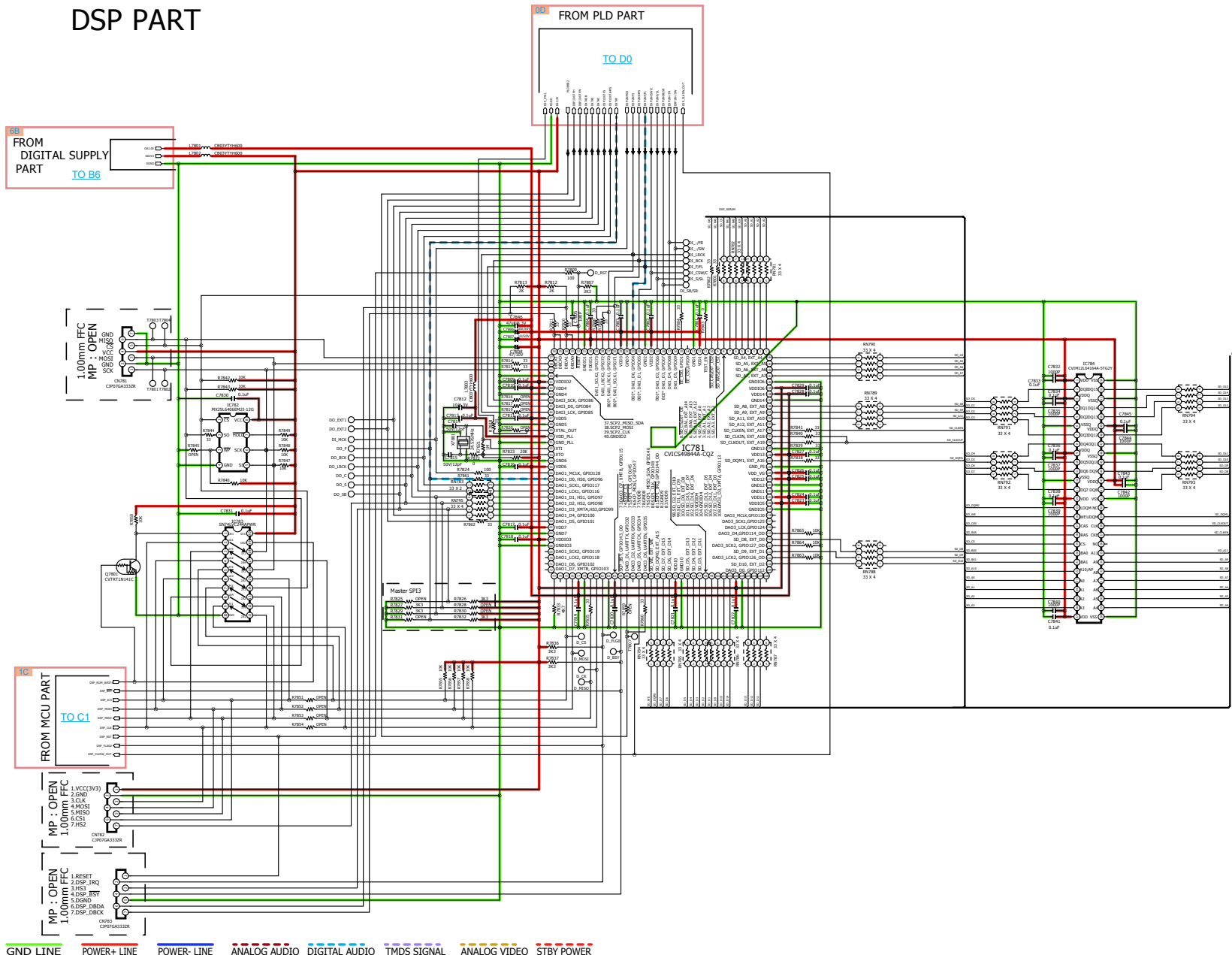

MAIN DAC PART

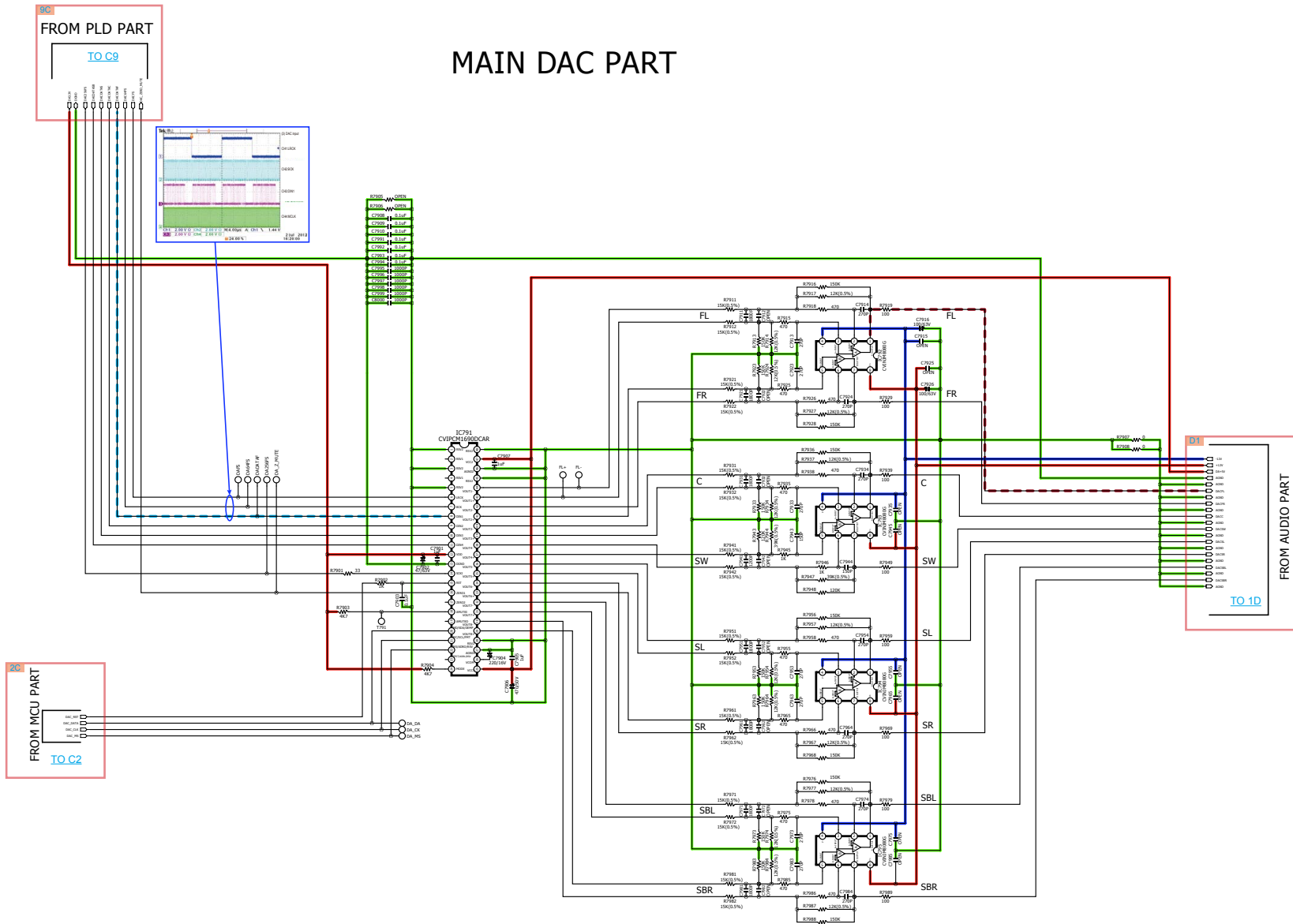

Caution in servicing

Electrical

Mechanical

Repair Information

Updating

NETWORK PART

NETWORK MODULE

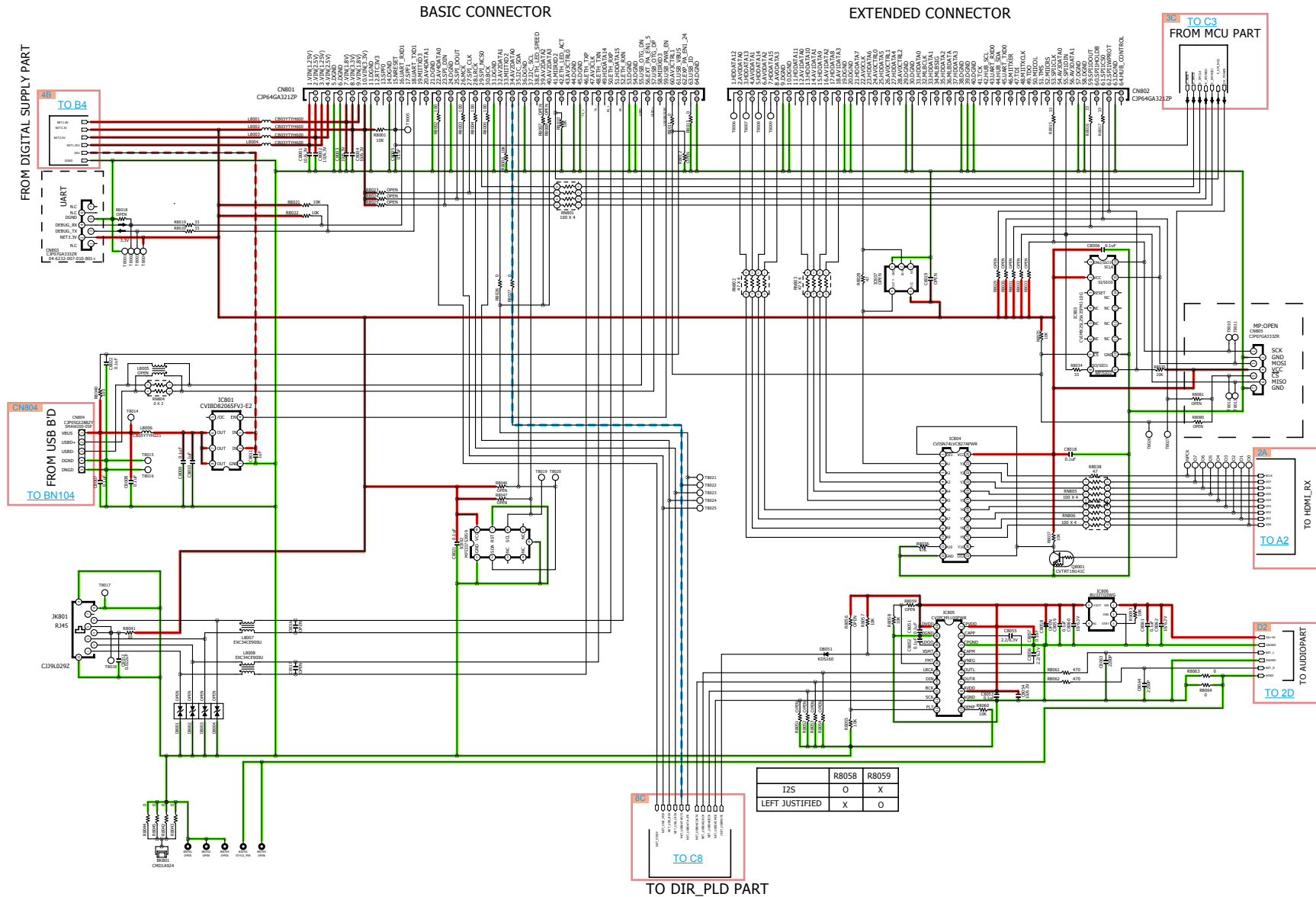

	R8058	R8059
I2S	O	X
LEFT JUSTIFIED	X	O

TO DIR_PLD PART

GND LINE POWER+ LINE POWER- LINE ANALOG AUDIO DIGITAL AUDIO TMSD SIGNAL ANALOG VIDEO STBY POWER

Caution in servicing

Electrical

Mechanical

Repair Information

Updating

ANALOG PART

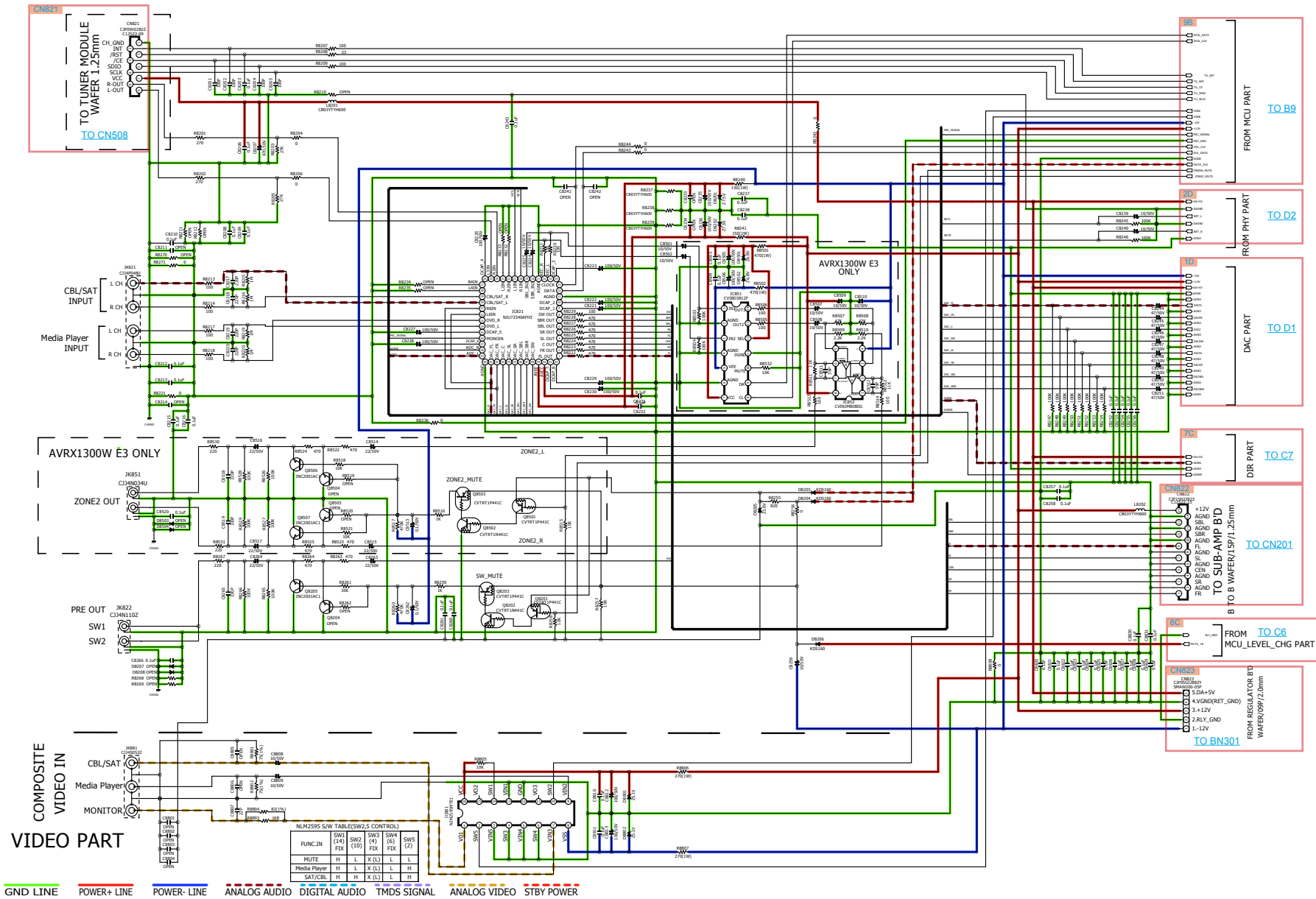

Caution in servicing

Electrical

Mechanical

Repair Information

Updating

MAIN PART

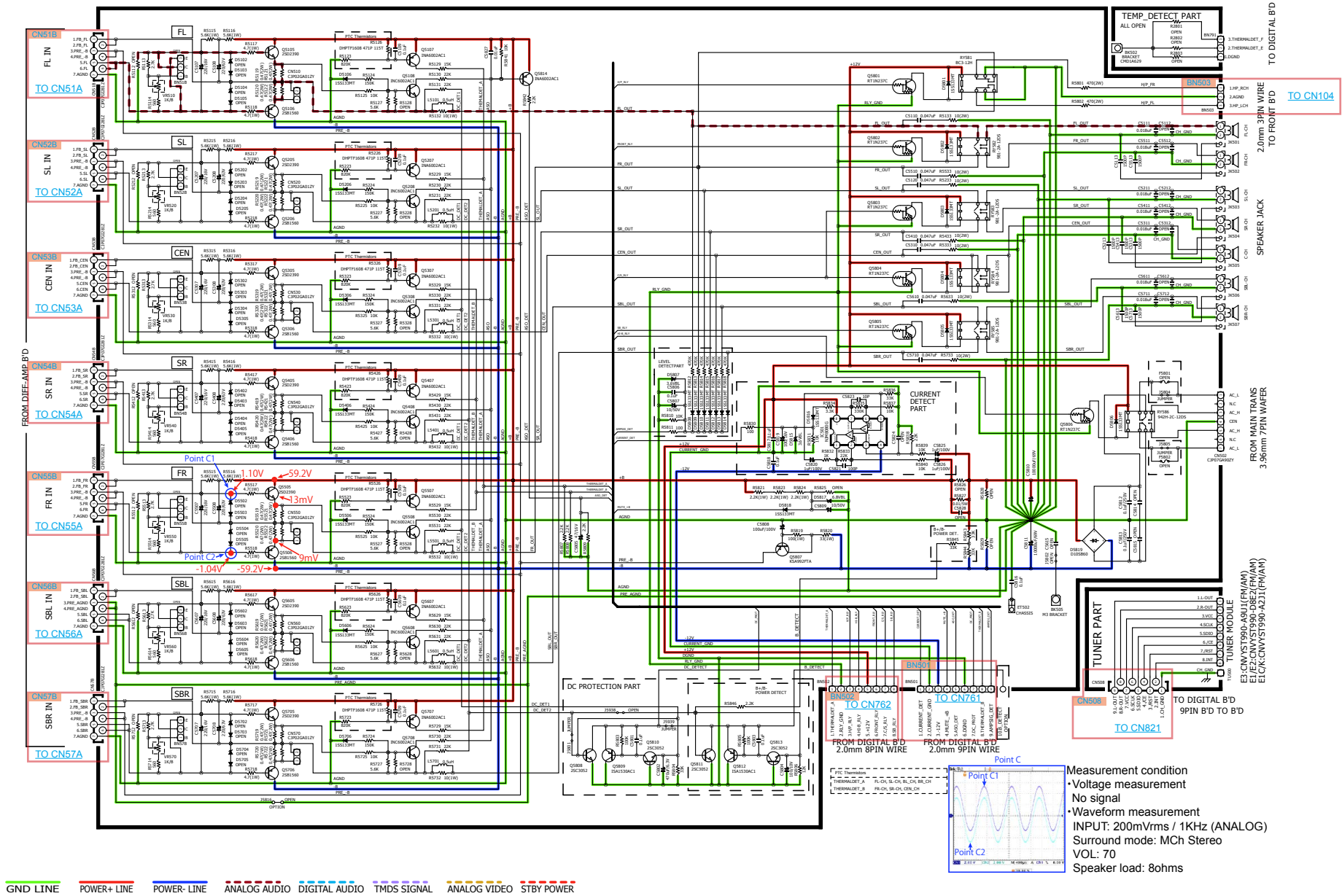

FRONT_HDMI PART

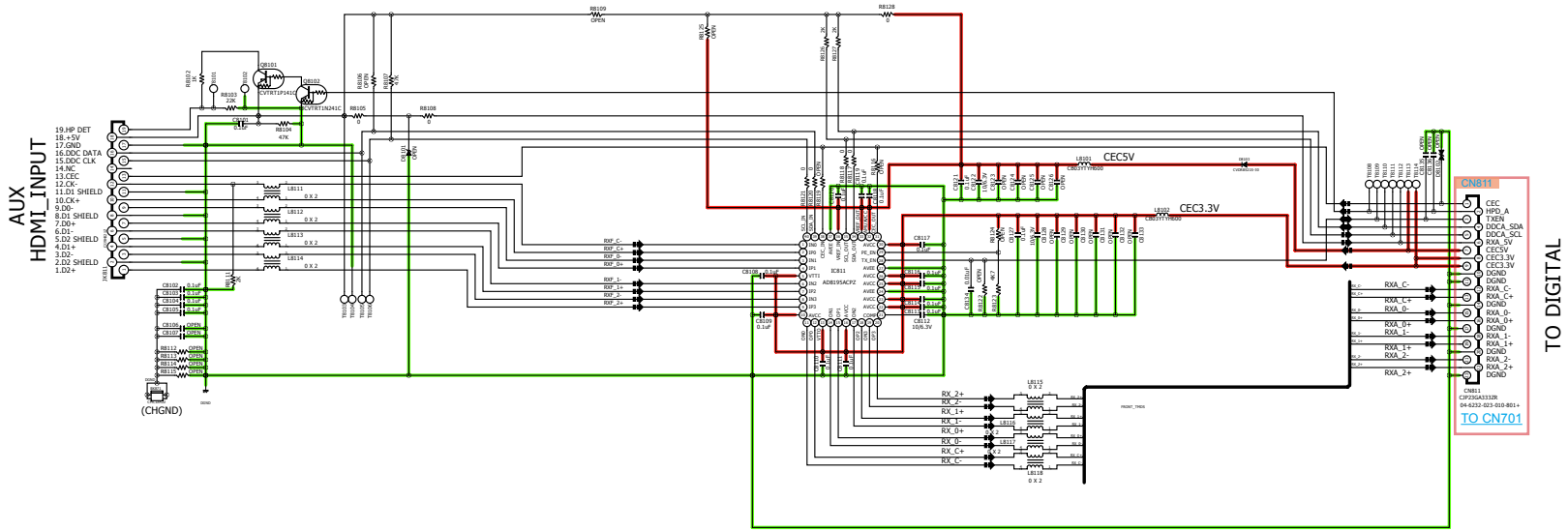

GND LINE POWER+ LINE POWER- LINE ANALOG AUDIO DIGITAL AUDIO TMDS SIGNAL ANALOG VIDEO STBY POWER

AVR-S700W/X1100W/S710W/X1200W/S720W/X1300W DIFF-AMP PART

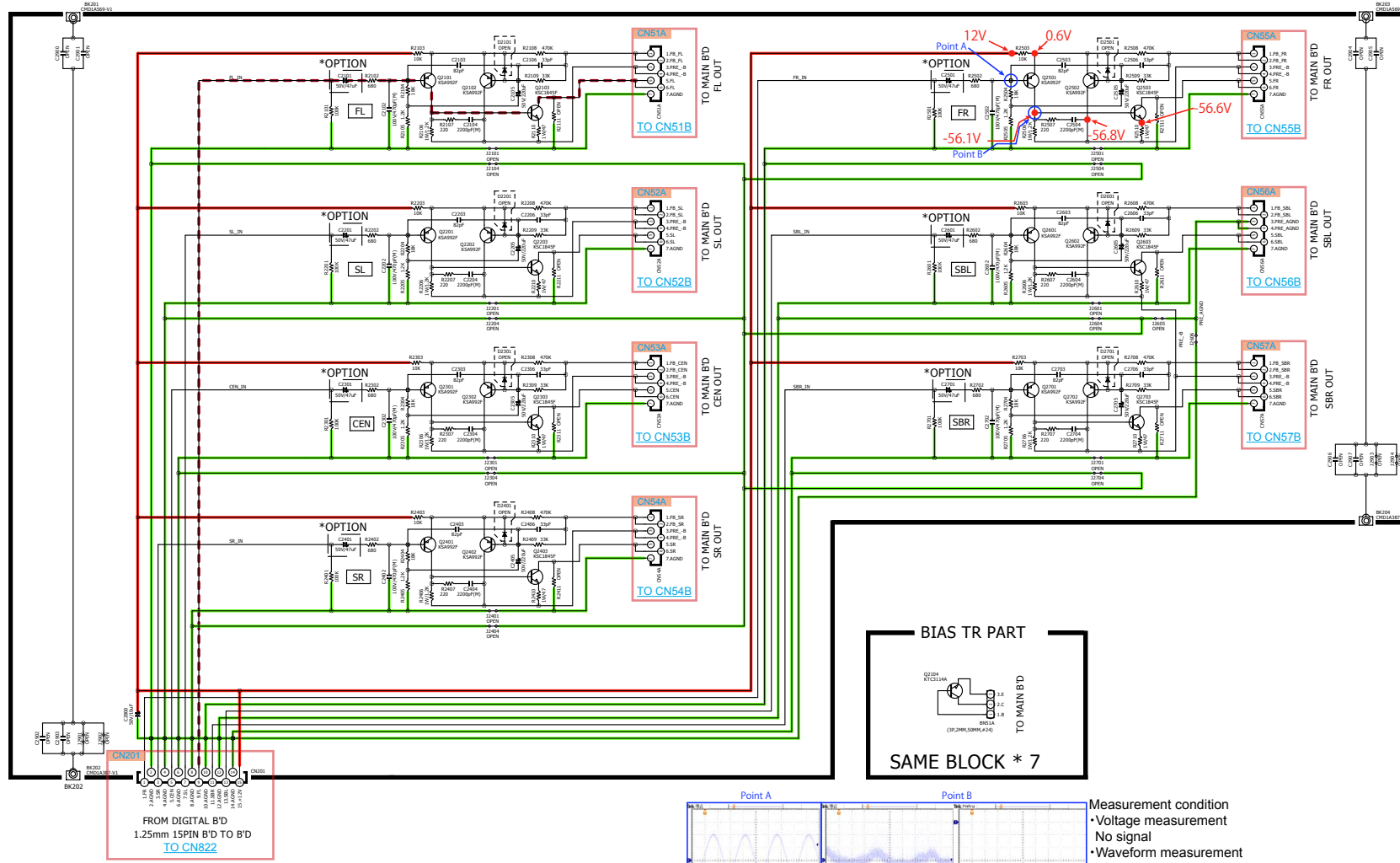

FROM DIGITAL B'D
1.25mm 15PIN B'D TO B'D
TO CN822

*OPTION

	C2101	C2201	C2301	C2401	C2501	C2601	C2701
AVR-S700W/X1100W	10uF/100V	10uF/100V	10uF/100V	10uF/100V	10uF/100V	10uF/100V	10uF/100V
AVR-S710W/X1200W	47uF/50V	47uF/50V	47uF/50V	47uF/50V	47uF/50V	47uF/50V	47uF/50V
AVR-S720W/X1300W							

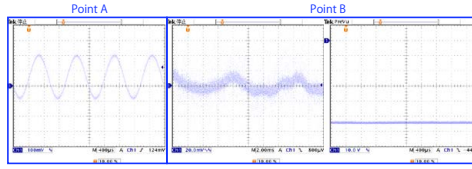
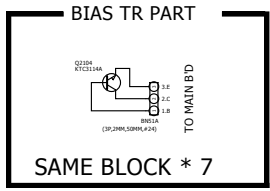

Measurement condition
 • Voltage measurement
 • No signal
 • Waveform measurement
 INPUT: 200mVrms / 1KHz (ANALOG)
 Surround mode: MCh Stereo
 VOL: 70
 Speaker load: 8ohms

GND LINE POWER+ LINE POWER- LINE ANALOG AUDIO DIGITAL AUDIO TMDS SIGNAL ANALOG VIDEO STBY POWER

FRONT PART

2.5mm 7PIN WAFER
FROM TRANS

- 7. FL_AC
- 6. NC
- 5. FL_AC
- 4. NC
- 3. GND
- 2. NC
- 1. VDSP

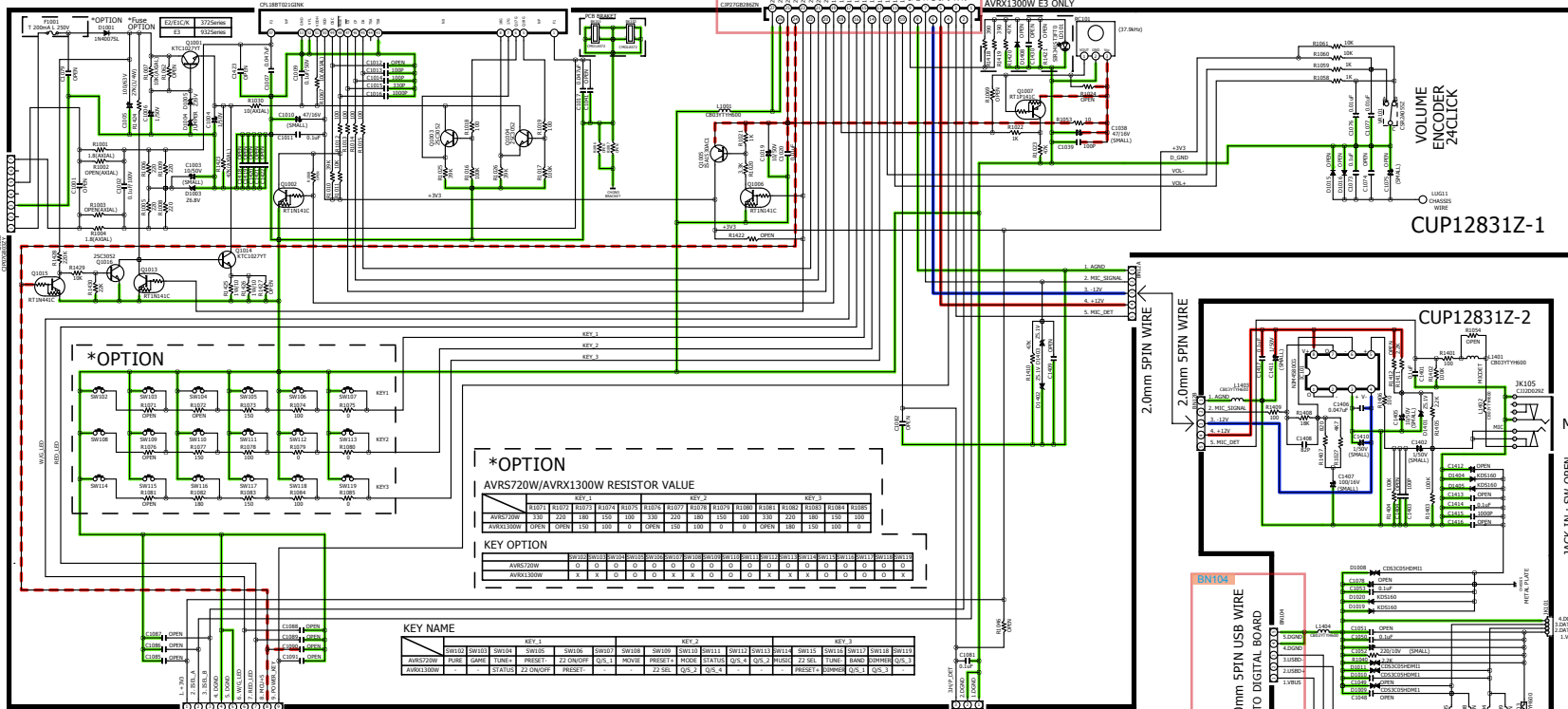

BN1081 FROM DIGITAL B'D 1.25mm 27PIN FFC TO CN751

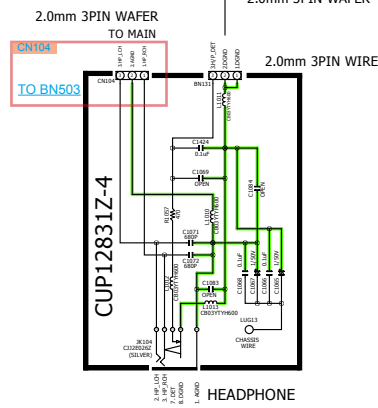
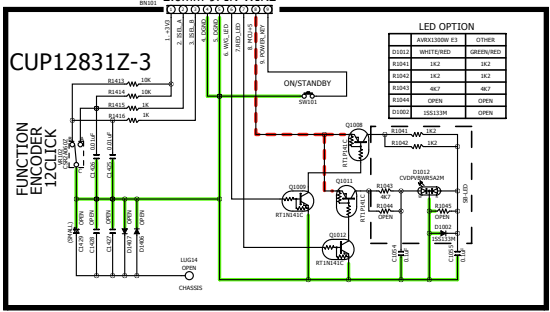
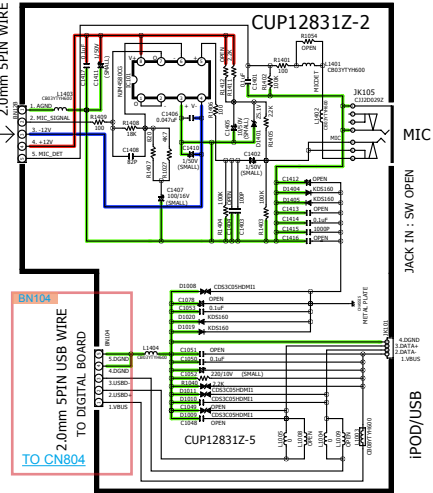

GND LINE POWER+ LINE POWER- LINE ANALOG AUDIO DIGITAL AUDIO TMS SIGNAL ANALOG VIDEO STBY POWER

REGULATOR PART

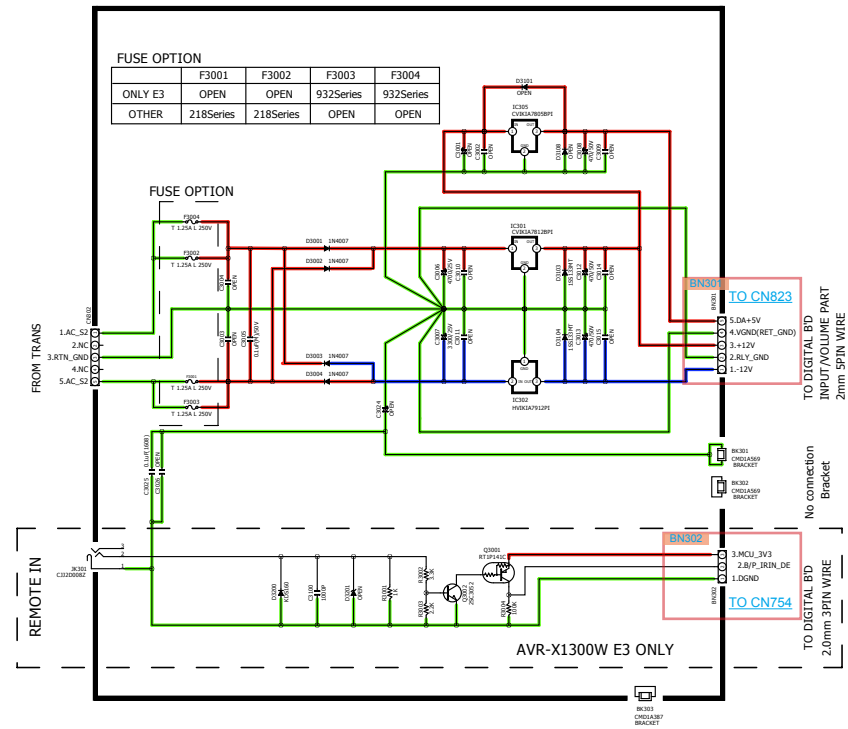

GND LINE POWER+ LINE POWER- LINE ANALOG AUDIO DIGITAL AUDIO TMD5 SIGNAL ANALOG VIDEO STBY POWER

SMPS PART

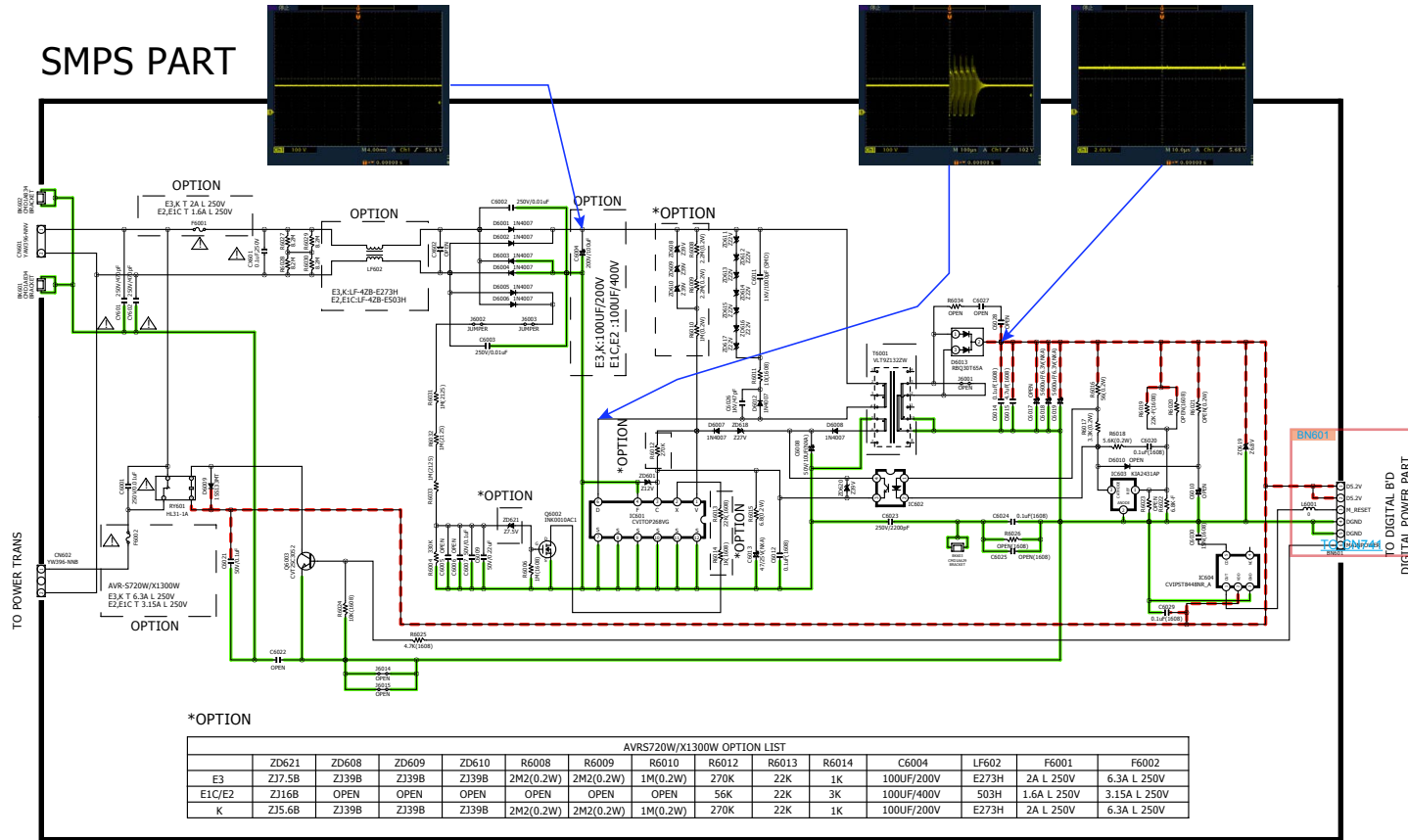

PRINTED CIRCUIT BOARDS

DIGITAL, F HDMI, TUNER, HEADPHONE, HDMI_FFC_CABLE

Lead-free Solder
When soldering, use the Lead-free Solder (Sn-Ag-Cu).

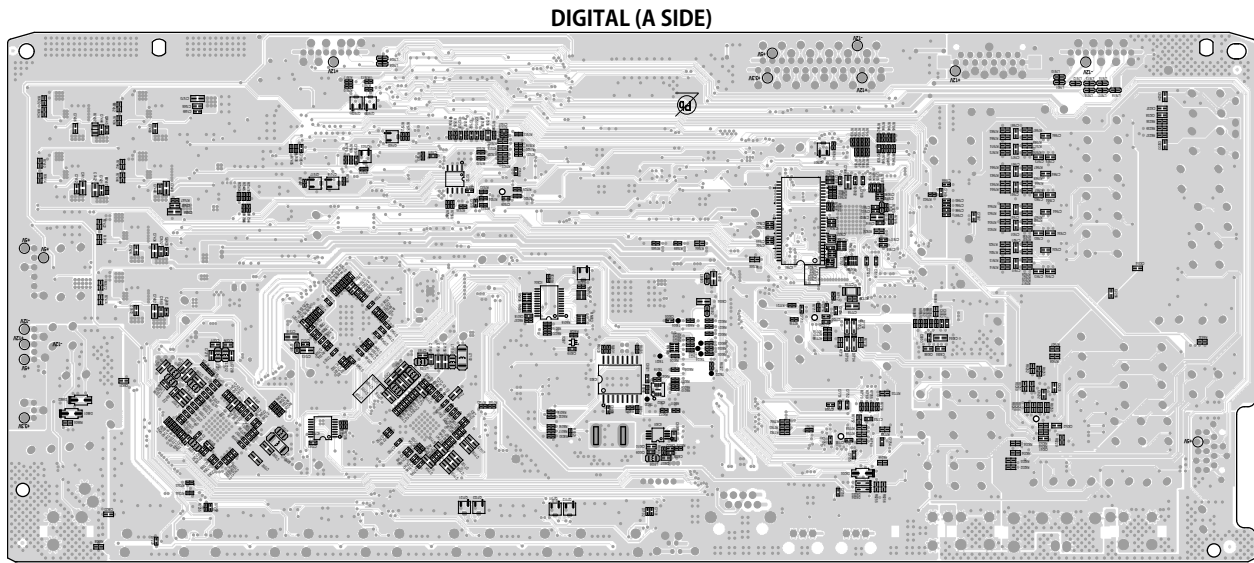
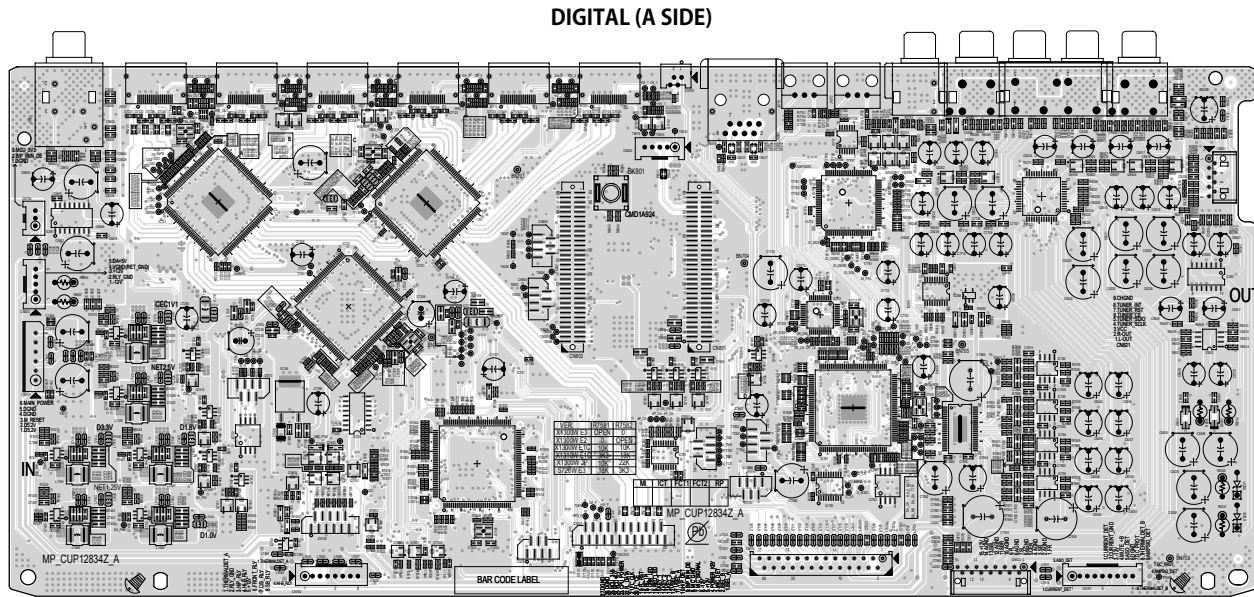

F HDMI (A SIDE)

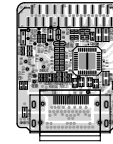

F HDMI (B SIDE)

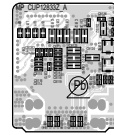

TUNER (A SIDE)

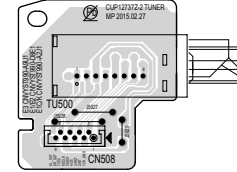

TUNER (B SIDE)

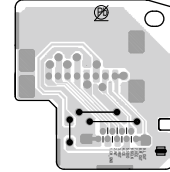

HEADPHONE (A SIDE)

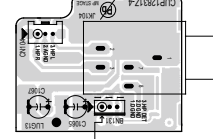

HEADPHONE (B SIDE)

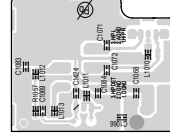

HDMI_FFC_CABLE (A SIDE)



Caution in servicing

Electrical

Mechanical

Repair Information

Updating

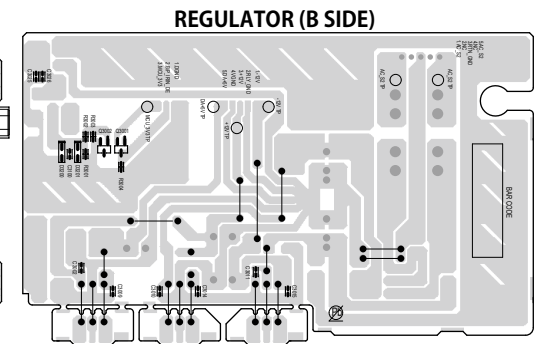
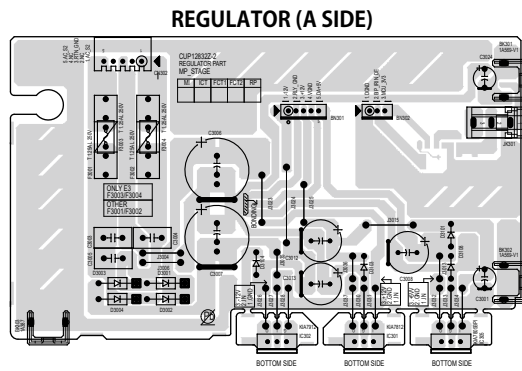
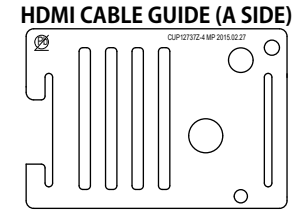
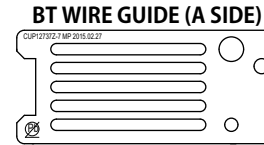
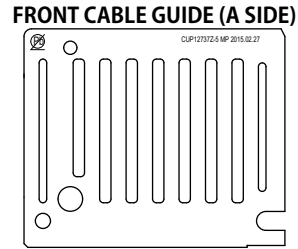
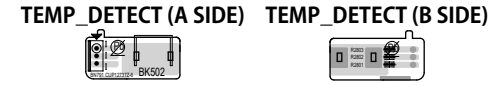
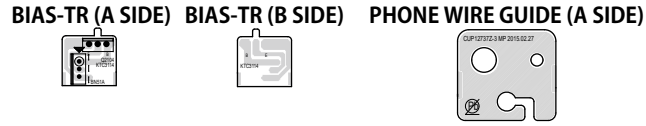
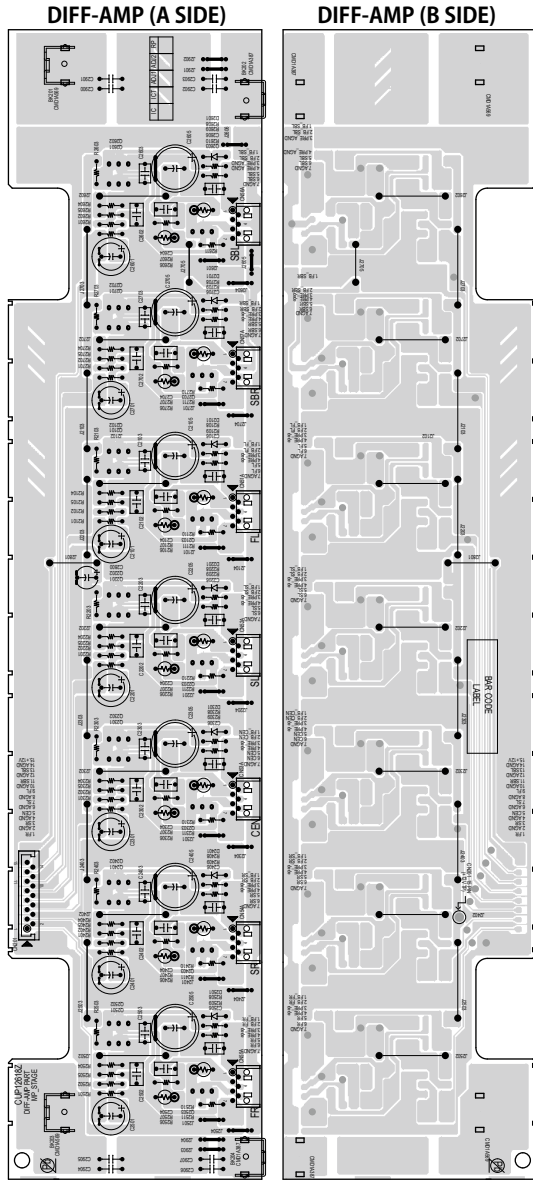

MAIM (A SIDE)

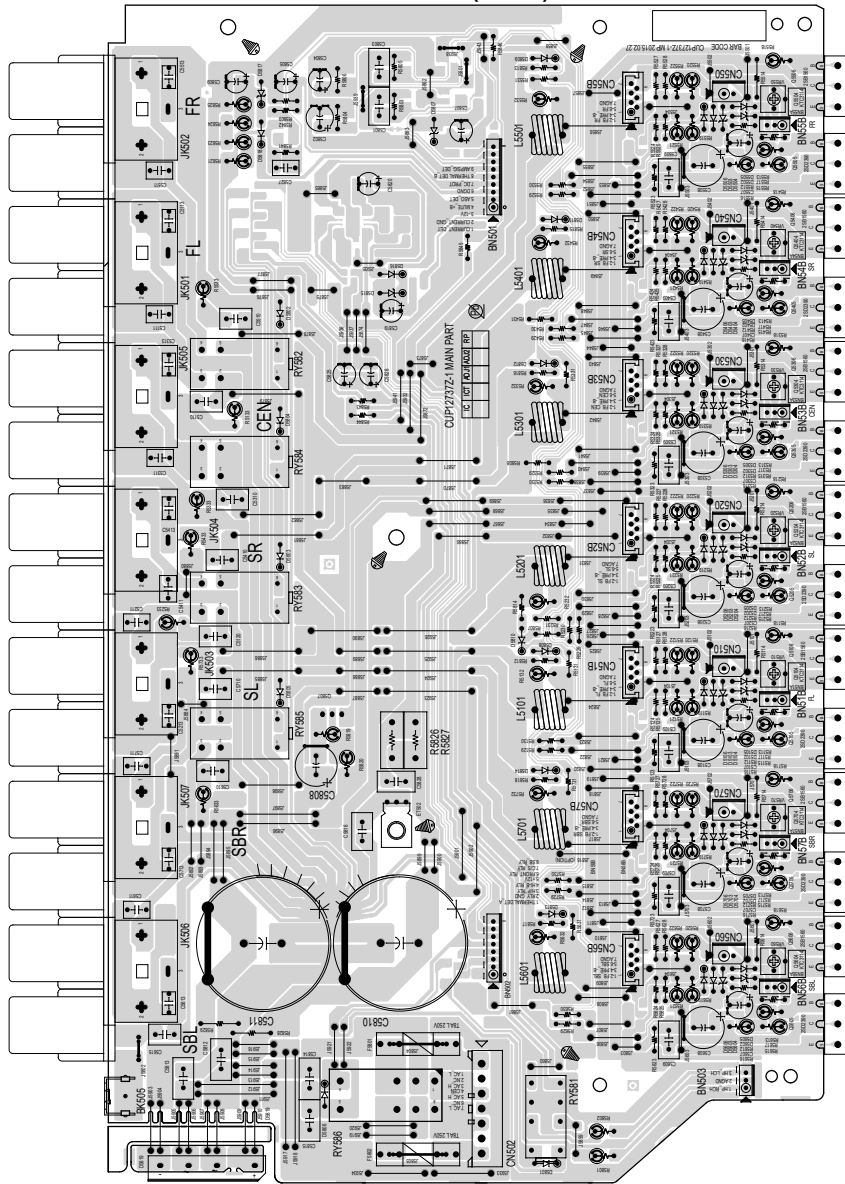

MAIM (B SIDE)

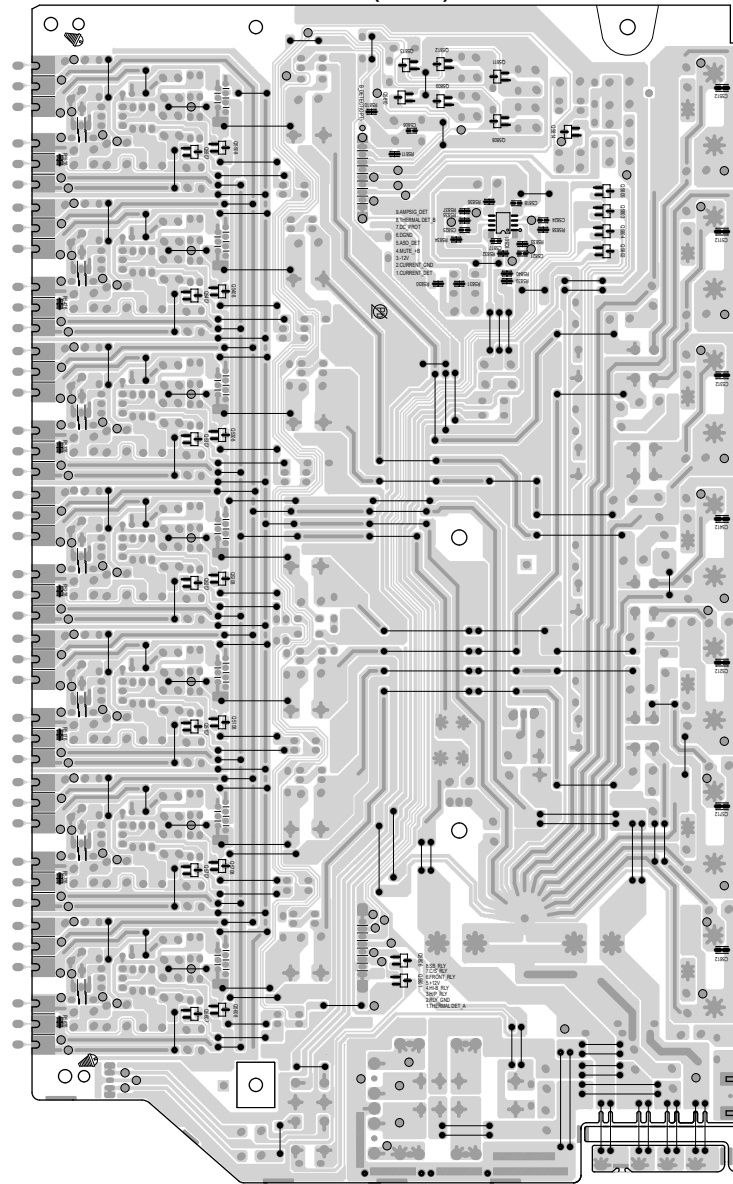

Caution in Servicing

Electrical

Mechanical

Repair Information

Updating

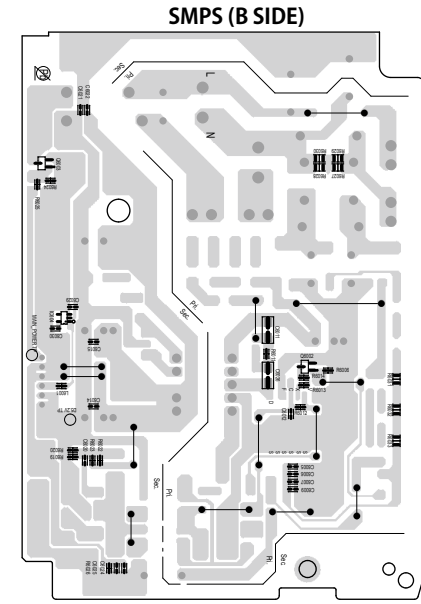
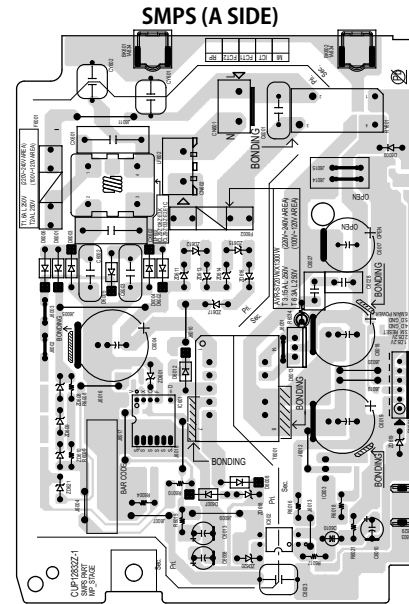
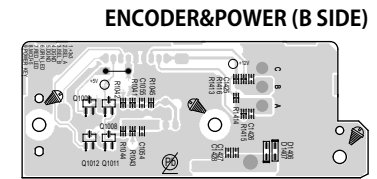
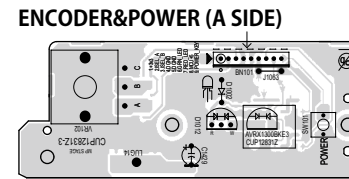
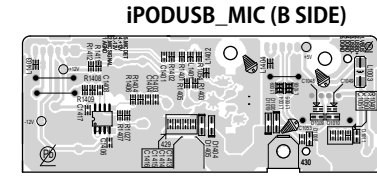
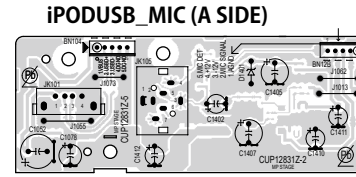
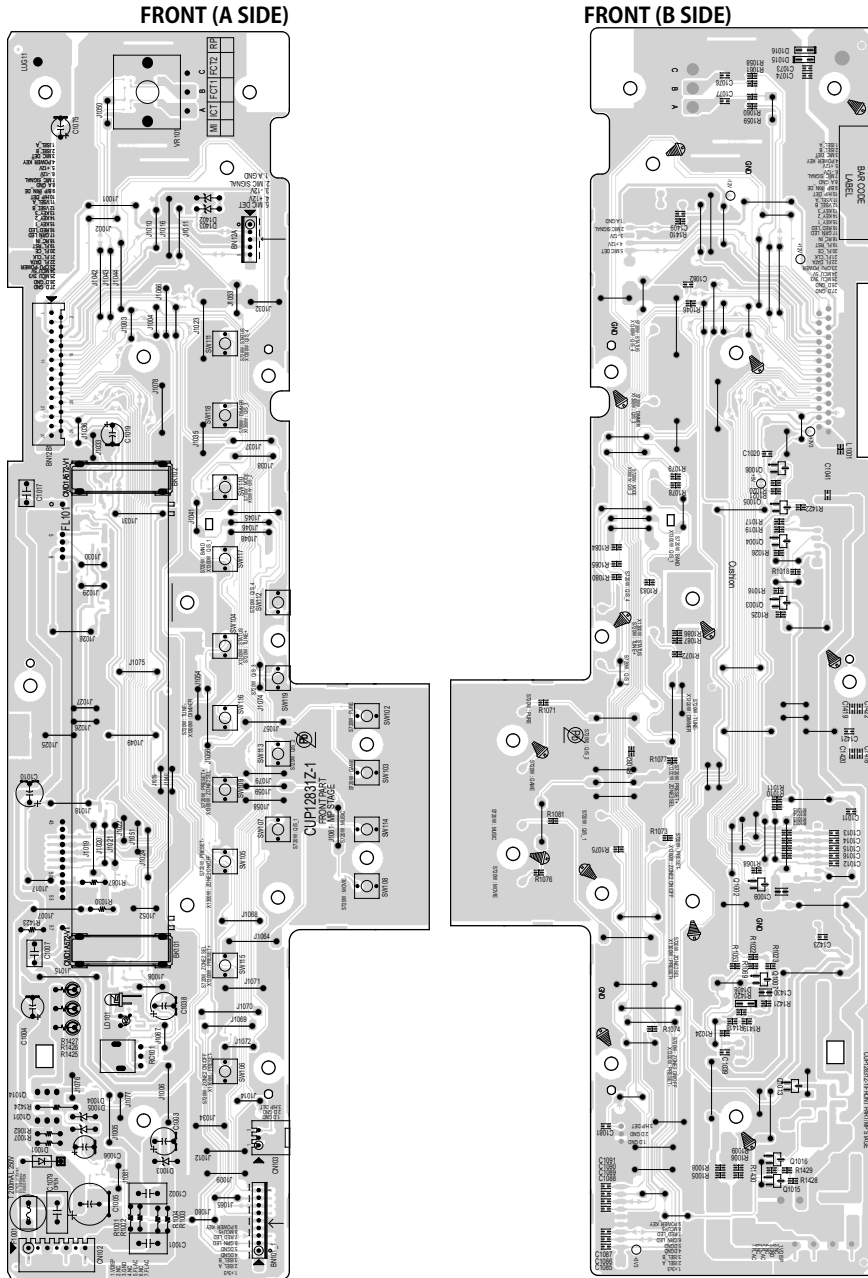

AVRS720W/X1300W LEVEL DIAGRAM

FRONT CHANNEL

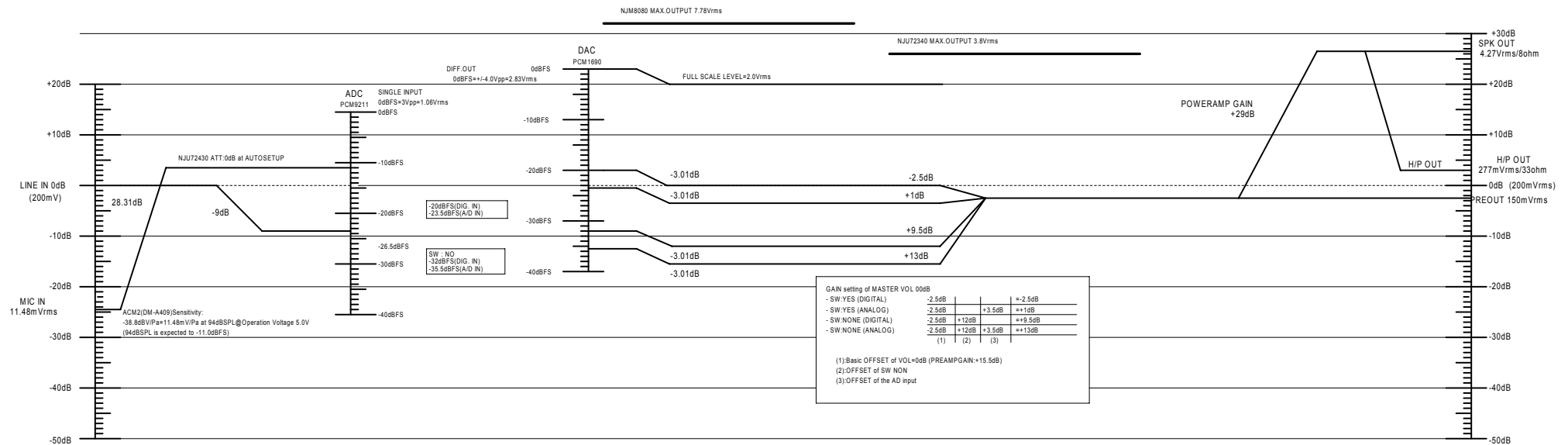
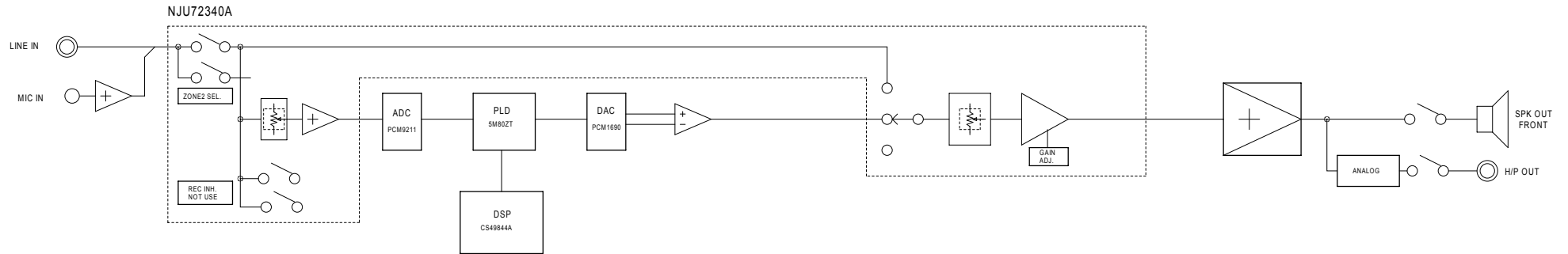

AVRS720W/X1300W LEVEL DIAGRAM

CENTER CHANNEL

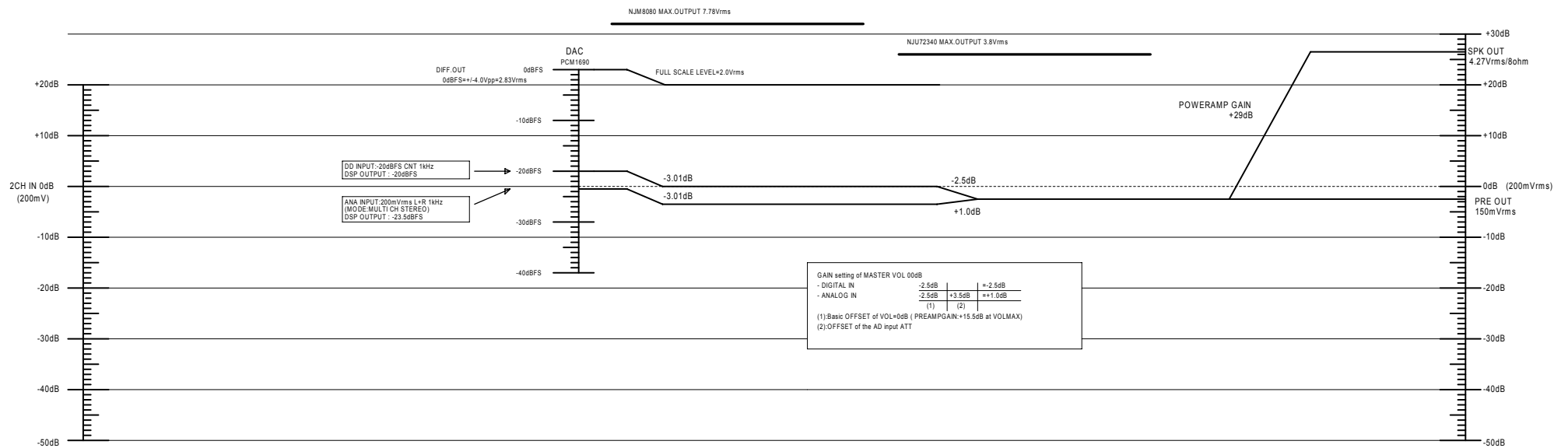
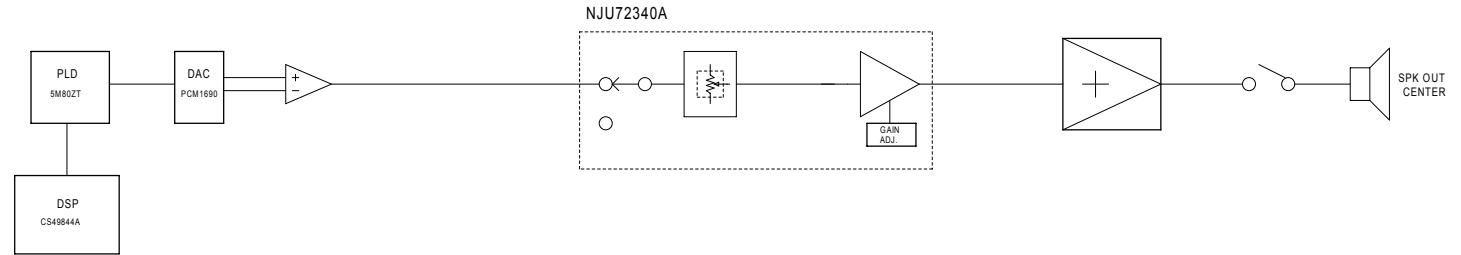

AVRS720W/X1300W LEVEL DIAGRAM

SUBWOOFER CHANNEL

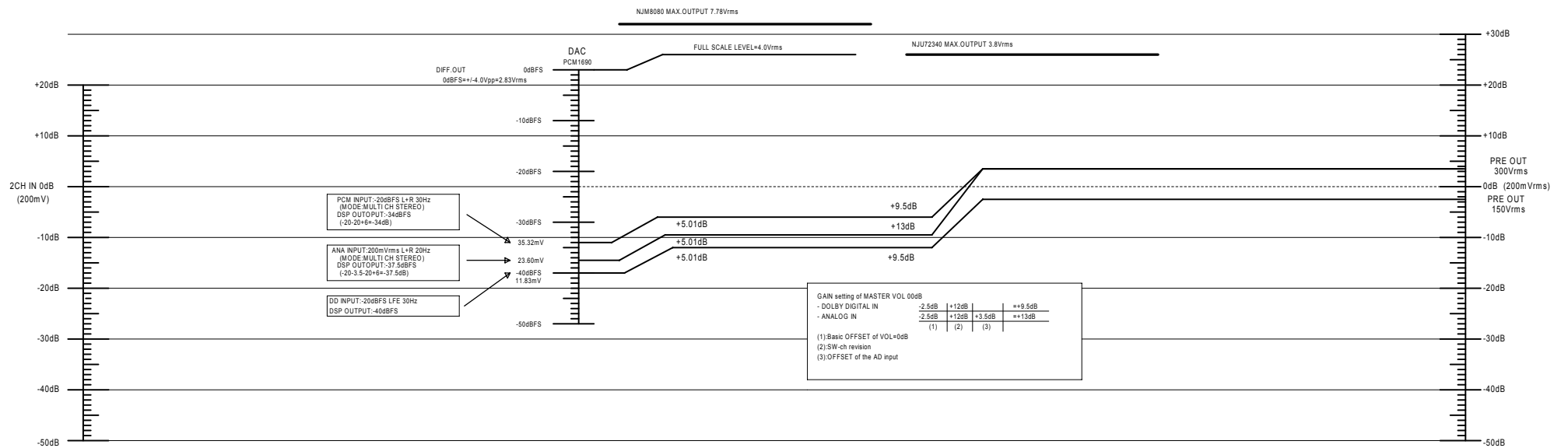
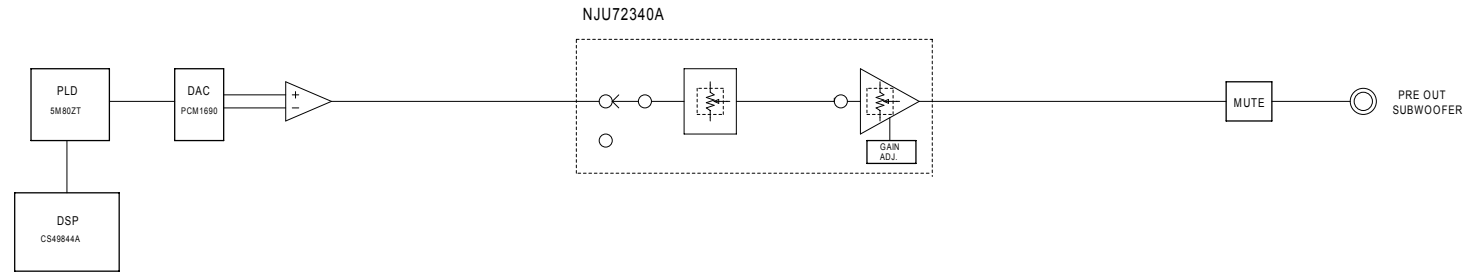

AVRS720W/X1300W LEVEL DIAGRAM

SURROUND CHANNEL

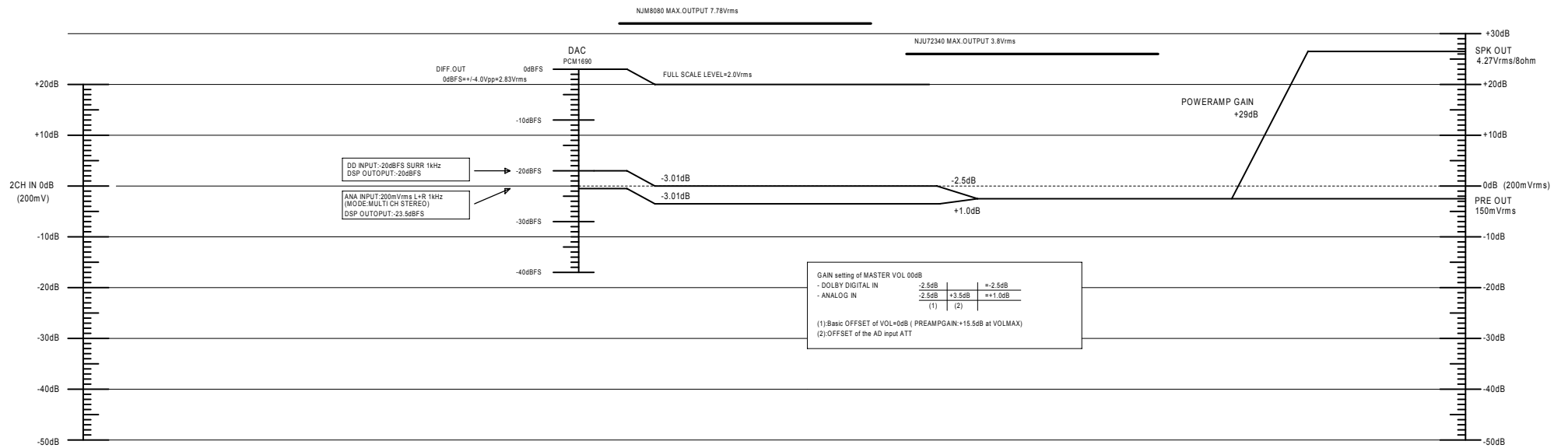
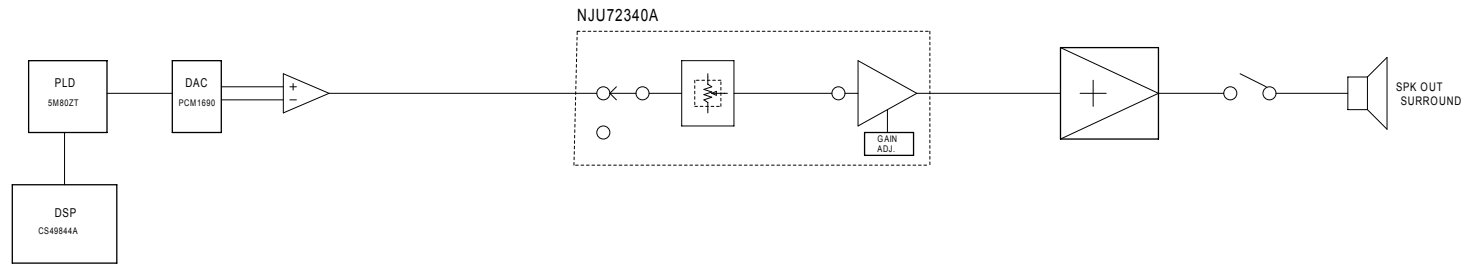

AVRS720W/X1300W LEVEL DIAGRAM

SURROUND BACK CHANNEL

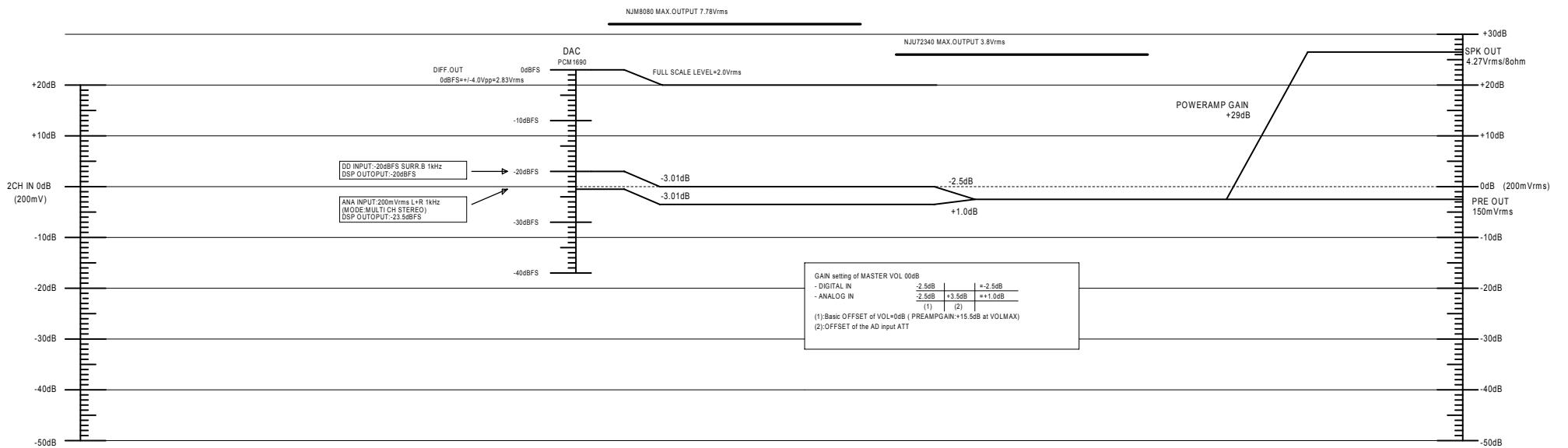
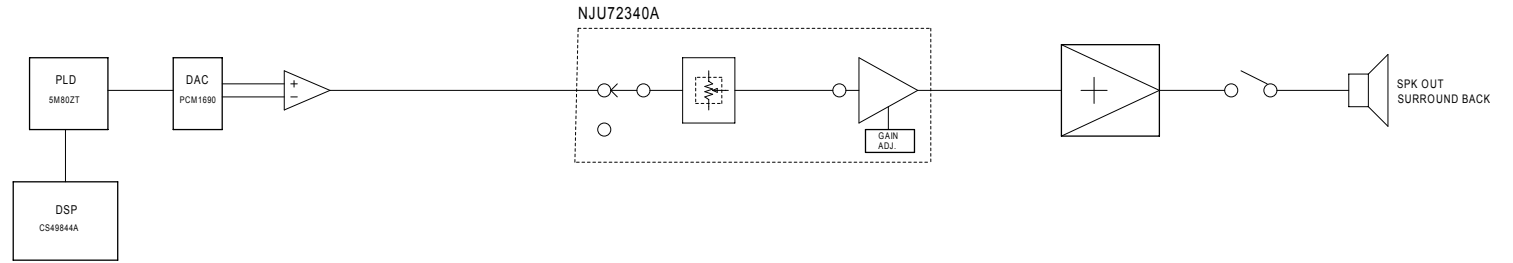

ZONE2

AVRS720W/X1300W LEVEL DIAGRAM

ZONE2

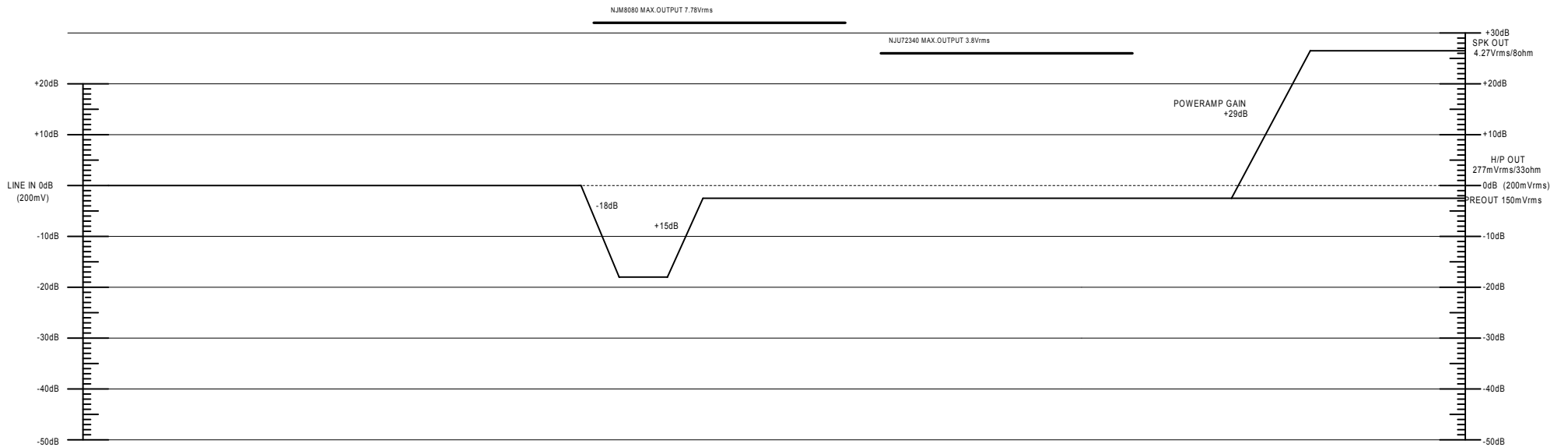
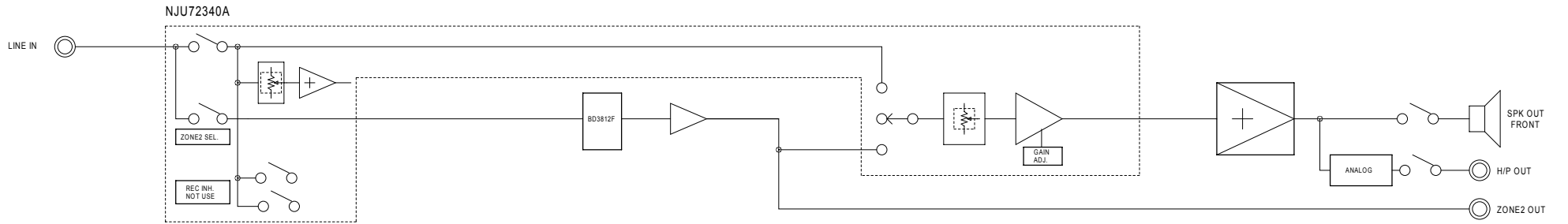

Caution in servicing

Electrical

Mechanical

Repair Information

Updating

AVRS720W/X1300W ANALOG AUDIO BLOCK

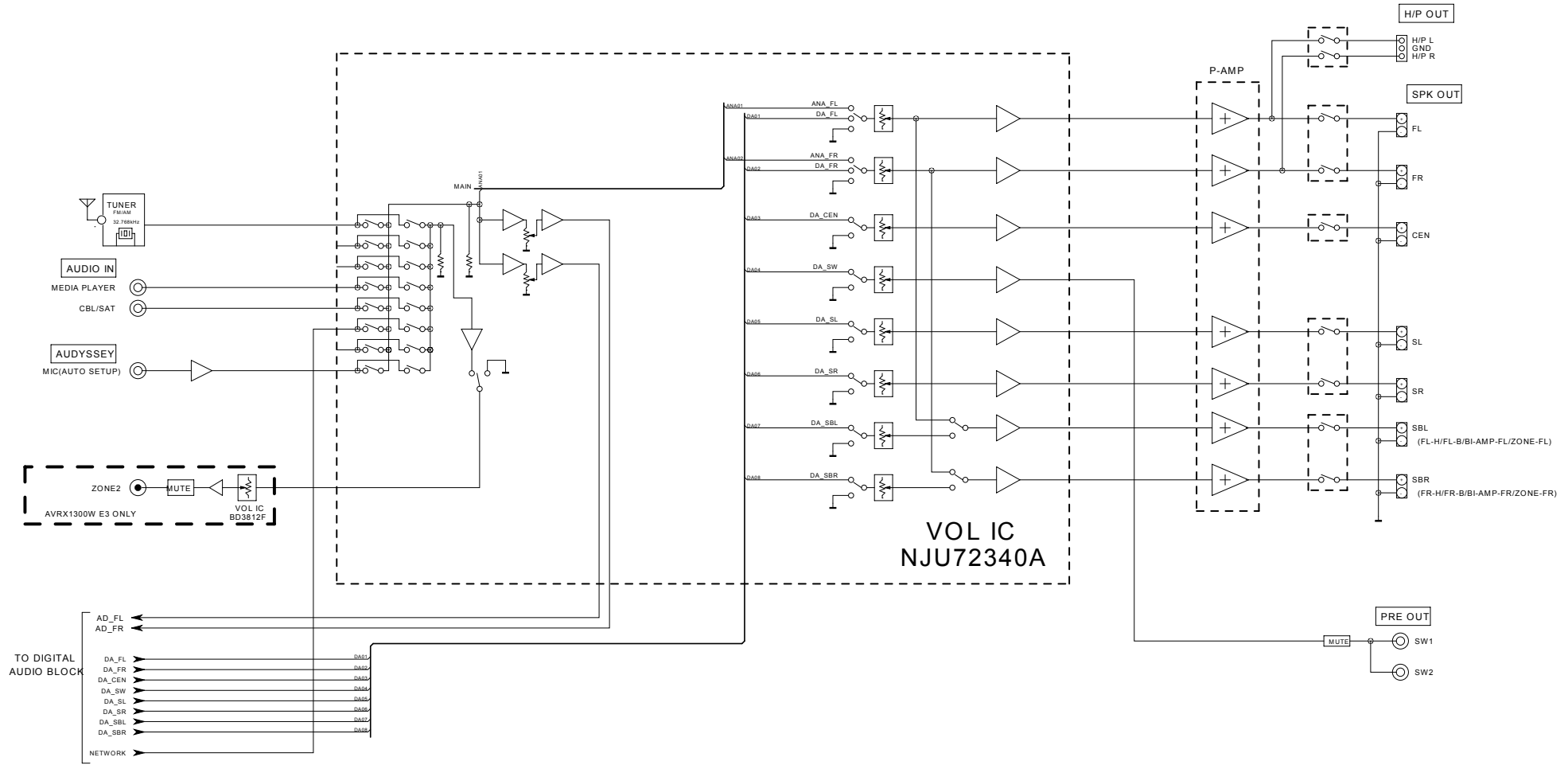

Caution in servicing

Electrical

Mechanical

Repair Information

Updating

AVRS720W/X1300W DIGITAL AUDIO BLOCK

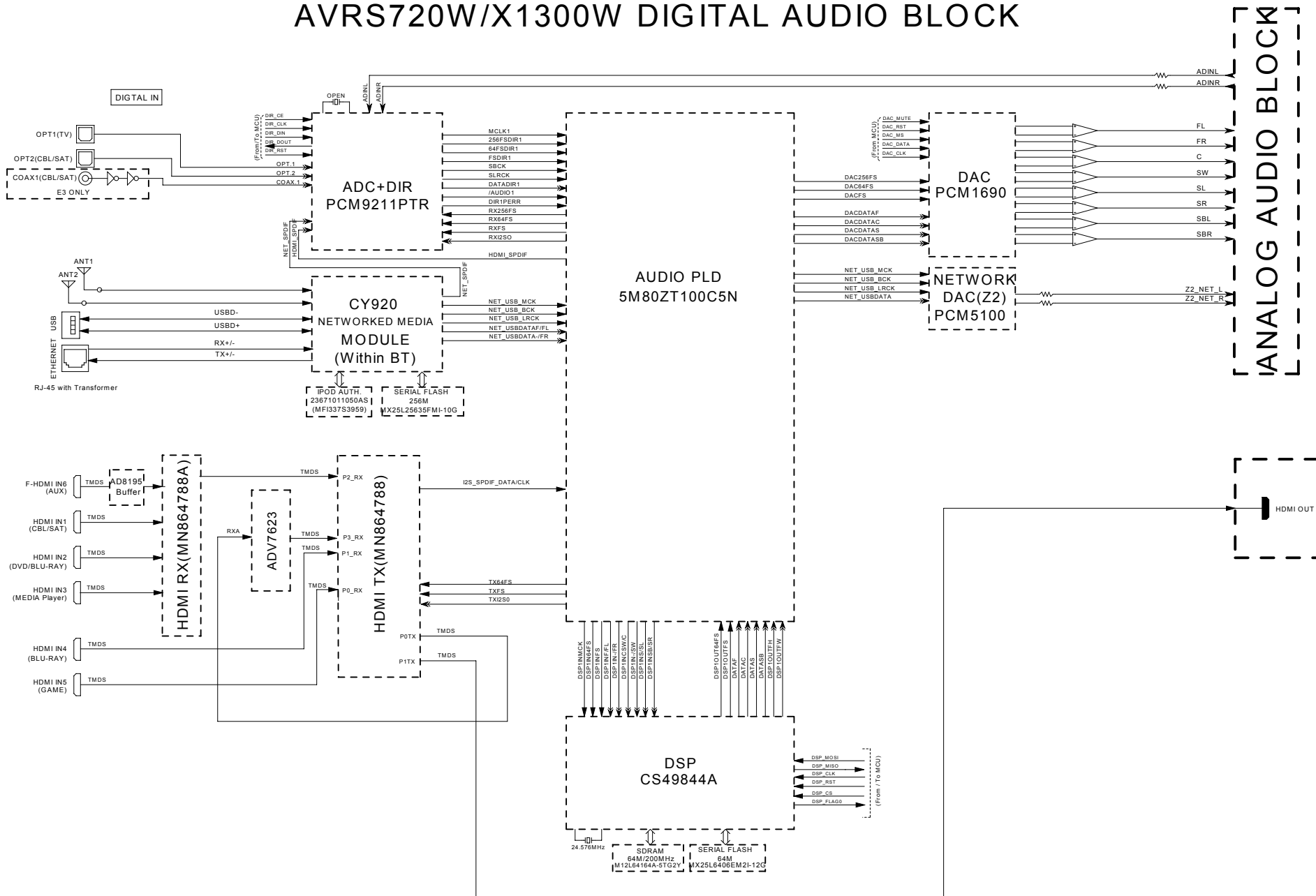

Caution in servicing

Electrical

Mechanical

Repair Information

Updating

AVRS720W/X1300W VIDEO BLOCK

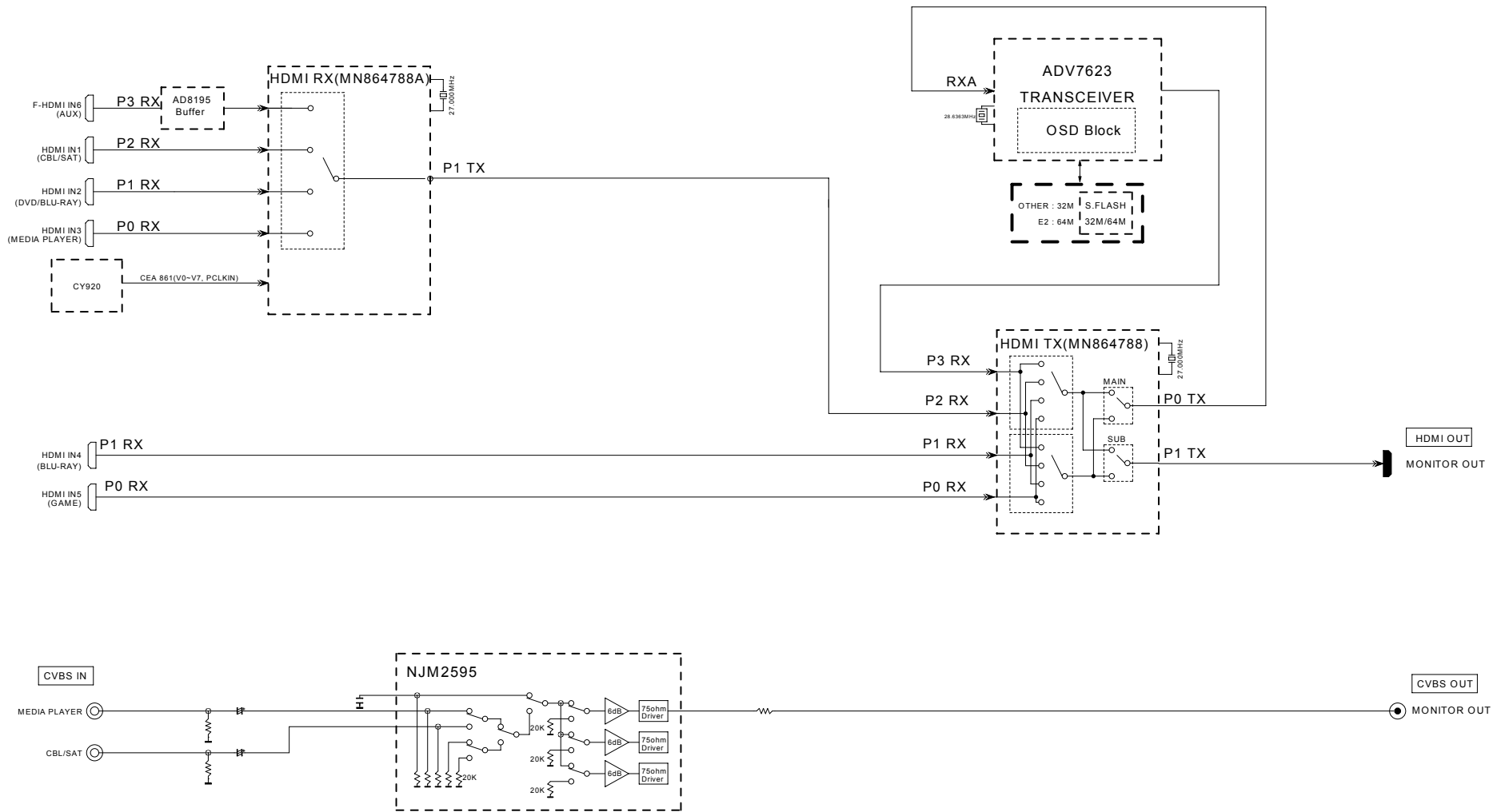

Caution in servicing

Electrical

Mechanical

Repair Information

Updating

AVRS720W/X1300W VCC DIAGRAM

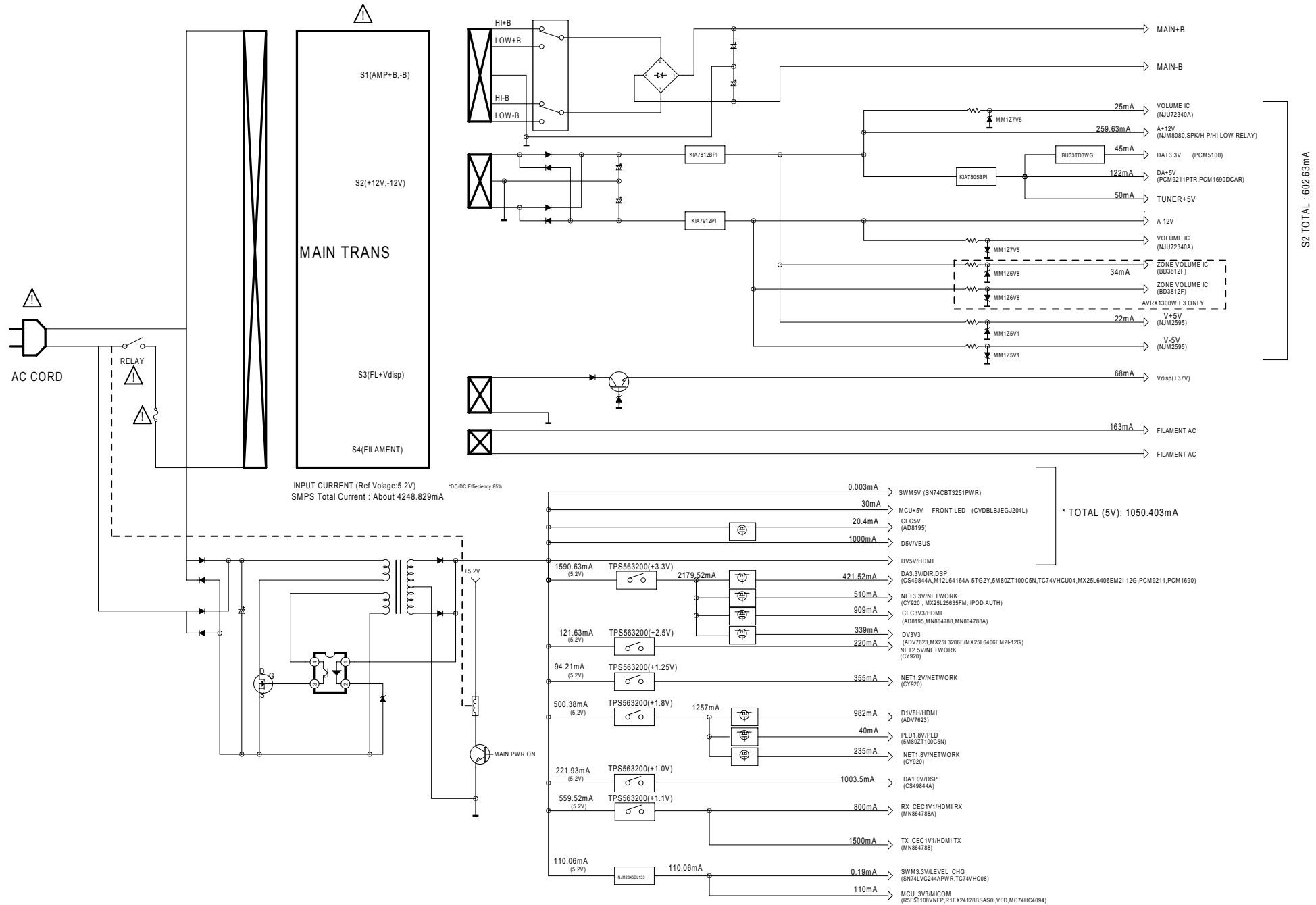

Caution in servicing

Electrical

Mechanical

Repair Information

Updating

AVRS720W/X1300W WIRING DIAGRAM

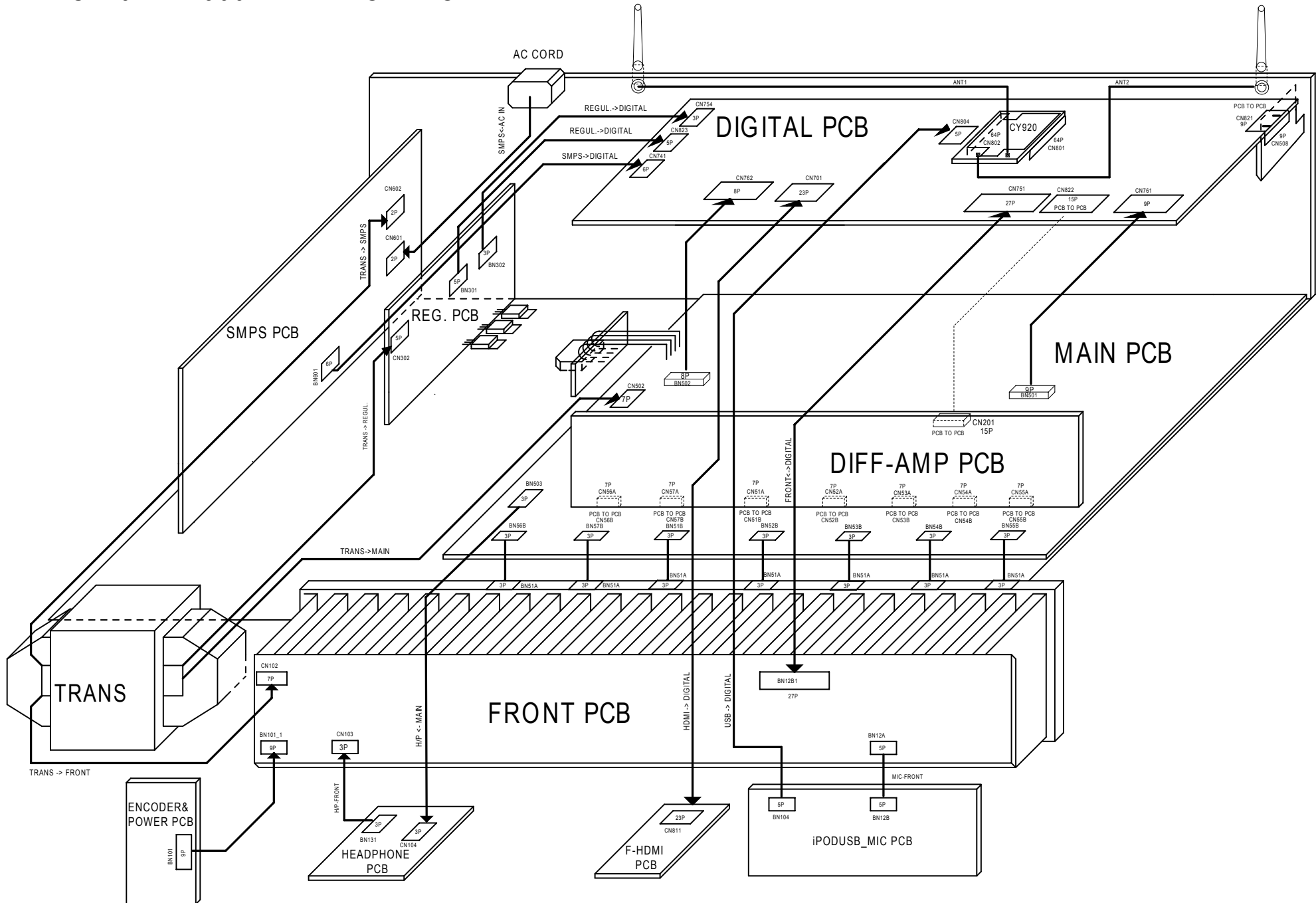

Pin No.	Mnemonic	Type	Description
13	RXC_2-	HDMI input	Digital Input Channel 2 Complement of Port C in the HDMI Interface.
14	RXC_2+	HDMI input	Digital Input Channel 2 True of Port C in the HDMI Interface.
15	HP_CTRLD	Digital output	Hot Plug Detect for Port D.
16	5V_DETD	Digital input	5 V Detect Pin for Port D in the HDMI Interface.
17	DGND	Ground	DVDD Ground.
18	DVDD	Power	Digital Supply Voltage (1.8 V).
19	DDCC_SDA	Digital I/O	HDCP Slave Serial Data Port D. DDCC_SDA is a 3.3 V input/output that is 5 V tolerant.
20	DDCC_SCL	Digital input	HDCP Slave Serial Clock Port D. DDCC_SCL is a 3.3 V input that is 5 V tolerant.
21	CVDD	Power	Receiver Comparator Supply Voltage (1.8 V).
22	CGND	Ground	TVDD and CVDD Ground.
23	RXD_C-	HDMI input	Digital Input Clock Complement of Port D in the HDMI Interface.
24	RXD_C+	HDMI input	Digital Input Clock True of Port D in the HDMI Interface.
25	TVDD	Power	Receiver Terminator Supply Voltage (3.3 V).
26	RXD_0-	HDMI input	Digital Input Channel 0 Complement of Port D in the HDMI Interface.
27	RXD_0+	HDMI input	Digital Input Channel 0 True of Port D in the HDMI Interface.
28	CGND	Ground	TVDD and CVDD Ground.
29	RXD_1-	HDMI input	Digital Input Channel 1 Complement of Port D in the HDMI Interface.
30	RXD_1+	HDMI input	Digital Input Channel 1 True of Port D in the HDMI Interface.
31	TVDD	Power	Receiver Terminator Supply Voltage (3.3 V).
32	RXD_2-	HDMI input	Digital Input Channel 2 Complement of Port D in the HDMI Interface.
33	RXD_2+	HDMI input	Digital Input Channel 2 True of Port D in the HDMI Interface.
34	CVDD	Power	Receiver Comparator Supply Voltage (1.8 V).
35	CGND	Ground	TVDD and CVDD Ground.
36	TXPVDD	Power	1.8 V Power Supply for Digital and I/O Power Supply. This pin supplies power to the digital logic and I/Os. It should be filtered and as quiet as possible.
37	TXPLVDD	Power	1.8 V Power Supply.
38	TXGND	Ground	TXPVDD Ground.
39	TXPGND	Ground	TXPLVDD Ground.
40	EXT_SWING	Analog input	This pin sets the internal reference currents. Place an 887 Ω resistor (1% tolerance) between this pin and ground.
41	HPD_ARC-	Analog input	Hot Plug Detect Signal. This pin indicates to the interface whether the receiver is connected. It supports 1.8 V to 5 V CMOS logic levels.
42	ARC+	Analog input	Audio Return Channel Input (5 V Tolerant).
43	TXDCC_SDA	Digital I/O	Serial Port Data I/O to Receiver. This pin serves as the master to the DDC bus. It supports a 5 V CMOS logic level.
44	TXDCC_SCL	Digital output	Serial Port Data Clock to Receiver. This pin serves as the master clock for the DDC bus. It supports a 5 V CMOS logic level.
45	TXAVDD	Power	1.8 V Power Supply for TMDS Outputs.
46	TXGND	Ground	TXAVDD Ground.
47	TXC-	HDMI output	Differential Clock Output. Differential clock output at the TMDS clock rate; supports TMDS logic level.
48	TXC+	HDMI output	Differential Clock Output. Differential clock output at the TMDS clock rate; supports TMDS logic level.
49	TXGND	Ground	TXAVDD Ground.
50	TX0-	HDMI output	Differential Output Channel 0 Complement. Differential output of the red data at 10x the pixel clock rate; supports TMDS logic level.
51	TX0+	HDMI output	Differential Output Channel 0 True. Differential output of the red data at 10x the pixel clock rate; supports TMDS logic level.
52	TXGND	Ground	TXAVDD Ground.
53	TX1-	HDMI output	Differential Output Channel 1 Complement. Differential output of the red data at 10x the pixel clock rate; supports TMDS logic level.
54	TX1+	HDMI output	Differential Output Channel 1 True. Differential output of the red data at 10x the pixel clock rate; supports TMDS logic level.
55	TXAVDD	Power	1.8 V Power Supply for TMDS Outputs.

Pin No.	Mnemonic	Type	Description
99	PGND	Ground	PVDD Ground.
100	PVDD	Power	PLL Supply Voltage (1.8 V).
101	XTAL	Miscellaneous analog	Input pin for 28.63636 MHz crystal or an external 1.8 V 28.63636 MHz clock oscillator source to clock the ADV7623.
102	XTAL1	Miscellaneous analog	Crystal Output Pin. This pin should be left floating if a clock oscillator is used.
103	PVDD	Power	PLL Supply Voltage (1.8 V).
104	PGND	Ground	PVDD Ground.
105	HP_CTRLA	Digital output	Hot Plug Detect for Port A.
106	5V_DETA	Digital input	5 V Detect Pin for Port A in the HDMI Interface.
107	RTERM	Miscellaneous analog	This pin sets the internal termination resistance. A 500 Ω resistor between this pin and ground should be used.
108	DDCA_SDA	Digital I/O	HDCP Slave Serial Data Port A. DDCA_SDA is a 3.3 V input/output that is 5 V tolerant.
109	DDCA_SCL	Digital input	HDCP Slave Serial Clock Port A. DDCA_SCL is a 3.3 V input that is 5 V tolerant.
110	CVDD	Power	Receiver Comparator Supply Voltage (1.8 V).
111	CGND	Ground	TVDD and CVDD Ground.
112	RXA_C-	HDMI input	Digital Input Clock Complement of Port A in the HDMI Interface.
113	RXA_C+	HDMI input	Digital Input Clock True of Port A in the HDMI Interface.
114	TVDD	Power	Receiver Terminator Supply Voltage (3.3 V).
115	RXA_0-	HDMI input	Digital Input Channel 0 Complement of Port A in the HDMI Interface.
116	RXA_0+	HDMI input	Digital Input Channel 0 True of Port A in the HDMI Interface.
117	CGND	Ground	TVDD and CVDD Ground.
118	RXA_1-	HDMI input	Digital Input Channel 1 Complement of Port A in the HDMI Interface.
119	RXA_1+	HDMI input	Digital Input Channel 1 True of Port A in the HDMI Interface.
120	TVDD	Power	Receiver Terminator Supply Voltage (3.3 V).
121	RXA_2-	HDMI input	Digital Input Channel 2 Complement of Port A in the HDMI Interface.
122	RXA_2+	HDMI input	Digital Input Channel 2 True of Port A in the HDMI Interface.
123	HP_CTRLB	Digital output	Hot Plug Detect for Port B.
124	5V_DETB	Digital input	5 V Detect Pin for Port B in the HDMI Interface.
125	DGND	Ground	DVDD Ground.
126	DVDD	Power	Digital Supply Voltage (1.8 V).
127	DDCB_SDA	Digital I/O	HDCP Slave Serial Data Port B. DDCB_SDA is a 3.3 V input/output that is 5 V tolerant.
128	DDCB_SCL	Digital input	HDCP Slave Serial Clock Port B. DDCB_SCL is a 3.3 V input that is 5 V tolerant.
129	CVDD	Power	Receiver Comparator Supply Voltage (1.8 V).
130	CGND	Ground	TVDD and CVDD Ground.
131	RXB_C-	HDMI input	Digital Input Clock Complement of Port B in the HDMI Interface.
132	RXB_C+	HDMI input	Digital Input Clock True of Port B in the HDMI Interface.
133	TVDD	Power	Receiver Terminator Supply Voltage (3.3 V).
134	RXB_0-	HDMI input	Digital Input Channel 0 Complement of Port B in the HDMI Interface.
135	RXB_0+	HDMI input	Digital Input Channel 0 True of Port B in the HDMI Interface.
136	CGND	Ground	TVDD and CVDD Ground.
137	RXB_1-	HDMI input	Digital Input Channel 1 Complement of Port B in the HDMI Interface.
138	RXB_1+	HDMI input	Digital Input Channel 1 True of Port B in the HDMI Interface.
139	TVDD	Power	Receiver Terminator Supply Voltage (3.3 V).
140	RXB_2-	HDMI input	Digital Input Channel 2 Complement of Port B in the HDMI Interface.
141	RXB_2+	HDMI input	Digital Input Channel 2 True of Port B in the HDMI Interface.
142	HP_CTRLC	Digital output	Hot Plug Detect for Port C.
143	5V_DETC	Digital input	5 V Detect Pin for Port C in the HDMI Interface.
144	DDCC_SDA	Digital I/O	HDCP Slave Serial Data Port C. DDCC_SDA is a 3.3 V input/output that is 5 V tolerant.

ADV7623 Block diagram

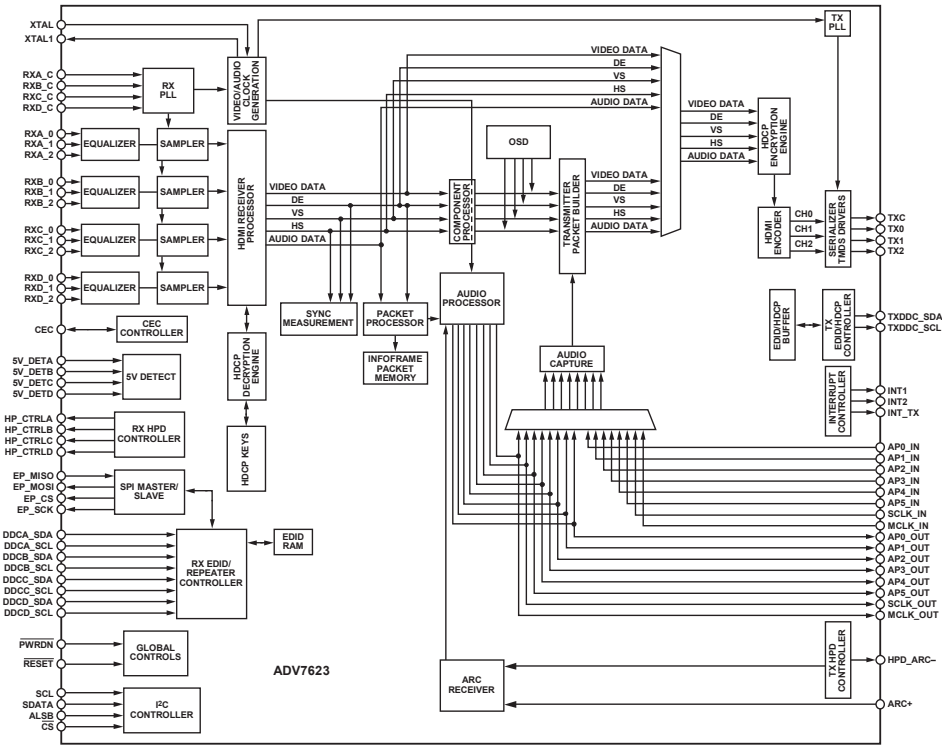

DIGITAL_HDMI_ADV7623 : IC732

MX25L3206EM2I-12G (except : E2)
MX25L6406EM2I-12G (ONLY E2)

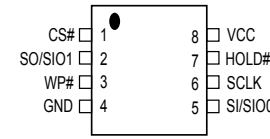

PIN DESCRIPTION

SYMBOL	DESCRIPTION
CS#	Chip Select
SI/SIO0	Serial Data Input (for 1 x I/O/ Serial Data Input & Output (for Dual Output mode)
SO/SIO1	Serial Data Output (for 1 x I/O/ Serial Data Output (for Dual Output mode)
SCLK	Clock Input
WP#	Write protection
HOLD#	Hold, to pause the device without deselection of the device
VCC	+ 3.3V Power Supply
GND	Ground

SN74CBT3251PWR (DIGITAL_HDMI_ADV7623 : IC733)

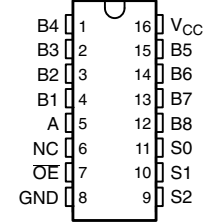

Block diagram

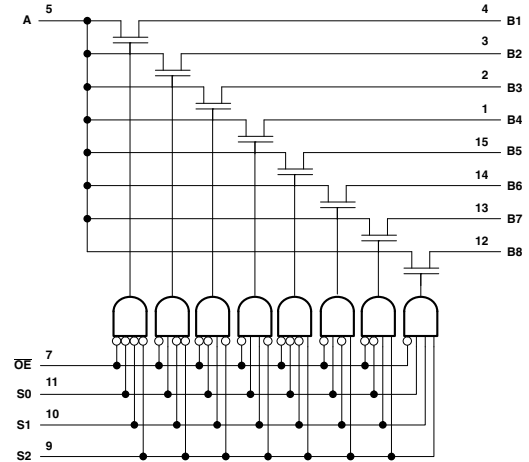

TPS563200 (DIGITAL_DIGITAL SUPPLY : IC741~745, 747)

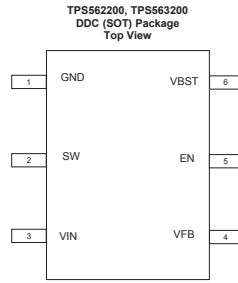

Terminal Functions

PIN		DESCRIPTION
NAME	NUMBER	
GND	1	Ground pin Source terminal of low-side power NFET as well as the ground terminal for controller circuit. Connect sensitive VFB to this GND at a single point.
SW	2	Switch node connection between high-side NFET and low-side NFET.
VIN	3	Input voltage supply pin. The drain terminal of high-side power NFET.
VFB	4	Converter feedback input. Connect to output voltage with feedback resistor divider.
EN	5	Enable input control. Active high and must be pulled up to enable the device.
VBST	6	Supply input for the high-side NFET gate drive circuit. Connect a 0.1 μ F capacitor between VBST and SW pins.

Block diagram

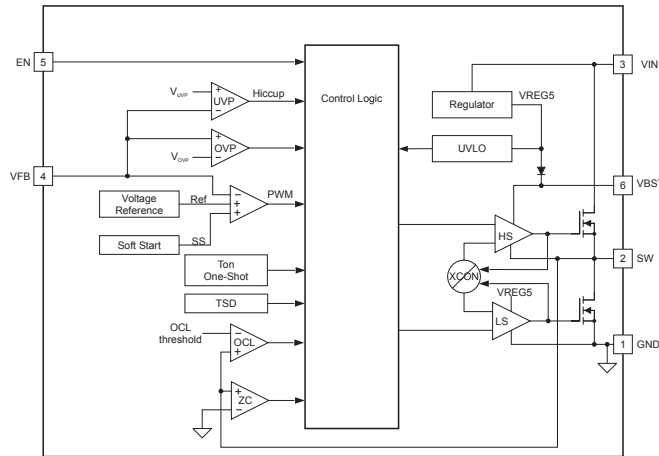

R5F56108VNFP (DIGITAL_MCU : IC751)

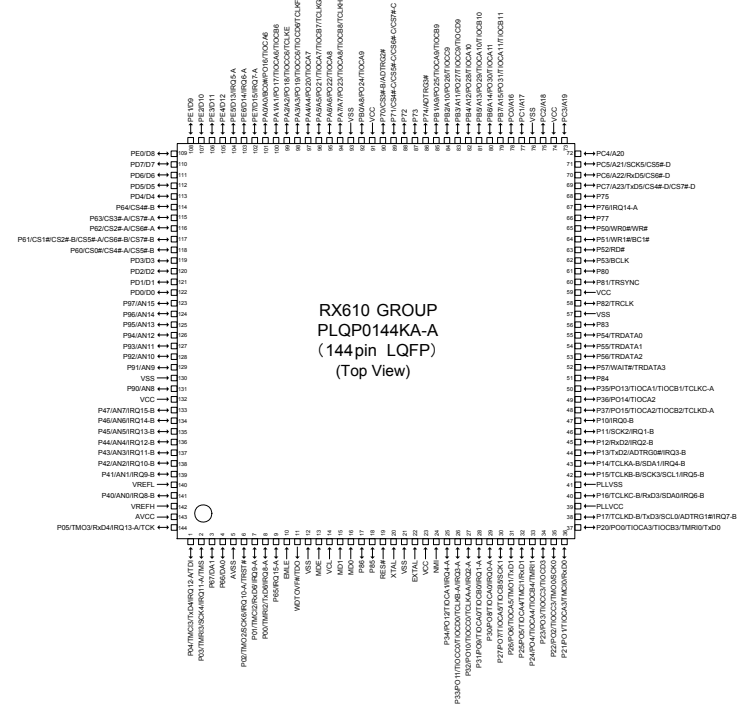

RX610 GROUP PLQP0144KA-A (144 pin LQFP) (Top View)

R5F56108VNFP Terminal Functions

Pin	Pin Name	Symbol	I/O	Pu/Pd	STBY	STOP	CEC STBY	Function
1	P04/IRQ12-A/TMC13/TxD4/TDI	TDI/TXD MITSUBISHI/NC(NORMRAL)	I/O/I	M3VPu	-/-/I	-/-/I	I	E20 Emulator control pin/Mitsubishi writer control pin/When normal operating mode,set to input.
2	P03/IRQ11-A/TMRI3/SCK4/TMS	TMS/NC(NORMRAL)	I/I	M3VPu	-/I	-/I	I	E20 Emulator control pin/When normal operating mode,set to input.
3	P67/DA1	HIN SELA	O	L	L	L	L	HDMI +5V selector (TC4051) control pin
4	P66/DA0	HIN SELB	O	L	L	L	L	HDMI +5V selector (TC4051) control pin
5	AVSS	AVSS	-	-	-	-	-	Ground pin
6	P02/IRQ10-A/TMO2/SCK6/TRST#	TRST#/NC(NORMRAL)	I/I	Pd	I/I	I/I	I	E20 Emulator control pin/When normal operating mode is set to input.
7	P01/IRQ9-A/TMC12/RxD6	RXD M1232O	I	M3VPu	I	I	I	External data input port (for AMX/FW update via 232C) :Connector is FFC
8	P00/IRQ8-A/TMRI2/TxD6	TXD MO232I	O	L	L	L	L	External data output port (for AMX/FW update via 232C) :Connector is FFC
9	P65/IRQ15-A	POWER KEY	I	M3VPu	I	I	I	Detect Power switch (Release from Wait Mode,Set to interrupt)
10	EMLE	EMLE	I	Pd	-	-	-	E20 Emulator control pin (On chip Emulator is used,this pin should be High. Not used,it should be Low)
11	WDTOVF#/TDO	TDO/WDTOVF#	O/O	-	-	-	-	E20 Emulator control pin
12	VSS	VSS	I	-	-	-	-	Ground pin
13	MDE	MDE	I	Pd	-	-	-	Pins for setting the operating mode (Little Edian:MDE=Low)
14	VCL	VCL	I	-	-	-	-	Smoothing capacitor connection pin

Pin	Pin Name	Symbol	I/O	Pu/Pd	STBY	STOP	CEC STBY	Function
15	MD1	MD1	I	M3VPu	-	-	-	"Pins for setting the operating mode(Select the Boot Mode or User Boot Mode,Single Chip Mode) (Single Chip Mode:MD0=High,MD1=High)/E20 Emulator control pin"
16	MD0	MD0	I	M3VPu	-	-	-	
17	P86	CEC POWER2	O		L	L	H	CEC standby power control (for CEC Standby Mode 3)
18	P85	Tx EN	O		L	L	L	Front HDMI (AD8195) control
19	RES#	RESET	I		-	-	-	Reset signal input pin
20	XTAL	XTAL	I		-	-	-	Pins for a crystal resonator (Xin=12MHz × 8)
21	VSS	VSS	-		-	-	-	Ground pin
22	EXTAL	EXTAL	-		-	-	-	Pins for a crystal resonator (Xin=12MHz × 8)
23	VCC	VCC	-		-	-	-	Power supply pin
24	NMI	NMI	I	M3VPu	-	-	-	Non-maskable interrupt request signal (Pull-up)
25	P34/IRQ4-A/PO12/TIOCA1	BDOWN	I		I	I	I	Detect power down
26	P33/IRQ3-A/PO11/TIOCC0/TIOCD0/TCLKB-A	DAC.PLD ERR	I		L	L	L	Detect DAC/PLD error (from Audio PLD and DAC)
27	P32/IRQ2-A/PO10/TIOCC0/TCLKA-A	DA POWER2	O		L	L	L	Digital audio power supply (D1.0V) control pin
28	P31/IRQ1-A/PO9/TIOCA0/TIOCB0	NC	O		L	L	L	NC
29	P30/IRQ0-A/PO8/TIOCA0	RC IN	I		I	I	I	Remote input
30	P27/PO7/TIOCA5/TIOCB5/SCK1	Hi-B RL	O		L	L	L	HIGH-B relay control pin
31	P26/PO6/TIOCA5/TMO1/TxD1	PSCL	I/O	C	O/L	L	L	HDMI I2C (MN864788/788A) control pin
32	P25/PO5/TIOCA4/TMC1/RxD1	PSDA	I/O	C	O/L	L	L	HDMI (MN864788/788A) control pin
33	P24/PO4/TIOCA4/TIOCB4/TMR1	TU RST	O	SW3VPu	L	L	L	TUNER control
34	P23/PO3/TIOCC3/TIOCD3	E RESET	O(ODR)	N3VPu	L	L	L	Ethernet(CY920) reset control pin (Set to NMOS open-drain output)
35	P22/PO2/TIOCC3/TMO0/SCK0	E SPI CLK	O	N3VPu	L	L	L	Ethernet(CY920) control pin
36	P21/PO1/TIOCA3/TMC0/RxD0	E SPI MIEO	I	N3VPu	I	L	I	Ethernet(CY920) control pin
37	P20/PO0/TIOCA3/TIOCB3/TMR10/TxD0	E SPI MOEI	O	N3VPu	L	L	L	Ethernet(CY920) control pin
38	P17/IRQ7-B/TCLKD-B/TxD3/SCL0/ADTRG1#	TU SCLK	O		L	L	L	TUNER control
39	PLLVCC	PLLVCC	-		-	-	-	Power supply pin for the PLL circuit
40	P16/IRQ6-B/TCLKC-B/RxD3/SDA0	TU SDIO	I_O		L	L	L	TUNER control
41	PLLVSS	PLLVSS	-		-	-	-	Ground pin for the PLL circuit
42	P15/IRQ5-B/TCLKB-B/SCK3/SCL1	EEPROM SCL	O	M3VPu	I	I	I	EEPROM control pin
43	P14/IRQ4-B/TCLKA-B/SDA1	EEPROM SDA	I_O	M3VPu	I	I	I	EEPROM control pin
44	P13/IRQ3-B/TxD2/ADTRG0#	ADV7623 SPI MO	O		L	L	L	HDMI transceiver w/ GUI(ADV7623) control pin (for GUI)
45	P12/IRQ2-B/RxD2	ADV7623 SPI MI	I		L	L	L	HDMI transceiver w/ GUI(ADV7623) control pin (for GUI)
46	P11/IRQ1-B/SCK2	ADV7623 SPI CLK	O		L	L	L	HDMI transceiver w/ GUI(ADV7623) control pin (for GUI)
47	P10/IRQ0-B	ADV7623 SPI CS	O		L	L	L	HDMI transceiver w/ GUI(ADV7623) control pin (for GUI)
48	P37/PO15/TIOCA2/TIOCB2/TCLKD-A	HSCL (400k)	O	CE-C3VPu	L	L	L	HDMI transceiver w/ GUI(ADV7623) control pin (for HDMI)

Pin	Pin Name	Symbol	I/O	Pu/Pd	STBY	STOP	CEC STBY	Function
49	P36/PO14/TIOCA2	HSDA (400k)	I_O	CE-C3VPu	L	L	L	HDMI transceiver w/ GUI(ADV7623) control pin (for HDMI)
50	P35/PO13/TIOCA1/TIOCB1/TCLKC-A	MN864788 RST	O	SW3VPu	L	L	L	HDMI Tx (MN864788) reset control pin
51	P84	CEC_OUT	O		L	L	-	CEC-D control pin
52	P57/WAIT#/TRDATA3	MN864788A RST	O	SW3VPu	L	L	L	HDMI Rx (MN864788A) reset control pin
53	P56/TRDATA2	E POWER1	O		L	L	L	Ethernet(CY920) power supply control(for 3.3V)
54	P55/TRDATA1	ADV7623 RST	O	SW3VPu	L	L	L	HDMI transceiver w/ GUI(ADV7623) reset control pin
55	P54/TRDATA0	E POWER2	O		L	L	L	Ethernet(CY920) power supply control(for 2.5V)
56	P83	E POWER3	O		L	L	L	Ethernet(CY920) power supply control(for 1.8V)
57	VSS	VSS	-		-	-	-	Ground pin
58	P82/TRCLK	FL CE	O		L	L	L	FL display control pin
59	VCC	VCC	-		-	-	-	Power supply pin
60	P81/TRSYNC	FL RST	O		L	L	L	FL display control pin
61	P80	E POWER4	O		L	L	L	Ethernet(CY920) power supply control(for 1.2V)
62	BCLK/P53(入力専用)	DSP BSY	I		I	I	I	DSP BUSY signal input
63	P52/RD#	MN864788A HINT	I		I	I	I	HDMI Rx (MN864788A) interrupt signal det
64	P51/WR1#/BC1#	NC	O		L	L	L	NC
65	P50/WR0#/WR#	HIN SELC	I	Pu	I	L	I	HDMI +5V selector (TC4051) control pin
66	P77	H5V DET	I		I	I	I	HDMI IN 5V detect signal pin
67	P76/IRQ14-A	TU GPO2_INT	I		L	L	L	TUNER control pin
68	P75	NC	O		L	L	L	NC
69	PC7/A23/CS4#-D/CS7#-D/TxD5	DSP MOSI	O	DA3VPu	L	L	L	DSP(CS49844A) control pin
70	PC6/A22/CS6#-D/RxD5	DSP MISO	I	DA3VPu	L	L	L	DSP(CS49844A) control pin
71	PC5/A21/CS5#-D/SCK5	DSPI CLK	O	DA3VPu	L	L	L	DSP(CS49844A) control pin
72	PC4/A20	DSP RST	O		L	L	L	DSP(CS49844A) reset control pin
73	PC3/A19	DSP FLAG0	I	Pd	L	L	L	DSP(CS49844A) interrupt signal input pin
74	VCC	VCC	-		-	-	-	Power supply pin.
75	PC2/A18	DSP ICS	O	DA3VPu	L	L	L	DSP(CS49844A) control pin
76	VSS	VSS	-		-	-	-	Ground pin
77	PC1/A17	WHITE LED(X1300(NA)/GREEN LED(X1300(AP/CH)/S720)	O		L	L	L	POWER LED control pin
78	PC0/A16	RED LED	O		L/H	L	H	POWER/STANDBY LED control pin
79	PB7/A15/PO31/TIOCA11/TIOCB11	H/P RL	O		L	L	L	Headphone relay control pin
80	PB6/A14/PO30/TIOCA11	FRONT RL	O		L	L	L	Speaker relay control pin
81	PB5/A13/PO29/TIOCA10/TIOCB10	DSP ROM WRITE	O		L	L	L	DSP ROM writing control(When writing,set to High)
82	PB4/A12/PO28/TIOCA10	TU_SEN	O		L	L	L	TUNER control pin
83	PB3/A11/PO27/TIOCC9/TIOCD9	C/S RL	O		L	L	L	Speaker relay control pin
84	PB2/A10/PO26/TIOCC9	SB RL	O		L	L	L	Speaker relay control pin
85	PB1/A9/PO25/TIOCA9/TIOCB9	D5V POWER	O		L	L	H	Digital 5V power supply control pin(3.3V and 1.8V generate from 5V)
86	P74/ADTRG3#	DIR CE	O		L	L	L	DIR (PCM9211) control pin
87	P73	DIR DIN	O		L	L	L	DIR (PCM9211) control pin
88	P72	DIR DOUT	I	DA3VPu	I	I	I	DIR (PCM9211) control pin
89	P71/CS4#-C/CS5#-C/CS6#-C/CS7#-C	DIR CLK	O		L	L	L	DIR (PCM9211) control pin

Pin	Pin Name	Symbol	I/O	Pu/Pd	STBY	STOP	CEC STBY	Function
90	P70/CS3#-B/ ADTRG2#	DIR RST	O		L	L	L	DIR (PCM9211) control pin
91	VCC	VCC	-		-	-	-	Power supply pin.
92	PB0/A8/PO24/ TIOCA9	7623 ROM HOLD	O		L	L	L	Flash ROM for GUI control pin
93	VSS	VSS	-		-	-	-	Ground pin.
94	PA7/A7/PO23/ TIOCA8/TIOCB8/ TCLKH	VEXP OE	O		L	L	L	Expander (MC14094) control pin
95	PA6/A6/PO22/ TIOCA8	VSEL A	I		I	I	I	Master volume (Rotary encoder) signal input pin
96	PA5/A5/PO21/ TIOCA7/TIOCB7/ TCLKG	VSEL B	I		I	I	I	Master volume (Rotary encoder) signal input pin
97	PA4/A4/PO20/ TIOCA7	ZVOL DATA(X1300(NA)/ NC(X1300(AP/CH)/ S720)	O		L	L	L	ZONE volume(BD3812) control pin
98	PA3/A3/PO19/ TIOCC6/TIOCD6/ TCLKF	ZVOL CLK(X1300(NA)/ NC(X1300(AP/CH)/ S720)	O		L	L	L	ZONE volume(BD3812) control pin
99	PA2/A2/PO18/ TIOCC6/TCLKF	PRE Z2 MUTE(X1300(NA)/ NC(X1300(AP/CH)/ S720)	O		L	L	L	ZONE volume(BD3812) control pin
100	PA1/A1/PO17/ TIOCA6/TIOCB6	CLK MUTE	O		L	L	L	Audio PLD (5M80ZT100C5N) control pin(for MUTE CLK.When mute is active,set to High)
101	PA0/A0/BC0#/ PO16/TIOCA6	PRE MUTE	O		L	L	L	MUTE for preout control pin
102	PE7/IRQ7-A/D15	DSP FLAG3	I	Pd	L	L	L	DSP(CS49844A) interrupt signal input pin
103	PE6/IRQ6-A/D14	MN864788 HINT	I		I	I	I	HDMI Tx (MN864788) interrupt signal input pin
104	PE5/IRQ5-A/D13	MN864788 HAIINT	I		I	I	I	HDMI Tx (MN864788) interrupt signal input pin(for Audio)
105	PE4/D12	ISEL A	I		I	I	I	Input selector (Rotary encoder) signal input pin
106	PE3/D11	ISEL B	I		I	I	I	Input selector (Rotary encoder) signal input pin
107	PE2/D10	VOL CLK	O		L	L	L	Input selector w/ Volume(NJU72340A) control pin
108	PE1/D9	VOL DATA	O		L	L	L	Input selector w/ Vvolume(NJU72340A) control pin
109	PE0/D8	PLD WRITE	O		L	L	L	PLD writing control(To switch the PLD and JTAG I/ F.When writing,set to Low)
110	PD7/D7	JTAG TDO	I		L	L	L	JTAG I/F for PLD writing
111	PD6/D6	JTAG TMS/APLD CS	O/O		L	L	L	JTAG I/F for PLD writing/Audio PLD (5M80ZT100C5N) control pin
112	PD5/D5	JTAG TDI/APLD DATA/DAC DATA	O/O		L	L	L	JTAG I/F for PLD writing/Audio PLD (5M80ZT100C5N) control pin/DAC (PCM1690) control pin
113	PD4/D4	JTAG TCK/APLD CLK/DAC CLK	O/O		L	L	L	JTAG I/F for PLD writing/Audio PLD (5M80ZT100C5N) control pin/DAC (PCM1690) control pin
114	P64/CS4#-B	VEXP STB	O		L	L	L	Expander (MC14094) control pin
115	P63/CS3#-A/CS7#-A	THERMAL A	I	SW3VPu	I	L	I	Protection detect signal input pin
116	P62/CS2#-A/CS6#-A	E SPI CS	O	N3VPu	L	L	L	Ethernet(CY920) control pin
117	P61/CS1#-A/CS2#- B/CS5#-A/CS6#-B/ CS7#-B	DAC MS	O		L	L	L	DAC (PCM1690) control pin
118	P60/CS0#-A/CS4#-A/ CS5#-B	DAC RST	O		L	L	L	DAC (PCM1690) control pin
119	PD3/D3	VEXP CLK	O		L	L	L	Expander (MC14094) control pin
120	PD2/D2	VEXP DATA	O		L	L	L	Expander (MC14094) control pin
121	PD1/D1	FL CLK	O		L	L	L	FL display control pin
122	PD0/D0	FL DATA	O		L	L	L	FL display control pin
123	P97/AN15	DA POWER	O		L	L	L	Digital audio power supply (DA3.3V,DA1.2V) control pin

Pin	Pin Name	Symbol	I/O	Pu/Pd	STBY	STOP	CEC STBY	Function
124	P96/AN14	CEC POWER	O		L	L	-	CEC standby power supply control(CEC5V,CEC3.3V,CEC1.8V)
125	P95/AN13	DV POWER1	O		L	L	-	Digital video power supply (DV5V,DV3.3V) control pin
126	P94/AN12	THERMAL B	I	SW3VPu	I	L	I	Protection detect signal input pin
127	P93/AN11	MAIN POWER	O		L	L	L	Power supply control pin
128	P92/AN10	CPU POWER	O		L	L	L	CPU power supply control pin
129	P91/AN9	AMPSIGDET	I		I	L	I	Signal level monitor pin (AD converter)
130	VSS	VSS	-		-	-	-	Ground pin
131	P90/AN8	MODE	I		I	I	I	Region setting pin
132	VCC	VCC	-		-	-	-	Power supply pin
133	P47/IRQ15-B/AN7	DC DET/ASO	I		I	I	I	Protection detect signal input pin (for DC and ASO) (A/D converter)
134	P46/IRQ14-B/AN6	H/P DET / MIC DET	I		I	I	I	Headphone insert detect pin/Microphone insert detect pin (A/D converter)
135	P45/IRQ13-B/AN5	KEY3	I	SW3VPu	I	I	I	Key control signalinput pin (When standby mode,set to inturrupt)
136	P44/IRQ12-B/AN4	KEY2	I	SW3VPu	I	I	I	Key control signalinput pin (When standby mode,set to inturrupt)
137	P43/IRQ11-B/AN3	KEY1	I	SW3VPu	I	I	I	Key control signalinput pin (When standby mode,set to inturrupt)
138	P42/IRQ10-B/AN2	E SPI REQ	I	Pd	I	L	I	Ethernet(CY920) control pin
139	P41/IRQ9-B/AN1	CURRENT DET	I		I	L	I	Current level monitor pin (A/D converter)
140	AVSS	AVSS	-		-	-	-	Ground pin
141	P40/IRQ8-B/AN0	CEC_IN	I	SW3VPu	I	I	I	CEC-D control pin
142	VREF	VREF	-		-	-	-	Reference power supply pin
143	AVCC	AVCC	-		-	-	-	Analog power supply pin
144	P05/IRQ13-A/ TMO3/RxD4/TCK	TCK/RXD MITSUBI- SHI/NC(NORMRAL)	I/I/I	M3VPu	-/-/I	-/-/I	I	E20 Emulator control pin/Mitsubishi writer control pin/When Normal Operating Mode,set to input.

Caution in
servicing

Electrical

Mechanical

Repair Information

Updating

MC74HC4094ADR2G (DIGITAL_MCU : IC753)

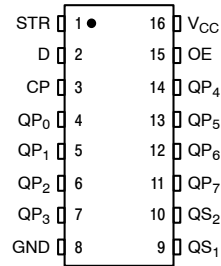

Logic Diagram

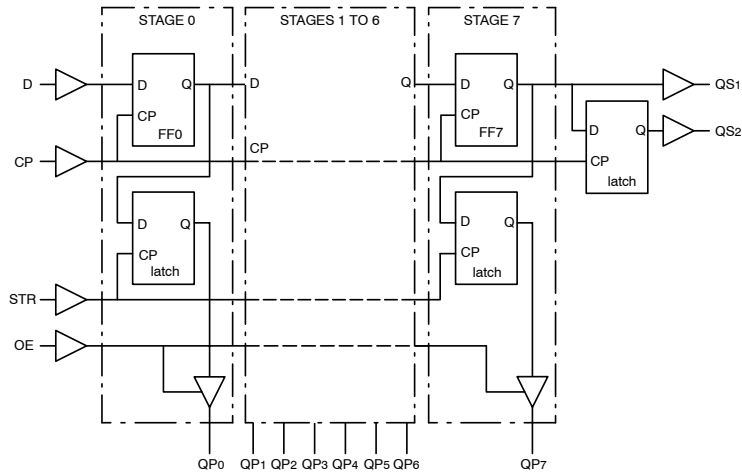

R1EX24128BSASOI (DIGITAL_MCU : IC752)

8-pin SOP/8-pin TSSOP

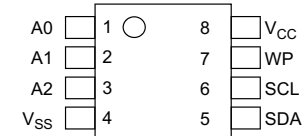

(Top view)

Block diagram

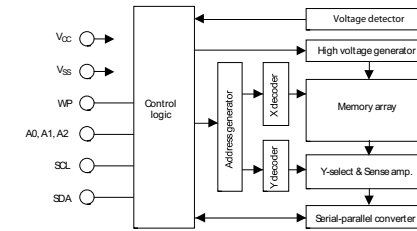

Pin Function Descriptions

Pin name	Function
A0 to A2	Device address
SCL	Serial clock input
SDA	Serial data input/output
WP	Write protect
Vcc	Power supply
Vss	Ground

SN74LVC244APWR (DIGITAL_MCU LEVEL CHG : IC761) (DIGITAL_DSP : IC783)

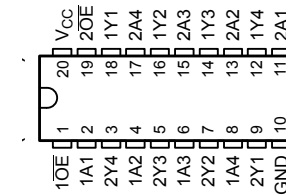

Block diagram

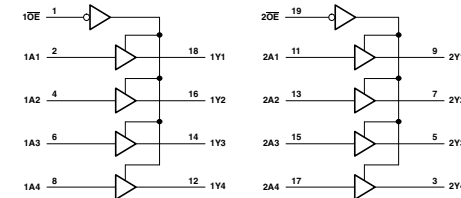

PCM9211PTR (DIGITAL_DIR : IC772)

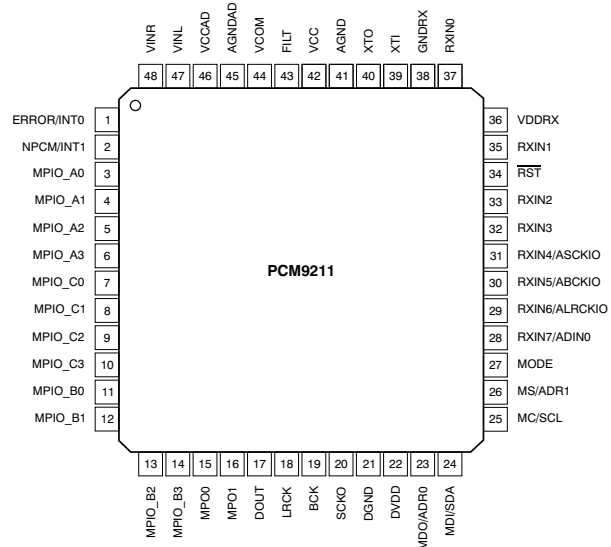

PIN Functions

PIN				DESCRIPTION
NO.	NAME	I/O	5-V TOLERANT	
1	ERROR/INT0	O	No	DIR Error detection output / Interrupt0 output
2	NPCM/INT1	O	No	DIR Non-PCM detection output / Interrupt1 output
3	MPIO_A0	I/O	Yes	Multipurpose I/O, Group A(1)
4	MPIO_A1	I/O	Yes	Multipurpose I/O, Group A(1)
5	MPIO_A2	I/O	Yes	Multipurpose I/O, Group A(1)
6	MPIO_A3	I/O	Yes	Multipurpose I/O, Group A(1)
7	MPIO_C0	I/O	Yes	Multipurpose I/O, Group C(1)
8	MPIO_C1	I/O	Yes	Multipurpose I/O, Group C(1)
9	MPIO_C2	I/O	Yes	Multipurpose I/O, Group C(1)
10	MPIO_C3	I/O	Yes	Multipurpose I/O, Group C(1)
11	MPIO_B0	I/O	Yes	Multipurpose I/O, Group B(1)
12	MPIO_B1	I/O	Yes	Multipurpose I/O, Group B(1)
13	MPIO_B2	I/O	Yes	Multipurpose I/O, Group B(1)
14	MPIO_B3	I/O	Yes	Multipurpose I/O, Group B(1)
15	MPO0	O	No	Multipurpose output 0
16	MPO1	O	No	Multipurpose output 1
17	DOUT	O	No	Main output port, serial digital audio data output
18	LRCK	O	No	Main output port, LR clock output
19	BCK	O	No	Main output port, Bit clock output
20	SCKO	O	No	Main output port, System clock output
21	DGND	-	-	Ground, for digital

PIN				DESCRIPTION
NO.	NAME	I/O	5-V TOLERANT	
22	DVDD	-	-	Power supply, 3.3 V (typ.), for digital
23	MDO/ADR0	I/O	Yes	Software control I/F, SPI data output / I2C slave address setting0(2)
24	MDI/SDA	I/O	Yes	Software control I/F, SPI data input / I2C data input/output(2) (3)
25	MC/SCL	I	Yes	Software control I/F, SPI clock input / I2C clock input(2)
26	MS/ADR1	I	Yes	Software control I/F, SPI chip select / I2C slave address setting1(2)
27	MODE	I	No	Control mode setting. (see the Serial Control Mode section, Control Mode Pin Setting)
28	RXIN7/ADIN0	I	Yes	Biphase signal, input 7 / AUXIN0, serial audio data input(2)
29	RXIN6/ALRCKIO	I	Yes	Biphase signal, input 6 / AUXIN0, LR clock input(2)
30	RXIN5/ABCKIO	I	Yes	Biphase signal, input 5 / AUXIN0, bit clock input(2)
31	RXIN4/ASCKIO	I	Yes	Biphase signal, input 4 / AUXIN0, system clock input(2)
32	RXIN3	I	Yes	Biphase signal, input 3(2)
33	RXIN2	I	Yes	Biphase signal, input 2(2)
34	RST	I	Yes	Reset Input, active low(2) (4)
35	RXIN1	I	Yes	Biphase signal, input 1, built-in coaxial amplifier
36	VDDRX	-	-	Power supply, 3.3 V (typ.), for RXIN0 and RXIN1.
37	RXIN0	I	Yes	Biphase signal, input 0, built-in coaxial amplifier
38	GNDRX	-	-	Ground, for RXIN
39	XTI	I	No	Oscillation circuit input for crystal resonator or external XTI clock source input(5)
40	XT0	O	No	Oscillation circuit output for crystal resonator
41	AGND	-	-	Ground, for PLL analog
42	VCC	-	-	Power supply, 3.3 V (typ.), for PLL analog
43	FILT	O	No	External PLL loop filter connection terminal; must connect recommended filter
44	VCOM	O	No	ADC common voltage output; must connect external decoupling capacitor
45	AGNDAD	-	-	Ground, for ADC analog
46	VCCAD	-	-	Power supply, 5.0 V (typ.), for ADC analog
47	VINL	I	No	ADC analog voltage input, left channel
48	VINR	I	No	ADC analog voltage input, right channel

- (1) Schmitt trigger input
- (2) Schmitt trigger input
- (3) Open-drain configuration in I2C mode
- (4) Onboard pull-down resistor (50 k Ω , typical)
- (5) CMOS Schmitt trigger input

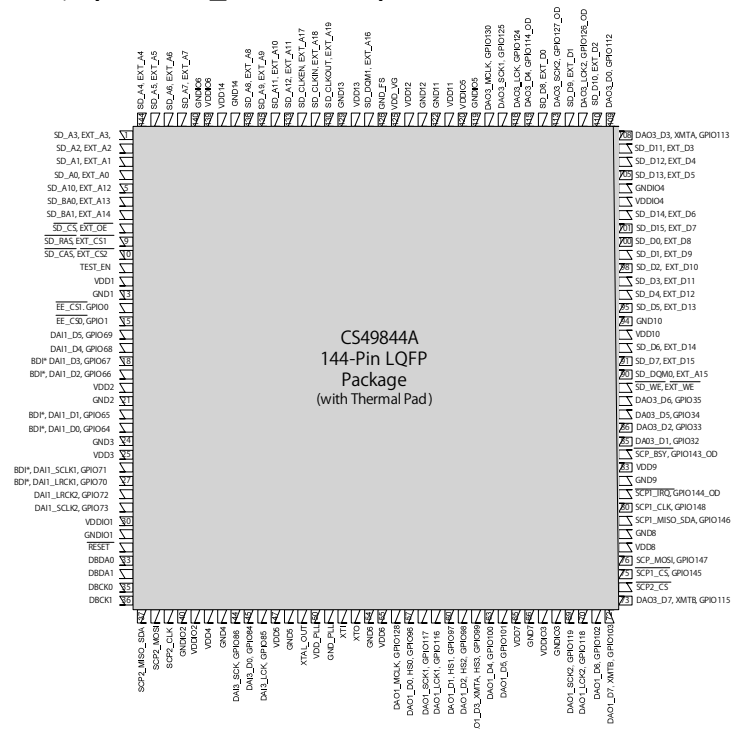
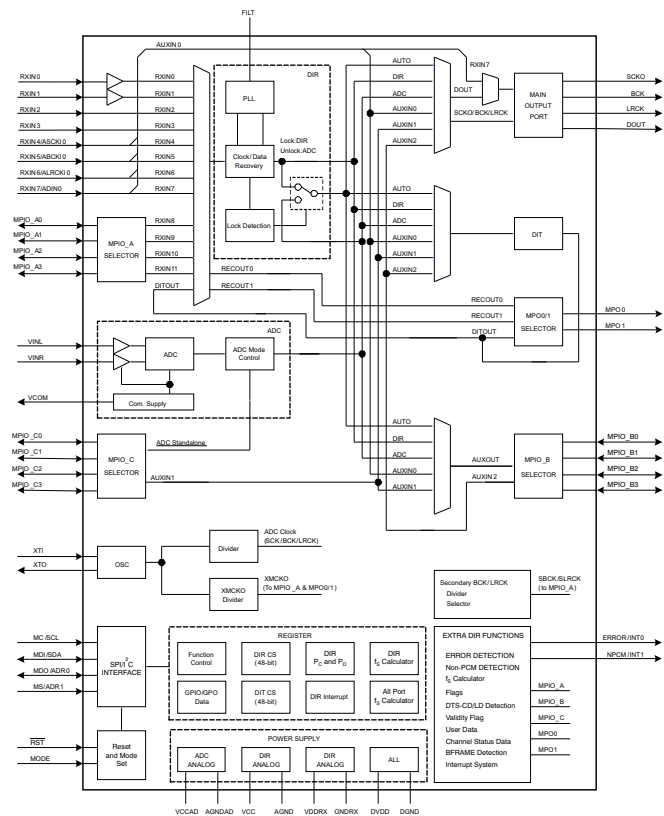

CS49844A
144-Pin LQFP
Package
(with Thermal Pad)

Caution in Servicing

Electrical

Mechanical

Repair Information

Updating

MX25L6406EM2I-12G (DIGITAL_DSP : IC782)

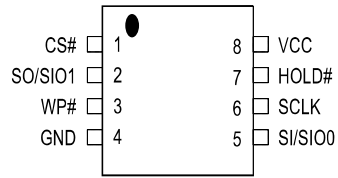

Block diagram

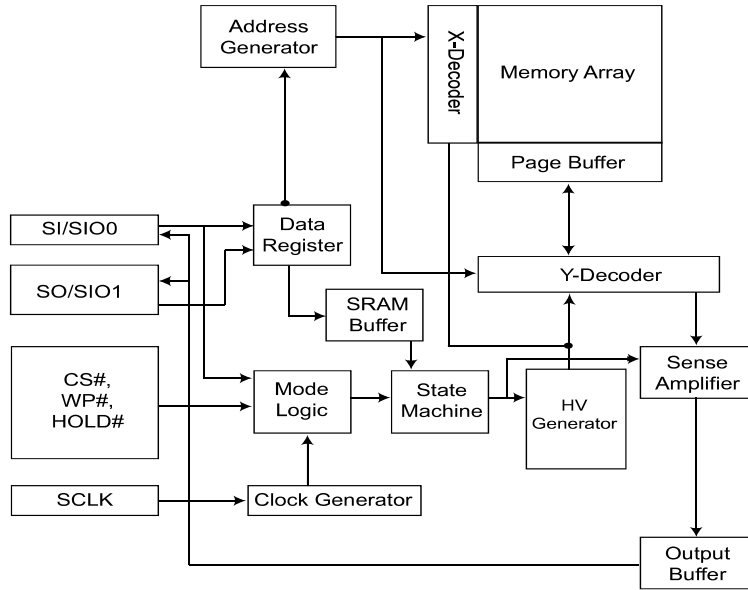

M12L64164A-5TG2Y (DIGITAL_DSP : IC784)

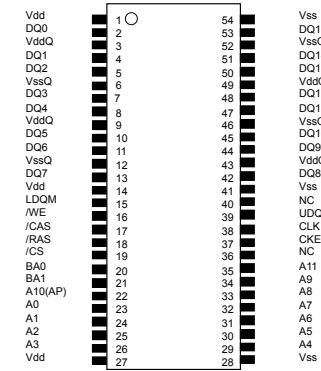

- CLK : Master Clock
- CKE : Clock Enable
- /CS : Chip Select
- /RAS : Row Address Strobe
- /CAS : Column Address Strobe
- /WE : Write Enable
- DQ0-15 : Data I/O
- U,LDQM : Output Disable / Write Mask
- A0-11 : Address Input
- BA0,1 : Bank Address
- Vdd : Power Supply
- VddQ : Power Supply for Output
- Vss : Ground
- VssQ : Ground for Output

Block diagram

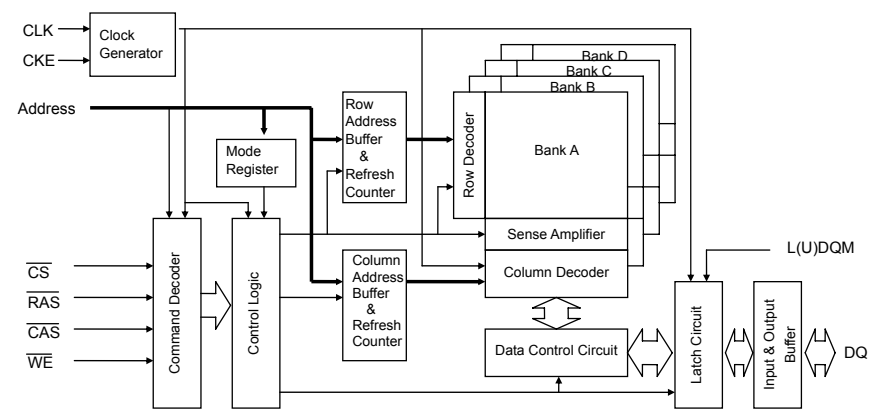

Caution in servicing

Electrical

Mechanical

Repair Information

Updating

PCM1690DCAR (DIGITAL_MAIN DAC : IC791)

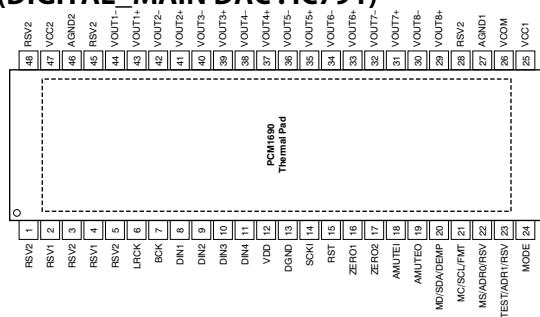

PCM1690 Pin Function

TERMINAL NAME	PIN	I/O	PULL-DOWN	5-V TOLERANT	DESCRIPTION
RSV2	1	—	—	—	Reserved, tied to analog ground
RSV1	2	—	—	—	Reserved, left open
RSV2	3	—	—	—	Reserved, tied to analog ground
RSV1	4	—	—	—	Reserved, left open
RSV2	5	—	—	—	Reserved, tied to analog ground
LRCK	6	I	Yes	No	Audio data word clock input
BCK	7	I	Yes	No	Audio data bit clock input
DIN1	8	I	No	No	Audio data input for DAC1 and DAC2
DIN2	9	I	No	No	Audio data input for DAC3 and DAC4
DIN3	10	I	No	No	Audio data input for DAC5 and DAC6
DIN4	11	I	No	No	Audio data input for DAC7 and DAC8
VDD	12	—	—	—	Digital power supply, +3.3 V
DGND	13	—	—	—	Digital ground
SCK1	14	I	No	Yes	System clock input
RST	15	I	Yes	Yes	Reset and power-down control input with active low
ZERO1	16	O	No	No	Zero detect flag output 1
ZERO2	17	O	No	No	Zero detect flag output 2
AMUTEI	18	I	No	Yes	Analog mute control input with active low
AMUTEO	19	O	No	Yes	Analog mute status output(1) with active low
MD/SDA/DEMP	20	I/O	No	Yes	Input data for SPI, data for I2C(1), de-emphasis control for hardware control mode
MC/SCL/FMT	21	I	No	Yes	Clock for SPI, clock for I2C, format select for hardware control mode
MS/ADR0/RSV	22	I	Yes	Yes	Chip Select for SPI, address select 0 for I2C, reserve (set low) for hardware control mode
TEST/ADR1/RSV	23	I/O	No	Yes	Test (factory use, left open) for SPI, address select 1 for I2C, reserve (set low) for hardware control mode
MODE	24	I	No	No	Control port mode selection. Tied to VDD: SPI, left open: H/W mode, tied to DGND: I2C
VCC1	25	—	—	—	Analog power supply 1, +5 V
VCOM	26	—	—	—	Voltage common decoupling
AGND1	27	—	—	—	Analog ground 1
RSV2	28	—	—	—	Reserved, tied to analog ground

TERMINAL NAME	PIN	I/O	PULL-DOWN	5-V TOLERANT	DESCRIPTION
VOUT8+	29	O	No	No	Positive analog output from DAC8
VOUT8-	30	O	No	No	Negative analog output from DAC8
VOUT7+	31	O	No	No	Positive analog output from DAC7
VOUT7-	32	O	No	No	Negative analog output from DAC7
VOUT6+	33	O	No	No	Positive analog output from DAC6
VOUT6-	34	O	No	No	Negative analog output from DAC6
VOUT5+	35	O	No	No	Positive analog output from DAC5
VOUT5-	36	O	No	No	Negative analog output from DAC5
VOUT4+	37	O	No	No	Positive analog output from DAC4
VOUT4-	38	O	No	No	Negative analog output from DAC4
VOUT3+	39	O	No	No	Positive analog output from DAC3
VOUT3-	40	O	No	No	Negative analog output from DAC3
VOUT2+	41	O	No	No	Positive analog output from DAC2
VOUT2-	42	O	No	No	Negative analog output from DAC2
VOUT1+	43	O	No	No	Positive analog output from DAC1
VOUT1-	44	O	No	No	Negative analog output from DAC1
RSV2	45	—	—	—	Reserved, tied to analog ground
AGND2	46	—	—	—	Analog ground 2
VCC2	47	—	—	—	Analog power supply 2, +5 V
RSV2	48	—	—	—	Reserved, tied to analog ground

(1) Open-drain configuration in out mode.

Caution in servicing

Electrical

Mechanical

Repair Information

Updating

BD82065FVJ-E2 (DIGITAL_NETWORK : IC801)

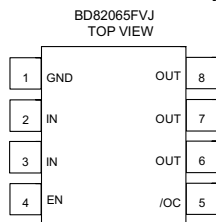

Block diagram

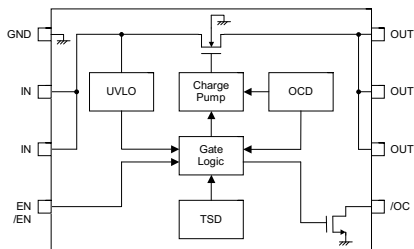

SN74LVC827APWR (DIGITAL_NETWORK : IC804)

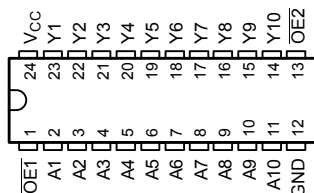

Block diagram

FUNCTION TABLE

INPUTS			OUTPUT
OE1	OE2	A	Y
L	L	L	L
L	L	H	H
H	X	X	Z
X	H	X	Z

LOGIC DIAGRAM (POSITIVE LOGIC)

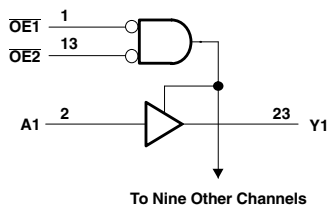

To Nine Other Channels

PCM510PWR (DIGITAL_NETWORK : IC805)

PCM510x (top view)

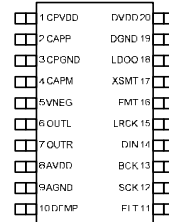
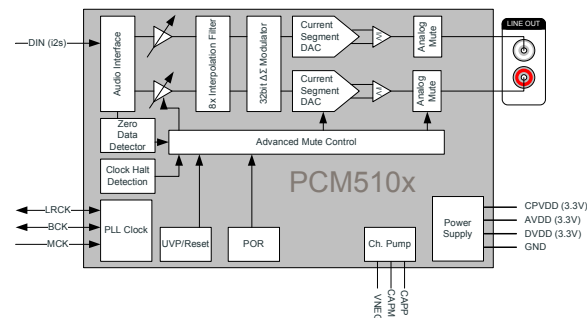

Table 2. TERMINAL FUNCTIONS, PCM510x

TERMINAL NAME	NO.	I/O	DESCRIPTION
CPVDD	1	-	Charge pump power supply, 3.3V
CAPP	2	O	Charge pump flying capacitor terminal for positive rail
CPGND	3	-	Charge pump ground
CAPM	4	O	Charge pump flying capacitor terminal for negative rail
VNEG	5	O	Negative charge pump rail terminal for decoupling, -3.3V
OUTL	6	O	Analog output from DAC left channel
OUTR	7	O	Analog output from DAC right channel
AVDD	8	-	Analog power supply, 3.3V
AGND	9	-	Analog ground
DEMP	10	I	De-emphasis control for 44.1kHz sampling rate ⁽¹⁾ : Off (Low) / On (High)
FLT	11	I	Filter select : Normal latency (Low) / Low latency (High)
SCK	12	I	System clock input
BCK	13	I	Audio data bit clock input
DIN	14	I	Audio data input
LRCK	15	I	Audio data word clock input
FMT	16	I	Audio format selection : I ² S (Low) / Left justified (High)
XSMT	17	I	Soft mute control : Soft mute (Low) / soft un-mute (High)
LDOO	18	-	Internal logic supply rail terminal for decoupling
DGND	19	-	Digital ground
DVDD	20	-	Digital power supply, 3.3V

(1) Failsafe LVCMOS Schmitt trigger input

Block diagram



AD8195 (F-HDMI : IC811)

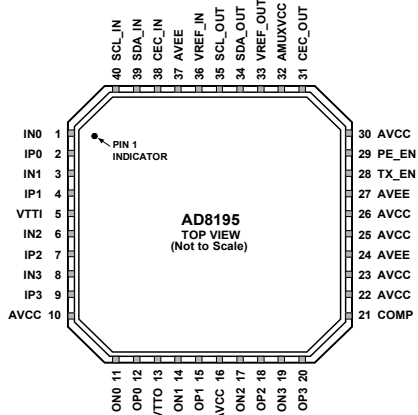

NOTES
 1. THE AD8195 LFCSP HAS AN EXPOSED PAD ON THE UNDERSIDE OF THE PACKAGE THAT AIDS IN HEAT DISSIPATION. THE PAD MUST BE ELECTRICALLY CONNECTED TO THE AVEE SUPPLY PLANE IN ORDER TO MEET THERMAL SPECIFICATIONS.

AD8195 Terminal Functions

Pin No.	Mnemonic	Type ¹	Description
1	IN0	HS I	High Speed Input Complement.
2	IP0	HS I	High Speed Input.
3	IN1	HS I	High Speed Input Complement.
4	IP1	HS I	High Speed Input.
5	VTT1	Power	Input Termination Supply. Nominally connected to AVCC.
6	IN2	HS I	High Speed Input Complement.
7	IP2	HS I	High Speed Input.
8	IN3	HS I	High Speed Input Complement.
9	IP3	HS I	High Speed Input.
10, 16, 22, 23, 25, 26, 30	AVCC	Power	Positive Analog Supply. 3.3 V nominal.
11	ON0	HS O	High Speed Output Complement.
12	OP0	HS O	High Speed Output.
13	VTTO	Power	Output Termination Supply. Nominally connected to AVCC.
14	ON1	HS O	High Speed Output Complement.
15	OP1	HS O	High Speed Output.
17	ON2	HS O	High Speed Output Complement.
18	OP2	HS O	High Speed Output.
19	ON3	HS O	High Speed Output Complement.
20	OP3	HS O	High Speed Output.
21	COMP	Control	Power-On Compensation Pin. Bypass to ground through a 10 μF capacitor.
24, 27, 37, Exposed Pad	AVEE	Power	Negative Analog Supply. 0 V nominal.
28	TX_EN	Control	High Speed Output Enable Parallel Interface.
29	PE_EN	Control	High Speed Preemphasis Enable Parallel Interface.
31	CEC_OUT	LS I/O	CEC Output Side.
32	AMUXVCC	Power	Positive Auxiliary Buffer Supply. 5 V nominal.
33	VREF_OUT	Reference	DDC Output Side Pull-Up Reference Voltage.
34	SDA_OUT	LS I/O	DDC Output Side Data Line Input/Output.
35	SCL_OUT	LS I/O	DDC Output Side Clock Line Input/Output.
36	VREF_IN	Reference	DDC Input Side Pull-Up Reference Voltage.
38	CEC_IN	LS I/O	CEC Input Side.
39	SDA_IN	LS I/O	DDC Input Side Data Line.
40	SCL_IN	LS I/O	DDC Input Side Clock Line.

¹ HS = high speed, LS = low speed, I = input, and O = output.

NJU72340AFH3 (DIGITAL_ANALOG : IC821)

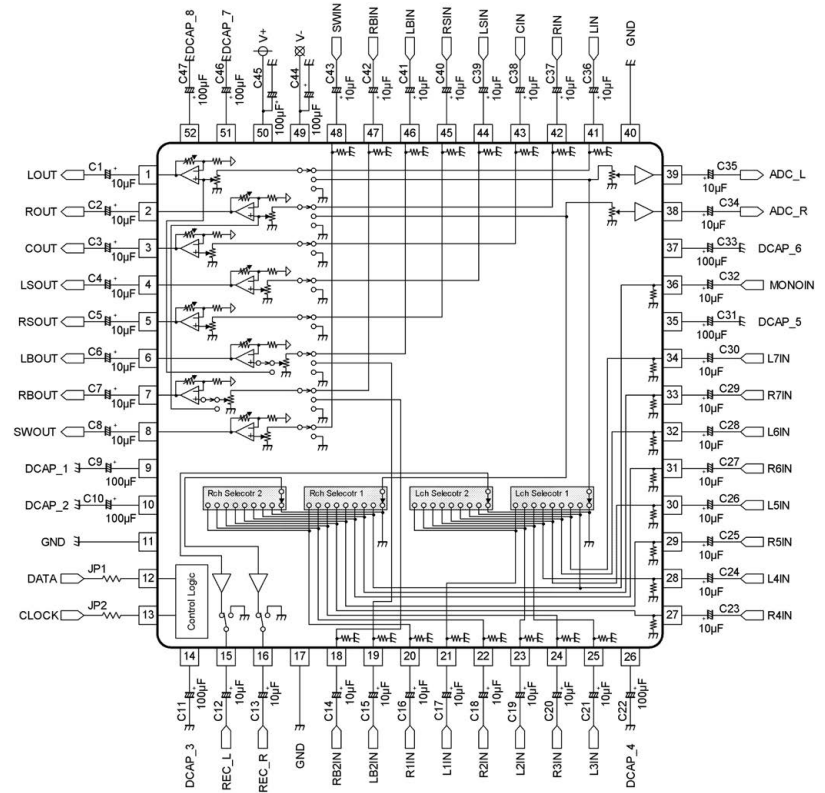

NJU72340A Terminal Functions

Pin No.	SYMBOL	Pin No.	SYMBOL	Pin No.	SYMBOL	Pin No.	SYMBOL
1	LOUT	14	DCAP_3	27	R4IN	40	GND
2	ROUT	15	REC_R	28	L4IN	41	LIN
3	COUT	16	REG_L	29	R5IN	42	RIN
4	LOUT	17	GND	30	L5IN	43	CIN
5	ROUT	18	RB2IN	31	RGIN	44	LSIN
6	LBOUT	19	LB2IN	32	LGIN	45	RSIN
7	RBOUT	20	RI1IN	33	R7IN	46	LBIN
8	SWOUT	21	LI1IN	34	L7IN	47	RBIN
9	DCAP_1	22	R2IN	35	DCAP_5	48	SWIN
10	DCAP_2	23	L2IN	36	MONOIN	49	V-
11	GND	24	R3IN	37	DCAP_G	50	V+
12	DATA	25	L3IN	38	ADC_R	51	DCAP_7
13	CLOCK	26	DCAP_4	39	ADC_L	52	DCAP_8

Caution in servicing

Electrical

Mechanical

Repair Information

Updating

BD3812F (DIGITAL_ANALOG : IC851)

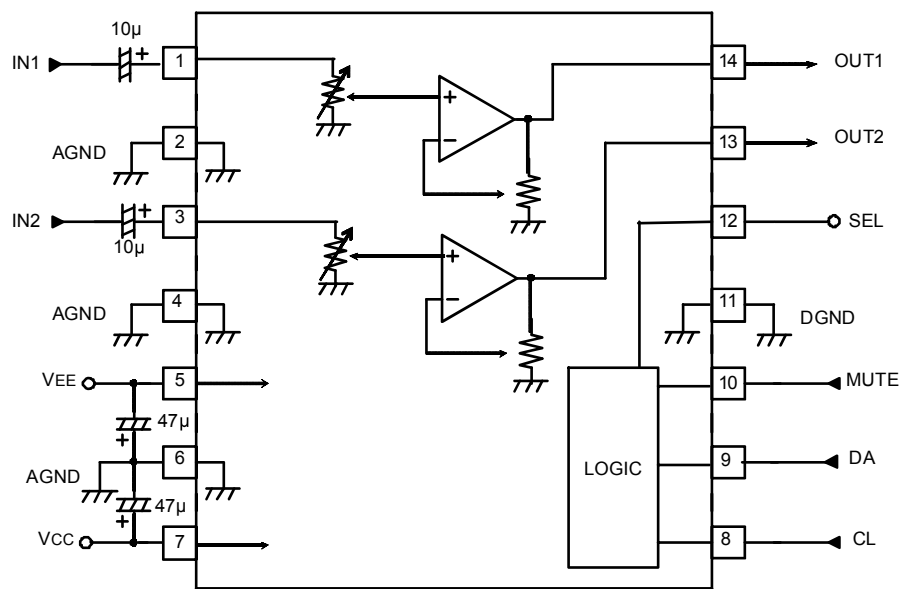

NJM2595MTE1 (DIGITAL_ANALOG : IC881)

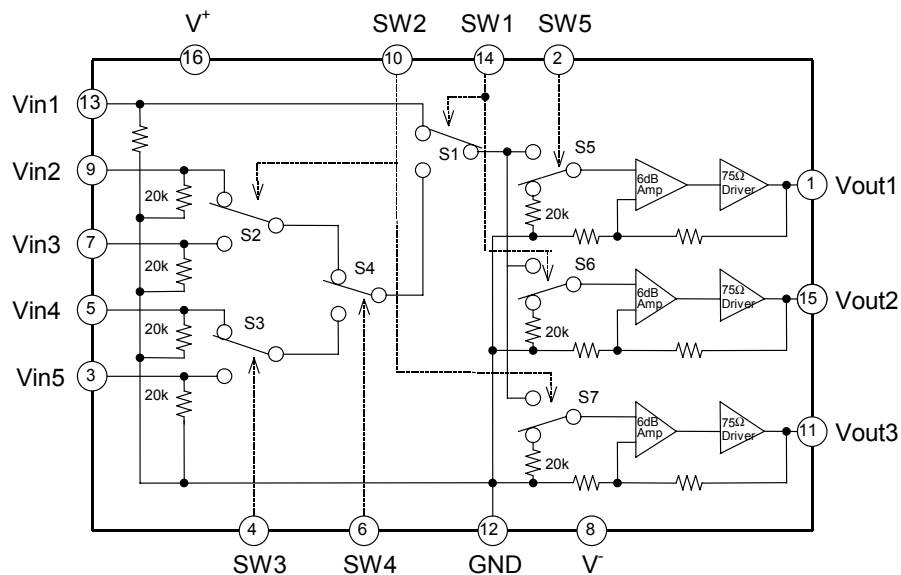

TOP268VG (SMPS : IC601)

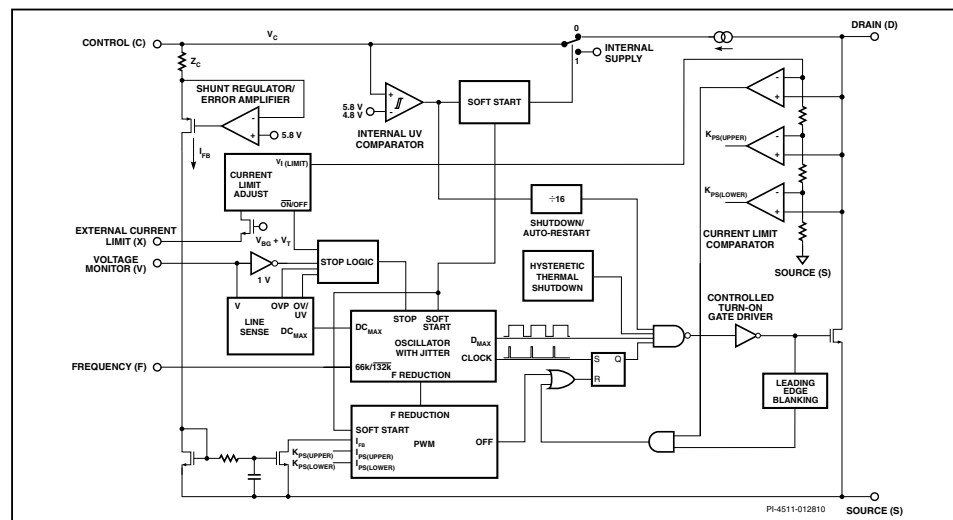

Figure 3. Functional Block Diagram.

Pin Functional Description

DRAIN (D) Pin:
High-voltage power MOSFET DRAIN pin. The internal start-up bias current is drawn from this pin through a switched high-voltage current source. Internal current limit sense point for drain current.

CONTROL (C) Pin:
Error amplifier and feedback current input pin for duty cycle control. Internal shunt regulator connection to provide internal bias current during normal operation. It is also used as the connection point for the supply bypass and auto-restart/compensation capacitor.

EXTERNAL CURRENT LIMIT (X) Pin:
Input pin for external current limit adjustment remote-ON/OFF and device reset. A connection to SOURCE pin disables all functions on this pin. This pin should not be left floating.

VOLTAGE MONITOR (V) Pin:
Input for OV, UV, line feed-forward with DC_{MAX} reduction, output overvoltage protection (OVP), remote-ON/OFF. A connection to the SOURCE pin disables all functions on this pin. This pin should not be left floating.

FREQUENCY (F) Pin :
Input pin for selecting switching frequency 132 kHz if connected to SOURCE pin and 66 kHz if connected to CONTROL pin. This pin should not be left floating.

SOURCE (S) Pin:
Output MOSFET source connection for high-voltage power return. Primary-side control circuit common and reference point.

NO CONNECTION (NC) Pin:
Internally not connected, floating potential pin.

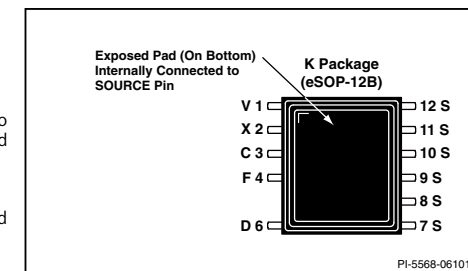
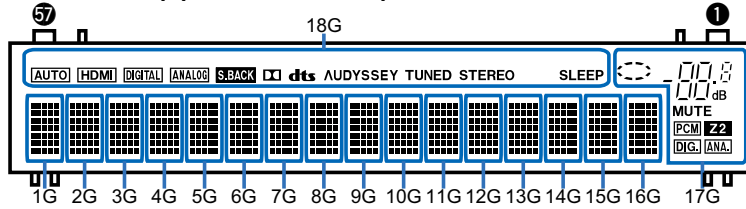

Figure 4. Pin Configuration (Top View).

2. FL DISPLAY

FLD (018BT021GINK) (FRONT : FL101)



PIN CONNECTION

CONNECTION	PIN NO.
F2	57
NP	56
NP	55
NP	54
LGND	53
PGND	52
VH	51

CONNECTION	PIN NO.
VDD	50
OSC	49
RESET	48
CS	47
CP	46
DA	45
TSA	44
TSB	43
NX	42
NX	41
NX	40
NX	39
NX	38
NX	37
NX	36
NX	35
NX	34
NX	33
NX	32
NX	31
NX	30
NX	29
NX	28
NX	27
NX	26
NX	25
NX	24
NX	23
NX	22
NX	21
NX	20
NX	19
NX	18
NX	17
NX	16
NX	15
NX	14
NX	13
NX	12
NX	11
NX	10
NX	9
18G	8
17G	7
Q17G	6
Q18G	5
NP	4
NP	3
NP	2
F1	1

NOTE

- 1) F1, F2 ----Filament
- 2) NP -----No pin
- 3) DL -----Datum Line
- 4) NX -----No extend pin
- 5) LGND ----Logic GND pin
- 6) PGND ----Power GND pin
- 7) VH -----High Voltage Supply pin
- 8) VDD -----Logic Voltage Supply pin
- 9) CP ----Shift Register Clock
- 10) DA ----Serial Data Input
- 11) TSA, B --Test pin
- 12) CS -----Chip Select Input pin
- 13) RESET --Reset Input
- 14) OSC ----Pin for self-oscillation
- 15) Solder composition is Sn-3Ag-0.5Cu.
- 16) 17G, 18G ---Grid
- 17) Q17G, Q18G ---Driver Output Port.
- 18) Field of vision is a minimum of 21.8° from the lower side.

DISASSEMBLY

Flowchart

1. FRONT PANEL ASSY
2. DIGITAL PCB
3. RADIATOR ASSY
4. SMPS PCB
5. REGULATOR PCB
6. TRANS POWER

EXPLODED VIEW

PACKING VIEW

Flowchart

- Remove each part following the flow below.
- Reassemble the removed parts in the reverse order.
- Read "[SAFETY PRECAUTIONS](#)" before reassembling the removed parts.
- If wire bundles are removed or moved during adjustment or part replacement, reshape the wires after completing the work. Failure to shape the wires correctly may cause problems such as noise.
- See [EXPLODED VIEW](#)

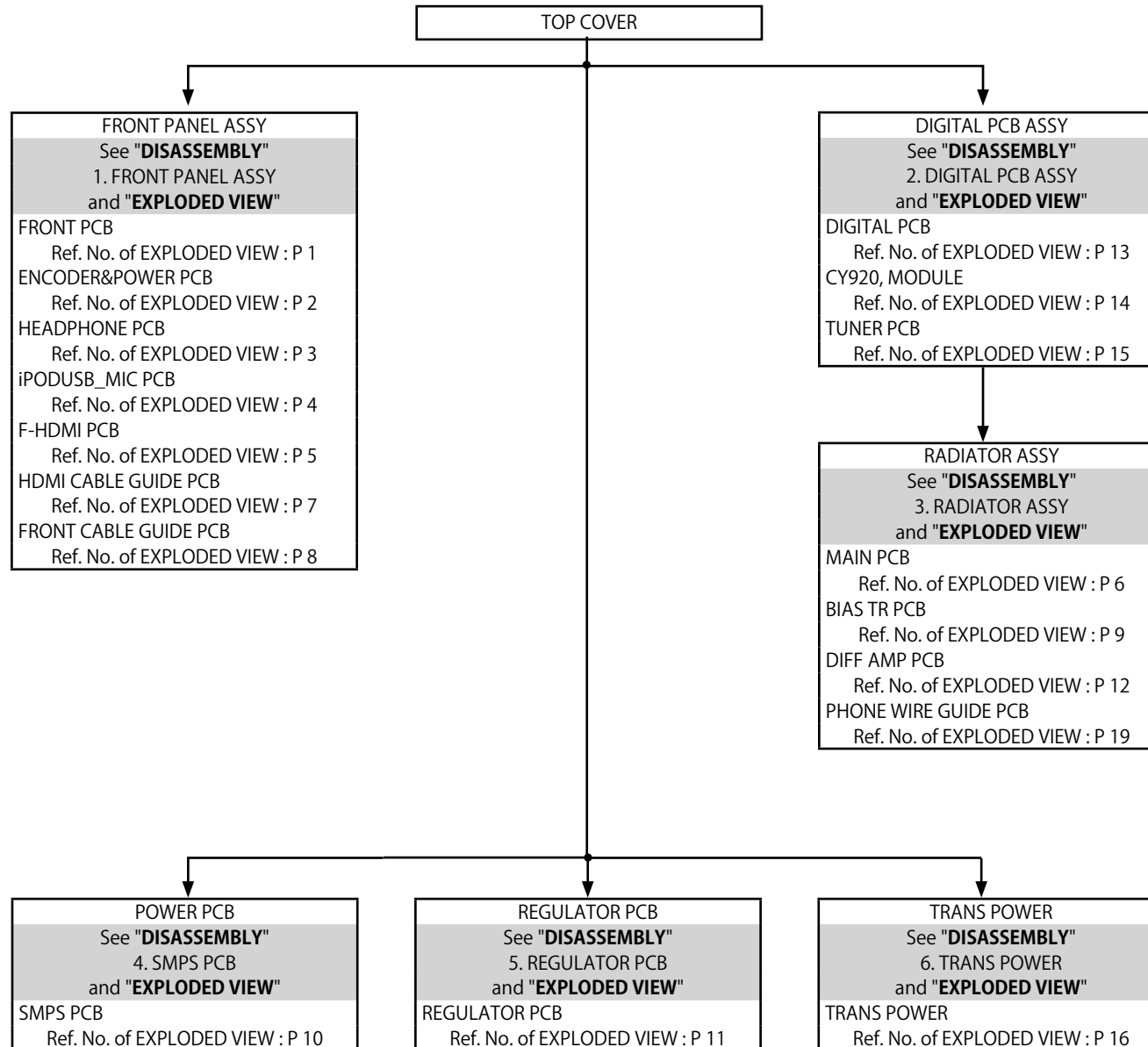

Explanatory Photos for DISASSEMBLY

- For the shooting direction of each photos used in this manual, see the photo below.
- **A, B, C and D** in the photo below indicate the shooting directions of photos.
- The photographs with no shooting direction indicated were taken from the top of the unit.
- Photos of AVR-S720W E3 are used in this manual.

The viewpoint of each photograph

(Shooting direction : X) [View from the top]

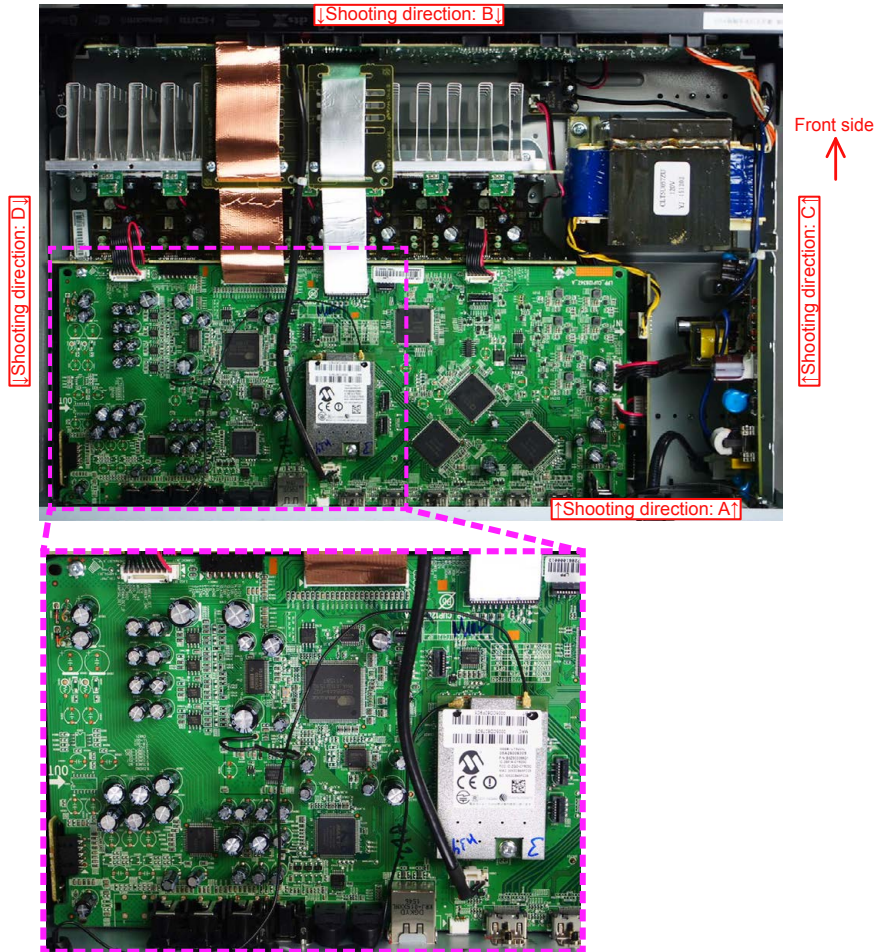

1. FRONT PANEL ASSY

Proceeding : **TOP COVER** → **FRONT PANEL ASSY**

- (1) Remove the screws.

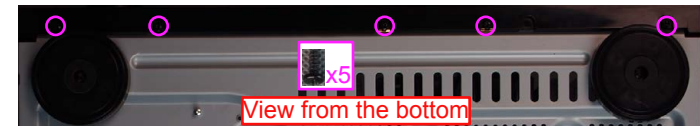

- (2) Remove the screws. Remove the CORD HOLDER and connectors. Remove the FFC.

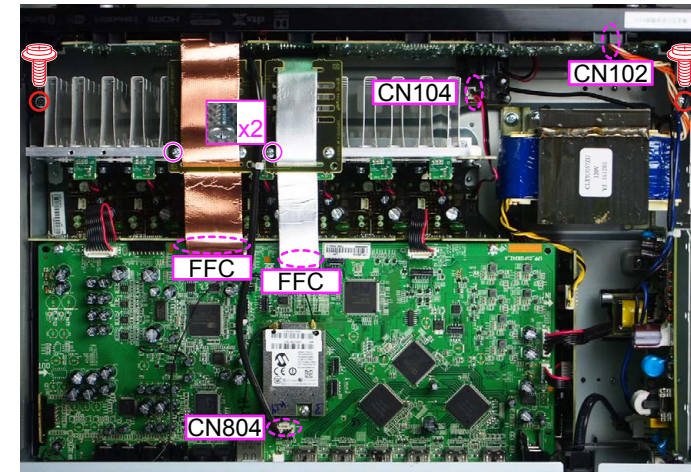

2. DIGITAL PCB

Proceeding : **TOP COVER** → **DIGITAL PCB**

(1) Remove the screws.



(2) Remove the CORD HOLDER and connectors. Remove the FFC. Remove the screws.

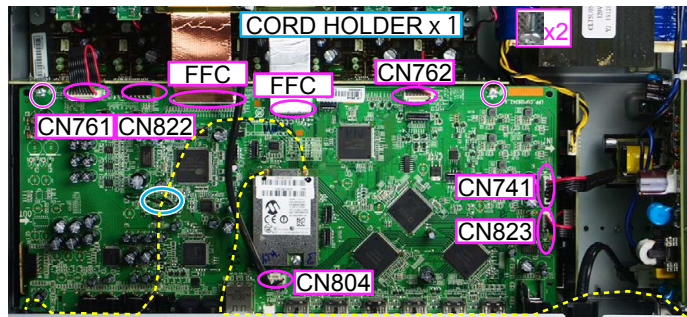

3. RADIATOR ASSY

Proceeding : **TOP COVER** → **DIGITAL PCB** → **RADIATOR ASSY**

(1) Remove the screws.



(2) Remove the screws. Remove the connector.

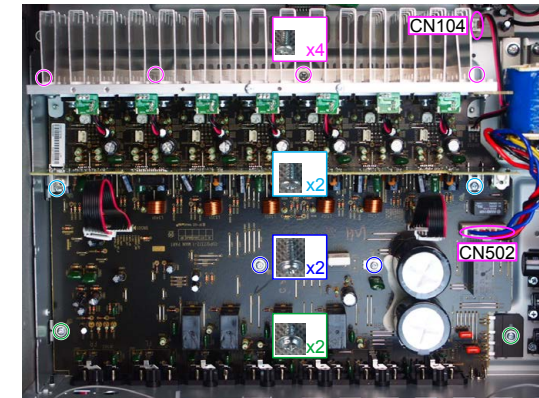

4. SMPS PCB

Proceeding : **TOP COVER** → **SMPS PCB**

See "EXPLODED VIEW" for instructions on removing the SMPS PCB.

5. REGULATOR PCB

Proceeding : **TOP COVER** → **REGULATOR PCB**

See "EXPLODED VIEW" for instructions on removing the REGULATOR PCB.

6. TRANS POWER

Proceeding : **TOP COVER** → **TRANS POWER**

See "EXPLODED VIEW" for instructions on removing the transformer (TRANS).

EXPLODED VIEW

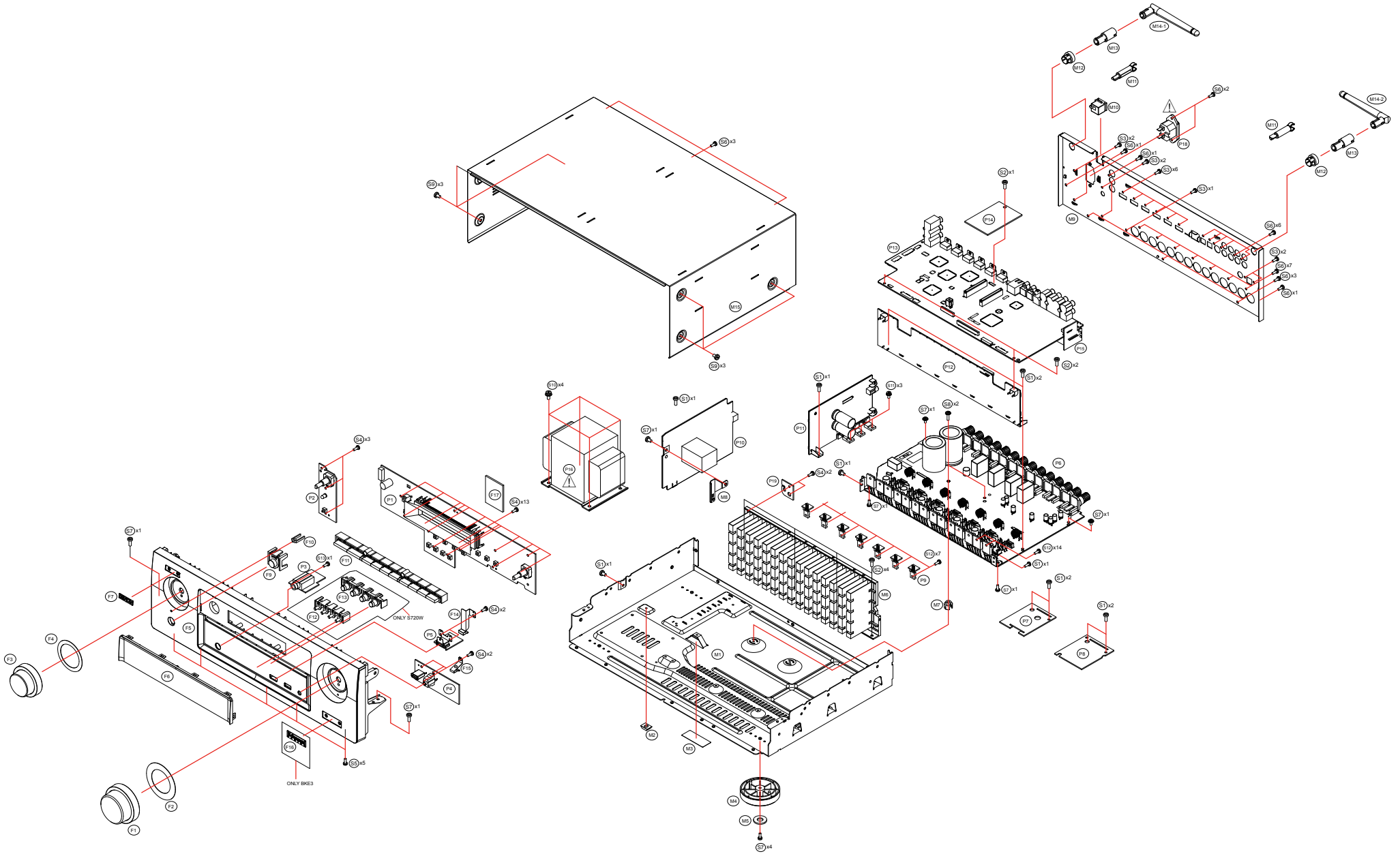

WARNING:
Parts marked with this symbol  have critical characteristics.
Use ONLY replacement parts recommended by the manufacturer.

Caution in servicing

Electrical

Mechanical

Repair Information

Updating

PACKING VIEW

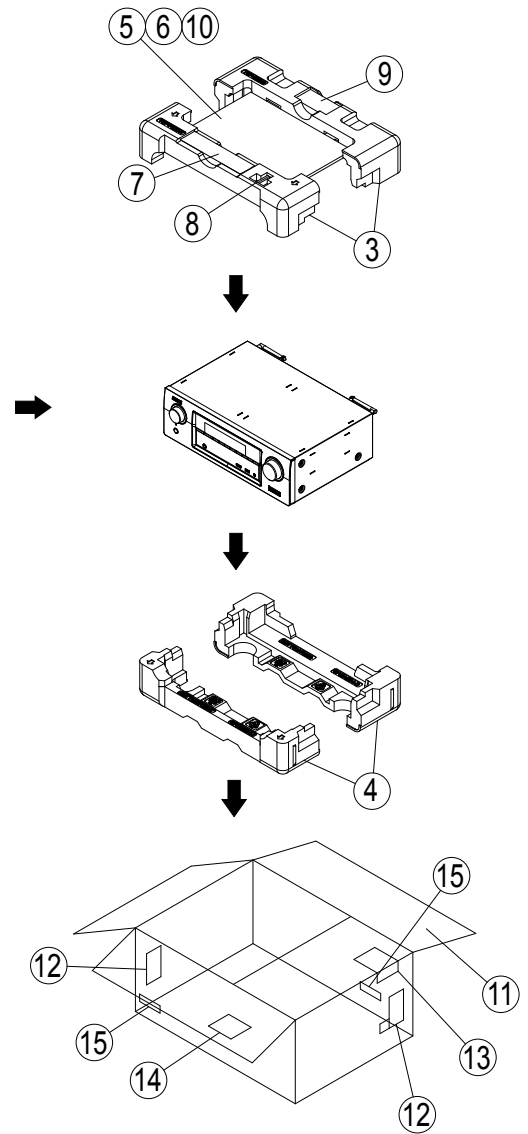
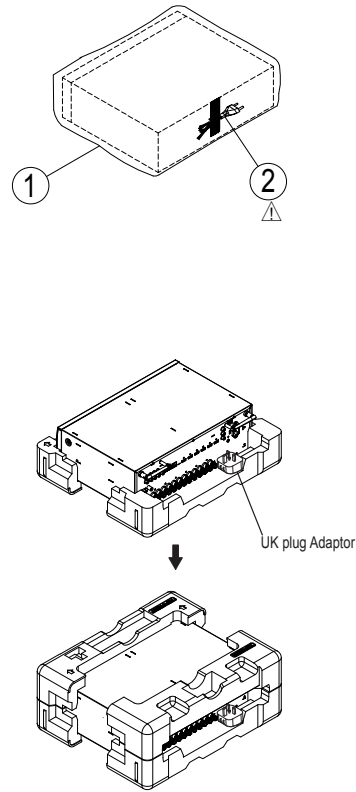
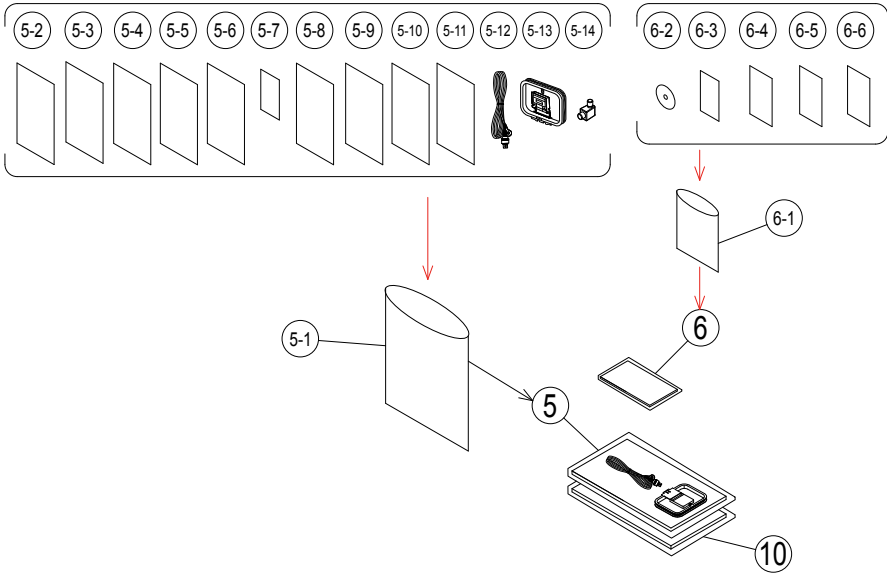

Caution in servicing

Electrical

Mechanical

Repair Information

Updating

REPAIR INFORMATION

TROUBLE SHOOTING

1. POWER
2. Analog video
3. HDMI/DVI
4. AUDIO
5. Network / Bluetooth / USB
6. SMPS

HDMI "Rx/Tx" Failure Detection

1. Prior checking
2. Preparations for checking HDMI Switcher reception/transmission register
3. Starting detecting the point of failure
4. Device implementation location

CLOCK FLOW & WAVE FORM IN DIGITAL BLOCK

SPECIAL MODE

Special mode setting button **AVR-X1300W**

Special mode setting button **AVR-S720W**

1. Version Display Mode
2. PANEL / REMOTE LOCK Selection Mode
- 3-1. Selecting the Mode for Service-related
- 3-2. Protection History Display Mode
- 3-3. Operation Info Mode
- 3-4. TUNER STEP mode (E2 / E3 only)
- 3-5. Remote ID Setup Mode
4. Protection Pass Mode
5. CY920 Reboot Mode
6. CY920 Initialization Mode
7. Clearing the Operation Info

DIAGNOSTIC MODE

Service Path Check Mode

DIAGNOSTIC PATH DIAGRAM

JIG FOR SERVICING

ADJUSTMENT

TROUBLE SHOOTING

1. POWER

1.1. The unit does not power on

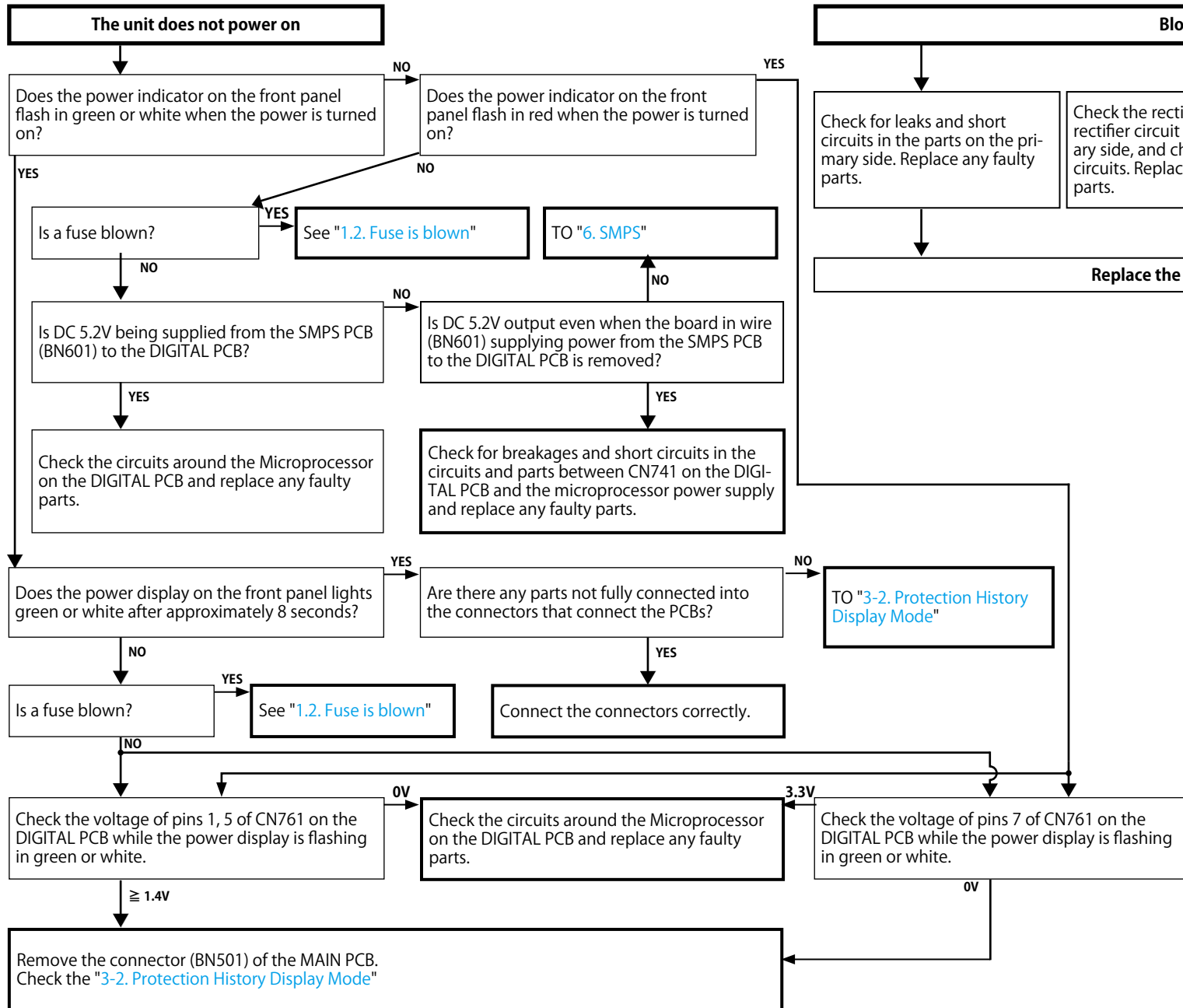

1.2. Fuse is blown

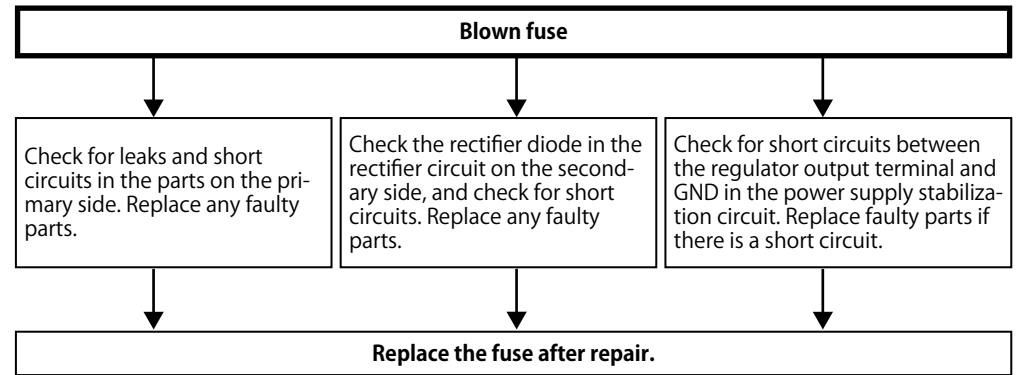

Caution in servicing

Electrical

Mechanical

Repair Information

Updating

2. Analog video

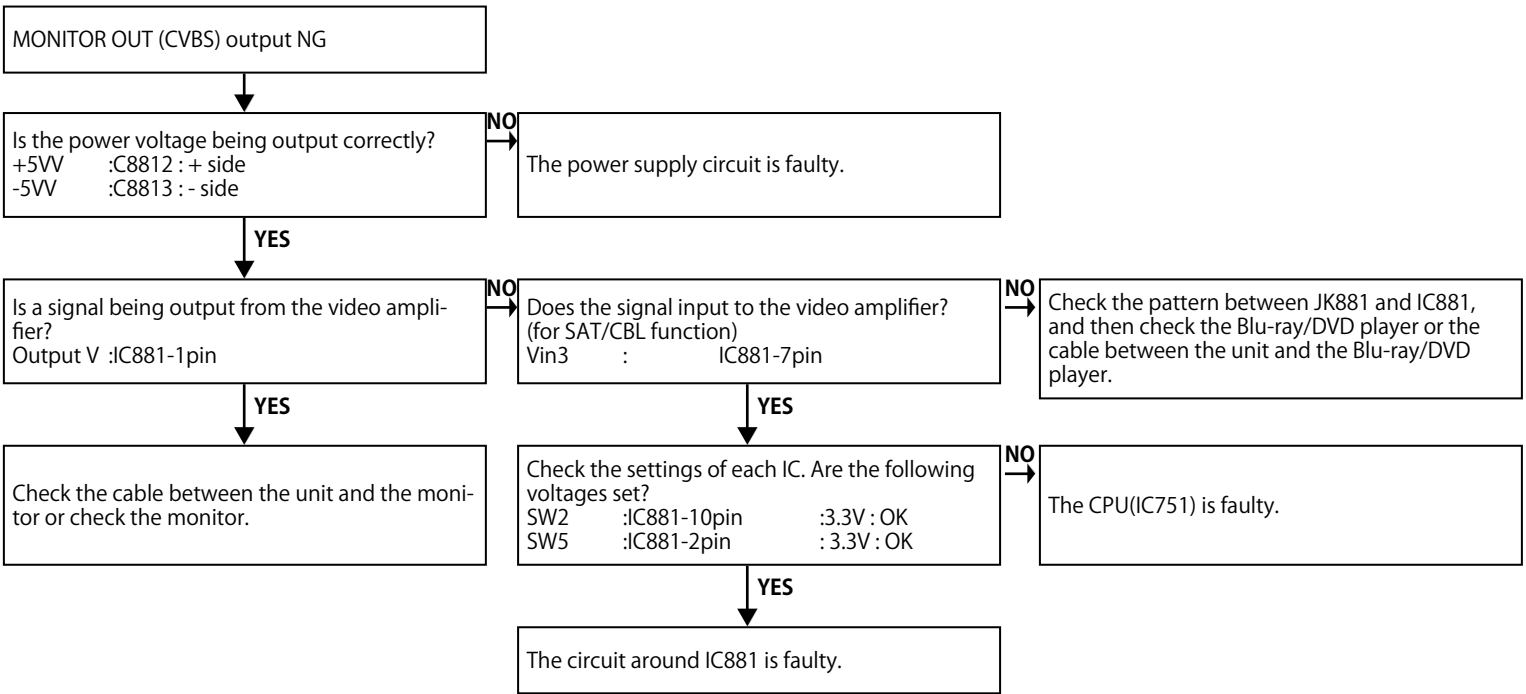

VIDEO test point

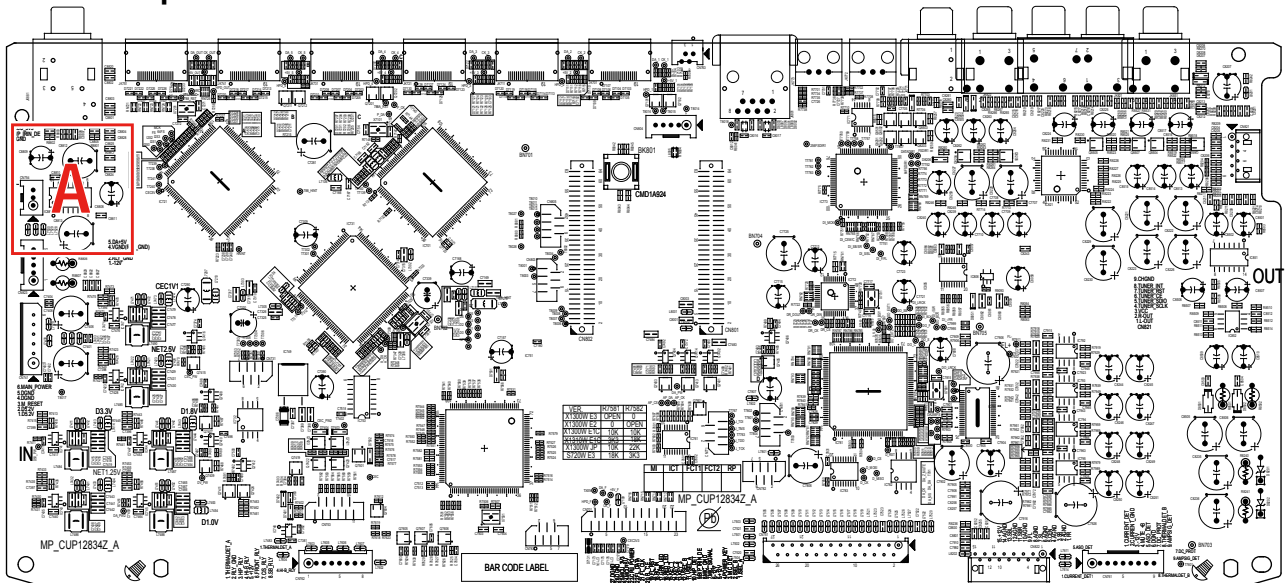

DIGITAL (COMPONENT SIDE)

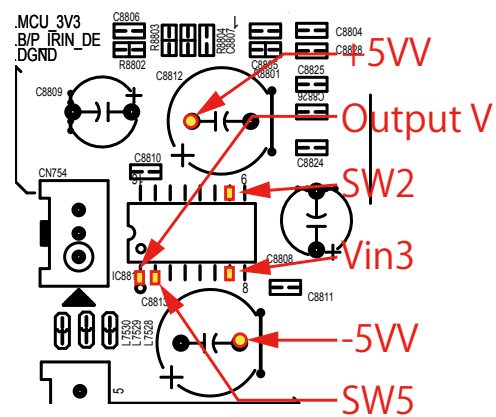

3. HDMI/DVI

3.1. No picture or sound is output (HDMI to HDMI)

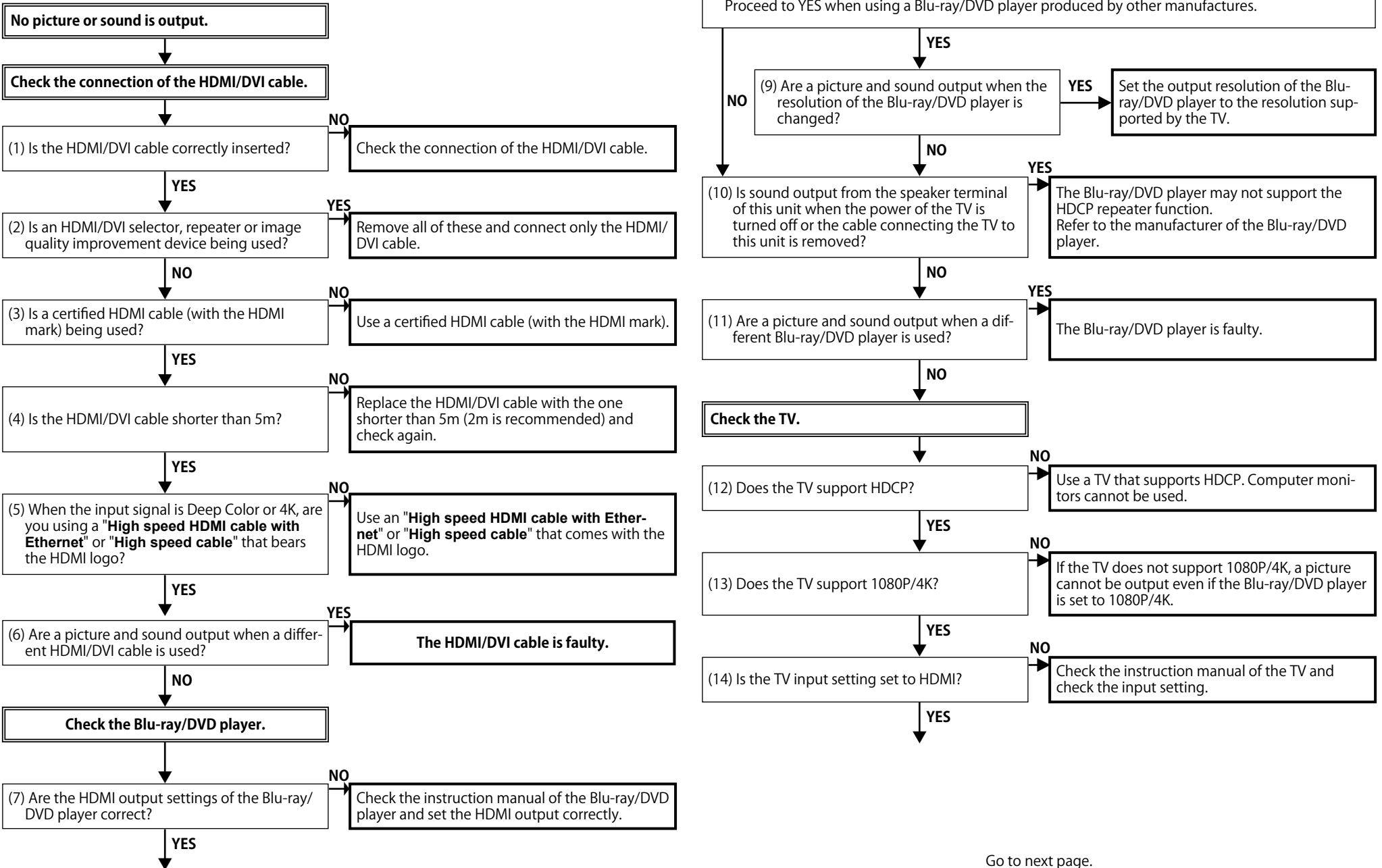

Caution in servicing

Electrical

Mechanical

Repair Information

Updating

Go to next page.

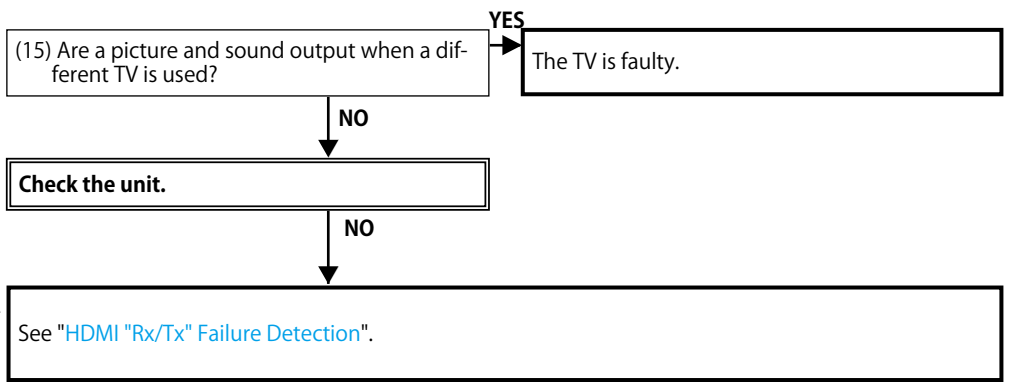

4. AUDIO

4.1. AUDIO CHECK

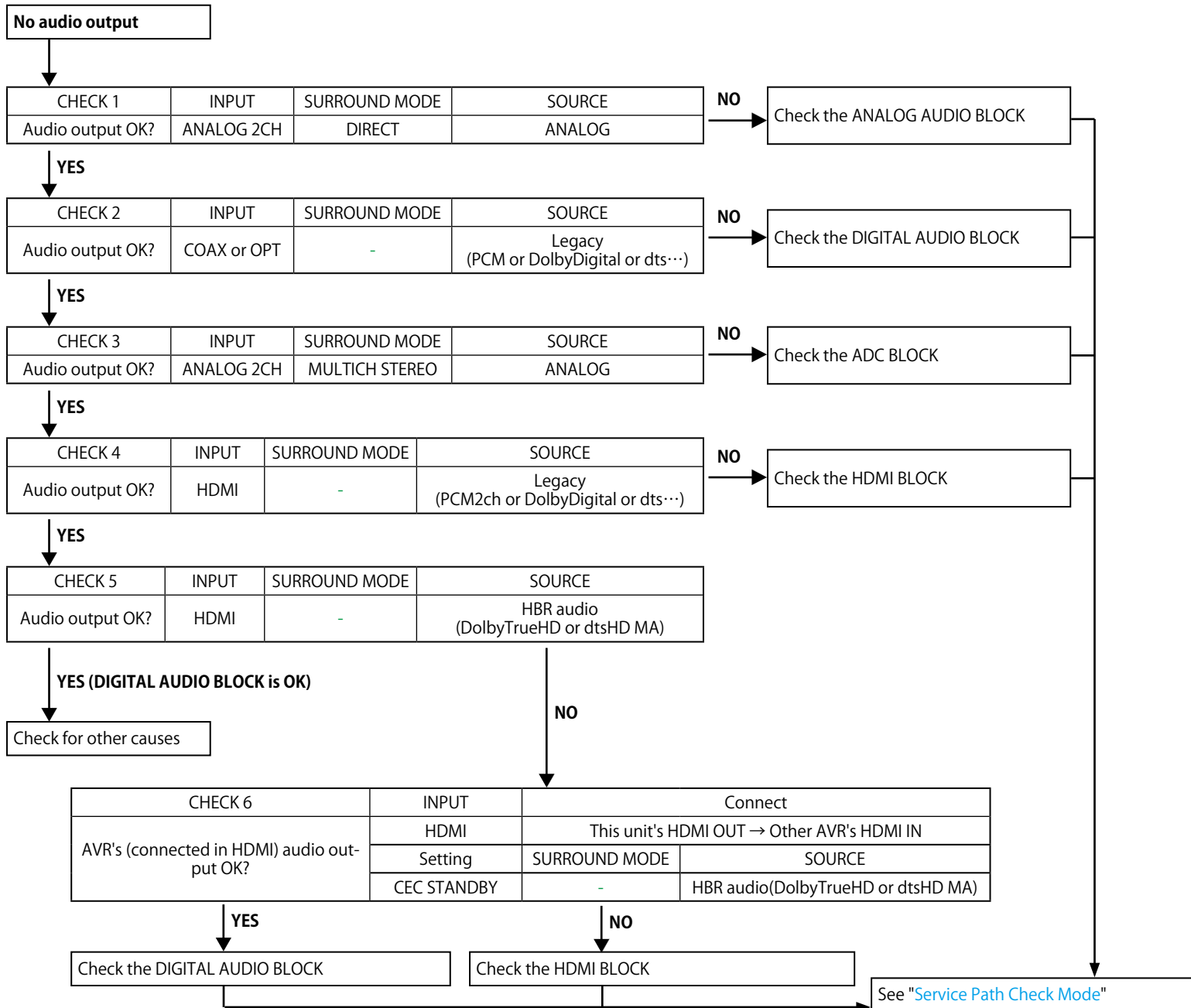

4.2. Power AMP (AMP PCB)

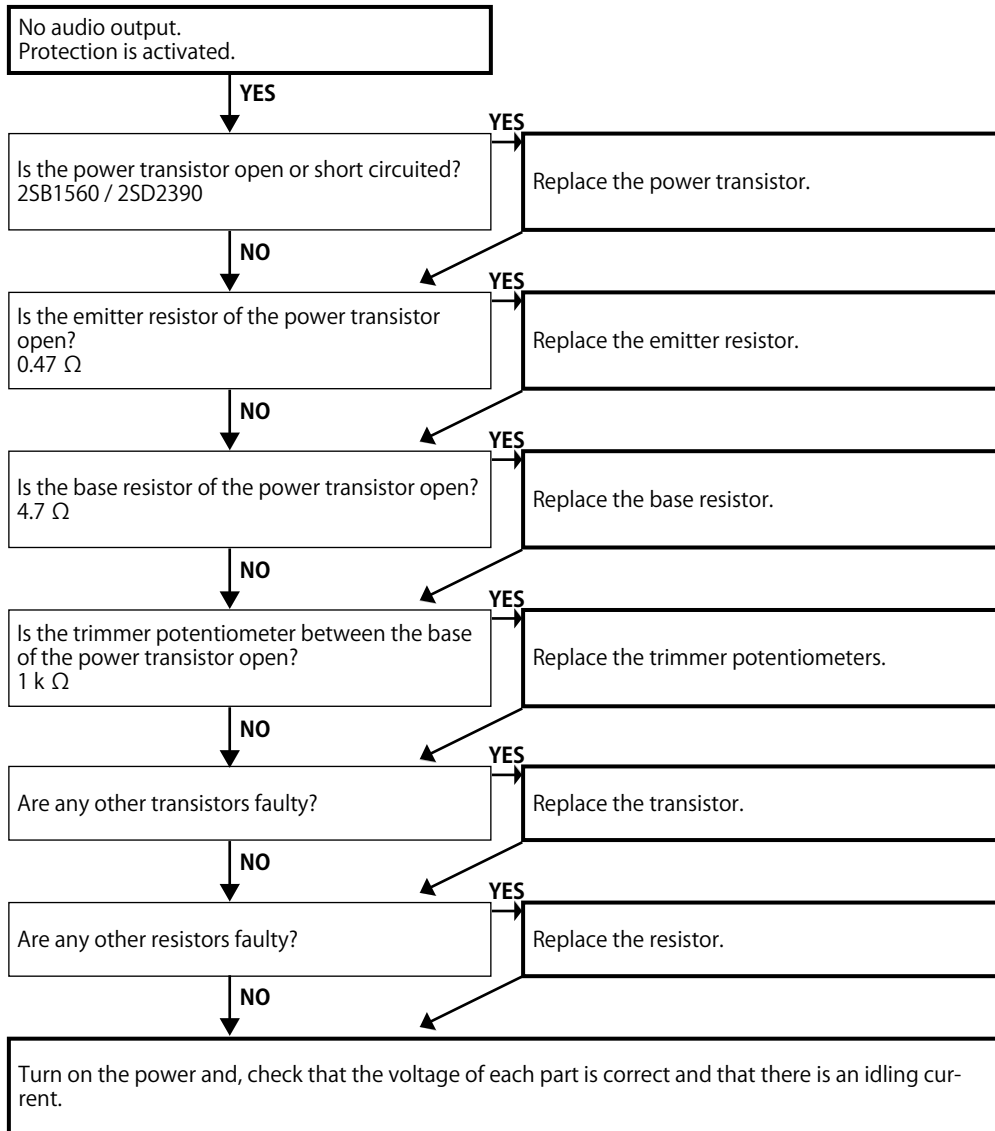

4.3. Analog audio

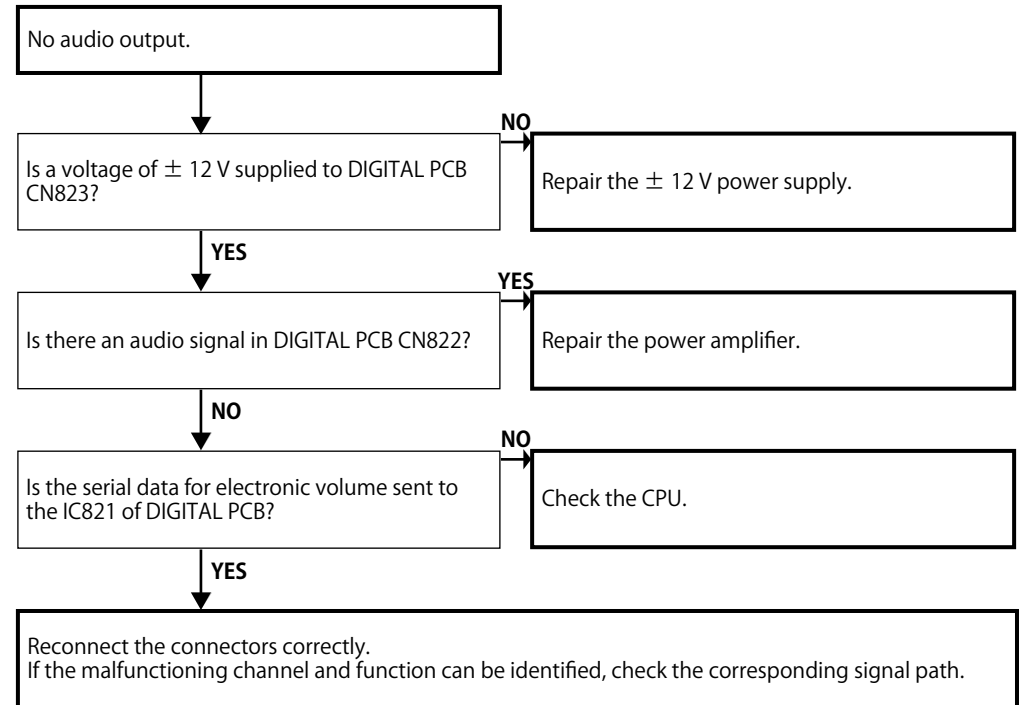

5. Network / Bluetooth / USB

5.1. Cannot connect to the network

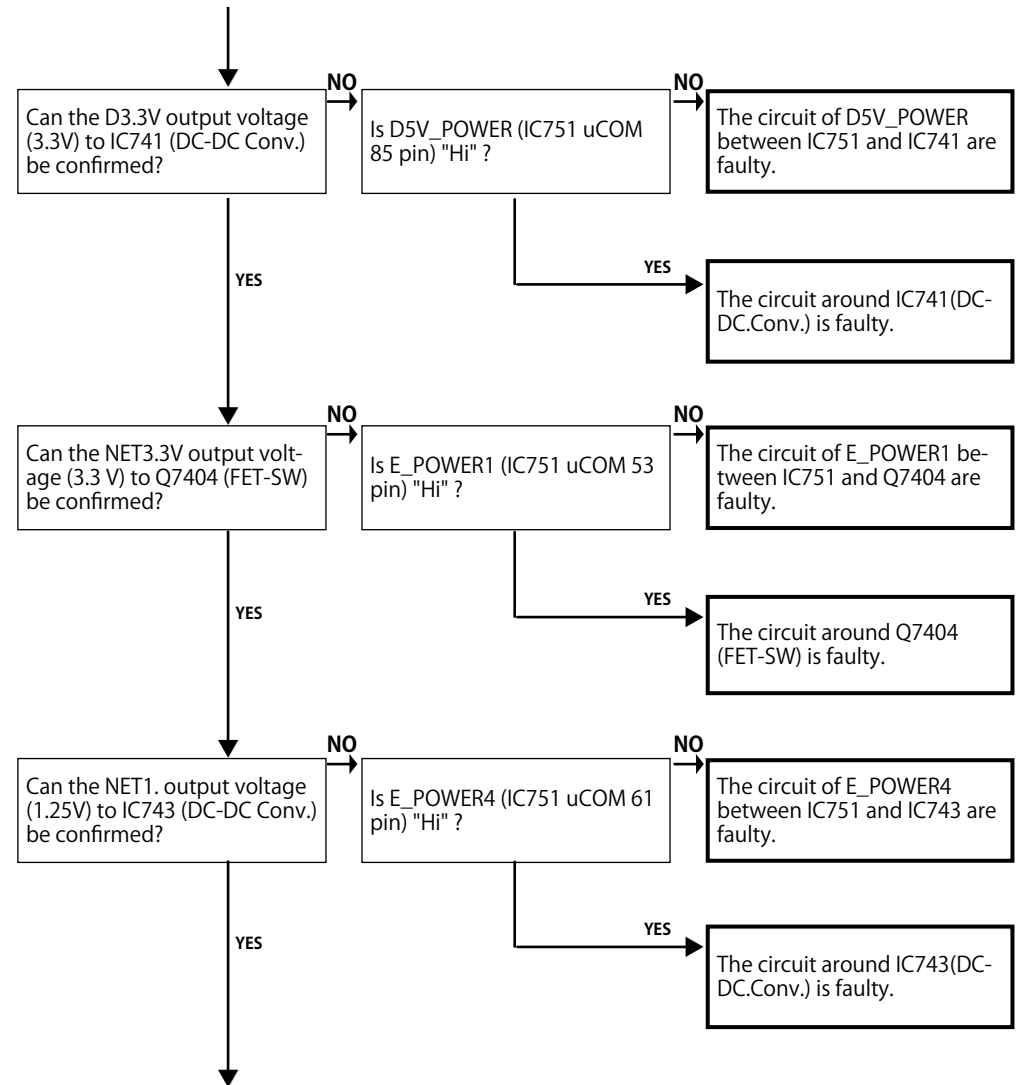
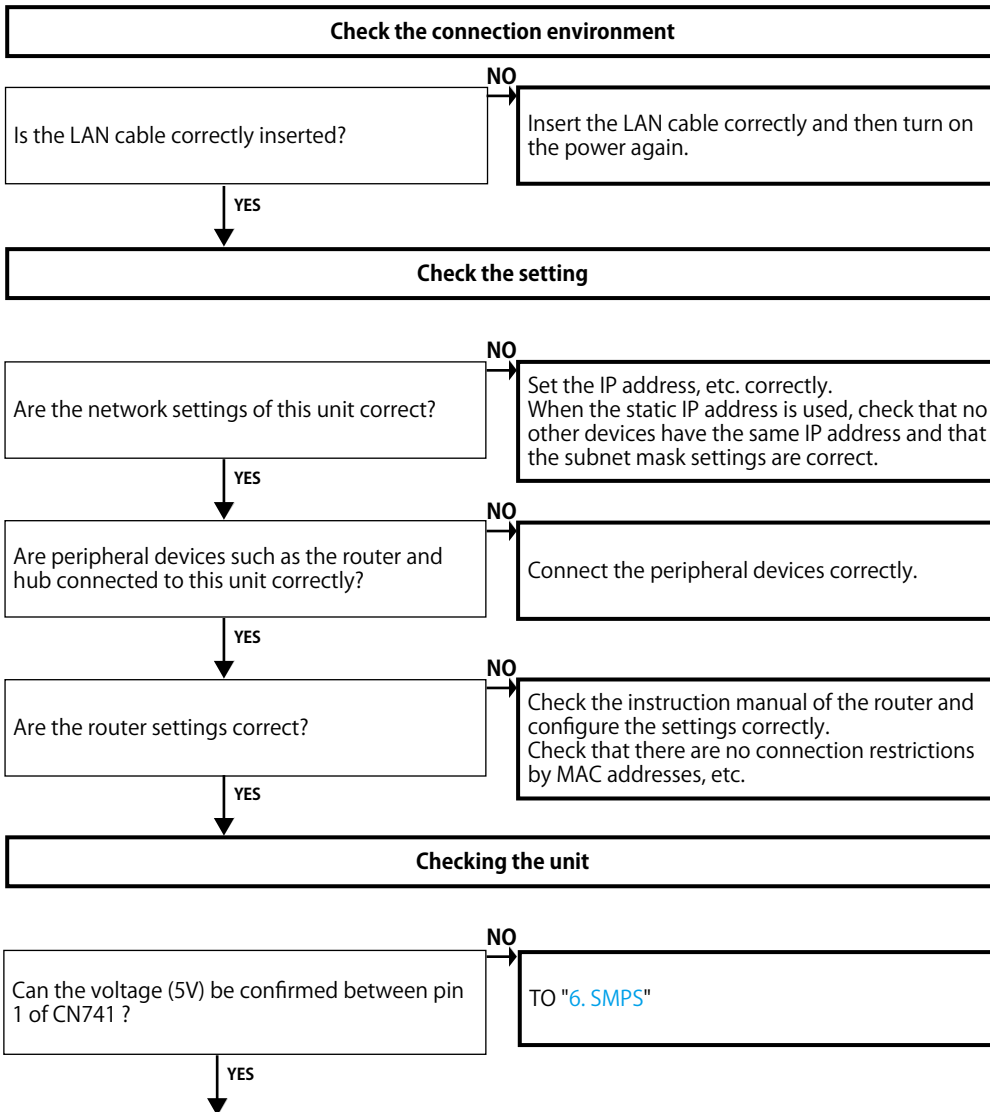

Go to next page.

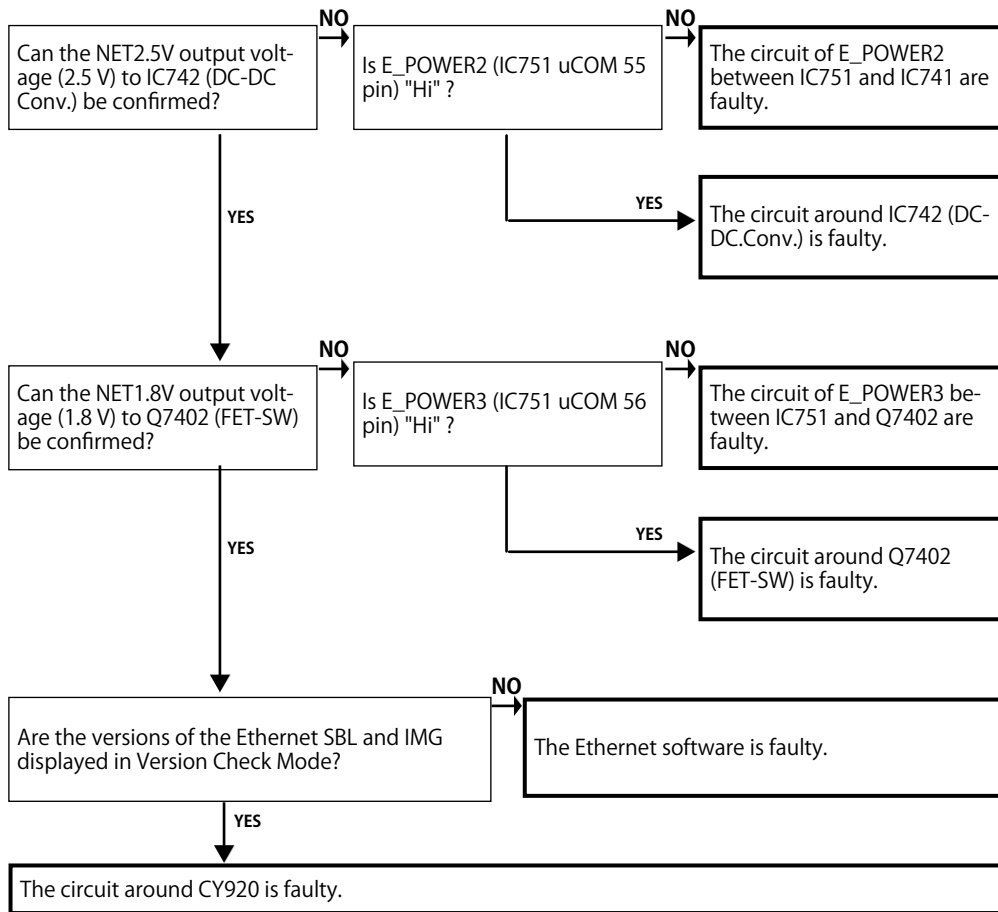

5.2. Cannot establish a Bluetooth connection

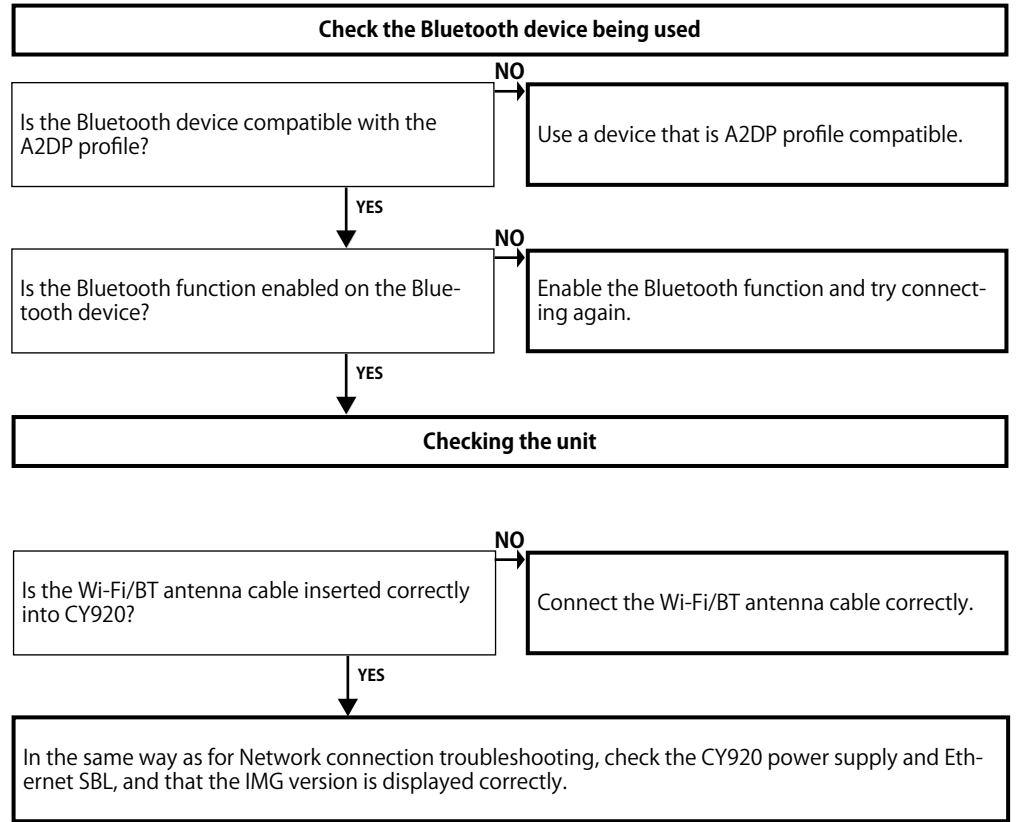

5.3. Cannot recognize the connected USB device

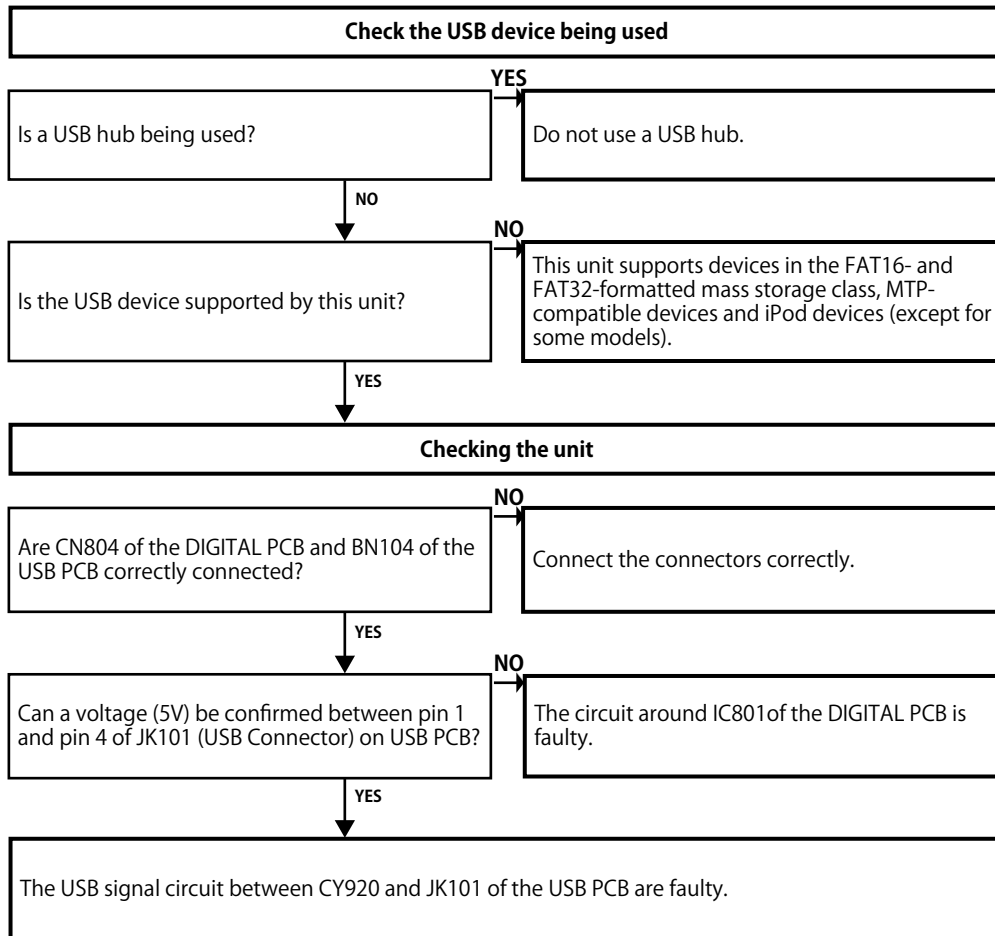

DIGITAL test point

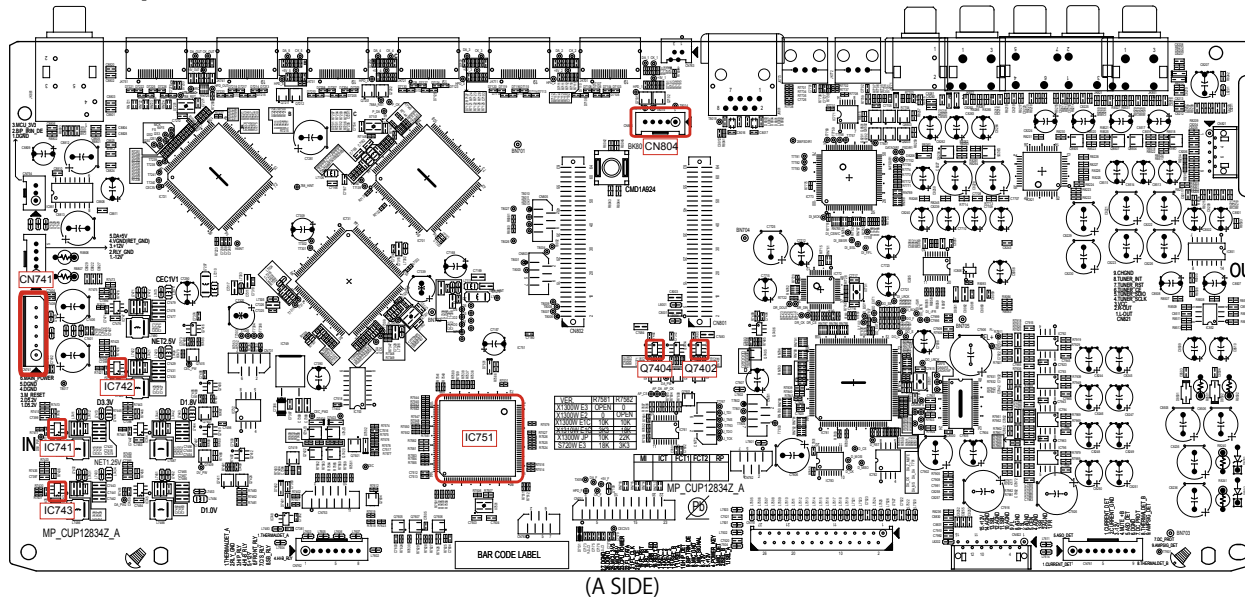

USB test point

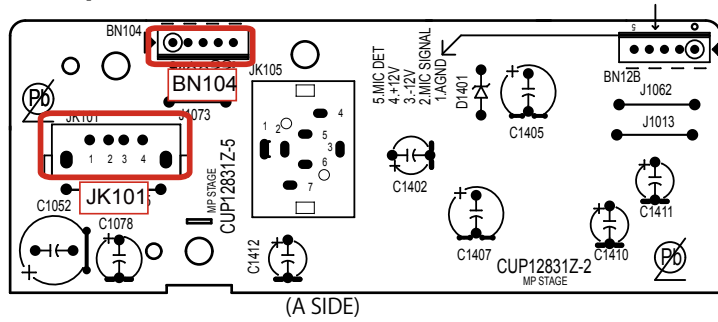

6. SMPS

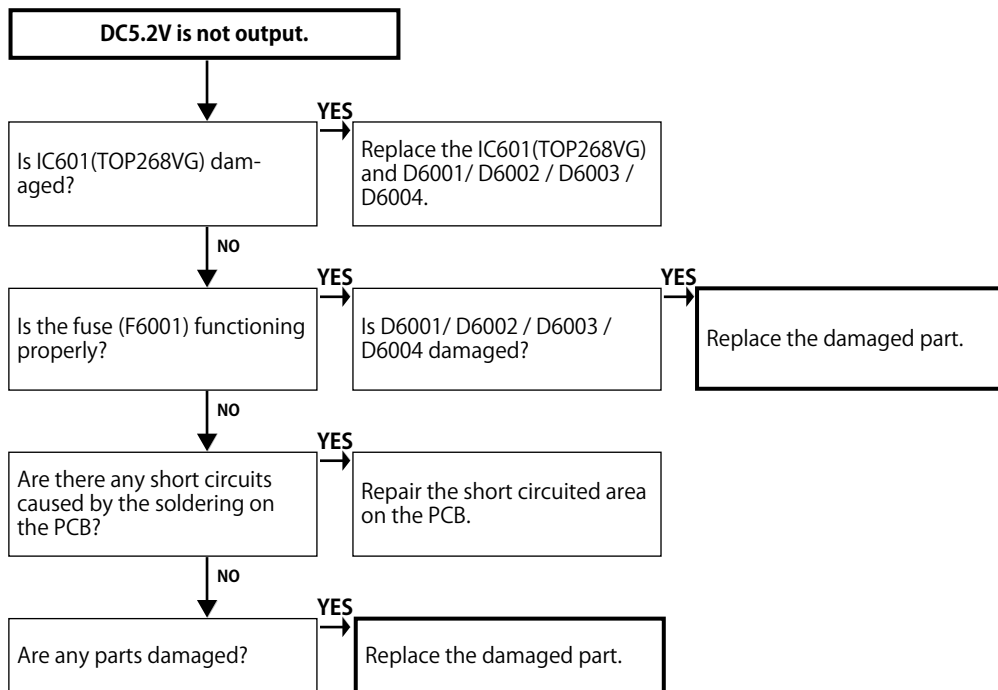

Operation waveform for each part

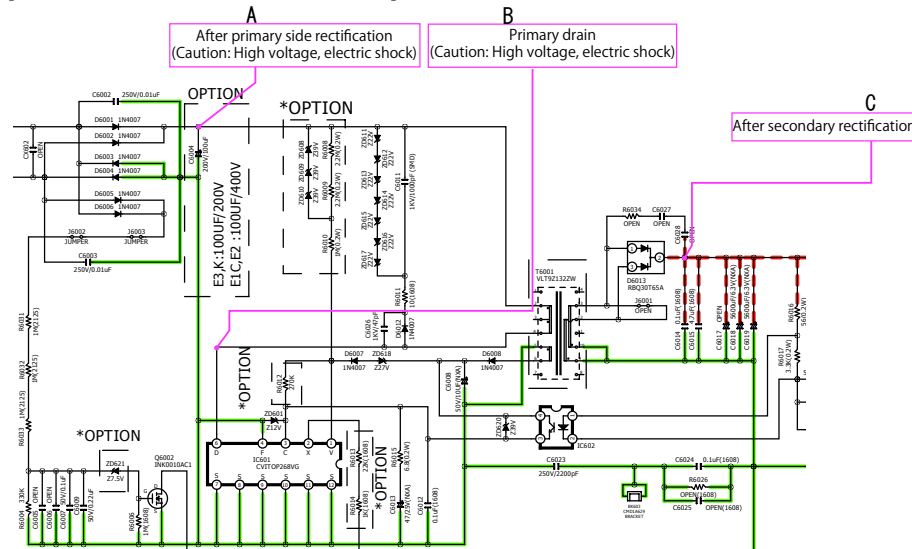

SMPS unit (Unloaded)

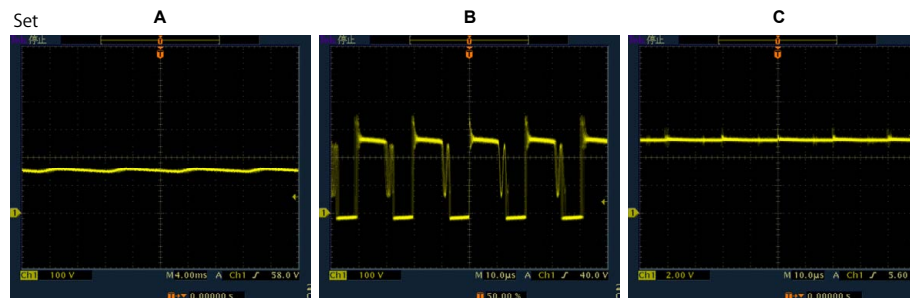
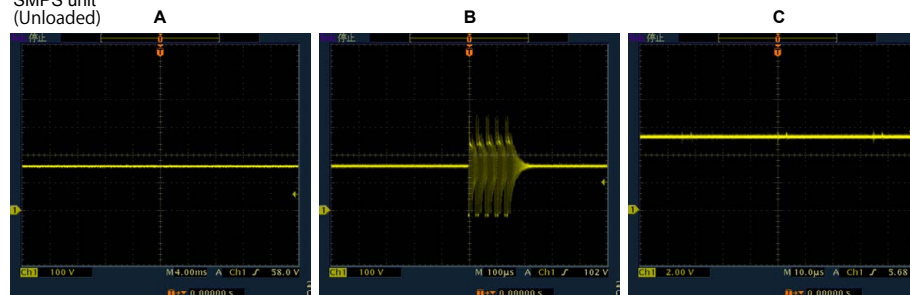

Caution in servicing

Electrical

Mechanical

Repair Information

Updating

1. Prior checking

Check item (0) : Checking the HDMI connector
Checking the condition of the HDMI pin (rear/front).

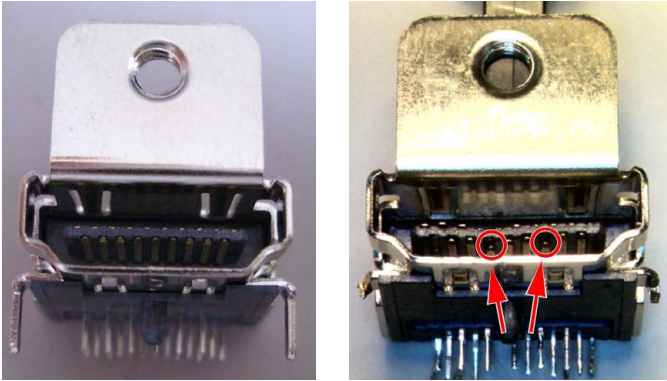

OK

NG

Check for deformed pins.

None of the pins are deformed.

There are deformed pins.

Replace the HDMI connector.

3. Check by following the flow chart for starting detection of the points of failure.

2. Preparations for checking HDMI Switcher reception/transmission register

2-1. Necessary devices

- 1) Check the product settings.
- 2-a) Player with an HDMI terminal
- 2-b) TV with an HDMI terminal (* NOTE : Do not use a computer monitor.)
- 3) Windows PC
- 4) Serial communication software "termite.exe"
(Download the software from http://www.compuphase.com/software_termite.htm and install it.)
- 5) HDMI cable
- 6) RS-232C Straight cable
- 7) 8U-2120100S WRITING KIT
- 8) oscilloscope

2-2. Device Connection Method

Connect the TV and the AVR to the player using an HDMI cable and connect the AVR to the PC through an RS-232C cable as shown in Figure 1.

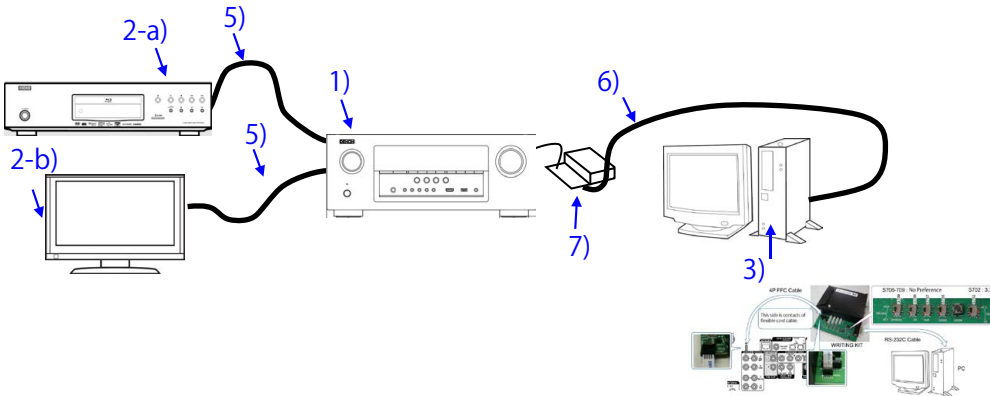

Figure 1-1 Device Connection Method (AVR-X1300W/S720W)

2-3. Device configuration method

PC settings : Execute the serial communication program, Termite.exe.

After executing Termite.exe, click [Settings].

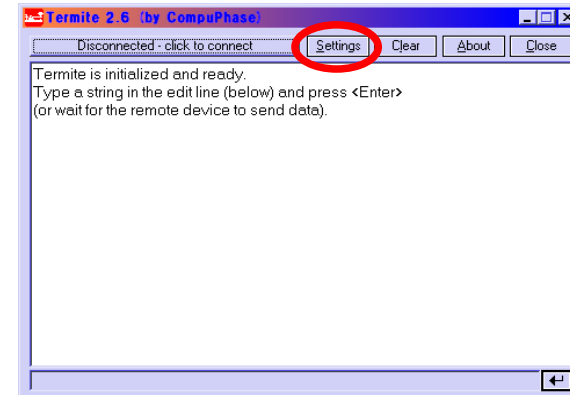

Figure 2 Screen After Executing Termite.exe

The serial port setup screen will be displayed. Configure the settings as shown in Figure 3 and click the [OK] button.

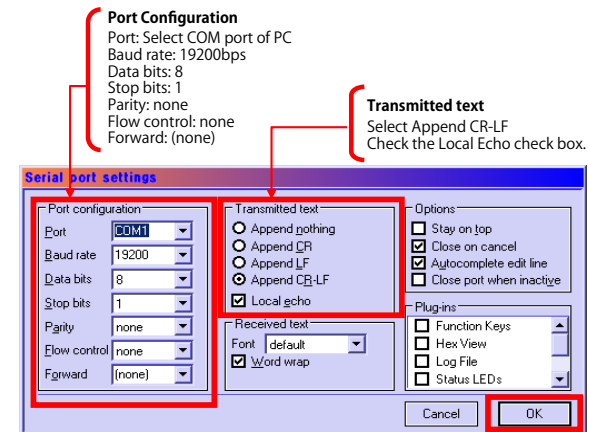

Figure 3 Serial Port Setup Screen

Click the [click to connect] button to start communication.
 After a connection is established successfully, the display of the button name will change as shown in Figure 4.

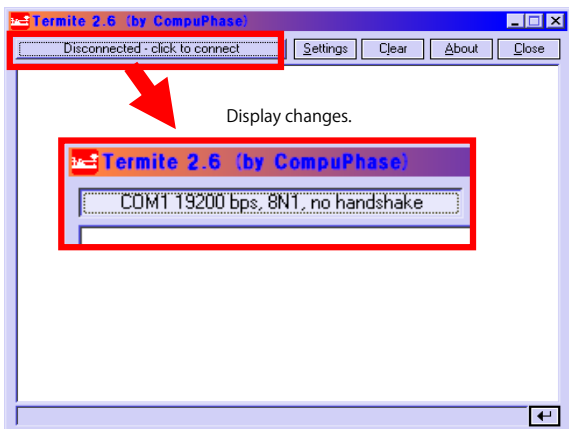

Figure 4 Change of the Display of the Communication Start Button Name

TV settings : Switch to the HDMI input in the AVR connection.
 Player settings : Turn the unit power on and configure it to play disks.
 ⚠ AVR settings : While the power is on, hold down buttons "PRESET UP" and "ZONE2 SOURCE" for at least 3 seconds.
 (Continue to press and hold the buttons until all segments of the FLD volume illuminate.)
 ※ When the power is turned on after initialization, "Setup Assistant" will be displayed.
 After exiting "Setup Assistant," execute the above.

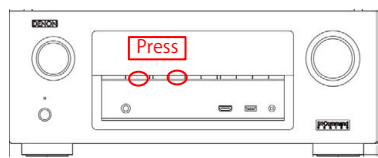

Figure 6-1. AVR settings (AVR-X1300W)

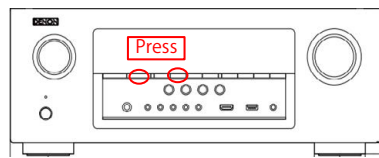

Figure 6-2. AVR settings (AVR-S720W)

for Volume 7 segment
 All the indicator Lights



Figure 6 FLD Display When Set

When the settings are correct, the following message will be displayed in the window of Termite.
 [00]Start Sub CPU Log Mode

 (**** is a version of Sub CPU.)

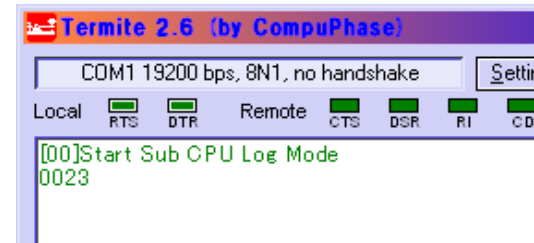

Figure 7 Display of Termite When AVR is Set

The setup is now complete.

Method for sending commands

Enter the command in the transmission command entry section, click the [Send] button and send the command.

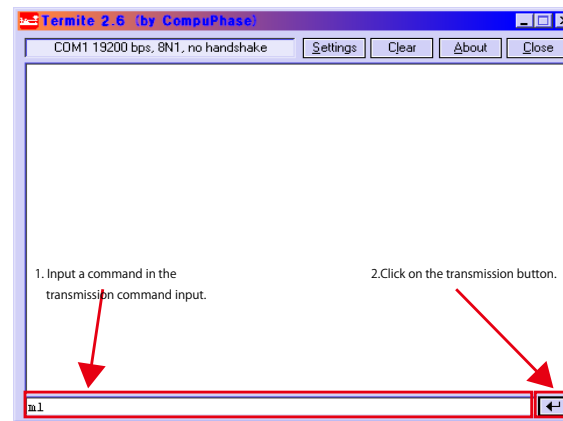

Figure 8 Method for Sending Termite Commands

3. Starting detecting the point of failure

3-1 Check the "HDMI/DVI" item in troubleshooting.



Check item(1).
Check that the version of the AVR can be read correctly.
Is the GUI version readable correctly?

YES

NO
After rewriting the GUI ROM, check the GUI version.
If it does not work, replace the GUI Rom(IC732) and recheck the GUI Ver.
If it does not work, replace the PCB.

Check item(2). : Check operation of the HDMI input terminal.



When the HDMI input terminal of this device is connected to the player correctly, is sound heard from the speaker?
※ When checking, turn the AV amplifier on and off after checking the connection terminal with the player. (To set the same conditions during verification of operation)

Check that sound is heard from the input terminal of the HDMI 4 / 5.
Use any of Dolby TrueHD/DTSHD MA/PCM 8ch for the playback audio format.

NO
Is the "DIG" indicator illuminated on the FLD?
When the "DIG" indicator is illuminated, the digital audio block is faulty.
If the "DIG" indicator is not illuminated, go to [check item \(5\)](#).
(HDMI Rx/Tx IC(MN864788)failure detection procedure)

YES

Check that sound is heard from the input terminal of the HDMI 1 - 3.

NO
Go to [check item \(18\)](#)
HDMI SW (MN864788A) failure detection procedure

YES

Check that sound is heard from the input terminal of the HDMI 6.

NO
Go to [check item \(29\)](#)
(Front HDMI Buffer IC(AD8195)failure detection procedure)

YES

Check item(3). : Check operation of the HDMI output terminal.



When the "SETUP" button on a remote control is pressed, is "MENU" displayed on TV which is connected to the HDMI output terminal on the AVR?

YES

NO
Go to [check item \(37\)](#)
(OSD (ADV7623) failure detection procedure)

Check item(4). : Check operation of the HDMI output terminal.

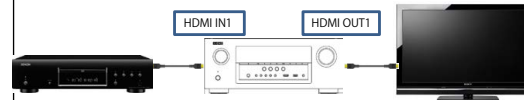

When the player is connected to the HDMI input terminals in order, are the images on the player displayed on the TV in both cases?

YES

NO
Go to [check item \(52\)](#)
(Between HDMI Tx(MN864788) & OSD(ADV7623) failure detection procedure)

There is no problem with Rx, Tx, and GUI of HDMI as well as IC of SW.

3-2 HDMI Rx/Tx MN864788)failure detection procedure

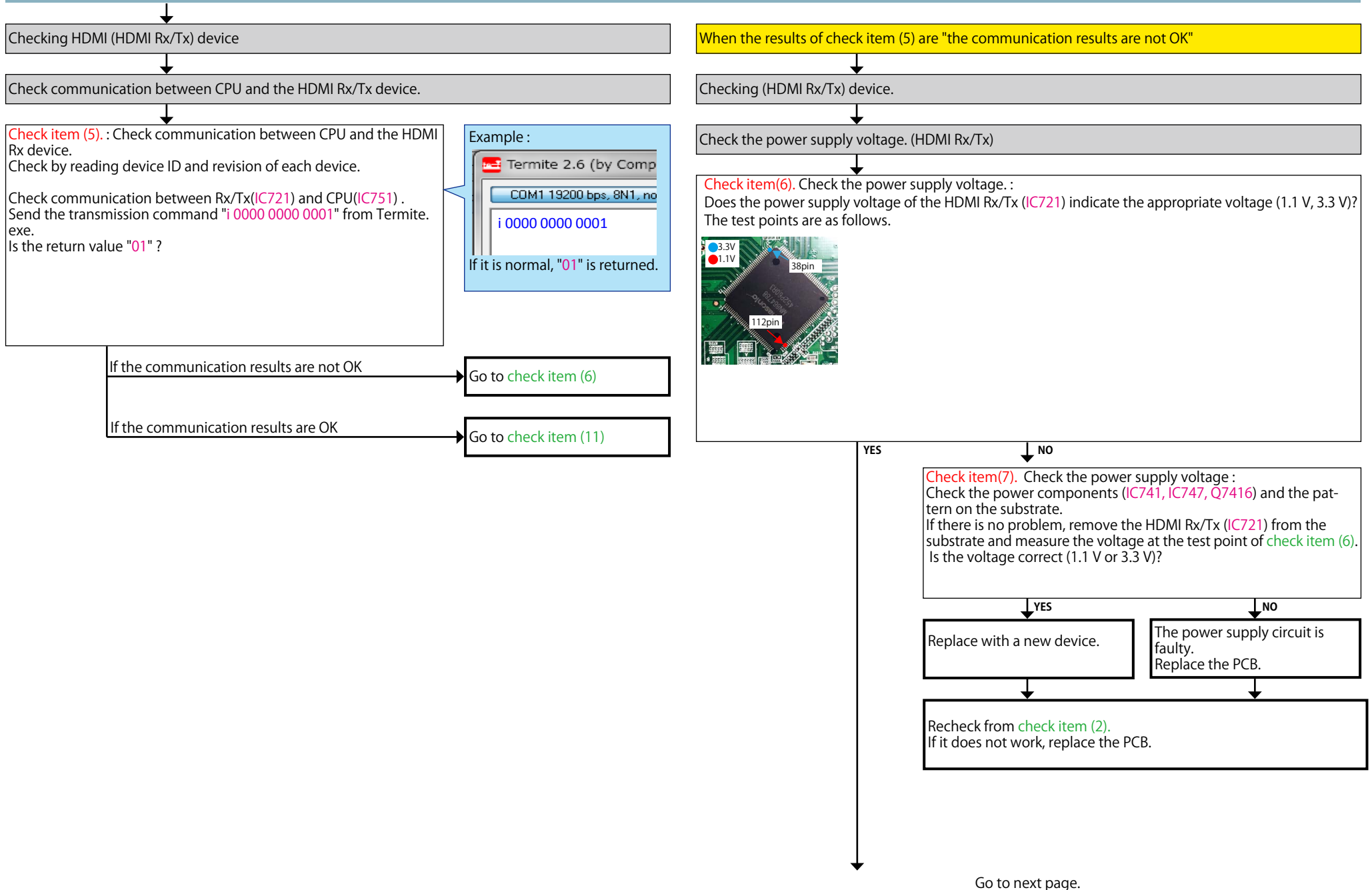

Caution in servicing
Electrical
Mechanical
Repair Information
Updating

Checking the reset waveform (HDMI Rx/Tx)

Check item(8). Checking the reset waveform :
Check the waveform.
Is the "I2C" waveform of the TP near the HDMI Rx (**IC721 115pin**) correct (like the one shown in the diagram) when the power is turned on?

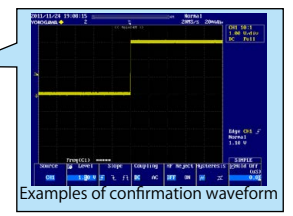

NO
Check the reset circuit between CPU (**IC751**) and HDMI Rx/Tx (**IC721**).
If there is no problem, the HDMI Rx (**IC721**) is faulty.
Replace with a new device.
Recheck from **check item (2)**.
If it does not work, replace the PCB.

Check the I2C communication line. (HDMI Rx/TX)

Check item(9). Check the I2C communication line :
Check the CPU.
Is the "I2C" waveform of the TP near the HDMI Rx (**U1000**) correct (like the one shown in the diagram) when the power is turned on?

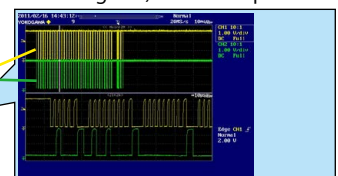

Points for checking waveforms
- Crest value (3.3 V normally)
- Signal change
- SCL frequency (400 kHz normally)

NO
Check item(10). Check the I2C communication line :
Check HDMI Rx/Tx (**IC721**), and CPU(**IC751**) patterns as well as soldering.
If there is no problem, go to the next step.

The HDMI Rx/Tx (**IC721**) is faulty.
Replace with a new IC.

Recheck from **check item (2)**.
If it does not work, replace the PCB.

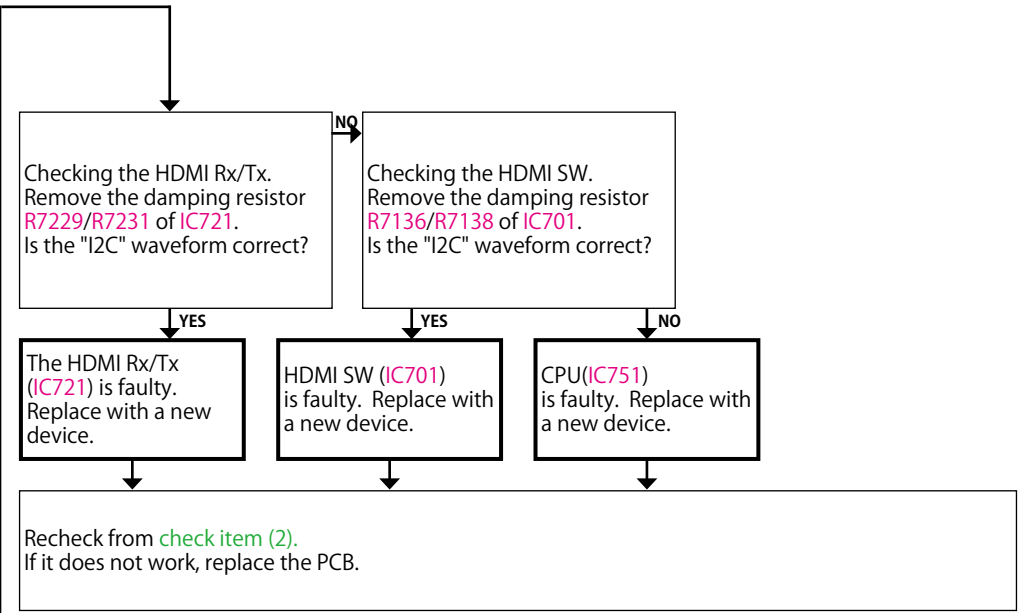

When the results of check item (5) are "the communication results are OK"

Checking operation between the HDMI (Rx/Tx) device and the player



※ In order to check, connect the player to the HDMI terminal and configure the player as AVR source. Check the sound output while turning on the player.

Checking the +5V/DDC status register (HDMI Rx/Tx)

Check item(11). Checking the +5V status register :
Send the following command from Termite.exe.
Send the transmission command "i 0006 00FF 0001" from Termite.exe.
Move to the branch destination according to the value returned.

Example

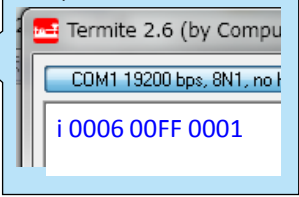

HDMI in 4/5 "00"
(Detection of 5V is not OK.)

Go to **check item (13)**

HDMI In4 "22 or 20" HDMI In5 "11 or 10"
(Detection of 5V is OK)

Check item(12). Checking the +5V/DDC status register :
Send the following command from Termite.exe.
When the HDMI IN4, Send the transmission command "i 0003 0054 0001" from Termite.exe.
When the HDMI IN5, Send the transmission command "i 0003 0024 0001" from Termite.exe.
Move to the branch destination according to the value returned.

Example

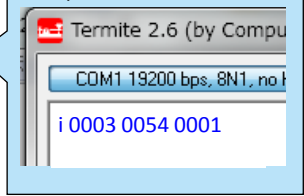

"00 or 04"
(Detection of DDC is not OK.)

Go to **check item (14)**

"22"
(Detection of DDC is OK)

Go to **check item (15)**

Caution in servicing

Electrical

Mechanical

Repair Information

Updating

When the results of check item (11) are "00"
(Detection of 5V is not OK)

Checking +5 V voltage (HDMI Rx/Tx)

Check item(13). Check the +5V voltage :
Does "+5 V" at the following test point indicate 5 V? (JK731/JK741)

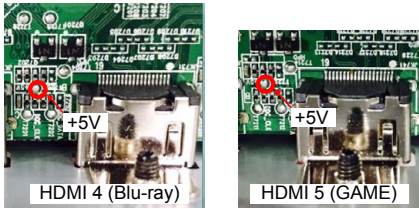

YES

The HDMI Rx/Tx (IC721) is faulty.
Replace with a new device.

NO

Check for a short circuit in the 5 V line and the 5 V Switch IC (IC733).
If there is no problem, the HDMI Rx/Tx (IC721) or the 5 V Switch IC (IC733) is faulty
Replace with a new device.

Recheck from check item (2).
If it does not work, replace the PCB.

When the results of check item (12) are "00 or 04"
(Detection of DDC is not OK.)

Check the DDC line (HDMI Rx/Tx)

Check item(14). Check the DDC line :
Are waveforms of "DDCSCK" and "DDCSDA" observed at the test point near the HDMI input terminal?

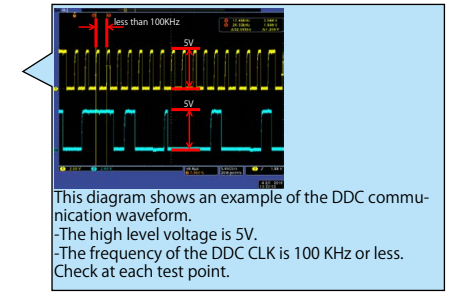
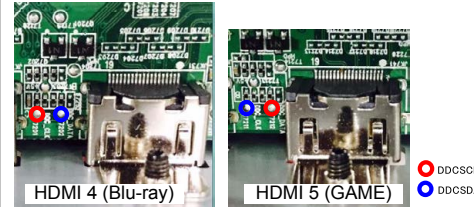

YES

The HDMI Rx/Tx (IC721) is faulty.
Replace with a new device.

NO

Check for a short circuit in the DDC line.
If there is no problem, the HDMI Rx/Tx(IC721) is faulty.
Replace with a new device.

Recheck from check item (2).
If it does not work, replace the PCB.

When the results of check item (12) are "22"
(Detection of DDC is OK.)

Checking the TMDS status register

Check item(15). Checking register of the TMDS CLK detection status register :
Send the following command from Termit.exe.
HDMI Rx/Tx
Send the transmission command "i 0006 00FF 0001" from Termit.exe.
When the following value is returned, go to Yes.
HDMI In4 "22" HDMI In5 "11"
When the following value is returned, go to No.
HDMI In4 "20" HDMI In5 "10"

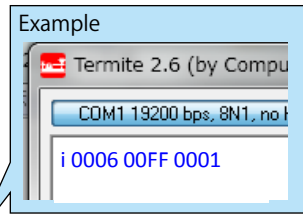

NO

Check item(17). Checking the audio signal output :
Check the audio signal waveform at the following test point.
Is the waveform like the sample?



129/131/132/133/134/135/136pin

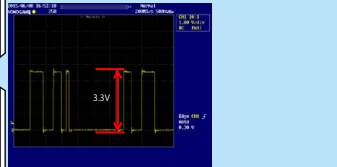

The diagram shows an example of the waveform of pin 129. (I2S0 Data)
Waveform check points
- Crest value (3.3 V normally)
- Signal change
Check the waveform of each pin.

YES
The digital audio block is faulty.
Check the digital audio device.
Check "AUD0" in troubleshooting.
If it does not work, replace the PCB.

NO
The HDMI Rx/Tx (IC721) is faulty.
Replace with a new device.

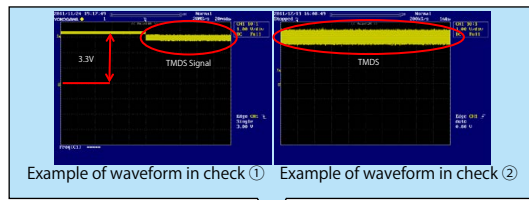

Example of waveform in check ① Example of waveform in check ②

Check item (16). Checking the TMDS input waveform. :
Check the TMDS waveform at the following test point.
Is the waveform like the sample?

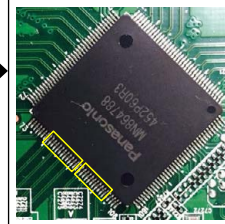

HDMI In4
80/81/83/84/86/87/89/90pin
HDMI In5
93/94/96/97/99/100/102/103pin

YES

The HDMI Rx/Tx (IC721) is faulty.
Replace with a new device.

NO

Check for a short circuit in the pattern of the TMDS line of the HDMI Rx/Tx (IC721) from the HDMI input terminal.
If there is no problem, the HDMI Rx/Tx(IC721) is faulty. Replace with a new device.

Recheck from **check item (2)**.
If it does not work, replace the PCB.

3-3 HDMI SW(MN864788A) failure detection procedure

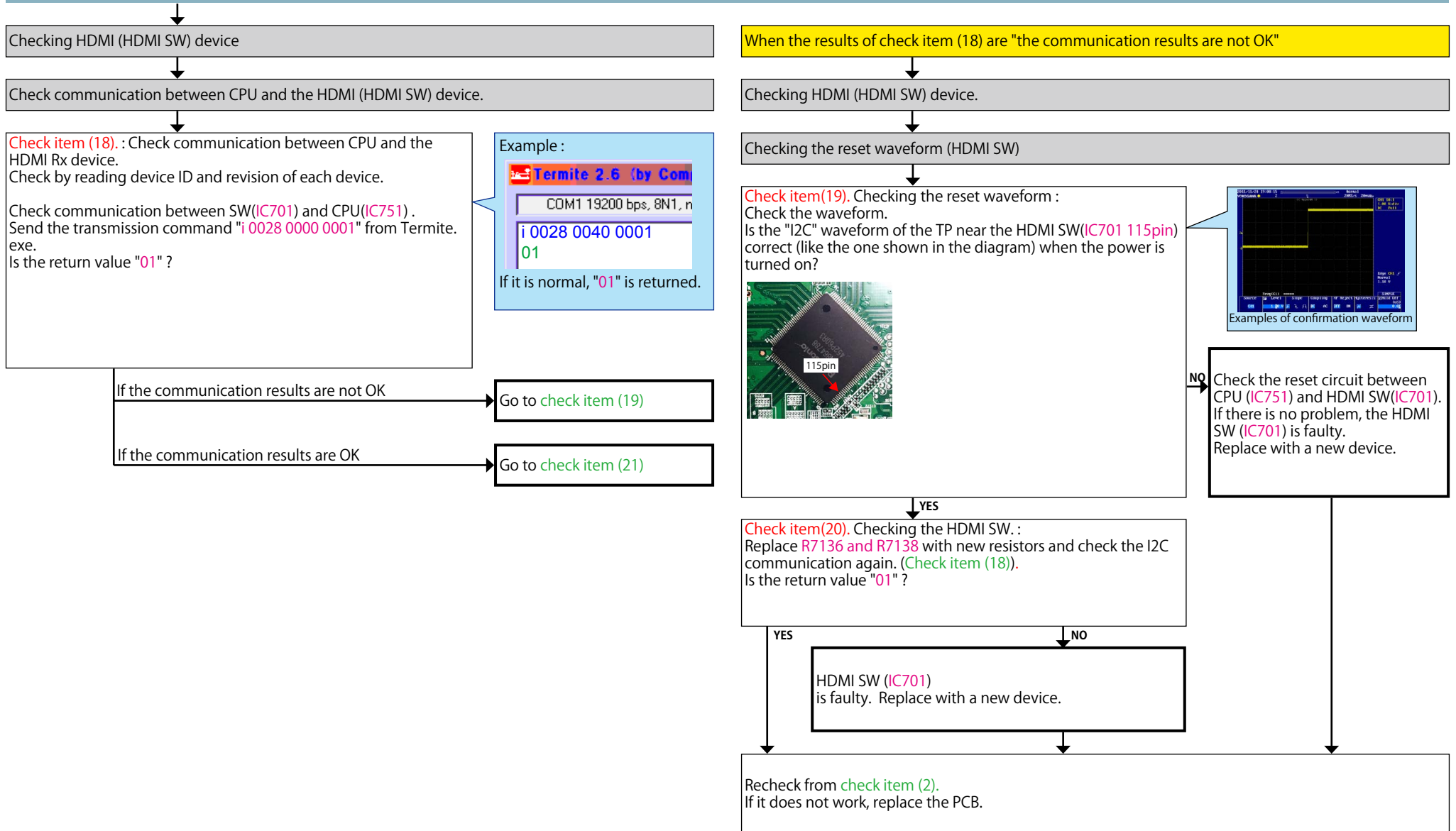

Caution in servicing

Electrical

Mechanical

Repair Information

Updating

When the results of check item (18) are "the communication results are OK"

Checking operation between the HDMI (HDMI SW) device and the player



※ In order to check, connect the player to the HDMI terminal and configure the player as AVR source. Check the sound output while turning on the player.

Checking the +5V/DDC status register (HDMI SW)

Check item(21). Checking the +5V status register :
Send the following command from Termite.exe.
Send the transmission command "i 002E 00FF 0001" from Termite.exe.
Move to the branch destination according to the value returned.

Example

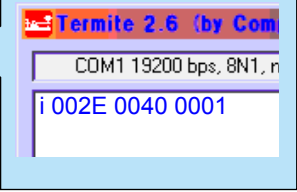

HDMI In1/In2/In3 "00"
(Detection of 5V is not OK.)

Go to **check item (23)**

HDMI In1 "44 or 40" HDMI In2 "22 or 20" HDMI In3 "11 or 10"
(Detection of 5V is OK)

Check item(22). Checking the +5V/DDC status register :
Send the following command from Termite.exe.

When the HDMI IN1, Send the transmission command "i 002B 0084 0001" from Termite.exe.

When the HDMI IN2, Send the transmission command "i 002B 0054 0001" from Termite.exe.

When the HDMI IN3, Send the transmission command "i 002B 0054 0001" from Termite.exe.

Move to the branch destination according to the value returned.

Example

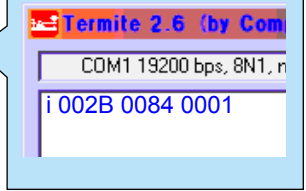

"00 or 04"
(Detection of DDC is not OK.)

Go to **check item (24)**

"22"
(Detection of DDC is OK)

Go to **check item (25)**

Caution in servicing

Electrical

Mechanical

Repair Information

Updating

When the results of check item (21) are "00"
(Detection of 5V is not OK)

Checking +5 V voltage (HDMI SW)

Check item(23). Check the +5V voltage :

Does "+5 V" at the following test point indicate 5 V? (JK701/JK711/JK721)

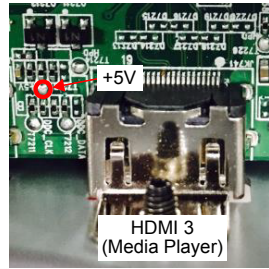
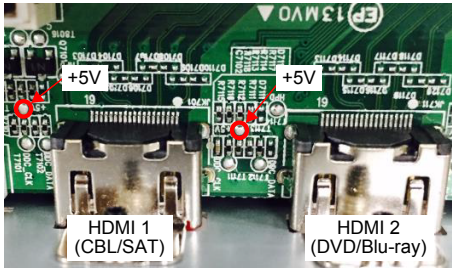

YES

NO

HDMI SW(IC701) is faulty.
Replace with a new device.

Check for a short circuit in the 5 V line and the 5 V Switch IC (IC733).
If there is no problem, the HDMI SW (IC701) is faulty.
Replace with a new device.

Recheck from check item (2).
If it does not work, replace the PCB.

When the results of check item (22) are "00 or 04"
(Detection of DDC is not OK.)

Check the DDC line (HDMI SW)

Check item(24). Check the DDC line HPD line :

Are waveforms of "DDCSCK" and "DDCSDA" observed at the test point near the HDMI input terminal(JK701/JK711/JK721)?

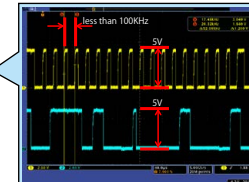
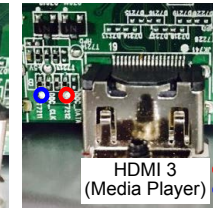
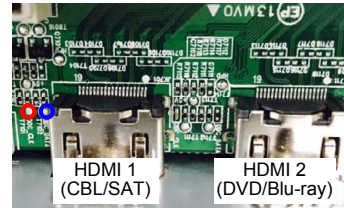

This diagram shows an example of the DDC communication waveform.
-The high level voltage is 5V.
-The frequency of the DDC CLK is 100 KHz or less.
Check at each test point.

YES

NO

HDMI SW(IC701) is faulty.
Replace with a new device.

Check for a short circuit in the DDC line.
If there is no problem, the HDMI SW (IC701) is faulty.
Replace with a new device.

Recheck from check item (2).
If it does not work, replace the PCB.

Caution in

Electrical

Mechanical

Repair Information

Updating

When the results of check item (22) are "22"
(Detection of DDC is OK.)

Checking the TMDS status register (HDMI SW)

Check item(25). Checking register of the TMDS CLK detection status register :
Send the following command from Termit.exe.
HDMI Rx/Tx
Send the transmission command "i 002E 00FF 0001" from Termit.exe.
When the following value is returned, go to Yes.
HDMI In1 "44" HDMI In2 "22" HDMI In3 "11"
When the following value is returned, go to No.
HDMI In1 "00" HDMI In2 "00" HDMI In3 "00"

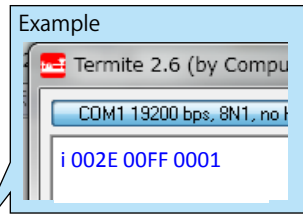

NO

Check the TMDS status of the register. (HDMI SW -> HDMI Rx/Tx)

Check item(27). Checking register of the TMDS CLK detection status register :
Send the following command from Termit.exe.
Send the transmission command "i 0006 00FF 0001" from Termit.exe.
When the following value is returned, go to Yes.
"CC or 44"
When the following value is returned, go to No.
"other"

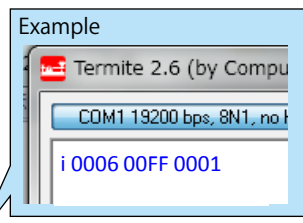

NO

Check item (28). Checking the TMDS input waveform. :
Check the TMDS waveform at the following test point.
Is the waveform like the sample?



55/56/58/59/61/62/64/65pin

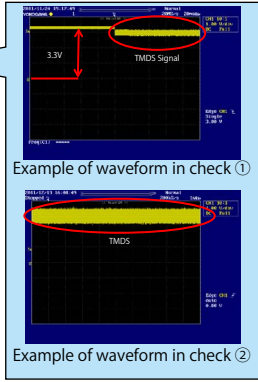

YES
The HDMI Rx/Tx (IC721) is faulty.
Replace with a new device.

NO
HDMI SW(IC701) is faulty.
Replace with a new device.

Check item (26). Checking the TMDS input waveform. :
Check the TMDS waveform at the following test point.
Is the waveform like the sample?



HDMI In3
93/94/96/97/99/100/102/103pin
HDMI In2
80/81/83/84/86/87/89/90pin
HDMI In1
55/56/58/59/61/62/64/65pin

YES
HDMI SW(IC701) is faulty.
Replace with a new device.

NO
Check for a short circuit in the pattern of the TMDS line of the HDMI SW(IC701) from the HDMI input terminal.
If there is no problem, the HDMI SW(IC701) is faulty. Replace with a new device.

Recheck from **check item (2)**.
If it does not work, replace the PCB.

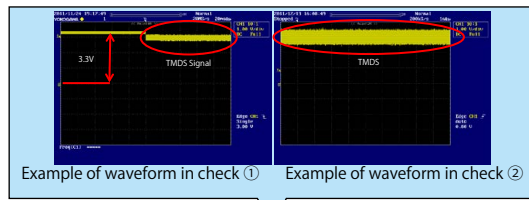

3-4 Front HDMI Buffer IC (AD8195) failure detection procedure

Checking operation between the HDMI (Front HDMI Buffer) and the player



※ In order to check, connect the player to the HDMI terminal and configure the player as AVR source. Check the sound output while turning on the player.

Check the power supply voltage. (HDMI Buffer)

Check item(29). Check the power supply voltage : Does the power supply voltage of the Front HDMI FFC base (CN701) indicate the correct voltage (5V)? The test points are as follows.

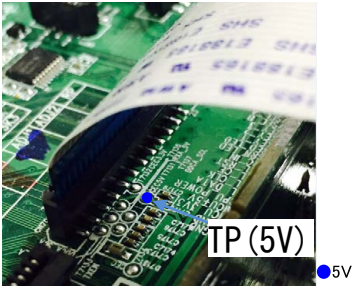
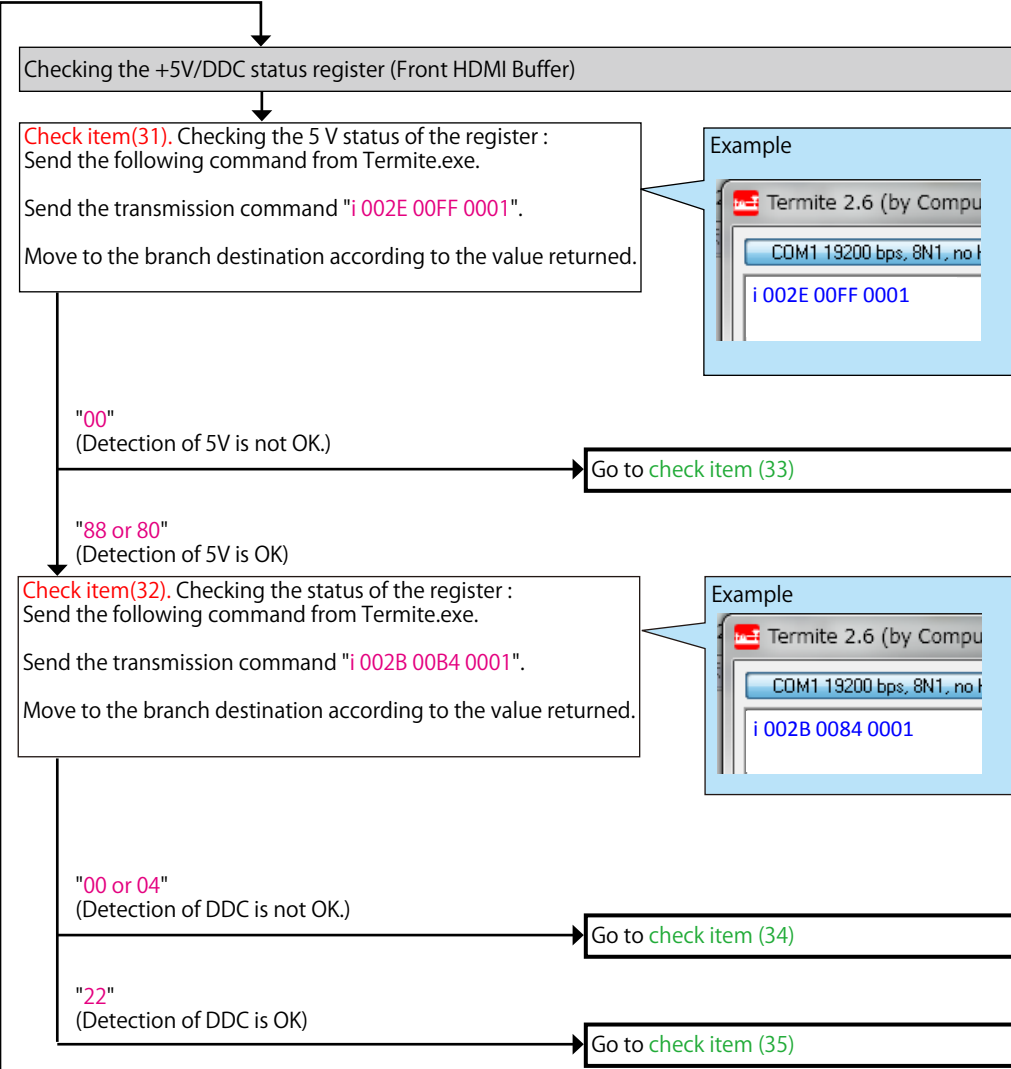
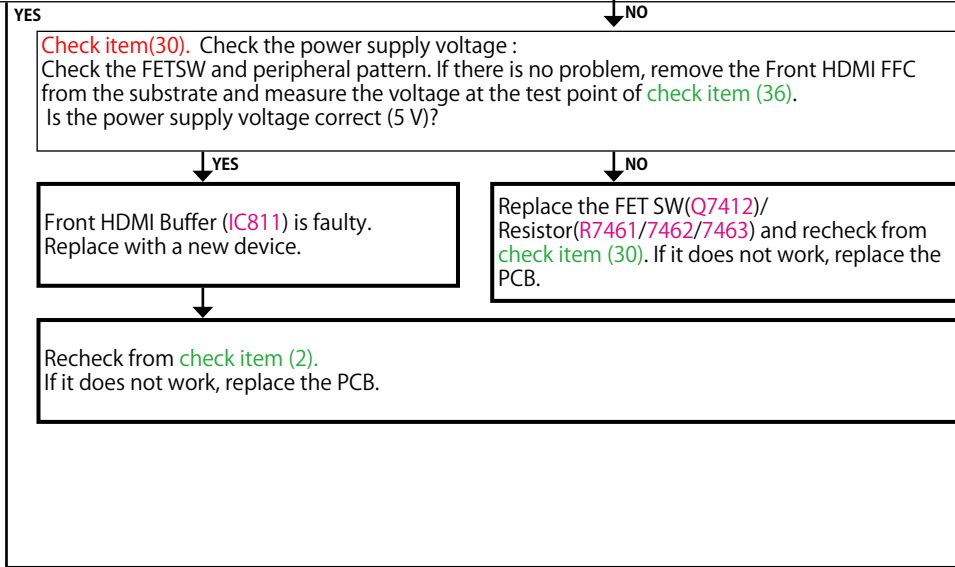
When the results of check item (31) are "00"
(Detection of 5V is not OK.)

Checking +5 V voltage (Front HDMI Buffer)

Check item(33). Check the +5V voltage :
Does "+5 V" at the following test point indicate 5 V?
The test points are as follows. (HDMI SW(IC701)

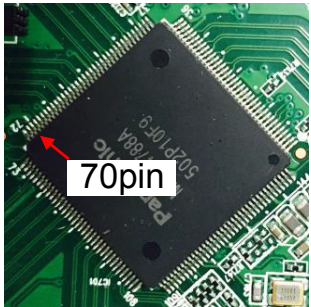

NO
Check for a short circuit in the 5 V line, the Front HDMI FFC, and the 5 V Switch (IC733).
If there is no problem, the HDMI SW1(IC701) or the 5 V Switch (IC733) is faulty.
Replace with a new device.

YES
HDMI SW(IC701) is faulty.
Replace with a new device.

Recheck from check item (2).
If it does not work, replace the PCB.

When the results of check item (32) are "00 or 04"
(If the DDC are not OK)

Checking DDC Line (Front HDMI Buffer)

Check item(34). Check the DDC line :
Does "DDCCL / DDCDA" signal of the SW(IC701) indicate 5 V?
The test points are as follows.

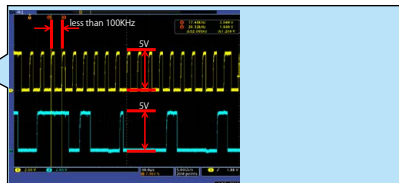
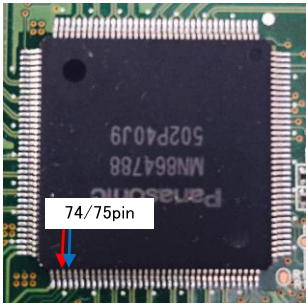

This diagram shows an example of the DDC communication waveform.
-The high level voltage is 5V.
-The frequency of the DDC CLK is 100 KHz or less.
Check at each test point.

NO
Check for a short circuit in the DDC line and check the Front HDMI FFC.
If there is no problem, the Front HDMI Buffer(IC811) is faulty.
Replace with a new device.

YES
HDMI SW(IC701) is faulty.
Replace with a new device.

Recheck from check item (2).
If it does not work, replace the PCB.

When the results of check item (32) are "22"
(Detection of DDC is OK)

Checking the TMDS status register

Check item(35). Check the TMDS CLK detection status of the register. :
Send the following command from Terminate.exe.
Send the transmission command "i 002E 00FF 0001".
The return value is "88".
Go to Yes.
The return value is "80".
Go to No.

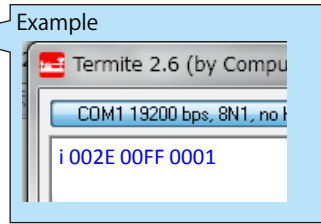

NO

Check item (36). Checking the TMDS input waveform. :
Check the TMDS waveform at the following test point.
Is the waveform like the sample?

HDMI SW(IC701)



42/43/45/46/48/49/51/52pin

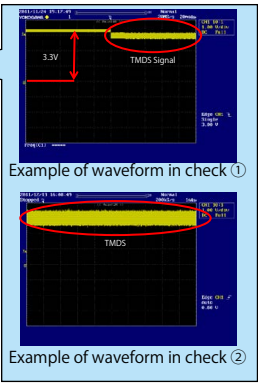

YES

HDMI SW(IC701) is faulty.
Replace with a new device.

YES

HDMI SW(IC701) is faulty.
Replace with a new device.

NO

Check for a short circuit in the TMDS line and the Front HDMI FFC.
If there is no problem, the Front HDMI Buffer(IC811) is faulty.
Replace with a new device.

Recheck from **check item (2)**.
If it does not work, replace the PCB.

3-5 OSD(ADV7623) failure detection procedure

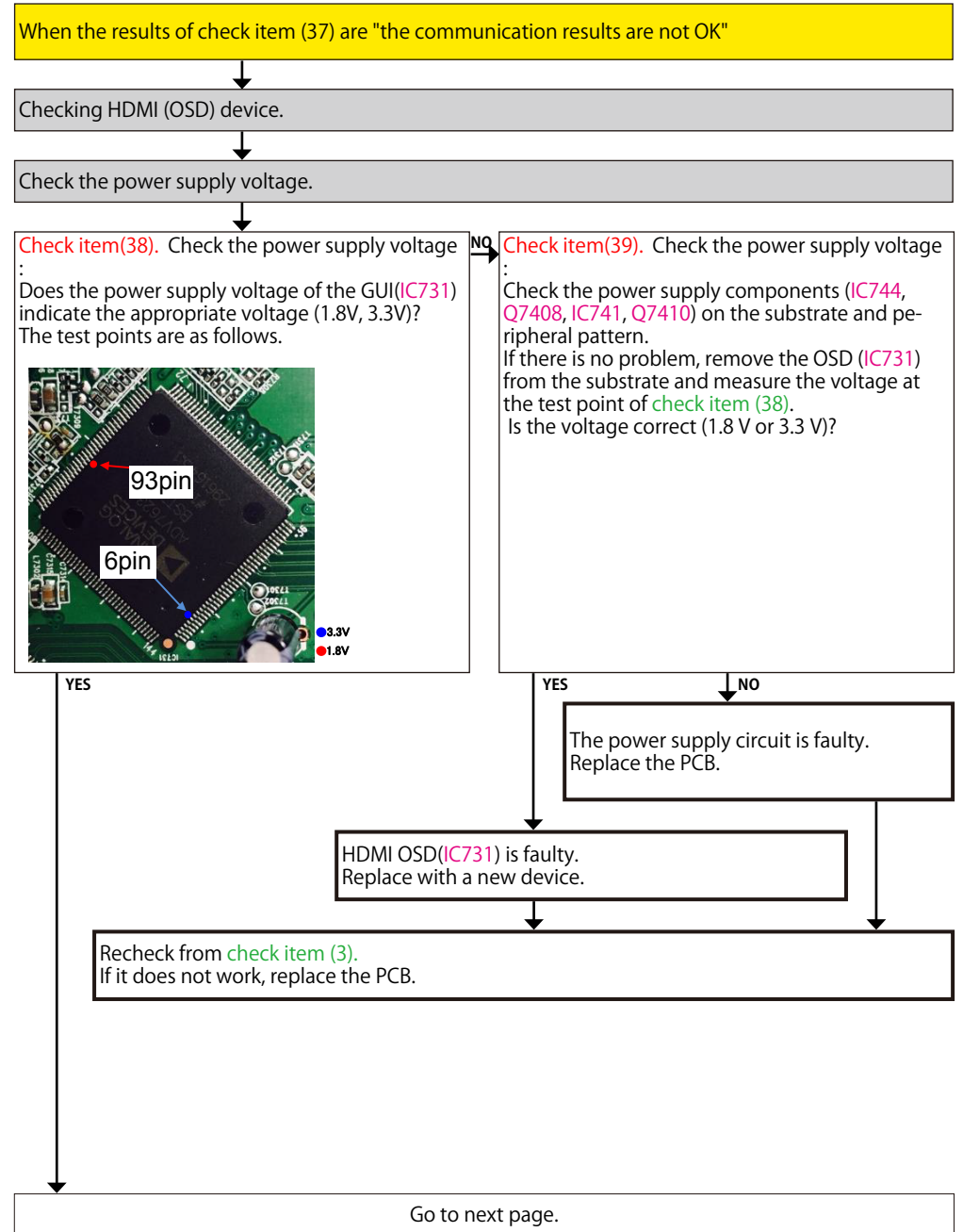
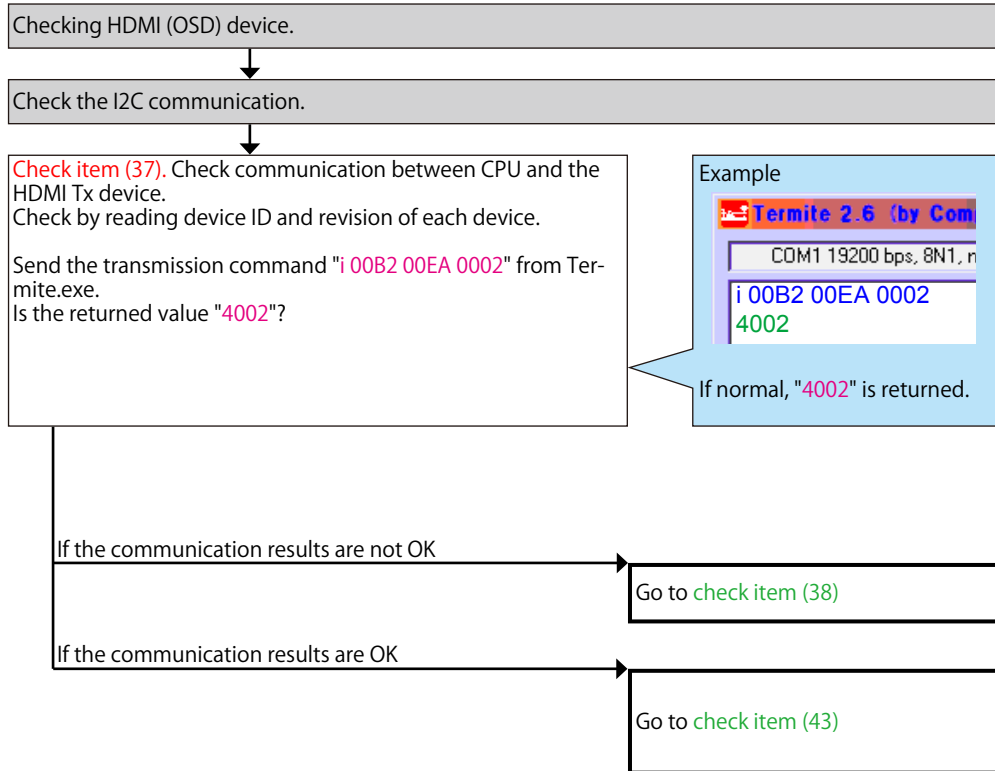

Caution in servicing

Electrical

Mechanical

Repair Information

Updating

Checking the reset waveform.

Check item(40). Checking the reset. :
Check the CPU.
Is the waveform of the TP near the OSD(IC731)97pin correct (like the one shown in the diagram) when the power is turned on?

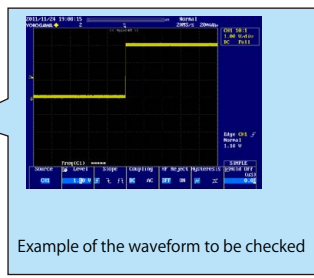
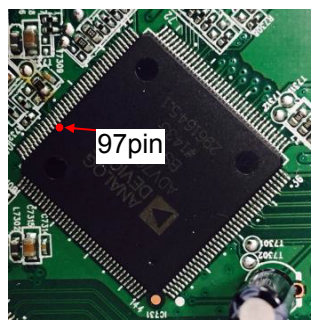

YES NO

Check the reset circuit between CPU (IC751) and HDMI OSD(IC731).
If there is no problem, the HDMI OSD (IC731) is faulty.
Replace with a new device.

Recheck from **check item (3)**.
If it does not work, replace the PCB.

Check the I2C communication line.

YES

Check item(41). Check the I2C communication line :
Check the CPU.
Is the "I2C" waveform of the TP near the HDMI OSD(IC731) correct (like the one shown in the diagram) when the power is turned on?

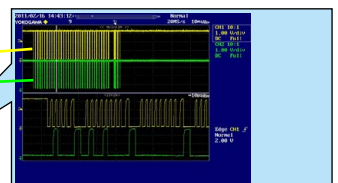
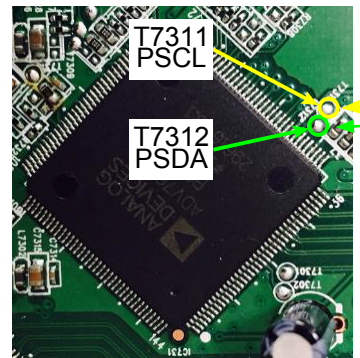

*The diagram shows an example.
(Signal patterns vary depending on the timing.)
Points for checking waveforms
- Crest value (3.3 V normally)
- Signal change
- SCL frequency (400 kHz normally)

YES NO

Check item(42). Check the I2C communication line :
Check OSD (IC731) and CPU(IC751) patterns as well as soldering.
If there is no problem, go to the next step.

Checking the HDMI Rx.
Remove the damping resistor R7324/R7325 of IC731.
Is the "I2C" waveform correct?

NO The CPU(IC751) is faulty. Replace with a new device.

YES
The OSD(IC731) is faulty.
Replace with a new device.

Recheck from **check item (3)**.
If it does not work, replace the PCB.

When the results of check item (46) are "the communication results are OK"

Check the TMDS status of the register. (OSD -> HDMI Rx/Tx)

Check item(43). Check the TMDS CLK detection status of the register. :
Send the following command from Termit.exe.
Send the transmission command "i 0006 00FF 0001".
The return value is "C8"
Go to Yes.
The return value is "other"
Go to No.

Example

Check item (44). Checking the TMDS input waveform. :
Check the TMDS waveform at the following test point.
Is the waveform like the sample?
HDMI SW(IC701)

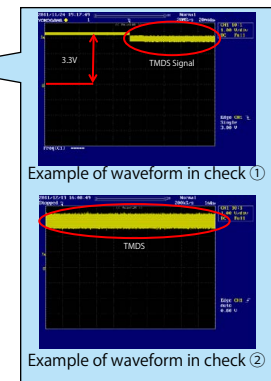
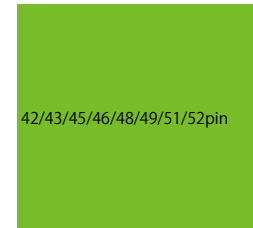

YES
Check the connection between the HDMI OUT terminal and the TV.
Go to **check item (45)**.

NO
The HDMI Rx/Tx (IC721) is faulty.
Replace with a new device.

NO
The OSD(IC731) is faulty.
Replace with a new device.

Recheck from **check item (3)**.
If it does not work, replace the PCB.

Caution in servicing

Electrical

Mechanical

Repair Information

Updating

Check the connection between the HDMI OUT terminal and the TV.
Connect the HDMI OUT terminal and the TV, and then turn on the TV and check the following items.

Check the HPD and RXSENSE register value of the HDMI TX device (Monitor).

Check item(45). Check the HPD and RXSENSE register value of the HDMI TX device. :
Send the transmission command "i 0000 0040 0001" from Termite.
exe.
Check the value.
Move to the branch destination according to the value returned.

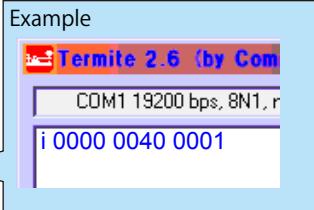

"30"
(Detection of HPD is OK / Detection of RXSENSE is OK)

Go to **check item (46)**

"10"
(Detection of HPD is OK / Detection of RXSENSE is not OK)

Go to **check item (49)**

"20"
(Detection of HPD is not OK / Detection of RXSENSE is OK)

Go to **check item (50)**

"00"
(Detection of HPD is not OK / Detection of RXSENSE is not OK)

Go to **check item (51)**

When the results of check item (45) are "30"
(Detection of HPD is OK / Detection of RXSENSE is OK)

Checking the EDID register (Monitor)

Check item(46). Check the Monitor EDID :
 ① Unplug the AC cord. Plug the AC cord into a power outlet.
 ② Send the transmission command "m_1" from Termite.exe.
 Are the first eight bytes of the returned value "00FFFFFFF00"?

Example

```

COM1 19200 bps, 8N1, no handshake
m_1
00FFFFFFF00000b1177945540000
32131010380151E782E6085A6564A9C25
125054A56B08180810081C0A9C08140
D1C061C0B300023A801871382D40582C
4500132B2100001E000000FF00394339
    
```

The first eight bytes are normally "00FFFFFFF00".
 *If the AVR and the TV are not connected via HDMI, the correct register value cannot be verified.

YES

NO

Check item(47). Checking the TMDS. :
 Check the TMDS waveform at the following test point.

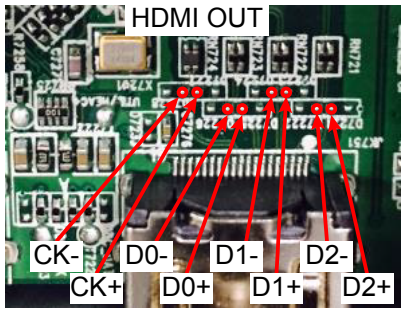

YES

NO

Check for a short circuit in the TMDS line.
 If there is no problem, the HDMI Rx/Tx (IC721) is faulty.
 Replace with a new device.

The HDMI Rx/Tx (IC721) is faulty.
 Replace with a new device.

Check item(48). Check communication with the monitor :
 Are waveforms of "DDCSCK" and "DDCSDA" observed at the test point near the HDMI output terminal(JK751)?

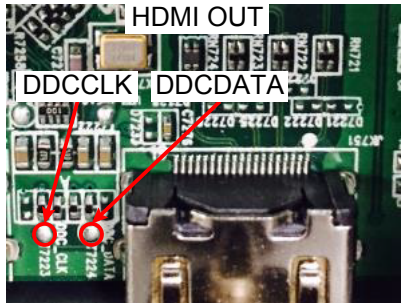

YES

NO

The HDMI Rx/Tx (IC721) is faulty.
 Replace with a new device.

The HDMI Rx/Tx (IC721) is faulty.
 Replace with a new device.

This diagram shows an example of the DDC communication waveform.
 -The high level voltage is 5V.
 -The frequency of the DDC CLK is 100 KHz or less.
 Check at each test point.

Recheck from **check item (3)**.
 If it does not work, replace the PCB.

When the results of check item (45) are "10"
(Detection of HPD is OK / Detection of RXSENSE is not OK)

Checking the RXSENSE (Monitor)

Check item(49). Checking the RXSENSE. :
Does the test point of RXSENSE close to the HDMI output terminal (JK751) indicate the 3.3 V?

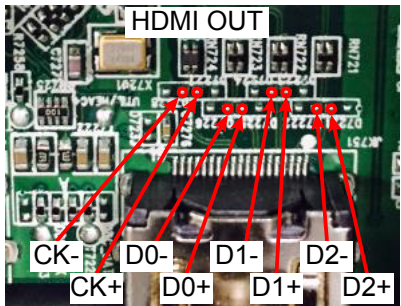

YES NO

Check for a short circuit in the TMDS line.
If there is no problem, the HDMI Rx/Tx (IC721) is faulty.
Replace with a new device.

The HDMI Rx/Tx (IC721) is faulty.
Replace with a new device.

Recheck from **check item (3)**.
If it does not work, replace the PCB.

When the results of check item (45) are "20"
(Detection of HPD is not OK / Detection of RXSENSE is OK)

Checking the HPD. (Monitor)

Check item(50). Checking the HPD. :
Does the voltage of HPD test point close to the HDMI output terminal (JK751) indicate Hi (3-5 V)?

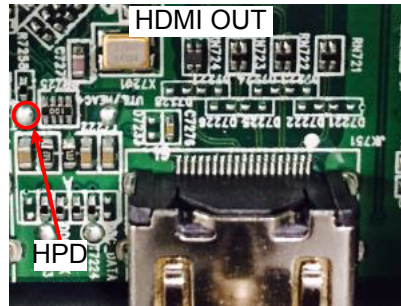

YES NO

Check for a short circuit in the HPD line.
If there is no problem, the HDMI Rx/Tx (IC721) is faulty.
Replace with a new device.

The HDMI Rx/Tx (IC721) is faulty.
Replace with a new device.

Recheck from **check item (3)**.
If it does not work, replace the PCB.

When the results of check item (45) are "00"
(Detection of HPD is not OK / Detection of RXSENSE is not OK)

Checking the RXSENSE/HPD. (Monitor)

Check item(51). Checking the HPD and RXSENSE. :
Does the test point of RXSENSE close to the HDMI output terminal (JK751) indicate the 3.3 V?
Does the voltage of HPD test point close to the HDMI output terminal (JK751) indicate Hi (3-5 V)?

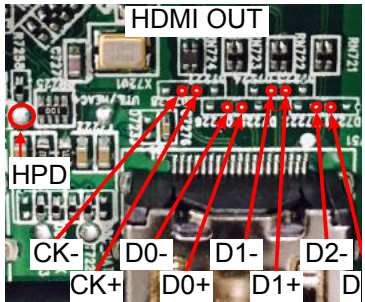

YES NO

Check for a short circuit in the TMDS/ HPD line.
If there is no problem, the HDMI Rx/Tx (IC721) is faulty.
Replace with a new device.

The HDMI Rx/Tx (IC721) is faulty.
Replace with a new device.

Recheck from check item (3).
If it does not work, replace the PCB.

3-6 HDMI Rx/Tx(MN864788) & OSD(ADV7623) failure detection procedure

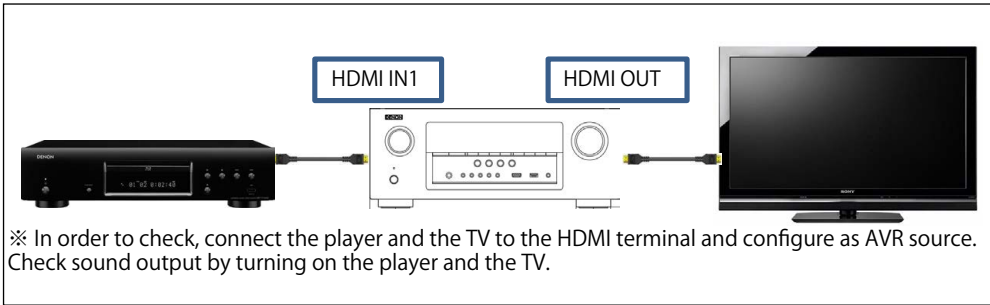

Checking the TMDS status of the register. (Rx/Tx -> OSD)

Check item(52). Check the TMDS CLK detection status of the register.
Send the following command from Termit.exe.
Send the transmission command "i 00B2 006A 0001".
The return value is "11".
Go to Yes.
The return value is "00".
Go to No.

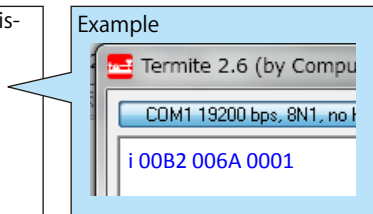

Check item (53). Checking the TMDS input waveform. :
Check the TMDS waveform at the following test point.
Is the waveform like the sample?

23/24/26/27/29/30/32/33 pin

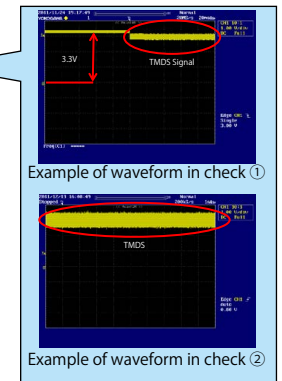

Please check between Monitor Out and TV
Replace with a new device.

The HDMI Rx/Tx (IC721) is faulty.
Replace with a new device.

The OSD(IC731) is faulty.
Replace with a new device.

Recheck from **check item (4)**.
If it does not work, replace the PCB.

Caution in servicing

Electrical

Mechanical

Repair Information

Updating

4. Device implementation location

HDMI PCB

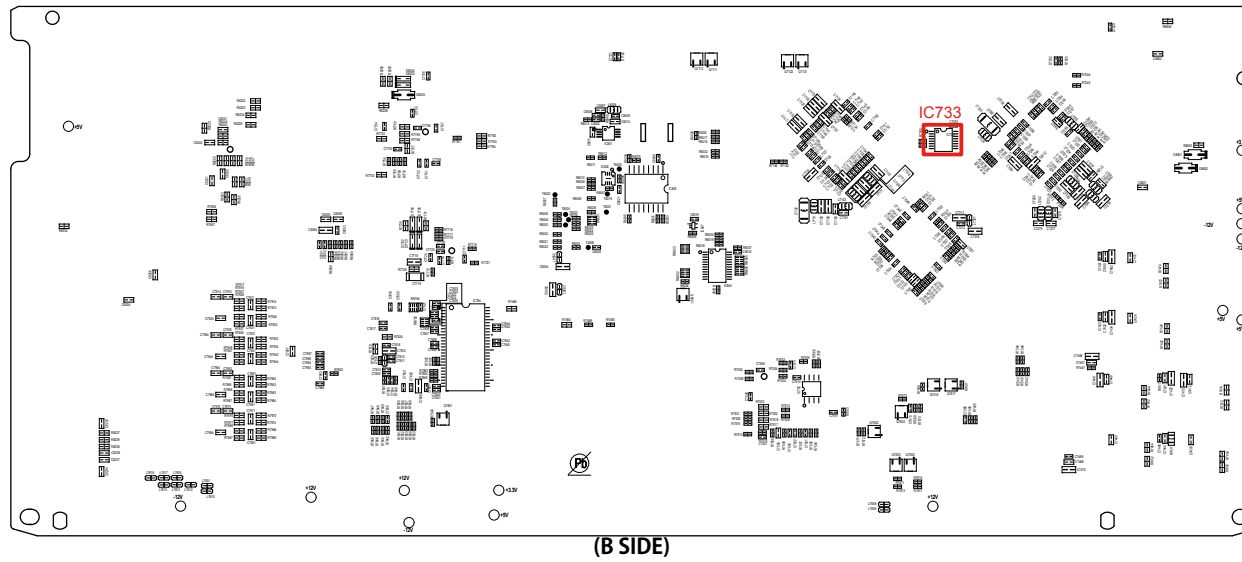
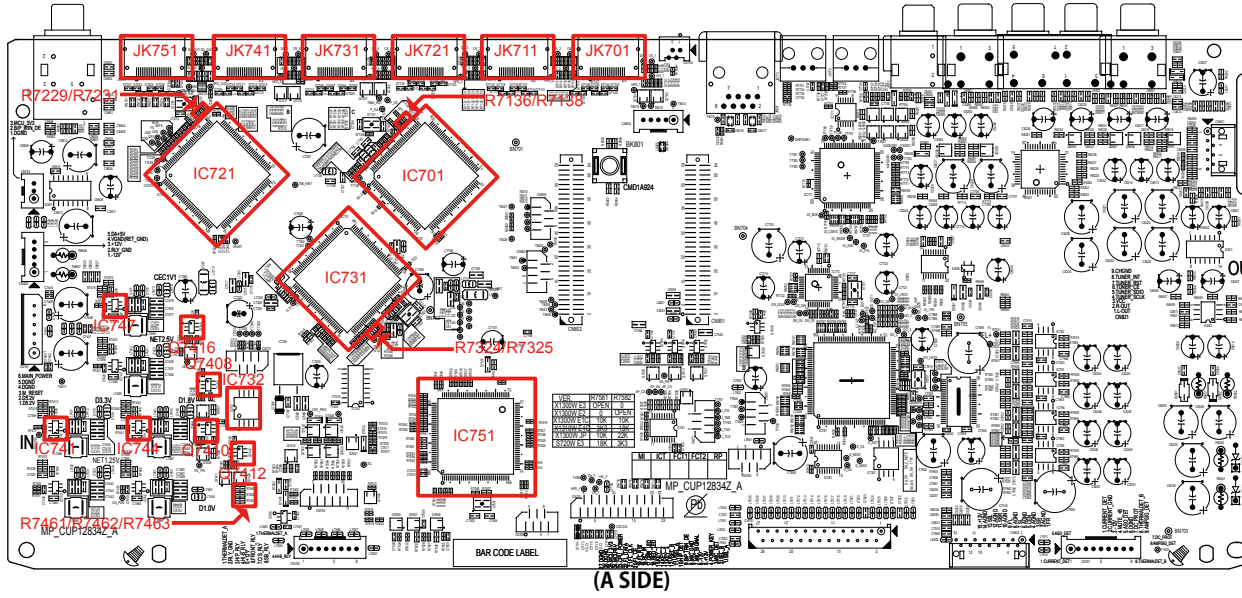

F-HDMI PCB

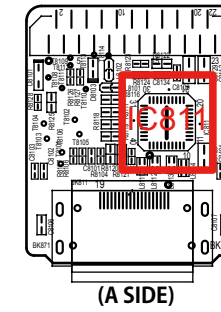

Caution in servicing

Electrical

Mechanical

Repair Information

Updating

CLOCK FLOW & WAVE FORM IN DIGITAL BLOCK

WAVE FORM

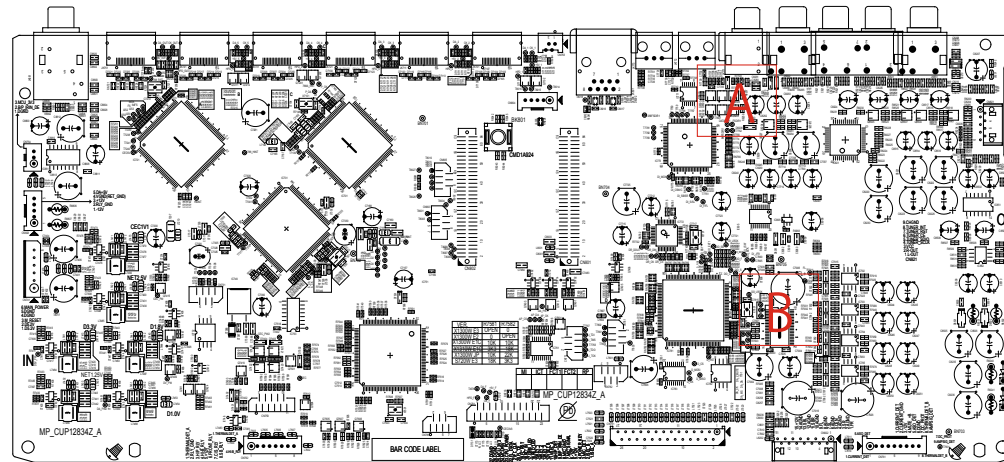
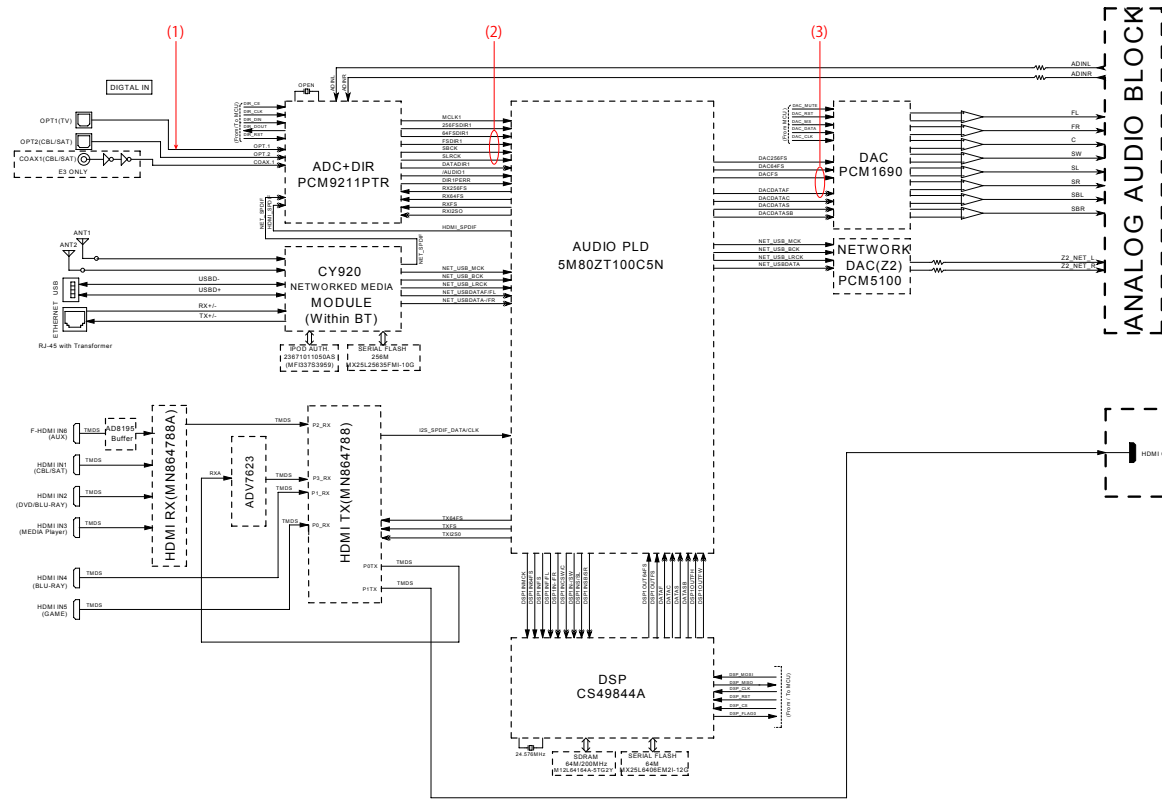
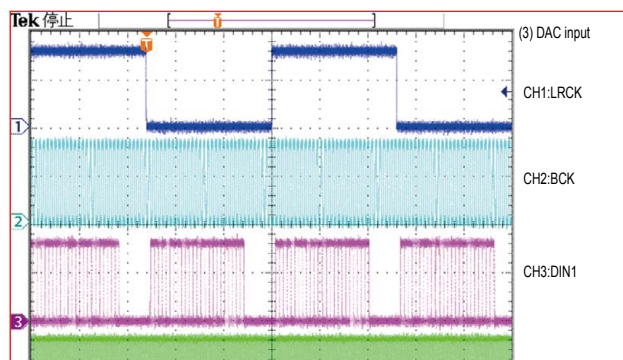
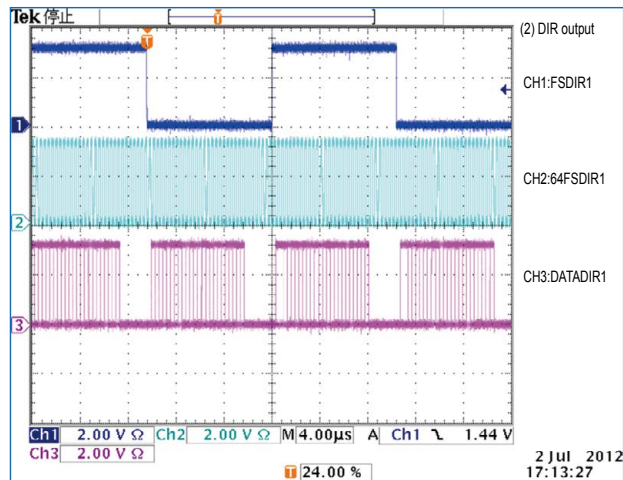
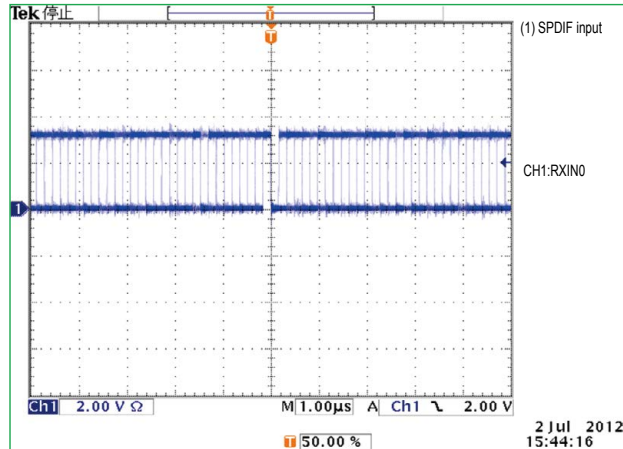

Detail A

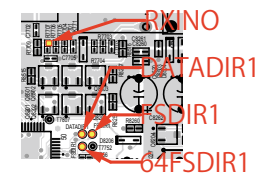

Detail B

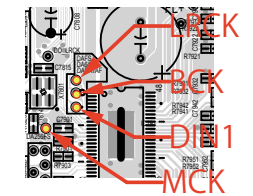

Caution in servicing

Electrical

Mechanical

Repair Information

Updating

SPECIAL MODE

Special mode setting button **AVR-X1300W**

※ No. 1 - 8 : While holding down buttons "A", "B" and "C" simultaneously, press the power button to turn on the power.

※ No. 9 : While holding down buttons "A", "B" and "C" simultaneously, insert the AC plug into the wall outlet to turn on the power.

No.	Mode	Button A	Button B	Button C	Descriptions
1	Version Display (u-COM / DSP Error Display)	DIMMER	STATUS	-	Displays the version of firmware such as the main firmware or DSP. Errors that have occurred are displayed. (See 1. Version Display Mode)
2	PANEL / REMOTE LOCK Selection Mode	TUNER PRESET CH +	ZONE2 SOURCE	-	Start this unit in the PANEL/REMOTE LOCK selection mode so that PANEL LOCK and Remote Lock can be switched between On and Off. (See 2. PANEL / REMOTE LOCK Selection Mode) PANEL LOCK MODE : No. 2 - 1 - No. 2 - 3
2-1	PANEL LOCK Mode (with Volume)	↑	↑	-	Disables reception from all keys and encoders on the front panel except the power button (including the volume).
2-2	PANEL LOCK Mode (without Volume)	↑	↑	-	Disables reception from all keys and encoders on the front panel except the power button and volume encoder.
2-3	PANEL LOCK mode is turned off	↑	↑	-	Releases the PANEL LOCK.
3	Selecting the Mode for Service-related	ZONE2 SOURCE	DIMMER	STATUS	This is a display for turning on each service-related mode. Service-related modes: No. 3-1 - No. 3-5 (See 3-1. Selecting the Mode for Service-related)
3-1	Check the Video/Audio path Mode	↑	↑	↑	This is a special mode for service confirmation used during repair work to simplify the confirmation work for the Audio channel / video channel. (See DIAGNOSTIC MODE)
3-2	Protection history display mode	↑	↑	↑	Displays the protection occurrence history. (See 3-2. Protection History Display Mode)
3-3	Operation Info Mode	↑	↑	↑	Displays the accumulated operating time of the unit, the number of times the power was switched on, and the number of occurrences of each protection. (See 3-3. Operation Info Mode)
3-4	TUNER STEP Mode (E3 and E2 model only)	↑	↑	↑	Enables reception STEP of the ANALOG TUNER to be changed. (See 3-4. TUNER STEP mode (E2 / E3 only))
3-5	Remote ID Setup Mode	↑	↑	↑	If there are multiple DENON AV receivers in the same area, this mode prevents other AV receivers from being operated concurrently with this device. (See 3-5. Remote ID Setup Mode)
4	Protection Pass Mode	TUNER PRESET CH +	ZONE2 SOURCE	STATUS	Enables the power to be turned on when protection detection is disabled. (See 4. Protection Pass Mode)
5	User Initialization Mode	TUNER PRESET CH -	TUNER PRESET CH +	-	Initializes backup data. (Settings for the Installer Setup are not initialized) (Reboot the CY920)
6	Factory Initialization Mode	ZONE2 SOURCE	DIMMER	-	Initializes backup data. (Settings for the Installer Setup are initialized) (CY920 is not Reboot) (See CAUTION IN SERVICING.)
7	Clearing the Operation Info	ZONE2 SOURCE	STATUS	-	Clear the accumulated operating time of the unit, the number of times the power was switched on, and the number of occurrences of each protection. (See 7. Clearing the Operation Info)
8	USB Update mode	TUNER PRESET CH +	STATUS	-	Switches this unit to USB Update mode. (See 2. Updating via USB)
9	Forced USB All Device Write Mode	TUNER PRESET CH +	STATUS	-	Mode used when this unit cannot be recovered. Forcibly switches this unit to USB update mode. (See 2.9. Forced USB All Device Write Mode)

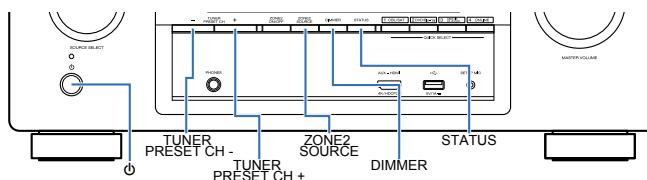

Special mode setting button AVR-S720W

※ No. 1 - 8 : While holding down buttons "A", "B" and "C" simultaneously, press the power button to turn on the power.

※ No. 9 : While holding down buttons "A", "B" and "C" simultaneously, insert the AC plug into the wall outlet to turn on the power.

No.	Mode	Button A	Button B	Button C	Descriptions
1	Version Display (u-COM / DSP Error Display)	DIMMER	STATUS	-	Displays the version of firmware such as the main firmware or DSP. Errors that have occurred are displayed. (See 1. Version Display Mode)
2	PANEL / REMOTE LOCK Selection Mode	ZONE2 SOURCE	TUNER PRESET CH +	-	Start this unit in the PANEL/REMOTE LOCK selection mode so that PANEL LOCK and Remote Lock can be switched between On and Off. (See 2. PANEL / REMOTE LOCK Selection Mode) PANEL LOCK MODE : No. 2 - 1 - No. 2 - 3
2-1	PANEL LOCK Mode (with Volume)	↑	↑	-	Disables reception from all keys and encoders on the front panel except the power button (including the volume).
2-2	PANEL LOCK Mode (without Volume)	↑	↑	-	Disables reception from all keys and encoders on the front panel except the power button and volume encoder.
2-3	PANEL LOCK mode is turned off	↑	↑	-	Releases the PANEL LOCK.
3	Selecting the Mode for Service-related	TUNER PRESET CH +	TUNE -	TUNE +	This is a display for turning on each service-related mode. Service-related modes: No. 3-1 - No. 3-5 (See 3-1. Selecting the Mode for Service-related)
3-1	Check the Video/Audio path Mode	↑	↑	↑	This is a special mode for service confirmation used during repair work to simplify the confirmation work for the Audio channel / video channel. (See DIAGNOSTIC MODE)
3-2	Protection history display mode	↑	↑	↑	Displays the protection occurrence history. (See 3-2. Protection History Display Mode)
3-3	Operation Info Mode	↑	↑	↑	Displays the accumulated operating time of the unit, the number of times the power was switched on, and the number of occurrences of each protection. (See 3-3. Operation Info Mode)
3-4	TUNER STEP Mode (E3 and E2 model only)	↑	↑	↑	Enables reception STEP of the ANALOG TUNER to be changed. (See 3-4. TUNER STEP mode (E2 / E3 only))
3-5	Remote ID Setup Mode	↑	↑	↑	If there are multiple DENON AV receivers in the same area, this mode prevents other AV receivers from being operated concurrently with this device. (See 3-5. Remote ID Setup Mode)
4	Protection Pass Mode	ZONE2 SOURCE	TUNER PRESET CH +	TUNE +	Enables the power to be turned on when protection detection is disabled. (See 4. Protection Pass Mode)
5	User Initialization Mode	TUNER PRESET CH -	TUNER PRESET CH +	-	Initializes backup data. (Settings for the Installer Setup are not initialized) (Reboot the CY920)
6	Factory Initialization Mode	TUNER PRESET CH +	TUNE -	-	Initializes backup data. (Settings for the Installer Setup are initialized) (CY920 is not Reboot) (See CAUTION IN SERVICING.)
7	Clearing the Operation Info	TUNER PRESET CH +	TUNE +	-	Clear the accumulated operating time of the unit, the number of times the power was switched on, and the number of occurrences of each protection. (See 7. Clearing the Operation Info)
8	USB Update mode	ZONE2 SOURCE	TUNE +	-	Switches this unit to USB Update mode. (See 2. Updating via USB)
9	Forced USB All Device Write Mode	ZONE2 SOURCE	TUNE +	-	Mode used when this unit cannot be recovered. Forcibly switches this unit to USB update mode. (See 2.9. Forced USB All Device Write Mode)

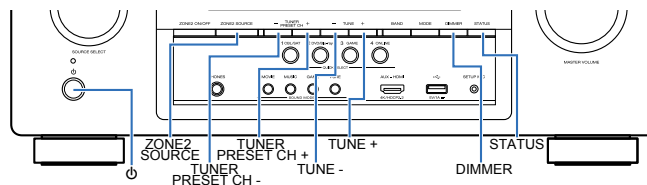

1. Version Display Mode

1.1. Actions

Version information is displayed when the device is started in this mode.

1.2. Starting up

While holding down buttons "DIMMER" and "STATUS" simultaneously, press the power button to turn on the power.

then press the "STATUS" button to display the information in section 1.3 on the display.

※ The version list is also displayed on GUI while the version is displayed on the display.

1.3. Display Order

Error information (See "1.4. Error display") → ① Model destination information → ② Firmware Package → ③ Main μ -com → ④ Main 1st Boot Loader → ⑤ DSP ROM → ⑥ Audio PLD → ⑦ GUI SFLASH → ⑧ Ethernet 1st Boot Loader, Hardware ID → ⑨ Ethernet 2nd Boot Loader, Rhapsody Flag → ⑩ Ethernet IMAGE → ⑪ Network MAC ADDRESS information → ⑫ Bluetooth MAC Address information

① Model destination information :

```
AVR-S720W E3 *
```

```
AVR-X1300W \ \ *
```

\ : Region (E3, E2, E1C, JP)

② Firmware Package :

```
Package !****
```

③ Main μ -com :

```
Main !%%##*
```

% : Main version, # : Sub version

④ Main 1st Boot Loader :

```
Main FBL !**.**
```

⑤ DSP ROM :

```
DSP !**.**
```

⑥ Audio PLD :

```
Audio PLD!**.**
```

⑦ GUI SFLASH :

```
GUI !00$\****
```

0 : Model code, # : Brand code (DENON=1),

\ : Region code (E3=1, E2=2, E1C=5, JP=4, ALL=0), * : version

⑧ Ethernet 1st Boot Loader, Hardware ID :

```
Ethernet FBL
```

↓ Press "STATUS" button.

```
*****-**
```

⑨ Ethernet 2nd Boot Loader, Rhapsody Flag :

```
Ethernet SBL
```

↓ Press "STATUS" button.

```
B*****-0A
```

⑩ Ethernet IMAGE :

```
Ethernet IMG
```

↓ Press "STATUS" button.

```
I*****
```

⑪ Network MAC ADDRESS information :

```
*NET MAC Address
```

↓ Press "STATUS" button.

```
*****-*****
```

⑫ Bluetooth MAC ADDRESS information :

```
*BT MAC Address
```

↓ Press "STATUS" button.











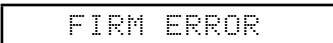

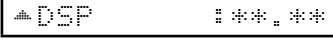
```
*****-*****
```

1.4. Error display

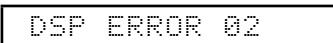
See the table below for descriptions of the displayed errors and countermeasures for these.

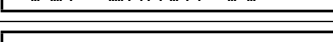
If multiple errors occur, only one item is displayed.

The priority order is ②, ③, ④, ①.

Condition	States	Display	TROUBLE SHOOTING
① Firm Check NG	The model name, brand name and region information written in the firmware are compared to the region settings in the PCB. This error is displayed if the information does not match. "▲" is displayed as the first character if the firmware is not correct (see the illustrations on the right).	    	<ul style="list-style-type: none"> •Check the resistor for setting the region (R7581 / 7582,DIGITAL PCB). •Write the firmware for the correct region.
② DIR NG	This error is displayed if there is no response from the DIR.		<ul style="list-style-type: none"> •Check the DIR (IC772, DIGITAL PCB) and surrounding circuits.
③ DSP NG	The DSP FLAG0 port does not enter "Hi" status while booting a DSP code even after resetting DSP.		<ul style="list-style-type: none"> •Check the DSP (IC781, DIGITAL PCB) and surrounding circuits.
	The DSP FLAG0 port does not enter "Hi" status before issuing a DSP command.		
	Setting WRITE to "Lo" does not set ACK to "Hi" during DSP data reading.		
	Setting REQ to "Lo" does not set ACK to "Lo" during DSP data reading.		
	Setting WRITE to "Hi" does not set ACK to "Hi" during DSP data writing.		
Setting REQ to "Lo" does not set ACK to "Lo" during DSP data writing.			
④ EEPROM NG	An error occurred in a checksum of the EEPROM(*** is a block address number).		

1.5. Version Display in the Setup Menu

Follow the steps below to display the firmware information.

- (1) Press the "SETUP" button on the remote control.
- (2) Select "General - Information - Firmware".

The version information is displayed as a 12-digit number as shown in the screen shot below.



GUI Image

This 12-digit number comprises a part of the version number of each device and module. These version numbers correspond to the 14-digit number as shown below.

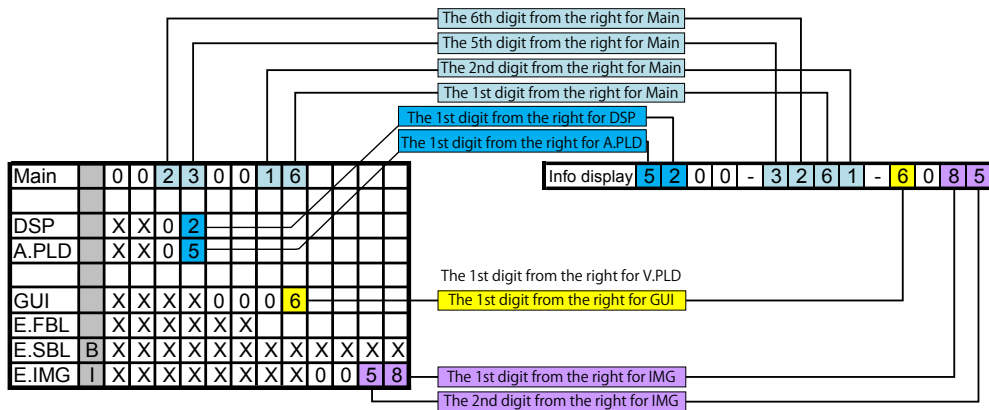

※ The firmware version numbers and this 12-digit version information are written in the Service Information.

2. PANEL / REMOTE LOCK Selection Mode

2.1. Actions

Switch the PANEL LOCK and REMOTE LOCK modes between on and off.

2.2. Starting up

While holding down buttons "TUNER PRESET CH+" and "ZONE2 SOURCE" simultaneously, press the power button to turn on the power.

Select the desired mode using the "TUNER PRESET CH+" button, then press the "STATUS" button to confirm.

2.3. Displaying and Selecting Each Mode

The information shown on the display switches each time the "TUNER PRESET CH+" button is pressed.

Press the "STATUS" button to set the currently displayed mode and restart the device.

The setting with "*" is selected for each mode.

①

FP/VOL LOCK*ON

The buttons on the unit and the master volume knob does not function.



②

FP LOCK ON

The buttons on the unit does not function.



③

FP LOCK OFF

The PANEL LOCK mode is turned off.



④

RC LOCK ON

The device cannot be operated by the remote control.



⑤

RC LOCK *OFF

The REMOTE LOCK mode is turned off.

3-1. Selecting the Mode for Service-related

3-1.1. Actions

Select diagnostic mode (service path check mode), protection history display mode, or 232C standby clear mode.

3-1.2. Starting up

AVR-X1300W

- While holding down buttons "ZONE2 SOURCE", "DIMMER" and "STATUS" simultaneously, press the power button to turn on the power.

AVR-S720W

- While holding down buttons "TUNER PRESET CH+", "TUNE -" and "TUNE +" simultaneously, press the power button to turn on the power.

Select the desired mode using the "TUNER PRESET CH+" button, then press the "STATUS" button to confirm.

3-1.3. Displaying and Selecting Each Mode

The information shown on the display switches each time the "TUNER PRESET CH+" button is pressed.

Press the "STATUS" button to set the currently displayed mode and restart the device.

①

1. SERVICE CHECK

Service Path Check Mode : See "DIAGNOSTIC MODE"

The Video and Audio paths can be checked.

This function is convenient for confirming problem paths in the product and checking the paths after repairing.



②

2. PROTECTION

The protection history can be checked.



③

4. OP INFO

Operation Info for the unit can be checked.



④

5. TUNER FRQ SET

Enables reception STEP of the ANALOG TUNER to be changed.



⑤

6. REMOTE ID

This function is for operating only the desired AV receiver.

3-1.4. Canceling the selected mode

Press the power button to turn off the power.

3-2. Protection History Display Mode

3-2.1. Actions

This mode enables the unit to record and display the event when the THERMAL, ASO or DC protection is activated.

If protections have been activated multiple times, the latest protection operation is recorded.

3-2.2. Starting up

AVR-X1300W

- While holding down buttons "ZONE2 SOURCE", "DIMMER" and "STATUS" simultaneously, press the power button to turn on the power.

AVR-S720W

- While holding down buttons "TUNER PRESET CH+", "TUNE -" and "TUNE +" simultaneously, press the power button to turn on the power.

Select the "2. PROTECTION" using the "TUNER PRESET CH+" button, then press the "STATUS" button then to confirm.

3-2.3. Protection information and displays

- Press the "STATUS" button in Protection History Display Mode.
- The protection history can be checked.

- (a) If no protections has occurred.

NO PROTECT

- (b) ASO (if the last protection is ASO)

PRT:ASO

Cause : A short circuit occurred between the speaker terminals, or speakers with an impedance outside the rating were connected.

Note : Short circuits in speaker terminals or speakers can be identified.

If the power is turned on in the abnormal state, protection is activated after around 6 seconds and the power is turned off.

- (c) DC (if the last protection is DC)

PRT:DC

Cause : DC output of the power amplifier is abnormal.

If the power is turned on in the abnormal state, protection is activated after around 6 seconds and the power is turned off.

- (d) THERMAL (if the last protection is THERMAL(A) or THERMAL(B))

PRT:THERMAL A

PRT:THERMAL B

Cause : Abnormal heat sink temperature.

If the power is turned on under abnormal conditions, the protection function works immediately and the power is turned off.

- (e) Case of CURRENT (when the last protection incident is CURRENT protection)

: CURRENT

Cause : An over current flowed in power amp.

If the power is turned on in the abnormal state, protection is activated after around 90 seconds and the power is turned off.

Caution : These protections may also be activated due to other factors such as disconnection of connectors or operations around the microcomputer.

After viewing the above protection history, press the "STATUS" button to return to the normal display.

3-2.4. Clearing the Protection History

There are two ways to clear the protection history.

- (a) Activate Protection History Display Mode. Press the "STATUS" button to display the protection history. Press and hold the "DIMMER" button for 3 seconds.

PRT:DC

Press and hold the "DIMMER" button for 3 seconds.

PRT: CLEAR

The above message is displayed and the protection history is cleared.

NO PROTECT

- (b) Initialize this unit. (See "CAUTION IN SERVICING.")

※ Use the method in 3-2.4. (a) if you do not want to erase your settings from this unit.

Warning Displays by POWER LED

If the power is turned Off while a protection is being detected, the POWER LED flashes in red to warn you depending on the protection status as follows.

- (a) ASO/DC protection: Flashes at 0.5-second intervals (0.25 seconds lit, 0.25 seconds unlit)

- (b) THERMAL (A/B) protection: Flashes at 2-second intervals (1 seconds lit, 1 seconds unlit)

- (c) CURRENT protection: Flashes at 4-second intervals (2 seconds lit, 2 seconds unlit)

3-3. Operation Info Mode

3-3.1. Actions

This mode enables the unit to display the accumulated operating time, power On count and each protection count.

3-3.2. Starting up

AVR-X1300W

- While holding down buttons "ZONE2 SOURCE", "DIMMER" and "STATUS" simultaneously, press the power button to turn on the power.

AVR-S720W

- While holding down buttons "TUNER PRESET CH+", "TUNE -" and "TUNE +" simultaneously, press the power button to turn on the power.

Select the "4. OP INFO" using the "TUNER PRESET CH+" button, then press the "STATUS" button then to confirm.

3-3.3. Operations

Press the "STATUS" button after starting up this device in Operation Info mode. The following information is displayed in the following order.

- (a) Accumulated operating time

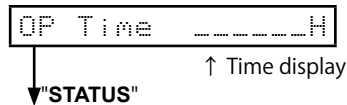

- (b) Power On count

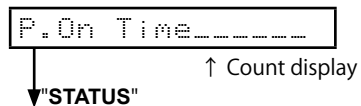

- (c) DC / ASO Protection count



- (d) Thermal Protection (A/B) count

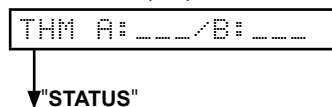

- (e) Current Protection count

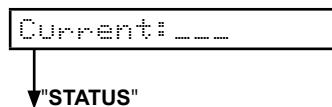

(Returns to normal display)

3-4. TUNER STEP mode (E2 / E3 only)

3-4.1. Actions

This is a special mode for enabling reception STEP of the ANALOG TUNER to be changed.

3-4.2. Starting up

AVR-X1300W

- While holding down buttons "ZONE2 SOURCE", "DIMMER" and "STATUS" simultaneously, press the power button to turn on the power.

AVR-S720W

- While holding down buttons "TUNER PRESET CH+", "TUNE -" and "TUNE +" simultaneously, press the power button to turn on the power.

Select the "5. TUNER FRQ SET" using the "TUNER PRESET CH+" button, then press the "STATUS" button then to confirm.

3-4.3. Displays

Start up this unit in TUNER STEP mode, select the desired option using the "TUNER PRESET CH+/-" button, then enter using the "STATUS" button.

The following information is displayed in the following order.

- (a) AM9 kHz / FM50 kHz is selected

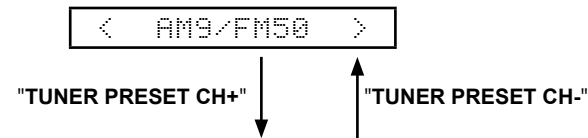

- (b) AM10 kHz / FM200 kHz is selected



- (c) Press the power button to turn off the power.

- (d) Press the power button to turn on the power.

3-5. Remote ID Setup Mode

3-5.1. Actions

This function allows only the desired AV receiver to be operated if multiple DENON AV receivers are used in the same room.

3-5.2. Starting up

AVR-X1300W

- While holding down buttons "ZONE2 SOURCE", "DIMMER" and "STATUS" simultaneously, press the power button to turn on the power.

AVR-S720W

- While holding down buttons "TUNER PRESET CH+", "TUNE -" and "TUNE +" simultaneously, press the power button to turn on the power.

Select the "6. REMOTE ID" using the "TUNER PRESET CH+" button, then press the "STATUS" button then to confirm.

3-5.3. Operations

- (a) When Remote ID Setup mode is activated, the following message is displayed.



REMOTE ID ?

- (b) Press the desired "QUICK SELECT 1 - 4" button.

Button	Display
QUICK SELECT 1	REMOTE ID 1
QUICK SELECT 2	REMOTE ID 2
QUICK SELECT 3	REMOTE ID 3
QUICK SELECT 4	REMOTE ID 4

- (c) Press the power button to turn off the power.

- (d) Press the power button to turn on the power.

※ Only "QUICK SELECT 1 - 4" and the POWER button on the unit can be used in Remote ID Setup Mode.

※ The remote ID of the remote control supplied with this unit cannot be changed.

NOTE :

If the ID of the unit and remote control do not match, "AVAMP*" appears on the display of the unit when the remote control is used

(* : own remote control ID).

4. Protection Pass Mode

4.1. Actions

- This mode allows the power to be turned on without activating protections.
- This mode functions in the same way as normal power-on, except that protections are not activated.

4.2. Operations

AVR-X1300W

- While holding down buttons "**TUNER PRESET CH +**", "**ZONE2 SOURCE**" and "**STATUS**" simultaneously, press the power button to turn on the power.

AVR-S720W

- While holding down buttons "**ZONE2 SOURCE**", "**TUNER PRESET CH +**" and "**TUNE +**" simultaneously, press the power button to turn on the power.

The device returns to the normal display message after the following is displayed.



Protection Pass

This is displayed for 5 seconds before returning to the normal display.

5. CY920 Reboot Mode

5.1. Actions

- The CY920 is restarted after CY920 hang up.
- The CY920 can be restarted even in the network standby setting. ("Setup menu" – "Network" – "IP Control" – "Always On")

5.2. Operations

- (1) Turn the "**MAIN ZONE**" button On and set the input source to NETWORK.
- (2) While the power is on, hold down buttons "**TUNER PRESET CH +**" and "**TUNER PRESET CH -**" for at least 3 seconds.

Display during CY920 reboot

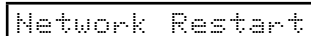

Network Restart

- (4) Returns to the normal display.

NOTE :

- After rebooting CY920, the same operation is not accepted for 1 minute.
- Reception is prohibited during update, save and load.

6. CY920 Initialization Mode

6.1. Actions

The following items are initialized.

- (1) Favorites
- (2) Quick Select
- (3) Presets
- (4) Internet Radio Recently Played
- (5) Flickr contacts
- (6) User ID
- (7) Resume Playback station

6.2. Operations

AVR-X1300W

- While the power is On, hold down buttons "**ZONE2 SOURCE**" and "**DIMMER**" for at least 3 seconds.

AVR-S720W

- While the power is On, hold down buttons "**TUNER PRESET CH +**" and "**TUNE -**" for at least 3 seconds.

Initializing Display

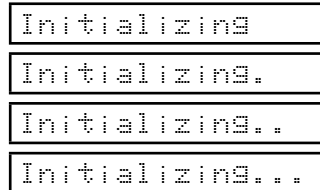

Initializing
Initializing.
Initializing..
Initializing...

Complete Display

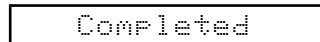

Completed

This is displayed for 5 seconds before returning to the normal display.

Failed Display

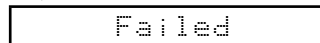

Failed

7. Clearing the Operation Info

7.1. Actions

- Displays the accumulated operating time of the unit, the number of times the power was switched on, and the number of occurrences of each protection.

7.2. Operations

Remove all input/output terminals and the AC plug.

Connect the AC plug again and place the product in standby mode.

AVR-X1300W

- While holding down buttons "**ZONE2 SOURCE**" and "**STATUS**" simultaneously, press the power button to turn on the power.

AVR-S720W

- While holding down buttons "**TUNER PRESET CH +**" and "**TUNE +**" simultaneously, press the power button to turn on the power.

PRODUCT MODE

When "**PRODUCT MODE**" appears on the display, release the button and press the "**Power**" button and "**ZONE2 ON/OFF**" to place the product in standby mode.

Service Path Check Mode

1.1. Actions

This function is convenient for confirming problem paths in the product and checking the paths after repairing.
The Video and Audio paths can be checked.
The backup data is not rewritten.

1.2. Starting up

AVR-X1300W

· While holding down buttons "ZONE2 SOURCE", "DIMMER" and "STATUS" simultaneously, press the power button to turn on the power.

AVR-S720W

· While holding down buttons "TUNER PRESET CH+", "TUNE -" and "TUNE +" simultaneously, press the power button to turn on the power.

Select the "1. SERVICE CHECK" using the "TUNER PRESET CH+" button, then press the "STATUS" button then to confirm.
The "TUNED", "STEREO" and "RDS" segments are lit in this mode.

1.3. Canceling diagnostic mode

Press the power button to turn off the power.

1.4. Selecting items to check

Press the ① button to switch between video items and audio items.
Press the ② or ③ button to select the previous or next item.

Actions	The unit			Remote control unit		
	①	②	③	①	②	③
	Audio ⇄ Video	PREVIOUS	NEXT	Audio ⇄ Video	PREVIOUS	NEXT
Button	DIMMER	QUICK SELECT 1	QUICK SELECT 2	SLEEP	CURSOR ◀	CURSOR ▶

1.5. Audio system confirmation items

See the block diagram fig.XXth.

Paths to be confirmed		Display	Settings	What to confirm
1	Analog	fig.01 A01:ANALOG PASS	Input Source : CBL/SAT Input Mode : Analog (fixed) Sound mode : DIRECT Amp assign : Surround Back MAIN ZONE : On ZONE2 : Off	• Analog input ⇒ Speaker output (Front L/R) (※ The input source can be switched to any source except CBL/SAT.)
2	DIGITAL (MAIN)	fig.02a fig.02b A02: DIGITAL	Input Source : CBL/SAT Input Mode : DIGITAL (fixed) Sound mode : MULTI CH STEREO Amp assign : Surround Back Speaker Config ALL Speaker = Small / SW = Yes(2ch) MAIN ZONE : On ZONE2 : Off	• Digital input ⇒ Speaker output (Front L/R, Center, Surround L/R, Surround Back L/R) • Digital input ⇒ Pre OUT output (Subwoofer) (※ The input source can be switched to any source except CBL/SAT.)
3	DIGITAL (ZONE2)	fig.03a fig.03b A03: DIGITAL-Z2	Input Source : NETWORK Input Mode : Auto Sound mode : STEREO Amp assign : ZONE2 MAIN ZONE : On ZONE2 : On	• Digital(PCM) input ⇒ Speaker output (ZONE2 L/R) • Digital(PCM) 入力 ⇒ Pre OUT output (ZONE2 L/R) (X1300E3 only)

Paths to be confirmed			Display	Settings	What to confirm
4	HDMI	fig.04a fig.04b	A05:HDMI	Input Source : CBL/SAT Input Mode : HDMI (fixed) Sound mode : STEREO Amp assign : Surround Back MAIN ZONE : On ZONE2 : Off	<ul style="list-style-type: none"> • HDMI input ⇒ Speaker output (Front L/R) (※ The input source can be switched to any source except CBL/SAT.)
5	Analog AD (MAIN)	fig.05a fig.05b	A06:AD	Input Source : CBL/SAT Input Mode : Analog (fixed) Sound mode : MULTI CH STEREO Vol 60.0 Amp assign : Surround Back Speaker Config ALL Speaker = Small / SW = Yes(2ch) MAIN ZONE : On ZONE2 : Off	<ul style="list-style-type: none"> • Analog input ⇒ Speaker output (Front L/R, Center, Surround L/R, Surround Back L/R) • Analog input ⇒ Pre OUT output (Subwoofer) (※ The input source can be switched to any source except CBL/SAT.) (※ Volume 60 is the value when Absolute settings are used. The value is -20dB when Relative settings are used)
6	Analog Amp Assign (Amp Assign : ZONE2)	fig.06	A07:ASSIGN-Z2	Input Source : CBL/SAT Input Mode : Auto Sound mode : STEREO Z2 Source : Source Vol 60.0 Amp assign : ZONE2 MAIN ZONE : On ZONE2 : On	<ul style="list-style-type: none"> • Analog input ⇒ Speaker output (ZONE2 L/R) • Analog input ⇒ Pre OUT output (ZONE2 L/R) (※ The input source can be switched to any source except CBL/SAT.) (※ Volume 60 is the value when Absolute settings are used. The value is -20dB when Relative settings are used)

1.6. Confirmation items for the video system

See the block diagram fig.XXth.

Paths to be confirmed			Display	Settings	What to confirm
1	Analog Video pass	fig.07	V01:VIDEO PASS	Input Source : CBL/SAT MAIN ZONE : On	<ul style="list-style-type: none"> • CVBS input ⇒ CVBS output (※ The input source can be switched to any source except CBL/SAT.)
2	HDMI pass	fig.08	V03:HDMI PASS	Input Source : CBL/SAT MAIN ZONE : On	<ul style="list-style-type: none"> • HDMI input (MAIN function) ⇒ HDMI output (MAIN) (※ The input source can be switched to any source except CBL/SAT.)
3	HDMI CEC	fig.09	V04:HDMI CEC	Input Source : CBL/SAT HDMI Control : On MAIN ZONE : On	<ul style="list-style-type: none"> • When the power supply of a TV is put in the standby mode, make sure that the power supply of this unit is also put in the standby mode. (※ The input source can be switched to any source except CBL/SAT.) • The ARC path can also be checked (check this using the TV input source).
4	HDMI Audio (Audio : AVR)	fig.04a fig.04b	V05:H.AUDIO-AVR	Input Source : CBL/SAT HDMI Control : Off HDMI Audio : AVR (if checking the audio output from AVR)	<ul style="list-style-type: none"> • HDMI input (PCM , DolbyDigital , DTS) ⇒ Speaker output. • HDMI input(HD audio) ⇒ Speaker output. (※ The input source can be switched to any source except CBL/SAT.)
5	HDMI Audio (Audio : TV)	fig.10	V06:H.AUDIO-TV	HDMI Audio : TV (if checking the audio from TV)	<ul style="list-style-type: none"> • HDMI input (PCM, DolbyDigital , DTS) ⇒ HDMI output (audio output from connected TV) (※ The input source can be switched to any source except CBL/SAT.)
6	GUI	fig.11	V07:GUI MENU ON	Input Source : CBL/SAT Setup Menu : On MAIN ZONE : On	<ul style="list-style-type: none"> • GUI display ⇒ HDMI output. (※ The input source can be switched to any source except CBL/SAT.)

AVRS720W/X1300W ANALOG AUDIO BLOCK

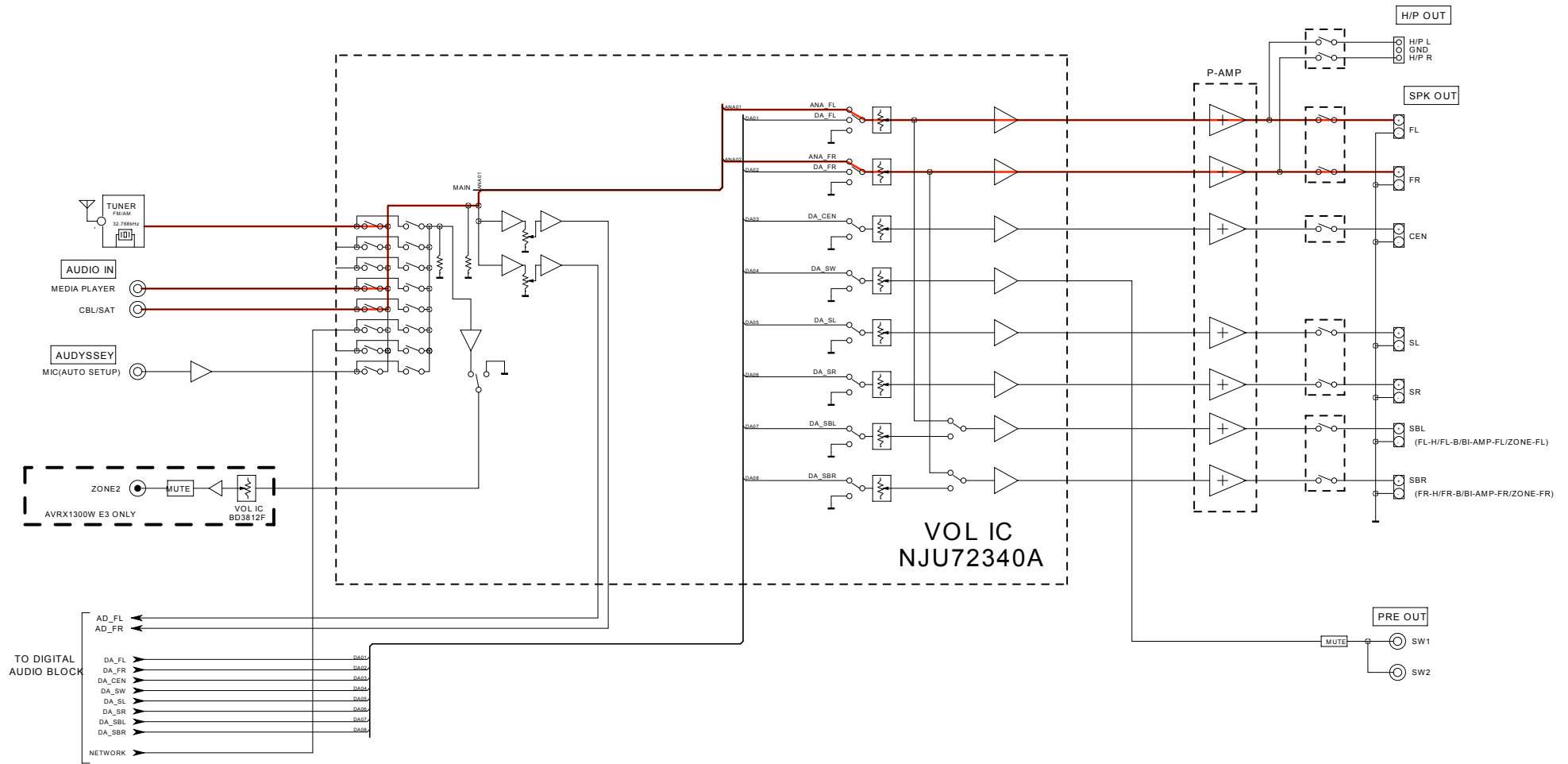

fig.02a

AVRS720W/X1300W DIGITAL AUDIO BLOCK

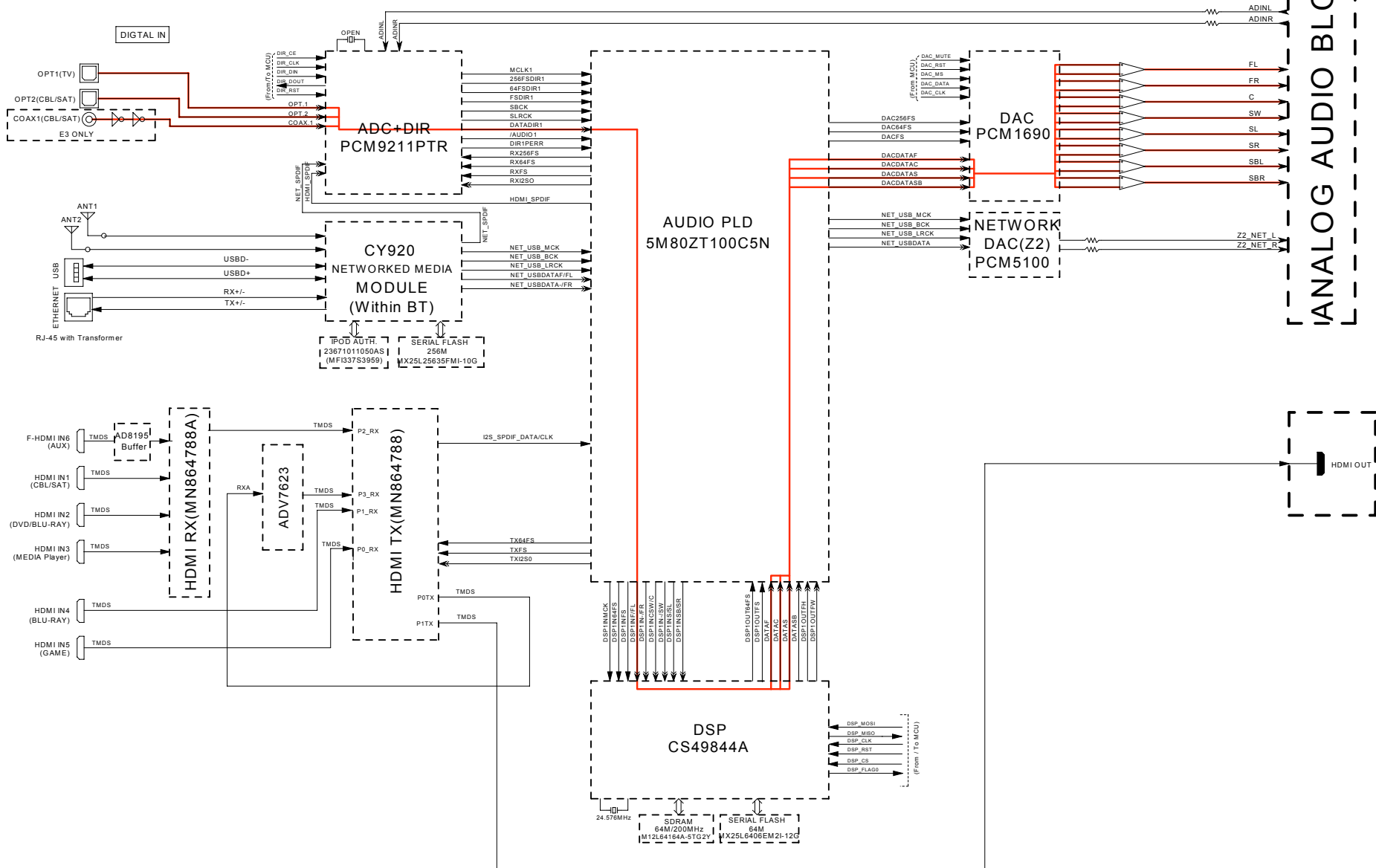

fig.02b

AVRS720W/X1300W ANALOG AUDIO BLOCK

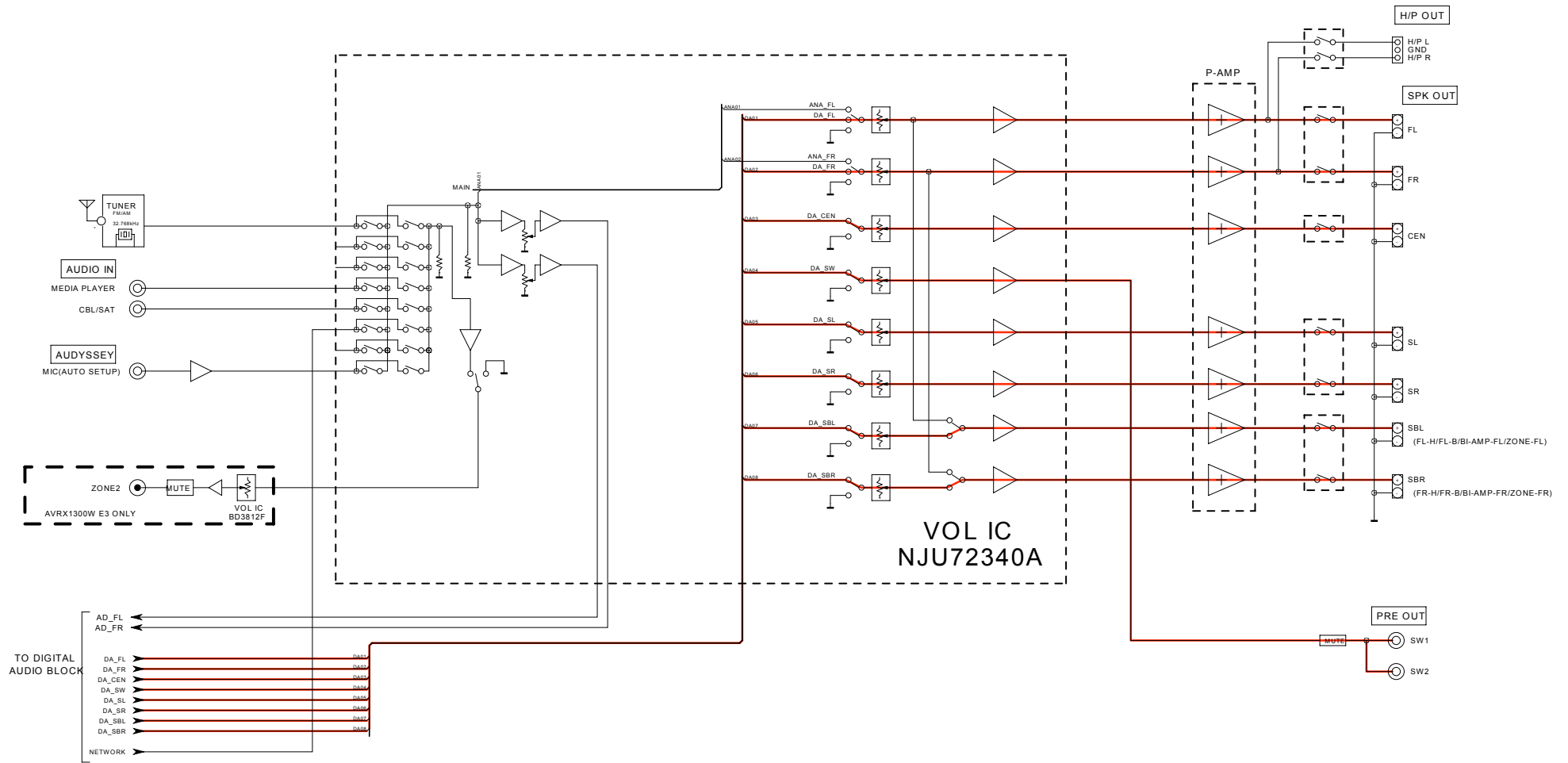

fig.03a

AVRS720W/X1300W DIGITAL AUDIO BLOCK

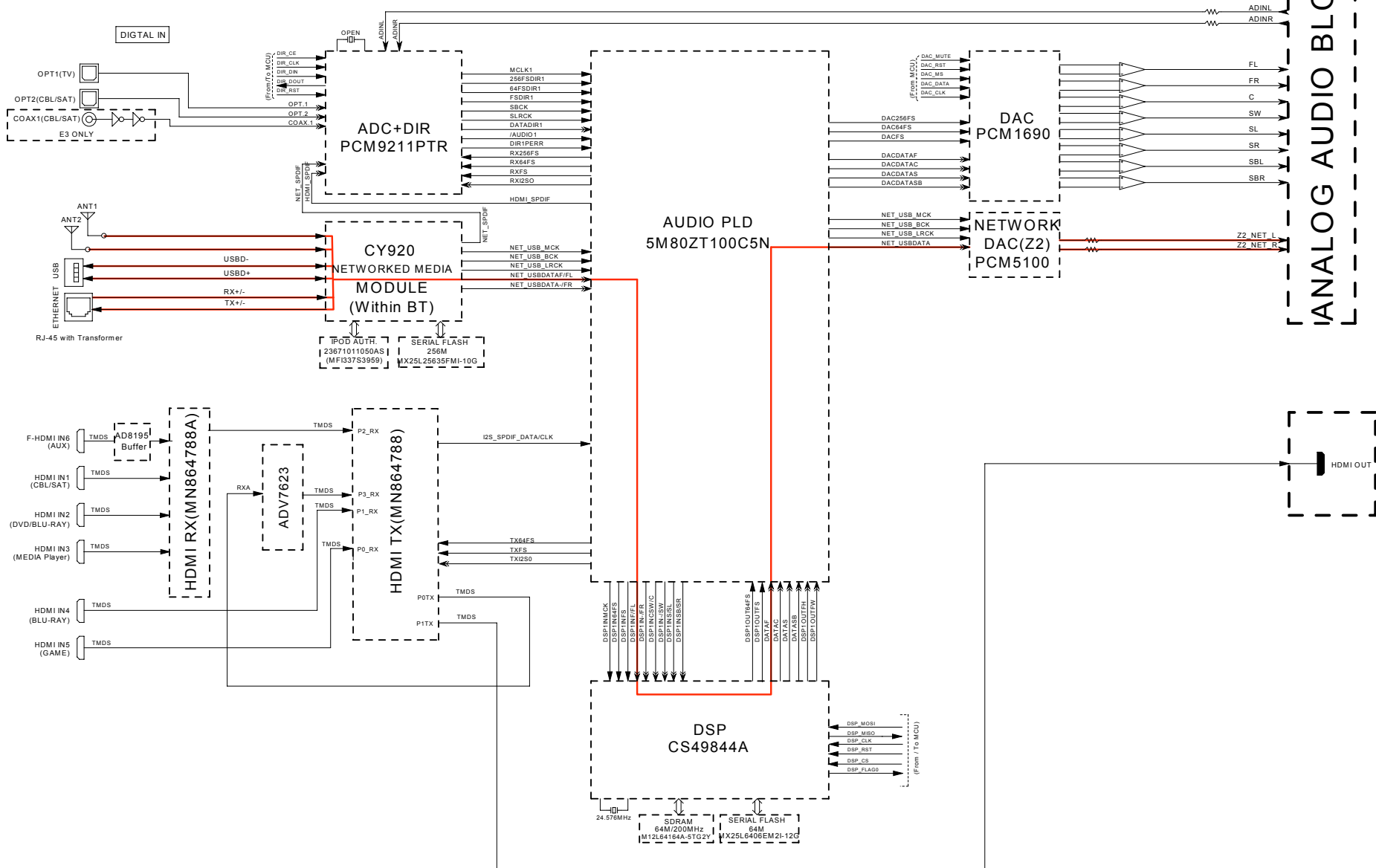

fig.03b

AVRS720W/X1300W ANALOG AUDIO BLOCK

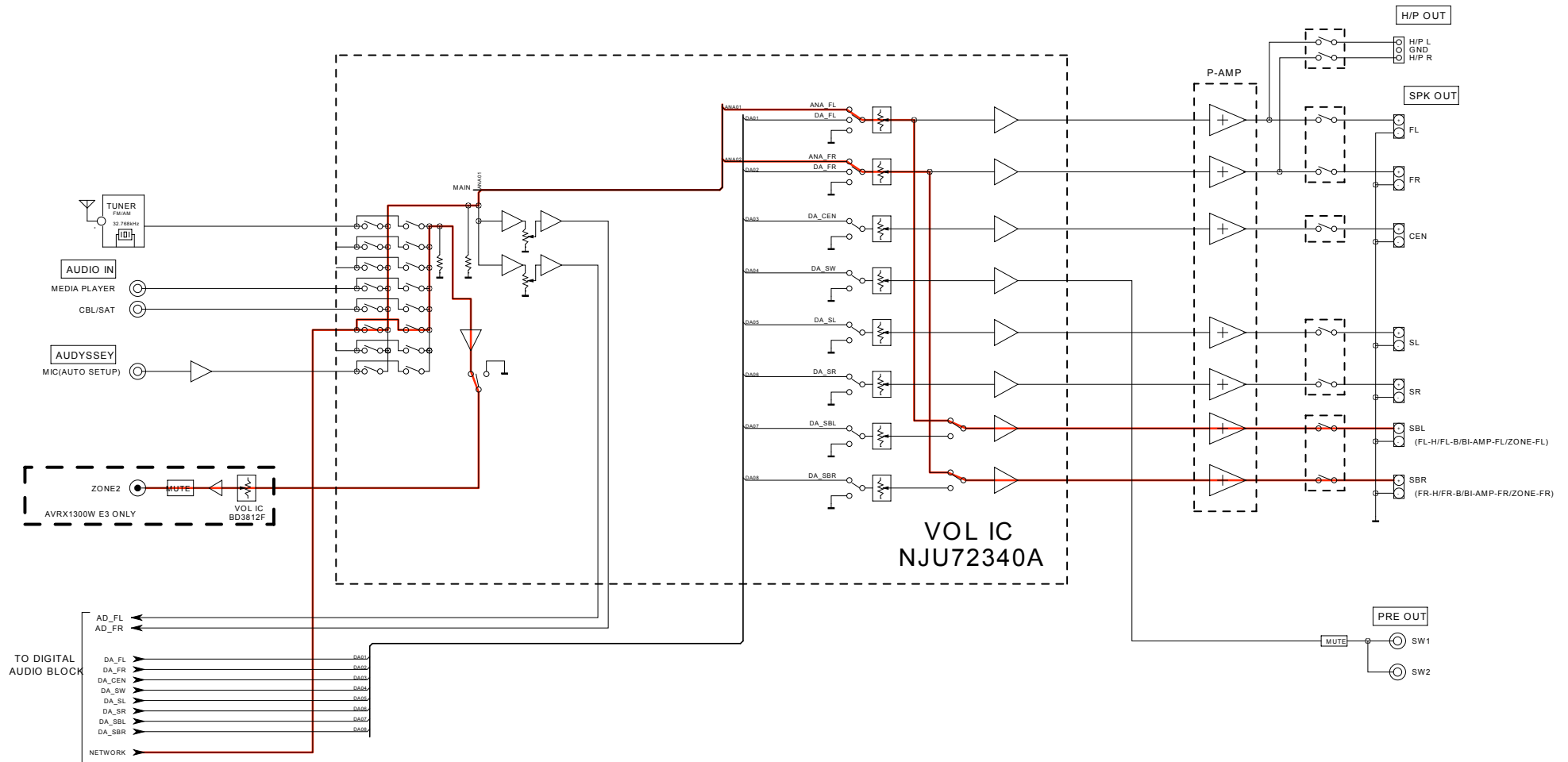

fig.04a

AVRS720W/X1300W DIGITAL AUDIO BLOCK

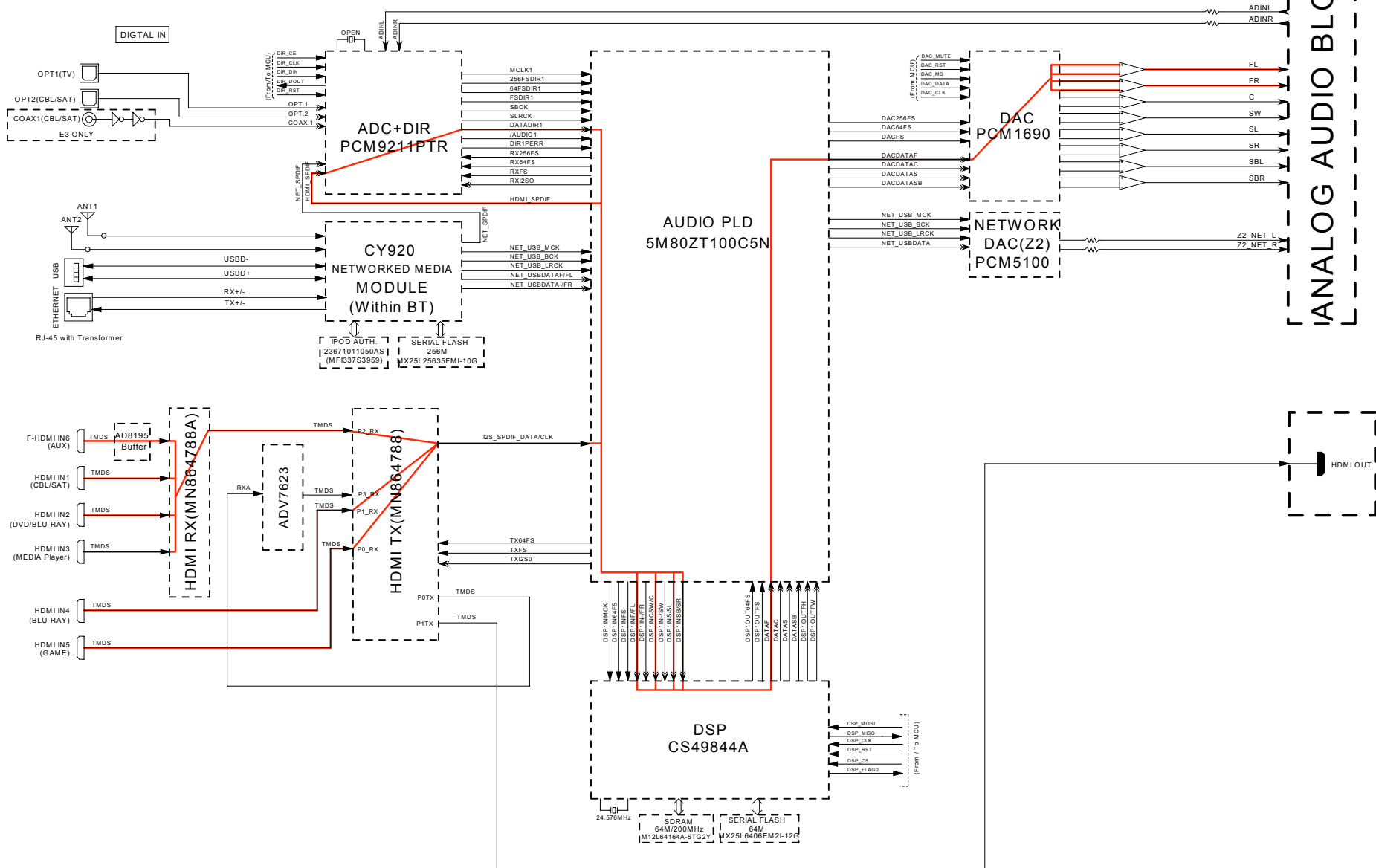

fig.04b

AVRS720W/X1300W ANALOG AUDIO BLOCK

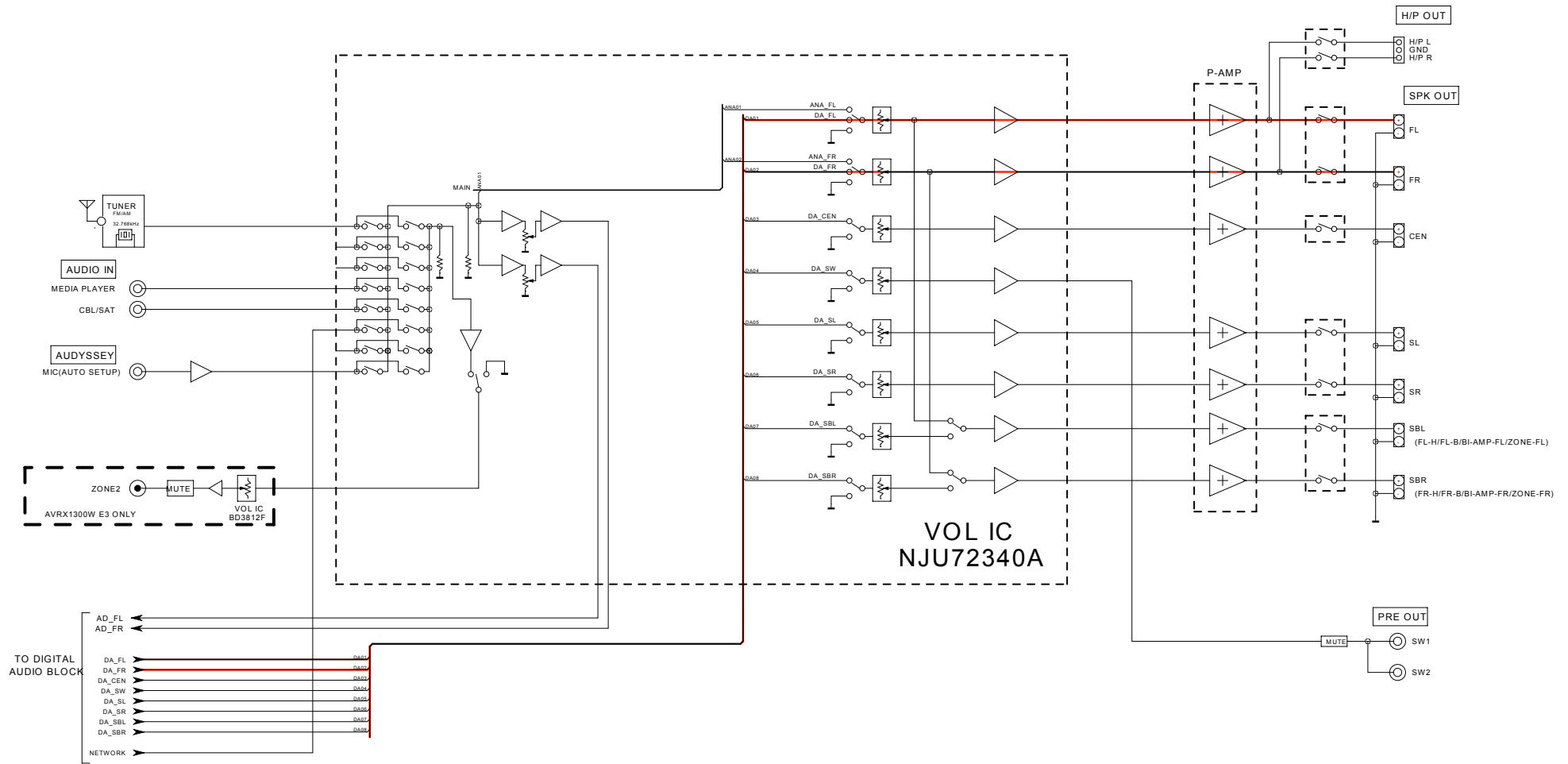

fig.05a

AVRS720W/X1300W DIGITAL AUDIO BLOCK

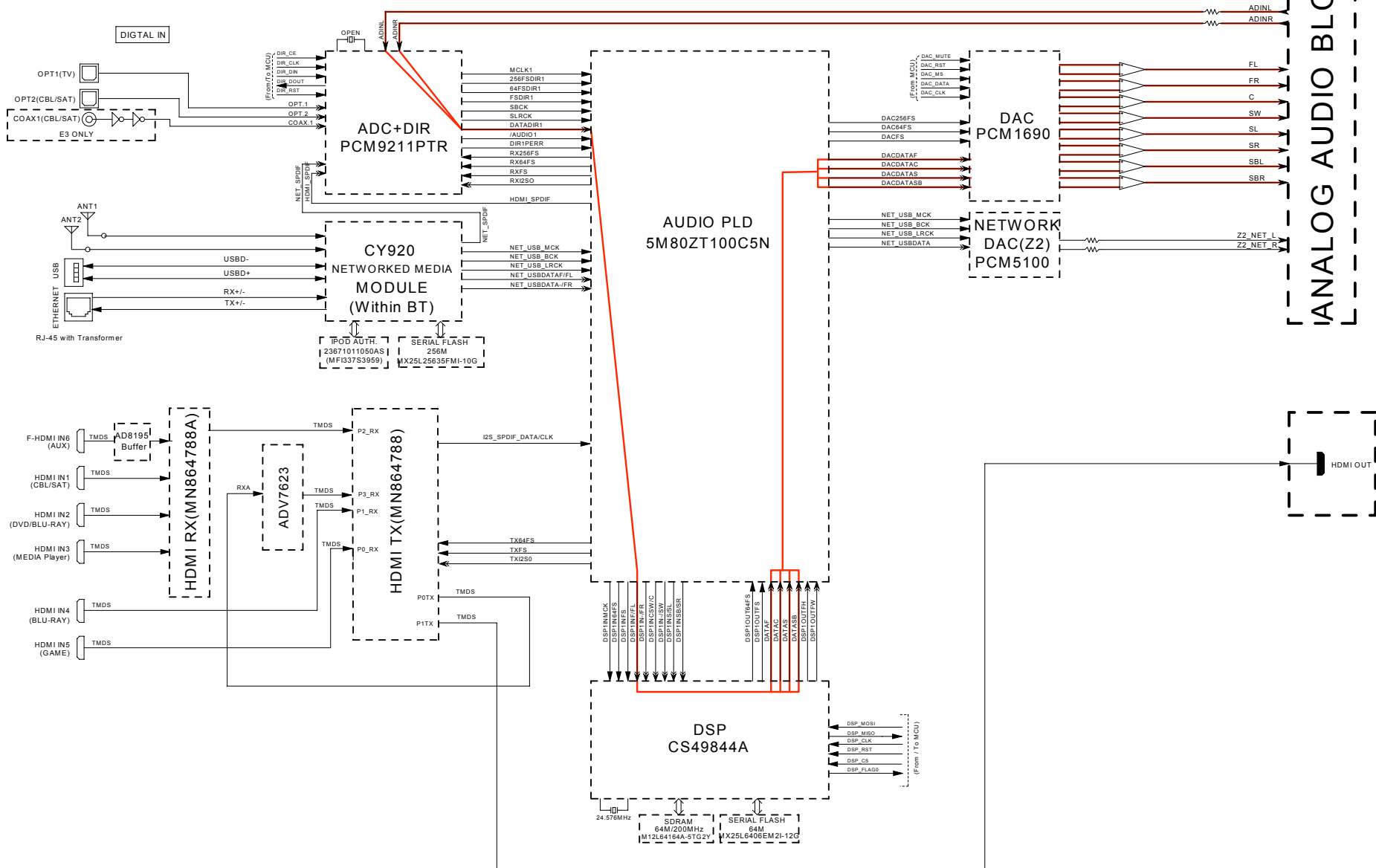

fig.05b

AVRS720W/X1300W ANALOG AUDIO BLOCK

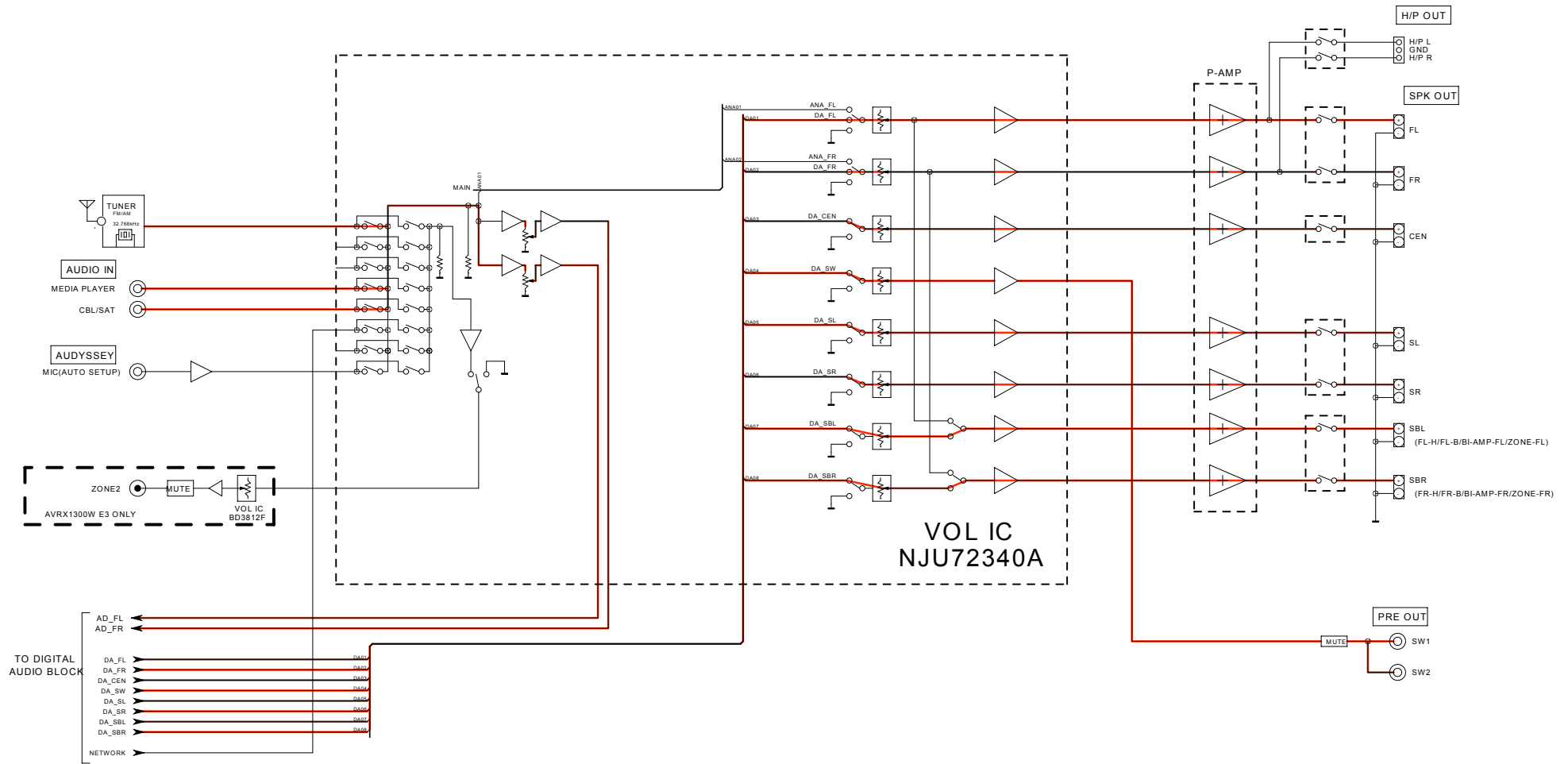

fig.06

AVRS720W/X1300W ANALOG AUDIO BLOCK

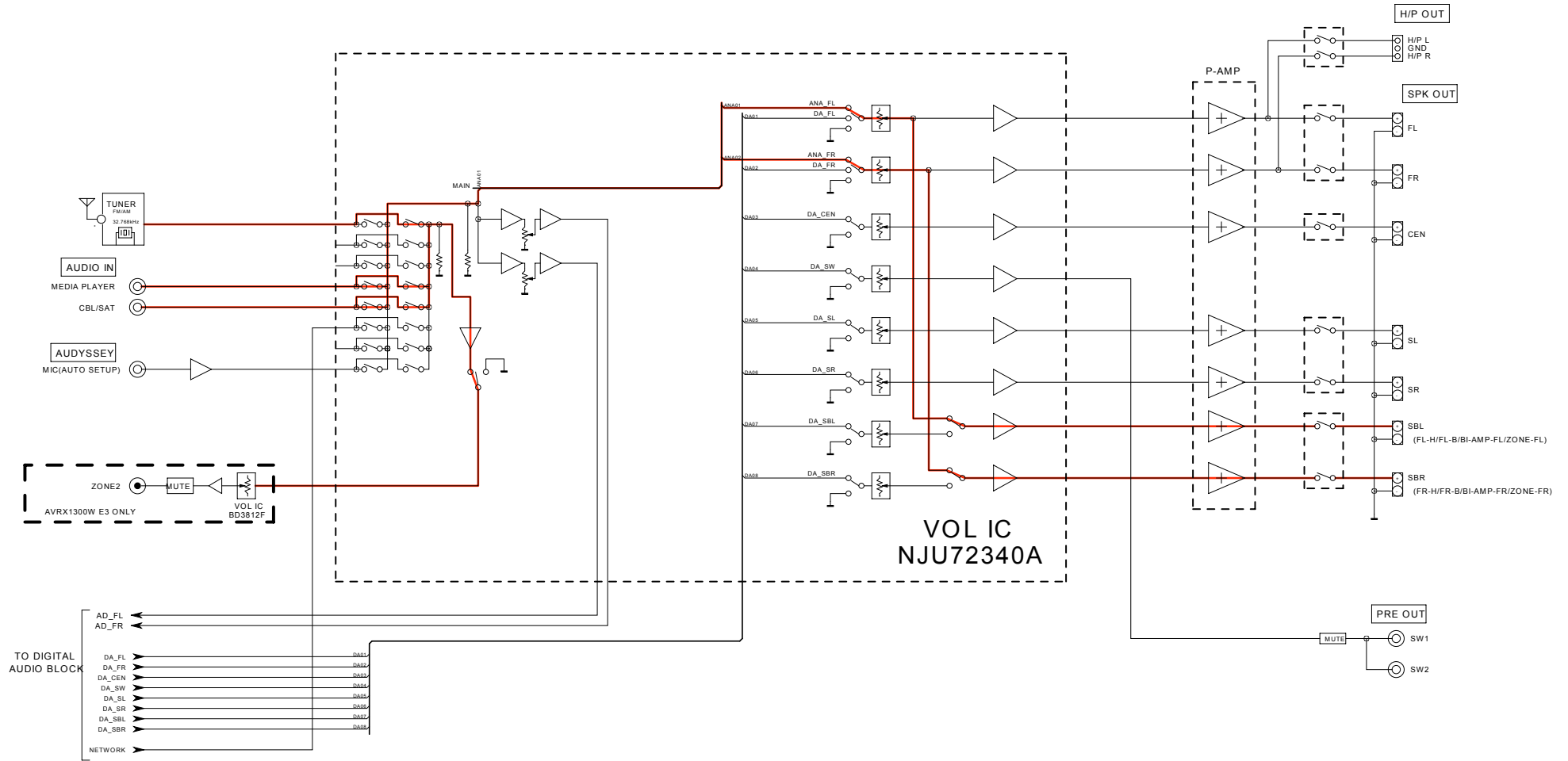

fig.07

AVRS720W/X1300W VIDEO BLOCK

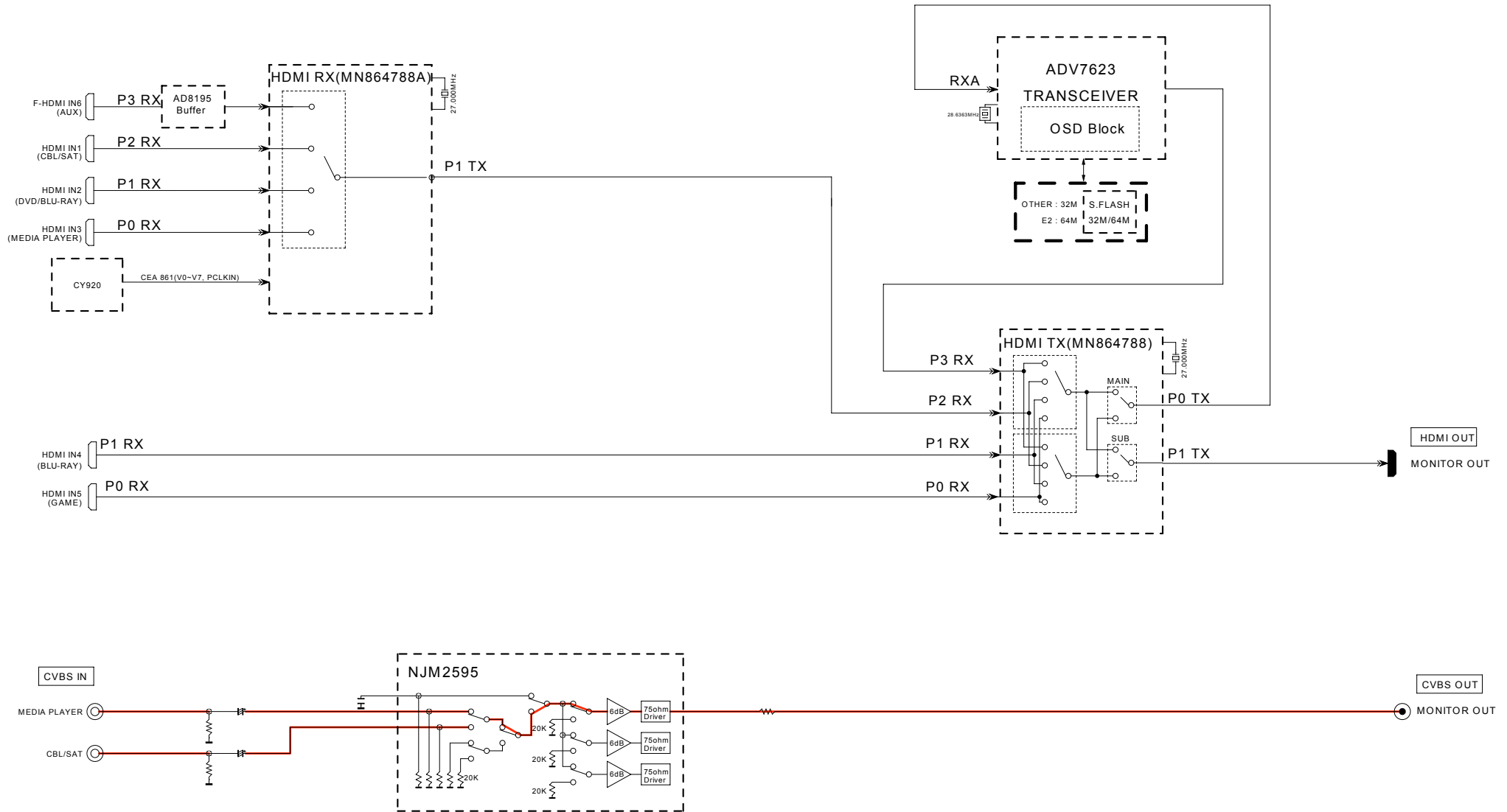

fig.08

AVRS720W/X1300W VIDEO BLOCK

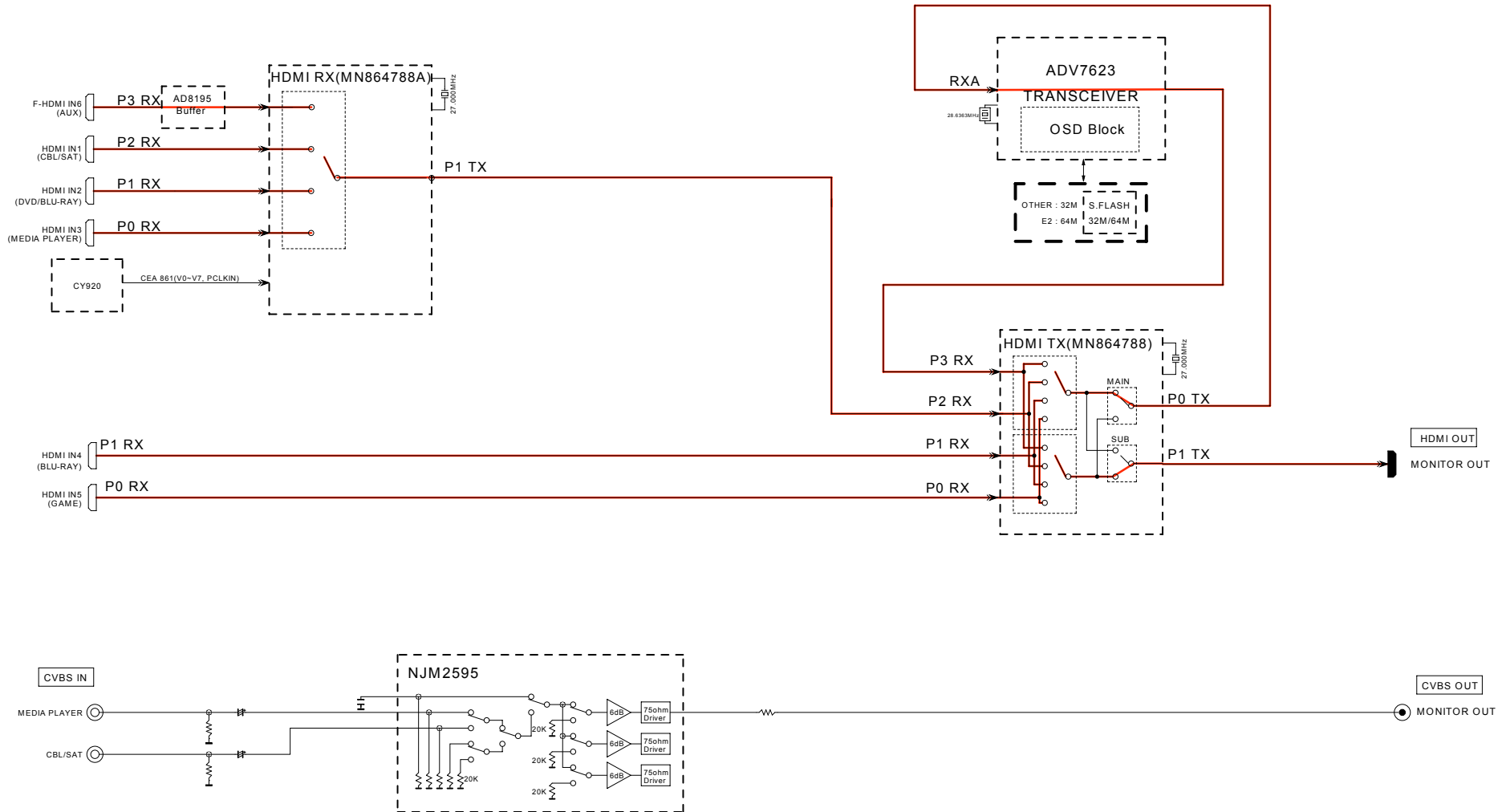

fig.09

AVRS720W/X1300W VIDEO BLOCK

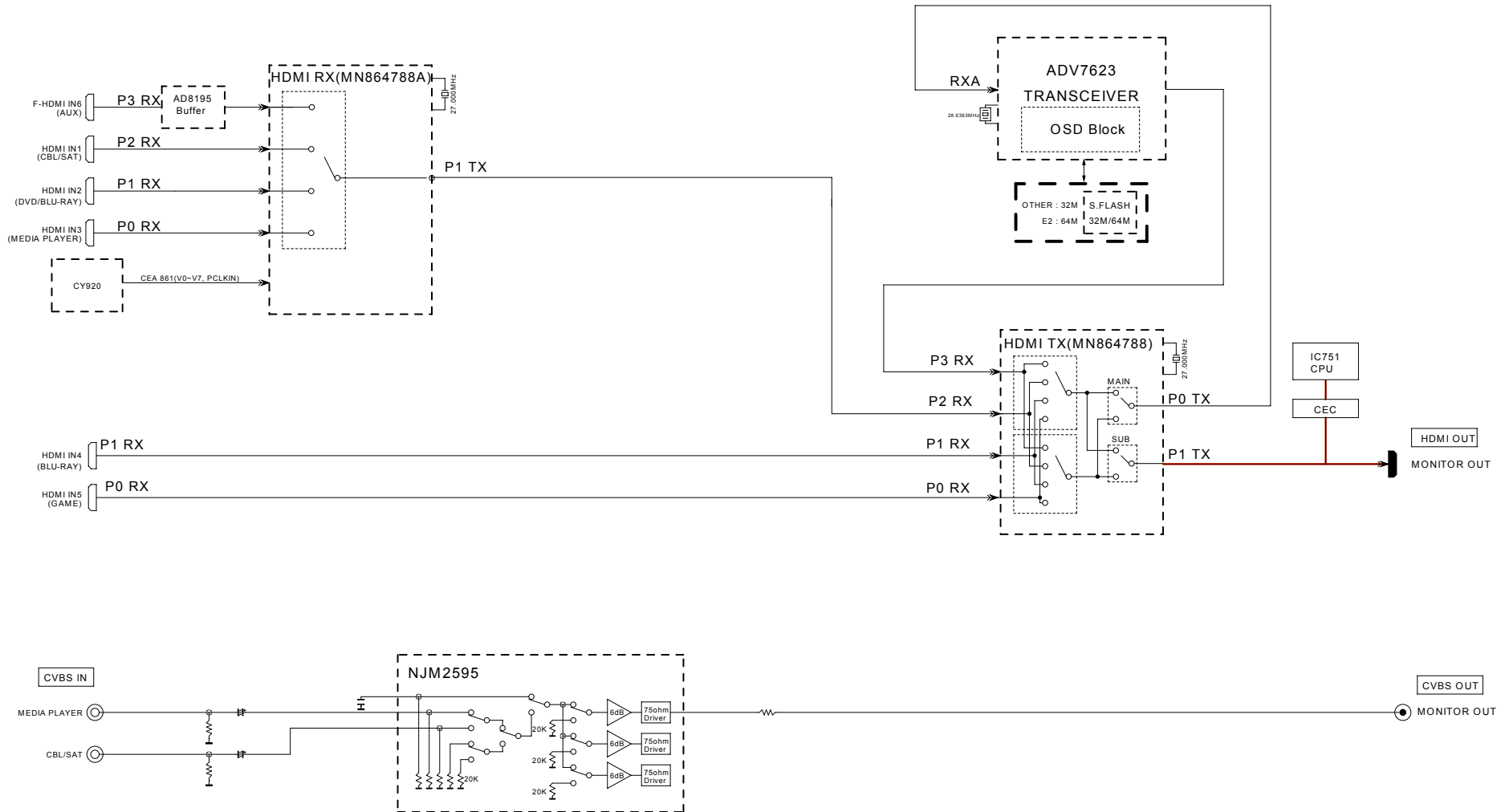

fig.10

AVRS720W/X1300W DIGITAL AUDIO BLOCK

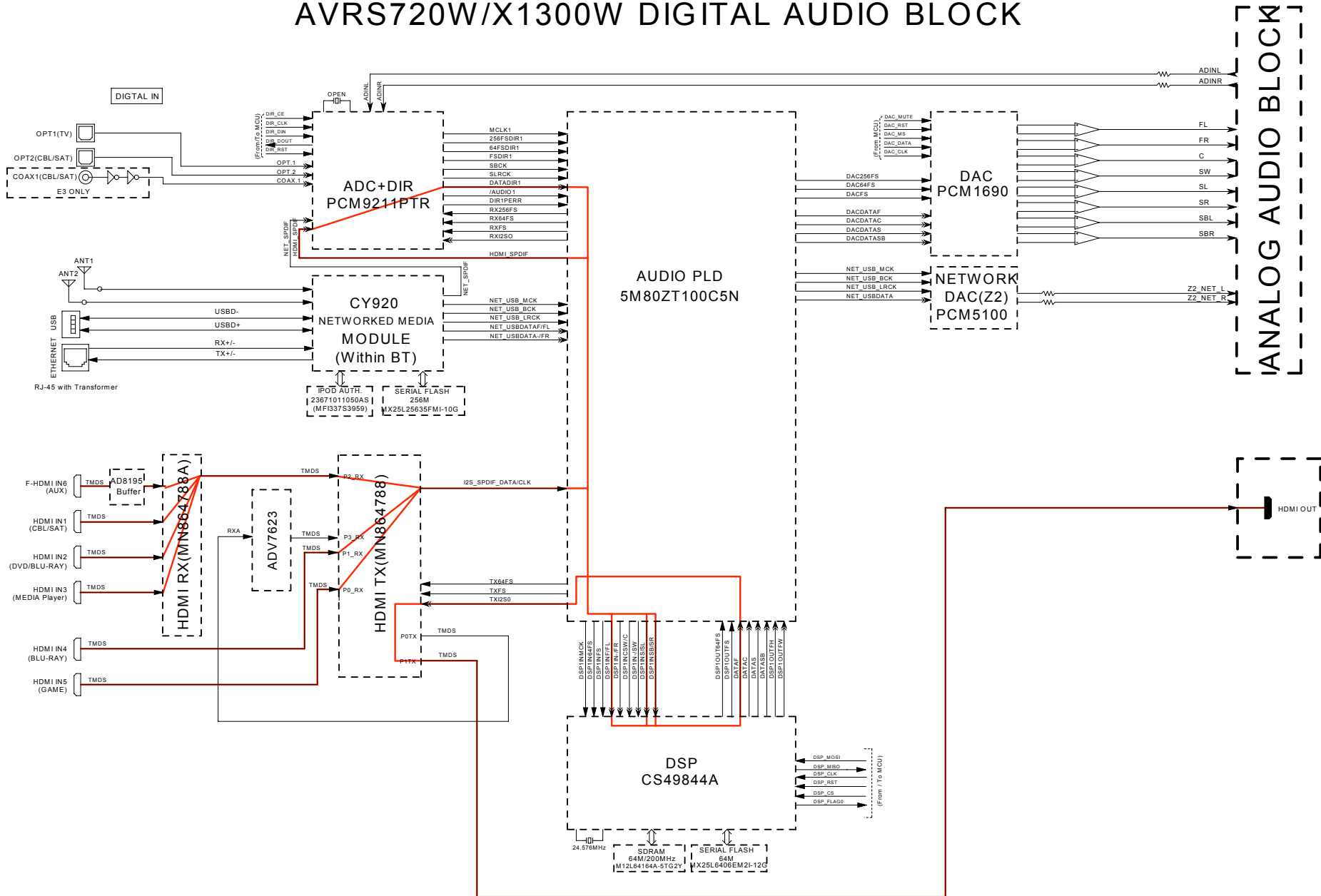
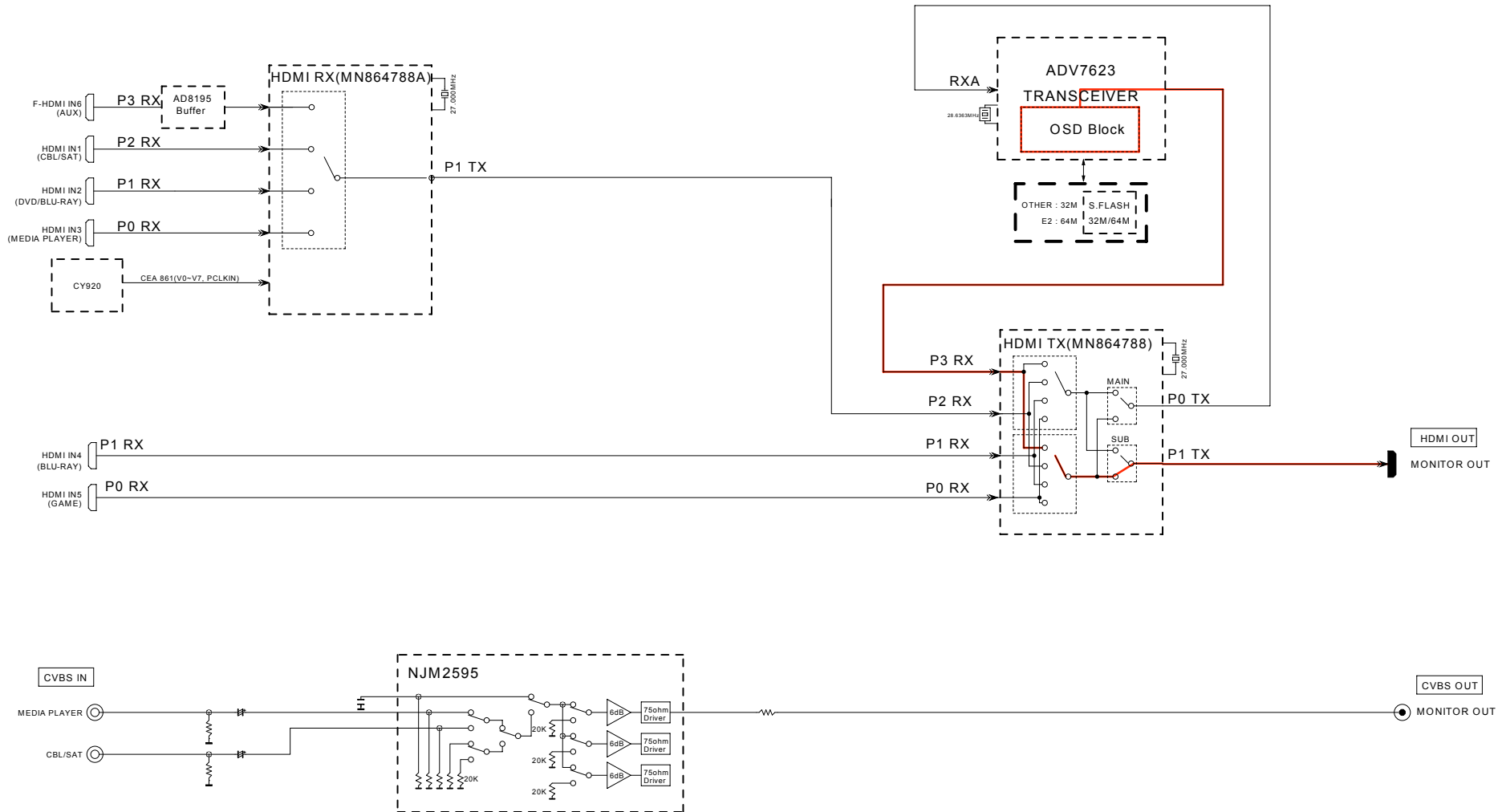

fig.11

AVRS720W/X1300W VIDEO BLOCK



Use the following jigs (extension cable kit) when repairing the PCBs.
Order with your dealer for the jigs your dealer if necessary.

CAUTION : Incorrect connections may cause malfunction.

Connection of Jig for DIGITAL PCB

---Items to Be Prepared---

8U-110084S : EXTENSION UNIT KIT : 1Set
Insulation sheet (Not supplied) : 1 sheet
Ground lead (Not supplied) : 2 pc

-Proceeding-

(1) Remove the screws.



(2) Remove the connector PCB.

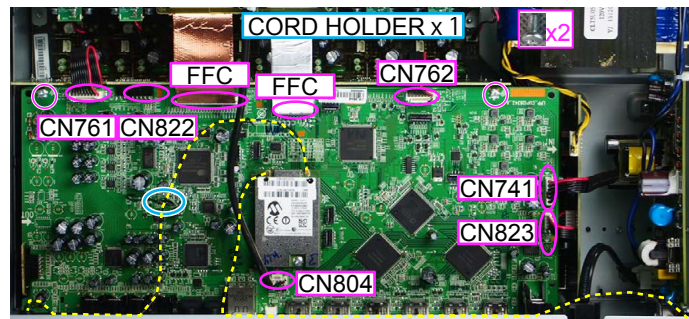

(3) Remove the DIGITAL PCB from the chassis and turn it over.

Place an insulation sheet larger than the PCB underneath the DIGITAL PCB.

※ Connect the earth of the PCB to the chassis using an earth wire, etc.

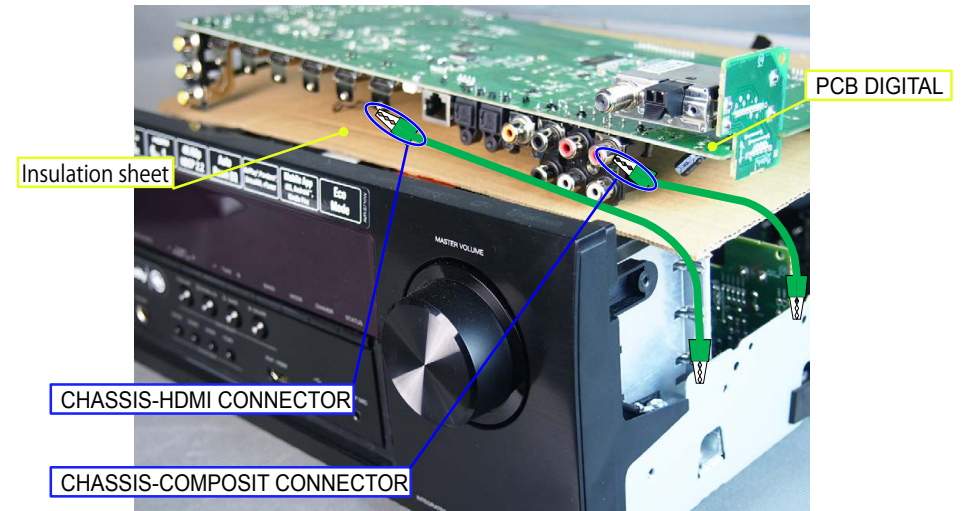

(4) Connect the expansion cables.



Board-to-Board Connections

No.	Pin	Ref. No.	PCB		Ref. No.	PCB
①	15pin	CN201	DIFF-AMP	↔	CN822	DIGITAL

UPDATING

PROCEDURE AFTER REPLACING THE PCB.

PROCEDURE AFTER REPLACING THE U-COM, ETC.

FIRMWARE UPDATE PROCEDURE

1. Items necessary for update
2. Updating via USB
3. Updating via DPMS

PROCEDURE AFTER REPLACING THE PCB.

The procedure after replacing the printed circuit boards is as follows.

(1) Change the resistor for setting the region.

Model Area	DIGITAL PCB	
	R7581	R7582
North America (E3)	OPEN	0
Europe (E2)	0	OPEN
China (E1C)	10k	10k
Japan (JP)	10k	22k
AVR-S720W	18K	3.3K

See the PCB below.

(2) Be sure to replace the software with the latest version.

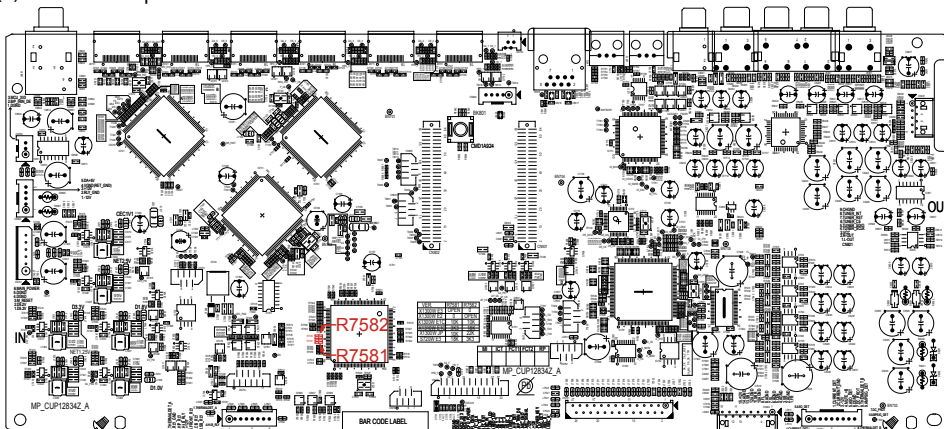

PROCEDURE AFTER REPLACING THE U-COM, ETC.

The procedure after replacing the u-COM (microprocessor), flash ROM, etc. is as follows.

PCB Name	Ref. No.	Description	Procedure after Replacement	Remark
DIGITAL	IC751	R5F56108VNFP	B	SOFTWARE : Main
DIGITAL	IC782	MX25L6406EM2I-12G	B	SOFTWARE : DSP ROM
DIGITAL	IC732	MX25L3206EM2I-12G MX25L6406EM2I-12G (E2 only)	B	SOFTWARE : GUI ROM
DIGITAL	IC773	5M80ZT100C5N	B	SOFTWARE : AUDIO PLD
MODULE	P14	CY920 MODULE	D	SOFTWARE : SBL.bcd / IMG.bcd ※1
DIGITAL	IC803	MX25L25635FMI-10G	C	SOFTWARE : IMG.bcd ※1

※1 The firmware for the CY920 MODULE is written to the INTERNAL ROM of the CY920 and the IC803 (EXTERNAL ROM) of the DIGITAL circuit board.

"**CY920 Error**" appears in the display if the DIGITAL PCB or the CY920 is replaced, as this results in the version of the INTERNAL ROM differing from that of the EXTERNAL ROM.

In this case, see "[2.10. Update Procedure in the Event of a CY920 Error](#)".

(This does not require special operations such as pushing multiple buttons at the same time. The firmware also cannot be updated via DPMS.)

Procedure after Replacement

A : The software has been written. The software is not written at the time of replacement.

B : The software has been written. The software may need to be rewritten by version updates. Check the version.

C : The software has not been written. The software needs to be written after replacement.

See "[FIRMWARE UPDATE PROCEDURE](#)" for information on writing the software.

D : The software has been written. Be sure to rewrite with the latest software for your service region.

See "[FIRMWARE UPDATE PROCEDURE](#)" for information on writing the software.

FIRMWARE UPDATE PROCEDURE

1. Items necessary for update

Items necessary for update are as follows.

Update Type	Needed Part for Update	Requirement	Offered / not Offered		
			Standard Service Equipment Not offered by D&M	Purchase from D&M Article code	Download from SDI
Via USB	USB Stick (USB 2.0 : Min 1GB)	Formatting FAT 32	X	-	2.3. File structure on USB Memory
Via DPMS	Internet Connection by Broadband Circuit		X	-	
	Modem		X	-	
	Router		X	-	
	Ethernet cable (CAT-5 or greater is recommended)		X	-	

Caution in
servicing

Electrical

Mechanical

Repair Information

Updating

2. Updating via USB

The latest firmware can be downloaded to a USB memory for updates.

2.1. Connecting to the USB Memory

(1) Preparation

- Use a memory that supports USB2.0.
- USB format : Prepare a USB memory formatted in FAT16 or FAT32.
- Do not run the USB memory through a hub.
- Do not connect a computer to the USB port of this unit using a USB cable.
- Do not use an extension cable when connecting the USB unit.
- If a USB memory device cannot be updated, replace it with a different USB memory device and perform the update again.

2.2. Unzipping the Downloaded File

Unzip the downloaded file on your computer.

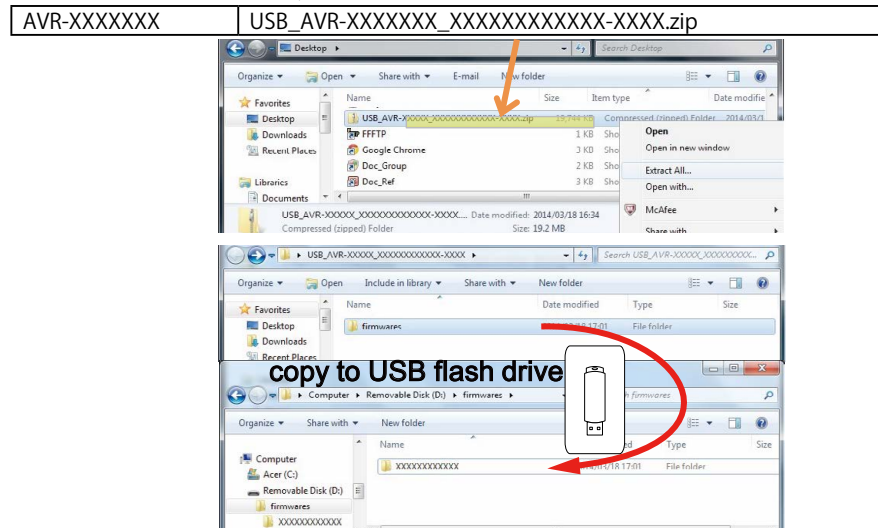

The "**firmware**" folder is created upon unzipping the file.

Copy that folder to USB flash drive.

The "**firmware**" folder must be in the root directly of the USB flash drive (memory).

2.3. File structure on USB Memory

Copy the update files to the USB memory with the following structure.

USB memory root

Model Name	Model Area	Product ID
AVR-X1300WE3	North America (E3)	000100900100
AVR-X1300WE2	Europe (E2)	000100900200
AVR-X1300WJP	Japan (JP)	000100900400
AVR-X1300WE1C	China (E1C)	000100900500
AVR-S720W	North America (E3)	000100900700

- + firmwares
- + 000100XXXXXX
- + APLD.bin
- + DSP.bin
- + enc_update.xml
- + GUI.bin
- + IMG.bcd
- + MAIN.bin
- + SBL.bcd

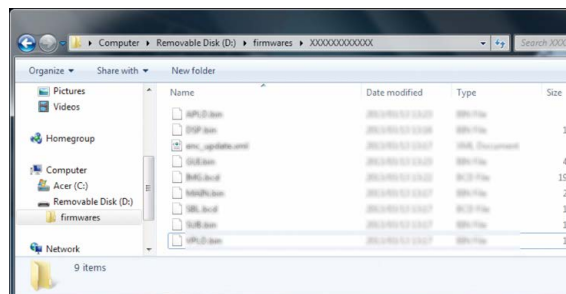

2.4. Insert the USB memory into the USB port.

NOTE : Remove the LAN cable from this unit when performing updates.

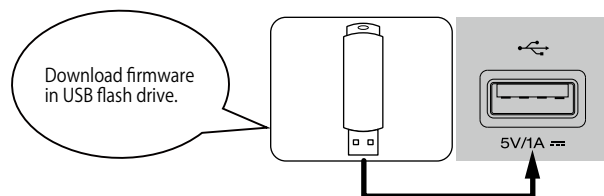

2.5. Start the update.

AVR-X1300W

- While holding down buttons "TUNER PRESET CH +" and "STATUS" simultaneously, press the power button to turn on the power.

AVR-S720W

- While holding down buttons "ZONE2 SOURCE" and "TUNE +" simultaneously, press the power button to turn on the power.

2.6. Display during USB update

After around half minutes, display shows the following message.

USB Update Start

2.7. Press the "ENTER" key on the remote control unit or this unit.

Then start Firmware Update.

UpdateFileCheck

2.8. The firmware update finishes.

When the update is completed, the following message appears on the display, then the unit returns to the normal status.

UpdatingComplete

---Cautions on Firmware Update---

- Never remove the USB memory before the update is finished.
- Do not turn off the power until updating is completed.
- It takes around 1 hour to complete the update.

Once an update is started, normal operations cannot be performed until it is completed. The GUI menu settings and image adjustment settings of this unit may be initialized. Note down the settings before updating, and set them again after updating.

2.9. Forced USB All Device Write Mode

2.9.1. Actions

Mode used when this unit cannot be recovered.
Forcibly switches this unit to USB update mode.

2.9.2. Operations

AVR-X1300W

- While holding down buttons the "TUNER PRESET CH +" and "STATUS" buttons simultaneously, insert the AC plug to turn the power on.

AVR-S720W

- While holding down buttons the "ZONE2 SOURCE" and "TUNE +" buttons simultaneously, insert the AC plug to turn the power on.

```
USB AllUpdate
USB AllUpdate.
USB AllUpdate..
USB AllUpdate...
```

2.9.3. The firmware update finishes.

Returns to the normal status after update is completed.

2.10. Update Procedure in the Event of a CY920 Error

2.10.1. Actions

Perform the following update procedure if "CY920 Error" appears in the display when the power is turned on after replacing the DIGITAL PCB or the CY920.

2.10.2. Operations

- Remove the AC power plug and turn off the power.
- Copy the update file to a USB memory device and insert the USB memory device in the USB port.
- Insert the AC plug and turn on the power.
- The update starts automatically after "CY920 Error" appears in the display.

```
UpdateFileCheck
```

- The firmware update finishes.

```
Update Complete
```

The unit restarts after the update is finished.

- After the update, check that "CY920 Error" is no longer displayed, and check the version of the new firmware.
See "[1. Version Display Mode](#)"

2.11. About the error codes

See the table below for error codes and details of faults when the firmware is updated through USB memory.

The error code is displayed as four digits made up of the Device ID below together with **YY (** : Device ID, YY : Error Code).

Device ID	Device Name
00	n/a(※ 1)
01	Main CPU
11	DSP
12	DSP2(※ 2)
13	DSP3(※ 2)
19	DSP4(※ 2)
15	Audio PLD
22	Video PLD
2A	GUI Serial Flash
02	CY920 2nd BootLoader
03	CY920 Image

※ 1 Used when there are no device related errors

※ 2 For SR6011

Error Code	USB Update Error Display	Details of Error code	Remedies
01	Update Error**01	Unable to detect USB.	Reinsert or Try a new USB device and try again.
02	Update Error**02	No Firmware File in USB.	Check the file and try again.
03	Update Error**03	The Firmware File in the USB does not support your model and area.	Make sure the model name and area of the Firmware File and try again.
04	Update Error**04	Failed to obtain the Firmware information (Device Information)	Try a new USB device and try again.
05	Update Error**05	Time Out while obtaining the Firmware information (Device Information)	Start the USB Update again.
06	Update Error**06	Failed to obtain the Firmware information (Package Version)	Try a new USB device and try again.
07	Update Error**07	Time Out while obtaining the Firmware information (Package Version)	Start the USB Update again.
08	Update Error**08	Error notification received while requesting the Firmware Info.	Try a new USB device, Unplug and reconnect the AC plug, and try again.

Error Code	USB Update Error Display	Details of Error code	Remedies
09	Update Error**09	Time Out while obtaining Firmware information.	Unplug and reconnect the AC plug, and try again.
0A	Update Error**0A	Unable to detect USB for Firmware Download.	Reinsert or try a new USB device, Unplug and reconnect the AC plug, and try again.
0B	Update Error**0B	No Firmware File for Firmware Download.	Check the file, Unplug and reconnect the AC plug, and try again.
0C	Update Error**0C	Received value with the invalid Package Version.	Unplug and reconnect the AC plug, and try again.
10	Update Error**10	No Update Packet received from CY920 (Time Out).	Unplug and reconnect the AC plug, and try again.
11	Update Error**11	Abnormal data in Update Packet received from CY920 (CRC Error).	Unplug and reconnect the AC plug, and try again.
12	Update Error**12	Abnormal data in Update Packet received from CY920 (Packet No Error).	Unplug and reconnect the AC plug, and try again.
13	Update Error**13	Failed in Block Erase before rewriting Main.	Unplug and reconnect the AC plug, and try again.
14	Update Error**14	Failed in Block Write while rewriting Main	Unplug and reconnect the AC plug, and try again.
15	Update Error**15	Error in Verify after rewriting Main (Check Sum Error).	Unplug and reconnect the AC plug, and try again.
16	Update Error**16	Setup failure of the XModem transfer method.	Unplug and reconnect the AC plug, and try again. If the same error occurs even when it is retried, the device may be malfunctioning.
20	Update Error**20	Unable to detect USB after SBL Mode.	Reinsert or try a new USB device, Unplug and reconnect the AC plug, and try again.
21	Update Error**21	No Firmware File in USB after SBL Mode.	Check the file, Unplug and reconnect the AC plug, and try again.
22	Update Error**22	After SBL Mode, the Firmware File in the USB does not support your model and area.	Make sure the model name and area of the Firmware File, Unplug and reconnect the AC plug, and try again.

Error Code	USB Update Error Display	Details of Error code	Remedies
23	Update Error**23	Failed to obtain the entire Firmware information after SBL Mode.	Try a new USB device, Unplug and reconnect the AC plug, and try again.
24	Update Error**24	Time Out while obtaining the entire Firmware information after SBL Mode.	Unplug and reconnect the AC plug, and try again.
25	Update Error**25	Failed to transit to SBL Mode	Unplug and reconnect the AC plug, and try again.
26	Update Error**26	Time Out in Download (writing to SDRAM) for Firmware Download.	Unplug and reconnect the AC plug, and try again.
27	Update Error**27	Failed to write to EEPROM after SBL Mode.	Unplug and reconnect the AC plug, and try again.
36	Update Error**36	Unable to detect USB.	Reinsert or try a new USB device, Unplug and reconnect the AC plug, and try again.
37	Update Error**37	No Firmware File in USB.	Check the file, Unplug and reconnect the AC plug, and try again.
38	Update Error**38	The Firmware File in the USB does not support your model and area.	Make sure the model name and area of the Firmware File, Unplug and reconnect the AC plug, and try again.
39	Update Error**39	Time Out in USB Check.	Unplug and reconnect the AC plug, and try again.
3A	Update Error**3A	Unable to detect USB for Firmware Download.	Reinsert or try a new USB device, Unplug and reconnect the AC plug, and try again.
3B	Update Error**3B	No Firmware File for Firmware Download.	Check the file, Unplug and reconnect the AC plug, and try again.
3C	Update Error**3C	Error notification received while requesting the Firmware Info.	Try a new USB device, Unplug and reconnect the AC plug, and try again.
3D	Update Error**3D	Time Out while obtaining Firmware information.	Try a new USB device, Unplug and reconnect the AC plug, and try again.
3F	Update Error**3F	Failed to transit to SBL Mode.	Unplug and reconnect the AC plug, and try again.

Error Code	USB Update Error Display	Details of Error code	Remedies
50	Update Error**50	Unable to detect USB.	Reinsert or try a new USB device, Unplug and reconnect the AC plug, and try again.
51	Update Error**51	No Firmware File in USB.	Check the file, Unplug and reconnect the AC plug, and try again.
52	Update Error**52	The Firmware File in the USB does not support your model and area.	Make sure the model name and area of the Firmware File, Unplug and reconnect the AC plug, and try again.
54	Update Error**54	Error notification received while requesting the Firmware Info.	Try a new USB device, Unplug and reconnect the AC plug, and try again.
55	Update Error**55	Time Out while obtaining Firmware information.	Unplug and reconnect the AC plug, and try again.
56	Update Error**56	Unable to detect USB for Firmware Download.	Reinsert or try a new USB device, Unplug and reconnect the AC plug, and try again.
57	Update Error**57	No Firmware File for Firmware Download.	Check the file, Unplug and reconnect the AC plug, and try again.
5A	Update Error**5A	Invalid Device ID in response or no response from Sub for the "C" command.	Unplug and reconnect the AC plug, and try again. If the same error occurs even when it is retried, the device may be malfunctioning.
5B	Update Error**5B	NACK received in response or no response from Sub for the "L" command.	Unplug and reconnect the AC plug, and try again. If the same error occurs even when it is retried, the device may be malfunctioning.
5C	Update Error**5C	No Update Packet received from CY920 (Time Out).	Unplug and reconnect the AC plug, and try again.
5D	Update Error**5D	Abnormal data in Update Packet received from CY920 (CRC Error).	Unplug and reconnect the AC plug, and try again.
5E	Update Error**5E	Abnormal data in Update Packet received from CY920 (Packet No Error).	Unplug and reconnect the AC plug, and try again.
5F	Update Error**5F	Setup failure of the XModem transfer method.	Unplug and reconnect the AC plug, and try again. If the same error occurs even when it is retried, the device may be malfunctioning.

Caution in servicing

Electrical

Mechanical

Repair Information

Updating

Error Code	USB Update Error Display	Details of Error code	Remedies
60	Update Error**60	NACK received in response or no response from Sub for the "P" command.	Unplug and reconnect the AC plug, and try again. If the same error occurs even when it is retried, the device may be malfunctioning.
61	Update Error**61	Mismatched Check Sum in response or no response from Sub for the "I" command.	Unplug and reconnect the AC plug, and try again. If the same error occurs even when it is retried, the device may be malfunctioning.
62	Update Error**62	Failed to start up Sub in Power On sequence during Update.	Unplug and reconnect the AC plug, and try again.
63	Update Error**63	Failed to transit to Application Mode.	Unplug and reconnect the AC plug, and try again.
64	Update Error**64	Failed to transit to Boot Loader Mode.	Unplug and reconnect the AC plug, and try again.
80	Update Error**80	Write Enable Latch Bit not set in Read after issuing the "WREN" command.	Unplug and reconnect the AC plug, and try again. If the same error occurs even when it is retried, the device may be malfunctioning.
81	Update Error**81	Block Erase failed in Read after issuing the "BE" command.	Unplug and reconnect the AC plug, and try again. If the same error occurs even when it is retried, the device may be malfunctioning.
82	Update Error**82	No Update Packet received from CY920 (Time Out).	Unplug and reconnect the AC plug, and try again.
83	Update Error**83	Abnormal data in Update Packet received from CY920 (CRC Error).	Unplug and reconnect the AC plug, and try again.
84	Update Error**84	Abnormal data in Update Packet received from CY920 (Packet No Error).	Unplug and reconnect the AC plug, and try again.
85	Update Error**85	Setup failure of the XModem transfer method	Unplug and reconnect the AC plug, and try again. If the same error occurs even when it is retried, the device may be malfunctioning.
86	Update Error**86	Mismatched Check Sum in Check Sum comparison after rewriting.	Unplug and reconnect the AC plug, and try again.

Error Code	USB Update Error Display	Details of Error code	Remedies
A2	Update Error**A2	Unable to detect USB.	Reinsert or try a new USB device, Unplug and reconnect the AC plug, and try again.
A3	Update Error**A3	No Firmware File in USB.	Check the file, Unplug and reconnect the AC plug, and try again.
A4	Update Error**A4	The Firmware File in the USB does not support your model and area.	Make sure the model name and area of the Firmware File, Unplug and reconnect the AC plug, and try again.
A6	Update Error**A6	Error notification received while requesting the Firmware Info.	Try a new USB device, Unplug and reconnect the AC plug, and try again.
A7	Update Error**A7	Time Out while obtaining Firmware information.	Unplug and reconnect the AC plug, and try again.
AE	Update Error**AE	Unable to detect USB for Firmware Download.	Reinsert or try a new USB device, Unplug and reconnect the AC plug, and try again.
AF	Update Error**AF	No Firmware File for Firmware Download.	Check the file, Unplug and reconnect the AC plug, and try again.
B1	Update Error**B1	Time Out in Download (writing to SDRAM) for Firmware Download.	Unplug and reconnect the AC plug, and try again.
B2	Update Error**B2	Error notification received after rewriting the CY920 Firm.	Unplug and reconnect the AC plug, and try again.
B3	Update Error**B3	Error in Firmware Update (Time Out).	Unplug and reconnect the AC plug, and try again.
B4	Update Error**B4	Failed to transit to Boot Loader Mode.	Unplug and reconnect the AC plug, and try again.
B5	Update Error**B5	Failed to transit to Application Mode.	Unplug and reconnect the AC plug, and try again.

---Checking the Firmware Version After the Update---

After updating the firmware, check the version.

See "1. Version Display Mode"

3. Updating via DPMS

Download the latest firmware from our website and update the firmware.

3.1. Network Connection

(1) System Requirements

- Internet Connection by Broadband Circuit
- Modem
- Router
- Ethernet cable (CAT-5 or greater is recommended)

(2) Setting

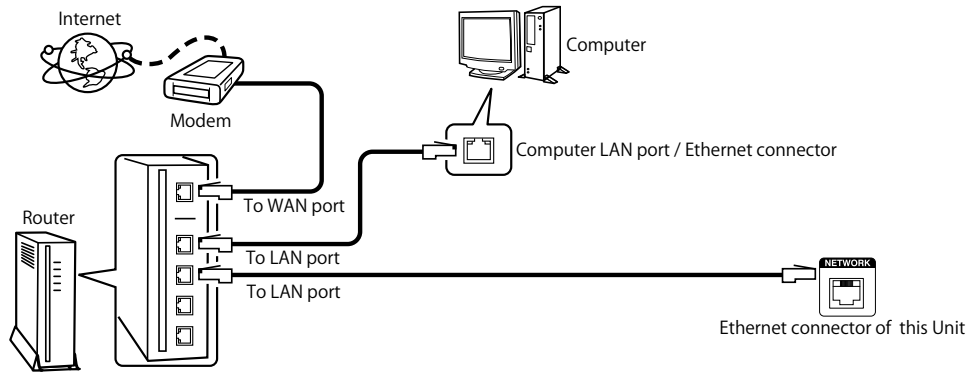

3.2. Check and update the firmware

Check if there is a firmware update available. It is also possible to check approximately how long the update will take.

- (1) Press the **"SETUP"** button on the remote control to display the GUI menu.
- (2) Press the cursor button to select **"General"** → **"Firmware"** → **"Update"** → **"Check for Update"**.
- (3) Press the **"ENTER"** button.
 - The latest version of the firmware uploaded to the web is displayed.
 - If the latest firmware version is on the web, proceed to (4).
 - If the latest firmware is already installed, press the **"SETUP"** button to exit the menu.
- (4) Select **"Start"** using the cursor buttons, and then press **"ENTER"**.
 - The power display lights in red and the GUI screen display disappears during the update. The remaining time of the update is shown on the display of the unit.
 - Returns to the normal status after update is completed.

---Cautions on Firmware Update---

- For the update procedure, a proper broadband Internet connection environment and settings are required.
- Do not turn off the power until updating is completed.
- It takes around 1 hour to complete the update.

Once an update is started, normal operations cannot be performed until it is completed.

The GUI menu settings and image adjustment settings of this unit may be initialized.

Note down the settings before updating, and set them again after updating.

3.3. About the error codes

See the following table for details on the error code display, details of the error code, remedies when updating the firmware via DPMS. (DPMS : D&M Product Management Server)
The error code is displayed as four digits made up of the Device ID below together with **YY (** : Device ID, YY : Error Code).

Device ID	Device Name
00	n/a(※ 1)
01	Main CPU
11	DSP
12	DSP2(※ 2)
13	DSP3(※ 2)
19	DSP4(※ 2)
15	Audio PLD
22	Video PLD
2A	GUI Serial Flash
02	CY920 2nd BootLoader
03	CY920 Image

※ 1 Used when there are no device related errors

※ 2 For SR6011

Error Code	DPMS Update Error Display	Details of Error code	Remedies
01	Update Error**01	Connection to DPMS failed.	Check the network connection, then try again.
03	Update Error**03	Connection to DPMS failed.	Check the network connection, then try again.
04	Update Error**04	Failed to obtain the Firmware information (Device Information)	Check the network connection, then try again.
05	Update Error**05	Time Out while obtaining the Firmware information (Device Information)	Check the network connection, then try again.
06	Update Error**06	Failed to obtain the Firmware information (Package Version)	Check the network connection, then try again.
07	Update Error**07	Time Out while obtaining the Firmware information (Package Version)	Check the network connection, then try again.
08	Update Error**08	Error notification received while requesting the Firmware Info.	Check the network connection, Unplug and reconnect the AC plug, and try again.
09	Update Error**09	Time Out while obtaining Firmware information.	Unplug and reconnect the AC plug, and try again.

Error Code	DPMS Update Error Display	Details of Error code	Remedies
0A	Update Error**0A	Error(NG) notification received while requesting Firmware Download.	Check the network connection, Unplug and reconnect the AC plug, and try again.
0C	Update Error**0C	Error(Connect failure) notification received while requesting Firmware Download.	Check the network connection, Unplug and reconnect the AC plug, and try again.
0D	Update Error**0D	Received value with the invalid Package Version.	Unplug and reconnect the AC plug, and try again.
0E	Update Error**0E	Connection to DPMS failed. (Cannot get NTP)	Check the network connection, then try again.
10	Update Error**10	No Update Packet received from CY920 (Time Out).	Unplug and reconnect the AC plug, and try again.
11	Update Error**11	Abnormal data in Update Packet received from CY920 (CRC Error).	Unplug and reconnect the AC plug, and try again.
12	Update Error**12	Abnormal data in Update Packet received from CY920 (Packet No Error).	Unplug and reconnect the AC plug, and try again.
13	Update Error**13	Failed in Block Erase before rewriting Main.	Unplug and reconnect the AC plug, and try again.
14	Update Error**14	Failed in Block Write while rewriting Main	Unplug and reconnect the AC plug, and try again.
15	Update Error**15	Error in Verify after rewriting Main (Check Sum Error).	Unplug and reconnect the AC plug, and try again.
16	Update Error**16	Setup failure of the XModem transfer method.	Unplug and reconnect the AC plug, and try again. If the same error occurs even when it is retried, the device may be malfunctioning.
20	Update Error**20	After SBL Mode IP Address acquisition failure (AutoIP).	Check the network connection, Unplug and reconnect the AC plug, and try again.
21	Update Error**21	After SBL Mode IP Address acquisition failure (Time Out).	Check the network connection, Unplug and reconnect the AC plug, and try again.
22	Update Error**22	DPMS login incorrect notification after SBL.	Check the network connection, Unplug and reconnect the AC plug, and try again.

Error Code	DPMS Update Error Display	Details of Error code	Remedies
24	Update Error**24	DPMS connection failure notification after SBL.	Check the network connection, Unplug and reconnect the AC plug, and try again.
25	Update Error**25	Failed to transit to SBL Mode.	Unplug and reconnect the AC plug, and try again.
26	Update Error**26	Error in Firmware Download (Time Out).	Unplug and reconnect the AC plug, and try again.
27	Update Error**27	Failed to write to EEPROM after SBL Mode.	Unplug and reconnect the AC plug, and try again.
36	Update Error**36	DPMS login incorrect notification.	Check the network connection, Unplug and reconnect the AC plug, and try again.
38	Update Error**38	DPMS connection failure notification.	Check the network connection, Unplug and reconnect the AC plug, and try again.
39	Update Error**39	DPMS connection Time Out Error.	Unplug and reconnect the AC plug, and try again.
3A	Update Error**3A	Error(NG) notification received while requesting Firmware Download.	Check the network connection, Unplug and reconnect the AC plug, and try again.
3C	Update Error**3C	Error(Connect failure) notification received while requesting Firmware Download.	Check the network connection, Unplug and reconnect the AC plug, and try again.
3D	Update Error**3D	After SBL Mode IP Address acquisition failure (AutoIP).	Check the network connection, Unplug and reconnect the AC plug, and try again.
3E	Update Error**3E	After SBL Mode IP Address acquisition failure (Time Out).	Unplug and reconnect the AC plug, and try again.
3F	Update Error**3F	Failed to transit to SBL Mode.	Unplug and reconnect the AC plug, and try again.
50	Update Error**50	DPMS login incorrect notification.	Check the network connection, Unplug and reconnect the AC plug, and try again.
52	Update Error**52	DPMS connection failure notification.	Check the network connection, Unplug and reconnect the AC plug, and try again.

Error Code	DPMS Update Error Display	Details of Error code	Remedies
54	Update Error**54	Error notification received while requesting the Firmware Info.	Check the network connection, Unplug and reconnect the AC plug, and try again.
55	Update Error**55	Time Out while obtaining Firmware information.	Unplug and reconnect the AC plug, and try again.
56	Update Error**56	Error(NG) notification received while requesting Firmware Download.	Check the network connection, Unplug and reconnect the AC plug, and try again.
58	Update Error**58	Error(Connect failure) notification received while requesting Firmware Download.	Check the network connection, Unplug and reconnect the AC plug, and try again.
5A	Update Error**5A	Invalid Device ID in response or no response from Sub for the "C" command.	Unplug and reconnect the AC plug, and try again. If the same error occurs even when it is retried, the device may be malfunctioning.
5B	Update Error**5B	NACK received in response or no response from Sub for the "L" command.	Unplug and reconnect the AC plug, and try again. If the same error occurs even when it is retried, the device may be malfunctioning.
5C	Update Error**5C	No Update Packet received from CY920 (Time Out).	Unplug and reconnect the AC plug, and try again.
5D	Update Error**5D	Abnormal data in Update Packet received from CY920 (CRC Error).	Unplug and reconnect the AC plug, and try again.
5E	Update Error**5E	Abnormal data in Update Packet received from CY920 (Packet No Error).	Unplug and reconnect the AC plug, and try again.
5F	Update Error**5F	Setup failure of the XModem transfer method.	Unplug and reconnect the AC plug, and try again. If the same error occurs even when it is retried, the device may be malfunctioning.
60	Update Error**60	NACK received in response or no response from Sub for the "P" command.	Unplug and reconnect the AC plug, and try again. If the same error occurs even when it is retried, the device may be malfunctioning.
61	Update Error**61	Mismatched Check Sum in response or no response from Sub for the "I" command.	Unplug and reconnect the AC plug, and try again. If the same error occurs even when it is retried, the device may be malfunctioning.

Caution in servicing

Electrical

Mechanical

Repair Information

Updating

Error Code	DPMS Update Error Display	Details of Error code	Remedies
62	Update Error**62	Failed to start up Sub in Power On sequence during Update.	Unplug and reconnect the AC plug, and try again.
80	Update Error**80	Write Enable Latch Bit not set in Read after issuing the "WREN" command.	Unplug and reconnect the AC plug, and try again. If the same error occurs even when it is retried, the device may be malfunctioning.
81	Update Error**81	Block Erase failed in Read after issuing the "BE" command.	Unplug and reconnect the AC plug, and try again. If the same error occurs even when it is retried, the device may be malfunctioning.
82	Update Error**82	No Update Packet received from CY920 (Time Out).	Unplug and reconnect the AC plug, and try again.
83	Update Error**83	Abnormal data in Update Packet received from CY920 (CRC Error).	Unplug and reconnect the AC plug, and try again.
84	Update Error**84	Abnormal data in Update Packet received from CY920 (PacketNoError).	Unplug and reconnect the AC plug, and try again.
85	Update Error**85	Setup failure of the XModem transfer method.	Unplug and reconnect the AC plug, and try again. If the same error occurs even when it is retried, the device may be malfunctioning.
86	Update Error**86	Mismatched Check Sum in Check Sum comparison after rewriting.	Unplug and reconnect the AC plug, and try again.
A0	Update Error**A0	IP Address acquisition failure (AutoIP).	Check the network connection, Unplug and reconnect the AC plug, and try again.
A1	Update Error**A1	IP Address acquisition failure (Time Out).	Unplug and reconnect the AC plug, and try again.
A2	Update Error**A2	DPMS login incorrect notification.	Check the network connection, Unplug and reconnect the AC plug, and try again.
A4	Update Error**A4	DPMS connection failure notification.	Check the network connection, Unplug and reconnect the AC plug, and try again.
A6	Update Error**A6	Error notification received while requesting the Firmware Info.	Check the network connection, Unplug and reconnect the AC plug, and try again.

Error Code	DPMS Update Error Display	Details of Error code	Remedies
A7	Update Error**A7	Time Out while obtaining Firmware information.	Unplug and reconnect the AC plug, and try again.
AE	Update Error**AE	Error(NG) notification received while requesting Firmware Download.	Check the network connection, Unplug and reconnect the AC plug, and try again.
B0	Update Error**B0	Error(Connect failure) notification received while requesting Firmware Download.	Check the network connection, Unplug and reconnect the AC plug, and try again.
B1	Update Error**B1	Error in Firmware Download (Time Out).	Check the network connection, Unplug and reconnect the AC plug, and try again.
B2	Update Error**B2	Error notification received after rewriting the CY920 Firm.	Unplug and reconnect the AC plug, and try again.
B3	Update Error**B3	Error in Firmware Update (Time Out).	Unplug and reconnect the AC plug, and try again.
B4	Update Error**B4	Failed to transit to Boot Loader Mode.	Unplug and reconnect the AC plug, and try again.
B5	Update Error**B5	Failed to transit to Application Mode.	Unplug and reconnect the AC plug, and try again.

---Checking the Firmware Version After the Update---

After updating the firmware, check the version.

See "1. Version Display Mode"

DENON
www.denon.com

Copyright 2016 D&M Holdings Inc. All rights reserved.

FRONT PCB ASS'Y

※Parts indicated by "nsp" on this table cannot be supplied. Part indicated by "@" mark is not illustrated in the exploded view

※The parts listed below are only for maintenance. Therefore they might differ from the parts used in the unit in appearances or dimensions

NOTE:The symbols in the column Remarks indicate the following destinations.

E3 : U.S.A. & Canada model E2 : Europe model E1C : China model E1 : Asia model JP : Japan model

BK : Black model SP : Premium Silver model

REF No.	Part No.	Part Name	Remarks	Q'ty	New	Ver
SEMICONDUCTORS GROUP						
D1001	943203500730S	DIODE,RECTIFIER,AXIAL		1	*	
D1002	00D9430182609	DIODE,SWITCHING	E3	1		
D1003	943202501110S	DIODE,ZENER,1/2W,6.8V		1	*	
D1004	nsp	EOLitemWIRE,COPPER(D0.6)		0.02		
D1005	943202501120S	DIODE,ZENER,1/2W,39V		1	*	
D1008	963209003510S	DIODE,RELIABLEESDPROTECTION		1		
D1009	963209003510S	DIODE,RELIABLEESDPROTECTION		1		
D1010	963209003510S	DIODE,RELIABLEESDPROTECTION		1		
D1011	963209003510S	DIODE,RELIABLEESDPROTECTION		1		
D1012	943176010090S	L.E.D.(GREEN/RED5PI)	S720, E2, E1C, JP	1		
D1012	963263100960S	LED,WHITE/RED	E3	1		
D1019	201310001503S	DIODE,ULTRA-HIGHSPEED		1		
D1020	201310001503S	DIODE,ULTRA-HIGHSPEED		1		
D1401	943202501130S	DIODE,ZENER,1/2W,5.1V		1	*	
D1402	943202501130S	DIODE,ZENER,1/2W,5.1V		1	*	
D1403	943202501130S	DIODE,ZENER,1/2W,5.1V		1	*	
D1404	201310001503S	DIODE,ULTRA-HIGHSPEED		1		
D1405	201310001503S	DIODE,ULTRA-HIGHSPEED		1		
IC101	943232100540S	I.C.DUALOPAMP(SOP-8P)		1	*	
Q1001	943219006820S	T.R		1		
Q1002	943216500020S	T.R,RT1N141C(10K-10K)		1		
Q1003	943214500020S	T.R,2SC3052		1		
Q1004	943214500020S	T.R,2SC3052		1		
Q1005	963212500030S	T.R,ISA1530AC1		1		
Q1006	943216500020S	T.R,RT1N141C(10K-10K)		1		
Q1007	943215500020S	T.R,RT1P141C(10K-10K)		1		
Q1008	943215500020S	T.R,RT1P141C(10K-10K)		1		
Q1009	943216500020S	T.R,RT1N141C(10K-10K)		1		
Q1011	943215500020S	T.R,RT1P141C(10K-10K)		1		
Q1012	943216500020S	T.R,RT1N141C(10K-10K)		1		
Q1013	943216500020S	T.R,RT1N141C(10K-10K)		1		
Q1014	943219006820S	T.R		1		
Q1015	943216500050S	T.R,RT1N441C(47K-47K)		1		
Q1016	943214500020S	T.R,2SC3052		1		
RESISTOR GROUP						
R1001	nsp	RES,CARBON(1/5W,1.8ohm,J)		1		
R1004	nsp	RES,CARBON(1/5W,1.8ohm,J)		1		
R1005	nsp	RES,CHIP(1608/5%/220ohm)		1		
R1006	nsp	RES,CHIP(1608/5%/220ohm)		1		
R1007	nsp	RES,CARBON(1/5W,10Kohm,J)		1		
R1008	nsp	RES,CHIP(1608/5%/220ohm)		1		
R1009	nsp	RES,CHIP(1608/5%/220ohm)		1		
R1010	nsp	RES,CHIP(1608/5%/39Kohm)		1		
R1011	nsp	RES,CHIP(1608/5%/10Kohm)		1		
R1012	nsp	RES,CHIP(1608/5%/100ohm)		1		
R1013	nsp	RES,CHIP(1608/5%/100ohm)		1		
R1014	nsp	RES,CHIP(1608/5%/100ohm)		1		
R1015	nsp	RES,CHIP(1608/5%/100ohm)		1		
R1016	nsp	RES,CHIP(1608/5%/100Kohm)		1		
R1017	nsp	RES,CHIP(1608/5%/100Kohm)		1		
R1018	nsp	RES,CHIP(1608/5%/100ohm)		1		
R1019	nsp	RES,CHIP(1608/5%/100ohm)		1		
R1020	nsp	RES,CHIP(1608/5%/3.3Kohm)		1		
R1021	nsp	RES,CHIP(1608/5%/1Kohm)		1		
R1022	nsp	RES,CHIP(1608/5%/1Kohm)		1		
R1023	nsp	RES,CHIP(1608/5%/47Kohm)		1		
R1025	nsp	RES,CHIP(1608/5%/39Kohm)		1		
R1026	nsp	RES,CHIP(1608/5%/39Kohm)		1		
R1027	nsp	RES,CHIP(1608/5%/4.7Kohm)		1		
R1030	nsp	RES,CARBON(1/5W,10ohm,J)		1		
R1040	nsp	RES,CHIP(1608/5%/2.2Kohm)		1		
R1041	nsp	RES,CHIP(1608/5%/1.2Kohm)		1		
R1042	nsp	RES,CHIP(1608/5%/1.2Kohm)		1		
R1043	nsp	RES,CHIP(1608/5%/4.7Kohm)		1		
R1053	nsp	RES,CHIP(1608/5%/10ohm)		1		
R1057	nsp	RES,CHIP(1608/5%/470ohm)		1		
R1058	nsp	RES,CHIP(1608/5%/1Kohm)		1		
R1059	nsp	RES,CHIP(1608/5%/1Kohm)		1		
R1060	nsp	RES,CHIP(1608/5%/10Kohm)		1		
R1061	nsp	RES,CHIP(1608/5%/10Kohm)		1		
R1067	nsp	RES,CARBON(1/5W,10ohm,J)		1		
R1071	nsp	RES,CHIP(1608/5%/330ohm)	S720	1		
R1072	nsp	RES,CHIP(1608/5%/220ohm)	S720	1		
R1073	nsp	RES,CHIP(1608/5%/180ohm)	S720	1		
R1073	nsp	RES,CHIP(1608/5%/150ohm)	E3, E2, E1C, JP	1		
R1074	nsp	RES,CHIP(1608/5%/150ohm)	S720	1		
R1074	nsp	RES,CHIP(1608/5%/100ohm)	E3, E2, E1C, JP	1		
R1075	nsp	RES,CHIP(1608/5%/100ohm)	S720	1		
R1075	nsp	RES,CHIP(1608/5%/0ohm)	E3, E2, E1C, JP	1		
R1076	nsp	RES,CHIP(1608/5%/330ohm)	S720	1		
R1077	nsp	RES,CHIP(1608/5%/220ohm)	S720	1		
R1077	nsp	RES,CHIP(1608/5%/150ohm)	E3, E2, E1C, JP	1		
R1078	nsp	RES,CHIP(1608/5%/180ohm)	S720	1		
R1078	nsp	RES,CHIP(1608/5%/100ohm)	E3, E2, E1C, JP	1		
R1079	nsp	RES,CHIP(1608/5%/150ohm)	S720	1		
R1079	nsp	RES,CHIP(1608/5%/0ohm)	E3, E2, E1C, JP	1		
R1080	nsp	RES,CHIP(1608/5%/100ohm)	S720	1		
R1080	nsp	RES,CHIP(1608/5%/0ohm)	E3, E2, E1C, JP	1		
R1081	nsp	RES,CHIP(1608/5%/330ohm)	S720	1		
R1082	nsp	RES,CHIP(1608/5%/220ohm)	S720	1		
R1082	nsp	RES,CHIP(1608/5%/180ohm)	E3, E2, E1C, JP	1		
R1083	nsp	RES,CHIP(1608/5%/180ohm)	S720	1		
R1083	nsp	RES,CHIP(1608/5%/150ohm)	E3, E2, E1C, JP	1		
R1084	nsp	RES,CHIP(1608/5%/150ohm)	S720	1		
R1084	nsp	RES,CHIP(1608/5%/100ohm)	E3, E2, E1C, JP	1		
R1085	nsp	RES,CHIP(1608/5%/100ohm)	S720	1		
R1085	nsp	RES,CHIP(1608/5%/0ohm)	E3, E2, E1C, JP	1		
R1401	nsp	RES,CHIP(1608/5%/100ohm)		1		
R1402	nsp	RES,CHIP(1608/5%/100Kohm)		1		
R1403	nsp	RES,CHIP(1608/5%/100Kohm)		1		
R1404	nsp	RES,CHIP(1608/5%/100Kohm)		1		
R1405	nsp	RES,CHIP(1608/5%/2.2Kohm)		1		
R1406	nsp	RES,CHIP(1608/5%/100ohm)		1		
R1407	nsp	RES,CHIP(1608/5%/820ohm)		1		
R1408	nsp	RES,CHIP(1608/5%/18Kohm)		1		

REF No.	Part No.	Part Name	Remarks	Q'ty	New	Ver
R1409	nsp	RES.CHIP(1608/5%/100ohm)		CRJ10DJ101T	1	
R1410	nsp	RES.CHIP(1608/5%/47Kohm)		CRJ10DJ473T	1	
R1411	nsp	RES.CHIP(1608/5%/2.2Kohm)		CRJ10DJ222T	1	
R1413	nsp	RES.CHIP(1608/5%/10Kohm)		CRJ10DJ103T	1	
R1414	nsp	RES.CHIP(1608/5%/10Kohm)		CRJ10DJ103T	1	
R1415	nsp	RES.CHIP(1608/5%/1Kohm)		CRJ10DJ102T	1	
R1416	nsp	RES.CHIP(1608/5%/1Kohm)		CRJ10DJ102T	1	
R1418	nsp	RES.CHIP(1608/5%/390ohm)	E3	CRJ10DJ391T	1	
R1419	nsp	RES.CHIP(1608/5%/390ohm)	E3	CRJ10DJ391T	1	
R1420	nsp	RES.CHIP(1608/5%/47Kohm)	E3	CRJ10DJ473T	1	
R1423	nsp	RES.CARBON(1/5W,47Kohm,J)		CRD20TJ473T	1	
R1424	nsp	RES.CARBON(1/4W,27Kohm,J)		CRD25TJ273T	1	
R1425	nsp	RES.M-OXIDEFILM(1W/10ohm)		CRG1SANJ100RT	1	
R1426	nsp	RES.M-OXIDEFILM(1W/10ohm)		CRG1SANJ100RT	1	
R1428	nsp	RES.CHIP(1608/5%/220Kohm)		CRJ10DJ224T	1	
R1429	nsp	RES.CHIP(1608/5%/10Kohm)		CRJ10DJ103T	1	
R1430	nsp	RES.CHIP(1608/5%/22Kohm)		CRJ10DJ223T	1	
CAPACITORS GROUP						
C1002	nsp	CAP.MYLAR(50V/0.1uF/J)		HCQ1H104JZT	1	
C1003	nsp	CAP.ELECT(50V/10uF)-S		CCEA1HKS100T	1	
C1004	nsp	CAP.ELECT(50V/1uF)		CCEA1HH1R0T	1	
C1005	nsp	CAP.ELECT(63V/100uF)		CCEA1JH101E	1	
C1006	nsp	CAP.ELECT(50V/1uF)		CCEA1HH1R0T	1	
C1007	nsp	CAP.METAL-FILM(100V/0.047uF)		CGME2A473JXT	1	
C1009	nsp	CAP.CHIP(2012.50V/0.1uF.X7R)_SAMSUNG		CCUC1H104KCS	1	
C1010	nsp	CAP.ELECT(16V/47uF)-S		CCEA1CKS470T	1	
C1011	nsp	CAP.CHIP(1608.50V/0.1uF.X7R)_SAMSUNG		CCUS1H104KCS	1	
C1013	nsp	CAP.CHIP(1608.50V/100pF.CO0)_SAMSUNG		CCUS1H101JAS	1	
C1014	nsp	CAP.CHIP(1608.50V/100pF.CO0)_SAMSUNG		CCUS1H101JAS	1	
C1015	nsp	CAP.CHIP(1608.50V/330pF.CO0)_SAMSUNG		CCUS1H331JAS	1	
C1016	nsp	CAP.CHIP(1608.50V/1000pF.X7R)_SAMSUNG		CCUS1H102KCS	1	
C1017	nsp	CAP.METAL-FILM(100V/0.047uF)		CGME2A473JXT	1	
C1019	nsp	CAP.ELECT(50V/10uF)		CCEA1HH100T	1	
C1020	nsp	CAP.CHIP(1608.50V/0.01uF.X7R)_SAMSUNG		CCUS1H103KCS	1	
C1038	nsp	CAP.ELECT(16V/47uF)-S		CCEA1CKS470T	1	
C1039	nsp	CAP.CHIP(1608.50V/100pF.CO0)_SAMSUNG		CCUS1H101JAS	1	
C1050	nsp	CAP.CHIP(1608.50V/0.1uF.X7R)_SAMSUNG		CCUS1H104KCS	1	
C1052	nsp	CAP.ELECT(10V/220uF)-S		CCEA1AKS221T	1	
C1053	nsp	CAP.CHIP(1608.50V/0.1uF.X7R)_SAMSUNG		CCUS1H104KCS	1	
C1054	nsp	CAP.CHIP(1608.50V/0.1uF.X7R)_SAMSUNG		CCUS1H104KCS	1	
C1055	nsp	CAP.CHIP(1608.50V/0.1uF.X7R)_SAMSUNG		CCUS1H104KCS	1	
C1065	nsp	CAP.ELECT(50V/1uF)		CCEA1HH1R0T	1	
C1066	nsp	CAP.CHIP(1608.50V/0.1uF.X7R)_SAMSUNG		CCUS1H104KCS	1	
C1067	nsp	CAP.ELECT(50V/1uF)		CCEA1HH1R0T	1	
C1068	nsp	CAP.CHIP(1608.50V/0.1uF.X7R)_SAMSUNG		CCUS1H104KCS	1	
C1071	nsp	CAP.CHIP(1608.50V/680pF.CO0)_SAMSUNG		CCUS1H681JAS	1	
C1072	nsp	CAP.CHIP(1608.50V/680pF.CO0)_SAMSUNG		CCUS1H681JAS	1	
C1073	nsp	CAP.CHIP(1608.50V/0.1uF.X7R)_SAMSUNG		CCUS1H104KCS	1	
C1076	nsp	CAP.CHIP(1608.50V/0.01uF.X7R)_SAMSUNG		CCUS1H103KCS	1	
C1077	nsp	CAP.CHIP(1608.50V/0.01uF.X7R)_SAMSUNG		CCUS1H103KCS	1	
C1081	nsp	CAP.CHIP(1608.50V/0.1uF.X7R)_SAMSUNG		CCUS1H104KCS	1	
C1401	nsp	CAP.CHIP(1608.50V/0.1uF.X7R)_SAMSUNG		CCUS1H104KCS	1	
C1402	nsp	CAP.ELECT(50V/1uF)-S		CCEA1HKS1R0T	1	
C1403	nsp	CAP.CHIP(1608.50V/100pF.CO0)_SAMSUNG		CCUS1H101JAS	1	
C1405	nsp	CAP.ELECT(50V/10uF)-S		CCEA1HKS100T	1	
C1406	nsp	CAP.CHIP(1608.50V/0.047uF.X7R)_SAMSUNG		CCUS1H473KCS	1	
C1407	nsp	CAP.ELECT(16V/100uF)-S		CCEA1CKS101T	1	
C1408	nsp	CAP.CHIP(1608.50V/82pF.CO0)_SAMSUNG		CCUS1H820JAS	1	
C1410	nsp	CAP.ELECT(50V/1uF)-S		CCEA1HKS1R0T	1	
C1411	nsp	CAP.ELECT(50V/1uF)-S		CCEA1HKS1R0T	1	
C1414	nsp	CAP.CHIP(1608.50V/0.1uF.X7R)_SAMSUNG		CCUS1H104KCS	1	
C1415	nsp	CAP.CHIP(1608.50V/1000pF.X7R)_SAMSUNG		CCUS1H102KCS	1	
C1417	nsp	CAP.CHIP(1608.50V/0.1uF.X7R)_SAMSUNG		CCUS1H104KCS	1	
C1424	nsp	CAP.CHIP(1608.50V/0.1uF.X7R)_SAMSUNG		CCUS1H104KCS	1	
C1425	nsp	CAP.CHIP(1608.50V/0.01uF.X7R)_SAMSUNG		CCUS1H103KCS	1	
C1426	nsp	CAP.CHIP(1608.50V/0.01uF.X7R)_SAMSUNG		CCUS1H103KCS	1	
OTHER PARTS GROUP						
BK101	nsp	BRACKET_FIP		CMD1A572-V1	1	
BK102	nsp	BRACKET_FIP		CMD1A572-V1	1	
BN101	nsp	WIREASS'YB'D-B'DIN(9P,2MM,80MM,#28)		CWB1A009080CC	1	
BN104	nsp	WIREASS'YLocking(YH,5P,2.0MM,330MM,#24)		CWB1C205330HC001	1	
BN12A	nsp	WIREASS'YB'DtoB'D(CKM)(5P,2MM,80MM,#26)		CWB1B005080CC	1	
BN12B1	nsp	WAFER,FFC1.25mm,ANGLE		CJP27GB296ZN	1	
BN131	nsp	WIREASS'YLocking(YH)(3P,2MM,50MM,#28)		CWB1A003050HC	1	
CN102	nsp	WAFER/ANGLE/2.5mm/07P		CJP07GB03ZY	1	
CN103	nsp	LOCK-WAFER/ANGLE/2MMPITCH/3PIN		CJP03GJ288ZY	1	
CN104	nsp	LOCK-WAFER/STRAIGHT/2MMPITCH/3PIN		CJP03GI288ZY	1	
! F1001	943652500600S	FUSE(932Series,250V/200mA)	S720,E3	CBA2J0200TLUBT	1	
! F1001	943652500550D	FUSE(372Series/200mA/TR5)	E2, E1C, JP	CBA2D0200A3EYT	1	
FL101	943172100150S	V.F.D(FUTABA,18-BT-02GINK)		CFL18BT021GINK	1	
J1056	nsp	EOLitemWIRE,COPPER(D0.6)	S720	C3A206	0.03	
J1057	nsp	EOLitemWIRE,COPPER(D0.6)	S720	C3A206	0.02	
J1059	nsp	EOLitemWIRE,COPPER(D0.6)	S720	C3A206	0.02	
J1061	nsp	EOLitemWIRE,COPPER(D0.6)	S720	C3A206	0.02	
J1064	nsp	EOLitemWIRE,COPPER(D0.6)	S720	C3A206	0.03	
JK101	943643101590S	JACK,USBSTRAIGHT(BLACK1.5A)		CJ9X010Z	1	
JK104	90M-YT004500R	JACK,PHONES(6.35mm,SILVER)		CJJE026Z	1	
JK105	943643102930S	JACK,STEREO,3.5mmMINI,BLACKMOLD		CJJ2D029Z	1	
L1001	nsp	FERRITECHIPBEAD(1608/60R,CB03YTYH600)		CLZ9R005V	1	
L1003	nsp	FERRITECHIPBEAD(4516/60R)		CLZ9Z014V	1	
L1004	nsp	RES.CHIP(1608/5%/0ohm)		CRJ10DJ0R0T	1	
L1005	nsp	RES.CHIP(1608/5%/0ohm)		CRJ10DJ0R0T	1	
L1010	nsp	FERRITECHIPBEAD(1608/60R,CB03YTYH600)		CLZ9R005V	1	
L1011	nsp	FERRITECHIPBEAD(1608/60R,CB03YTYH600)		CLZ9R005V	1	
L1012	nsp	FERRITECHIPBEAD(1608/60R,CB03YTYH600)		CLZ9R005V	1	
L1013	nsp	FERRITECHIPBEAD(1608/60R,CB03YTYH600)		CLZ9R005V	1	
L1401	nsp	FERRITECHIPBEAD(1608/60R,CB03YTYH600)		CLZ9R005V	1	
L1402	nsp	FERRITECHIPBEAD(1608/60R,CB03YTYH600)		CLZ9R005V	1	
L1403	nsp	FERRITECHIPBEAD(1608/60R,CB03YTYH600)		CLZ9R005V	1	
L1404	nsp	FERRITECHIPBEAD(1608/60R,CB03YTYH600)		CLZ9R005V	1	
LD101	963262010460S	L.E.D(Infraredlightemittingdiode)	E3	CVDSIR341ST3FT0	1	
LUG11	nsp	WIREASS'Y		CWE8102100RV	1	
LUG13	nsp	WIREASS'Y		CWE8102180RV	1	
RC101	943262100140S	SENSOR,REMOTE(37.9KHz)		CRVHM238RT12	1	
SW101	00D9430004402	SW,TACT		CST1A0122T	1	
SW102	00D9430004402	SW,TACT	S720	CST1A0122T	1	
SW103	00D9430004402	SW,TACT	S720	CST1A0122T	1	
SW104	00D9430004402	SW,TACT		CST1A0122T	1	
SW105	00D9430004402	SW,TACT		CST1A0122T	1	
SW106	00D9430004402	SW,TACT		CST1A0122T	1	
SW107	00D9430004402	SW,TACT	S720	CST1A0122T	1	
SW108	00D9430004402	SW,TACT	S720	CST1A0122T	1	
SW109	00D9430004402	SW,TACT		CST1A0122T	1	

REF No.	Part No.	Part Name	Remarks		Q'ty	New	Ver
SW110	00D9430004402	SW,TACT		CST1A012ZT	1		
SW111	00D9430004402	SW,TACT		CST1A012ZT	1		
SW112	00D9430004402	SW,TACT	S720	CST1A012ZT	1		
SW113	00D9430004402	SW,TACT	S720	CST1A012ZT	1		
SW114	00D9430004402	SW,TACT	S720	CST1A012ZT	1		
SW115	00D9430004402	SW,TACT		CST1A012ZT	1		
SW116	00D9430004402	SW,TACT		CST1A012ZT	1		
SW117	00D9430004402	SW,TACT		CST1A012ZT	1		
SW118	00D9430004402	SW,TACT		CST1A012ZT	1		
SW119	00D9430004402	SW,TACT	S720	CST1A012ZT	1		
VR101	943671010330S	ENCODER(16MM,24PULSES),W/CLICK		CSR2A055Z	1		
VR102	943671101000D	ENCODER(16MM,12PULSES)		CSR2A060Z	1		

F-HDMI PCB ASS'Y

※Parts indicated by "nsp" on this table cannot be supplied. Part indicated by "@" mark is not illustrated in the exploded view

※The parts listed below are only for maintenance. Therefore they might differ from the parts used in the unit in appearances or dimensions

NOTE: The symbols in the column Remarks indicate the following destinations.

E3 : U.S.A. & Canada model E2 : Europe model E1C : China model E1 : Asia model JP : Japan model

BK : Black model SP : Premium Silver model

REF No.	Part No.	Part Name	Remarks	Q'ty	New	Ver
SEMICONDUCTORS GROUP						
D8103	00D2760718902	DIODE,SCHOTTKY,30V		CVDRB521S-30	1	
IC811	963236101380P	I.C.HDMI BUFFER		CVIAD8195ACPZ	1	
Q8101	943215500020S	T.R,RT1P141C(10K-10K)		CVTRT1P141C	1	
Q8102	943216500040S	T.R,RT1N241C(22K-22K)		CVTRT1N241C	1	
RESISTOR GROUP						
R8102	nsp	RES,CHIP(1005/5%/1Kohm)		CRJ061J102T	1	
R8103	nsp	RES,CHIP(1005/5%/22Kohm)		CRJ061J223T	1	
R8104	nsp	RES,CHIP(1005/5%/47Kohm)		CRJ061J473T	1	
R8105	nsp	RES,CHIP(1005/5%/0ohm)		CRJ061J0R0T	1	
R8107	nsp	RES,CHIP(1005/5%/47Kohm)		CRJ061J473T	1	
R8108	nsp	RES,CHIP(1005/5%/0ohm)		CRJ061J0R0T	1	
R8111	nsp	RES,CHIP(1005/5%/2Kohm)		CRJ061J202T	1	
R8117	nsp	RES,CHIP(1608/5%/0ohm)		CRJ10DJ0R0T	1	
R8118	nsp	RES,CHIP(1608/5%/0ohm)		CRJ10DJ0R0T	1	
R8120	nsp	RES,CHIP(1608/5%/0ohm)		CRJ10DJ0R0T	1	
R8121	nsp	RES,CHIP(1608/5%/0ohm)		CRJ10DJ0R0T	1	
R8123	nsp	RES,CHIP(1005/5%/4.7Kohm)		CRJ061J472T	1	
R8126	nsp	RES,CHIP(1005/5%/2Kohm)		CRJ061J202T	1	
R8127	nsp	RES,CHIP(1005/5%/2Kohm)		CRJ061J202T	1	
R8128	nsp	RES,CHIP(1005/5%/0ohm)		CRJ061J0R0T	1	
CAPACITORS GROUP						
C8101	nsp	CAP,CHIP(1005,16V/0.1uF,X7R)_SAMSUNG		CCU1C104KCS	1	
C8102	nsp	CAP,CHIP(1005,16V/0.1uF,X7R)_SAMSUNG		CCU1C104KCS	1	
C8103	nsp	CAP,CHIP(1005,16V/0.1uF,X7R)_SAMSUNG		CCU1C104KCS	1	
C8104	nsp	CAP,CHIP(1005,16V/0.1uF,X7R)_SAMSUNG		CCU1C104KCS	1	
C8105	nsp	CAP,CHIP(1005,16V/0.1uF,X7R)_SAMSUNG		CCU1C104KCS	1	
C8108	nsp	CAP,CHIP(1005,16V/0.1uF,X7R)_SAMSUNG		CCU1C104KCS	1	
C8109	nsp	CAP,CHIP(1005,16V/0.1uF,X7R)_SAMSUNG		CCU1C104KCS	1	
C8110	nsp	CAP,CHIP(1005,16V/0.1uF,X7R)_SAMSUNG		CCU1C104KCS	1	
C8111	nsp	CAP,CHIP(1005,16V/0.1uF,X7R)_SAMSUNG		CCU1C104KCS	1	
C8112	nsp	CAP,CHIP(2012,6.3V/10uF,X5R)_SAMSUNG		CCUC0J106KCS	1	
C8113	nsp	CAP,CHIP(1005,16V/0.1uF,X7R)_SAMSUNG		CCU1C104KCS	1	
C8114	nsp	CAP,CHIP(1005,16V/0.1uF,X7R)_SAMSUNG		CCU1C104KCS	1	
C8115	nsp	CAP,CHIP(1005,16V/0.1uF,X7R)_SAMSUNG		CCU1C104KCS	1	
C8116	nsp	CAP,CHIP(1005,16V/0.1uF,X7R)_SAMSUNG		CCU1C104KCS	1	
C8117	nsp	CAP,CHIP(1005,16V/0.1uF,X7R)_SAMSUNG		CCU1C104KCS	1	
C8118	nsp	CAP,CHIP(1005,16V/0.1uF,X7R)_SAMSUNG		CCU1C104KCS	1	
C8119	nsp	CAP,CHIP(1005,16V/0.1uF,X7R)_SAMSUNG		CCU1C104KCS	1	
C8120	nsp	CAP,CHIP(1005,16V/0.1uF,X7R)_SAMSUNG		CCU1C104KCS	1	
C8121	nsp	CAP,CHIP(1005,16V/0.1uF,X7R)_SAMSUNG		CCU1C104KCS	1	
C8122	nsp	CAP,CHIP(2012,6.3V/10uF,X5R)_SAMSUNG		CCUC0J106KCS	1	
C8127	nsp	CAP,CHIP(1005,16V/0.1uF,X7R)_SAMSUNG		CCU1C104KCS	1	
C8128	nsp	CAP,CHIP(2012,6.3V/10uF,X5R)_SAMSUNG		CCUC0J106KCS	1	
C8134	nsp	CAP,CHIP(1005,25V/0.01uF,X7R)_SAMSUNG		CCU1E103KCS	1	
OTHER PARTS GROUP						
BK871	nsp	PLATE,EARTH HDMI B		VMC1A422	1	
CN811	nsp	WAFER,FFC(23PIN,1mm STRAIGHT)		CJP23GA333ZR	1	
JK811	943643102920S	JACK,HDMI(TYPE-A,SMT-19P,WITH FLANGE)		CJJ9H021Z	1	
L8101	nsp	FERRITE CHIP BEAD(1608/60R,CB03YTYH600)		CLZ9R005V	1	
L8102	nsp	FERRITE CHIP BEAD(1608/60R,CB03YTYH600)		CLZ9R005V	1	
L8111	nsp	RES,CHIP(1005/5%/0ohm*2)		CRJ062J0R0T	1	
L8112	nsp	RES,CHIP(1005/5%/0ohm*2)		CRJ062J0R0T	1	
L8113	nsp	RES,CHIP(1005/5%/0ohm*2)		CRJ062J0R0T	1	
L8114	nsp	RES,CHIP(1005/5%/0ohm*2)		CRJ062J0R0T	1	
L8115	nsp	RES,CHIP(1005/5%/0ohm*2)		CRJ062J0R0T	1	
L8116	nsp	RES,CHIP(1005/5%/0ohm*2)		CRJ062J0R0T	1	
L8117	nsp	RES,CHIP(1005/5%/0ohm*2)		CRJ062J0R0T	1	
L8118	nsp	RES,CHIP(1005/5%/0ohm*2)		CRJ062J0R0T	1	

DIFF-AMP PCB ASS'Y

※Parts indicated by "nsp" on this table cannot be supplied. Part indicated by "@" mark is not illustrated in the exploded view
 ※The parts listed below are only for maintenance. Therefore they might differ from the parts used in the unit in appearances or dimensions
 NOTE:The symbols in the column Remarks indicate the following destinations.
 E3 : U.S.A. & Canada model E2 : Europe model E1C : China model E1 : Asia model JP : Japan model
 BK : Black model SP : Premium Silver model

REF No.	Part No.	Part Name	Remarks	Q'ty	New	Ver
SEMICONDUCTORS GROUP						
Q2101	943211500150S	PNP,TO-92,LOWNOISE,HFE:300-600,FAILCHILD		1		
Q2102	943211500150S	PNP,TO-92,LOWNOISE,HFE:300-600,FAILCHILD		1		
Q2103	943213500150S	NPN,TO-92,LOWNOISE,HFE:300-600,FAILCHILD		1		
Q2104	90M-HT800120R	T,R,BIAS		7		
Q2201	943211500150S	PNP,TO-92,LOWNOISE,HFE:300-600,FAILCHILD		1		
Q2202	943211500150S	PNP,TO-92,LOWNOISE,HFE:300-600,FAILCHILD		1		
Q2203	943213500150S	NPN,TO-92,LOWNOISE,HFE:300-600,FAILCHILD		1		
Q2301	943211500150S	PNP,TO-92,LOWNOISE,HFE:300-600,FAILCHILD		1		
Q2302	943211500150S	PNP,TO-92,LOWNOISE,HFE:300-600,FAILCHILD		1		
Q2303	943213500150S	NPN,TO-92,LOWNOISE,HFE:300-600,FAILCHILD		1		
Q2401	943211500150S	PNP,TO-92,LOWNOISE,HFE:300-600,FAILCHILD		1		
Q2402	943211500150S	PNP,TO-92,LOWNOISE,HFE:300-600,FAILCHILD		1		
Q2403	943213500150S	NPN,TO-92,LOWNOISE,HFE:300-600,FAILCHILD		1		
Q2501	943211500150S	PNP,TO-92,LOWNOISE,HFE:300-600,FAILCHILD		1		
Q2502	943211500150S	PNP,TO-92,LOWNOISE,HFE:300-600,FAILCHILD		1		
Q2503	943213500150S	NPN,TO-92,LOWNOISE,HFE:300-600,FAILCHILD		1		
Q2601	943211500150S	PNP,TO-92,LOWNOISE,HFE:300-600,FAILCHILD		1		
Q2602	943211500150S	PNP,TO-92,LOWNOISE,HFE:300-600,FAILCHILD		1		
Q2603	943213500150S	NPN,TO-92,LOWNOISE,HFE:300-600,FAILCHILD		1		
Q2701	943211500150S	PNP,TO-92,LOWNOISE,HFE:300-600,FAILCHILD		1		
Q2702	943211500150S	PNP,TO-92,LOWNOISE,HFE:300-600,FAILCHILD		1		
Q2703	943213500150S	NPN,TO-92,LOWNOISE,HFE:300-600,FAILCHILD		1		
RESISTOR GROUP						
R2101	nsp	RES,CARBON(1/5W,100Kohm,J)		1		
R2102	nsp	RES,CARBON(1/5W,680ohm,J)		1		
R2103	nsp	RES,CARBON(1/5W,10Kohm,J)		1		
R2104	nsp	RES,CARBON(1/5W,18Kohm,J)		1		
R2105	nsp	RES,CARBON(1/5W,1.2Kohm,J)		1		
R2106	nsp	RES,M-OXIDEFILM(1W/1.2Kohm)		1		
R2107	nsp	RES,CARBON(1/5W,220ohm,J)		1		
R2108	nsp	RES,CARBON(1/5W,470Kohm,J)		1		
R2109	nsp	RES,CARBON(1/5W,33Kohm,J)		1		
R2110	nsp	RES,M-OXIDEFILM(1W/47ohm)		1		
R2201	nsp	RES,CARBON(1/5W,100Kohm,J)		1		
R2202	nsp	RES,CARBON(1/5W,680ohm,J)		1		
R2203	nsp	RES,CARBON(1/5W,10Kohm,J)		1		
R2204	nsp	RES,CARBON(1/5W,18Kohm,J)		1		
R2205	nsp	RES,CARBON(1/5W,1.2Kohm,J)		1		
R2206	nsp	RES,M-OXIDEFILM(1W/1.2Kohm)		1		
R2207	nsp	RES,CARBON(1/5W,220ohm,J)		1		
R2208	nsp	RES,CARBON(1/5W,470Kohm,J)		1		
R2209	nsp	RES,CARBON(1/5W,33Kohm,J)		1		
R2210	nsp	RES,M-OXIDEFILM(1W/47ohm)		1		
R2301	nsp	RES,CARBON(1/5W,100Kohm,J)		1		
R2302	nsp	RES,CARBON(1/5W,680ohm,J)		1		
R2303	nsp	RES,CARBON(1/5W,10Kohm,J)		1		
R2304	nsp	RES,CARBON(1/5W,18Kohm,J)		1		
R2305	nsp	RES,CARBON(1/5W,1.2Kohm,J)		1		
R2306	nsp	RES,M-OXIDEFILM(1W/1.2Kohm)		1		
R2307	nsp	RES,CARBON(1/5W,220ohm,J)		1		
R2308	nsp	RES,CARBON(1/5W,470Kohm,J)		1		
R2309	nsp	RES,CARBON(1/5W,33Kohm,J)		1		
R2310	nsp	RES,M-OXIDEFILM(1W/47ohm)		1		
R2401	nsp	RES,CARBON(1/5W,100Kohm,J)		1		
R2402	nsp	RES,CARBON(1/5W,680ohm,J)		1		
R2403	nsp	RES,CARBON(1/5W,10Kohm,J)		1		
R2404	nsp	RES,CARBON(1/5W,18Kohm,J)		1		
R2405	nsp	RES,CARBON(1/5W,1.2Kohm,J)		1		
R2406	nsp	RES,M-OXIDEFILM(1W/1.2Kohm)		1		
R2407	nsp	RES,CARBON(1/5W,220ohm,J)		1		
R2408	nsp	RES,CARBON(1/5W,470Kohm,J)		1		
R2409	nsp	RES,CARBON(1/5W,33Kohm,J)		1		
R2410	nsp	RES,M-OXIDEFILM(1W/47ohm)		1		
R2501	nsp	RES,CARBON(1/5W,100Kohm,J)		1		
R2502	nsp	RES,CARBON(1/5W,680ohm,J)		1		
R2503	nsp	RES,CARBON(1/5W,10Kohm,J)		1		
R2504	nsp	RES,CARBON(1/5W,18Kohm,J)		1		
R2505	nsp	RES,CARBON(1/5W,1.2Kohm,J)		1		
R2506	nsp	RES,M-OXIDEFILM(1W/1.2Kohm)		1		
R2507	nsp	RES,CARBON(1/5W,220ohm,J)		1		
R2508	nsp	RES,CARBON(1/5W,470Kohm,J)		1		
R2509	nsp	RES,CARBON(1/5W,33Kohm,J)		1		
R2510	nsp	RES,M-OXIDEFILM(1W/47ohm)		1		
R2601	nsp	RES,CARBON(1/5W,100Kohm,J)		1		
R2602	nsp	RES,CARBON(1/5W,680ohm,J)		1		
R2603	nsp	RES,CARBON(1/5W,10Kohm,J)		1		
R2604	nsp	RES,CARBON(1/5W,18Kohm,J)		1		
R2605	nsp	RES,CARBON(1/5W,1.2Kohm,J)		1		
R2606	nsp	RES,M-OXIDEFILM(1W/1.2Kohm)		1		
R2607	nsp	RES,CARBON(1/5W,220ohm,J)		1		
R2608	nsp	RES,CARBON(1/5W,470Kohm,J)		1		
R2609	nsp	RES,CARBON(1/5W,33Kohm,J)		1		
R2610	nsp	RES,M-OXIDEFILM(1W/47ohm)		1		
R2701	nsp	RES,CARBON(1/5W,100Kohm,J)		1		
R2702	nsp	RES,CARBON(1/5W,680ohm,J)		1		
R2703	nsp	RES,CARBON(1/5W,10Kohm,J)		1		
R2704	nsp	RES,CARBON(1/5W,18Kohm,J)		1		
R2705	nsp	RES,CARBON(1/5W,1.2Kohm,J)		1		
R2706	nsp	RES,M-OXIDEFILM(1W/1.2Kohm)		1		
R2707	nsp	RES,CARBON(1/5W,220ohm,J)		1		
R2708	nsp	RES,CARBON(1/5W,470Kohm,J)		1		
R2709	nsp	RES,CARBON(1/5W,33Kohm,J)		1		
R2710	nsp	RES,M-OXIDEFILM(1W/47ohm)		1		
CAPACITORS GROUP						
C2101	nsp	CAP,ELECT(50V/47uF)		1		
C2102	nsp	CAP,MYLAR(100V/470pF/J)		1		
C2103	nsp	CAP,CERAMIC(50V/82pF/J)		1		
C2104	nsp	CAP,MYLAR(50V/2200pF/J)		1		
C2105	nsp	CAP,ELECT(50V/220uF)		1		
C2106	nsp	CAP,CERAMIC(50V/33pF/J)		1		
C2201	nsp	CAP,ELECT(50V/47uF)		1		
C2202	nsp	CAP,MYLAR(100V/470pF/J)		1		
C2203	nsp	CAP,CERAMIC(50V/82pF/J)		1		
C2204	nsp	CAP,MYLAR(50V/2200pF/J)		1		
C2205	nsp	CAP,ELECT(50V/220uF)		1		

REF No.	Part No.	Part Name	Remarks	Q'ty	New	Ver
C2206	nsp	CAP,CERAMIC(50V/33pF/J)		CCCT1H330JC	1	
C2301	nsp	CAP,ELECT(50V/47uF)		CCEA1HH470T	1	
C2302	nsp	CAP,MYLAR(100V/470pF/J)		HCQI2A471JZT	1	
C2303	nsp	CAP,CERAMIC(50V/82pF/J)		CCCT1H820JC	1	
C2304	nsp	CAP,MYLAR(50V/2200pF/J)		HCQI1H222JZT	1	
C2305	nsp	CAP,ELECT(50V/220uF)		CCEA1HH221T	1	
C2306	nsp	CAP,CERAMIC(50V/33pF/J)		CCCT1H330JC	1	
C2401	nsp	CAP,ELECT(50V/47uF)		CCEA1HH470T	1	
C2402	nsp	CAP,MYLAR(100V/470pF/J)		HCQI2A471JZT	1	
C2403	nsp	CAP,CERAMIC(50V/82pF/J)		CCCT1H820JC	1	
C2404	nsp	CAP,MYLAR(50V/2200pF/J)		HCQI1H222JZT	1	
C2405	nsp	CAP,ELECT(50V/220uF)		CCEA1HH221T	1	
C2406	nsp	CAP,CERAMIC(50V/33pF/J)		CCCT1H330JC	1	
C2501	nsp	CAP,ELECT(50V/47uF)		CCEA1HH470T	1	
C2502	nsp	CAP,MYLAR(100V/470pF/J)		HCQI2A471JZT	1	
C2503	nsp	CAP,CERAMIC(50V/82pF/J)		CCCT1H820JC	1	
C2504	nsp	CAP,MYLAR(50V/2200pF/J)		HCQI1H222JZT	1	
C2505	nsp	CAP,ELECT(50V/220uF)		CCEA1HH221T	1	
C2506	nsp	CAP,CERAMIC(50V/33pF/J)		CCCT1H330JC	1	
C2601	nsp	CAP,ELECT(50V/47uF)		CCEA1HH470T	1	
C2602	nsp	CAP,MYLAR(100V/470pF/J)		HCQI2A471JZT	1	
C2603	nsp	CAP,CERAMIC(50V/82pF/J)		CCCT1H820JC	1	
C2604	nsp	CAP,MYLAR(50V/2200pF/J)		HCQI1H222JZT	1	
C2605	nsp	CAP,ELECT(50V/220uF)		CCEA1HH221T	1	
C2606	nsp	CAP,CERAMIC(50V/33pF/J)		CCCT1H330JC	1	
C2701	nsp	CAP,ELECT(50V/47uF)		CCEA1HH470T	1	
C2702	nsp	CAP,MYLAR(100V/470pF/J)		HCQI2A471JZT	1	
C2703	nsp	CAP,CERAMIC(50V/82pF/J)		CCCT1H820JC	1	
C2704	nsp	CAP,MYLAR(50V/2200pF/J)		HCQI1H222JZT	1	
C2705	nsp	CAP,ELECT(50V/220uF)		CCEA1HH221T	1	
C2706	nsp	CAP,CERAMIC(50V/33pF/J)		CCCT1H330JC	1	
C2800	nsp	CAP,ELECT(50V/10uF)		CCEA1HH100T	1	
OTHER PARTS GROUP						
BK201	nsp	BRACKET_PCB		CMD1A569-V1	1	
BK202	nsp	BRACKET_PCB		CMD1A387-V1	1	
BK203	nsp	BRACKET_PCB		CMD1A569-V1	1	
BK204	nsp	BRACKET_PCB		CMD1A387-V1	1	
BN51A	nsp	WIREASS'YLocking(YH)(3P,2MM,50MM,#24)		CWB4C003050CC	7	
CN201	nsp	PINHEADER(15P,1.25mm,STRAIGHT,B-TO-B)		CJP15GI281Z	1	
CN51A	nsp	PIN SOCKET(07P,1.25mm,ANGLE,B-TO-B)		CJP07HJ282Z	1	
CN52A	nsp	PIN SOCKET(07P,1.25mm,ANGLE,B-TO-B)		CJP07HJ282Z	1	
CN53A	nsp	PIN SOCKET(07P,1.25mm,ANGLE,B-TO-B)		CJP07HJ282Z	1	
CN54A	nsp	PIN SOCKET(07P,1.25mm,ANGLE,B-TO-B)		CJP07HJ282Z	1	
CN55A	nsp	PIN SOCKET(07P,1.25mm,ANGLE,B-TO-B)		CJP07HJ282Z	1	
CN56A	nsp	PIN SOCKET(07P,1.25mm,ANGLE,B-TO-B)		CJP07HJ282Z	1	
CN57A	nsp	PIN SOCKET(07P,1.25mm,ANGLE,B-TO-B)		CJP07HJ282Z	1	

MAIN PCB ASS'Y

※Parts indicated by "nsp" on this table cannot be supplied. Part indicated by "*" mark is not illustrated in the exploded view
 ※The parts listed below are only for maintenance. Therefore they might differ from the parts used in the unit in appearances or dimensions
 NOTE: The symbols in the column Remarks indicate the following destinations.
 E3 : U.S.A. & Canada model E2 : Europe model E1C : China model E1 : Asia model JP : Japan model
 BK : Black model SP : Premium Silver model

REF No.	Part No.	Part Name	Remarks	Q'ty	New	Ver
SEMICONDUCTORS GROUP						
D5106	00D9430182609	DIODE, SWITCHING		CVD1SS133MT	1	
D5206	00D9430182609	DIODE, SWITCHING		CVD1SS133MT	1	
D5306	00D9430182609	DIODE, SWITCHING		CVD1SS133MT	1	
D5406	00D9430182609	DIODE, SWITCHING		CVD1SS133MT	1	
D5506	00D9430182609	DIODE, SWITCHING		CVD1SS133MT	1	
D5606	00D9430182609	DIODE, SWITCHING		CVD1SS133MT	1	
D5706	00D9430182609	DIODE, SWITCHING		CVD1SS133MT	1	
D5801	00D9430182609	DIODE, SWITCHING		CVD1SS133MT	1	
D5802	00D9430182609	DIODE, SWITCHING		CVD1SS133MT	1	
D5803	00D9430182609	DIODE, SWITCHING		CVD1SS133MT	1	
D5804	00D9430182609	DIODE, SWITCHING		CVD1SS133MT	1	
D5805	00D9430182609	DIODE, SWITCHING		CVD1SS133MT	1	
D5806	00D9430182609	DIODE, SWITCHING		CVD1SS133MT	1	
D5807	9432025011150S	DIODE, ZENER, 1/2W, 3.6V		CVDZJ3V6BL	1	*
D5808	00D9430182609	DIODE, SWITCHING		CVD1SS133MT	1	
D5809	00D9430182609	DIODE, SWITCHING		CVD1SS133MT	1	
D5810	00D9430182609	DIODE, SWITCHING		CVD1SS133MT	1	
D5811	00D9430182609	DIODE, SWITCHING		CVD1SS133MT	1	
D5812	00D9430182609	DIODE, SWITCHING		CVD1SS133MT	1	
D5813	00D9430182609	DIODE, SWITCHING		CVD1SS133MT	1	
D5814	00D9430182609	DIODE, SWITCHING		CVD1SS133MT	1	
D5815	9432025011150S	DIODE, ZENER, 1/2W, 3.6V		CVDZJ3V6BL	1	*
D5816	00D9430182609	DIODE, SWITCHING		CVD1SS133MT	1	
D5817	943202501110S	DIODE, ZENER, 1/2W, 6.8V		CVDZJ6V8BL	1	*
D5818	00D9430182609	DIODE, SWITCHING		CVD1SS133MT	1	
D5819	943209500040S	DIODE, BRIDGE(600V/10A)		CVD10SB60	1	
IC501	943232100380S	I.C, DUALOPAMP(SOP-8P)		CVINJM8080G	1	
Q5105	943216500510S	TR, POWER(MICA43TYPE)		CVT2SD2390P43M	1	
Q5106	963215500500D	TR, POWER(MICA43TYPE)		CVT2SB1560P43M	1	
Q5107	943212500330S	TR, INA6002AC1, PNP, SC-59, ISAHAYA		CVTINA6002AC1	1	
Q5108	943214500370S	TR, INA6002AC1, NPN, SC-59, ISAHAYA		CVTINC6002AC1	1	
Q5205	943216500510S	TR, POWER(MICA43TYPE)		CVT2SD2390P43M	1	
Q5206	963215500500D	TR, POWER(MICA43TYPE)		CVT2SB1560P43M	1	
Q5207	943212500330S	TR, INA6002AC1, PNP, SC-59, ISAHAYA		CVTINA6002AC1	1	
Q5208	943214500370S	TR, INA6002AC1, NPN, SC-59, ISAHAYA		CVTINC6002AC1	1	
Q5305	943216500510S	TR, POWER(MICA43TYPE)		CVT2SD2390P43M	1	
Q5306	963215500500D	TR, POWER(MICA43TYPE)		CVT2SB1560P43M	1	
Q5307	943212500330S	TR, INA6002AC1, PNP, SC-59, ISAHAYA		CVTINA6002AC1	1	
Q5308	943214500370S	TR, INA6002AC1, NPN, SC-59, ISAHAYA		CVTINC6002AC1	1	
Q5405	943216500510S	TR, POWER(MICA43TYPE)		CVT2SD2390P43M	1	
Q5406	963215500500D	TR, POWER(MICA43TYPE)		CVT2SB1560P43M	1	
Q5407	943212500330S	TR, INA6002AC1, PNP, SC-59, ISAHAYA		CVTINA6002AC1	1	
Q5408	943214500370S	TR, INA6002AC1, NPN, SC-59, ISAHAYA		CVTINC6002AC1	1	
Q5505	943216500510S	TR, POWER(MICA43TYPE)		CVT2SD2390P43M	1	
Q5506	90M-HT200440R	T, R, POWER		HVT2SB1560	1	
Q5507	943212500330S	TR, INA6002AC1, PNP, SC-59, ISAHAYA		CVTINA6002AC1	1	
Q5508	943214500370S	TR, INA6002AC1, NPN, SC-59, ISAHAYA		CVTINC6002AC1	1	
Q5605	90M-HT400490R	T, R, POWER		HVT2SD2390	1	
Q5606	963215500500D	TR, POWER(MICA43TYPE)		CVT2SB1560P43M	1	
Q5607	943212500330S	TR, INA6002AC1, PNP, SC-59, ISAHAYA		CVTINA6002AC1	1	
Q5608	943214500370S	TR, INA6002AC1, NPN, SC-59, ISAHAYA		CVTINC6002AC1	1	
Q5705	943216500510S	TR, POWER(MICA43TYPE)		CVT2SD2390P43M	1	
Q5706	963215500500D	TR, POWER(MICA43TYPE)		CVT2SB1560P43M	1	
Q5707	943212500330S	TR, INA6002AC1, PNP, SC-59, ISAHAYA		CVTINA6002AC1	1	
Q5708	943214500370S	TR, INA6002AC1, NPN, SC-59, ISAHAYA		CVTINC6002AC1	1	
Q5801	943213500160S	T, R, RT1N237C(2.2K-47K)		CVTRT1N237C	1	
Q5802	943213500160S	T, R, RT1N237C(2.2K-47K)		CVTRT1N237C	1	
Q5803	943213500160S	T, R, RT1N237C(2.2K-47K)		CVTRT1N237C	1	
Q5804	943213500160S	T, R, RT1N237C(2.2K-47K)		CVTRT1N237C	1	
Q5805	943213500160S	T, R, RT1N237C(2.2K-47K)		CVTRT1N237C	1	
Q5806	943213500160S	T, R, RT1N237C(2.2K-47K)		CVTRT1N237C	1	
Q5807	943211500150S	PNP, TO-92, LOWNOISE, HFE:300-600, FAILCHILD		CVTKSA992FTA	1	
Q5808	943214500020S	T, R, 2SC3052		CVT2SC3052	1	
Q5809	963212500030S	T, R, ISA1530AC1		CVTISA1530AC1	1	
Q5810	943214500020S	T, R, 2SC3052		CVT2SC3052	1	
Q5811	943214500020S	T, R, 2SC3052		CVT2SC3052	1	
Q5812	963212500030S	T, R, ISA1530AC1		CVTISA1530AC1	1	
Q5813	943214500020S	T, R, 2SC3052		CVT2SC3052	1	
Q5814	943212500330S	TR, INA6002AC1, PNP, SC-59, ISAHAYA		CVTINA6002AC1	1	
RESISTOR GROUP						
R5113	nsp	RES, CARBON(1/5W, 2.7Kohm, J)		CRD20TJ272T	1	
R5114	nsp	RES, CARBON(1/5W, 560ohm, J)		CRD20TJ561T	1	
R5115	nsp	RES, M-OXIDEFILM(1W/5.6Kohm)		CRG1SANJ562RT	1	
R5116	nsp	RES, M-OXIDEFILM(1W/5.6Kohm)		CRG1SANJ562RT	1	
R5117	nsp	RES, M-OXIDEFILM(1W/4.7ohm)		CRG1SANJ47RT	1	
R5118	nsp	RES, M-OXIDEFILM(1W/4.7ohm)		CRG1SANJ47RT	1	
R5119	943124500050S	RES, M-OXIDEFILM(2W/0.47ohm)		CRG2SANJ47RT	1	
R5120	943124500050S	RES, M-OXIDEFILM(2W/0.47ohm)		CRG2SANJ47RT	1	
R5121	943124500050S	RES, M-OXIDEFILM(2W/0.47ohm)		CRG2SANJ47RT	1	
R5122	943124500050S	RES, M-OXIDEFILM(2W/0.47ohm)		CRG2SANJ47RT	1	
R5123	nsp	RES, CARBON(1/5W, 820Kohm, J)		CRD20TJ824T	1	
R5124	nsp	RES, CARBON(1/5W, 150Kohm, J)		CRD20TJ154T	1	
R5125	nsp	RES, CARBON(1/5W, 10Kohm, J)		CRD20TJ103T	1	
R5126	943252101070S	PTCTHEMISTORS, CHIP(115°C)		CRTDHPTF1608471P115T	1	*
R5127	nsp	RES, CARBON(1/5W, 5.6Kohm, J)		CRD20TJ562T	1	
R5129	nsp	RES, CARBON(1/5W, 15Kohm, J)		CRD20TJ153T	1	
R5130	nsp	RES, CARBON(1/5W, 22Kohm, J)		CRD20TJ223T	1	
R5131	nsp	RES, CARBON(1/5W, 22Kohm, J)		CRD20TJ223T	1	
R5132	nsp	RES, M-OXIDEFILM(1W/10ohm)		CRG1SANJ100RT	1	
R5133	nsp	RES, M-OXIDEFILM(2W/10ohm)		CRG2SANJ100RT	1	
R5213	nsp	RES, CARBON(1/5W, 2.7Kohm, J)		CRD20TJ272T	1	
R5214	nsp	RES, CARBON(1/5W, 560ohm, J)		CRD20TJ561T	1	
R5215	nsp	RES, M-OXIDEFILM(1W/5.6Kohm)		CRG1SANJ562RT	1	
R5216	nsp	RES, M-OXIDEFILM(1W/5.6Kohm)		CRG1SANJ562RT	1	
R5217	nsp	RES, M-OXIDEFILM(1W/4.7ohm)		CRG1SANJ47RT	1	
R5218	nsp	RES, M-OXIDEFILM(1W/4.7ohm)		CRG1SANJ47RT	1	
R5219	943124500050S	RES, M-OXIDEFILM(2W/0.47ohm)		CRG2SANJ47RT	1	
R5220	943124500050S	RES, M-OXIDEFILM(2W/0.47ohm)		CRG2SANJ47RT	1	
R5221	943124500050S	RES, M-OXIDEFILM(2W/0.47ohm)		CRG2SANJ47RT	1	
R5222	943124500050S	RES, M-OXIDEFILM(2W/0.47ohm)		CRG2SANJ47RT	1	
R5223	nsp	RES, CARBON(1/5W, 820Kohm, J)		CRD20TJ824T	1	
R5224	nsp	RES, CARBON(1/5W, 150Kohm, J)		CRD20TJ154T	1	
R5225	nsp	RES, CARBON(1/5W, 10Kohm, J)		CRD20TJ103T	1	
R5226	943252101070S	PTCTHEMISTORS, CHIP(115°C)		CRTDHPTF1608471P115T	1	*
R5227	nsp	RES, CARBON(1/5W, 5.6Kohm, J)		CRD20TJ562T	1	
R5229	nsp	RES, CARBON(1/5W, 15Kohm, J)		CRD20TJ153T	1	
R5230	nsp	RES, CARBON(1/5W, 22Kohm, J)		CRD20TJ223T	1	
R5231	nsp	RES, CARBON(1/5W, 22Kohm, J)		CRD20TJ223T	1	
R5232	nsp	RES, M-OXIDEFILM(1W/10ohm)		CRG1SANJ100RT	1	

REF No.	Part No.	Part Name	Remarks	Q'ty	New	Ver
R5817	nsp	RES.CARBON(1/5W,470Kohm,J)	CRD20TJ474T	1		
R5818	nsp	RES.CARBON(1/5W,470Kohm,J)	CRD20TJ474T	1		
R5819	nsp	RES.M-OXIDEFILM(1W/100ohm)	CRG1SANJ101RT	1		
R5820	nsp	RES.M-OXIDEFILM(1W/33ohm)	CRG1SANJ330RT	1		
R5821	nsp	RES.M-OXIDEFILM(1W/2.2Kohm)	CRG1SANJ222RT	1		
R5823	nsp	RES.M-OXIDEFILM(1W/2.2Kohm)	CRG1SANJ222RT	1		
R5824	nsp	RES.M-OXIDEFILM(1W/2.2Kohm)	CRG1SANJ222RT	1		
R5827	943129501040S	RES.CEMENT(5W,0.01OHM,5%SMALLSIZE)	CRF5EJR01HS	1		
R5830	nsp	RES.CHIP(1608/5%/100ohm)	CRJ10DJ101T	1		
R5831	nsp	RES.CHIP(1608/5%/10Kohm)	CRJ10DJ103T	1		
R5832	nsp	RES.CHIP(1608/5%/1Kohm)	CRJ10DJ102T	1		
R5833	nsp	RES.CHIP(1608/5%/22Kohm)	CRJ10DJ223T	1		
R5834	nsp	RES.CHIP(1608/5%/3.3Kohm)	CRJ10DJ332T	1		
R5835	nsp	RES.CHIP(1608/5%/330Kohm)	CRJ10DJ334T	1		
R5836	nsp	RES.CHIP(1608/5%/33Kohm)	CRJ10DJ333T	1		
R5837	nsp	RES.CHIP(1608/5%/10Kohm)	CRJ10DJ103T	1		
R5838	nsp	RES.CHIP(1608/5%/22Kohm)	CRJ10DJ223T	1		
R5839	nsp	RES.CHIP(1608/5%/10Kohm)	CRJ10DJ103T	1		
R5840	nsp	RES.CHIP(1608/5%/10Kohm)	CRJ10DJ103T	1		
R5841	nsp	RES.CARBON(1/5W,10Kohm,J)	CRD20TJ103T	1		
R5842	nsp	RES.CARBON(1/5W,22Kohm,J)	CRD20TJ223T	1		
R5843	nsp	RES.CARBON(1/5W,33Kohm,J)	CRD20TJ333T	1		
R5844	nsp	RES.CARBON(1/5W,33Kohm,J)	CRD20TJ333T	1		
R5845	nsp	RES.CARBON(1/5W,33Kohm,J)	CRD20TJ333T	1		
R5846	nsp	RES.CARBON(1/5W,2.2Kohm,J)	CRD20TJ222T	1		
CAPACITORS GROUP						
C5107	nsp	CAP.ELECT(16V/220uF)	CCEA1CH221T	1		
C5108	nsp	CAP.ELECT(63V/220uF)	CCEA1JH221E	1		
C5109	nsp	CAP.MYLAR(50V/0.1uF/J)	HCQ1H104JZT	1		
C5110	nsp	CAP.MYLAR(50V/0.047uF/J)	HCQ1H473JZT	1		
C5111	nsp	CAP.MYLAR(50V/0.018pF/J)	HCQ1H183JZT	1		
C5113	nsp	CAP.MYLAR(50V/1500pF/J)	HCQ1H152JZT	1		
C5120	nsp	CAP.MYLAR(50V/0.047uF/J)	HCQ1H473JZT	1		
C5207	nsp	CAP.ELECT(16V/220uF)	CCEA1CH221T	1		
C5208	nsp	CAP.ELECT(63V/220uF)	CCEA1JH221E	1		
C5209	nsp	CAP.MYLAR(50V/0.1uF/J)	HCQ1H104JZT	1		
C5211	nsp	CAP.MYLAR(50V/0.018pF/J)	HCQ1H183JZT	1		
C5213	nsp	CAP.MYLAR(50V/1500pF/J)	HCQ1H152JZT	1		
C5307	nsp	CAP.ELECT(16V/220uF)	CCEA1CH221T	1		
C5308	nsp	CAP.ELECT(63V/220uF)	CCEA1JH221E	1		
C5309	nsp	CAP.MYLAR(50V/0.1uF/J)	HCQ1H104JZT	1		
C5310	nsp	CAP.MYLAR(50V/0.047uF/J)	HCQ1H473JZT	1		
C5311	nsp	CAP.MYLAR(50V/0.018pF/J)	HCQ1H183JZT	1		
C5313	nsp	CAP.MYLAR(50V/1500pF/J)	HCQ1H152JZT	1		
C5407	nsp	CAP.ELECT(16V/220uF)	CCEA1CH221T	1		
C5408	nsp	CAP.ELECT(63V/220uF)	CCEA1JH221E	1		
C5409	nsp	CAP.MYLAR(50V/0.1uF/J)	HCQ1H104JZT	1		
C5410	nsp	CAP.MYLAR(50V/0.047uF/J)	HCQ1H473JZT	1		
C5411	nsp	CAP.MYLAR(50V/0.018pF/J)	HCQ1H183JZT	1		
C5413	nsp	CAP.MYLAR(50V/1500pF/J)	HCQ1H152JZT	1		
C5507	nsp	CAP.ELECT(16V/220uF)	CCEA1CH221T	1		
C5508	nsp	CAP.ELECT(63V/220uF)	CCEA1JH221E	1		
C5509	nsp	CAP.MYLAR(50V/0.1uF/J)	HCQ1H104JZT	1		
C5510	nsp	CAP.MYLAR(50V/0.047uF/J)	HCQ1H473JZT	1		
C5511	nsp	CAP.MYLAR(50V/0.018pF/J)	HCQ1H183JZT	1		
C5513	nsp	CAP.MYLAR(50V/1500pF/J)	HCQ1H152JZT	1		
C5607	nsp	CAP.ELECT(16V/220uF)	CCEA1CH221T	1		
C5608	nsp	CAP.ELECT(63V/220uF)	CCEA1JH221E	1		
C5609	nsp	CAP.MYLAR(50V/0.1uF/J)	HCQ1H104JZT	1		
C5610	nsp	CAP.MYLAR(50V/0.047uF/J)	HCQ1H473JZT	1		
C5611	nsp	CAP.MYLAR(50V/0.018pF/J)	HCQ1H183JZT	1		
C5613	nsp	CAP.MYLAR(50V/1500pF/J)	HCQ1H152JZT	1		
C5707	nsp	CAP.ELECT(16V/220uF)	CCEA1CH221T	1		
C5708	nsp	CAP.ELECT(63V/220uF)	CCEA1JH221E	1		
C5709	nsp	CAP.MYLAR(50V/0.1uF/J)	HCQ1H104JZT	1		
C5710	nsp	CAP.MYLAR(50V/0.047uF/J)	HCQ1H473JZT	1		
C5711	nsp	CAP.MYLAR(50V/0.018pF/J)	HCQ1H183JZT	1		
C5713	nsp	CAP.MYLAR(50V/1500pF/J)	HCQ1H152JZT	1		
C5801	nsp	CAP.MYLAR(50V/0.1uF/J)	HCQ1H104JZT	1		
C5802	nsp	CAP.ELECT(6.3V/470uF)	CCEA0JH471T	1		
C5803	nsp	CAP.MYLAR(50V/0.1uF/J)	HCQ1H104JZT	1		
C5804	nsp	CAP.ELECT(10V/100uF)	CCEA1AH101T	1		
C5805	nsp	CAP.ELECT(16V/47uF)	CCEA1CH470T	1		
C5806	nsp	CAP.CHIP(1608.50V/0.1uF,X7R)_SAMSUNG	CCUS1H104KCS	1		
C5807	nsp	CAP.ELECT(50V/10uF)	CCEA1HH100T	1		
C5808	943134010480S	CAP.ELECT(100V/100uF)	CCEA2AH101E	1		
C5809	nsp	CAP.ELECT(50V/10uF)	CCEA1HH100T	1		
C5810	943134503680S	CAP.ELECT(69V/10000uF),85°C,35x45	CCET69VLS103N	1		
C5811	943134503680S	CAP.ELECT(69V/10000uF),85°C,35x45	CCET69VLS103N	1		
C5812	90M-OF100490R	CAP.METALPEFILM(250V/0.1uF)	KCME2E104JP04T	1		
C5813	90M-OF100490R	CAP.METALPEFILM(250V/0.1uF)	KCME2E104JP04T	1		
C5816	nsp	CAP.MYLAR(50V/0.1uF/J)	HCQ1H104JZT	1		
C5817	nsp	CAP.CHIP(1608.50V/0.1uF,X7R)_SAMSUNG	CCUS1H104KCS	1		
C5818	nsp	CAP.CHIP(1608.50V/0.1uF,X7R)_SAMSUNG	CCUS1H104KCS	1		
C5819	nsp	CAP.ELECT(16V/100uF)	CCEA1CH101T	1		
C5820	nsp	CAP.ELECT(100V/1uF),85°CBlack	CCEA2AH1R0T	1		
C5821	nsp	CAP.CHIP(1608.50V/100pF,COG)_SAMSUNG	CCUS1H101JAS	1		
C5823	nsp	CAP.CHIP(1608.50V/10pF,COG)_SAMSUNG	CCUS1H100JAS	1		
C5825	nsp	CAP.ELECT(100V/1uF),85°CBlack	CCEA2AH1R0T	1		
C5826	nsp	CAP.ELECT(100V/1uF),85°CBlack	CCEA2AH1R0T	1		
C5827	nsp	CAP.MYLAR(50V/0.01uF/J)	HCQ1H103JZT	1		
OTHER PARTS GROUP						
BK505	nsp	BRACKET,PCB	CMD1A569-V1	1		
BN501	nsp	WIREASS'YLocking(YH)(9P,2MM,150MM,#26)	CWB1B009150HC	1		
BN502	nsp	WIREASS'YLocking(YH)(8P,2MM,150MM,#26)	CWB1B008150HC	1		
BN503	nsp	WIREASS'YLocking(YH)(3P,2MM,200MM,#26)	CWB4B003200HC	1		
CN502	nsp	WAFER,7P(DIP,3.96PITCH)	CJP07GA90ZY	1		
CN508	nsp	PINHEADER(09P,1.25mm,STRAIGHT,B-TO-B)	CJP09GI281Z	1		
CN510	nsp	WAFER/STRAIGHT/2.5mm/2P	CJP02GA01ZY	1		
CN51B	nsp	PINHEADER(07P,1.25mm,STRAIGHT,B-TO-B)	CJP07GI281Z	1		
CN520	nsp	WAFER/STRAIGHT/2.5mm/2P	CJP02GA01ZY	1		
CN52B	nsp	PINHEADER(07P,1.25mm,STRAIGHT,B-TO-B)	CJP07GI281Z	1		
CN530	nsp	WAFER/STRAIGHT/2.5mm/2P	CJP02GA01ZY	1		
CN53B	nsp	PINHEADER(07P,1.25mm,STRAIGHT,B-TO-B)	CJP07GI281Z	1		
CN540	nsp	WAFER/STRAIGHT/2.5mm/2P	CJP02GA01ZY	1		
CN54B	nsp	PINHEADER(07P,1.25mm,STRAIGHT,B-TO-B)	CJP07GI281Z	1		
CN550	nsp	WAFER/STRAIGHT/2.5mm/2P	CJP02GA01ZY	1		
CN55B	nsp	PINHEADER(07P,1.25mm,STRAIGHT,B-TO-B)	CJP07GI281Z	1		
CN560	nsp	WAFER/STRAIGHT/2.5mm/2P	CJP02GA01ZY	1		
CN56B	nsp	PINHEADER(07P,1.25mm,STRAIGHT,B-TO-B)	CJP07GI281Z	1		
CN570	nsp	WAFER/STRAIGHT/2.5mm/2P	CJP02GA01ZY	1		
CN57B	nsp	PINHEADER(07P,1.25mm,STRAIGHT,B-TO-B)	CJP07GI281Z	1		
ET502	nsp	PLATE.EARTH(TRONICELECTRONICS)	CJT1A026	1		
JK501	943643102420S	2P.SCREWSPK(R/B)	CJJ5N023Z	1		
JK502	943643102420S	2P.SCREWSPK(R/B)	CJJ5N023Z	1		
JK503	943643102420S	2P.SCREWSPK(R/B)	CJJ5N023Z	1		
JK504	943643102420S	2P.SCREWSPK(R/B)	CJJ5N023Z	1		

REF No.	Part No.	Part Name	Remarks	Q'ty	New	Ver
JK505	943643102420S	2P.SCREWSPK(R/B)		CJJ5N023Z	1	
JK506	943643102420S	2P.SCREWSPK(R/B)		CJJ5N023Z	1	
JK507	943643102420S	2P.SCREWSPK(R/B)		CJJ5N023Z	1	
L5101	943115100310S	COIL,SPEAKER(0.5UH)		CLEY0R5KAD	1	
L5201	943115100310S	COIL,SPEAKER(0.5UH)		CLEY0R5KAD	1	
L5301	943115100310S	COIL,SPEAKER(0.5UH)		CLEY0R5KAD	1	
L5401	943115100310S	COIL,SPEAKER(0.5UH)		CLEY0R5KAD	1	
L5501	943115100310S	COIL,SPEAKER(0.5UH)		CLEY0R5KAD	1	
L5601	943115100310S	COIL,SPEAKER(0.5UH)		CLEY0R5KAD	1	
L5701	943115100310S	COIL,SPEAKER(0.5UH)		CLEY0R5KAD	1	
RY581	943682000810S	RELAY,BC3-12H,DC12V,2C2P		CSL4A016ZU	1	
RY582	943682100270S	RELAY,981-2A-12DS,DC12V,2C1P		CSL3A022ZU	1	
RY583	943682100270S	RELAY,981-2A-12DS,DC12V,2C1P		CSL3A022ZU	1	
RY584	943682100270S	RELAY,981-2A-12DS,DC12V,2C1P		CSL3A022ZU	1	
RY585	943682100270S	RELAY,981-2A-12DS,DC12V,2C1P		CSL3A022ZU	1	
RY586	943682100520S	RELAY,942H-2C-12DS,DC12V,2C2P		CSL4A022ZU	1	
TU500	943183100510S	TUNER,FM(SCREW:FTYPE),AM,SI4730-D60	S720, E3	CNVYST990-A9U1	1	
TU500	943183100640S	TUNER, RDS, FM(PAL TYPE), AM, SI4731-D60	E2	CNVYST990-D8E2	1	
TU500	943183100500S	TUNER, FM(PAL TYPE), AM, SI4730-D60	E1C, JP	CNVYST990-A2J1	1	
VR510	943679100020S	RES.SEMIFIXED(1K,BCURVE)		CVN12A102B03T	1	
VR520	943679100020S	RES.SEMIFIXED(1K,BCURVE)		CVN12A102B03T	1	
VR530	943679100020S	RES.SEMIFIXED(1K,BCURVE)		CVN12A102B03T	1	
VR540	943679100020S	RES.SEMIFIXED(1K,BCURVE)		CVN12A102B03T	1	
VR550	943679100020S	RES.SEMIFIXED(1K,BCURVE)		CVN12A102B03T	1	
VR560	943679100020S	RES.SEMIFIXED(1K,BCURVE)		CVN12A102B03T	1	
VR570	943679100020S	RES.SEMIFIXED(1K,BCURVE)		CVN12A102B03T	1	
@	nsp	BRACKET,H/SPCB		CMD1A802	1	
@	nsp	COMPOUND,SILICONE		K8AYG6260	5.4	
@	nsp	BRACKET,H/S		VMD1A812	1	

POWER PCB ASS'Y

※Parts indicated by "nsp" on this table cannot be supplied. Part indicated by "@" mark is not illustrated in the exploded view.

※The parts listed below are only for maintenance. Therefore they might differ from the parts used in the unit in appearances or dimensions.

NOTE:The symbols in the column Remarks indicate the following destinations.

E3 : U.S.A. & Canada model E2 : Europe model E1C : China model E1 : Asia model JP : Japan model

BK : Black model SP : Premium Silver model

REF No.	Part No.	Part Name	Remarks	Q'ty	New	Ver
SEMICONDUCTORS GROUP						
D3001	943203500730S	DIODE,RECTIFIER,AXIAL				
D3002	943203500730S	DIODE,RECTIFIER,AXIAL				
D3003	943203500730S	DIODE,RECTIFIER,AXIAL				
D3004	943203500730S	DIODE,RECTIFIER,AXIAL				
D3103	00D9430182609	DIODE,SWITCHING				
D3104	00D9430182609	DIODE,SWITCHING				
D3200	201310001503S	DIODE,ULTRA-HIGH SPEED	E3			
D6001	943203500730S	DIODE,RECTIFIER,AXIAL				
D6002	943203500730S	DIODE,RECTIFIER,AXIAL				
D6003	943203500730S	DIODE,RECTIFIER,AXIAL				
D6004	943203500730S	DIODE,RECTIFIER,AXIAL				
D6005	943203500730S	DIODE,RECTIFIER,AXIAL				
D6006	943203500730S	DIODE,RECTIFIER,AXIAL				
D6007	943203500730S	DIODE,RECTIFIER,AXIAL				
D6008	943203500730S	DIODE,RECTIFIER,AXIAL				
D6009	00D9430182609	DIODE,SWITCHING				
D6012	943203500730S	DIODE,RECTIFIER,AXIAL				
D6013	943204500310S	DIODE,SchottkyBattier(TO220FN)				
IC301	943232100370S	I.C.REGULATOR(+12V,TO220)				
IC302	00D9430183909	I.C.REGULATOR				
IC305	943231010390S	I.C.REGULATOR(+5V,TO220IS)				
IC601	943231102160S	I.C.OFF-LINEPOWERSWITCH				
! IC602	963239010480S	I.C.PHOTOCOUPLER				
IC603	212050010508S	I.C.SHUNTREGULATOR(TO-92)				
IC604	943239100730S	I.C.SYSTEMRESET(4.8V,SOT-25A)				
Q3001	943215500020S	T.R.RT1P141C(10K-10K)	E3			
Q3002	943214500020S	T.R.2SC3052	E3			
Q6002	943229500110S	F.E.T,INK0010AC1(N-CH,SC-59,MOSFET,ISAHAYA)				
Q6003	943214500020S	T.R.2SC3052				
ZD601	943202501140S	DIODE,ZENER,1/2W,12V				
ZD608	943202501120S	DIODE,ZENER,1/2W,39V	S720, E3, JP			
ZD609	943202501120S	DIODE,ZENER,1/2W,39V	S720, E3, JP			
ZD610	943202501120S	DIODE,ZENER,1/2W,39V	S720, E3, JP			
ZD611	943202501170S	DIODE,ZENER,1/2W,22V				
ZD612	943202501170S	DIODE,ZENER,1/2W,22V				
ZD613	943202501170S	DIODE,ZENER,1/2W,22V				
ZD614	943202501170S	DIODE,ZENER,1/2W,22V				
ZD615	943202501170S	DIODE,ZENER,1/2W,22V				
ZD616	943202501170S	DIODE,ZENER,1/2W,22V				
ZD617	943202501170S	DIODE,ZENER,1/2W,22V				
ZD618	943202501160S	DIODE,ZENER,1/2W,27V				
ZD619	943202501110S	DIODE,ZENER,1/2W,6.8V				
ZD620	943202501120S	DIODE,ZENER,1/2W,39V				
ZD621	943202501200S	DIODE,ZENER,1/2W,7.5V	S720, E3			
ZD621	943202501190S	DIODE,ZENER,1/2W,5.6V	K			
ZD621	943202501180S	DIODE,ZENER,1/2W,16V	E2, E1C			
RESISTOR GROUP						
R3001	nsp	RES,CHIP(1608/5%/1Kohm)	E3			
R3002	nsp	RES,CHIP(1608/5%/3.3Kohm)	E3			
R3003	nsp	RES,CHIP(1608/5%/2.2Kohm)	E3			
R3004	nsp	RES,CHIP(1608/5%/100Kohm)	E3			
R6004	nsp	RES,CARBON(1/5W,330Kohm,J)				
R6006	nsp	RES,CHIP(1608/5%/1Mohm)				
R6008	nsp	RES,CARBON(1/5W,2.2Mohm,J)	S720, E3, JP			
R6009	nsp	RES,CARBON(1/5W,2.2Mohm,J)	S720, E3, JP			
R6010	nsp	RES,CARBON(1/5W,1Mohm,J)	S720, E3, JP			
R6011	nsp	RES,CHIP(1608/5%/10ohm)				
R6012	nsp	RES,CHIP(1608/5%/270Kohm)	S720, E3, JP			
R6012	nsp	RES,CHIP(1608/5%/56Kohm)	E2, E1C			
R6013	nsp	RES,CHIP(1608/5%/22Kohm)				
R6014	nsp	RES,CHIP(1608/5%/1Kohm)	S720, E3, JP			
R6014	nsp	RES,CHIP(1608/5%/3Kohm)	E2, E1C			
R6015	nsp	RES,CARBON(1/5W,6.8ohm,J)				
R6016	nsp	RES,CARBON(1/5W,56ohm,J)				
R6017	nsp	RES,CARBON(1/5W,3.3Kohm,J)				
R6018	nsp	RES,CARBON(1/5W,5.6Kohm,J)				
R6019	nsp	RES,CHIP(1608/1%/22Kohm)				
R6022	nsp	RES,CHIP(1608/1%/6.8Kohm)				
R6024	nsp	RES,CHIP(1608/5%/10Kohm)				
R6025	nsp	RES,CHIP(1608/5%/4.7Kohm)				
R6027	nsp	RES,CHIP(2012/5%/8.2Mohm)				
R6028	nsp	RES,CHIP(2012/5%/8.2Mohm)				
R6029	nsp	RES,CHIP(2012/5%/8.2Mohm)				
R6030	nsp	RES,CHIP(2012/5%/8.2Mohm)				
R6031	nsp	RES,CHIP(2012/5%/1Mohm)				
R6032	nsp	RES,CHIP(2012/5%/1Mohm)				
R6033	nsp	RES,CHIP(2012/5%/1Mohm)				
CAPACITORS GROUP						
C3005	nsp	CAP,MYLAR(50V/0.1uF/J)				
C3006	943134010620S	CAP,ELECT(25V/4700uF)				
C3007	00MOA33802520	CAP,ELECT(25V/3300uF)				
C3008	943134502350S	CAP,ELECT(50V/470uF)				
C3012	943134502350S	CAP,ELECT(50V/470uF)				
C3013	943134502350S	CAP,ELECT(50V/470uF)				
C3025	nsp	CAP,CHIP(1608,50V/0.1uF,X7R)_SAMSUNG				
C3100	nsp	CAP,CHIP(1608,50V/1000pF,X7R)_SAMSUNG	E3			
! C6001	943132100650S	CAP,CERAMIC(X1/Y2,0.01uF,AC250V)				
! C6002	943132100650S	CAP,CERAMIC(X1/Y2,0.01uF,AC250V)				
! C6003	943132100650S	CAP,CERAMIC(X1/Y2,0.01uF,AC250V)				
C6004	943134501590S	CAP,ELECT(200V/100uF),105C	S720, E3, JP			
C6004	963134010200S	CAP,ELECT(400V/100UF,18X40,NHA)	E2, E1C			
C6007	nsp	CAP,CHIP(1608,50V/0.1uF,X7R)_SAMSUNG				
C6008	00D9430175108	CAP,ELECT(50V/10uF),105C				
C6009	nsp	CAP,CHIP(1608,50V/0.22uF,X5R)_SAMSUNG				
C6011	943132100640S	CAP,CHIP(3216,1000pF,DC1KV,MURATAGRM31)				
C6012	nsp	CAP,CHIP(1608,50V/0.1uF,X7R)_SAMSUNG				
C6013	00MOA47602520	CAP,ELECT(25V/47uF),105C				
C6014	nsp	CAP,CHIP(1608,50V/0.1uF,X7R)_SAMSUNG				
C6015	nsp	CAP,CHIP(1608,6.3V/4.7uF,X5R)_SAMSUNG				
C6018	963134010220S	CAP,ELECT(6.3V/5600uF)				
C6019	963134010220S	CAP,ELECT(6.3V/5600uF)				
C6020	nsp	CAP,CHIP(1608,50V/0.1uF,X7R)_SAMSUNG				
C6021	nsp	CAP,CHIP(1608,50V/0.1uF,X7R)_SAMSUNG				
! C6023	943132100670S	CAP,CERAMIC(X1/Y1,2200pF,AC250V)				
C6024	nsp	CAP,CHIP(1608,50V/0.1uF,X7R)_SAMSUNG				
C6026	943139500110S	CAP,CHIP(3216,1KV/47pF,C0G)_SAMSUNG				
C6029	nsp	CAP,CHIP(1608,50V/0.1uF,X7R)_SAMSUNG				

REF No.	Part No.	Part Name	Remarks	Q'ty	New	Ver
C6030	nsp	CAP,CHIP(1608,50V/0.015uF,X7R)_SAMSUNG		CCUS1H153KCS	1	
OTHER PARTS GROUP						
BK301	nsp	BRACKET,PCB		CMD1A569-V1	1	
BK302	nsp	BRACKET,PCB		CMD1A569-V1	1	
BK303	nsp	BRACKET,PCB		CMD1A387-V1	1	
BK601	nsp	BRACKET,PCBM3		CMD1A834	1	
BK602	nsp	BRACKET,PCBM3		CMD1A834	1	
BK603	nsp	BRACKET,PCB		CMD1A629	1	
BN301	nsp	WIREASS'YLocking(YH,5P,2.0MM,80MM,#24)		CWB1C005080HC	1	
BN302	nsp	WIRE ASS'Y Locking (YH) (3P,2MM,50MM,#28)	E3	CWB1A003050HC	1	
BN601	nsp	WIREASS'Y(YH,6P,2.5MM,130MM,#22,H/STUBE)		CWB1D006130BD001	1	*
CN302	nsp	WAFER/ANGLE/2.5mm/05P		CJP05GB03ZY	1	
CN601	nsp	WAFER,2P,3.96mm		CJP02KA060ZY	1	
CN602	nsp	WAFER,2P,7.92mm		CJP02GA89ZY	1	
! CX601	94313950020S	CAP,POLYPROPYLENEFILM		HCQF2E104KZE	1	
! CY601	943132100660S	CAP,CERAMIC(X1/Y1,470pF,AC250V)		CCKDKX471KBMF	1	*
! CY602	943132100660S	CAP,CERAMIC(X1/Y1,470pF,AC250V)		CCKDKX471KBMF	1	*
F3001	nsp	HOLDER,FUSE	E2, E1C, JP	KJCF5S	2	
F3002	nsp	HOLDER,FUSE	E2, E1C, JP	KJCF5S	2	
F3003	943652500510D	FUSE(932Series,250V/1.25A)	S720, E3	CBA2J1250TLEBT	1	
F3004	943652500510D	FUSE(932Series,250V/1.25A)	S720, E3	CBA2J1250TLEBT	1	
F6001	nsp	HOLDER,FUSE		KJCF5S	2	
! F6001	963652010510S	FUSE(S506Series,250V,2A)	S720, E3, JP	CBA2C2000TLEC	1	
! F6001	963652010500S	FUSE(S506 Series, 250V,1.6A)	E2, E1C	CBA2C1600TLEC	1	
F6002	nsp	HOLDER,FUSE		KJCF5S	2	
! F6002	90M-FS001430R	FUSE(218Series,250V/6.3A)	S720, E3, JP	KBA2C6300TLEY	1	
! F6002	0520100150000	FUSE(218Series, 250V/3.15A)	E2, E1C	KBA2C3150TLEY	1	
JK301	90M-YT004860R	JACK, STEREO (BLK MOLD)	E3	CJJ2D008Z	1	
L6001	nsp	RES,CHIP(1608/5%/0ohm)		CRJ10DJ0R0T	1	
! LF602	963111010230S	LINEFILTER,27mH	S720, E3, JP	CLZ9Z126Z	1	
! LF602	943111100410S	LINE FILTER, 50mH	E2, E1C	CLZ9Z133Z	1	
! RY601	963682010370S	RELAY,HL31-1AT-5H,DC5V,1C1P		CSL1C006ZE	1	
T6001	943102100720S	TRANS,SWITCHING		VLT9Z132ZW	1	

DIGITAL PCB ASS'Y

※Parts indicated by "nsp" on this table cannot be supplied. Part indicated by "*" mark is not illustrated in the exploded view
 ※The parts listed below are only for maintenance. Therefore they might differ from the parts used in the unit in appearances or dimensions
 NOTE: The symbols in the column Remarks indicate the following destinations.
 E3 : U.S.A. & Canada model E2 : Europe model E1C : China model E1 : Asia model JP : Japan model
 BK : Black model SP : Premium Silver model

REF No.	Part No.	Part Name	Remarks	Q'ty	New	Ver
SEMICONDUCTORS GROUP						
D7131	963209003510S	DIODE,RELIABLEESDPROTECTION				
D7401	201310001503S	DIODE,ULTRA-HIGHSPEED				
D7402	201310001503S	DIODE,ULTRA-HIGHSPEED				
D7403	201310001503S	DIODE,ULTRA-HIGHSPEED				
D7404	201310001503S	DIODE,ULTRA-HIGHSPEED				
D7502	201310001503S	DIODE,ULTRA-HIGHSPEED				
D7702	201310001503S	DIODE,ULTRA-HIGHSPEED				
D7703	201310001503S	DIODE,ULTRA-HIGHSPEED				
D7704	201310001503S	DIODE,ULTRA-HIGHSPEED				
D7705	201310001503S	DIODE,ULTRA-HIGHSPEED				
D8051	201310001503S	DIODE,ULTRA-HIGHSPEED				
D8201	943202501200S	DIODE,ZENER,1/2W,7.5V				
D8202	943202501200S	DIODE,ZENER,1/2W,7.5V				
D8203	201310001503S	DIODE,ULTRA-HIGHSPEED				
D8204	201310001503S	DIODE,ULTRA-HIGHSPEED				
D8205	943202501210S	DIODE,ZENER(3.6V/0.5W,SOD-123)				
D8206	201310001503S	DIODE,ULTRA-HIGHSPEED				
D8501	943202501220S	DIODE,ZENER(6.8V/0.5W,SOD-123)	E3			
D8502	943202501220S	DIODE,ZENER(6.8V/0.5W,SOD-123)	E3			
D8801	943202501230S	DIODE,ZENER(5.1V/0.5W,SOD-123)				
D8802	943202501230S	DIODE,ZENER(5.1V/0.5W,SOD-123)				
IC701	943236101940S	I.C,HDMI2.0Transceiver(HQFP-144P)				
IC721	23681050460AS	I.C,HDMI2.0Transceiver(HQFP-144P)				
IC731	943236012460S	I.C,HDMITransceiver(LQFP-144P)				
IC732	943248103710S	I.C,OSDSerialFlash(E3)MX25L3206EM2I-12G See PROCEDURE AFTER REPLACING THE U-COM, ETC.	S720, E3			
IC732	943248103720S	I.C, OSD Serial Flash (E1C)MX25L3206EM2I-12G See PROCEDURE AFTER REPLACING THE U-COM, ETC.	E1C			
IC732	943248103730S	I.C, OSD Serial Flash (K)MX25L3206EM2I-12G See PROCEDURE AFTER REPLACING THE U-COM, ETC.	JP			
IC732	943248103740S	I.C, OSD Serial Flash (E2)MX25L6406EM2I-12G See PROCEDURE AFTER REPLACING THE U-COM, ETC.	E2			
IC733	943239101510S	I.C,MUX/DEMUX(TSSOP-16P)				
IC741	943239101860S	I.C,DC-DCCONVERTER(SOT-23)				
IC742	943239101860S	I.C,DC-DCCONVERTER(SOT-23)				
IC743	943239101860S	I.C,DC-DCCONVERTER(SOT-23)				
IC744	943239101860S	I.C,DC-DCCONVERTER(SOT-23)				
IC745	943239101860S	I.C,DC-DCCONVERTER(SOT-23)				
IC747	943239101860S	I.C,DC-DCCONVERTER(SOT-23)				
IC749	943239010400S	I.C,REGULATOR(3.3V/TO-252)				
IC751	943243103310S	I.C,MAINMCU(E3)R5F56108VNFPP See PROCEDURE AFTER REPLACING THE U-COM, ETC.	S720, E3			
IC751	943243103320S	I.C, MAIN MCU(E2)R5F56108VNFPP See PROCEDURE AFTER REPLACING THE U-COM, ETC.	E2			
IC751	943243103330S	I.C, MAIN MCU(E1C)R5F56108VNFPP See PROCEDURE AFTER REPLACING THE U-COM, ETC.	E1C			
IC751	943243103340S	I.C, MAIN MCU(K)R5F56108VNFPP See PROCEDURE AFTER REPLACING THE U-COM, ETC.	JP			
IC752	943239101500S	I.C,EEPROM(128KBIT,SOP-8P)				
IC753	943233102030S	I.C,Shift/StoreRegister(SOIC-16P)				
IC761	963239002150S	I.C,OCTALBUFFER/DRIVER				
IC771	00D2623077900	I.C,HEXINVERTER	S720, E3			
IC772	943236101350D	I.C,DIR/DIT(WITHADC,LQFP-48P)				
IC773	943248103750S	I.C,PLD(AVRS720W/AVRX1300W)5M80ZT100C5N See PROCEDURE AFTER REPLACING THE U-COM, ETC.				
IC781	963245100680S	I.C,AUDIODSP(QUAD-CORE,LQFP-144P)				
IC782	943248103760S	I.C,DSPSerialFlash(AVRS720W/AVRX1300W)MX25L6406EM2I-12G See PROCEDURE AFTER REPLACING THE U-COM, ETC.				
IC783	963239002150S	I.C,OCTALBUFFER/DRIVER				
IC784	943246101180S	I.C,SDRAM64M(TSOPII-54P)				
IC791	943239101080S	I.C,DAC(8CH,HTSSOP-48)				
IC792	943232100380S	I.C,DUALOPAMP(SOP-8P)				
IC793	943232100380S	I.C,DUALOPAMP(SOP-8P)				
IC794	943232100380S	I.C,DUALOPAMP(SOP-8P)				
IC795	943232100380S	I.C,DUALOPAMP(SOP-8P)				
IC801	943239101090S	I.C,Highsideswitch(TSSOP-B8)				
IC802	23671011050AS	I.C,IPODAUTHENTICATIONFROMD&M				
IC803	24681009260AS	I.C,SERIALFLASH(256M,SOP-16)MX25L25635FMI-10G See PROCEDURE AFTER REPLACING THE U-COM, ETC.				
IC804	943239101520S	I.C,0-BITBUFFER/DRIVERTSSOP24TEXASINSTRUMENTS				
IC805	943239100690S	I.C,2CHDAC(32BIT,384KHZ,TSSOP-20P)				
IC806	943231102150S	I.C,regulator(3.3V,SSOP5)				
IC821	943235100520S	I.C,INPUTWITH8CHVOLUME(52PLQFP)				
IC851	90M-HC109850R	I.C, VIDEO 2CH	E3			
IC852	943232100380S	I.C, DUAL OPAMP(SOP-8P)	E3			
IC881	90M-HC109700R	I.C,VIDEOS/W(JRC)				
Q7101	943216500020S	T.R,RT1N141C(10K-10K)				
Q7102	943216500020S	T.R,RT1N141C(10K-10K)				
Q7111	943216500020S	T.R,RT1N141C(10K-10K)				
Q7112	943216500020S	T.R,RT1N141C(10K-10K)				
Q7121	943216500020S	T.R,RT1N141C(10K-10K)				
Q7122	943216500020S	T.R,RT1N141C(10K-10K)				
Q7201	943216500020S	T.R,RT1N141C(10K-10K)				
Q7202	943216500020S	T.R,RT1N141C(10K-10K)				
Q7211	943216500020S	T.R,RT1N141C(10K-10K)				
Q7212	943216500020S	T.R,RT1N141C(10K-10K)				
Q7401	943216500050S	T.R,RT1N441C(47K-47K)				
Q7402	00D2757001907	MOSFET(P-CH,2.5VPOWER/TRENCH)				
Q7403	943216500020S	T.R,RT1N141C(10K-10K)				
Q7404	00D2757001907	MOSFET(P-CH,2.5VPOWER/TRENCH)				
Q7405	943216500050S	T.R,RT1N441C(47K-47K)				
Q7406	00D2757001907	MOSFET(P-CH,2.5VPOWER/TRENCH)				
Q7407	943216500050S	T.R,RT1N441C(47K-47K)				
Q7408	00D2757001907	MOSFET(P-CH,2.5VPOWER/TRENCH)				
Q7409	943216500050S	T.R,RT1N441C(47K-47K)				
Q7410	00D2757001907	MOSFET(P-CH,2.5VPOWER/TRENCH)				
Q7411	943216500050S	T.R,RT1N441C(47K-47K)				
Q7412	00D2757001907	MOSFET(P-CH,2.5VPOWER/TRENCH)				
Q7413	943216500020S	T.R,RT1N141C(10K-10K)				
Q7414	00D2757001907	MOSFET(P-CH,2.5VPOWER/TRENCH)				
Q7415	943216500020S	T.R,RT1N141C(10K-10K)				
Q7416	00D2757001907	MOSFET(P-CH,2.5VPOWER/TRENCH)				
Q7417	963212500030S	T.R,ISA1530AC1				
Q7418	943216500020S	T.R,RT1N141C(10K-10K)				
Q7419	943214500020S	T.R,2SC3052				
Q7420	963212500030S	T.R,ISA1530AC1				
Q7421	943216500020S	T.R,RT1N141C(10K-10K)				
Q7422	963212500030S	T.R,ISA1530AC1				
Q7423	943216500020S	T.R,RT1N141C(10K-10K)				

REF No.	Part No.	Part Name	Remarks	Q'ty	New	Ver
Q7424	963212500030S	T.R,ISA1530AC1		1		
Q7501	943214500030S	T.R,MUTE		1		
Q7502	943214500020S	T.R,2SC3052		1		
Q7503	943214500020S	T.R,2SC3052		1		
Q7601	943216500020S	T.R,RT1N141C(10K-10K)		1		
Q7602	943216500020S	T.R,RT1N141C(10K-10K)		1		
Q7603	943216500020S	T.R,RT1N141C(10K-10K)		1		
Q7604	943216500020S	T.R,RT1N141C(10K-10K)		1		
Q7605	943214500020S	T.R,2SC3052		1		
Q7606	943214500020S	T.R,2SC3052		1		
Q7607	943214500020S	T.R,2SC3052		1		
Q7801	943216500020S	T.R,RT1N141C(10K-10K)		1		
Q8001	943216500020S	T.R,RT1N141C(10K-10K)		1		
Q8201	943215500030S	T.R,RT1P441C(47K-47K)		1		
Q8202	943216500050S	T.R,RT1N441C(47K-47K)		1		
Q8203	943215500030S	T.R,RT1P441C(47K-47K)		1		
Q8205	943214500030S	T.R,MUTE		1		
Q8501	943215500030S	T.R,RT1P441C(47K-47K)	E3	1		
Q8502	943215500030S	T.R,RT1P441C(47K-47K)	E3	1		
Q8503	943215500030S	T.R,RT1P441C(47K-47K)	E3	1		
Q8506	943214500030S	T.R , MUTE	E3	1		
Q8507	943214500030S	T.R , MUTE	E3	1		
RESISTOR GROUP						
R7101	nsp	RES.CHIP(1005/5%/1Kohm)		1		
R7102	nsp	RES.CHIP(1005/5%/10Kohm)		1		
R7103	nsp	RES.CHIP(1005/5%/47Kohm)		1		
R7104	nsp	RES.CHIP(1005/5%/47Kohm)		1		
R7105	nsp	RES.CHIP(1005/5%/47Kohm)		1		
R7106	nsp	RES.CHIP(1005/5%/0ohm)		1		
R7107	nsp	RES.CHIP(1005/5%/0ohm)		1		
R7108	nsp	RES.CHIP(1005/5%/0ohm)		1		
R7111	nsp	RES.CHIP(1005/5%/1Kohm)		1		
R7112	nsp	RES.CHIP(1005/5%/10Kohm)		1		
R7113	nsp	RES.CHIP(1005/5%/47Kohm)		1		
R7114	nsp	RES.CHIP(1005/5%/47Kohm)		1		
R7115	nsp	RES.CHIP(1005/5%/47Kohm)		1		
R7116	nsp	RES.CHIP(1005/5%/0ohm)		1		
R7117	nsp	RES.CHIP(1005/5%/0ohm)		1		
R7118	nsp	RES.CHIP(1005/5%/0ohm)		1		
R7121	nsp	RES.CHIP(1005/5%/1Kohm)		1		
R7122	nsp	RES.CHIP(1005/5%/10Kohm)		1		
R7123	nsp	RES.CHIP(1005/5%/47Kohm)		1		
R7124	nsp	RES.CHIP(1005/5%/47Kohm)		1		
R7125	nsp	RES.CHIP(1005/5%/47Kohm)		1		
R7126	nsp	RES.CHIP(1005/5%/0ohm)		1		
R7127	nsp	RES.CHIP(1005/5%/0ohm)		1		
R7128	nsp	RES.CHIP(1005/5%/0ohm)		1		
R7131	nsp	RES.CHIP(1005/5%/10Kohm)		1		
R7132	nsp	RES.CHIP(1005/5%/10Kohm)		1		
R7133	nsp	RES.CHIP(1005/5%/10Kohm)		1		
R7134	nsp	RES.CHIP(1005/5%/10Kohm)		1		
R7135	nsp	RES.CHIP(1005/5%/47Kohm)		1		
R7136	nsp	RES.CHIP(1005/5%/47ohm)		1		
R7137	nsp	RES.CHIP(1005/5%/1Kohm)		1		
R7138	nsp	RES.CHIP(1005/5%/47ohm)		1		
R7140	nsp	RES.CHIP(1005/5%/2Kohm)		1		
R7141	nsp	RES.CHIP(1005/5%/2Kohm)		1		
R7142	nsp	RES.CHIP(1005/5%/0ohm)		1		
R7143	nsp	RES.CHIP(1005/5%/47ohm)		1		
R7144	nsp	RES.CHIP(1005/5%/10Kohm)		1		
R7145	nsp	RES.CHIP(1005/5%/10Kohm)		1		
R7146	nsp	RES.CHIP(1005/5%/10Kohm)		1		
R7147	nsp	RES.CHIP(1005/5%/1Mohm)		1		
R7148	nsp	RES.CHIP(1005/5%/1Kohm)		1		
R7149	nsp	RES.CHIP(1005/5%/10Kohm)		1		
R7152	nsp	RES.CHIP(1005/5%/47Kohm)		1		
R7201	nsp	RES.CHIP(1005/5%/1Kohm)		1		
R7202	nsp	RES.CHIP(1005/5%/10Kohm)		1		
R7203	nsp	RES.CHIP(1005/5%/47Kohm)		1		
R7204	nsp	RES.CHIP(1005/5%/47Kohm)		1		
R7205	nsp	RES.CHIP(1005/5%/47Kohm)		1		
R7206	nsp	RES.CHIP(1005/5%/0ohm)		1		
R7207	nsp	RES.CHIP(1005/5%/0ohm)		1		
R7208	nsp	RES.CHIP(1005/5%/0ohm)		1		
R7211	nsp	RES.CHIP(1005/5%/1Kohm)		1		
R7212	nsp	RES.CHIP(1005/5%/10Kohm)		1		
R7213	nsp	RES.CHIP(1005/5%/47Kohm)		1		
R7214	nsp	RES.CHIP(1005/5%/47Kohm)		1		
R7215	nsp	RES.CHIP(1005/5%/47Kohm)		1		
R7216	nsp	RES.CHIP(1005/5%/0ohm)		1		
R7217	nsp	RES.CHIP(1005/5%/0ohm)		1		
R7218	nsp	RES.CHIP(1005/5%/0ohm)		1		
R7221	nsp	RES.CHIP(1005/5%/10Kohm)		1		
R7222	nsp	RES.CHIP(1005/5%/33ohm)		1		
R7224	nsp	RES.CHIP(1005/5%/10Kohm)		1		
R7225	nsp	RES.CHIP(1005/5%/10Kohm)		1		
R7226	nsp	RES.CHIP(1005/5%/10Kohm)		1		
R7227	nsp	RES.CHIP(1005/5%/10Kohm)		1		
R7228	nsp	RES.CHIP(1005/5%/10Kohm)		1		
R7229	nsp	RES.CHIP(1005/5%/47ohm)		1		
R7230	nsp	RES.CHIP(1005/5%/1Kohm)		1		
R7231	nsp	RES.CHIP(1005/5%/47ohm)		1		
R7232	nsp	RES.CHIP(1005/5%/100ohm)		1		
R7233	nsp	RES.CHIP(1005/5%/100ohm)		1		
R7234	nsp	RES.CHIP(1005/5%/100ohm)		1		
R7235	nsp	RES.CHIP(1005/5%/33ohm)		1		
R7236	nsp	RES.CHIP(1005/5%/33ohm)		1		
R7237	nsp	RES.CHIP(1005/5%/33ohm)		1		
R7238	nsp	RES.CHIP(1005/5%/33ohm)		1		
R7242	nsp	RES.CHIP(1005/5%/0ohm)		1		
R7245	nsp	RES.CHIP(1005/5%/10Kohm)		1		
R7246	nsp	RES.CHIP(1005/5%/47ohm)		1		
R7247	nsp	RES.CHIP(1005/5%/1Mohm)		1		
R7248	nsp	RES.CHIP(1005/5%/1Kohm)		1		
R7251	nsp	RES.CHIP(1005/5%/10Kohm)		1		
R7252	nsp	RES.CHIP(1005/5%/10Kohm)		1		
R7253	nsp	RES.CHIP(1005/5%/0ohm)		1		
R7254	nsp	RES.CHIP(1005/5%/0ohm)		1		
R7255	nsp	RES.CHIP(1005/5%/10Kohm)		1		
R7256	nsp	RES.CHIP(1005/5%/1.8Kohm)		1		
R7257	nsp	RES.CHIP(1005/5%/1.8Kohm)		1		
R7258	nsp	RES.CHIP(1005/5%/0ohm)		1		
R7259	nsp	RES.CHIP(1608/1%/51ohm)		1		
R7260	nsp	RES.CHIP(1608/1%/51ohm)		1		
R7301	nsp	RES.CHIP(1005/5%/10Kohm)		1		
R7302	nsp	RES.CHIP(1608/1%/1.6Kohm)		1		
R7303	nsp	RES.CHIP(1608/1%/2Kohm)		1		
CRJ06J102T				1		
CRJ06J103T				1		
CRJ06J473T				1		
CRJ06J473T				1		
CRJ06J473T				1		
CRJ06J0R0T				1		
CRJ06J0R0T				1		
CRJ06J0R0T				1		
CRJ06J102T				1		
CRJ06J103T				1		
CRJ06J473T				1		
CRJ06J473T				1		
CRJ06J473T				1		
CRJ06J0R0T				1		
CRJ06J0R0T				1		
CRJ06J0R0T				1		
CRJ06J102T				1		
CRJ06J103T				1		
CRJ06J103T				1		
CRJ06J103T				1		
CRJ06J473T				1		
CRJ06J470T				1		
CRJ06J102T				1		
CRJ06J470T				1		
CRJ06J202T				1		
CRJ06J202T				1		
CRJ06J0R0T				1		
CRJ06J470T				1		
CRJ06J103T				1		
CRJ06J103T				1		
CRJ06J103T				1		
CRJ06J103T				1		
CRJ06J473T				1		
CRJ06J102T				1		
CRJ06J103T				1		
CRJ06J473T				1		
CRJ06J473T				1		
CRJ06J473T				1		
CRJ06J0R0T				1		
CRJ06J0R0T				1		
CRJ06J102T				1		
CRJ06J103T				1		
CRJ06J473T				1		
CRJ06J473T				1		
CRJ06J473T				1		
CRJ06J0R0T				1		
CRJ06J0R0T				1		
CRJ06J103T				1		
CRJ06J103T				1		
CRJ06J103T				1		
CRJ06J103T				1		
CRJ06J473T				1		
CRJ06J102T				1		
CRJ06J103T				1		
CRJ06J473T				1		
CRJ06J473T				1		
CRJ06J473T				1		
CRJ06J0R0T				1		
CRJ06J0R0T				1		
CRJ06J102T				1		
CRJ06J103T				1		
CRJ06J473T				1		
CRJ06J473T				1		
CRJ06J473T				1		
CRJ06J0R0T				1		
CRJ06J0R0T				1		
CRJ06J103T				1		
CRJ06J103T				1		
CRJ06J103T				1		
CRJ06J103T				1		
CRJ06J470T				1		
CRJ06J102T				1		
CRJ06J470T				1		
CRJ06J101T				1		
CRJ06J101T				1		
CRJ06J101T				1		
CRJ06J101T				1		
CRJ06J330T				1		
CRJ06J330T				1		
CRJ06J330T				1		
CRJ06J330T				1		
CRJ06J0R0T				1		
CRJ06J103T				1		
CRJ06J470T				1		
CRJ06J105T				1		
CRJ06J102T				1		
CRJ06J103T				1		
CRJ06J103T				1		
CRJ06J0R0T				1		
CRJ06J103T				1		
CRJ06J182T				1		
CRJ06J182T				1		
CRJ06J0R0T				1		
CRJ10DF51R0T				1		
CRJ10DF51R0T				1		
CRJ06J103T				1		
CRJ10DF1601T				1		
CRJ10DF2001T				1		

REF No.	Part No.	Part Name	Remarks	Q'ty	New	Ver
R7304	nsp	RES.CHIP(1005/5%/10Kohm)	CRJ06J103T	1		
R7305	nsp	RES.CHIP(1005/5%/10Kohm)	CRJ06J103T	1		
R7306	nsp	RES.CHIP(1005/5%/47Kohm)	CRJ06J473T	1		
R7308	nsp	RES.CHIP(1005/5%/47Kohm)	CRJ06J473T	1		
R7310	nsp	RES.CHIP(1005/5%/33ohm)	CRJ06J330T	1		
R7311	nsp	RES.CHIP(1005/5%/33ohm)	CRJ06J330T	1		
R7312	nsp	RES.CHIP(1005/5%/33ohm)	CRJ06J330T	1		
R7314	nsp	RES.CHIP(1005/5%/33ohm)	CRJ06J330T	1		
R7315	nsp	RES.CHIP(1005/5%/10Kohm)	CRJ06J103T	1		
R7316	nsp	RES.CHIP(1005/5%/10Kohm)	CRJ06J103T	1		
R7317	nsp	RES.CHIP(1005/5%/10Kohm)	CRJ06J103T	1		
R7318	nsp	RES.CHIP(1005/5%/10Kohm)	CRJ06J103T	1		
R7319	nsp	RES.CHIP(1005/5%/10Kohm)	CRJ06J103T	1		
R7320	nsp	RES.CHIP(1005/5%/10Kohm)	CRJ06J103T	1		
R7321	nsp	RES.CHIP(1005/5%/10Kohm)	CRJ06J103T	1		
R7322	nsp	RES.CHIP(1005/5%/10Kohm)	CRJ06J103T	1		
R7323	nsp	RES.CHIP(1608/5%/100ohm)	CRJ10DJ101T	1		
R7324	nsp	RES.CHIP(1608/5%/100ohm)	CRJ10DJ101T	1		
R7326	nsp	RES.CHIP(1608/5%/1Kohm)	CRJ10DJ102T	1		
R7327	nsp	RES.CHIP(1005/5%/10Kohm)	CRJ06J103T	1		
R7329	nsp	RES.CHIP(1005/5%/1Mohm)	CRJ06J105T	1		
R7330	nsp	RES.CHIP(1005/5%/0ohm)	CRJ06J0R0T	1		
R7331	nsp	RES.CHIP(1005/1%/1Kohm)	CRJ06JF1001T	1		
R7332	nsp	RES.CHIP(1005/1%/1Kohm)	CRJ06JF1001T	1		
R7333	nsp	RES.CHIP(1005/5%/10Kohm)	CRJ06J103T	1		
R7334	nsp	RES.CHIP(1005/5%/4.7Kohm)	CRJ06J472T	1		
R7335	nsp	RES.CHIP(1005/5%/10Kohm)	CRJ06J103T	1		
R7340	nsp	RES.CHIP(1005/5%/1.8Kohm)	CRJ06J182T	1		
R7341	nsp	RES.CHIP(1005/5%/1.8Kohm)	CRJ06J182T	1		
R7342	nsp	RES.CHIP(1005/5%/10Kohm)	CRJ06J103T	1		
R7345	nsp	RES.CHIP(1005/5%/10Kohm)	CRJ06J103T	1		
R7348	nsp	RES.CHIP(1005/5%/4.7Kohm)	CRJ06J472T	1		
R7349	nsp	RES.CHIP(1005/5%/4.7Kohm)	CRJ06J472T	1		
R7350	nsp	RES.CHIP(1005/5%/100ohm)	CRJ06J101T	1		
R7351	nsp	RES.CHIP(1005/5%/100ohm)	CRJ06J101T	1		
R7352	nsp	RES.CHIP(1005/5%/100ohm)	CRJ06J101T	1		
R7353	nsp	RES.CHIP(1005/5%/100ohm)	CRJ06J101T	1		
R7354	nsp	RES.CHIP(1005/5%/2.2Kohm)	CRJ06J222T	1		
R7355	nsp	RES.CHIP(1005/5%/8.2Kohm)	CRJ06J822T	1		
R7401	nsp	RES.CHIP(1005/5%/10Kohm)	CRJ06J103T	1		
R7402	nsp	RES.CHIP(1005/5%/10Kohm)	CRJ06J103T	1		
R7403	nsp	RES.CHIP(1005/5%/4.7Kohm)	CRJ06J472T	1		
R7404	nsp	RES.CHIP(1005/5%/47Kohm)	CRJ06J473T	1		
R7405	nsp	RES.CHIP(1005/5%/100Kohm)	CRJ06J104T	1		
R7406	nsp	RES.CHIP(1005/5%/100ohm)	CRJ06J101T	1		
R7407	nsp	RES.CHIP(1005/5%/10Kohm)	CRJ06J103T	1		
R7408	nsp	RES.CHIP(1005/5%/3.3Kohm)	CRJ06J332T	1		
R7409	nsp	RES.CHIP(1005/5%/10Kohm)	CRJ06J103T	1		
R7410	nsp	RES.CHIP(1005/5%/3.3Kohm)	CRJ06J332T	1		
R7411	nsp	RES.CHIP(1005/5%/33ohm)	CRJ06J330T	1		
R7412	nsp	RES.CHIP(1608/5%/100Kohm)	CRJ10DJ104T	1		
R7413	nsp	RES.CHIP(1608/1%/10Kohm)	CRJ10DF1002T	1		
R7415	nsp	RES.CHIP(1608/1%/33.2Kohm)	CRJ10DF3322T	1	*	
R7416	nsp	RES.CHIP(1608/5%/0ohm)	CRJ10DJ0R0T	1		
R7417	nsp	RES.CHIP(1005/5%/47Kohm)	CRJ06J473T	1		
R7421	nsp	RES.CHIP(1005/5%/33ohm)	CRJ06J330T	1		
R7422	nsp	RES.CHIP(1608/5%/100Kohm)	CRJ10DJ104T	1		
R7423	nsp	RES.CHIP(1608/1%/10Kohm)	CRJ10DF1002T	1		
R7425	nsp	RES.CHIP(1608/1%/22.6Kohm)	CRJ10DF2262T	1	*	
R7426	nsp	RES.CHIP(1608/5%/0ohm)	CRJ10DJ0R0T	1		
R7431	nsp	RES.CHIP(1005/5%/33ohm)	CRJ06J330T	1		
R7432	nsp	RES.CHIP(1608/5%/100Kohm)	CRJ10DJ104T	1		
R7433	nsp	RES.CHIP(1608/1%/10Kohm)	CRJ10DF1002T	1		
R7435	nsp	RES.CHIP(1608/1%/6.49Kohm)	CRJ10DF6491T	1	*	
R7436	nsp	RES.CHIP(1608/5%/0ohm)	CRJ10DJ0R0T	1		
R7437	nsp	RES.CHIP(2012/5%/100ohm)	CRJ18AJ101T	1		
R7441	nsp	RES.CHIP(1005/5%/33ohm)	CRJ06J330T	1		
R7442	nsp	RES.CHIP(1608/5%/100Kohm)	CRJ10DJ104T	1		
R7443	nsp	RES.CHIP(1608/1%/10Kohm)	CRJ10DF1002T	1		
R7445	nsp	RES.CHIP(1608/1%/13.7Kohm)	CRJ10DF1372T	1	*	
R7446	nsp	RES.CHIP(1608/5%/0ohm)	CRJ10DJ0R0T	1		
R7447	nsp	RES.CHIP(1005/5%/47Kohm)	CRJ06J473T	1		
R7451	nsp	RES.CHIP(1005/5%/33ohm)	CRJ06J330T	1		
R7452	nsp	RES.CHIP(1608/5%/100Kohm)	CRJ10DJ104T	1		
R7453	nsp	RES.CHIP(1608/1%/10Kohm)	CRJ10DF1002T	1		
R7455	nsp	RES.CHIP(1608/1%/3.09Kohm)	CRJ10DF3091T	1	*	
R7456	nsp	RES.CHIP(1608/5%/0ohm)	CRJ10DJ0R0T	1		
R7461	90M-NN000640R	RES.CHIP(1608/5%/2.7ohm)	CRJ10DJ2R7T	1		
R7462	90M-NN000640R	RES.CHIP(1608/5%/2.7ohm)	CRJ10DJ2R7T	1		
R7463	90M-NN000640R	RES.CHIP(1608/5%/2.7ohm)	CRJ10DJ2R7T	1		
R7464	nsp	RES.CHIP(1608/5%/10Kohm)	CRJ10DJ103T	1		
R7465	nsp	RES.CHIP(1005/5%/1Kohm)	CRJ06J102T	1		
R7466	nsp	RES.CHIP(1608/5%/10Kohm)	CRJ10DJ103T	1		
R7467	nsp	RES.CHIP(1608/5%/10Kohm)	CRJ10DJ103T	1		
R7468	nsp	RES.CHIP(1608/5%/10Kohm)	CRJ10DJ103T	1		
R7469	nsp	RES.CHIP(1005/5%/2Kohm)	CRJ06J202T	1		
R7470	nsp	RES.CHIP(1005/5%/2Kohm)	CRJ06J202T	1		
R7471	nsp	RES.CHIP(1005/5%/33ohm)	CRJ06J330T	1		
R7472	nsp	RES.CHIP(1608/5%/100Kohm)	CRJ10DJ104T	1		
R7473	nsp	RES.CHIP(1608/1%/10Kohm)	CRJ10DF1002T	1		
R7475	nsp	RES.CHIP(1608/1%/4.7Kohm)	CRJ10DF4701T	1	*	
R7476	nsp	RES.CHIP(1608/5%/0ohm)	CRJ10DJ0R0T	1		
R7482	nsp	RES.CHIP(1005/5%/10Kohm)	CRJ06J103T	1		
R7484	nsp	RES.CHIP(1005/5%/27Kohm)	CRJ06J273T	1		
R7486	nsp	RES.CHIP(1005/5%/10Kohm)	CRJ06J103T	1		
R7488	nsp	RES.CHIP(1005/5%/10Kohm)	CRJ06J103T	1		
R7490	nsp	RES.CHIP(1005/5%/10Kohm)	CRJ06J103T	1		
R7491	nsp	RES.CHIP(1005/5%/10Kohm)	CRJ06J103T	1		
R7492	nsp	RES.CHIP(1005/5%/10Kohm)	CRJ06J103T	1		
R7494	nsp	RES.CHIP(1005/5%/18Kohm)	CRJ06J183T	1		
R7496	nsp	RES.CHIP(1005/5%/18Kohm)	CRJ06J183T	1		
R7497	nsp	RES.CHIP(1005/5%/10Kohm)	CRJ06J103T	1		
R7498	nsp	RES.CHIP(1005/5%/3.3Kohm)	CRJ06J332T	1		
R7499	nsp	RES.CHIP(1608/5%/0ohm)	CRJ10DJ0R0T	1		
R7501	nsp	RES.CHIP(1005/5%/33ohm)	CRJ06J330T	1		
R7502	nsp	RES.CHIP(1005/5%/33ohm)	CRJ06J330T	1		
R7503	nsp	RES.CHIP(1005/5%/33ohm)	CRJ06J330T	1		
R7504	nsp	RES.CHIP(1005/5%/33ohm)	CRJ06J330T	1		
R7505	nsp	RES.CHIP(1005/5%/4.7Kohm)	CRJ06J472T	1		
R7506	nsp	RES.CHIP(1005/5%/0ohm)	CRJ06J0R0T	1		
R7507	nsp	RES.CHIP(1608/5%/1Mohm)	CRJ10DJ105T	1		
R7508	nsp	RES.CHIP(1005/5%/10Kohm)	CRJ06J103T	1		
R7509	nsp	RES.CHIP(1005/5%/33ohm)	CRJ06J330T	1		
R7510	nsp	RES.CHIP(1005/5%/33ohm)	CRJ06J330T	1		
R7511	nsp	RES.CHIP(1005/5%/75ohm)	CRJ06J750T	1		
R7512	nsp	RES.CHIP(1005/5%/75ohm)	CRJ06J750T	1		
R7513	nsp	RES.CHIP(1005/5%/75ohm)	CRJ06J750T	1		

REF No.	Part No.	Part Name	Remarks	Q'ty	New	Ver
R7514	nsp	RES.CHIP(1005/5%/33ohm)		1		
R7515	nsp	RES.CHIP(1005/5%/0ohm)		1		
R7516	nsp	RES.CHIP(1005/5%/33ohm)		1		
R7517	nsp	RES.CHIP(1608/5%/33ohm)		1		
R7518	nsp	RES.CHIP(1608/5%/33ohm)		1		
R7519	nsp	RES.CHIP(1005/5%/33ohm)		1		
R7520	nsp	RES.CHIP(1005/5%/33ohm)		1		
R7521	nsp	RES.CHIP(1005/5%/33ohm)		1		
R7522	nsp	RES.CHIP(1608/5%/33ohm)		1		
R7523	nsp	RES.CHIP(1608/5%/33ohm)		1		
R7524	nsp	RES.CHIP(1005/5%/10Kohm)		1		
R7525	nsp	RES.CHIP(1005/5%/10Kohm)		1		
R7527	nsp	RES.CHIP(1005/5%/33ohm)		1		
R7529	nsp	RES.CHIP(1005/5%/33ohm)		1		
R7530	nsp	RES.CHIP(1005/5%/33ohm)		1		
R7531	nsp	RES.CHIP(1005/5%/33ohm)		1		
R7532	nsp	RES.CHIP(1005/5%/33ohm)		1		
R7533	nsp	RES.CHIP(1005/5%/33ohm)		1		
R7534	nsp	RES.CHIP(1005/5%/33ohm)		1		
R7535	nsp	RES.CHIP(1005/5%/33ohm)		1		
R7539	nsp	RES.CHIP(1005/5%/33ohm)		1		
R7540	nsp	RES.CHIP(1005/5%/33ohm)		1		
R7541	nsp	RES.CHIP(1005/5%/33ohm)		1		
R7542	nsp	RES.CHIP(1005/5%/33ohm)		1		
R7543	nsp	RES.CHIP(1005/5%/33ohm)		1		
R7544	nsp	RES.CHIP(1005/5%/33ohm)		1		
R7545	nsp	RES.CHIP(1005/5%/33ohm)		1		
R7546	nsp	RES.CHIP(1005/5%/33ohm)		1		
R7547	nsp	RES.CHIP(1005/5%/33ohm)		1		
R7548	nsp	RES.CHIP(1005/5%/33ohm)		1		
R7549	nsp	RES.CHIP(1005/5%/33ohm)		1		
R7550	nsp	RES.CHIP(1005/5%/33ohm)		1		
R7551	nsp	RES.CHIP(1005/5%/33ohm)		1		
R7552	nsp	RES.CHIP(1005/5%/33ohm)		1		
R7553	nsp	RES.CHIP(1005/5%/1Kohm)		1		
R7554	nsp	RES.CHIP(1005/5%/1Kohm)		1		
R7555	nsp	RES.CHIP(1005/5%/1Kohm)		1		
R7556	nsp	RES.CHIP(1005/5%/10Kohm)		1		
R7557	nsp	RES.CHIP(1005/5%/100ohm)		1		
R7558	nsp	RES.CHIP(1005/5%/10Kohm)		1		
R7559	nsp	RES.CHIP(1005/5%/4.7Kohm)		1		
R7560	nsp	RES.CHIP(1005/5%/10Kohm)		1		
R7561	nsp	RES.CHIP(1005/5%/4.7Kohm)		1		
R7562	nsp	RES.CHIP(1005/5%/4.7Kohm)		1		
R7563	nsp	RES.CHIP(1005/5%/4.7Kohm)		1		
R7564	nsp	RES.CHIP(1005/5%/4.7Kohm)		1		
R7565	nsp	RES.CHIP(1005/5%/4.7Kohm)		1		
R7566	nsp	RES.CHIP(1608/5%/0ohm)		1		
R7567	nsp	RES.CHIP(1005/5%/4.7Kohm)		1		
R7568	nsp	RES.CHIP(1005/5%/4.7Kohm)		1		
R7569	nsp	RES.CHIP(1005/5%/10Kohm)		1		
R7570	nsp	RES.CHIP(1005/5%/100Kohm)		1		
R7571	nsp	RES.CHIP(1005/5%/2.2Mohm)		1		
R7572	nsp	RES.CHIP(1005/5%/4.7Kohm)		1		
R7573	nsp	RES.CHIP(1005/5%/47Kohm)		1		
R7574	nsp	RES.CHIP(1005/5%/100Kohm)		1		
R7575	nsp	RES.CHIP(1005/5%/220Kohm)		1		
R7576	nsp	RES.CHIP(1005/5%/27Kohm)		1		
R7577	nsp	RES.CHIP(1005/5%/1.2Kohm)		1		
R7578	nsp	RES.CHIP(1005/5%/3.3Kohm)		1		
R7580	nsp	RES.CHIP(1005/5%/33ohm)		1		
R7581	nsp	RES.CHIP(1608/5%/18Kohm)	S720	1		
R7581	nsp	RES.CHIP(1608/5%/0ohm)	E2	1		
R7581	nsp	RES.CHIP(1608/5%/10Kohm)	E1C, JP	1		
R7582	nsp	RES.CHIP(1608/5%/3.3Kohm)	S720	1		
R7582	nsp	RES.CHIP(1608/5%/0ohm)	E3	1		
R7582	nsp	RES.CHIP(1608/5%/22Kohm)	JP	1		
R7582	nsp	RES.CHIP(1608/5%/10Kohm)	E1C	1		
R7583	nsp	RES.CHIP(1005/5%/10Kohm)		1		
R7601	nsp	RES.CHIP(1005/5%/33ohm)		1		
R7602	nsp	RES.CHIP(1005/5%/33ohm)		1		
R7603	nsp	RES.CHIP(1005/5%/33ohm)		1		
R7604	nsp	RES.CHIP(1608/5%/100ohm)		1		
R7605	nsp	RES.CHIP(1608/5%/100ohm)		1		
R7606	nsp	RES.CHIP(1608/5%/100ohm)		1		
R7607	nsp	RES.CHIP(1608/5%/100ohm)		1		
R7608	nsp	RES.CHIP(1608/5%/4.7Kohm)		1		
R7609	nsp	RES.CHIP(1005/5%/33ohm)		1		
R7610	nsp	RES.CHIP(1005/5%/4.7Kohm)		1		
R7611	nsp	RES.CHIP(1005/5%/3.9Kohm)		1		
R7612	nsp	RES.CHIP(1005/5%/4.7Kohm)		1		
R7613	nsp	RES.CHIP(1005/5%/3.3Kohm)		1		
R7617	nsp	RES.CHIP(1005/5%/10Kohm)		1		
R7618	nsp	RES.CHIP(1005/5%/10Kohm)		1		
R7619	nsp	RES.CHIP(1005/5%/3.3Kohm)		1		
R7623	nsp	RES.CHIP(1005/5%/3.9Kohm)		1		
R7624	nsp	RES.CHIP(1005/5%/100ohm)		1		
R7625	nsp	RES.CHIP(1005/5%/100ohm)		1		
R7626	nsp	RES.CHIP(1608/5%/120Kohm)		1		
R7627	nsp	RES.CHIP(1005/5%/22Kohm)		1		
R7628	nsp	RES.CHIP(1005/5%/100ohm)		1		
R7629	nsp	RES.CHIP(1608/5%/120Kohm)		1		
R7630	nsp	RES.CHIP(1005/5%/22Kohm)		1		
R7701	nsp	RES.CHIP(1005/5%/33ohm)		1		
R7702	nsp	RES.CHIP(1005/5%/33ohm)		1		
R7703	nsp	RES.CHIP(1005/5%/150ohm)	S720, E3	1		
R7704	nsp	RES.CHIP(1005/5%/150ohm)	S720, E3	1		
R7705	nsp	RES.CHIP(1005/5%/470ohm)	S720, E3	1		
R7708	nsp	RES.CHIP(1005/5%/47Kohm)	S720, E3	1		
R7709	nsp	RES.CHIP(1608/5%/330Kohm)	S720, E3	1		
R7710	nsp	RES.CHIP(1005/5%/33ohm)	S720, E3	1		
R7712	nsp	RES.CHIP(1005/5%/0ohm)	E3	1		
R7713	nsp	RES.CHIP(1608/5%/100Kohm)		1		
R7714	nsp	RES.CHIP(1608/5%/100Kohm)		1		
R7715	nsp	RES.CHIP(1608/5%/91ohm)		1		
R7716	nsp	RES.CHIP(1005/5%/4.7Kohm)		1		
R7717	nsp	RES.CHIP(1005/5%/4.7Kohm)		1		
R7718	nsp	RES.CHIP(1005/5%/4.7Kohm)		1		
R7719	nsp	RES.CHIP(1005/5%/4.7Kohm)		1		
R7720	nsp	RES.CHIP(1005/5%/4.7Kohm)		1		
R7721	nsp	RES.CHIP(1005/5%/3.3Kohm)		1		
R7722	nsp	RES.CHIP(1005/5%/33ohm)		1		
R7723	nsp	RES.CHIP(1005/5%/4.7Kohm)		1		
R7724	nsp	RES.CHIP(1005/5%/4.7Kohm)		1		
R7725	nsp	RES.CHIP(1005/5%/100ohm)		1		
R7726	nsp	RES.CHIP(1005/5%/47Kohm)		1		
R7727	nsp	RES.CHIP(1005/5%/4.7Kohm)		1		

REF No.	Part No.	Part Name	Remarks	Q'ty	New	Ver
R7729	nsp	RES.CHIP(1608/5%/680ohm)	CRJ10DJ681T	1		
R7730	nsp	RES.CHIP(1608/5%/100ohm)	CRJ10DJ101T	1		
R7731	nsp	RES.CHIP(1608/5%/100ohm)	CRJ10DJ101T	1		
R7738	nsp	RES.CHIP(1005/5%/33ohm)	CRJ06J330T	1		
R7739	nsp	RES.CHIP(1005/5%/33ohm)	CRJ06J330T	1		
R7751	nsp	RES.CHIP(1005/5%/100ohm)	CRJ06J101T	1		
R7752	nsp	RES.CHIP(1005/5%/33ohm)	CRJ06J330T	1		
R7753	nsp	RES.CHIP(1005/5%/33ohm)	CRJ06J330T	1		
R7754	nsp	RES.CHIP(1005/5%/33ohm)	CRJ06J330T	1		
R7755	nsp	RES.CHIP(1005/5%/100ohm)	CRJ06J101T	1		
R7756	nsp	RES.CHIP(1005/5%/33ohm)	CRJ06J330T	1		
R7757	nsp	RES.CHIP(1608/5%/33ohm)	CRJ10DJ330T	1		
R7758	nsp	RES.CHIP(1608/5%/33ohm)	CRJ10DJ330T	1		
R7759	nsp	RES.CHIP(1608/5%/33ohm)	CRJ10DJ330T	1		
R7760	nsp	RES.CHIP(1608/5%/91ohm)	CRJ10DJ910T	1		
R7761	nsp	RES.CHIP(1005/5%/0ohm)	CRJ06J0R0T	1		
R7762	nsp	RES.CHIP(1608/5%/33ohm)	CRJ10DJ330T	1		
R7763	nsp	RES.CHIP(1608/5%/33ohm)	CRJ10DJ330T	1		
R7764	nsp	RES.CHIP(1608/5%/33ohm)	CRJ10DJ330T	1		
R7765	nsp	RES.CHIP(1005/5%/1Kohm)	CRJ06J102T	1		
R7766	nsp	RES.CHIP(1005/5%/10Kohm)	CRJ06J103T	1		
R7767	nsp	RES.CHIP(1005/5%/10Kohm)	CRJ06J103T	1		
R7768	nsp	RES.CHIP(1005/5%/10Kohm)	CRJ06J103T	1		
R7769	nsp	RES.CHIP(1005/5%/10Kohm)	CRJ06J103T	1		
R7770	nsp	RES.CHIP(1005/5%/10Kohm)	CRJ06J103T	1		
R7771	nsp	RES.CHIP(1005/5%/100ohm)	CRJ06J101T	1		
R7772	nsp	RES.CHIP(1005/5%/100ohm)	CRJ06J101T	1		
R7773	nsp	RES.CHIP(1005/5%/100ohm)	CRJ06J101T	1		
R7774	nsp	RES.CHIP(1005/5%/100ohm)	CRJ06J101T	1		
R7775	nsp	RES.CHIP(1005/5%/33ohm)	CRJ06J330T	1		
R7801	nsp	RES.CHIP(1005/5%/33ohm)	CRJ06J330T	1		
R7802	nsp	RES.CHIP(1005/5%/33ohm)	CRJ06J330T	1		
R7803	nsp	RES.CHIP(1005/5%/0ohm)	CRJ06J0R0T	1		
R7804	nsp	RES.CHIP(1005/5%/33ohm)	CRJ06J330T	1		
R7805	nsp	RES.CHIP(1005/5%/33ohm)	CRJ06J330T	1		
R7806	nsp	RES.CHIP(1005/5%/33ohm)	CRJ06J330T	1		
R7807	nsp	RES.CHIP(1005/5%/3.3Kohm)	CRJ06J332T	1		
R7809	nsp	RES.CHIP(1005/5%/100ohm)	CRJ06J101T	1		
R7810	nsp	RES.CHIP(1005/5%/33ohm)	CRJ06J330T	1		
R7811	nsp	RES.CHIP(1005/5%/33ohm)	CRJ06J330T	1		
R7812	nsp	RES.CHIP(1005/5%/2Kohm)	CRJ06J202T	1		
R7813	nsp	RES.CHIP(1005/5%/2Kohm)	CRJ06J202T	1		
R7814	nsp	RES.CHIP(1005/5%/33ohm)	CRJ06J330T	1		
R7815	nsp	RES.CHIP(1005/5%/33ohm)	CRJ06J330T	1		
R7818	nsp	RES.CHIP(1608/5%/33ohm)	CRJ10DJ330T	1		
R7821	nsp	RES.CHIP(1608/5%/1Mohm)	CRJ10DJ105T	1		
R7822	nsp	RES.CHIP(1005/5%/0ohm)	CRJ06J0R0T	1		
R7823	nsp	RES.CHIP(1608/5%/20Kohm)	CRJ10DJ203T	1		
R7824	nsp	RES.CHIP(1608/5%/100ohm)	CRJ10DJ101T	1		
R7826	nsp	RES.CHIP(1608/5%/3.3Kohm)	CRJ10DJ332T	1		
R7827	nsp	RES.CHIP(1608/5%/3.3Kohm)	CRJ10DJ332T	1		
R7829	nsp	RES.CHIP(1608/5%/3.3Kohm)	CRJ10DJ332T	1		
R7832	nsp	RES.CHIP(1608/5%/3.3Kohm)	CRJ10DJ332T	1		
R7833	nsp	RES.CHIP(1005/5%/4.7Kohm)	CRJ06J472T	1		
R7835	nsp	RES.CHIP(1005/5%/33ohm)	CRJ06J330T	1		
R7836	nsp	RES.CHIP(1005/5%/3.3Kohm)	CRJ06J332T	1		
R7837	nsp	RES.CHIP(1005/5%/3.3Kohm)	CRJ06J332T	1		
R7838	nsp	RES.CHIP(1005/5%/33ohm)	CRJ06J330T	1		
R7839	nsp	RES.CHIP(1608/5%/33ohm)	CRJ10DJ330T	1		
R7840	nsp	RES.CHIP(1608/5%/33ohm)	CRJ10DJ330T	1		
R7841	nsp	RES.CHIP(1005/5%/33ohm)	CRJ06J330T	1		
R7842	nsp	RES.CHIP(1005/5%/10Kohm)	CRJ06J103T	1		
R7843	nsp	RES.CHIP(1005/5%/10Kohm)	CRJ06J103T	1		
R7844	nsp	RES.CHIP(1005/5%/33ohm)	CRJ06J330T	1		
R7846	nsp	RES.CHIP(1005/5%/10Kohm)	CRJ06J103T	1		
R7847	nsp	RES.CHIP(1005/5%/10Kohm)	CRJ06J103T	1		
R7848	nsp	RES.CHIP(1005/5%/10Kohm)	CRJ06J103T	1		
R7849	nsp	RES.CHIP(1005/5%/10Kohm)	CRJ06J103T	1		
R7850	nsp	RES.CHIP(1005/5%/10Kohm)	CRJ06J103T	1		
R7855	nsp	RES.CHIP(1005/5%/10Kohm)	CRJ06J103T	1		
R7856	nsp	RES.CHIP(1005/5%/10Kohm)	CRJ06J103T	1		
R7857	nsp	RES.CHIP(1005/5%/10Kohm)	CRJ06J103T	1		
R7858	nsp	RES.CHIP(1005/5%/10Kohm)	CRJ06J103T	1		
R7860	nsp	RES.CHIP(1005/5%/33ohm)	CRJ06J330T	1		
R7861	nsp	RES.CHIP(1005/5%/33ohm)	CRJ06J330T	1		
R7862	nsp	RES.CHIP(1005/5%/33ohm)	CRJ06J330T	1		
R7863	nsp	RES.CHIP(1005/5%/10Kohm)	CRJ06J103T	1		
R7864	nsp	RES.CHIP(1005/5%/10Kohm)	CRJ06J103T	1		
R7865	nsp	RES.CHIP(1005/5%/10Kohm)	CRJ06J103T	1		
R7901	nsp	RES.CHIP(1608/5%/33ohm)	CRJ10DJ330T	1		
R7902	nsp	RES.CHIP(1005/5%/1Kohm)	CRJ06J102T	1		
R7903	nsp	RES.CHIP(1608/5%/4.7Kohm)	CRJ10DJ472T	1		
R7904	nsp	RES.CHIP(1608/5%/4.7Kohm)	CRJ10DJ472T	1		
R7907	nsp	RES.CHIP(1608/5%/0ohm)	CRJ10DJ0R0T	1		
R7908	nsp	RES.CHIP(1608/5%/0ohm)	CRJ10DJ0R0T	1		
R7911	nsp	RES.CHIP(1608/0.5%/15Kohm)	CRJ06DD153TP	1		
R7912	nsp	RES.CHIP(1608/0.5%/15Kohm)	CRJ06DD153TP	1		
R7913	nsp	RES.CHIP(1608/5%/150Kohm)	CRJ10DJ154T	1		
R7914	nsp	RES.CHIP(1608/0.5%/12Kohm)	CRJ06DD123TP	1		
R7915	nsp	RES.CHIP(1608/5%/470ohm)	CRJ10DJ471T	1		
R7916	nsp	RES.CHIP(1608/5%/150Kohm)	CRJ10DJ154T	1		
R7917	nsp	RES.CHIP(1608/0.5%/12Kohm)	CRJ06DD123TP	1		
R7918	nsp	RES.CHIP(1608/5%/470ohm)	CRJ10DJ471T	1		
R7919	nsp	RES.CHIP(1608/5%/100ohm)	CRJ10DJ101T	1		
R7921	nsp	RES.CHIP(1608/0.5%/15Kohm)	CRJ06DD153TP	1		
R7922	nsp	RES.CHIP(1608/0.5%/15Kohm)	CRJ06DD153TP	1		
R7923	nsp	RES.CHIP(1608/5%/150Kohm)	CRJ10DJ154T	1		
R7924	nsp	RES.CHIP(1608/0.5%/12Kohm)	CRJ06DD123TP	1		
R7925	nsp	RES.CHIP(1608/5%/470ohm)	CRJ10DJ471T	1		
R7926	nsp	RES.CHIP(1608/5%/470ohm)	CRJ10DJ471T	1		
R7927	nsp	RES.CHIP(1608/0.5%/12Kohm)	CRJ06DD123TP	1		
R7928	nsp	RES.CHIP(1608/5%/150Kohm)	CRJ10DJ154T	1		
R7929	nsp	RES.CHIP(1608/5%/100ohm)	CRJ10DJ101T	1		
R7931	nsp	RES.CHIP(1608/0.5%/15Kohm)	CRJ06DD153TP	1		
R7932	nsp	RES.CHIP(1608/0.5%/15Kohm)	CRJ06DD153TP	1		
R7933	nsp	RES.CHIP(1608/5%/150Kohm)	CRJ10DJ154T	1		
R7934	nsp	RES.CHIP(1608/0.5%/12Kohm)	CRJ06DD123TP	1		
R7935	nsp	RES.CHIP(1608/5%/470ohm)	CRJ10DJ471T	1		
R7936	nsp	RES.CHIP(1608/5%/150Kohm)	CRJ10DJ154T	1		
R7937	nsp	RES.CHIP(1608/0.5%/12Kohm)	CRJ06DD123TP	1		
R7938	nsp	RES.CHIP(1608/5%/470ohm)	CRJ10DJ471T	1		
R7939	nsp	RES.CHIP(1608/5%/100ohm)	CRJ10DJ101T	1		
R7941	nsp	RES.CHIP(1608/0.5%/15Kohm)	CRJ06DD153TP	1		
R7942	nsp	RES.CHIP(1608/0.5%/15Kohm)	CRJ06DD153TP	1		
R7943	nsp	RES.CHIP(1608/5%/120Kohm)	CRJ10DJ124T	1		
R7944	nsp	RES.CHIP(1608/0.5%/39Kohm)	CRJ06DD393TP	1		
R7945	nsp	RES.CHIP(1608/5%/1Kohm)	CRJ10DJ102T	1		

REF No.	Part No.	Part Name	Remarks	Q'ty	New	Ver
R7946	nsp	RES.CHIP(1608/5%/1Kohm)	CRJ10DJ102T	1		
R7947	nsp	RES.CHIP(1608/0.5%/39Kohm)	CRJ06DD393TP	1		
R7948	nsp	RES.CHIP(1608/5%/120Kohm)	CRJ10DJ124T	1		
R7949	nsp	RES.CHIP(1608/5%/100ohm)	CRJ10DJ101T	1		
R7951	nsp	RES.CHIP(1608/0.5%/15Kohm)	CRJ06DD153TP	1		
R7952	nsp	RES.CHIP(1608/0.5%/15Kohm)	CRJ06DD153TP	1		
R7953	nsp	RES.CHIP(1608/5%/150Kohm)	CRJ10DJ154T	1		
R7954	nsp	RES.CHIP(1608/0.5%/12Kohm)	CRJ06DD123TP	1		
R7955	nsp	RES.CHIP(1608/5%/470ohm)	CRJ10DJ471T	1		
R7956	nsp	RES.CHIP(1608/5%/150Kohm)	CRJ10DJ154T	1		
R7957	nsp	RES.CHIP(1608/0.5%/12Kohm)	CRJ06DD123TP	1		
R7958	nsp	RES.CHIP(1608/5%/470ohm)	CRJ10DJ471T	1		
R7959	nsp	RES.CHIP(1608/5%/100ohm)	CRJ10DJ101T	1		
R7961	nsp	RES.CHIP(1608/0.5%/15Kohm)	CRJ06DD153TP	1		
R7962	nsp	RES.CHIP(1608/0.5%/15Kohm)	CRJ06DD153TP	1		
R7963	nsp	RES.CHIP(1608/5%/150Kohm)	CRJ10DJ154T	1		
R7964	nsp	RES.CHIP(1608/0.5%/12Kohm)	CRJ06DD123TP	1		
R7965	nsp	RES.CHIP(1608/5%/470ohm)	CRJ10DJ471T	1		
R7966	nsp	RES.CHIP(1608/5%/470ohm)	CRJ10DJ471T	1		
R7967	nsp	RES.CHIP(1608/0.5%/12Kohm)	CRJ06DD123TP	1		
R7968	nsp	RES.CHIP(1608/5%/150Kohm)	CRJ10DJ154T	1		
R7969	nsp	RES.CHIP(1608/5%/100ohm)	CRJ10DJ101T	1		
R7971	nsp	RES.CHIP(1608/0.5%/15Kohm)	CRJ06DD153TP	1		
R7972	nsp	RES.CHIP(1608/0.5%/15Kohm)	CRJ06DD153TP	1		
R7973	nsp	RES.CHIP(1608/5%/150Kohm)	CRJ10DJ154T	1		
R7974	nsp	RES.CHIP(1608/0.5%/12Kohm)	CRJ06DD123TP	1		
R7975	nsp	RES.CHIP(1608/5%/470ohm)	CRJ10DJ471T	1		
R7976	nsp	RES.CHIP(1608/5%/150Kohm)	CRJ10DJ154T	1		
R7977	nsp	RES.CHIP(1608/0.5%/12Kohm)	CRJ06DD123TP	1		
R7978	nsp	RES.CHIP(1608/5%/470ohm)	CRJ10DJ471T	1		
R7979	nsp	RES.CHIP(1608/5%/100ohm)	CRJ10DJ101T	1		
R7981	nsp	RES.CHIP(1608/0.5%/15Kohm)	CRJ06DD153TP	1		
R7982	nsp	RES.CHIP(1608/0.5%/15Kohm)	CRJ06DD153TP	1		
R7983	nsp	RES.CHIP(1608/5%/150Kohm)	CRJ10DJ154T	1		
R7984	nsp	RES.CHIP(1608/0.5%/12Kohm)	CRJ06DD123TP	1		
R7985	nsp	RES.CHIP(1608/5%/470ohm)	CRJ10DJ471T	1		
R7986	nsp	RES.CHIP(1608/5%/470ohm)	CRJ10DJ471T	1		
R7987	nsp	RES.CHIP(1608/0.5%/12Kohm)	CRJ06DD123TP	1		
R7988	nsp	RES.CHIP(1608/5%/150Kohm)	CRJ10DJ154T	1		
R7989	nsp	RES.CHIP(1608/5%/100ohm)	CRJ10DJ101T	1		
R8001	nsp	RES.CHIP(1005/5%/10Kohm)	CRJ06J103T	1		
R8002	nsp	RES.CHIP(1005/5%/100ohm)	CRJ06J101T	1		
R8003	nsp	RES.CHIP(1005/5%/100ohm)	CRJ06J101T	1		
R8004	nsp	RES.CHIP(1005/5%/100ohm)	CRJ06J101T	1		
R8005	nsp	RES.CHIP(1005/5%/100ohm)	CRJ06J101T	1		
R8006	nsp	RES.CHIP(1005/5%/10Kohm)	CRJ06J103T	1		
R8010	nsp	RES.CHIP(1005/5%/10Kohm)	CRJ06J103T	1		
R8011	nsp	RES.CHIP(1005/5%/0ohm)	CRJ06J0R0T	1		
R8013	nsp	RES.CHIP(1005/5%/0ohm)	CRJ06J0R0T	1		
R8015	nsp	RES.CHIP(1005/5%/33ohm)	CRJ06J330T	1		
R8016	nsp	RES.CHIP(1005/5%/33ohm)	CRJ06J330T	1		
R8017	nsp	RES.CHIP(1005/5%/33ohm)	CRJ06J330T	1		
R8019	nsp	RES.CHIP(1005/5%/33ohm)	CRJ06J330T	1		
R8020	nsp	RES.CHIP(1005/5%/33ohm)	CRJ06J330T	1		
R8021	nsp	RES.CHIP(1005/5%/10Kohm)	CRJ06J103T	1		
R8022	nsp	RES.CHIP(1005/5%/10Kohm)	CRJ06J103T	1		
R8026	nsp	RES.CHIP(1005/5%/0ohm)	CRJ06J0R0T	1		
R8027	nsp	RES.CHIP(1005/5%/0ohm)	CRJ06J0R0T	1		
R8028	nsp	RES.CHIP(1005/5%/47ohm)	CRJ06J470T	1		
R8034	nsp	RES.CHIP(1005/5%/33ohm)	CRJ06J330T	1		
R8035	nsp	RES.CHIP(1005/5%/10Kohm)	CRJ06J103T	1		
R8036	nsp	RES.CHIP(1005/5%/47Kohm)	CRJ06J473T	1		
R8037	nsp	RES.CHIP(1005/5%/10Kohm)	CRJ06J103T	1		
R8038	nsp	RES.CHIP(1005/5%/47ohm)	CRJ06J470T	1		
R8040	nsp	RES.CHIP(1005/5%/100ohm)	CRJ06J101T	1		
R8041	nsp	RES.CHIP(1005/5%/100ohm)	CRJ06J100T	1		
R8042	nsp	RES.CHIP(1608/5%/0ohm)	CRJ10DJ0R0T	1		
R8043	nsp	RES.CHIP(1608/5%/0ohm)	CRJ10DJ0R0T	1		
R8044	nsp	RES.CHIP(1608/5%/0ohm)	CRJ10DJ0R0T	1		
R8045	nsp	RES.CHIP(1608/5%/0ohm)	CRJ10DJ0R0T	1		
R8055	nsp	RES.CHIP(1005/5%/10Kohm)	CRJ06J103T	1		
R8057	nsp	RES.CHIP(1005/5%/10Kohm)	CRJ06J103T	1		
R8058	nsp	RES.CHIP(1608/5%/10Kohm)	CRJ10DJ103T	1		
R8060	nsp	RES.CHIP(1005/5%/10Kohm)	CRJ06J103T	1		
R8061	nsp	RES.CHIP(1005/5%/470ohm)	CRJ06J471T	1		
R8062	nsp	RES.CHIP(1005/5%/470ohm)	CRJ06J471T	1		
R8063	nsp	RES.CHIP(1608/5%/0ohm)	CRJ10DJ0R0T	1		
R8064	nsp	RES.CHIP(1608/5%/0ohm)	CRJ10DJ0R0T	1		
R8075	nsp	RES.CHIP(1005/5%/10Kohm)	CRJ06J103T	1		
R8201	nsp	RES.CHIP(1608/5%/270ohm)	CRJ10DJ271T	1		
R8202	nsp	RES.CHIP(1608/5%/270ohm)	CRJ10DJ271T	1		
R8203	nsp	RES.CHIP(1608/5%/27Kohm)	CRJ10DJ273T	1		
R8204	nsp	RES.CHIP(1005/5%/0ohm)	CRJ06J0R0T	1		
R8205	nsp	RES.CHIP(1608/5%/27Kohm)	CRJ10DJ273T	1		
R8206	nsp	RES.CHIP(1005/5%/0ohm)	CRJ06J0R0T	1		
R8207	nsp	RES.CHIP(1608/5%/100ohm)	CRJ10DJ101T	1		
R8208	nsp	RES.CHIP(1608/5%/33ohm)	CRJ10DJ330T	1		
R8209	nsp	RES.CHIP(1608/5%/100ohm)	CRJ10DJ101T	1		
R8213	nsp	RES.CHIP(1608/5%/100ohm)	CRJ10DJ101T	1		
R8214	nsp	RES.CHIP(1608/5%/100ohm)	CRJ10DJ101T	1		
R8215	nsp	RES.CHIP(1608/5%/1Mohm)	CRJ10DJ105T	1		
R8216	nsp	RES.CHIP(1608/5%/1Mohm)	CRJ10DJ105T	1		
R8217	nsp	RES.CHIP(1608/5%/100ohm)	CRJ10DJ101T	1		
R8218	nsp	RES.CHIP(1608/5%/100ohm)	CRJ10DJ101T	1		
R8219	nsp	RES.CHIP(1608/5%/1Mohm)	CRJ10DJ105T	1		
R8220	nsp	RES.CHIP(1608/5%/1Mohm)	CRJ10DJ105T	1		
R8221	nsp	RES.CHIP(1608/5%/0ohm)	CRJ10DJ0R0T	1		
R8222	nsp	RES.CHIP(1608/5%/470ohm)	CRJ10DJ471T	1		
R8223	nsp	RES.CHIP(1608/5%/470ohm)	CRJ10DJ471T	1		
R8224	nsp	RES.CHIP(1608/5%/470ohm)	CRJ10DJ471T	1		
R8225	nsp	RES.CHIP(1608/5%/470ohm)	CRJ10DJ471T	1		
R8226	nsp	RES.CHIP(1608/5%/470ohm)	CRJ10DJ471T	1		
R8227	nsp	RES.CHIP(1608/5%/470ohm)	CRJ10DJ471T	1		
R8228	nsp	RES.CHIP(1608/5%/470ohm)	CRJ10DJ471T	1		
R8229	nsp	RES.CHIP(1608/5%/100ohm)	CRJ10DJ101T	1		
R8230	nsp	RES.CHIP(1608/5%/100ohm)	CRJ10DJ101T	1		
R8231	nsp	RES.CHIP(1608/5%/100ohm)	CRJ10DJ101T	1		
R8236	nsp	RES.CHIP(1608/5%/0ohm)	CRJ10DJ0R0T	1		
R8237	nsp	FERRITECHIPBEAD(1608/60R.CB03YTYH600)	CLZ9R005V	1		
R8238	nsp	FERRITECHIPBEAD(1608/60R.CB03YTYH600)	CLZ9R005V	1		
R8239	nsp	FERRITECHIPBEAD(1608/60R.CB03YTYH600)	CLZ9R005V	1		
R8240	nsp	RES.M-OXIDEFILM(1W/150ohm)	CRG1SANJ151RT	1		
R8241	nsp	RES.M-OXIDEFILM(1W/150ohm)	CRG1SANJ151RT	1		
R8242	nsp	RES.CHIP(1608/5%/0ohm)	CRJ10DJ0R0T	1		
R8243	nsp	RES.CHIP(1608/5%/0ohm)	CRJ10DJ0R0T	1		
R8244	nsp	RES.CHIP(1608/5%/0ohm)	CRJ10DJ0R0T	1		
R8245	nsp	RES.CHIP(1608/5%/100Kohm)	CRJ10DJ104T	1		

REF No.	Part No.	Part Name	Remarks	Q'ty	New	Ver
R8246	nsp	RES.CHIP(1608/5%/100Kohm)		CRJ10DJ104T	1	
R8247	nsp	RES.CHIP(1608/5%/100Kohm)		CRJ10DJ104T	1	
R8248	nsp	RES.CHIP(1608/5%/100Kohm)		CRJ10DJ104T	1	
R8249	nsp	RES.CHIP(1608/5%/100Kohm)		CRJ10DJ104T	1	
R8250	nsp	RES.CHIP(1608/5%/100Kohm)		CRJ10DJ104T	1	
R8251	nsp	RES.CHIP(1608/5%/100Kohm)		CRJ10DJ104T	1	
R8252	nsp	RES.CHIP(1608/5%/100Kohm)		CRJ10DJ104T	1	
R8253	nsp	RES.CHIP(1608/5%/100Kohm)		CRJ10DJ104T	1	
R8254	nsp	RES.CHIP(1608/5%/100Kohm)		CRJ10DJ104T	1	
R8255	nsp	RES.CHIP(1608/5%/820ohm)		CRJ10DJ821T	1	
R8256	nsp	RES.CHIP(1608/5%/0ohm)		CRJ10DJ0R0T	1	
R8257	nsp	RES.CHIP(1608/5%/10Kohm)		CRJ10DJ103T	1	
R8258	nsp	RES.CHIP(1608/5%/10Kohm)		CRJ10DJ103T	1	
R8259	nsp	RES.CHIP(1608/5%/1Kohm)		CRJ10DJ102T	1	
R8260	nsp	RES.CHIP(1608/5%/470Kohm)		CRJ10DJ474T	1	
R8261	nsp	RES.CHIP(1608/5%/10Kohm)		CRJ10DJ103T	1	
R8263	nsp	RES.CHIP(1608/5%/470ohm)		CRJ10DJ471T	1	
R8264	nsp	RES.CHIP(1608/5%/470ohm)		CRJ10DJ471T	1	
R8265	nsp	RES.CHIP(1608/5%/100Kohm)		CRJ10DJ104T	1	
R8266	nsp	RES.CHIP(1608/5%/100Kohm)		CRJ10DJ104T	1	
R8267	nsp	RES.CHIP(1608/5%/220ohm)		CRJ10DJ221T	1	
R8271	nsp	RES.CHIP(1608/5%/0ohm)		CRJ10DJ0R0T	1	
R8501	nsp	RES. M-OXIDE FILM(1W/470ohm)	E3	CRG1SANJ471RT	1	
R8502	nsp	RES. M-OXIDE FILM(1W/470ohm)	E3	CRG1SANJ471RT	1	
R8503	nsp	RES.CHIP(1608/5%/100Kohm)	E3	CRJ10DJ104T	1	
R8504	nsp	RES.CHIP(1608/5%/100Kohm)	E3	CRJ10DJ104T	1	
R8505	nsp	RES.CHIP(1608/5%/100ohm)	E3	CRJ10DJ101T	1	
R8506	nsp	RES.CHIP(1608/5%/100ohm)	E3	CRJ10DJ101T	1	
R8507	nsp	RES.CHIP(1608/5%/47Kohm)	E3	CRJ10DJ473T	1	
R8508	nsp	RES.CHIP(1608/5%/47Kohm)	E3	CRJ10DJ473T	1	
R8509	nsp	RES.CHIP(1608/5%/2.2Kohm)	E3	CRJ10DJ222T	1	
R8510	nsp	RES.CHIP(1608/5%/2.2Kohm)	E3	CRJ10DJ222T	1	
R8511	nsp	RES.CHIP(1608/5%/11Kohm)	E3	CRJ10DJ113T	1	
R8512	nsp	RES.CHIP(1608/5%/11Kohm)	E3	CRJ10DJ113T	1	
R8513	nsp	RES.CHIP(1608/5%/100ohm)	E3	CRJ10DJ101T	1	
R8514	nsp	RES.CHIP(1608/5%/100ohm)	E3	CRJ10DJ101T	1	
R8515	nsp	RES.CHIP(1608/5%/10Kohm)	E3	CRJ10DJ103T	1	
R8516	nsp	RES.CHIP(1608/5%/1Kohm)	E3	CRJ10DJ102T	1	
R8517	nsp	RES.CHIP(1608/5%/470Kohm)	E3	CRJ10DJ474T	1	
R8518	nsp	RES.CHIP(1608/5%/10Kohm)	E3	CRJ10DJ103T	1	
R8521	nsp	RES.CHIP(1608/5%/10Kohm)	E3	CRJ10DJ103T	1	
R8522	nsp	RES.CHIP(1608/5%/470ohm)	E3	CRJ10DJ471T	1	
R8523	nsp	RES.CHIP(1608/5%/470ohm)	E3	CRJ10DJ471T	1	
R8524	nsp	RES.CHIP(1608/5%/470ohm)	E3	CRJ10DJ471T	1	
R8525	nsp	RES.CHIP(1608/5%/470ohm)	E3	CRJ10DJ471T	1	
R8526	nsp	RES.CHIP(1608/5%/100Kohm)	E3	CRJ10DJ104T	1	
R8527	nsp	RES.CHIP(1608/5%/100Kohm)	E3	CRJ10DJ104T	1	
R8528	nsp	RES.CHIP(1608/5%/100Kohm)	E3	CRJ10DJ104T	1	
R8529	nsp	RES.CHIP(1608/5%/100Kohm)	E3	CRJ10DJ104T	1	
R8530	nsp	RES.CHIP(1608/5%/220ohm)	E3	CRJ10DJ221T	1	
R8531	nsp	RES.CHIP(1608/5%/220ohm)	E3	CRJ10DJ221T	1	
R8532	nsp	RES.CHIP(1608/5%/10Kohm)	E3	CRJ10DJ103T	1	
R8801	nsp	RES.CHIP(1608/1%/75ohm)		CRJ10DF75R0T	1	
R8802	nsp	RES.CHIP(1608/1%/75ohm)		CRJ10DF75R0T	1	
R8803	nsp	RES.CHIP(1608/5%/1.8Kohm)		CRJ10DJ182T	1	
R8804	nsp	RES.CHIP(1608/1%/82ohm)		CRJ10DF82R0T	1	
R8805	nsp	RES.CHIP(1608/5%/10Kohm)		CRJ10DJ103T	1	
R8806	nsp	RES.M-OXIDEFILM(1W/270ohm)		CRG1SANJ271RT	1	
R8807	nsp	RES.M-OXIDEFILM(1W/270ohm)		CRG1SANJ271RT	1	
R8808	nsp	RES.CHIP(1608/5%/0ohm)		CRJ10DJ0R0T	1	
R9093	nsp	RES.CHIP(1005/5%/10Kohm)		CRJ06J103T	1	
RN713	nsp	RES.CHIP(1005/5%/0ohm*2)		CRJ062J0R0T	1	
RN714	nsp	RES.CHIP(1005/5%/0ohm*2)		CRJ062J0R0T	1	
RN715	nsp	RES.CHIP(1005/5%/0ohm*2)		CRJ062J0R0T	1	
RN716	nsp	RES.CHIP(1005/5%/0ohm*2)		CRJ062J0R0T	1	
RN721	nsp	RES.CHIP(1005/5%/0ohm*2)		CRJ062J0R0T	1	
RN722	nsp	RES.CHIP(1005/5%/0ohm*2)		CRJ062J0R0T	1	
RN723	nsp	RES.CHIP(1005/5%/0ohm*2)		CRJ062J0R0T	1	
RN724	943113100000S	COMMONMODEFILTER(1210.90ohm)		CLZ9Z188Z	1	
RN725	nsp	RES.CHIP(1005/5%/10ohm*4)		CRJ064J100T	1	
RN761	nsp	RES.CHIP(1005/5%/33ohm*2)		CRJ062J330T	1	
RN762	nsp	RES.CHIP(1005/5%/100ohm*4)		CRJ064J101T	1	
RN765	nsp	RES.CHIP(1005/5%/33ohm*4)		CRJ064J330T	1	
RN766	nsp	RES.CHIP(1005/5%/33ohm*2)		CRJ062J330T	1	
RN767	nsp	RES.CHIP(1005/5%/33ohm*4)		CRJ064J330T	1	
RN768	nsp	RES.CHIP(1005/5%/33ohm*4)		CRJ064J330T	1	
RN769	nsp	RES.CHIP(1005/5%/33ohm*2)		CRJ062J330T	1	
RN781	nsp	RES.CHIP(1005/5%/33ohm*4)		CRJ064J330T	1	
RN782	nsp	RES.CHIP(1005/5%/33ohm*4)		CRJ064J330T	1	
RN783	nsp	RES.CHIP(1005/5%/33ohm*2)		CRJ062J330T	1	
RN784	nsp	RES.CHIP(1005/5%/33ohm*4)		CRJ064J330T	1	
RN785	nsp	RES.CHIP(1005/5%/33ohm*4)		CRJ064J330T	1	
RN786	nsp	RES.CHIP(1005/5%/33ohm*4)		CRJ064J330T	1	
RN787	nsp	RES.CHIP(1005/5%/33ohm*4)		CRJ064J330T	1	
RN788	nsp	RES.CHIP(1005/5%/33ohm*4)		CRJ064J330T	1	
RN789	nsp	RES.CHIP(1005/5%/33ohm*4)		CRJ064J330T	1	
RN790	nsp	RES.CHIP(1005/5%/33ohm*4)		CRJ064J330T	1	
RN791	nsp	RES.CHIP(1005/5%/33ohm*4)		CRJ064J330T	1	
RN792	nsp	RES.CHIP(1005/5%/33ohm*4)		CRJ064J330T	1	
RN793	nsp	RES.CHIP(1005/5%/33ohm*4)		CRJ064J330T	1	
RN794	nsp	RES.CHIP(1005/5%/33ohm*4)		CRJ064J330T	1	
RN795	nsp	RES.CHIP(1005/5%/33ohm*4)		CRJ064J330T	1	
RN801	nsp	RES.CHIP(1005/5%/100ohm*4)		CRJ064J101T	1	
RN802	nsp	RES.CHIP(1005/5%/47ohm*4)		CRJ064J470T	1	
RN803	nsp	RES.CHIP(1005/5%/47ohm*4)		CRJ064J470T	1	
RN804	nsp	RES.CHIP(1005/5%/0ohm*2)		CRJ062J0R0T	1	
RN805	nsp	RES.CHIP(1005/5%/100ohm*4)		CRJ064J101T	1	
RN806	nsp	RES.CHIP(1005/5%/100ohm*4)		CRJ064J101T	1	
CAPACITORS GROUP						
C7101	nsp	CAP.CHIP(1005.16V/0.1uF.X7R)_SAMSUNG		CCU1C104KCS	1	
C7102	nsp	CAP.CHIP(1005.16V/0.1uF.X7R)_SAMSUNG		CCU1C104KCS	1	
C7103	nsp	CAP.CHIP(1005.16V/0.1uF.X7R)_SAMSUNG		CCU1C104KCS	1	
C7104	nsp	CAP.CHIP(1005.16V/0.1uF.X7R)_SAMSUNG		CCU1C104KCS	1	
C7105	nsp	CAP.CHIP(1005.16V/0.1uF.X7R)_SAMSUNG		CCU1C104KCS	1	
C7106	nsp	CAP.CHIP(1005.16V/0.1uF.X7R)_SAMSUNG		CCU1C104KCS	1	
C7107	nsp	CAP.CHIP(1005.16V/0.1uF.X7R)_SAMSUNG		CCU1C104KCS	1	
C7108	nsp	CAP.CHIP(1005.16V/0.1uF.X7R)_SAMSUNG		CCU1C104KCS	1	
C7109	nsp	CAP.CHIP(1005.16V/0.1uF.X7R)_SAMSUNG		CCU1C104KCS	1	
C7110	nsp	CAP.CHIP(1005.16V/0.1uF.X7R)_SAMSUNG		CCU1C104KCS	1	
C7111	nsp	CAP.CHIP(1005.16V/0.1uF.X7R)_SAMSUNG		CCU1C104KCS	1	
C7112	nsp	CAP.CHIP(1005.16V/0.1uF.X7R)_SAMSUNG		CCU1C104KCS	1	
C7113	nsp	CAP.CHIP(1005.16V/0.1uF.X7R)_SAMSUNG		CCU1C104KCS	1	
C7120	nsp	CAP.CHIP(1005.16V/0.1uF.X7R)_SAMSUNG		CCU1C104KCS	1	
C7121	nsp	CAP.CHIP(1005.16V/0.1uF.X7R)_SAMSUNG		CCU1C104KCS	1	
C7122	nsp	CAP.CHIP(1005.16V/0.1uF.X7R)_SAMSUNG		CCU1C104KCS	1	
C7123	nsp	CAP.CHIP(1005.16V/0.1uF.X7R)_SAMSUNG		CCU1C104KCS	1	
C7124	nsp	CAP.CHIP(1005.16V/0.1uF.X7R)_SAMSUNG		CCU1C104KCS	1	

REF No.	Part No.	Part Name	Remarks	Q'ty	New	Ver
C7492	nsp	CAP.CHIP(1005.16V/0.1uF.X7R) SAMSUNG		CCU1C104KCS	1	
C7493	nsp	CAP.CHIP(1005.16V/0.1uF.X7R) SAMSUNG		CCU1C104KCS	1	
C7494	nsp	CAP.CHIP(1005.16V/0.1uF.X7R) SAMSUNG		CCU1C104KCS	1	
C7495	nsp	CAP.CHIP(1005.16V/0.1uF.X7R) SAMSUNG		CCU1C104KCS	1	
C7496	nsp	CAP.CHIP(1005.16V/0.1uF.X7R) SAMSUNG		CCU1C104KCS	1	
C7497	nsp	CAP.CHIP(1005.16V/0.1uF.X7R) SAMSUNG		CCU1C104KCS	1	
C7498	nsp	CAP.CHIP(1005.16V/0.1uF.X7R) SAMSUNG		CCU1C104KCS	1	
C7499	nsp	CAP.CHIP(1005.16V/0.1uF.X7R) SAMSUNG		CCU1C104KCS	1	
C7500	nsp	CAP.CHIP(1005.16V/0.1uF.X7R) SAMSUNG		CCU1C104KCS	1	
C7501	nsp	CAP.CHIP(1005.16V/0.1uF.X7R) SAMSUNG		CCU1C104KCS	1	
C7502	nsp	CAP.CHIP(1005.16V/0.1uF.X7R) SAMSUNG		CCU1C104KCS	1	
C7503	nsp	CAP.CHIP(1608.50V/8pF.C0G) SAMSUNG		CCUS1H080DAS	1	
C7504	nsp	CAP.CHIP(1608.50V/8pF.C0G) SAMSUNG		CCUS1H080DAS	1	
C7505	nsp	CAP.CHIP(1005.16V/0.1uF.X7R) SAMSUNG		CCU1C104KCS	1	
C7506	nsp	CAP.CHIP(1608.50V/0.1uF.X7R) SAMSUNG		CCUS1H104KCS	1	
C7507	nsp	CAP.CHIP(1005.16V/0.1uF.X7R) SAMSUNG		CCU1C104KCS	1	
C7508	nsp	CAP.CHIP(1005.16V/0.1uF.X7R) SAMSUNG		CCU1C104KCS	1	
C7509	nsp	CAP.CHIP(1005.16V/0.1uF.X7R) SAMSUNG		CCU1C104KCS	1	
C7510	nsp	CAP.CHIP(1005.16V/0.1uF.X7R) SAMSUNG		CCU1C104KCS	1	
C7511	nsp	CAP.CHIP(1005.16V/0.1uF.X7R) SAMSUNG		CCU1C104KCS	1	
C7512	nsp	CAP.CHIP(1005.16V/0.1uF.X7R) SAMSUNG		CCU1C104KCS	1	
C7513	nsp	CAP.CHIP(1005.16V/0.1uF.X7R) SAMSUNG		CCU1C104KCS	1	
C7514	nsp	CAP.CHIP(1005.16V/0.1uF.X7R) SAMSUNG		CCU1C104KCS	1	
C7516	nsp	CAP.CHIP(1005.50V/220pF.C0G) SAMSUNG		CCU1H221JAS	1	
C7517	nsp	CAP.CHIP(1005.16V/0.1uF.X7R) SAMSUNG		CCU1C104KCS	1	
C7518	nsp	CAP.CHIP(1005.16V/0.1uF.X7R) SAMSUNG		CCU1C104KCS	1	
C7520	nsp	CAP.CHIP(1608.50V/0.01uF.X7R) SAMSUNG		CCUS1H103KCS	1	
C7521	nsp	CAP.CHIP(1608.50V/0.01uF.X7R) SAMSUNG		CCUS1H103KCS	1	
C7522	nsp	CAP.CHIP(1608.50V/0.01uF.X7R) SAMSUNG		CCUS1H103KCS	1	
C7523	nsp	CAP.CHIP(1608.50V/0.01uF.X7R) SAMSUNG		CCUS1H103KCS	1	
C7601	nsp	CAP.CHIP(1005.16V/0.1uF.X7R) SAMSUNG		CCU1C104KCS	1	
C7603	nsp	CAP.CHIP(1005.25V/0.01uF.X7R) SAMSUNG		CCU1E103KCS	1	
C7604	nsp	CAP.CHIP(1005.25V/0.01uF.X7R) SAMSUNG		CCU1E103KCS	1	
C7605	nsp	CAP.CHIP(1005.25V/0.01uF.X7R) SAMSUNG		CCU1E103KCS	1	
C7701	nsp	CAP.CHIP(1005.16V/0.1uF.X7R) SAMSUNG		CCU1C104KCS	1	
C7702	nsp	CAP.CHIP(1005.16V/0.1uF.X7R) SAMSUNG		CCU1C104KCS	1	
C7704	nsp	CAP.CHIP(1005.25V/0.01uF.X7R) SAMSUNG	S720, E3	CCU1E103KCS	1	
C7705	nsp	CAP.CHIP(1005.16V/0.1uF.X7R) SAMSUNG	S720, E3	CCU1C104KCS	1	
C7706	nsp	CAP.CHIP(1005.16V/0.1uF.X7R) SAMSUNG	S720, E3	CCU1C104KCS	1	
C7707	nsp	CAP.CHIP(1608.50V/4700pF.X7R) SAMSUNG		CCUS1H472KCS	1	
C7708	nsp	CAP.CHIP(1608.50V/4700pF.X7R) SAMSUNG		CCUS1H472KCS	1	
C7709	nsp	CAP.ELECT(60V/10uF)		CCEA1HH100T	1	
C7710	nsp	CAP.ELECT(60V/10uF)		CCEA1HH100T	1	
C7711	nsp	CAP.CHIP(1005.16V/0.1uF.X7R) SAMSUNG		CCU1C104KCS	1	
C7712	nsp	CAP.ELECT(60V/10uF)		CCEA1HH100T	1	
C7713	nsp	CAP.CHIP(1005.16V/0.1uF.X7R) SAMSUNG		CCU1C104KCS	1	
C7714	nsp	CAP.CHIP(1005.16V/0.1uF.X7R) SAMSUNG		CCU1C104KCS	1	
C7715	nsp	CAP.ELECT(60V/10uF)		CCEA1HH100T	1	
C7718	nsp	CAP.CHIP(2012.50V/4700pF.MURATAGRM21)		CCUMUC1H472JAM	1	
C7719	nsp	CAP.CHIP(3216.50V/0.068uF.MURATAGRM31)		CCUMUP1H683JAM	1	
C7720	nsp	CAP.CHIP(1005.16V/0.1uF.X7R) SAMSUNG		CCU1C104KCS	1	
C7721	nsp	CAP.ELECT(60V/10uF)		CCEA1HH100T	1	
C7722	nsp	CAP.CHIP(1005.16V/0.1uF.X7R) SAMSUNG		CCU1C104KCS	1	
C7723	nsp	CAP.ELECT(60V/10uF)		CCEA1HH100T	1	
C7724	nsp	CAP.CHIP(1005.16V/0.1uF.X7R) SAMSUNG		CCU1C104KCS	1	
C7725	nsp	CAP.ELECT(60V/100uF)		CCEA1HH101T	1	
C7726	nsp	CAP.CHIP(1005.50V/33pF.C0G) SAMSUNG		CCU1H330JAS	1	
C7727	nsp	CAP.CHIP(1005.50V/33pF.C0G) SAMSUNG		CCU1H330JAS	1	
C7751	nsp	CAP.CHIP(1005.16V/0.1uF.X7R) SAMSUNG		CCU1C104KCS	1	
C7752	nsp	CAP.CHIP(1005.16V/0.1uF.X7R) SAMSUNG		CCU1C104KCS	1	
C7753	nsp	CAP.CHIP(1005.16V/0.1uF.X7R) SAMSUNG		CCU1C104KCS	1	
C7754	nsp	CAP.CHIP(1005.16V/0.1uF.X7R) SAMSUNG		CCU1C104KCS	1	
C7755	nsp	CAP.CHIP(1005.16V/0.1uF.X7R) SAMSUNG		CCU1C104KCS	1	
C7756	nsp	CAP.CHIP(1005.16V/0.1uF.X7R) SAMSUNG		CCU1C104KCS	1	
C7757	nsp	CAP.CHIP(1005.16V/0.1uF.X7R) SAMSUNG		CCU1C104KCS	1	
C7758	nsp	CAP.CHIP(1005.16V/0.1uF.X7R) SAMSUNG		CCU1C104KCS	1	
C7801	nsp	CAP.CHIP(1005.16V/0.1uF.X7R) SAMSUNG		CCU1C104KCS	1	
C7802	nsp	CAP.CHIP(1005.16V/0.1uF.X7R) SAMSUNG		CCU1C104KCS	1	
C7803	nsp	CAP.CHIP(1005.16V/0.1uF.X7R) SAMSUNG		CCU1C104KCS	1	
C7804	nsp	CAP.CHIP(1005.16V/0.1uF.X7R) SAMSUNG		CCU1C104KCS	1	
C7805	nsp	CAP.CHIP(1005.50V/100pF.C0G) SAMSUNG		CCU1H101JAS	1	
C7806	nsp	CAP.ELECT(60V/100uF)		CCEA1HH101T	1	
C7807	nsp	CAP.ELECT(60V/10uF)		CCEA1HH100T	1	
C7808	nsp	CAP.ELECT(10V/47uF)		CCEA1AH470T	1	
C7809	nsp	CAP.CHIP(1005.16V/0.1uF.X7R) SAMSUNG		CCU1C104KCS	1	
C7810	nsp	CAP.CHIP(1005.16V/0.1uF.X7R) SAMSUNG		CCU1C104KCS	1	
C7811	nsp	CAP.CHIP(1005.16V/0.1uF.X7R) SAMSUNG		CCU1C104KCS	1	
C7812	nsp	CAP.CHIP(2012.6.3V/10uF.X5R) SAMSUNG		CCUC0J106KCS	1	
C7813	nsp	CAP.CHIP(1005.16V/0.1uF.X7R) SAMSUNG		CCU1C104KCS	1	
C7814	nsp	CAP.CHIP(1608.50V/12pF.C0G) SAMSUNG		CCUS1H120JAS	1	
C7815	nsp	CAP.CHIP(1608.50V/12pF.C0G) SAMSUNG		CCUS1H120JAS	1	
C7816	nsp	CAP.CHIP(1005.16V/0.1uF.X7R) SAMSUNG		CCU1C104KCS	1	
C7817	nsp	CAP.CHIP(1005.16V/0.1uF.X7R) SAMSUNG		CCU1C104KCS	1	
C7818	nsp	CAP.CHIP(1005.16V/0.1uF.X7R) SAMSUNG		CCU1C104KCS	1	
C7819	nsp	CAP.CHIP(1005.16V/0.1uF.X7R) SAMSUNG		CCU1C104KCS	1	
C7820	nsp	CAP.CHIP(1005.16V/0.1uF.X7R) SAMSUNG		CCU1C104KCS	1	
C7821	nsp	CAP.CHIP(1005.16V/0.1uF.X7R) SAMSUNG		CCU1C104KCS	1	
C7822	nsp	CAP.CHIP(1005.16V/0.1uF.X7R) SAMSUNG		CCU1C104KCS	1	
C7823	nsp	CAP.CHIP(1005.16V/0.1uF.X7R) SAMSUNG		CCU1C104KCS	1	
C7824	nsp	CAP.CHIP(1005.16V/0.1uF.X7R) SAMSUNG		CCU1C104KCS	1	
C7825	nsp	CAP.CHIP(1005.16V/0.1uF.X7R) SAMSUNG		CCU1C104KCS	1	
C7826	nsp	CAP.CHIP(1005.16V/0.1uF.X7R) SAMSUNG		CCU1C104KCS	1	
C7827	nsp	CAP.CHIP(1005.16V/0.1uF.X7R) SAMSUNG		CCU1C104KCS	1	
C7828	nsp	CAP.CHIP(1005.16V/0.1uF.X7R) SAMSUNG		CCU1C104KCS	1	
C7829	nsp	CAP.CHIP(1005.16V/0.1uF.X7R) SAMSUNG		CCU1C104KCS	1	
C7830	nsp	CAP.CHIP(1005.16V/0.1uF.X7R) SAMSUNG		CCU1C104KCS	1	
C7831	nsp	CAP.CHIP(1005.16V/0.1uF.X7R) SAMSUNG		CCU1C104KCS	1	
C7832	nsp	CAP.CHIP(1005.50V/1000pF.X7R) SAMSUNG		CCU1H102KCS	1	
C7833	nsp	CAP.CHIP(1005.16V/0.1uF.X7R) SAMSUNG		CCU1C104KCS	1	
C7834	nsp	CAP.CHIP(1005.16V/0.1uF.X7R) SAMSUNG		CCU1C104KCS	1	
C7835	nsp	CAP.CHIP(1005.50V/1000pF.X7R) SAMSUNG		CCU1H102KCS	1	
C7836	nsp	CAP.CHIP(1005.16V/0.1uF.X7R) SAMSUNG		CCU1C104KCS	1	
C7837	nsp	CAP.CHIP(1005.50V/1000pF.X7R) SAMSUNG		CCU1H102KCS	1	
C7838	nsp	CAP.CHIP(1005.16V/0.1uF.X7R) SAMSUNG		CCU1C104KCS	1	
C7839	nsp	CAP.CHIP(1005.50V/1000pF.X7R) SAMSUNG		CCU1H102KCS	1	
C7840	nsp	CAP.CHIP(1005.50V/1000pF.X7R) SAMSUNG		CCU1H102KCS	1	
C7841	nsp	CAP.CHIP(1005.16V/0.1uF.X7R) SAMSUNG		CCU1C104KCS	1	
C7842	nsp	CAP.CHIP(1005.50V/1000pF.X7R) SAMSUNG		CCU1H102KCS	1	
C7843	nsp	CAP.CHIP(1005.16V/0.1uF.X7R) SAMSUNG		CCU1C104KCS	1	
C7844	nsp	CAP.CHIP(1005.50V/1000pF.X7R) SAMSUNG		CCU1H102KCS	1	
C7845	nsp	CAP.CHIP(1005.16V/0.1uF.X7R) SAMSUNG		CCU1C104KCS	1	
C7846	nsp	CAP.CHIP(2012.6.3V/47uF.X5R) SAMSUNG		CCUC0J476KCS	1	
C7901	nsp	CAP.CHIP(1608.10V/1uF.X7R.X7S) SAMSUNG		CCUS1A105KCS	1	
C7902	nsp	CAP.ELECT(KR1.47uF/63V.8X11.5)		CCEA1JKR1470T	1	
C7903	nsp	CAP.CHIP(1005.16V/0.1uF.X7R) SAMSUNG		CCU1C104KCS	1	
C7904	nsp	CAP.ELECT(16V/220uF)		CCEA1CH221T	1	
C7905	nsp	CAP.CHIP(1608.10V/1uF.X7R.X7S) SAMSUNG		CCUS1A105KCS	1	

REF No.	Part No.	Part Name	Remarks	Q'ty	New	Ver
C8255	nsp	CAP.CHIP(1608.50V/0.1uF.X7R)_SAMSUNG		CCUS1H104KCS	1	
C8256	nsp	CAP.CHIP(1608.50V/0.1uF.X7R)_SAMSUNG		CCUS1H104KCS	1	
C8257	nsp	CAP.CHIP(1608.50V/0.1uF.X7R)_SAMSUNG		CCUS1H104KCS	1	
C8258	nsp	CAP.CHIP(1608.50V/0.1uF.X7R)_SAMSUNG		CCUS1H104KCS	1	
C8259	nsp	CAP.ELECT(50V/10uF)		CCEA1HH100T	1	
C8260	nsp	CAP.CHIP(1608.50V/0.1uF.X7R)_SAMSUNG		CCUS1H104KCS	1	
C8261	nsp	CAP.CHIP(1608.50V/0.1uF.X7R)_SAMSUNG		CCUS1H104KCS	1	
C8262	nsp	CAP.ELECT(50V/0.1uF)		CCEA1HH0R1T	1	
C8263	nsp	CAP.ELECT(50V/22uF)		CCEA1HH220T	1	
C8264	nsp	CAP.ELECT(50V/22uF)		CCEA1HH220T	1	
C8265	nsp	CAP.CHIP(1608.50V/330pF.C0G)_SAMSUNG		CCUS1H331JAS	1	
C8266	nsp	CAP.CHIP(1608.50V/0.1uF.X7R)_SAMSUNG		CCUS1H104KCS	1	
C8501	nsp	CAP.ELECT(50V/10uF)	E3	CCEA1HH100T	1	
C8502	nsp	CAP.ELECT(50V/10uF)	E3	CCEA1HH100T	1	
C8503	nsp	CAP.CHIP(1608.50V/0.1uF.X7R)_SAMSUNG	E3	CCUS1H104KCS	1	
C8504	nsp	CAP.CHIP(1608.50V/0.1uF.X7R)_SAMSUNG	E3	CCUS1H104KCS	1	
C8505	nsp	CAP.ELECT(50V/10uF)	E3	CCEA1HH100T	1	
C8506	nsp	CAP.ELECT(50V/10uF)	E3	CCEA1HH100T	1	
C8507	nsp	CAP.ELECT(50V/10uF)	E3	CCEA1HH100T	1	
C8508	nsp	CAP.ELECT(50V/10uF)	E3	CCEA1HH100T	1	
C8509	nsp	CAP.ELECT(50V/10uF)	E3	CCEA1HH100T	1	
C8510	nsp	CAP.ELECT(50V/10uF)	E3	CCEA1HH100T	1	
C8511	nsp	CAP.CHIP(1608.50V/39pF.C0G)_SAMSUNG	E3	CCUS1H390JAS	1	
C8512	nsp	CAP.CHIP(1608.50V/39pF.C0G)_SAMSUNG	E3	CCUS1H390JAS	1	
C8513	nsp	CAP.ELECT(50V/0.1uF)	E3	CCEA1HH0R1T	1	
C8514	nsp	CAP.ELECT(50V/22uF)	E3	CCEA1HH220T	1	
C8515	nsp	CAP.ELECT(50V/22uF)	E3	CCEA1HH220T	1	
C8516	nsp	CAP.ELECT(50V/22uF)	E3	CCEA1HH220T	1	
C8517	nsp	CAP.ELECT(50V/22uF)	E3	CCEA1HH220T	1	
C8518	nsp	CAP.CHIP(1608.50V/330pF.C0G)_SAMSUNG	E3	CCUS1H331JAS	1	
C8519	nsp	CAP.CHIP(1608.50V/330pF.C0G)_SAMSUNG	E3	CCUS1H331JAS	1	
C8520	nsp	CAP.CHIP(1608.50V/0.1uF.X7R)_SAMSUNG	E3	CCUS1H104KCS	1	
C8807	nsp	CAP.CHIP(1608.50V/22pF.C0G)_SAMSUNG		CCUS1H220JAS	1	
C8808	nsp	CAP.ELECT(50V/10uF)		CCEA1HH100T	1	
C8809	nsp	CAP.ELECT(50V/10uF)		CCEA1HH100T	1	
C8810	nsp	CAP.CHIP(1608.50V/0.1uF.X7R)_SAMSUNG		CCUS1H104KCS	1	
C8811	nsp	CAP.CHIP(1608.50V/0.1uF.X7R)_SAMSUNG		CCUS1H104KCS	1	
C8812	nsp	CAP.ELECT(50V/100uF)		CCEA1HH101T	1	
C8813	nsp	CAP.ELECT(50V/100uF)		CCEA1HH101T	1	
C8820	nsp	CAP.CHIP(1608.50V/0.1uF.X7R)_SAMSUNG		CCUS1H104KCS	1	
C8821	nsp	CAP.CHIP(1608.50V/0.1uF.X7R)_SAMSUNG		CCUS1H104KCS	1	
C8822	nsp	CAP.CHIP(1608.50V/0.1uF.X7R)_SAMSUNG		CCUS1H104KCS	1	
C8823	nsp	CAP.CHIP(1608.50V/0.1uF.X7R)_SAMSUNG		CCUS1H104KCS	1	
C8824	nsp	CAP.CHIP(1608.50V/0.1uF.X7R)_SAMSUNG		CCUS1H104KCS	1	
C8825	nsp	CAP.CHIP(1608.50V/0.1uF.X7R)_SAMSUNG		CCUS1H104KCS	1	
C8826	nsp	CAP.CHIP(1608.50V/0.1uF.X7R)_SAMSUNG		CCUS1H104KCS	1	
C8827	nsp	CAP.CHIP(1608.50V/0.1uF.X7R)_SAMSUNG		CCUS1H104KCS	1	
C8828	nsp	CAP.CHIP(1608.50V/0.1uF.X7R)_SAMSUNG		CCUS1H104KCS	1	
C8829	nsp	CAP.CHIP(1608.50V/0.1uF.X7R)_SAMSUNG		CCUS1H104KCS	1	
C8830	nsp	CAP.CHIP(1608.50V/0.1uF.X7R)_SAMSUNG		CCUS1H104KCS	1	
C8831	nsp	CAP.CHIP(1608.50V/0.1uF.X7R)_SAMSUNG		CCUS1H104KCS	1	
OTHER PARTS GROUP						
BK801	nsp	BRACKET,CY920		CMD1A924	1	
BN703	nsp	WIREASS'Y(1P,80MM,BLK,#22)		CWE5202080A	1	
CN701	nsp	WAFER,FFC(23PIN,1mmSTRAIGHT)		CJP23GA333ZR	1	
CN741	nsp	WAFER/STRAIGHT/2.5mm/6P		CJP06GA01ZY	1	
CN751	nsp	WAFER,FFC1.25mm,STRAIGHT		CJP27GA285ZN	1	
CN754	nsp	LOCK-WAFER/STRAIGHT/2MM PITCH/3PIN	E3	CJP03GI288ZY	1	
CN761	nsp	LOCK-WAFER/STRAIGHT/2MMPITCH/9PIN		CJP09GI288ZY	1	
CN762	nsp	LOCKINGTYPE,STRAIGHT8PWAFER		CJP08GI288ZY	1	
CN763	nsp	WAFER,FFC(4P-1mm,ANGLE)		CJP04GB113ZY	1	
CN801	nsp	WAFER,64pin(2x32x1.27mm)MALESMDTYPE		CJP64GA321ZP	1	
CN802	nsp	WAFER,64pin(2x32x1.27mm)MALESMDTYPE		CJP64GA321ZP	1	
CN803	nsp	WAFER,FFC(7PIN,1mmSTRAIGHT)		CJP07GA333ZR	1	
CN804	nsp	LOCK-WAFER/STRAIGHT/2MMPITCH/5PIN		CJP05GI288ZY	1	
CN821	nsp	PIN SOCKET(09P,1.25mm,ANGLE,B-TO-B)		CJP09HJ282Z	1	
CN822	nsp	PIN SOCKET(15P,1.25mm,ANGLE,B-TO-B)		CJP15HJ282Z	1	
CN823	nsp	LOCK-WAFER/STRAIGHT/2MMPITCH/5PIN		CJP05GI288ZY	1	
JK701	943643102920S	JACK,HDMI(TYPE-A,SMT-19P,WITHFLANGE)		CJJ9H021Z	1	
JK711	943643102920S	JACK,HDMI(TYPE-A,SMT-19P,WITHFLANGE)		CJJ9H021Z	1	
JK721	943643102920S	JACK,HDMI(TYPE-A,SMT-19P,WITHFLANGE)		CJJ9H021Z	1	
JK731	943643102920S	JACK,HDMI(TYPE-A,SMT-19P,WITHFLANGE)		CJJ9H021Z	1	
JK741	943643102920S	JACK,HDMI(TYPE-A,SMT-19P,WITHFLANGE)		CJJ9H021Z	1	
JK751	943643102920S	JACK,HDMI(TYPE-A,SMT-19P,WITHFLANGE)		CJJ9H021Z	1	
JK771	943643100170S	JACK,1P(ORG),SILVER	S720, E3	CJJ4M043Y	1	
JK772	943262100150S	MODULE,OPTICAL(RX16MHz)		CJSJSR1124	1	
JK773	943262100150S	MODULE,OPTICAL(RX16MHz)		CJSJSR1124	1	
JK801	943643102430S	JACK,RJ-45W/TRANSFORMER		CJJ9L029Z	1	
JK821	943643101570S	JACK,4P(W/R,W/R),SEPA-GND		CJJ4P048U	1	
JK822	943643102940S	JACK,RCA2P(B/B),SILVERVERTICAL		CJJ4N110Z	1	
JK851	943643010150S	JACK,2P(W/R),SEPA-GND,SILVER	E3	CJJ4N034U	1	
JK881	943643102370S	JACK,RCA3P(Y/Y),SILVER		CJJ4S052Z	1	
L7101	nsp	FERRITECHIPBEAD(2012/220R,CB05YTYH221)		CLZ9R018V	1	
L7103	nsp	FERRITECHIPBEAD(2012/220R,CB05YTYH221)		CLZ9R018V	1	
L7104	nsp	FERRITECHIPBEAD(2012/220R,CB05YTYH221)		CLZ9R018V	1	
L7105	nsp	FERRITECHIPBEAD(2012/220R,CB05YTYH221)		CLZ9R018V	1	
L7106	nsp	FERRITECHIPBEAD(2012/220R,CB05YTYH221)		CLZ9R018V	1	
L7108	nsp	FERRITECHIPBEAD(2012/220R,CB05YTYH221)		CLZ9R018V	1	
L7109	nsp	FERRITECHIPBEAD(1608/60R,CB03YTYH600)		CLZ9R005V	1	
L7110	nsp	FERRITECHIPBEAD(2012/220R,CB05YTYH221)		CLZ9R018V	1	
L7111	nsp	FERRITECHIPBEAD(2012/220R,CB05YTYH221)		CLZ9R018V	1	
L7201	nsp	FERRITECHIPBEAD(2012/220R,CB05YTYH221)		CLZ9R018V	1	
L7202	nsp	FERRITECHIPBEAD(2012/220R,CB05YTYH221)		CLZ9R018V	1	
L7204	nsp	FERRITECHIPBEAD(2012/220R,CB05YTYH221)		CLZ9R018V	1	
L7205	nsp	FERRITECHIPBEAD(2012/220R,CB05YTYH221)		CLZ9R018V	1	
L7206	nsp	FERRITECHIPBEAD(2012/220R,CB05YTYH221)		CLZ9R018V	1	
L7208	nsp	FERRITECHIPBEAD(2012/220R,CB05YTYH221)		CLZ9R018V	1	
L7209	nsp	FERRITECHIPBEAD(2012/220R,CB05YTYH221)		CLZ9R018V	1	
L7210	nsp	FERRITECHIPBEAD(2012/220R,CB05YTYH221)		CLZ9R018V	1	
L7301	nsp	FERRITECHIPBEAD(1608/60R,CB03YTYH600)		CLZ9R005V	1	
L7302	nsp	FERRITECHIPBEAD(1608/60R,CB03YTYH600)		CLZ9R005V	1	
L7303	nsp	FERRITECHIPBEAD(1608/60R,CB03YTYH600)		CLZ9R005V	1	
L7304	nsp	FERRITECHIPBEAD(1608/60R,CB03YTYH600)		CLZ9R005V	1	
L7305	nsp	FERRITECHIPBEAD(1608/60R,CB03YTYH600)		CLZ9R005V	1	
L7306	nsp	FERRITECHIPBEAD(1608/60R,CB03YTYH600)		CLZ9R005V	1	
L7307	nsp	FERRITECHIPBEAD(1608/60R,CB03YTYH600)		CLZ9R005V	1	
L7308	nsp	FERRITECHIPBEAD(1608/60R,CB03YTYH600)		CLZ9R005V	1	
L7401	nsp	FERRITECHIPBEAD(1608/60R,CB03YTYH600)		CLZ9R005V	1	
L7402	nsp	FERRITECHIPBEAD(1608/60R,CB03YTYH600)		CLZ9R005V	1	
L7403	nsp	FERRITECHIPBEAD(1608/60R,CB03YTYH600)		CLZ9R005V	1	
L7411	nsp	FERRITECHIPBEAD(1608/60R,CB03YTYH600)		CLZ9R005V	1	
L7413	nsp	FERRITECHIPBEAD(1608/60R,CB03YTYH600)		CLZ9R005V	1	
L7421	nsp	FERRITECHIPBEAD(1608/60R,CB03YTYH600)		CLZ9R005V	1	
L7424	nsp	FERRITECHIPBEAD(2012/220R,CB05YTYH221)		CLZ9R018V	1	
L7429	nsp	FERRITECHIPBEAD(1608/60R,CB03YTYH600)		CLZ9R005V	1	
L7430	nsp	RES.CHIP(1608/5%/0ohm)		CRJ10DJOROT	1	
L7431	nsp	FERRITECHIPBEAD(1608/60R,CB03YTYH600)		CLZ9R005V	1	

REF No.	Part No.	Part Name	Remarks	Q'ty	New	Ver
L7434	nsp	FERRITECHIPBEAD(2012/220R,CB05YTYH221)		CLZ9R018V	1	
L7441	nsp	FERRITECHIPBEAD(1608/60R,CB03YTYH600)		CLZ9R005V	1	
L7444	nsp	FERRITECHIPBEAD(2012/220R,CB05YTYH221)		CLZ9R018V	1	
L7451	nsp	FERRITECHIPBEAD(1608/60R,CB03YTYH600)		CLZ9R005V	1	
L7453	nsp	RES.CHIP(1608/5%/0ohm)		CRJ10DJOR0T	1	
L7471	nsp	FERRITECHIPBEAD(1608/60R,CB03YTYH600)		CLZ9R005V	1	
L7473	nsp	RES.CHIP(1608/5%/0ohm)		CRJ10DJOR0T	1	
L7483	nsp	FERRITECHIPBEAD(1608/60R,CB03YTYH600)		CLZ9R005V	1	
L7484	nsp	COIL,SMD5040,3.6uH		CLQ28E3R6NRH	1	*
L7485	nsp	COIL,SMD5040,3.6uH		CLQ28E3R6NRH	1	*
L7486	nsp	COIL,SMD(2.2uH,4.6A5040,50X40)		CLQ28E2R2NRH	1	*
L7487	nsp	COIL,SMD5040,3.6uH		CLQ28E3R6NRH	1	*
L7488	nsp	COIL,SMD(2.2uH,4.6A5040,50X40)		CLQ28E2R2NRH	1	*
L7490	nsp	COIL,SMD(2.2uH,4.6A5040,50X40)		CLQ28E2R2NRH	1	*
L7501	nsp	FERRITECHIPBEAD(1608/60R,CB03YTYH600)		CLZ9R005V	1	
L7502	nsp	FERRITECHIPBEAD(1608/60R,CB03YTYH600)		CLZ9R005V	1	
L7503	nsp	FERRITECHIPBEAD(1608/60R,CB03YTYH600)		CLZ9R005V	1	
L7504	nsp	FERRITECHIPBEAD(1608/60R,CB03YTYH600)		CLZ9R005V	1	
L7505	nsp	FERRITECHIPBEAD(1608/60R,CB03YTYH600)		CLZ9R005V	1	
L7506	nsp	FERRITECHIPBEAD(1608/60R,CB03YTYH600)		CLZ9R005V	1	
L7507	nsp	FERRITECHIPBEAD(1608/60R,CB03YTYH600)		CLZ9R005V	1	
L7508	nsp	FERRITECHIPBEAD(1608/60R,CB03YTYH600)		CLZ9R005V	1	
L7509	nsp	FERRITECHIPBEAD(1608/60R,CB03YTYH600)		CLZ9R005V	1	
L7510	nsp	FERRITECHIPBEAD(1608/60R,CB03YTYH600)		CLZ9R005V	1	
L7511	nsp	FERRITECHIPBEAD(1608/60R,CB03YTYH600)		CLZ9R005V	1	
L7512	nsp	FERRITECHIPBEAD(1608/60R,CB03YTYH600)		CLZ9R005V	1	
L7513	nsp	FERRITECHIPBEAD(1608/60R,CB03YTYH600)		CLZ9R005V	1	
L7514	nsp	FERRITECHIPBEAD(1608/60R,CB03YTYH600)		CLZ9R005V	1	
L7515	nsp	FERRITECHIPBEAD(1608/60R,CB03YTYH600)		CLZ9R005V	1	
L7516	nsp	FERRITECHIPBEAD(1608/60R,CB03YTYH600)		CLZ9R005V	1	
L7517	nsp	FERRITECHIPBEAD(1608/60R,CB03YTYH600)		CLZ9R005V	1	
L7518	nsp	FERRITECHIPBEAD(1608/60R,CB03YTYH600)		CLZ9R005V	1	
L7519	nsp	FERRITECHIPBEAD(1608/60R,CB03YTYH600)		CLZ9R005V	1	
L7520	nsp	FERRITECHIPBEAD(1608/60R,CB03YTYH600)		CLZ9R005V	1	
L7521	nsp	RES.CHIP(1608/5%/0ohm)		CRJ10DJOR0T	1	
L7522	nsp	FERRITECHIPBEAD(1608/60R,CB03YTYH600)		CLZ9R005V	1	
L7523	nsp	FERRITECHIPBEAD(1608/60R,CB03YTYH600)		CLZ9R005V	1	
L7524	nsp	FERRITECHIPBEAD(1608/60R,CB03YTYH600)		CLZ9R005V	1	
L7525	nsp	FERRITECHIPBEAD(1608/60R,CB03YTYH600)		CLZ9R005V	1	
L7526	nsp	FERRITECHIPBEAD(1608/60R,CB03YTYH600)		CLZ9R005V	1	
L7527	nsp	FERRITECHIPBEAD(1608/60R,CB03YTYH600)		CLZ9R005V	1	
L7528	nsp	FERRITECHIPBEAD(1608/60R,CB03YTYH600)	E3	CLZ9R005V	1	
L7529	nsp	FERRITECHIPBEAD(1608/60R,CB03YTYH600)	E3	CLZ9R005V	1	
L7530	nsp	FERRITECHIPBEAD(1608/60R,CB03YTYH600)	E3	CLZ9R005V	1	
L7601	nsp	FERRITECHIPBEAD(1608/60R,CB03YTYH600)		CLZ9R005V	1	
L7602	nsp	FERRITECHIPBEAD(1608/60R,CB03YTYH600)		CLZ9R005V	1	
L7603	nsp	FERRITECHIPBEAD(1608/60R,CB03YTYH600)		CLZ9R005V	1	
L7604	nsp	FERRITECHIPBEAD(1608/60R,CB03YTYH600)		CLZ9R005V	1	
L7605	nsp	FERRITECHIPBEAD(1608/60R,CB03YTYH600)		CLZ9R005V	1	
L7606	nsp	FERRITECHIPBEAD(1608/60R,CB03YTYH600)		CLZ9R005V	1	
L7607	nsp	FERRITECHIPBEAD(1608/60R,CB03YTYH600)		CLZ9R005V	1	
L7608	nsp	FERRITECHIPBEAD(1608/60R,CB03YTYH600)		CLZ9R005V	1	
L7609	nsp	FERRITECHIPBEAD(1608/60R,CB03YTYH600)		CLZ9R005V	1	
L7610	nsp	FERRITECHIPBEAD(1608/60R,CB03YTYH600)		CLZ9R005V	1	
L7611	nsp	FERRITECHIPBEAD(1608/60R,CB03YTYH600)		CLZ9R005V	1	
L7612	nsp	FERRITECHIPBEAD(1608/60R,CB03YTYH600)		CLZ9R005V	1	
L7613	nsp	FERRITECHIPBEAD(1608/60R,CB03YTYH600)		CLZ9R005V	1	
L7614	nsp	FERRITECHIPBEAD(1608/60R,CB03YTYH600)		CLZ9R005V	1	
L7615	nsp	FERRITECHIPBEAD(1608/60R,CB03YTYH600)		CLZ9R005V	1	
L7616	nsp	FERRITECHIPBEAD(1608/60R,CB03YTYH600)		CLZ9R005V	1	
L7617	nsp	FERRITECHIPBEAD(1608/60R,CB03YTYH600)		CLZ9R005V	1	
L7618	nsp	FERRITECHIPBEAD(1608/60R,CB03YTYH600)		CLZ9R005V	1	
L7801	nsp	FERRITECHIPBEAD(1608/60R,CB03YTYH600)		CLZ9R005V	1	
L7802	nsp	FERRITECHIPBEAD(1608/60R,CB03YTYH600)		CLZ9R005V	1	
L7803	nsp	FERRITECHIPBEAD(1608/60R,CB03YTYH600)		CLZ9R005V	1	
L8001	nsp	FERRITECHIPBEAD(1608/60R,CB03YTYH600)		CLZ9R005V	1	
L8002	nsp	FERRITECHIPBEAD(1608/60R,CB03YTYH600)		CLZ9R005V	1	
L8003	nsp	FERRITECHIPBEAD(1608/60R,CB03YTYH600)		CLZ9R005V	1	
L8004	nsp	FERRITECHIPBEAD(1608/60R,CB03YTYH600)		CLZ9R005V	1	
L8006	nsp	FERRITECHIPBEAD(2012/220R,CB05YTYH221)		CLZ9R018V	1	
L8007	nsp	COMMONMODEFILTER(2012.90ohm)		CLZ9T174Z	1	
L8008	nsp	COMMONMODEFILTER(2012.90ohm)		CLZ9T174Z	1	
L8201	nsp	FERRITECHIPBEAD(1608/60R,CB03YTYH600)		CLZ9R005V	1	
L8202	nsp	FERRITECHIPBEAD(1608/60R,CB03YTYH600)		CLZ9R005V	1	
X7101	943141101290S	X-TAL,SMD(27MHz/7pF,FA-238,3.2X2.5)		COX27000I070SP	1	
X7201	943141101290S	X-TAL,SMD(27MHz/7pF,FA-238,3.2X2.5)		COX27000I070SP	1	
X7301	943141101440S	X-TAL,SMD(28.63636MHz/7pF,FA-238,3.2X2.5)		COX28636I070SP	1	
X7501	943141101260S	X-TAL,SMD(12MHz/8pF,FA-238V,3.2X2.5)		COX12000I080SP	1	
X7801	943141101310S	X-TAL,SMD(24.576MHz/10pF,FA-238,3.2X2.5)		COX24576I100SP	1	

EXPLODED

※Parts indicated by "nsp" on this table cannot be supplied. Part indicated by "@" mark is not illustrated in the exploded view
 ※The parts listed below are only for maintenance. Therefore they might differ from the parts used in the unit in appearances or dimensions
 NOTE: The symbols in the column Remarks indicate the following destinations.
 E3 : U.S.A. & Canada model E2 : Europe model E1C : China model E1 : Asia model JP : Japan model
 BK : Black model SP : Premium Silver model

REF No.	Part No.	Part Name	Remarks	Q'ty	New	Ver
PCB GROUP						
P1	nsp	FRONT PCB		VOP12831C	1	*
P2	-	ENCODER&POWER PCB		VOP12831C	1	*
P3	-	HEADPHONE PCB		VOP12831C	1	*
P4	-	IPODUSB_MIC PCB		VOP12831C	1	*
P5	943639102590S	F-HDMI PCB		VOP12833B	1	*
P6	nsp	MAIN PCB		VOP12737H	1	
P6-P7	-	HDMI CABLE GUIDE PCB		VOP12737H	1	
P6-P8	-	FRONT CABLE GUIDE PCB		VOP12737H	1	
P6-P15	-	TUNER PCB		VOP12737H	1	
P6-P19	-	PHONE WIRE GUIDE PCB		VOP12737H	1	
P12	nsp	DIFF AMP PCB		VOP12618F	1	
P12-P9	-	BIAS TR PCB		VOP12618F	7	
P10	nsp	SMPS PCB		VOP12832C	1	*
P10-P11	-	REGULATOR PCB		VOP12832C	1	*
P13	9U6391026800S	DIGITAL PCB See PROCEDURE AFTER REPLACING THE PCB.	E3	VOP12834C	1	*
P13	9U6391026600S	DIGITAL PCB See PROCEDURE AFTER REPLACING THE PCB.	E2	VOP12834D	1	*
P13	9U6391026700S	DIGITAL PCB See PROCEDURE AFTER REPLACING THE PCB.	E1C, JP	VOP12834F	1	*
P13	9U6391026500S	DIGITAL PCB See PROCEDURE AFTER REPLACING THE PCB.	S720	VOP12834B	1	*
P14	963189101650S	MODULE_CY920-C (5GHZ) See PROCEDURE AFTER REPLACING THE U-COM, ETC.		8952230000010	1	*
! P16	943101102410D	TRANS,POWERAVR-S700W_X1100W/E3,(85.8X69)	S720, E3	CLT5U057ZU	1	
! P16	943101102420D	TRANS, POWER AVR-X1100W/E1/E2, (85.8X69)	E2	CLT5U057ZE	1	
! P16	943101102430D	TRANS, POWER AVR-X1100W/E1C, (85.8X69)	E1C	CLT5U057ZH	1	
! P16	943101102440D	TRANS, POWER AVR-X1100W/K, (85.8X69)	JP	CLT5U057ZJ	1	
! P18	943641500540S	AC INLET WIRE ASS'Y (2P,110MM)	E3, E2	CWZPM5003TW91AH	1	*
OTHER PARTS GROUP						
F1	943412100710D	KNOB,VOLUME		CBN1A263	1	
F2	943446100590D	PLATE,VOLUMEKNOB		CGX1A469	1	
F3	943412101070D	KNOB,SELECT		CBN1A274	1	
F4	943446100760D	PLATE,SELECTKNOB		CGX1A481	1	
F5	943402106070S	FRONT/SUB PANEL ASS'Y (X1300WE3)	E3	VGW1A552WA	1	*
F5	943402106080S	FRONT/SUB PANEL ASS'Y (X1300WE2/E1C)	E2, E1C	VGW1A553HA	1	*
F5	943402106100S	FRONT/SUB PANEL ASS'Y (X1300WK)	JP	VGW1A553JA	1	*
F5	943402106090S	FRONT/SUB PANEL ASS'Y (S720W)	S720	VGW1A553JA	1	*
F6	943416101290D	WINDOW,FL	E3, JP	VGU1A462R	1	
F6	943416101520D	WINDOW,FL	E2, E1C	VGU1A462S	1	
F6	943416101280D	WINDOW,FL	S720	VGU1A462Q	1	
F7	42141003400AD	BADGE,DENON	E3, JP	CGB1A275Z	1	
F7	42141002400AD	BADGE,DENON	S720, E2, E1C	CGB1A254Z-V1	1	
F9	943411101750D	BUTTON,POWER		CBT1A1167	1	
F10	943423100510D	INDICATOR,POWER		CGL1A299A36	1	
F11	943411101770D	BUTTON,10KEY		VBT2A1164	1	
F12	943411103220D	BUTTON,SOURCE	S720	VBT1A1195	1	
F13	943411103210D	BUTTON,NETWORK	S720	VBT1A1194	1	
F14	nsp	EARTH PLATE, HDMI		VMC1A431	1	
F15	nsp	EARTH PLATE, USB		VMC1A430	1	
F16	42131003300AD	BADGE,INCOMEND	E3	CGB1A276Z	1	
F17	nsp	CUSHION,HDMI		CHG1A622	1	
M1	nsp	CHASSIS,BOTTOM		VUA3A335	1	
M2	nsp	RUBBER		CHG1A113	1	
M3	nsp	LABEL,BOTTOM		VQB1A1243	1	
M4	943407100020D	FOOT		CKL1A190	4	
M5	nsp	CUSHIONFOOT		VHG2A289	4	
M6	nsp	HEATSINK,MAIN		VMY1A408	1	
M7	nsp	HOLDER,PCB		CHE170	2	
M8	nsp	SMPSBRACKET		CMD1A790	1	
M9	nsp	PANEL,REAR	E3	VKF1A480E	1	*
M9	nsp	PANEL,REAR	E2	VKF2A480D	1	*
M9	nsp	PANEL,REAR	E1C	VKF3A480C	1	*
M9	nsp	PANEL,REAR	JP	VKF3A480B	1	*
M9	nsp	PANEL,REAR	S720	VKF4A480F	1	*
M10	nsp	BUSHING,ACCORD	S720, E1C, JP	CHR1A028	1	
! @	90M-YC000850R	POWER CORD (CHINA CONNECTOR TYPE WHITE BANDING)	E1C	CJA2N047WA	1	
! @	943611501180S	POWER CORD (JAPAN CONNECTOR TYPE WHITE BANDING)	JP	VJA2J049YV01	1	*
! @	943611501190S	POWER CORD (USA CONNECTOR TYPE, WHITE BANDING)	S720	VJA2A159ZV01	1	*
M11	963419100930S	CLIP,WIFIANTENNA		CMH1A360	2	
M12	963419100910S	BUSH,WIFIANTENNA		CMH1A357	2	
M13	963419100920S	HOLDER,WIFIANTENNA		CMH1A358	2	
M14-1	963116100810S	ANTENNA,ROD wire 450mm		E600000230040S	1	
M14-2	963116100820S	ANTENNA,ROD wire 300mm		E600000230030S	1	
M15	943403100570D	CABINET, TOP		VKC1A215K117	1	
@	943606502480S	CARDCABLE(1.25mm,27P,170mm,Btype,105°C,SHIELD)		CWC5C4A27B170B10001	1	
@	943606502940S	CARDCABLE(1.0mm,23P,230mm,Btype,105°C,SHIELD)		CWC5F4A23A230B08001	1	*
@	nsp	LABEL,DTSXFRONT		CQB1A1438Z	1	
SCREW GROUP						
S1	nsp	SCREW		VTB3+6JR	14	
S2	nsp	SCREW		CTB3+6FR	9	
S3	nsp	SCREW		VTBD3+6FFZR	13	
S4	nsp	SCREW		VTB3+8JR	24	
S5	nsp	SCREW		VTB3+8JFZR	5	
S6	nsp	SCREW		VTBD3+8JFZR	21	
S7	nsp	SCREW		VTW3+8JR	11	
S8	nsp	SCREW		VTW3+12JR	2	
S9	nsp	SCREW		CTBD4+8JFZR	6	
S10	nsp	SCREW,TRANS		VHDR1A023R	4	
S11	nsp	SCREW,SPECIAL		VHDA0012R	3	
S12	nsp	SCREW,SPECIAL		VHD1A012ZR	14	
S13	nsp	SCREW		VTWS3+10GR	1	

PACKING

※Parts indicated by "nsp" on this table cannot be supplied. Part indicated by "@" mark is not illustrated in the exploded view
 ※The parts listed below are only for maintenance. Therefore they might differ from the parts used in the unit in appearances or dimensions
 NOTE: The symbols in the column Remarks indicate the following destinations.
 E3 : U.S.A. & Canada model E2 : Europe model E1C : China model E1 : Asia model JP : Japan model
 BK : Black model SP : Premium Silver model

REF No.	Part No.	Part Name	Remarks	Q'ty	New	Ver
1	nsp	POLYSHEET		1		
2	943611501140S	CORD , POWER (13A/125V,USA,INLET)	E3	1	*	
2	943611501150S	CORD , POWER (10A/250V,EUR,INLET)	E2	1	*	
3	943533102470D	PAD.SNOWTOP		1		
4	943533102480D	PAD.SNOWBOTTOM		1		
5	-	INSTRUCTIONMANUALASSY		1	*	
5-1	nsp	BAG.POLY	E3, E2, E1C, JP	1		
5-1	nsp	BAG.POLY(ENGLISH/FRANCH)	S720	1		
5-2	nsp	SHEET,NOTEONRADIO		1	*	
5-3	nsp	SHEET.SAFETY	S720, E3	1	*	
5-3	nsp	SHEET.SAFETY	E2	1	*	
5-3	nsp	SHEET.SAFETY	E1C	1	*	
5-3	nsp	SHEET.SAFETY	JP	1	*	
5-4	nsp	CARD.WARRANTY	S720, E3	1		
5-5	nsp	SHEET,INSERTION	E3	1		
5-6	943543104070S	LABEL.SPEAKER		1		
5-7	nsp	CARD FOR CHINA IDENTIFICATION	E1C	1		
5-8	54111136300AD	QUICK MANUAL(S720W)	S720	1	*	
5-9	nsp	SHEET.DTSXE3	S720	1		
5-10	nsp	SPOTIFYINSERTIONSHEET	S720	1		
5-11	nsp	SHEET.FIRMWAREUPDATE	S720	1	*	
5-12	943116100170D	FM1POLEANT(ULTYPE)		1		
5-13	963116100070S	ANT.AMLOOP(9.5uH/5T)		1		
5-14	nsp	China Tuner Isolator, SGLBF-6B	E1C	1		
6	-	MANUAL ASSY		1	*	
6-1	nsp	BAG.ZIPPERPOLY(A5)	E3, E2, E1C, JP	1		
6-2	35201043500AD	CDMANUALASSY	JP	1	*	
6-3	54111136400AD	QUICK MANUAL(X1300WE3)	E3	1	*	
6-3	54111136500AD	QUICK MANUAL(X1300WE2)	E2	1	*	
6-3	54111136700AD	QUICK MANUAL(X1300WE1C)	E1C	1	*	
6-3	54111136600AD	QUICK MANUAL(X1300WK)	JP	1	*	
6-4	nsp	SHEET.DTSXE3	E3	1		
6-4	nsp	SHEET.DTSXE2	E2	1		
6-4	nsp	SHEET.DTSXE1C	E1C	1		
6-4	nsp	SHEET.DTSXK(JP)	JP	1		
6-5	nsp	SPOTIFYINSERTIONSHEET	E3,E2	1		
6-6	nsp	SHEET.FIRMWAREUPDATE	E3	1	*	
7	30701016700AD	REMOCONASSY(RC-1189)AVR-X1100W/S700W		1		
8	nsp	BATTERY.AAA2PCSINPACK		2		
9	32401000800AD	MIC,AUDYSSEY		1		
10	42911002000AS	MIC STAND		1		
11	943531105780S	BOX.OUTCARTON	S720	1	*	
11	943531105770S	BOX.OUTCARTON	E3	1	*	
11	943531105810S	BOX.OUTCARTON	E2	1	*	
11	943531105800S	BOX.OUTCARTON	E1C	1	*	
11	943531105790S	BOX.OUTCARTON	JP	1	*	
12	nsp	LABEL.CONTROL		1		
13	nsp	CARD.GUARANTEEM	JP	1		
13	nsp	CARD.WARRANTY	E1C	1		
14	nsp	LABEL.RETURN(720E3)	S720	1	*	
14	nsp	LABEL.RETURN(1300E3)	E3	1	*	
15	nsp	LABEL.DTSXBOX		2		