

INTEGRATED NETWORK AV RECEIVER

AVR-X2400H

AVR-S930H



- For purposes of improvement, specifications and design are subject to change without notice.
- Please use this service manual with referring to the operating instructions without fail.
- Some illustrations using in this service manual are slightly different from the actual set.

Click here!

On-line service parts list

URL:<http://dmedia.dmglobal.com/Document/DocumentDetails/23152>

[Online Parts List](#) (P5 to P7)

On-line owner's manual

NA: <http://manuals.denon.com/AVRX2400H/NA/EN/index.php>

EU: <http://manuals.denon.com/AVRX2400H/EU/EN/index.php>

AP: <http://manuals.denon.com/AVRX2400H/AP/ZH/index.php>

NA: <http://manuals.denon.com/AVRS930H/NA/EN/index.php>

CAUTION IN SERVICING

ELECTRICAL

MECHANICAL

REPAIR INFORMATION

UPDATING

Please refer to the MODIFICATION NOTICE.

Confidential

CAUTION IN SERVICING

SAFETY PRECAUTIONS

NOTE FOR SCHEMATIC DIAGRAM

NOTE FOR PARTS LIST

INSTRUCTIONS FOR HANDLING SEMICONDUCTORS AND OPTICAL UNIT

Online Parts List

[Accessing the Parts List](#)

[Logging in to New SDI and Accessing the Parts List](#)

[Accessing the Part List from the Model Asset Screen](#)

[PRINTED CIRCUIT BOARDS Parts Table](#)

[Downloading the Parts List as an Excel File](#)

[Revision History](#)

[Searching Part Numbers or Ref. Numbers](#)

CAUTION IN SERVICING.

[Initializing This Unit](#) **AVR-X2400H**

[JIG FOR SERVICING](#)

[Initializing This Unit](#) **AVR-S930H**

[JIG FOR SERVICING](#)

SAFETY PRECAUTIONS

The following items should be checked for continued protection of the customer and the service technician.

Leakage current check

Before returning the set to the customer, be sure to carry out either (1) a leakage current check or (2) a line to chassis resistance check. If the leakage current exceeds 0.5 milliamps, or if the resistance from chassis to either side of the power cord is less than 460 kohms, the set is defective.

Be sure to test for leakage current with the AC plug in both polarities, in addition, when the set's power is in each state (on, off and standby mode), if applicable.

Ⓞ Make a safety check after servicing!

Check that all screws, parts and wires removed or disconnected when servicing have been put back in their original positions, check that no serviced parts have deteriorate the area around. Then make an insulation check on the external metal connectors and between the blades of the power plug, and otherwise check that safety is ensured.

(Insulation check procedure)

Unplug the power cord from the power outlet, disconnect the antenna, plugs, etc., and on the power. Using a 500V insulation resistance tester, check that the insulation resistance value between the inplug and the externally exposed metal parts (antenna terminal, headphones terminal, input terminal, etc.) is 1M Ω or greater. If it is less, the set must be inspected and repaired.

CAUTION

Please heed the following cautions and instructions during servicing and inspection.

Ⓞ Heed the cautions!

Cautions which are delicate in particular for servicing are labeled on the cabinets, the parts and the chassis, etc. Be sure to heed these cautions and the cautions described in the handling instructions.

Ⓞ Cautions concerning electric shock!

- (1) An AC voltage is impressed on this set, so if you touch internal metal parts when the set is energized, you may get an electric shock. Avoid getting an electric shock, by using an isolating transformer and wearing gloves when servicing while the set is energized, or by unplugging the power cord when replacing parts, for example.
- (2) There are high voltage parts inside. Handle with extra care when the set is energized.

Ⓞ Caution concerning disassembly and assembly!

Through great care is taken when parts were manufactured from sheet metal, there may be burrs on the edges of parts. The burrs could cause injury if fingers are moved across them in some rare cases. Wear gloves to protect your hands.

Ⓞ Use only designated parts!

The set's parts have specific safety properties (fire resistance, voltage resistance, etc.). Be sure to use parts which have the same properties for replacement. The burrs have the same properties. In particular, for the important safety parts that are indicated by the \triangle mark on schematic diagrams and parts lists, be sure to use the designated parts.

Ⓞ Be sure to mount parts and arrange the wires as they were originally placed!

For safety reasons, some parts use tapes, tubes or other insulating materials, and some parts are mounted away from the surface of printed circuit boards. Care is also taken with the positions of the wires by arranging them and using clamps to keep them away from heating and high voltage parts, so be sure to set everything back as it was originally placed.

CAUTION

Concerning important safety parts

Many of the electric and the structural parts used in the set have special safety properties. In most cases these properties are difficult to distinguish by sight, and the use of replacement parts with higher ratings (rated power and withstand voltage) does not necessarily guarantee that safety performance will be preserved. Parts with safety properties are indicated as shown below on the wiring diagrams and the parts list in this service manual. Be sure to replace them with the parts which have the designated part number.

- (1) Schematic diagrams Indicated by the \triangle mark.
- (2) Parts lists Indicated by the \triangle mark.

The use of parts other than the designated parts could cause electric shocks, fires or other dangerous situations.

NOTE FOR SCHEMATIC DIAGRAM

WARNING:

Parts indicated by the \triangle mark have critical characteristics. Use ONLY replacement parts recommended by the manufacturer.

CAUTION:

Before returning the set to the customer, be sure to carry out either (1) a leakage current check or (2) a line to chassis resistance check. If the leakage current exceeds 0.5 milliamps, or if the resistance from chassis to either side of the power cord is less than 460 kohms, the set is defective.

WARNING:

DO NOT return the set to the customer unless the problem is identified and remedied.

NOTICE:

ALL RESISTANCE VALUES IN OHM. k=1,000 OHM / M=1,000,000 OHM

ALL CAPACITANCE VALUES ARE EXPRESSED IN MICRO FARAD, UNLESS OTHERWISE INDICATED. P INDICATES MICRO-MICRO FARAD. N INDICATES NANO FARAD. EACH VOLTAGE AND CURRENT ARE MEASURED AT NO SIGNAL INPUT CONDITION. CIRCUIT AND PARTS ARE SUBJECT TO CHANGE WITHOUT PRIOR NOTICE.

NOTE FOR PARTS LIST

1. Parts indicated by "nsp" on this table cannot be supplied.
2. When ordering a part, make a clear distinction between "1" and "I" (i) to avoid mis-supplying.
3. A part ordered without specifying its part number can not be supplied.
4. Part indicated by "@" mark is not illustrated in the exploded view.

WARNING: Parts indicated by the \triangle mark have critical characteristics. Use ONLY replacement parts recommended by the manufacturer.

INSTRUCTIONS FOR HANDLING SEMICONDUCTORS AND OPTICAL UNIT

Electrostatic breakdown of the semi-conductors or optical pickup may occur due to a potential difference caused by electrostatic charge during unpacking or repair work.

1. Ground for Human Body

Be sure to wear a grounding band (1 M ohm) that is properly grounded to remove any static electricity that may be charged on the body.

2. Ground for Workbench

Be sure to place a conductive sheet or copper plate with proper grounding (1 M ohm) on the workbench or other surface, where the semi-conductors are to be placed. Because the static electricity charge on clothing will not escape through the body grounding band, be careful to avoid contacting semi-conductors with your clothing

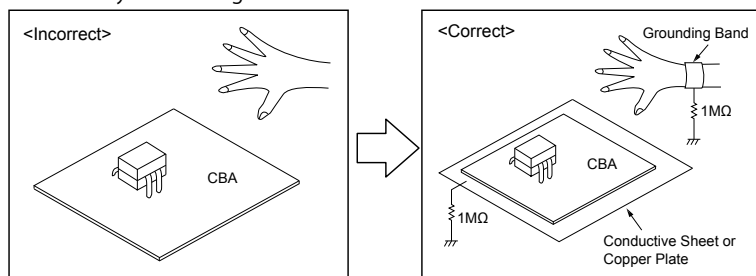

Accessing the Parts List

- (1) Click the URL link on the cover of the service manual.
Examples of display



NOTE: If the web browser does not open automatically, copy the URL and paste it into the address bar of the web browser and then press Enter.

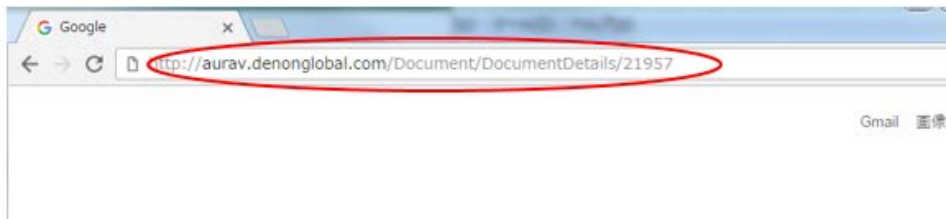

- (2) When the login screen is displayed, enter your username and password.
- (3) Enter the 5 letters shown as the blue CAPTCHA code as single-byte characters.
If the text is unclear, click "**Refresh**" to change the CAPTCHA code, and enter it again.



- (4) Press the "**Login**" button.

Logging in to New SDI and Accessing the Parts List

- (1) Access New SDI from the URL below.
<http://dmedia.dmglobal.com>
- (2) When the login screen is displayed, enter your username and password.
- (3) Enter the 5 letters shown as the blue CAPTCHA code as single-byte characters.
If the text is unclear, click "**Refresh**" to change the CAPTCHA code, and enter it again.



- (4) Press the "**Login**" button.
- (5) When the Home screen is displayed, click "**Advanced Search**".



- (6) Enter the following search conditions and click "**Search**".
Keyword : Model name Brand : brand name Asset Type : Part list

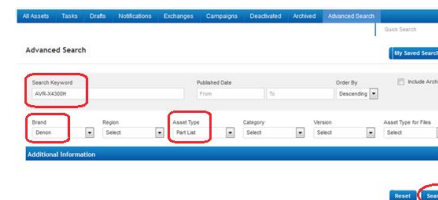

- (7) Click the model name when the search results are displayed.

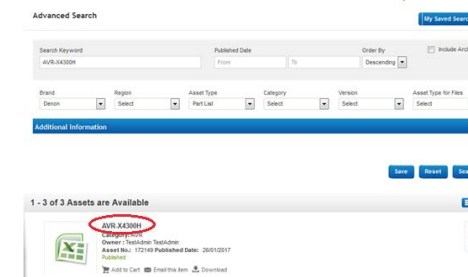

Accessing the Part List from the Model Asset Screen

- (1) Display Model Asset from New SDI.
- (2) Click the section displayed as ▼ Link to Part Lists under the model name.

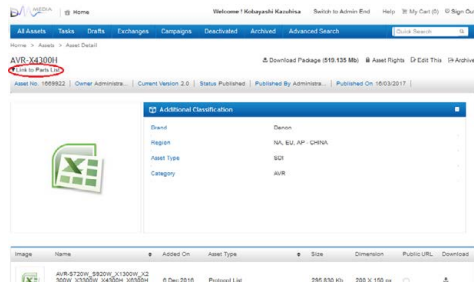

NOTE: If the ▼ Link to Parts List section is not displayed, download the parts table from the Asset list.

Downloading the Parts List as an Excel File

- (1) Displays the Parts List. Click the Download icon.

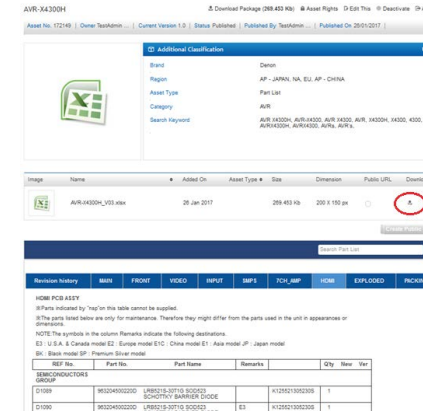

PRINTED CIRCUIT BOARDS Parts Table

- (1) Display the Parts List. Click the PCB name in the blue bar to display the parts list for the board.

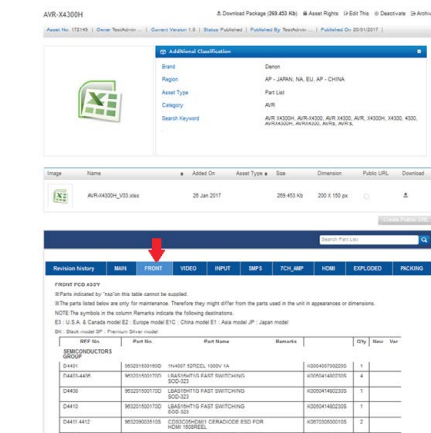

Left and right arrow icons are displayed if the circuit board name does not fit in the blue bar. Click these icons to display a different part of the name when necessary.

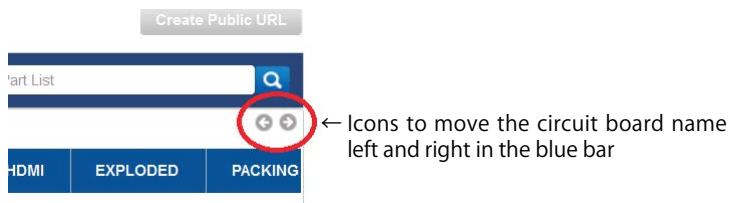

Revision History

- (1) Click "Revision history" in the blue bar.

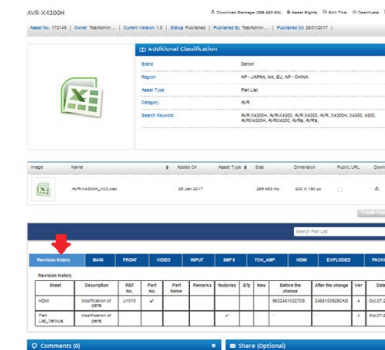

The following details are displayed.

- Sheet : Name of the changed sheet
- Description : Description of the changes
- Remarks : Destination, color information
- Factories : Factory number
- Ver : Version number after revision if changes were made to the parts list
- Date : Date of changes

Searching Part Numbers or Ref. Numbers

You can search a Parts List for part numbers or Ref. numbers.

- (1) Enter the part number or Ref. number in the search window of the Parts List, and press the search button.
- (2) The search results are displayed.
The name of the sheet in which the search part is used and the part's line are displayed.

S.No.	Sheet	REF No.	Part No.	Part Name	Remarks	Qty	New	Ver
1	MAIN	D4007	00279041905	15S133-0034-AJIAL LRC	K000013300405	1		
2	MAIN	D4016	00279041905	15S133-0034-AJIAL LRC	K000013300405	1		
3	MAIN	D4019	00279041905	15S133-0034-AJIAL LRC	K000013300405	1		
4	MAIN	D4031.4032	00279041905	15S133-0034-AJIAL LRC	K000013300405	2		
5	MAIN	D4037	00279041905	15S133-0034-AJIAL LRC	K000013300405	1		
6	INPUT	D4014.4012	00279041905	15S133-0034-AJIAL LRC	K000013300405	3		
7	SMP5	D4150	00279041905	15S133-0034-AJIAL LRC	K000013300405	1		

- (3) Next, click the "Sheet" section of the search results.

S.No.	Sheet	REF No.	Part No.	Part Name	Remarks	Qty	New	Ver
1	MAIN	D4007	00279041905	15S133-0034-AJIAL LRC	K000013300405	1		
2	MAIN	D4016	00279041905	15S133-0034-AJIAL LRC	K000013300405	1		
3	MAIN	D4019	00279041905	15S133-0034-AJIAL LRC	K000013300405	1		

- (4) The Board Part Table opens and the line on which the searched part number appears is highlighted.

REF No.	Part No.	Part Name	Remarks	Qty	New	Ver
SEMICONDUCTORS GROUP						
D4000-4004	9032015001700	LBAS15HTIG FAST SWITCHING 500-323	K0000414802305	5		
D4005	9032015001700	LBAS15HTIG FAST SWITCHING 500-323	K0000414802305	1		
D4008	9032030020000	DIODE BRIDGE D105B80 800V10A STRAIGHT TYPE	K0410080022025	1		
D4013	9032015001700	LBAS15HTIG FAST SWITCHING 500-323	K0000414802305	1		
D4014	9032015001500	1N4007 52REEL 1000V 1A	K0004007002205	1		
D4016	00279041905	15S133-0034-AJIAL LRC	K000013300405	1		

CAUTION IN SERVICING.

Initializing This Unit **AVR-X2400H**

Make sure to initialize this unit after replacing the microcomputer or any peripheral equipment, or the digital PCB.

1. Press the power button to turn off the power.
2. While holding down buttons "**ZONE2 SOURCE**" and "**DIMMER**" simultaneously, press the power button to turn on the power.
3. Release the buttons after confirming that the display flashes at 1-second intervals.
 - * The unit is initialized.Use network initialization mode to initialize the network related settings.

NOTE :

- If the unit fails to enter the service mode in step 3, repeat the procedure from step 1.
- Initializing the device restores the customized settings to the factory settings. Write down your settings in advance and reconfigure the settings after initialization.

AVR-X2400H

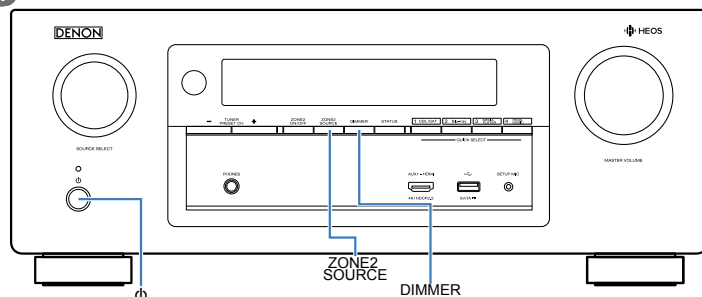

JIG FOR SERVICING

Use the following jigs (extension cable kit) when repairing the PCBs.
Order with your dealer for the jigs your dealer if necessary.

8U-110084S : EXTENSION UNIT KIT : 1 Set
(See [JIG FOR SERVICING](#))

Initializing This Unit **AVR-S930H**

Make sure to initialize this unit after replacing the microcomputer or any peripheral equipment, or the digital PCB.

1. Press the power button to turn off the power.
2. While holding down buttons "**TUNER PRESET CH +**" and "**TUNE -**" simultaneously, press the power button to turn on the power.
3. Release the buttons after confirming that the display flashes at 1-second intervals.
 - * The unit is initialized.Use network initialization mode to initialize the network related settings.

NOTE :

- If the unit fails to enter the service mode in step 3, repeat the procedure from step 1.
- Initializing the device restores the customized settings to the factory settings. Write down your settings in advance and reconfigure the settings after initialization.

AVR-S930H

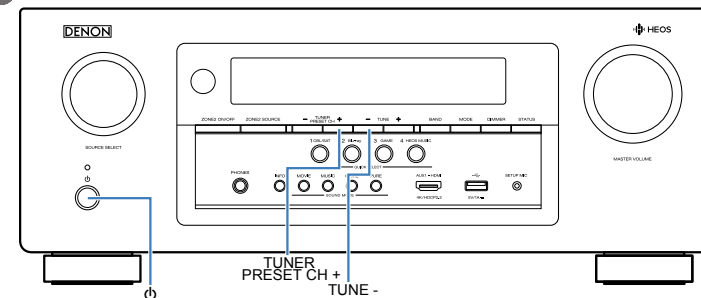

JIG FOR SERVICING

Use the following jigs (extension cable kit) when repairing the PCBs.
Order with your dealer for the jigs your dealer if necessary.

8U-110084S : EXTENSION UNIT KIT : 1 Set
(See [JIG FOR SERVICING](#))

ELECTRICAL

SCHEMATIC DIAGRAMS

SCH01_D.SUPPLY

SCH02_CPU

SCH03_DIGITAL CNT

SCH04_CPU LEVEL CHG

SCH05_HDMI SW1

SCH06_HDMI SW2

SCH07_TMDS SW

SCH08_HDMI TX

SCH09_ADV8003 DDR

SCH10_ADV8003

SCH11_DIR_A.PLD

SCH12_MAIN DAC

SCH13_DSP

SCH14_NET PHY

SCH15_INPUT 1

SCH16_INPUT 2

SCH17_VIDEO

SCH18_FRONT CNT

SCH19_RC-5

SCH20_AMP1

SCH21_AMP2

SCH22_SPK

SCH23_TUNER REG

SCH24_RS_CNT AUDIO IN

SCH25_FRONT

SCH26_RS232

SCH27_SMPS

SCH28_F-HDMI

PRINTED CIRCUIT BOARDS

DIGITAL, F HDMI

INPUT, VIDEO, FRONT CNT

AMP

MAIN, AUDIO IN, RS CNT, GUIDE L

FRONT, CNT, RS232, FUNCTION, HS TOP GUIDE, TOP

GUIDE

SMPS

LEVEL DIAGRAM

FRONT ch

CENTER, SURROUND, SURR.BCK ch

SUBWOOFER ch

ZONE2 ch

ZONE2(LEGO) ch

BLOCK DIAGRAM

ANALOG AUDIO DIAGRAM

DIGITAL AUDIO DIAGRAM

VIDEO DIAGRAM

POWER DIAGRAM

WIRING DIAGRAM

SEMICONDUCTORS

1. IC's

2. FL DISPLAY

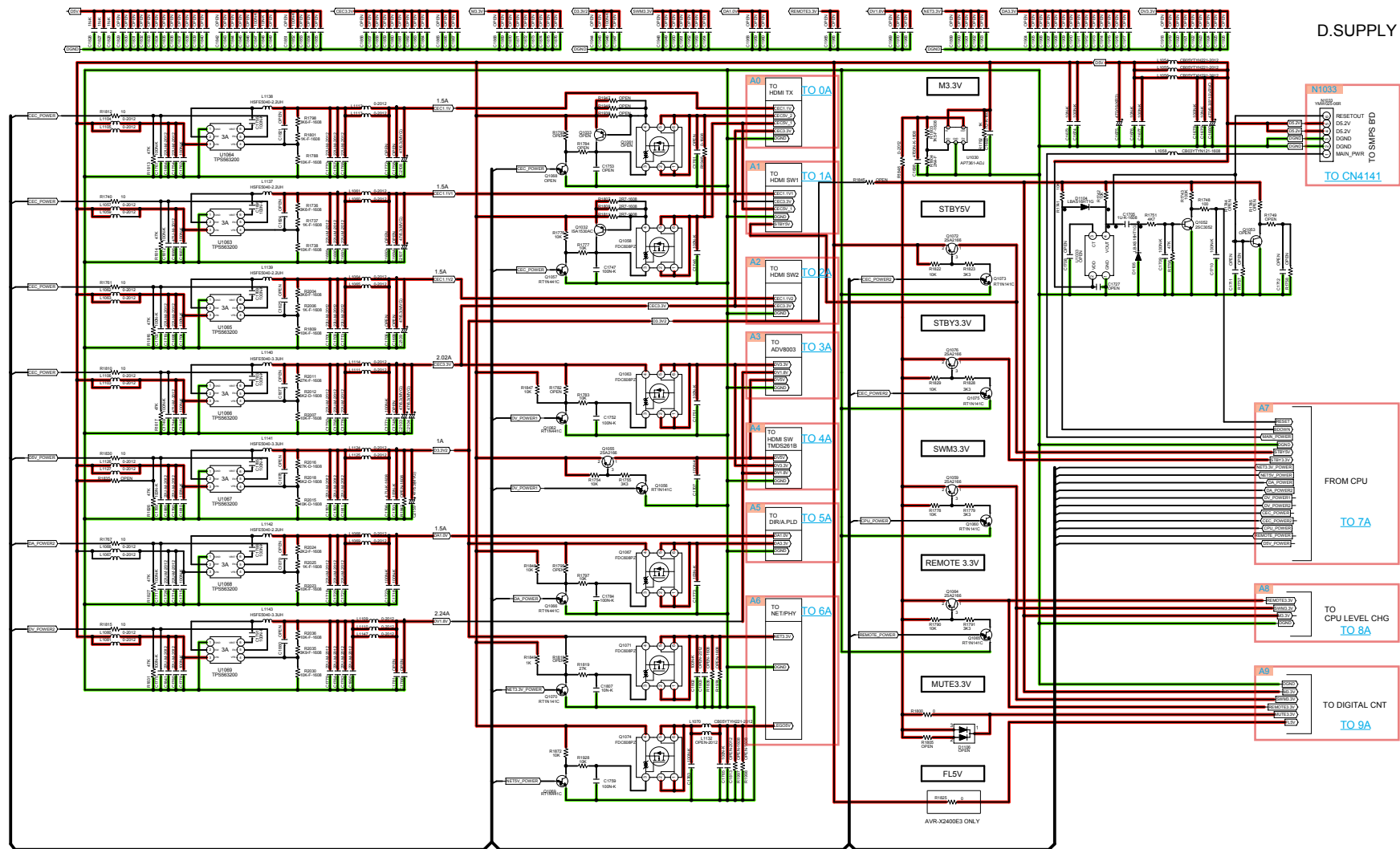

Caution in servicing

Electrical

Mechanical

Repair Information

Updating

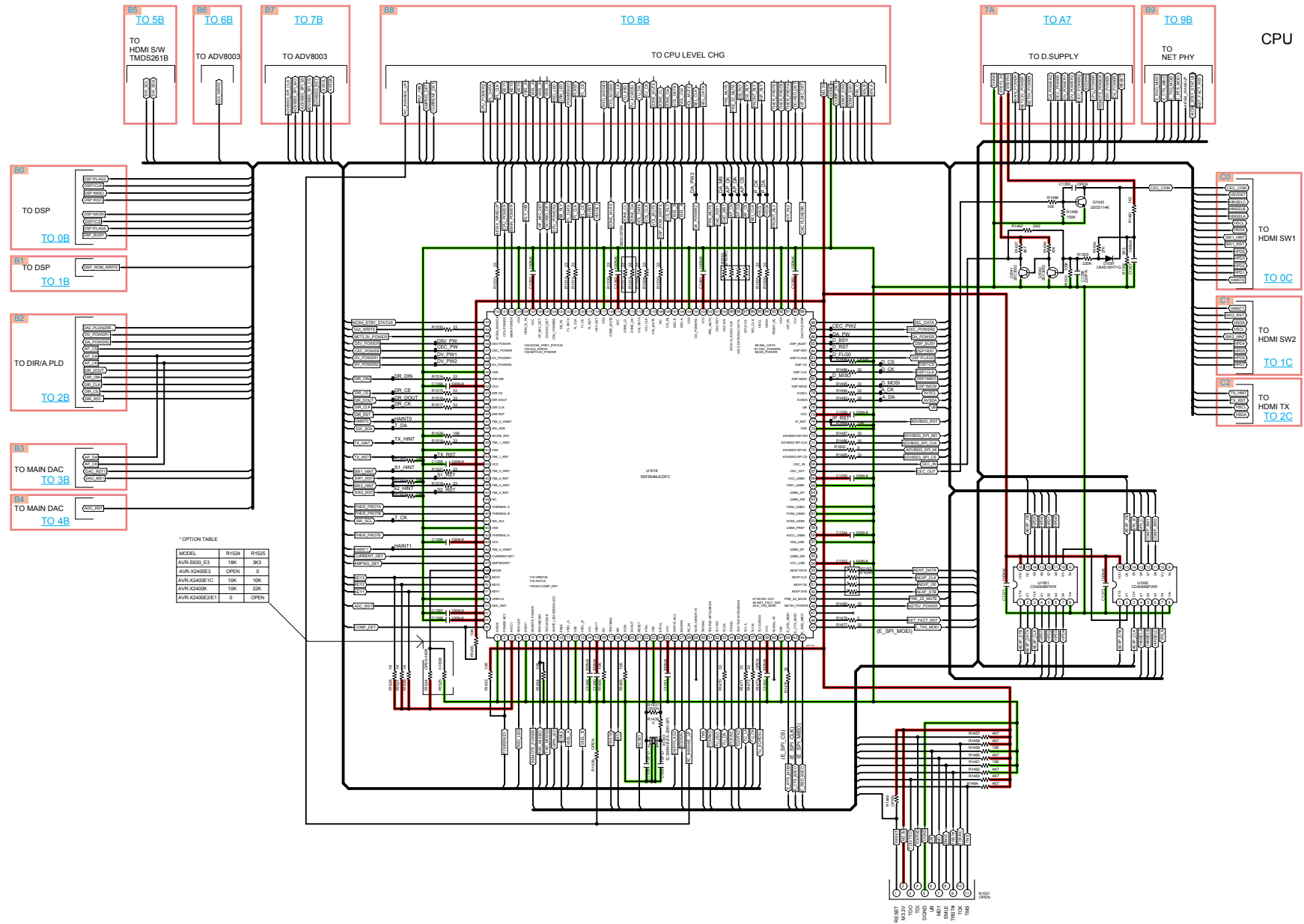

* OPTION TABLE

MODEL	R1524	R1521
AVR-X240E3	10K	30K
AVR-X240E3	OPEN	0
AVR-X240E1C	10K	10K
AVR-X240K	10K	22K
AVR-X240E2E1	0	OPEN

- GND LINE
- POWER+ LINE
- POWER- LINE
- TMSD SIGNAL
- ANALOG AUDIO
- DIGITAL AUDIO
- ANALOG VIDEO
- DIGITAL VIDEO
- HDMI
- STBY POWER

Caution in servicing

Electrical

Mechanical

Repair Information

Updating

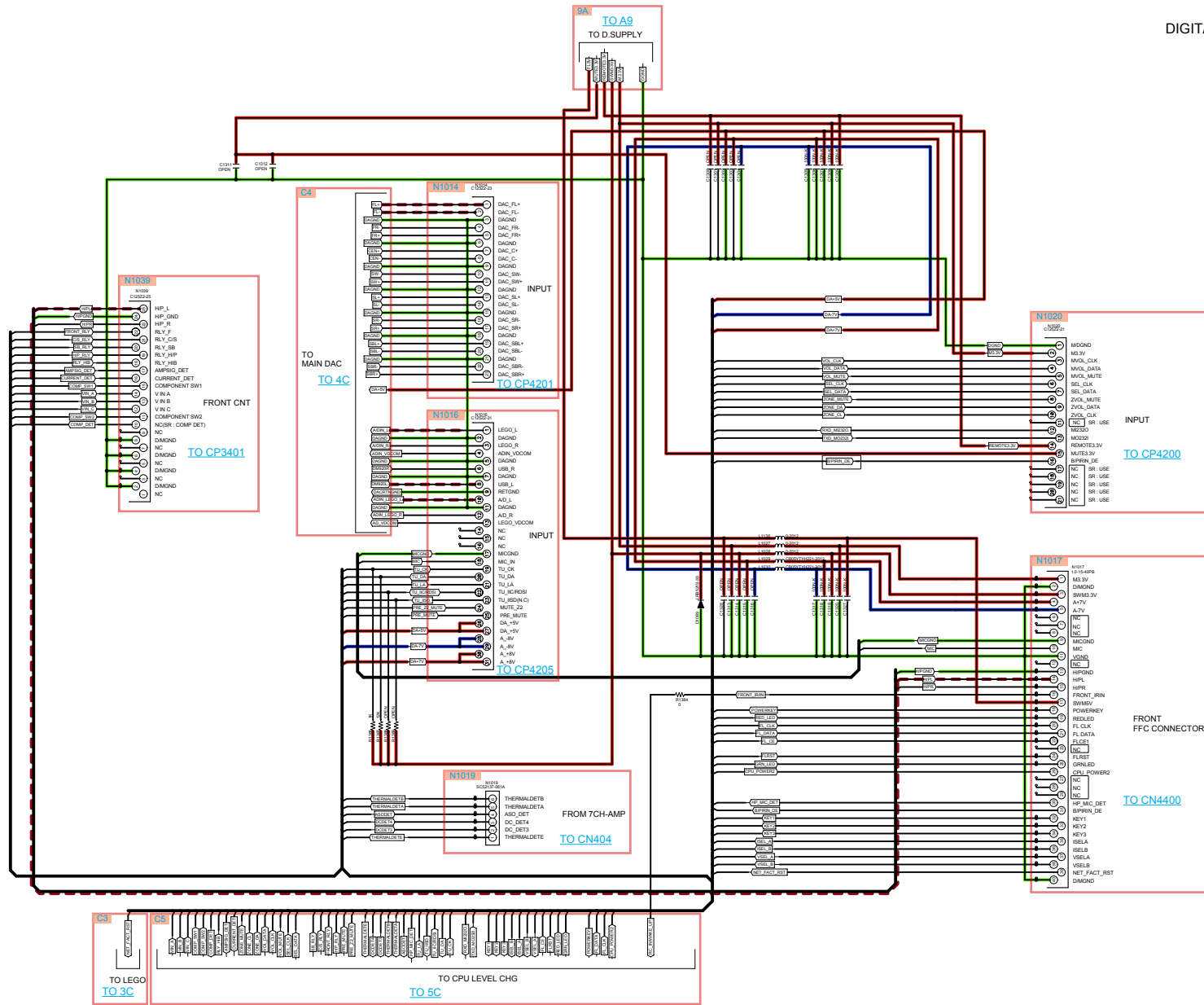

— GND LINE
 — POWER+ LINE
 — POWER- LINE
 — ANALOG AUDIO
 — DIGITAL AUDIO
 — TMSD SIGNAL
 — ANALOG VIDEO
 — DIGITAL VIDEO
 — HDMI
 — STBY POWER

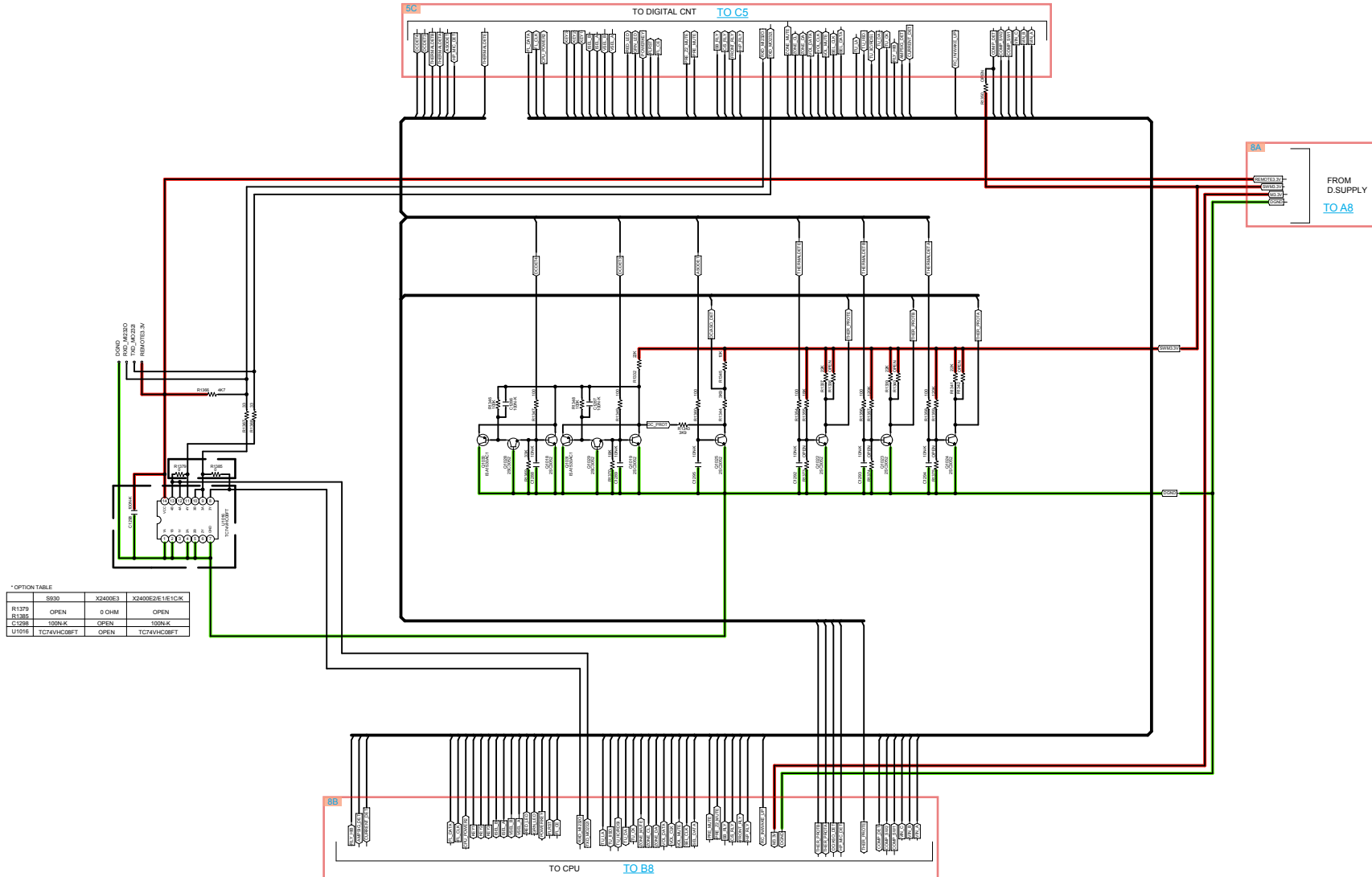

GND LINE POWER+ LINE POWER- LINE ANALOG AUDIO DIGITAL AUDIO TMDS SIGNAL ANALOG VIDEO DIGITAL VIDEO HDMI STBY POWER

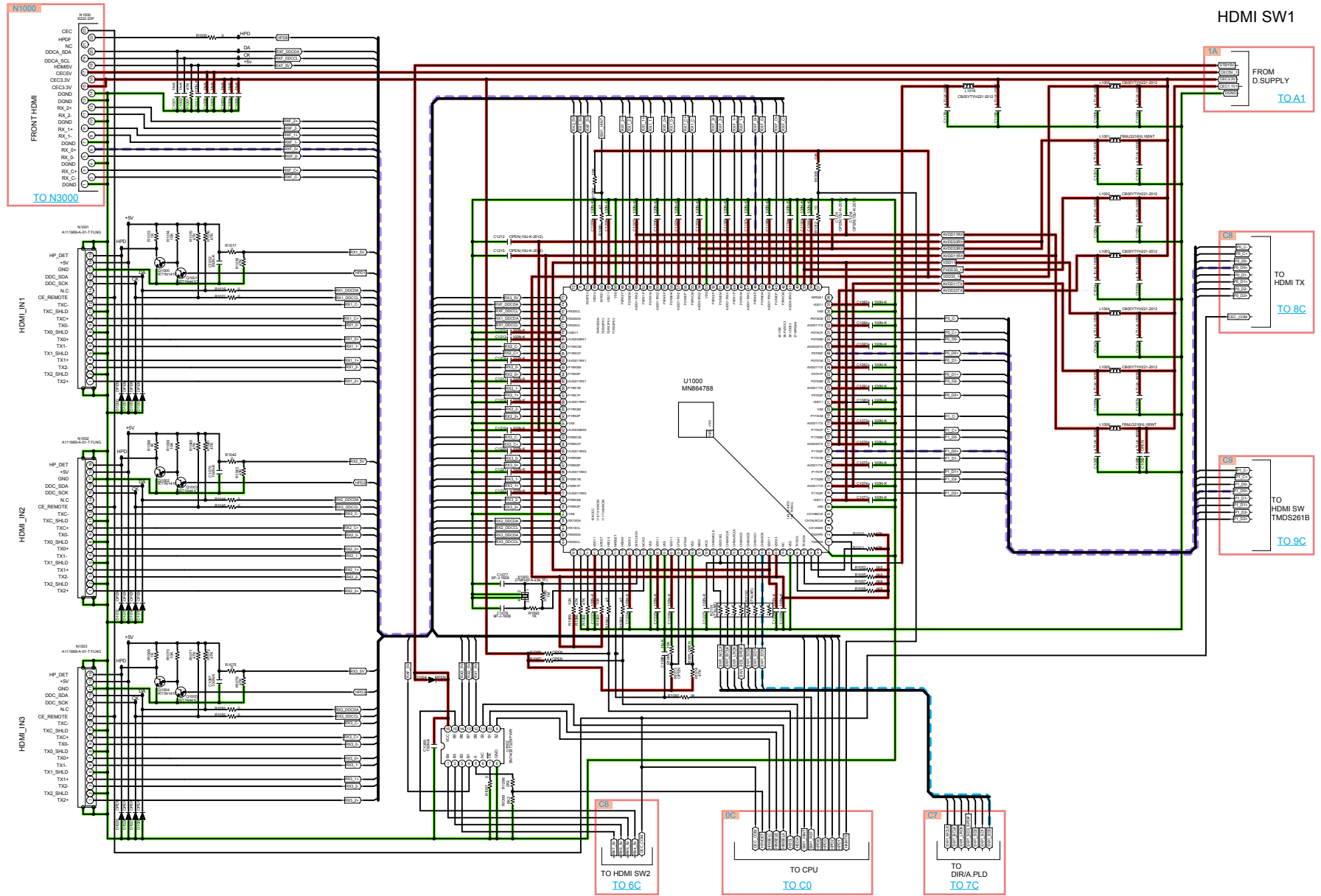

HDMI SW1

Caution in servicing

Electrical

Mechanical

Repair Information

Updating

— GND LINE
 — POWER+ LINE
 — POWER- LINE
 — ANALOG AUDIO
 — DIGITAL AUDIO
 — TMDS SIGNAL
 — ANALOG VIDEO
 — DIGITAL VIDEO
 - - - HDMI
 - - - STBY POWER

HDMI SW2

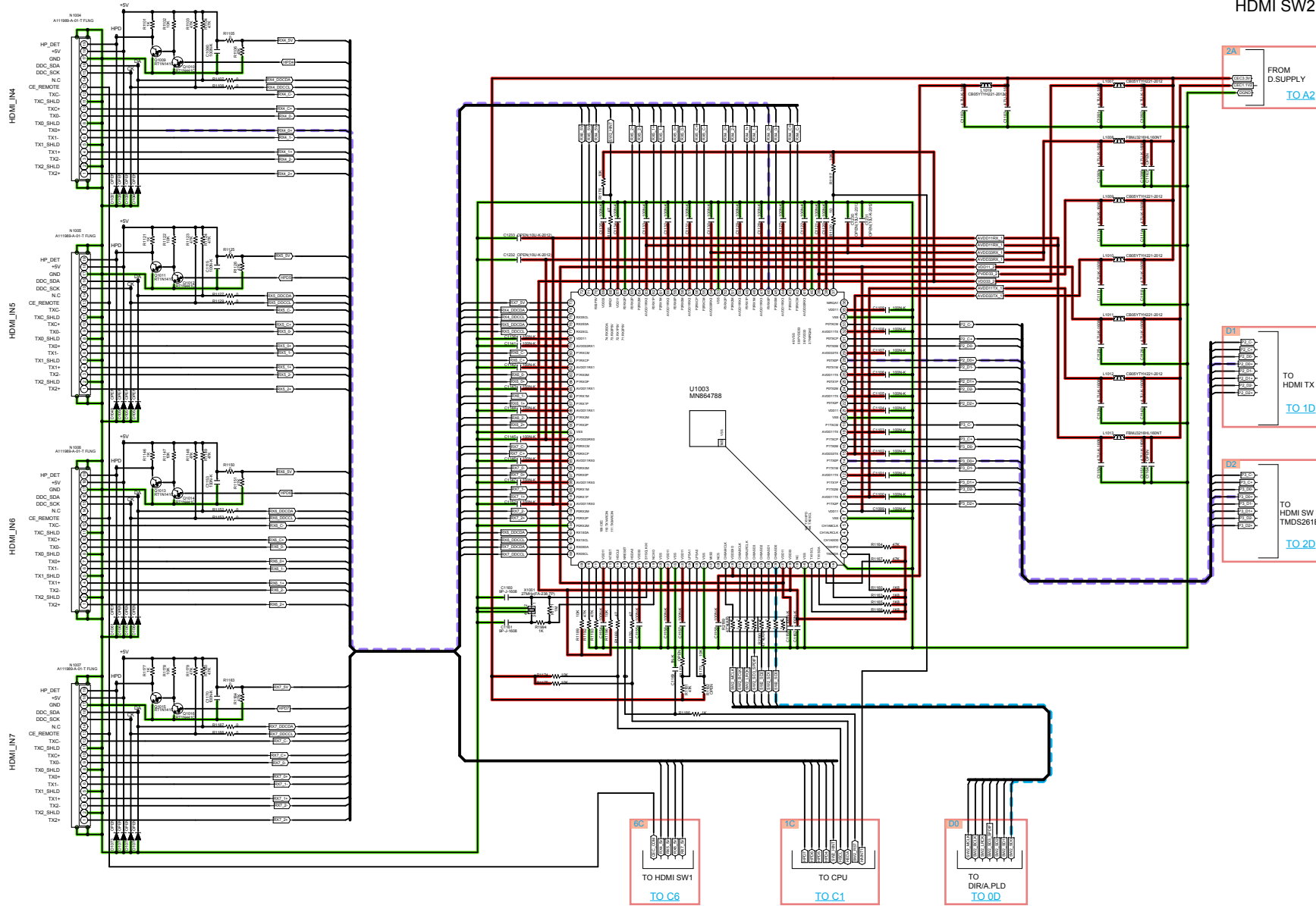

- GND LINE
- POWER+ LINE
- POWER- LINE
- ANALOG AUDIO
- DIGITAL AUDIO
- TMDS SIGNAL
- ANALOG VIDEO
- DIGITAL VIDEO
- HDMI
- STBY POWER

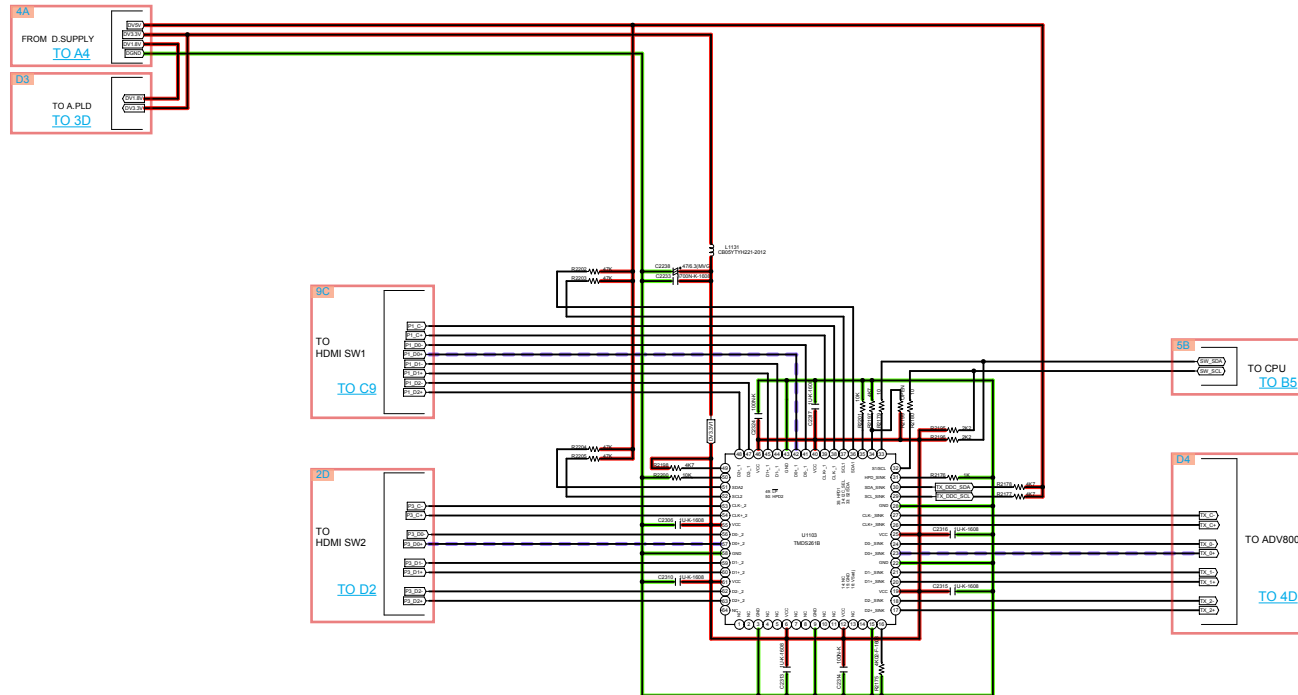

— GND LINE
 — POWER+ LINE
 — POWER- LINE
 — ANALOG AUDIO
 — DIGITAL AUDIO
 — TMDS SIGNAL
 — ANALOG VIDEO
 — DIGITAL VIDEO
 — HDMI
 — STBY POWER

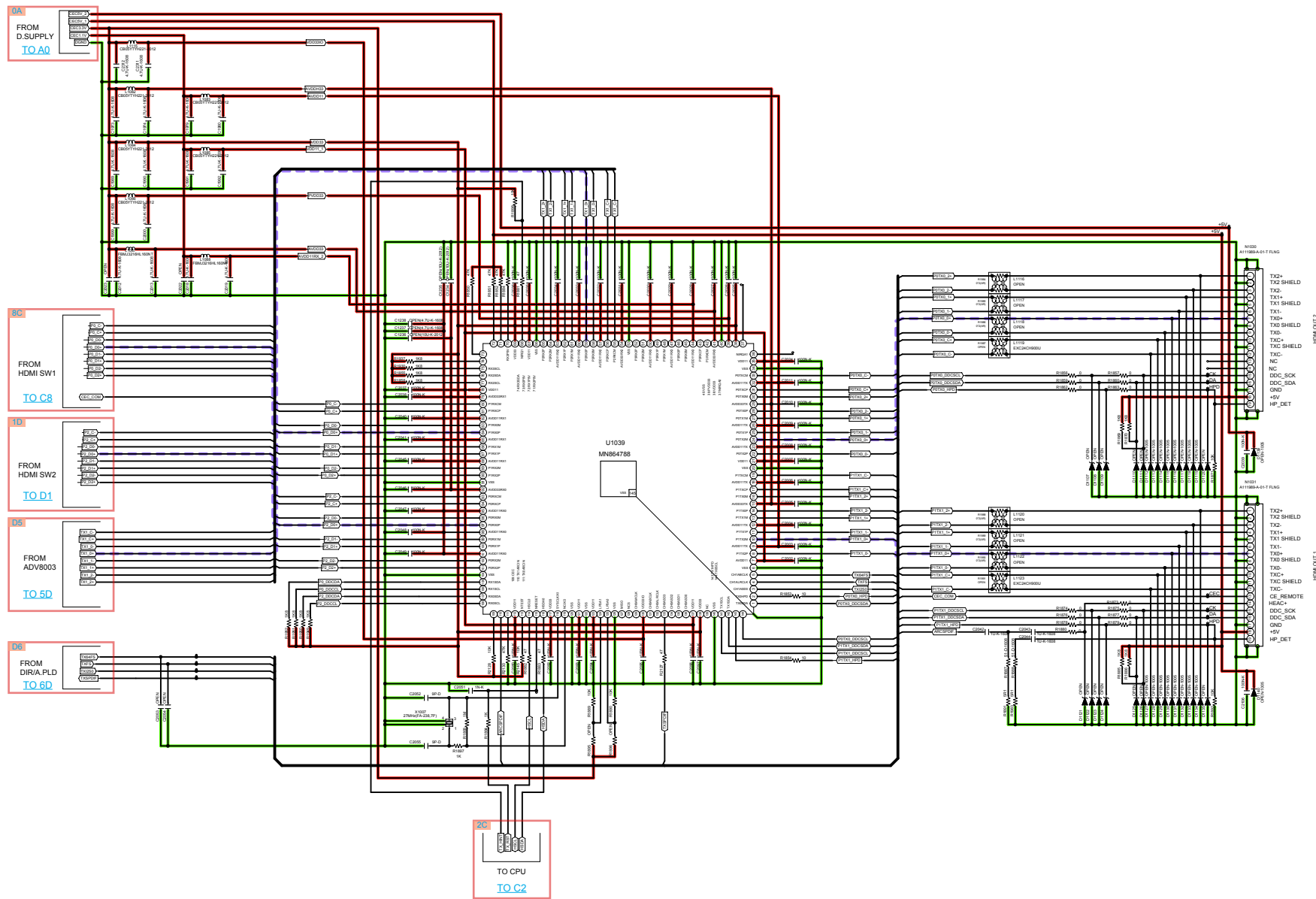

- GND LINE
- POWER+ LINE
- POWER- LINE
- ANALOG AUDIO
- DIGITAL AUDIO
- TMDS SIGNAL
- ANALOG VIDEO
- DIGITAL VIDEO
- HDMI
- STBY POWER

Caution in Servicing
 Electrical
 Mechanical
 Repair Information
 Updating

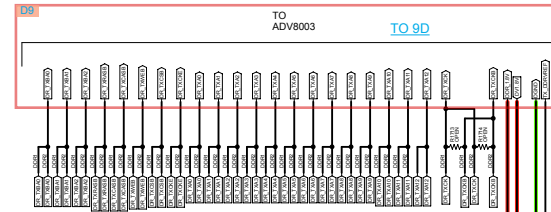
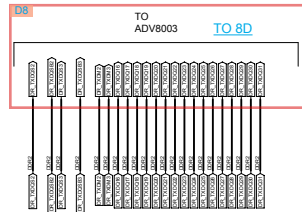
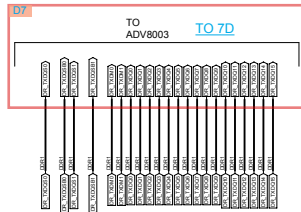

	1	2	3	U1029	A301 (S04K008F-8E(30Pin))	7	8	9
A	DDR1_1V				DDR1_1V029			DDR1_1V
B	DR_LVDS014	DDR0	DR_LVDS014		DR_LVDS014	DDR0		DR_LVDS014
C	DDR1_1V	DR_LVDS029	DDR1_1V		DDR1_1V	DR_LVDS029	DDR1_1V	
D	DR_LVDS012	DDR0	DR_LVDS011		DR_LVDS012	DDR0		DR_LVDS012
E	DDR1_1V				DR_LVDS029	DDR1_1V		DDR1_1V
F	DR_LVDS008	DDR0	DR_LVDS016		DR_LVDS007	DDR0		DR_LVDS007
G	DDR1_1V	DR_LVDS001	DDR1_1V		DDR1_1V	DR_LVDS001	DDR1_1V	
H	DR_LVDS004	DDR0	DR_LVDS003		DR_LVDS004	DDR0		DR_LVDS004
J	DDR1_1V	TX_CONVERT	DDR0		DR_LVDS004	DDR1_1V		DDR1_1V
K		DR_LVDS018	DR_LVDS013		DR_LVDS018	DR_LVDS013		DR_LVDS018
L	DR_LVDS012	DR_LVDS011			DR_LVDS012	DR_LVDS011		DR_LVDS012
M	DR_LVDS010	DR_LVDS011			DR_LVDS010	DR_LVDS011		DR_LVDS010
N	DDR0	DR_LVDS012	DR_LVDS013		DR_LVDS012	DR_LVDS013		DDR0
O		DR_LVDS012	DR_LVDS013		DR_LVDS012	DR_LVDS013		DR_LVDS012
P	DR_LVDS012	DR_LVDS013			DR_LVDS012	DR_LVDS013		DR_LVDS012
Q	DR_LVDS012	DR_LVDS013			DR_LVDS012	DR_LVDS013		DR_LVDS012
R	DDR1_1V	DR_LVDS012	DR_LVDS013		DR_LVDS012	DR_LVDS013		DDR1_1V

	1	2	3	U1029	A301 (S04K008F-8E(30Pin))	7	8	9
A	DDR1_1V				DDR1_1V029			DDR1_1V
B	DR_LVDS014	DDR0	DR_LVDS014		DR_LVDS014	DDR0		DR_LVDS014
C	DDR1_1V	DR_LVDS029	DDR1_1V		DDR1_1V	DR_LVDS029	DDR1_1V	
D	DR_LVDS012	DDR0	DR_LVDS011		DR_LVDS012	DDR0		DR_LVDS012
E	DDR1_1V				DR_LVDS029	DDR1_1V		DDR1_1V
F	DR_LVDS008	DDR0	DR_LVDS016		DR_LVDS007	DDR0		DR_LVDS007
G	DDR1_1V	DR_LVDS001	DDR1_1V		DDR1_1V	DR_LVDS001	DDR1_1V	
H	DR_LVDS004	DDR0	DR_LVDS003		DR_LVDS004	DDR0		DR_LVDS004
J	DDR1_1V	TX_CONVERT	DDR0		DR_LVDS004	DDR1_1V		DDR1_1V
K		DR_LVDS018	DR_LVDS013		DR_LVDS018	DR_LVDS013		DR_LVDS018
L	DR_LVDS012	DR_LVDS011			DR_LVDS012	DR_LVDS011		DR_LVDS012
M	DR_LVDS010	DR_LVDS011			DR_LVDS010	DR_LVDS011		DR_LVDS010
N	DDR0	DR_LVDS012	DR_LVDS013		DR_LVDS012	DR_LVDS013		DDR0
O		DR_LVDS012	DR_LVDS013		DR_LVDS012	DR_LVDS013		DR_LVDS012
P	DR_LVDS012	DR_LVDS013			DR_LVDS012	DR_LVDS013		DR_LVDS012
Q	DR_LVDS012	DR_LVDS013			DR_LVDS012	DR_LVDS013		DR_LVDS012
R	DDR1_1V	DR_LVDS012	DR_LVDS013		DR_LVDS012	DR_LVDS013		DDR1_1V

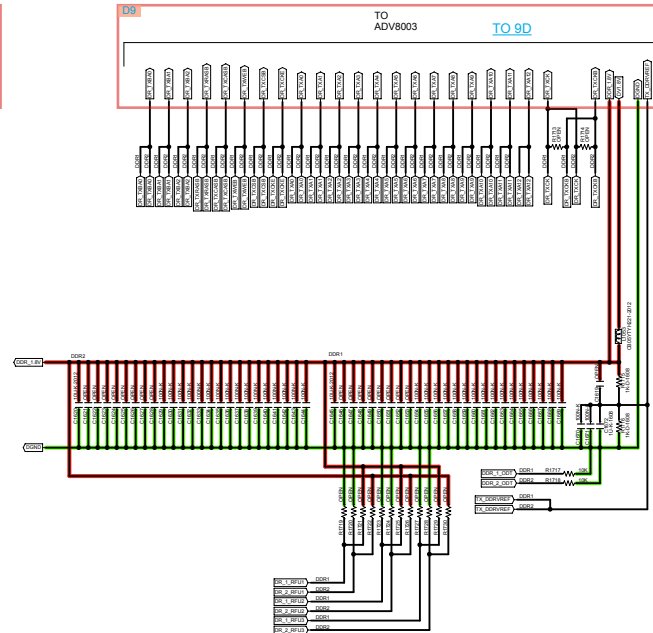

GND LINE POWER+ LINE POWER- LINE ANALOG AUDIO DIGITAL AUDIO TMD5 SIGNAL ANALOG VIDEO DIGITAL VIDEO HDMI STBY POWER

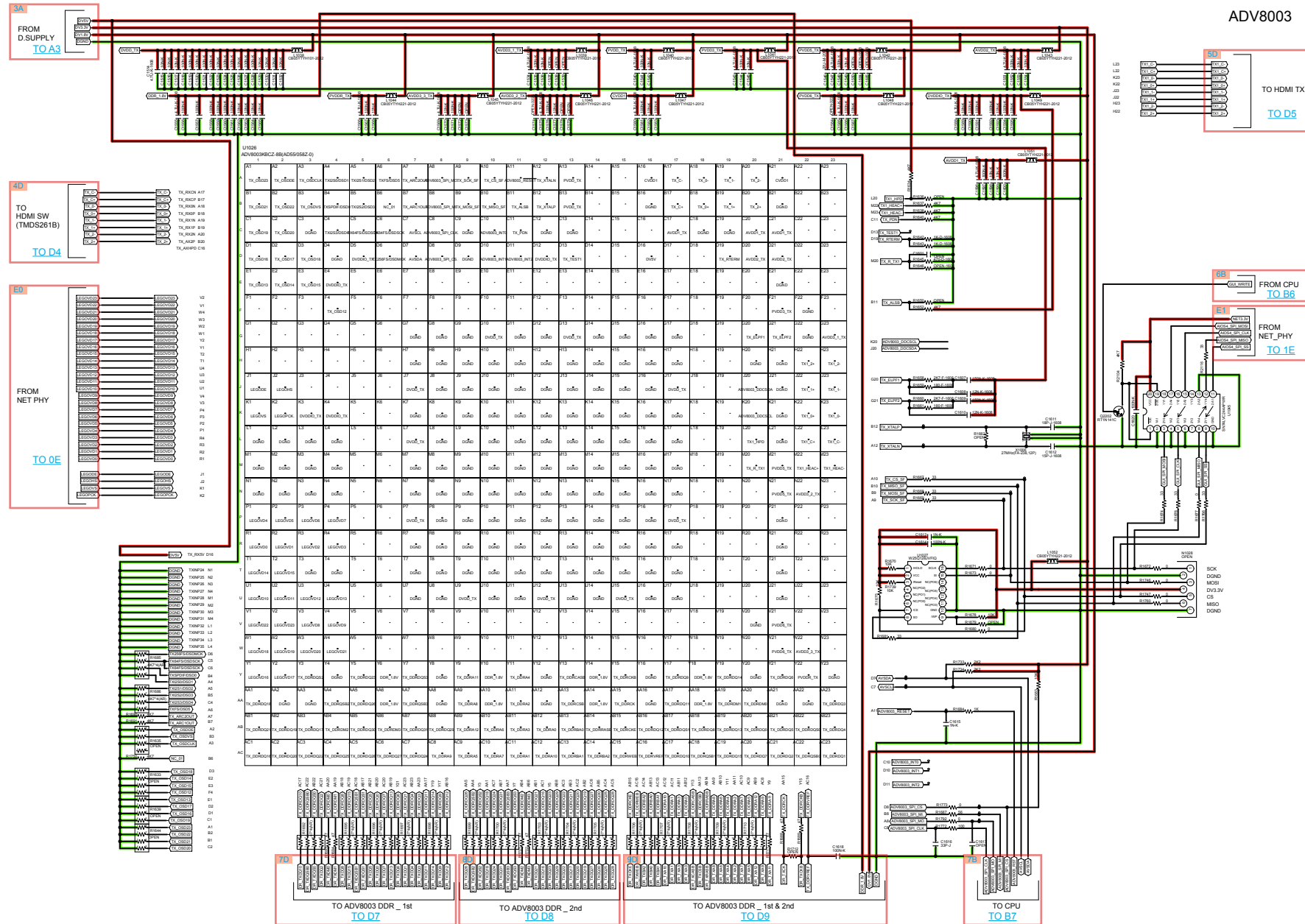

GND LINE POWER+ LINE POWER- LINE ANALOG AUDIO DIGITAL AUDIO TMSD SIGNAL ANALOG VIDEO DIGITAL VIDEO HDMI STBY POWER

Caution in servicing

Electrical

Mechanical

Repair Information

Updating

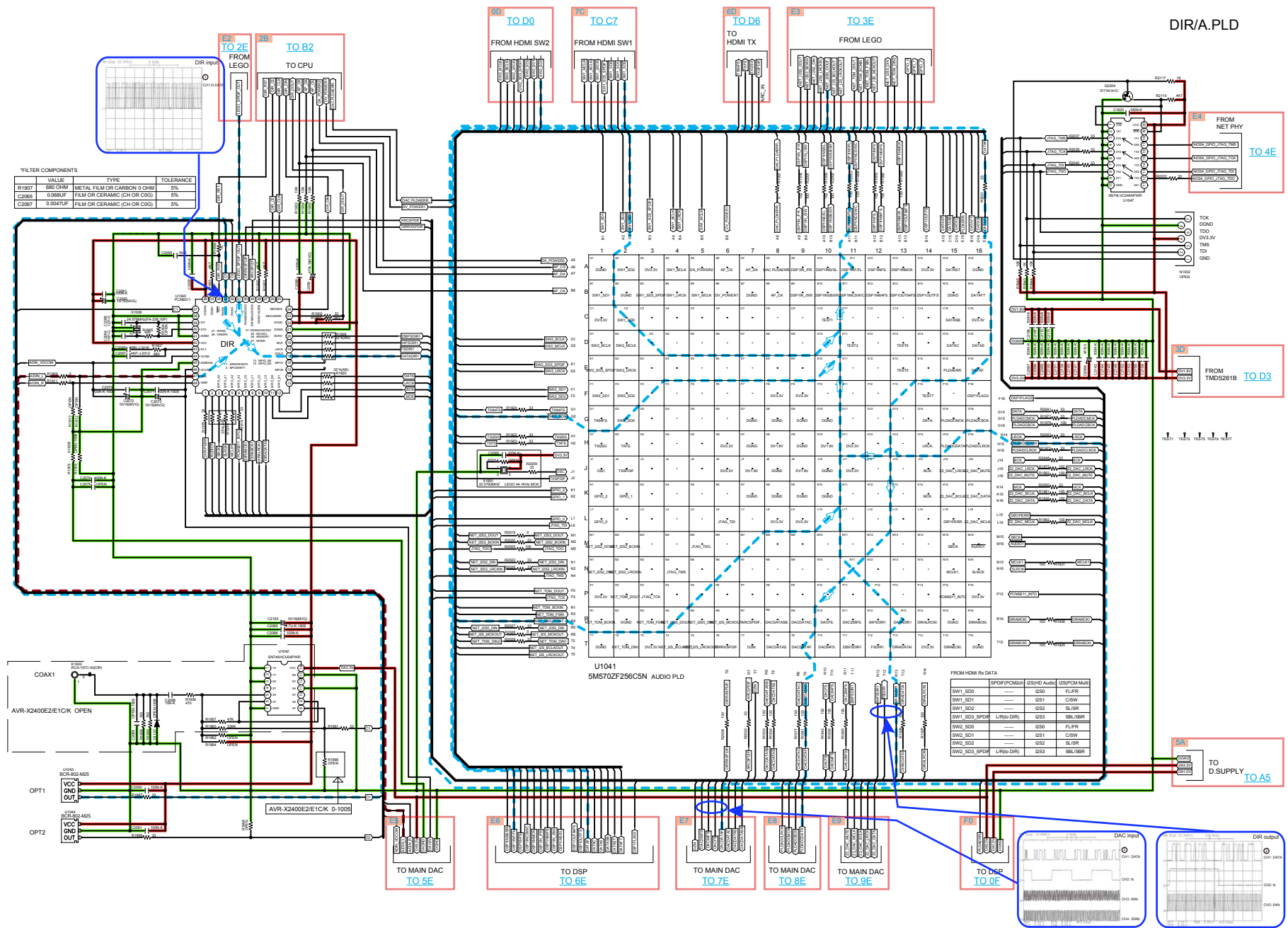

Caution in servicing

Electrical

Mechanical

Repair Information

Updating

DSP

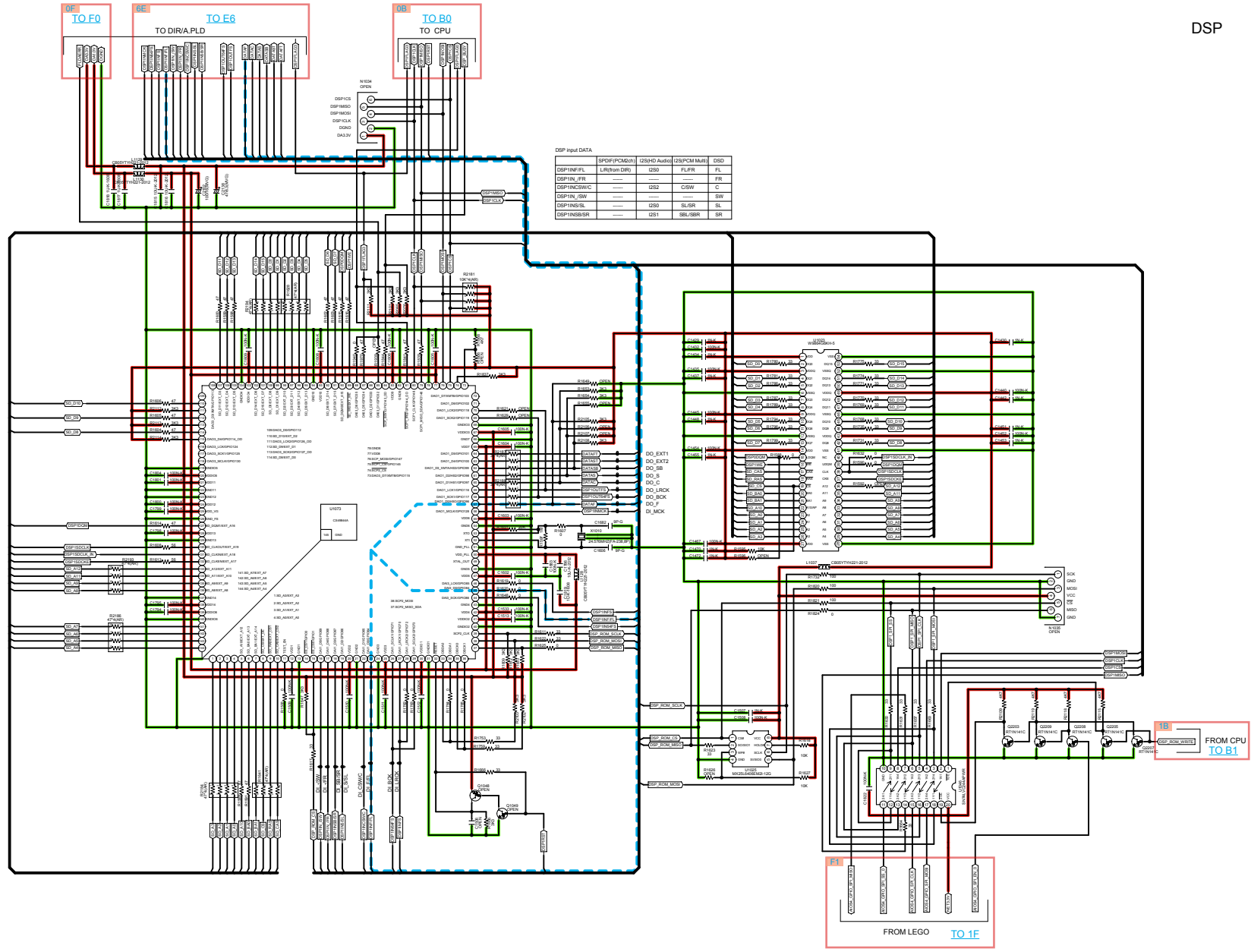

— GND LINE
 — POWER+ LINE
 — POWER- LINE
 — ANALOG AUDIO
 — DIGITAL AUDIO
 — TMSD SIGNAL
 — ANALOG VIDEO
 — DIGITAL VIDEO
 — HDMI
 — STB POWER

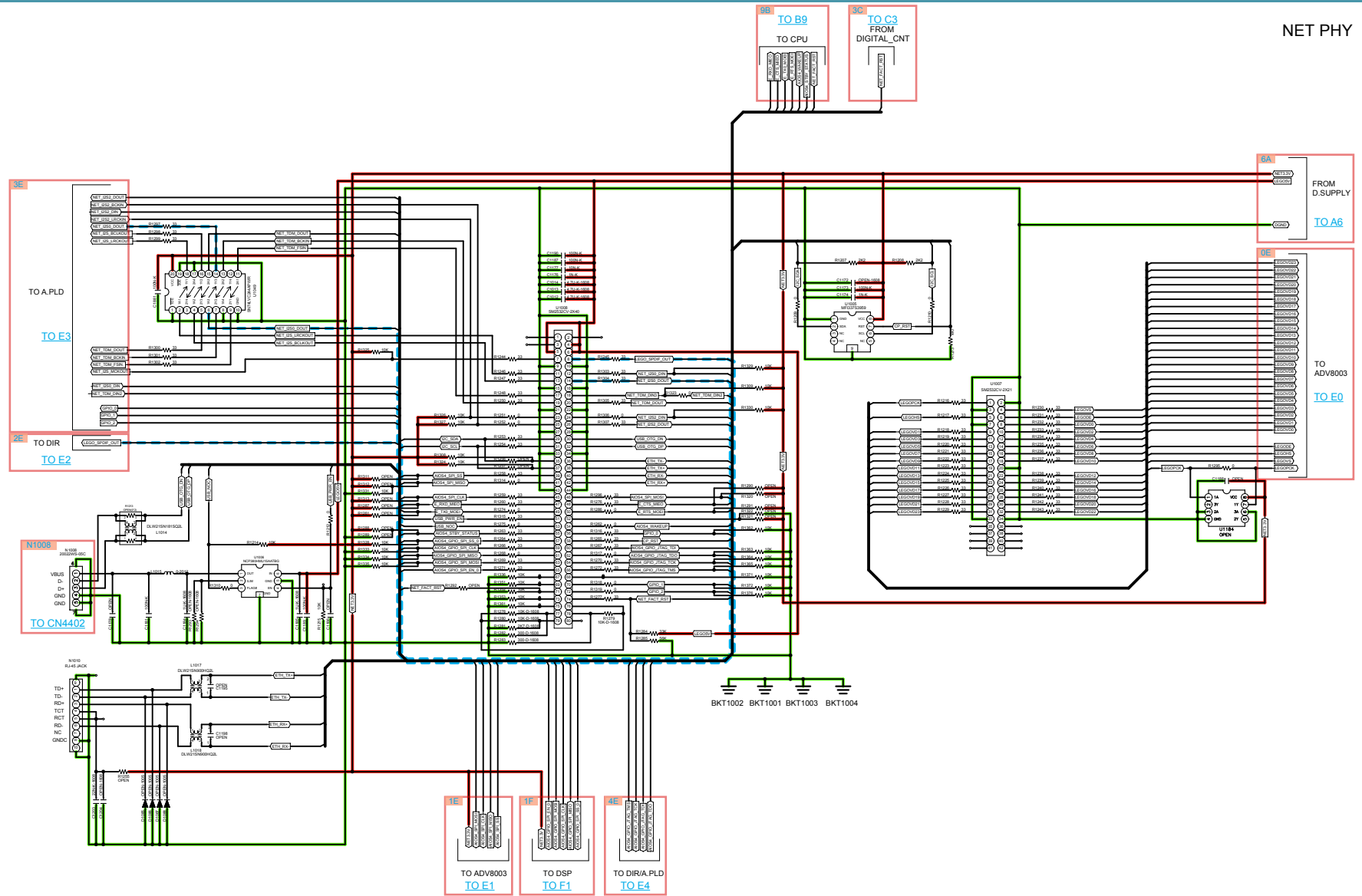

NET PHY

- GND LINE
- POWER+ LINE
- POWER- LINE
- ANALOG AUDIO
- DIGITAL AUDIO
- TMDS SIGNAL
- ANALOG VIDEO
- DIGITAL VIDEO
- HDMI
- STBY POWER

Caution in servicing
 Electrical
 Mechanical
 Repair Information
 Updating

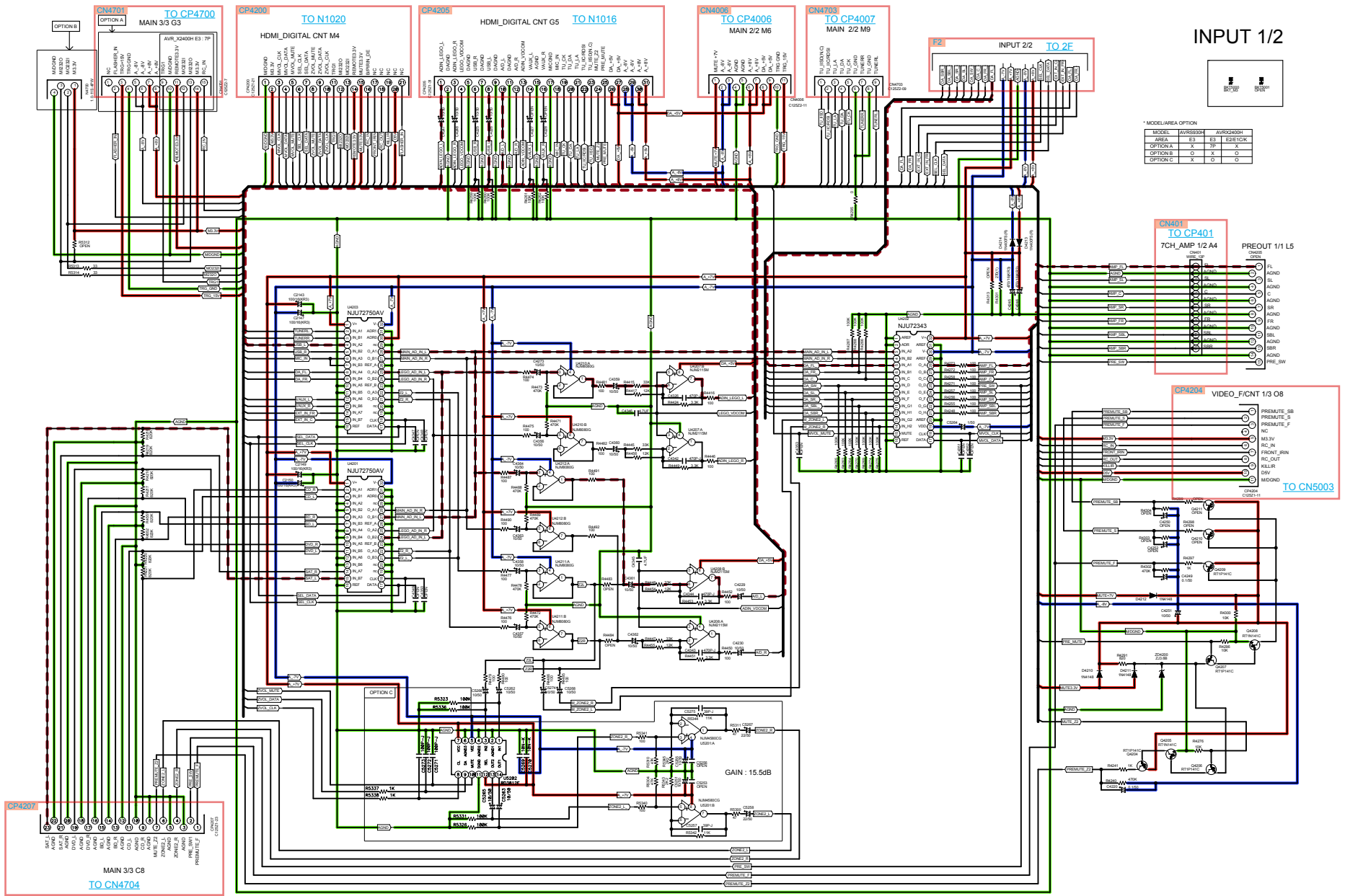

Caution in servicing

Electrical

Mechanical

Repair Information

Updating

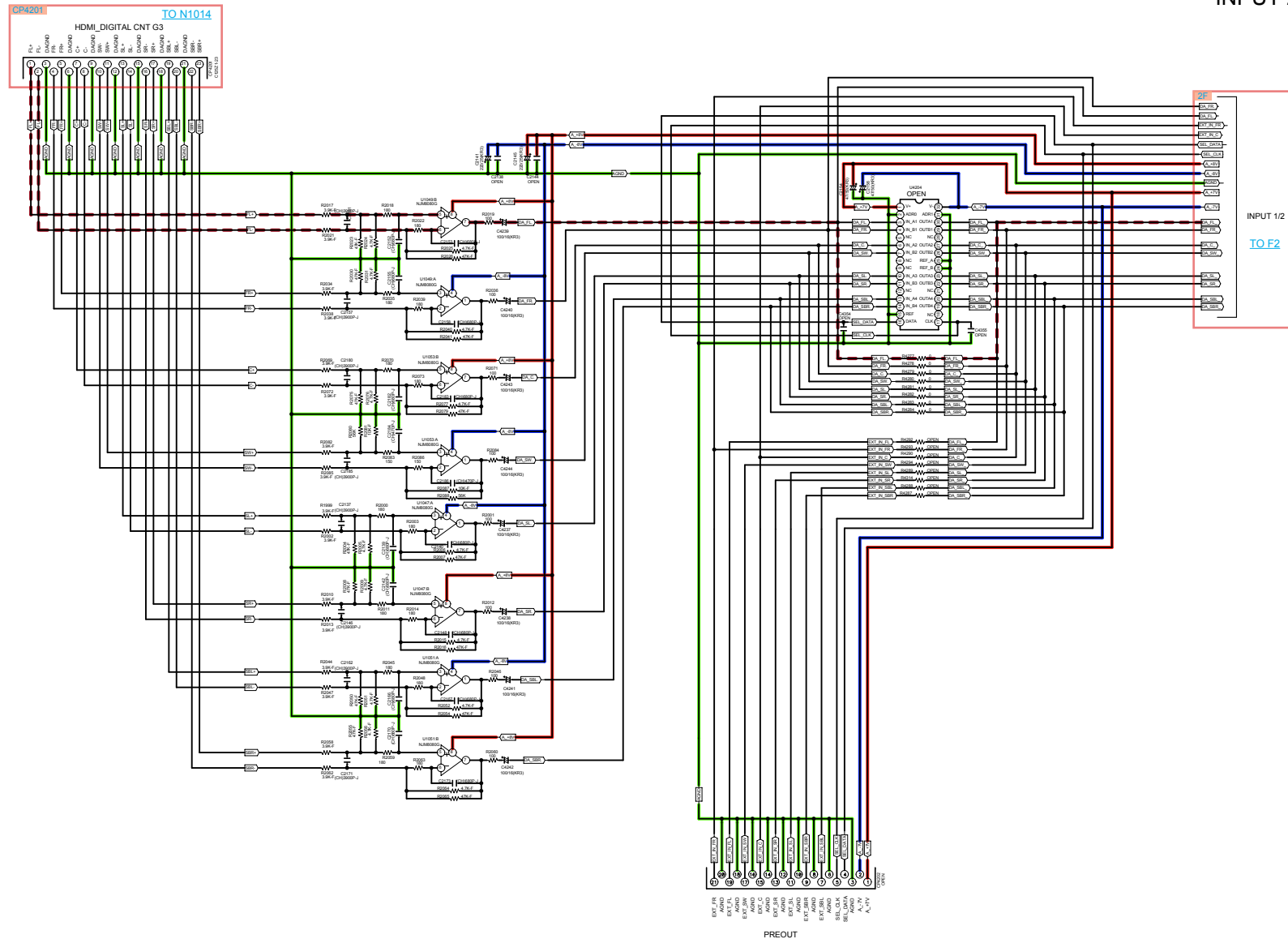

- GND LINE
- POWER+ LINE
- POWER- LINE
- ANALOG AUDIO
- DIGITAL AUDIO
- TMDS SIGNAL
- ANALOG VIDEO
- DIGITAL VIDEO
- HDMI
- STBY POWER

VIDEO PART

VIDEO_F/CNT 1/3

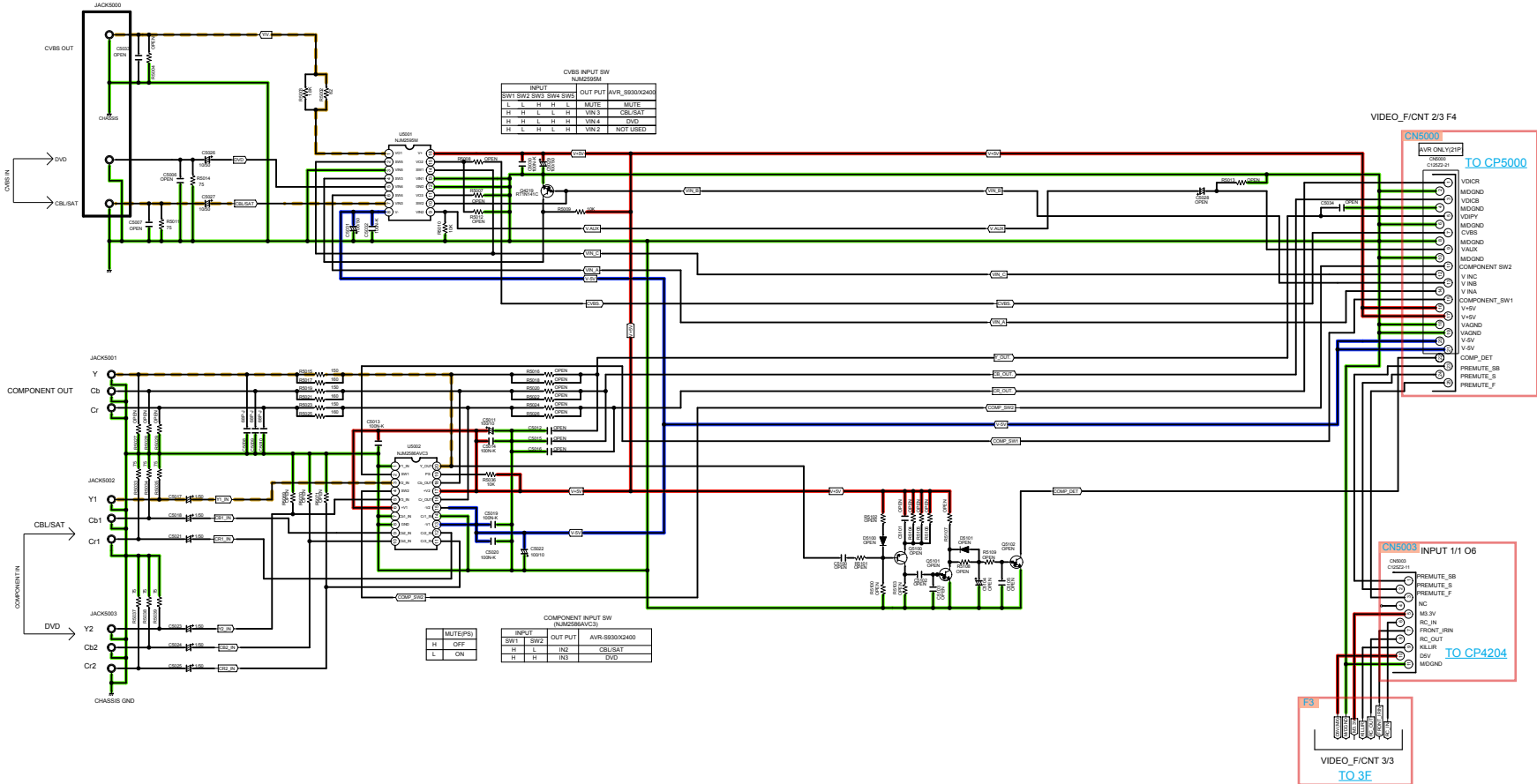

GND LINE POWER+ LINE POWER- LINE ANALOG AUDIO DIGITAL AUDIO TMD5 SIGNAL ANALOG VIDEO DIGITAL VIDEO HDMI STBY POWER

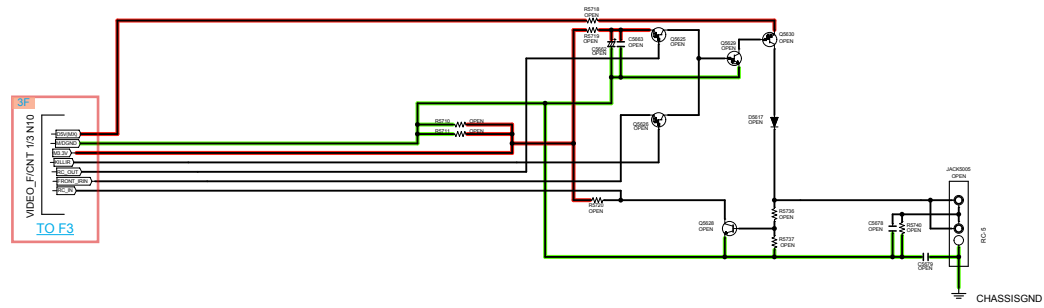

— GND LINE
 — POWER+ LINE
 — POWER- LINE
 — ANALOG AUDIO
 — DIGITAL AUDIO
 — TMDS SIGNAL
 — ANALOG VIDEO
 — DIGITAL VIDEO
 — HDMI
 — STBY POWER

S930_X2400 AMP SCH

7CH_AMP

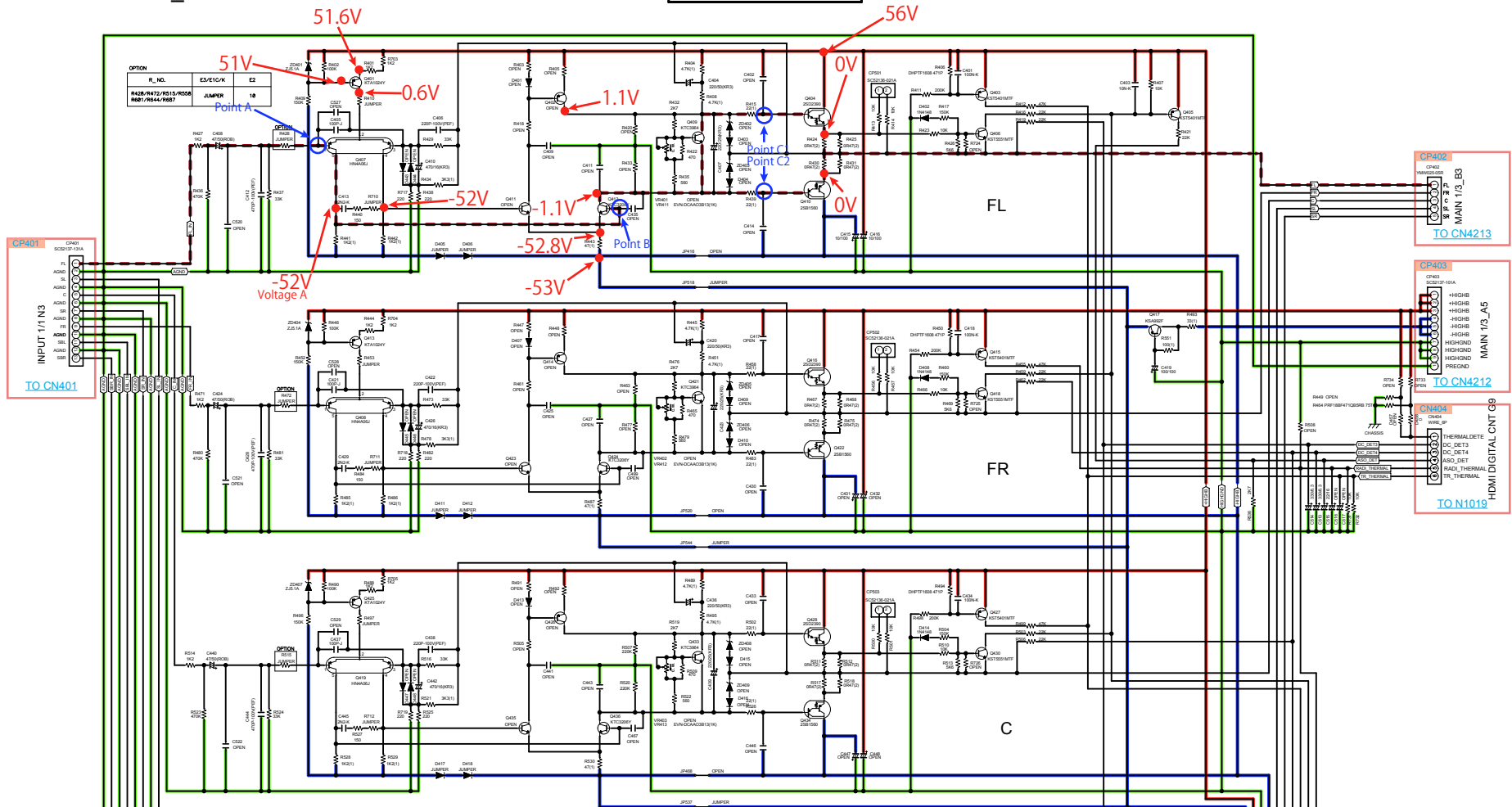

OPTION	FL_NO.	ES/1C/K	C2
R426/R427/R410/R408		JUMPER	18
R421/R444/R487			

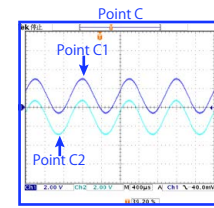
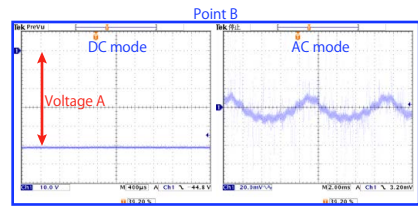
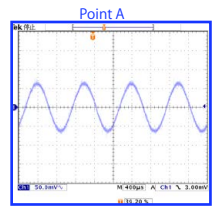

Measurement condition
 • Voltage measurement
 No signal
 • Waveform measurement
 INPUT: 200mVrms / 1KHz (ANALOG)
 Surround mode: MCh Stereo
 VOL: 70
 Speaker load: 8ohms

PAGE 2
 AMP BD 2/2_M1

- GND LINE
- POWER+ LINE
- POWER- LINE
- ANALOG AUDIO
- DIGITAL AUDIO
- TMD5 SIGNAL
- ANALOG VIDEO
- DIGITAL VIDEO
- HDMI
- STBY POWER

Caution in servicing

Electrical

Mechanical

Repair Information

Updating

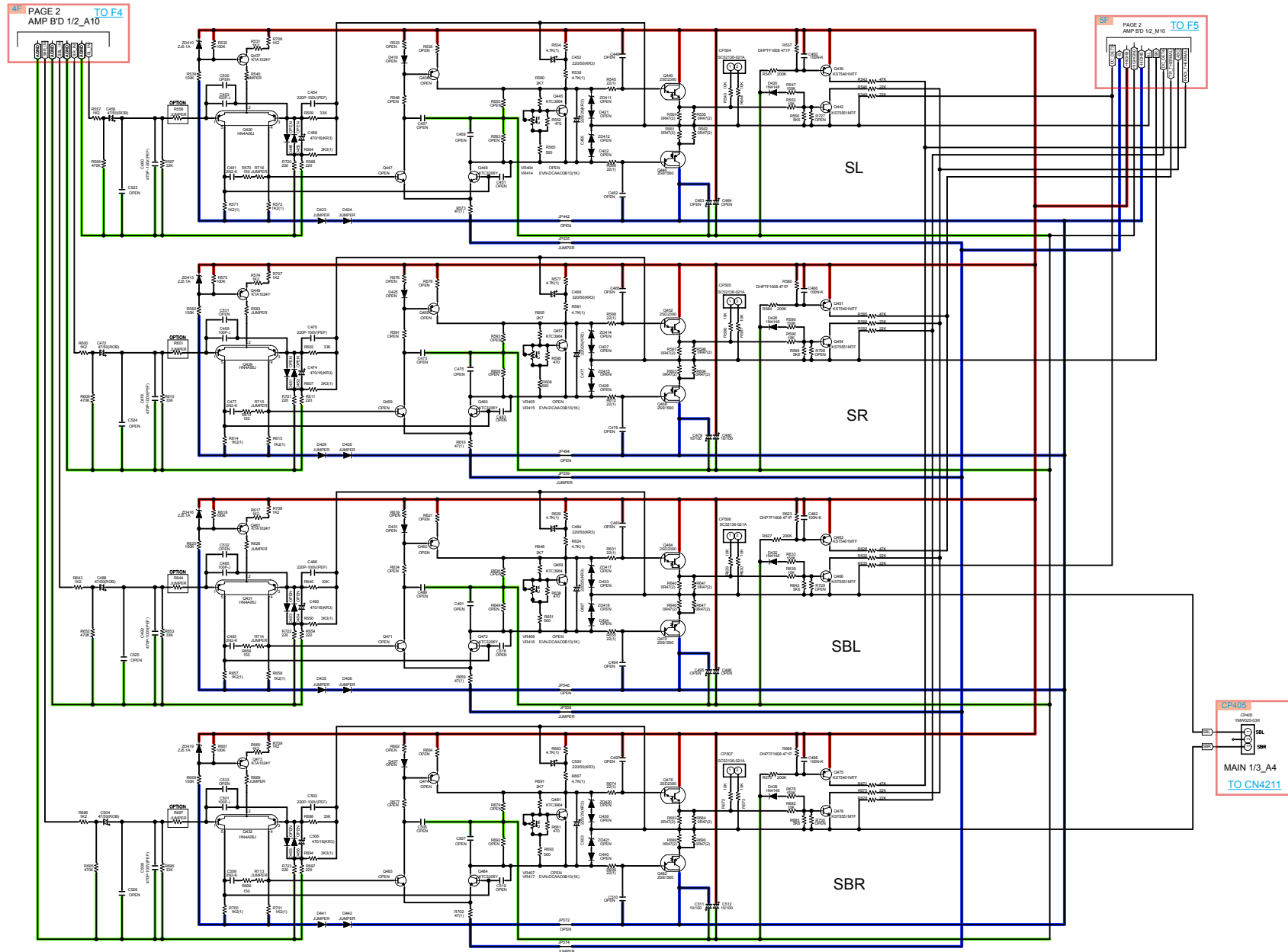

GND LINE POWER+ LINE POWER- LINE ANALOG AUDIO DIGITAL AUDIO TMDS SIGNAL ANALOG VIDEO DIGITAL VIDEO HDMI STBY POWER

SPK PART

MAIN 1/3

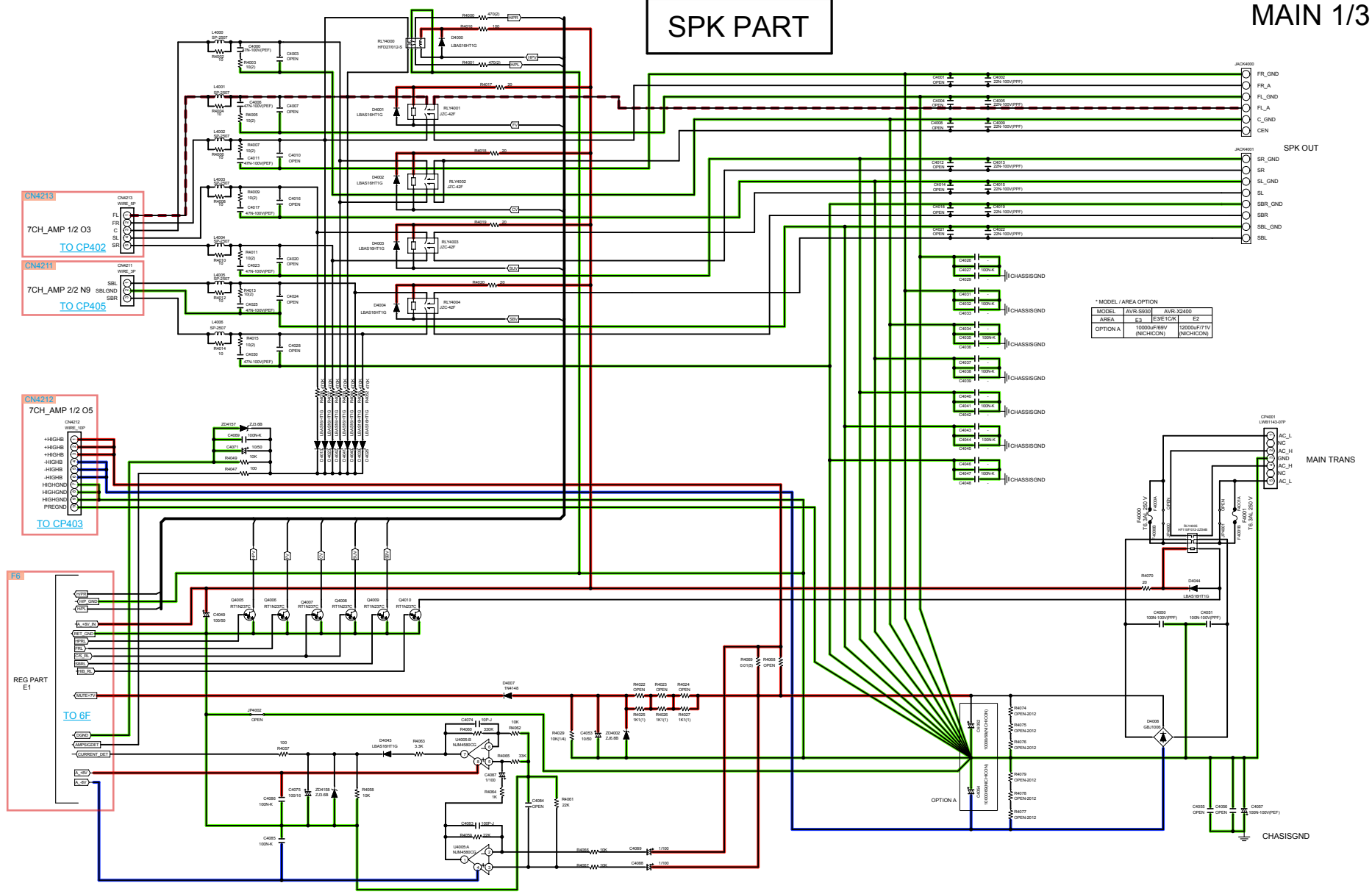

* MODEL / AREA OPTION

MODEL	AVR-5930	AVR-X2400
AREA	E3	E2
OPTION A	1000μF/50V (NICHICON)	1000μF/75V (NICHICON)

Caution in servicing

Electrical

Mechanical

Repair Information

Updating

- GND LINE
- POWER+ LINE
- POWER- LINE
- ANALOG AUDIO
- DIGITAL AUDIO
- TMSD SIGNAL
- ANALOG VIDEO
- DIGITAL VIDEO
- HDMI
- STBY POWER

TUNER / REG PART

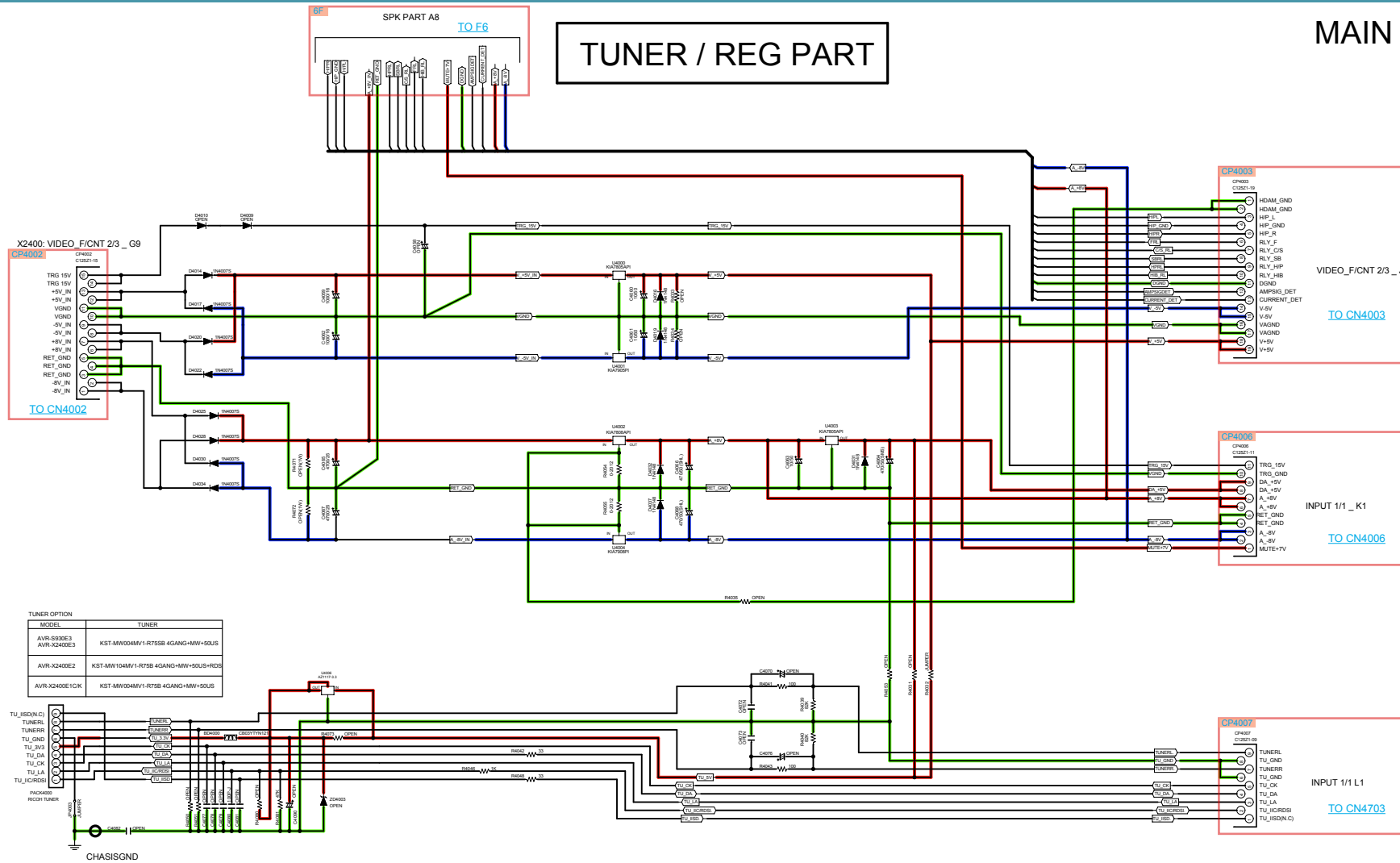

Caution in servicing

Electrical

Mechanical

Repair Information

Updating

RS_CNT PART
(AVR_X2400E3 ONLY)

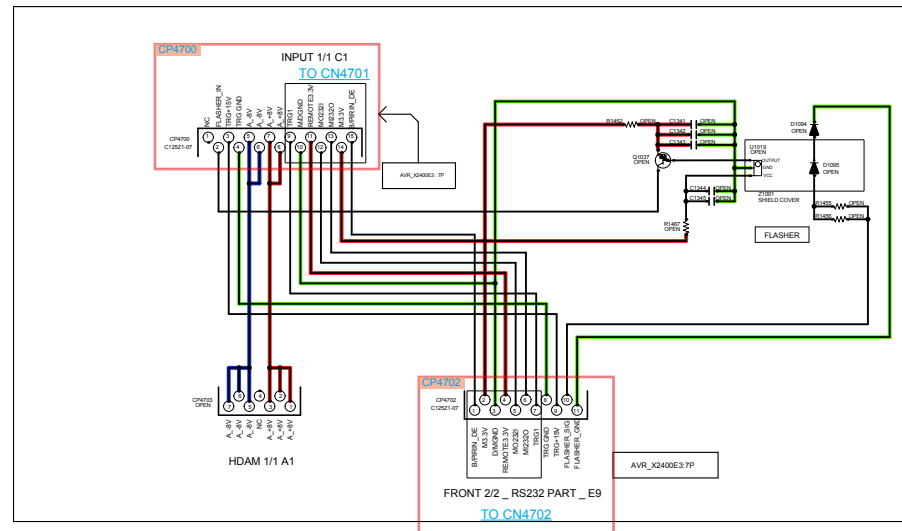

AUDIO IN PART
(AVR S930 / X2400 ONLY)

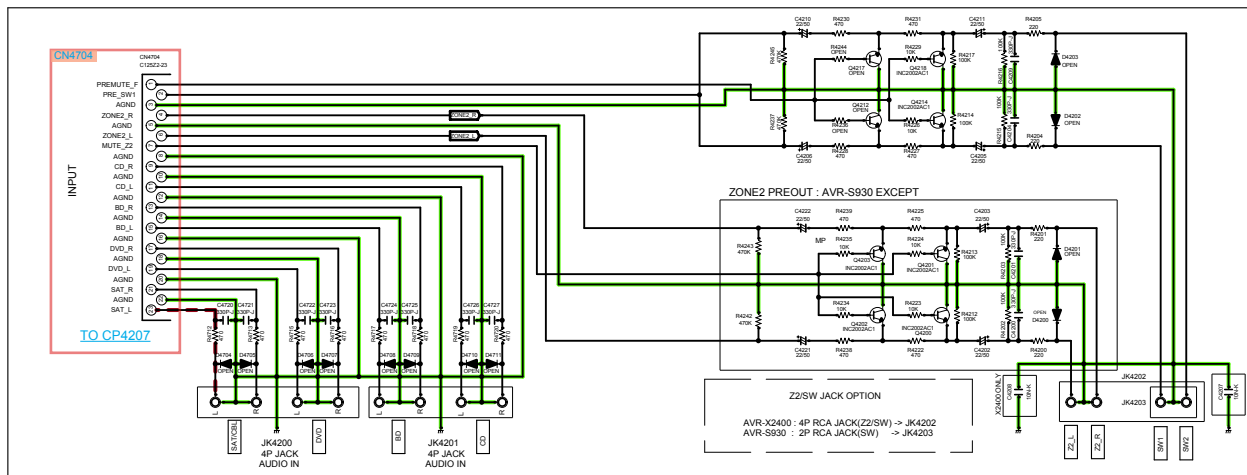

- GND LINE
- POWER+ LINE
- POWER- LINE
- ANALOG AUDIO
- DIGITAL AUDIO
- TMDS SIGNAL
- ANALOG VIDEO
- DIGITAL VIDEO
- HDMI
- STBY POWER

AVR_S930_X2400 FRONT

FRONT 1/2

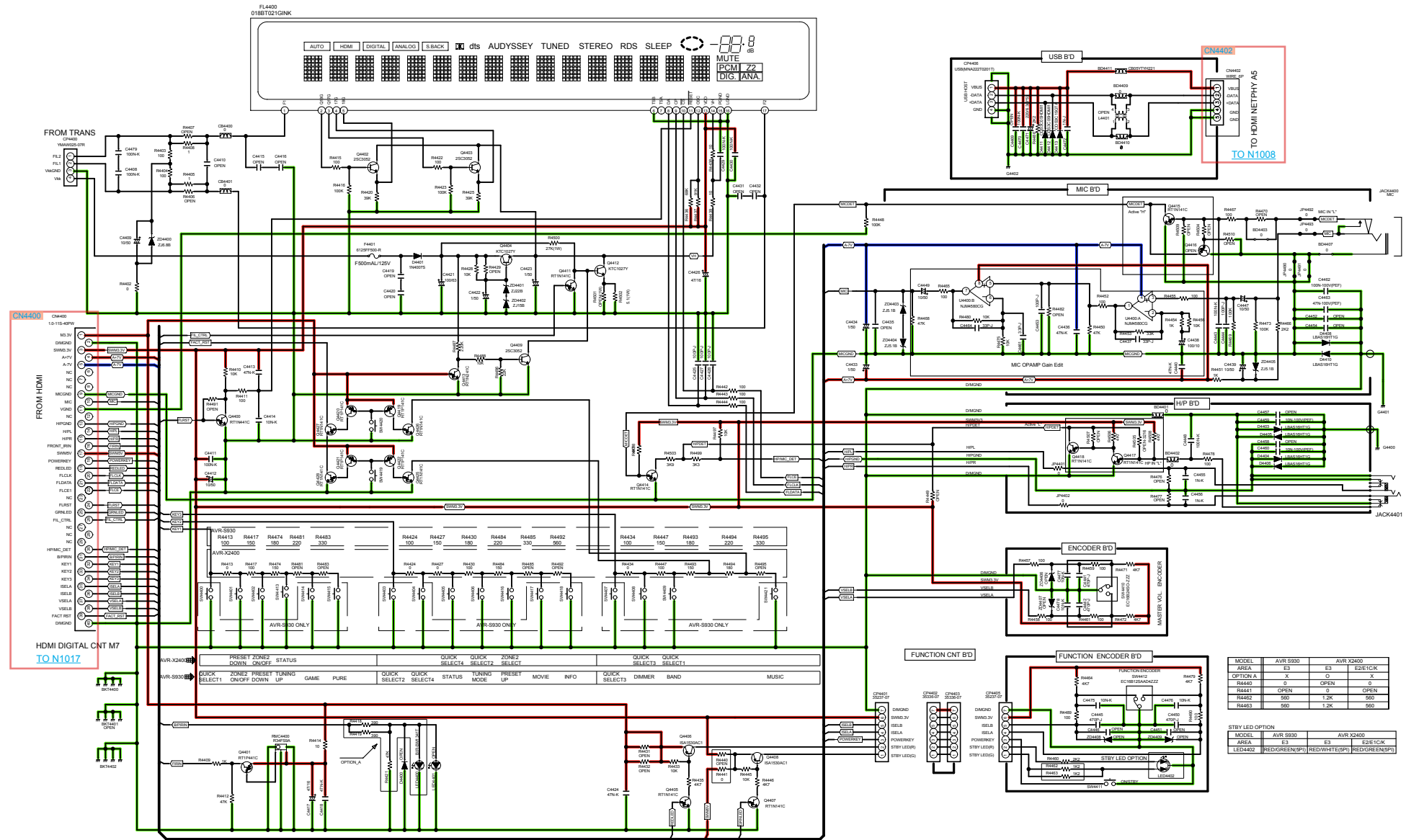

MODEL	AVR S930	AVR X2400
AREA	E3	E3
OPTION A	X	O
R4440	0	OPEN
R4441	OPEN	0
R4442	500	1.2K
R4443	500	1.2K
R4444	500	500

MODEL	AVR S930	AVR X2400
AREA	E3	E3
LED402	RED/GREEN/PI	RED/WHITE/SP
LED403	RED/GREEN/PI	RED/GREEN/SP

GND LINE POWER+ LINE POWER- LINE ANALOG AUDIO DIGITAL AUDIO TMDS SIGNAL ANALOG VIDEO DIGITAL VIDEO HDMI STBY POWER

Caution in servicing

Electrical

Mechanical

Repair Information

Updating

RS232 PART
(AVR_X2400E3 ONLY)

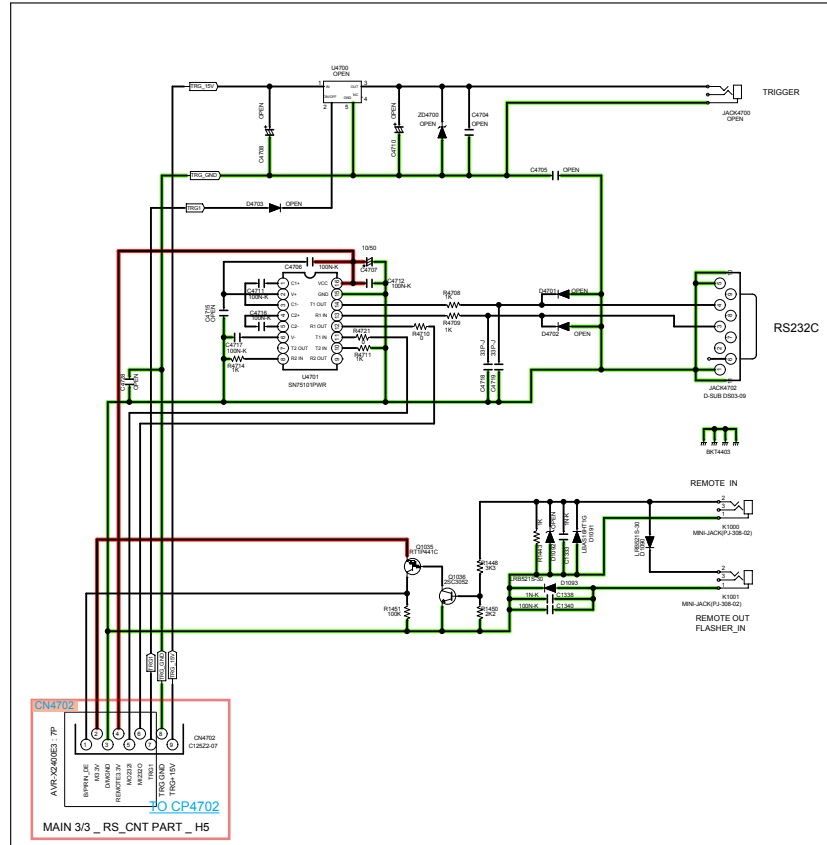

GND LINE POWER+ LINE POWER- LINE ANALOG AUDIO DIGITAL AUDIO TMDS SIGNAL ANALOG VIDEO DIGITAL VIDEO HDMI STBY POWER

AVR-S930/X2400 SMPS B'D

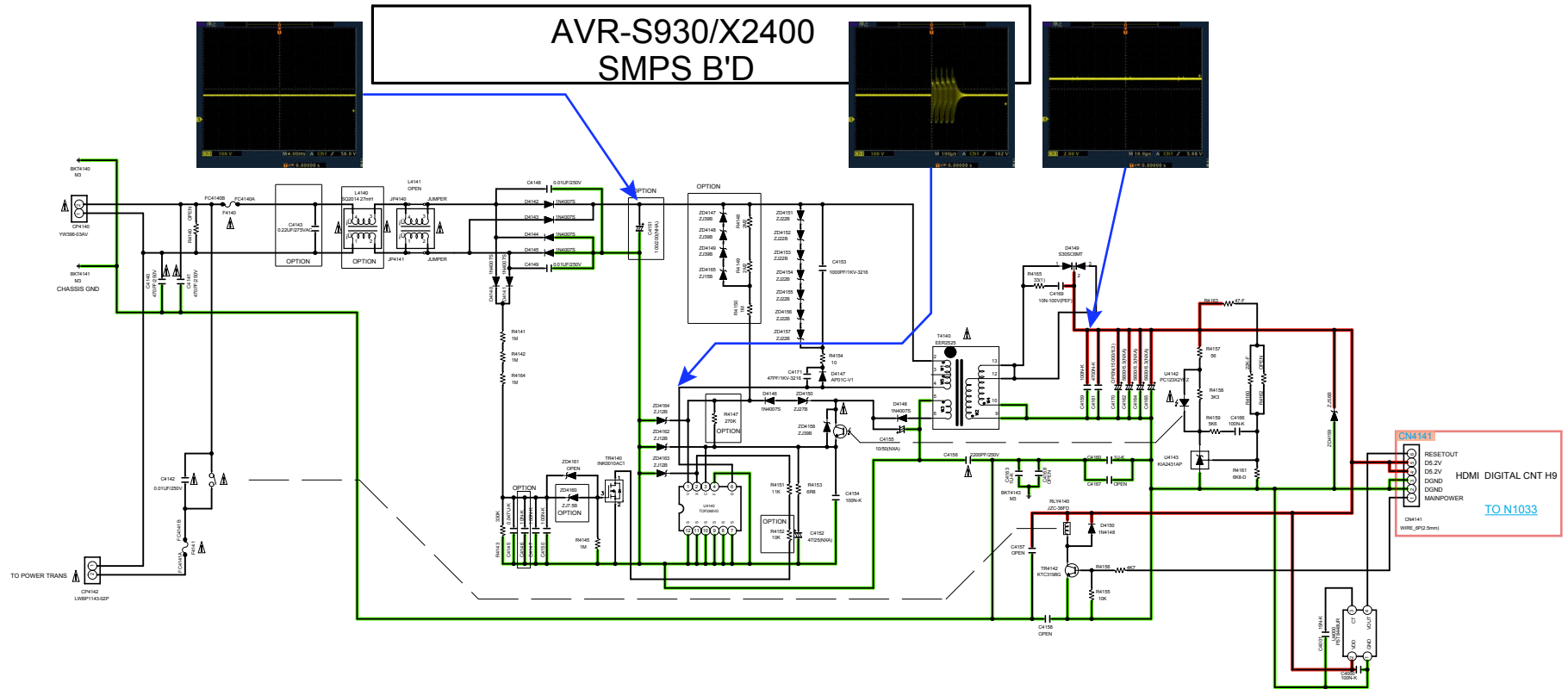

* FUSE OPTION

	E3	K(JP)	ETC. E2
F4140	F4141	F4142	F4143
AVR_X2400	T2AL	T6.3AL	T2AL
AVR_S930	T2AL	T6.3AL	X
			X

* OPTION TABLE

	ZD4160	ZD4147	ZD4148	ZD4149	R4148	R4149	R4150	R4147	L4140	C4151	R4152	C4143	C4146
E3	ZJ7.5B	ZJ39B	ZJ39B	ZJ39B	2M2 (5)	2M2 (5)	1M (5)	270K	SC2014 27mH	100/200	10K	0.22UF/275VAC	10N.K
E2	ZJ15B	OPEN	OPEN	OPEN	OPEN	OPEN	OPEN	56K	SC2014 50mH	100/400	20K	0.1UF/275VAC	10N.K
E1C	ZJ15B	OPEN	OPEN	OPEN	OPEN	OPEN	OPEN	56K	SC2014 50mH	100/400	20K	0.1UF/275VAC	100N.K
K(JP)	ZJ6.2B	ZJ39B	ZJ39B	ZJ39B	2M2 (5)	2M2 (5)	1M (5)	270K	SC2014 27mH	100/200	10K	0.22UF/275VAC	10N.K

* PCB QUALITY OPTION

	AVR E2	AVR E3, E1C, K(JP)
CP-3400(S1)		
KB-315(C)		

* AVR-S930/X2400

	ZD4165
AVR E3, K(JP)	ZJ15B
AVR E2, E1C	OPEN

⚠ INDICATES SAFETY CRITICAL COMPONENTS.
TO REDUCE THE RISK OF ELECTRIC SHOCK, LEAKAGE CURRENT OR RESISTANCE MEASUREMENTS SHALL BE CARRIED OUT (EXPOSED PARTS ARE ACCEPTABLY INSULATED FROM THE SUPPLY CIRCUIT) BEFORE THE APPLIANCE RETURNED TO THE CUSTOMER.

GND LINE POWER+ LINE POWER- LINE ANALOG AUDIO DIGITAL AUDIO TMD5 SIGNAL ANALOG VIDEO DIGITAL VIDEO HDMI STBY POWER

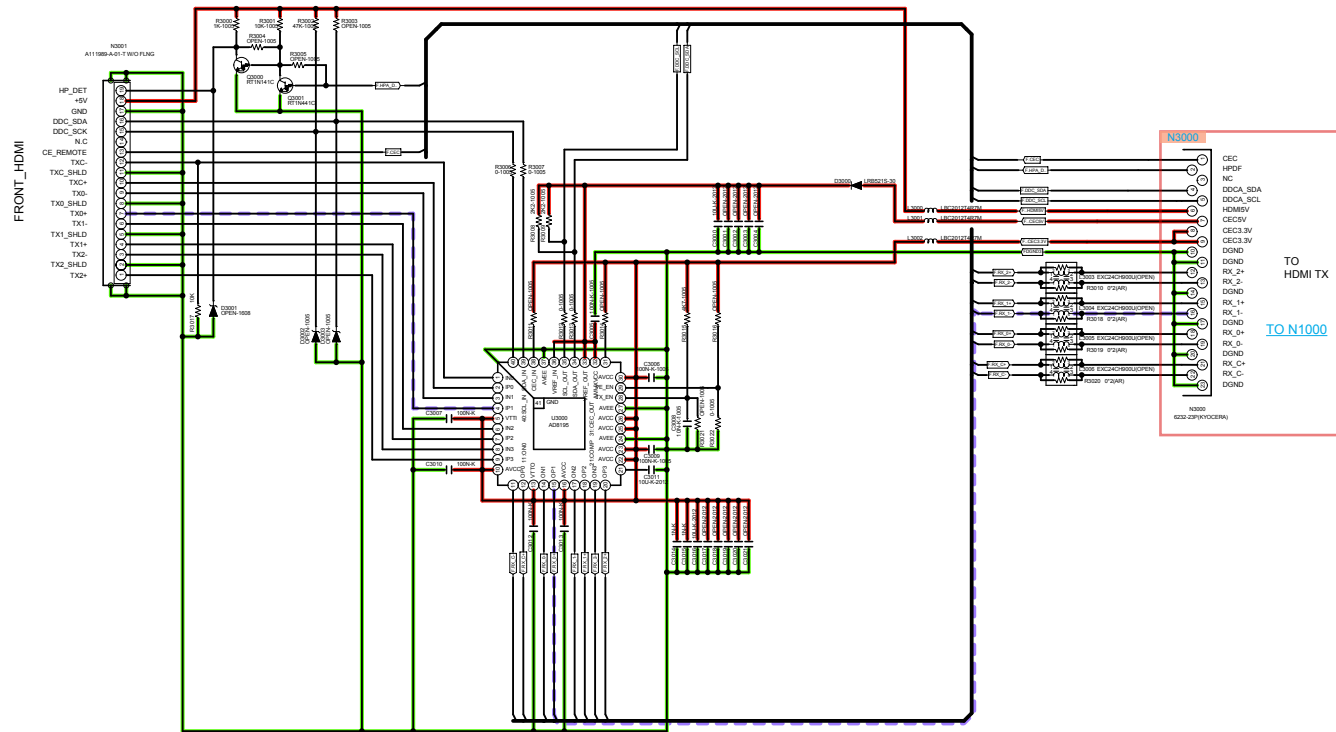

- GND LINE
- POWER+ LINE
- POWER- LINE
- ANALOG AUDIO
- DIGITAL AUDIO
- TMDS SIGNAL
- ANALOG VIDEO
- DIGITAL VIDEO
- HDMI
- STBY POWER

PRINTED CIRCUIT BOARDS

DIGITAL, F HDMI

Lead-free Solder
When soldering, use the Lead-free Solder (Sn-Ag-Cu).

DIGITAL (A SIDE)

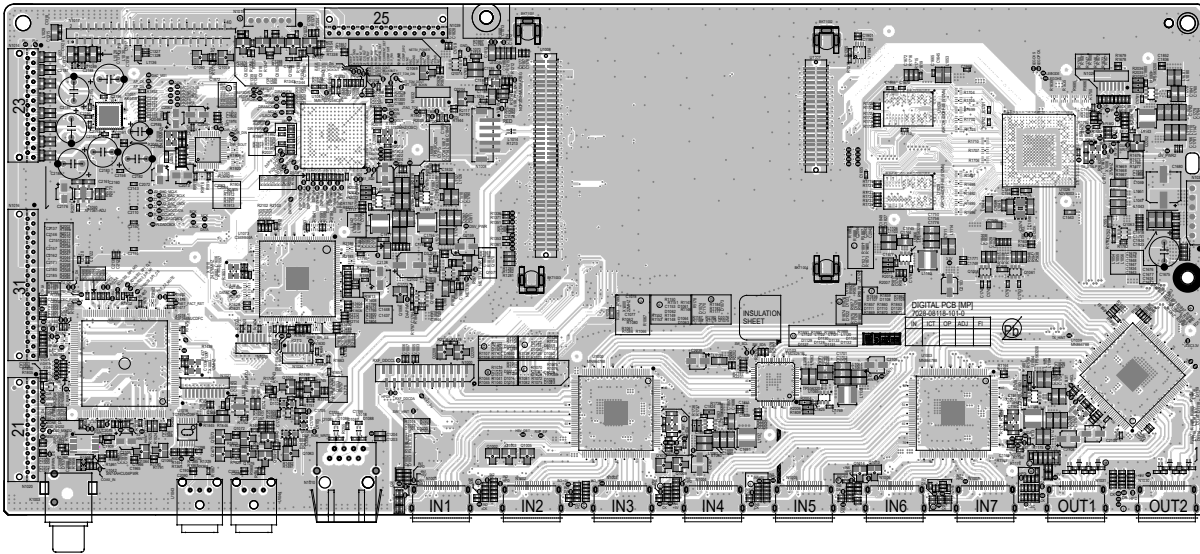

DIGITAL (B SIDE)

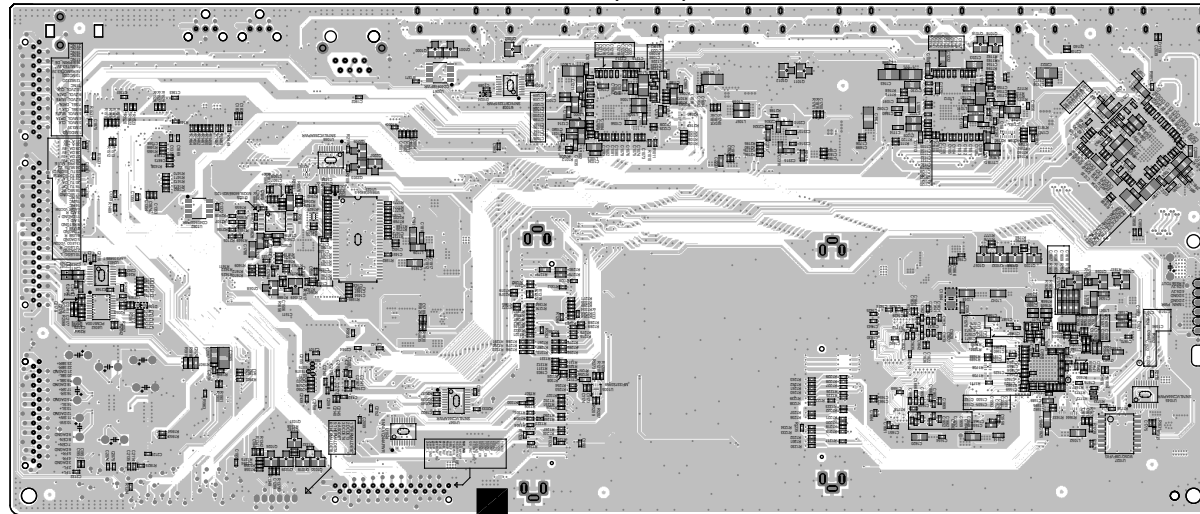

F HDMI (A SIDE) F HDMI (B SIDE)

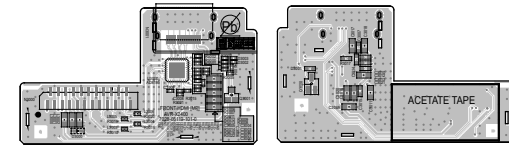

Caution in servicing

Electrical

Mechanical

Repair Information

Updating

INPUT (A SIDE)

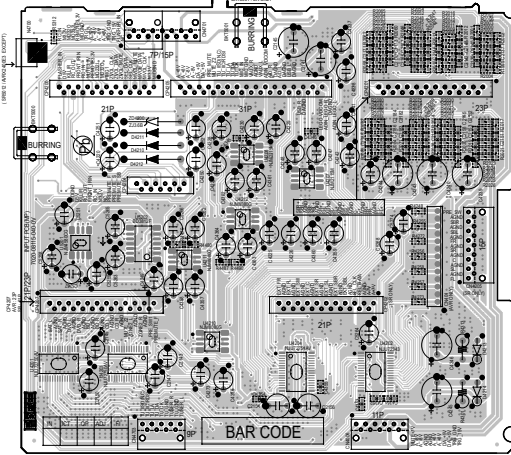

INPUT (B SIDE)

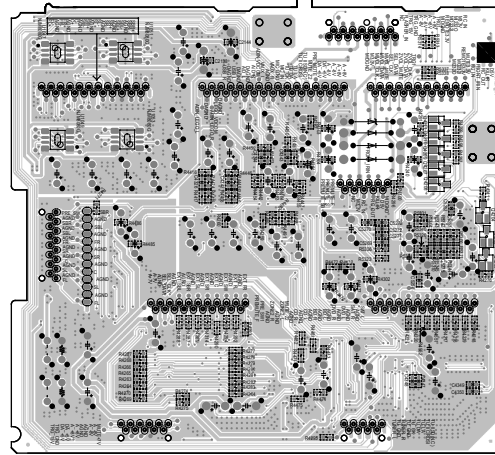

FRONT CNT (A SIDE)

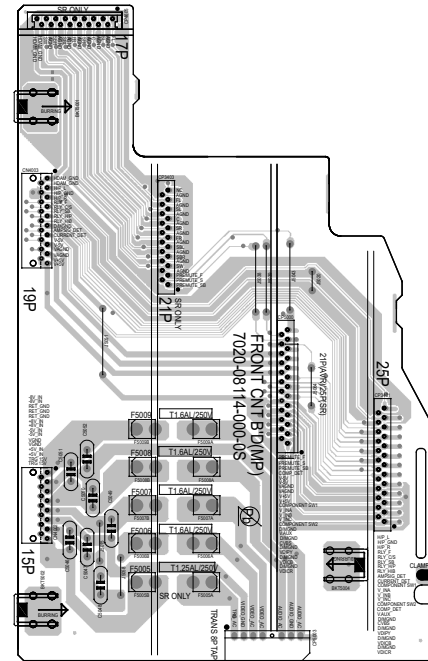

FRONT CNT (B SIDE)

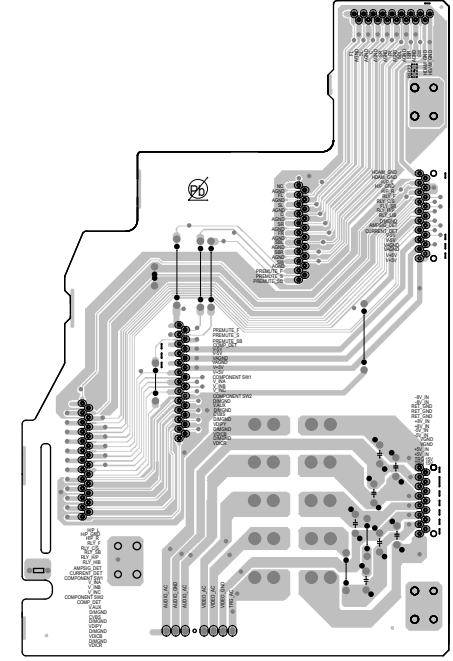

VIDEO (A SIDE)

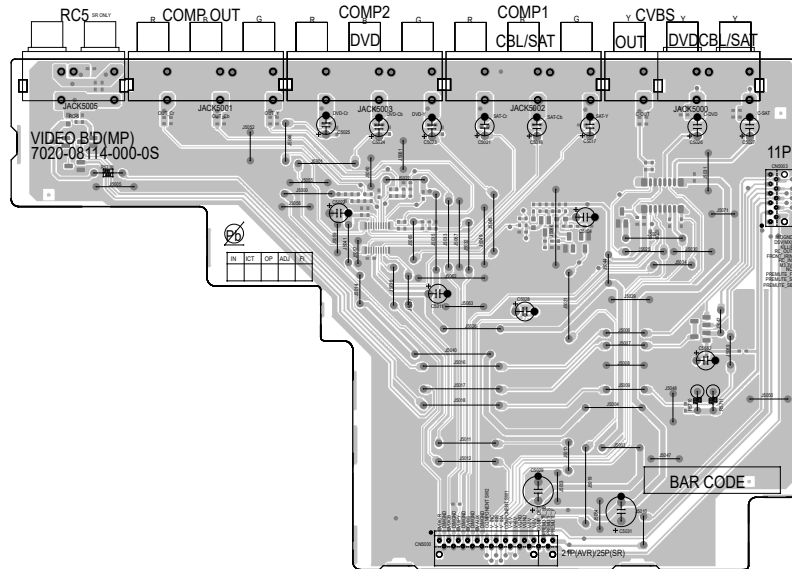

VIDEO (B SIDE)

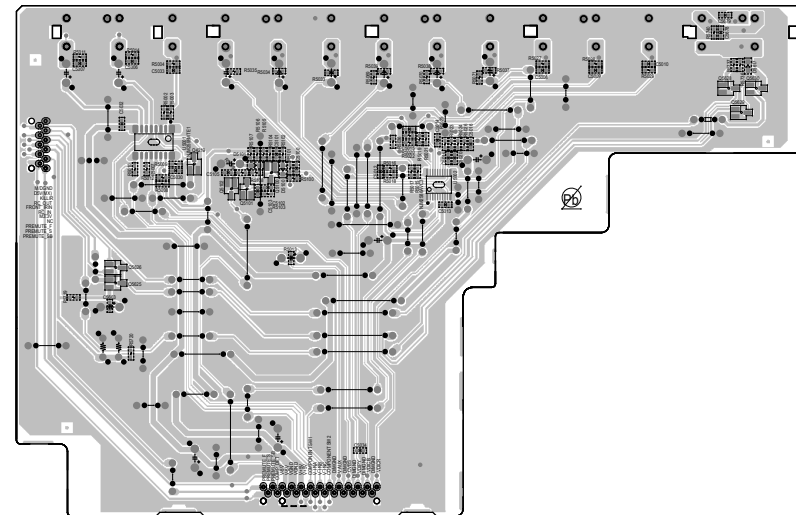

Caution in servicing

Electrical

Mechanical

Repair Information

Updating

AMP (A SIDE)

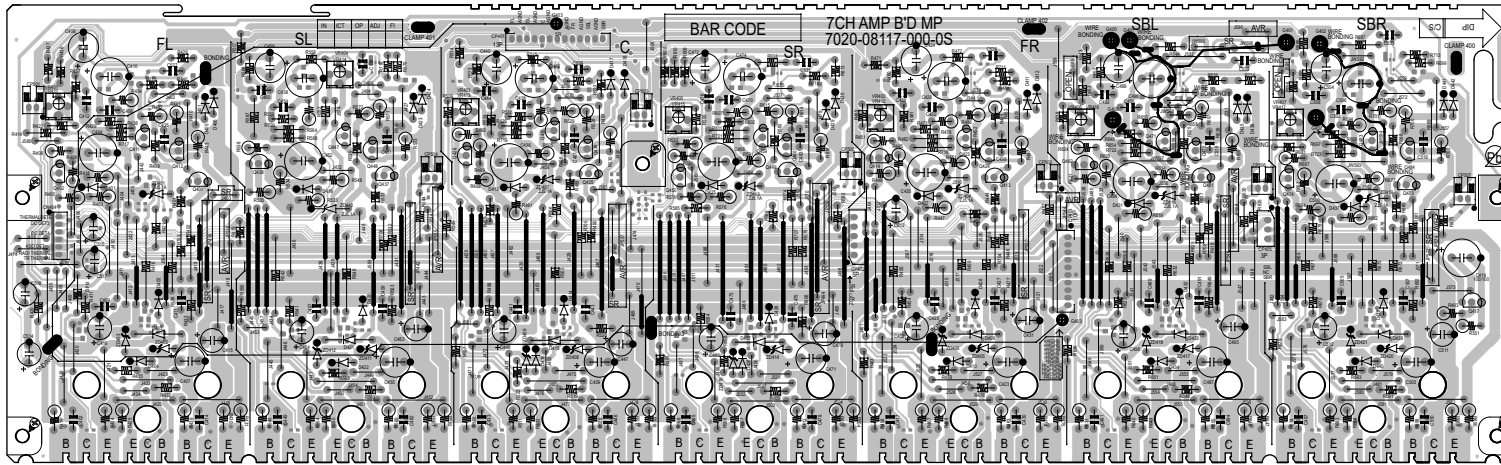

AMP (B SIDE)

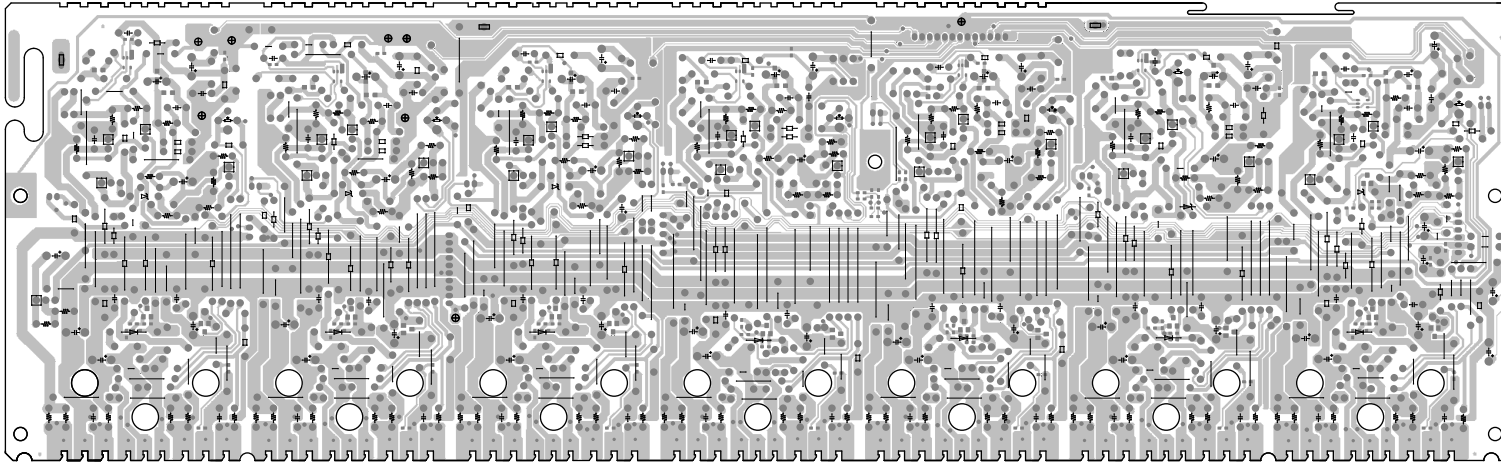

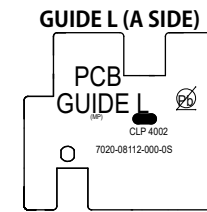
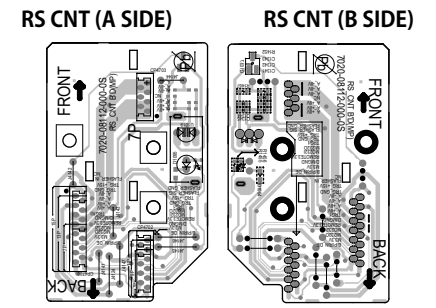
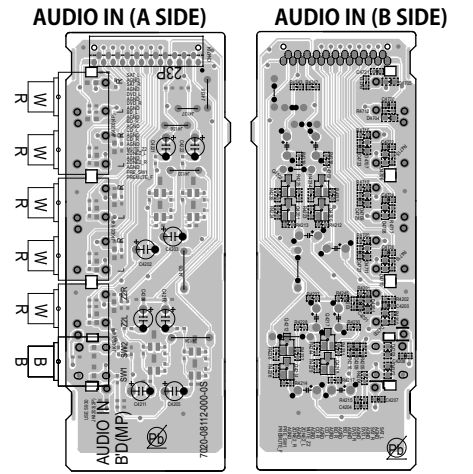
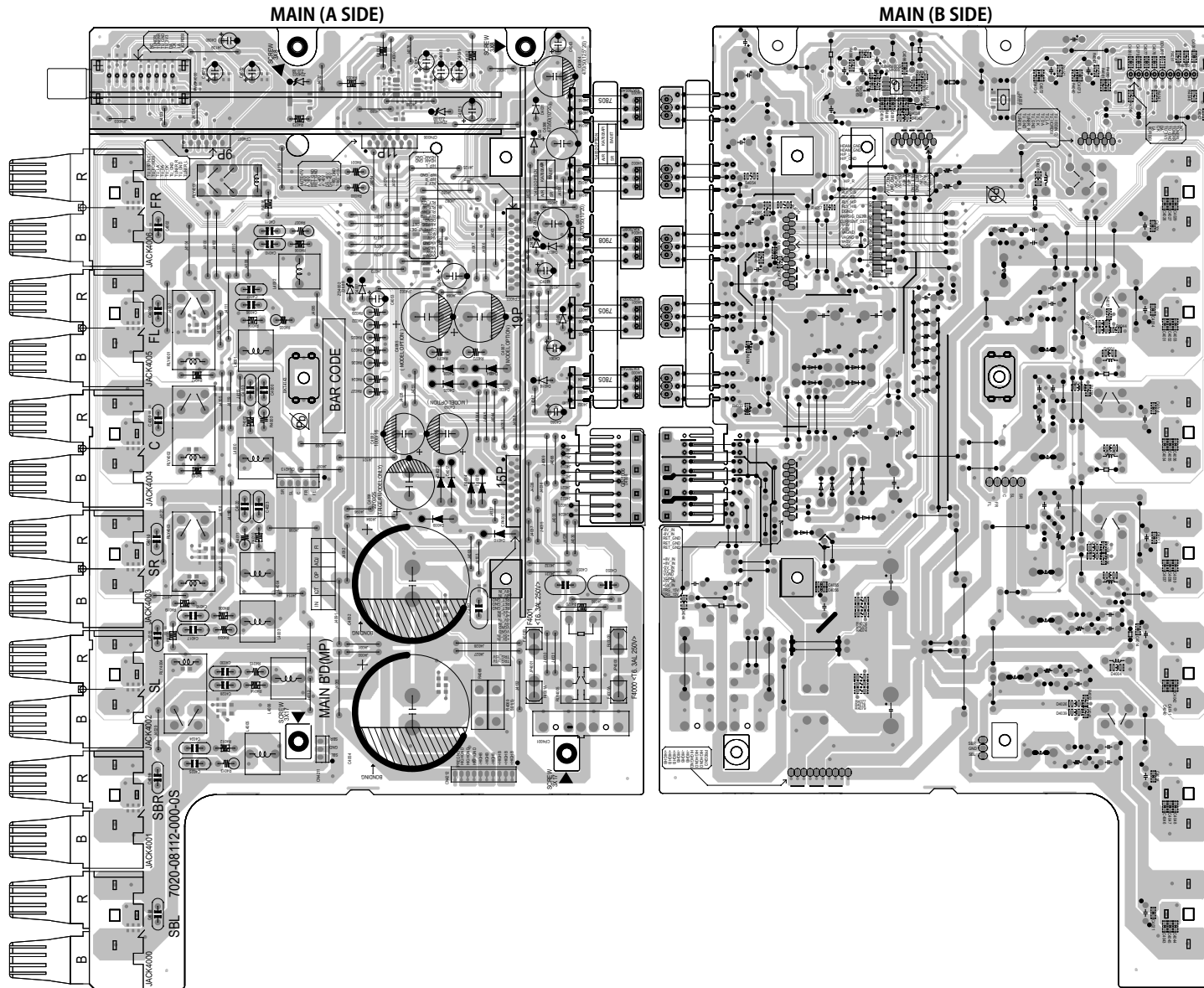

Caution in servicing

Electrical

Mechanical

Repair Information

Updating

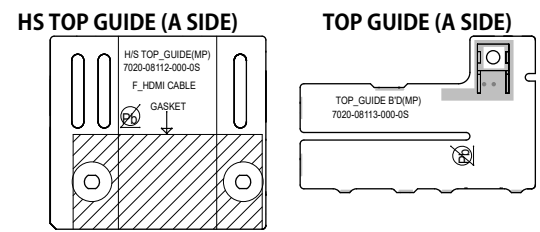
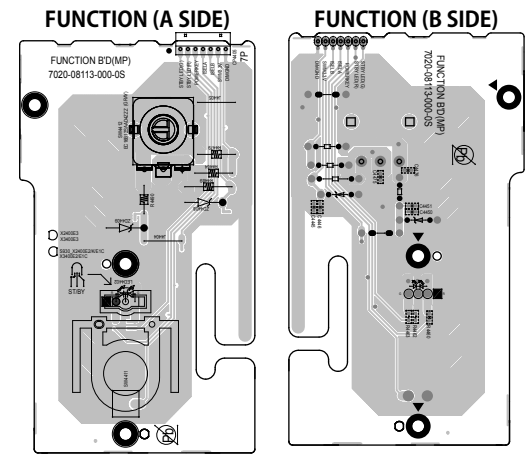
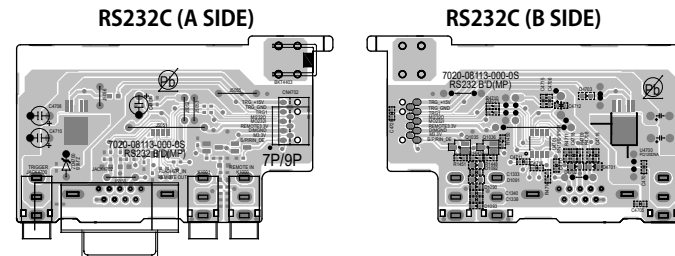
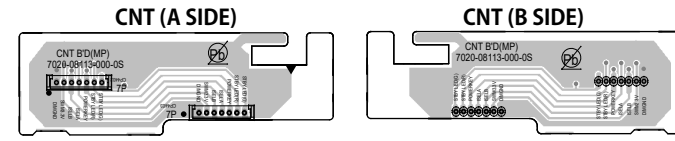
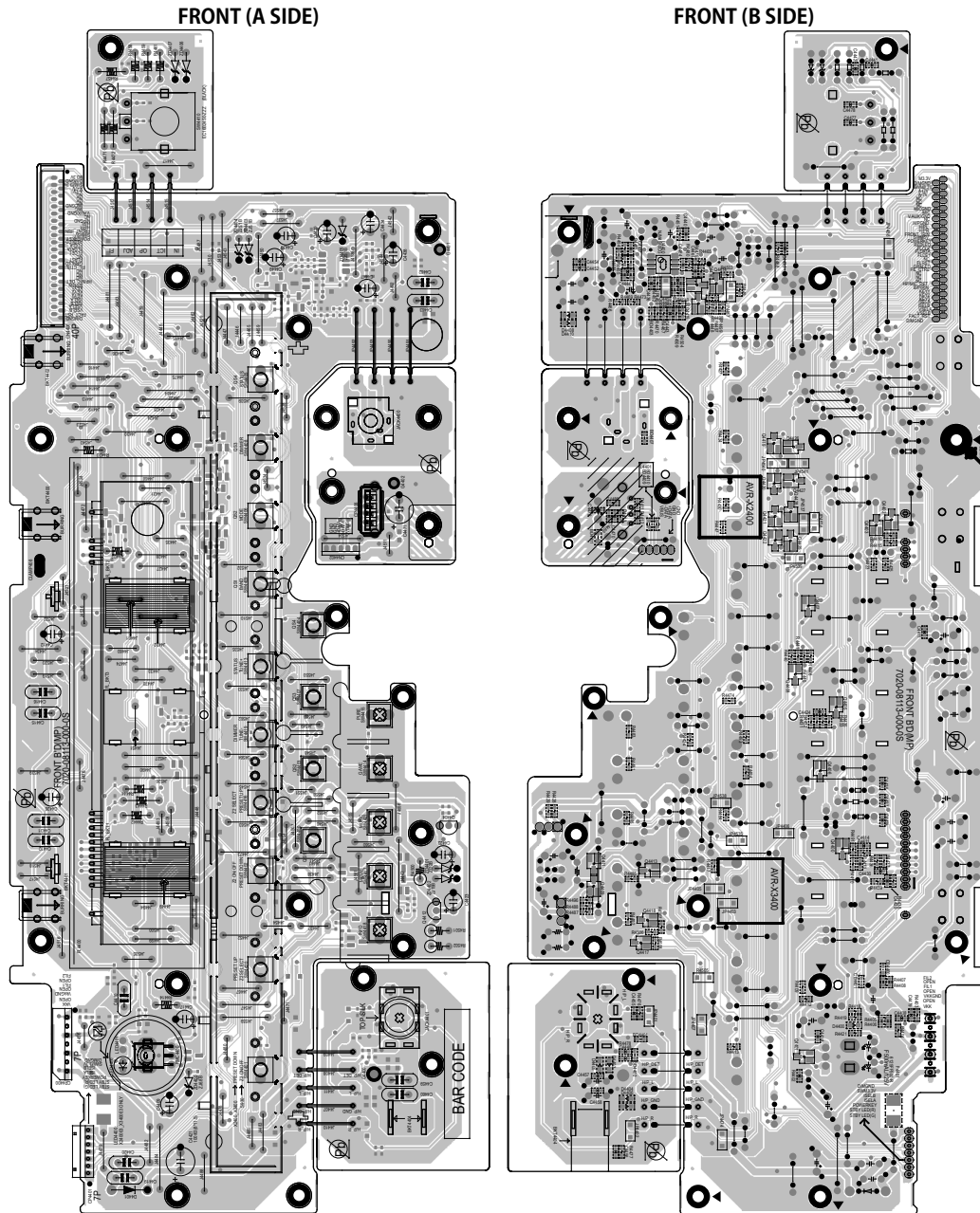

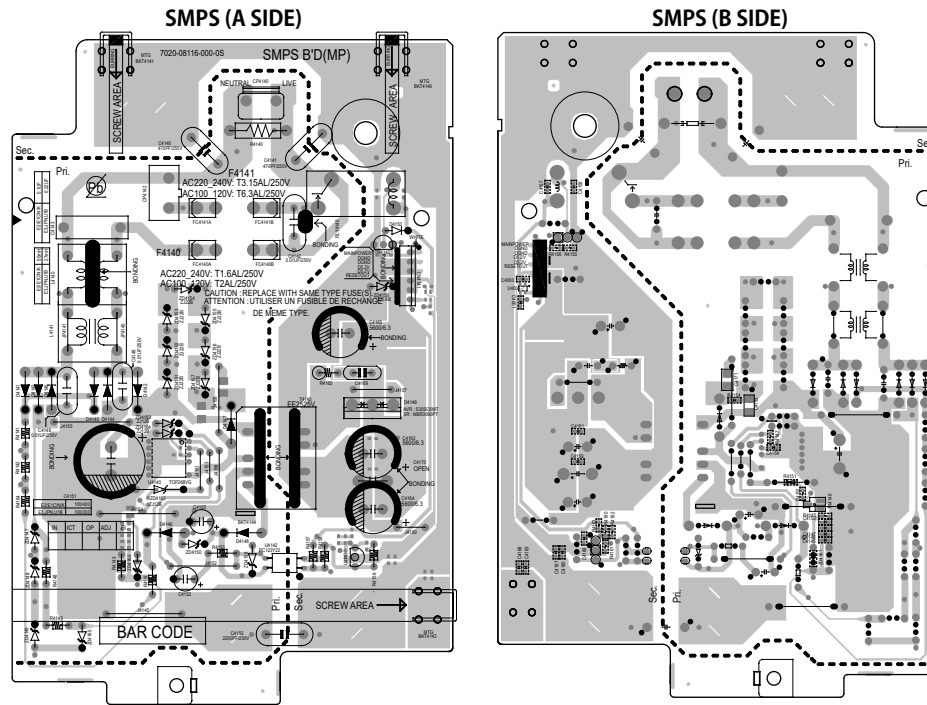

Caution in
servicing

Electrical

Mechanical

Repair Information

Updating

LEVEL DIAGRAM

FRONT ch

AVR-S930H/X2400H LEVEL DIAGRAM FRONT ch

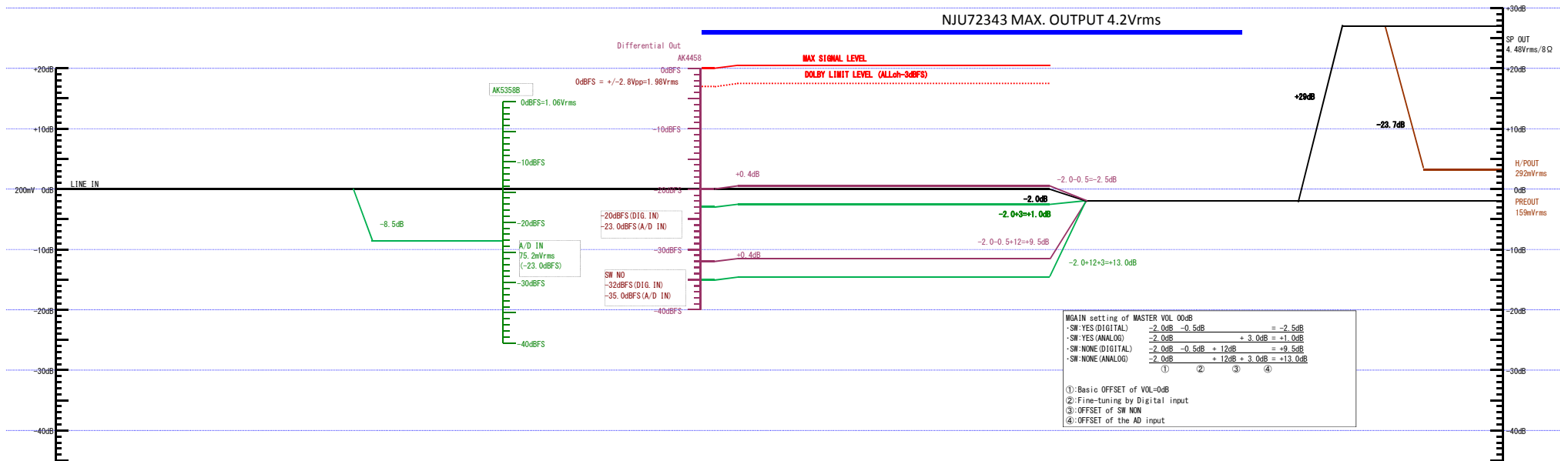
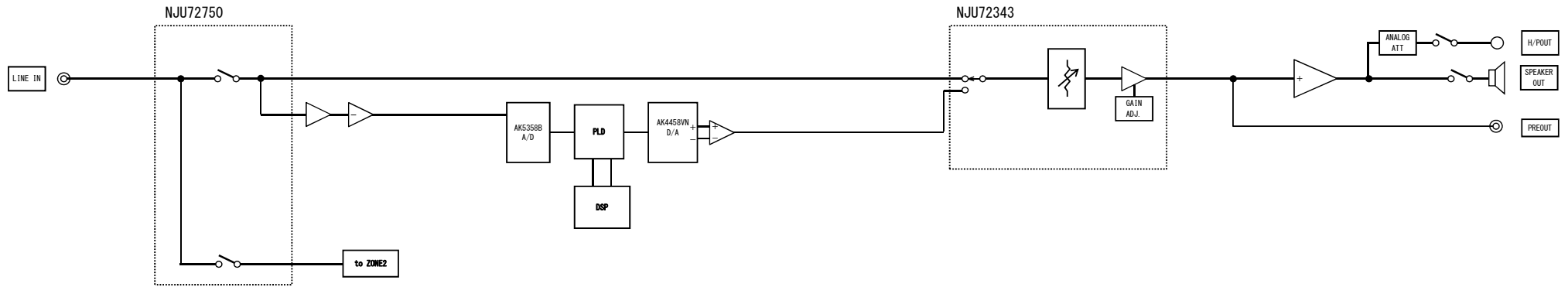

**AVR-S930H/X2400H
LEVEL DIAGRAM
CENTER ch
SURROUND ch
SURR.BCK ch**

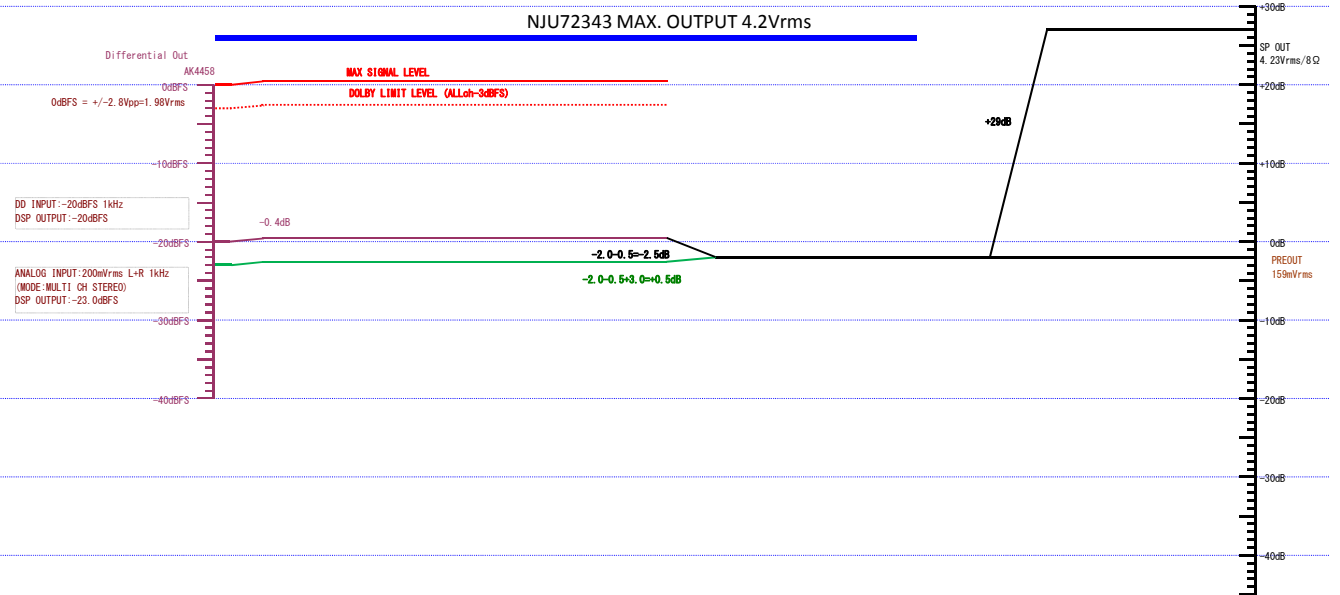
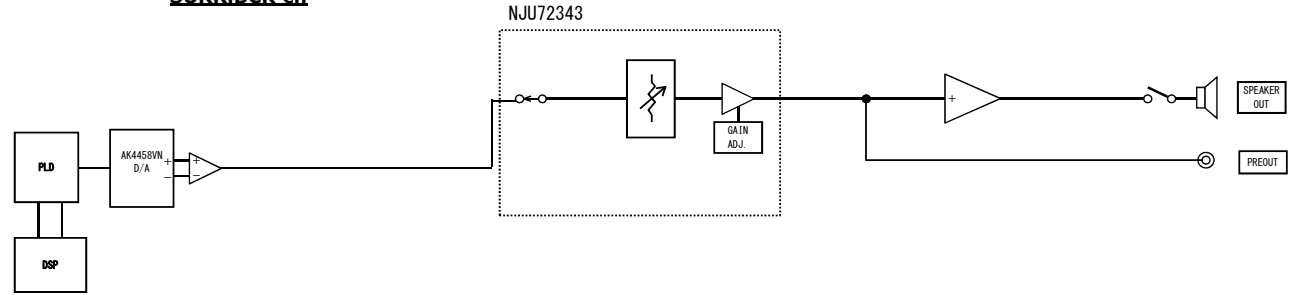

**AVR-S930H/X2400H
LEVEL DIAGRAM
SUBWOOFER ch**

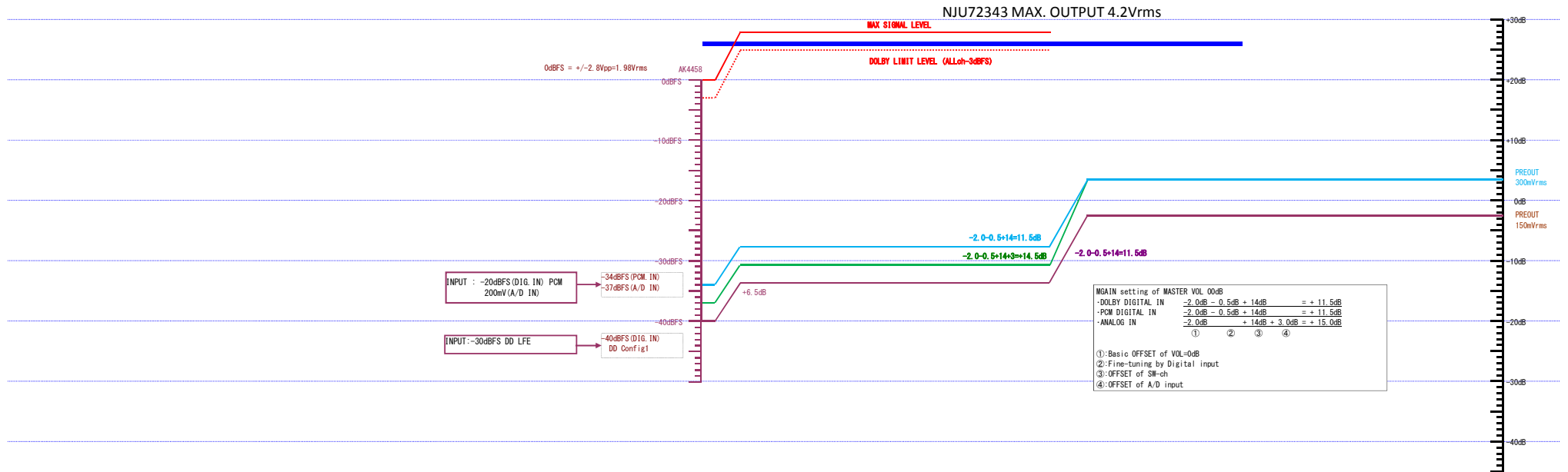
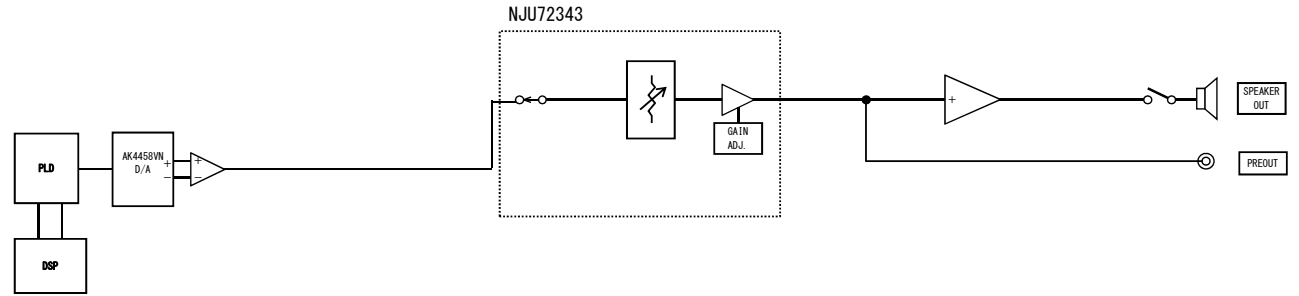

**AVR-S930H / X2400H
LEVEL DIAGRAM
ZONE2**

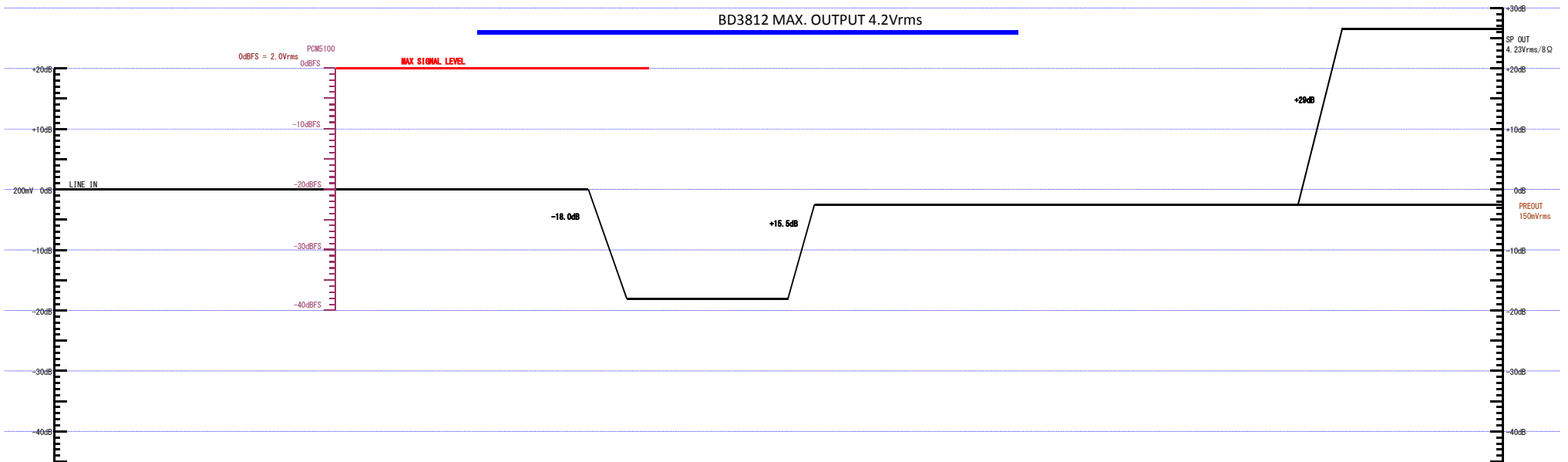
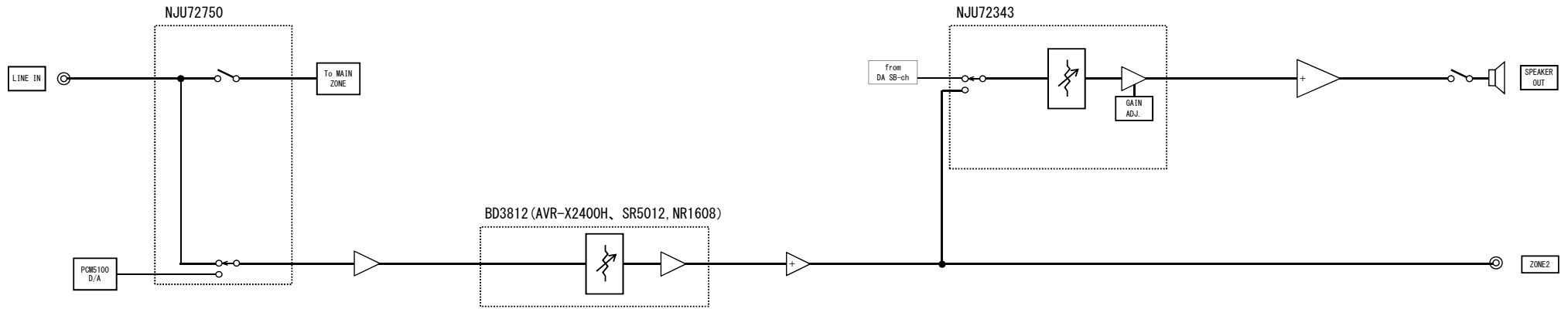

AVR-S930H/X2400H
LEVEL DIAGRAM
ZONE2(LEGO)

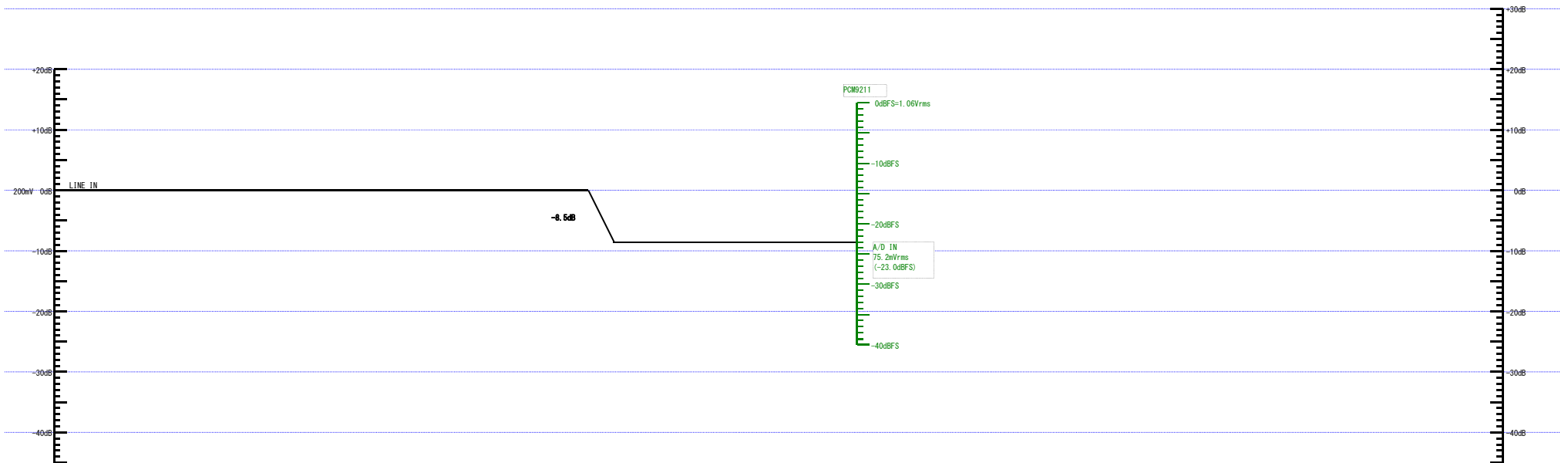
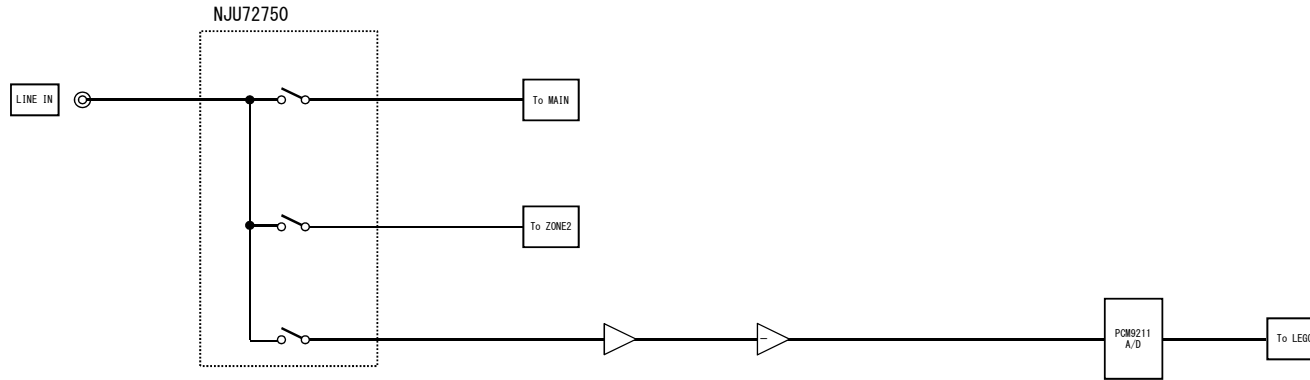

AVR_S930H / X2400H / ANALOG AUDIO DIAGRAM

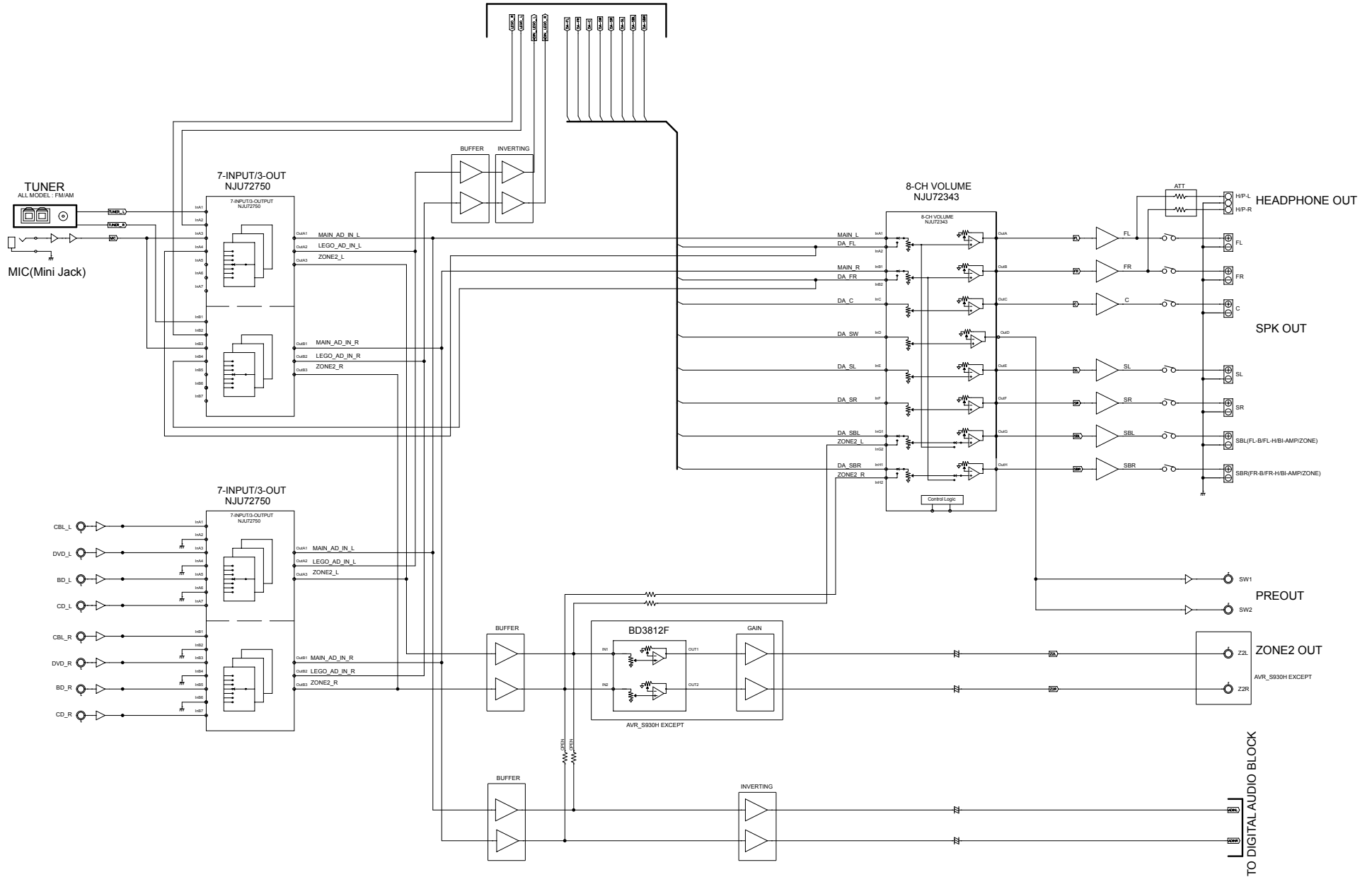

AVR_S930H / X2400H DIGITAL AUDIO DIAGRAM

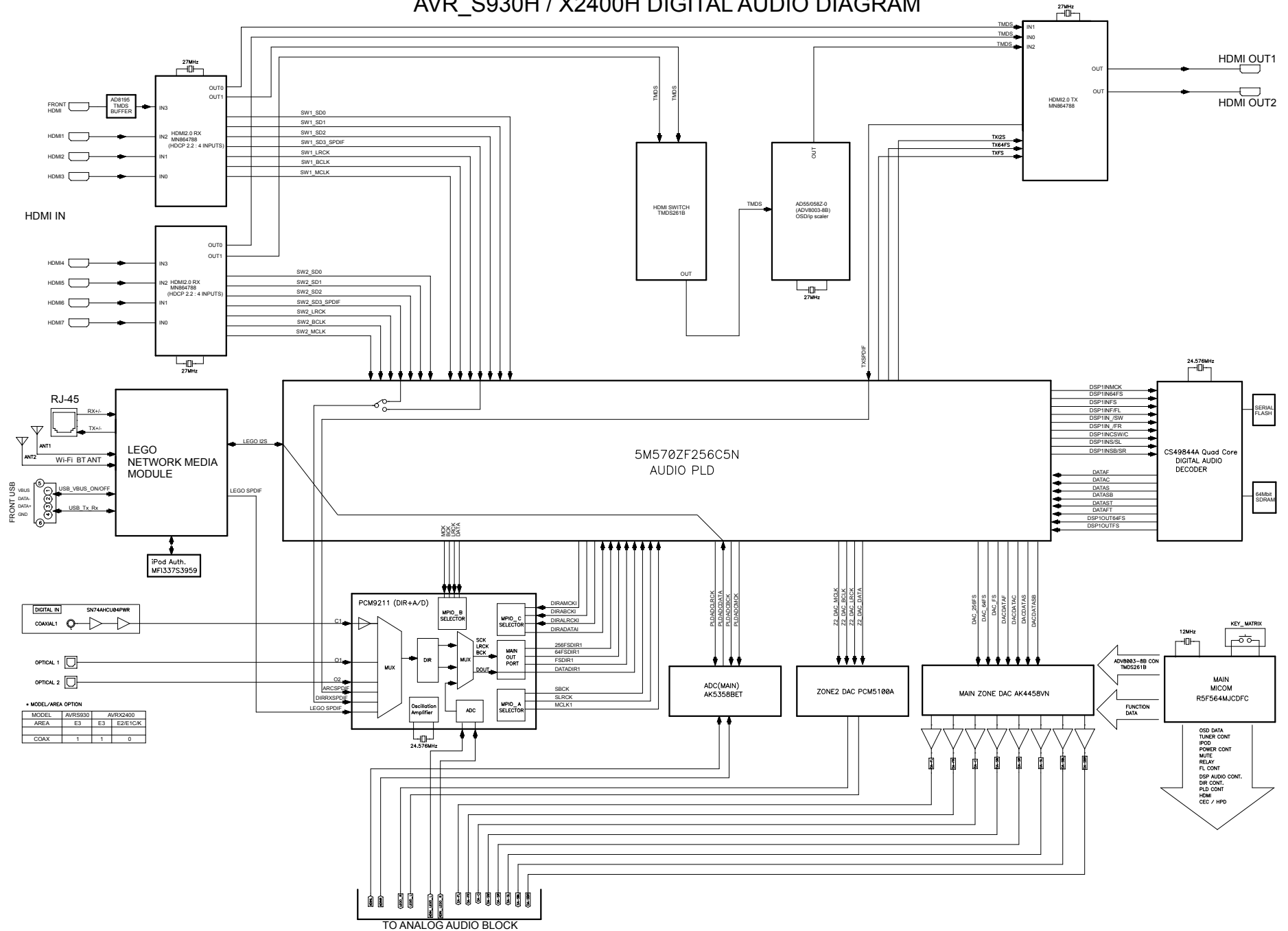

Caution in servicing

Electrical

Mechanical

Repair Information

Updating

AVR_S930H / X2400H VIDEO DIAGRAM

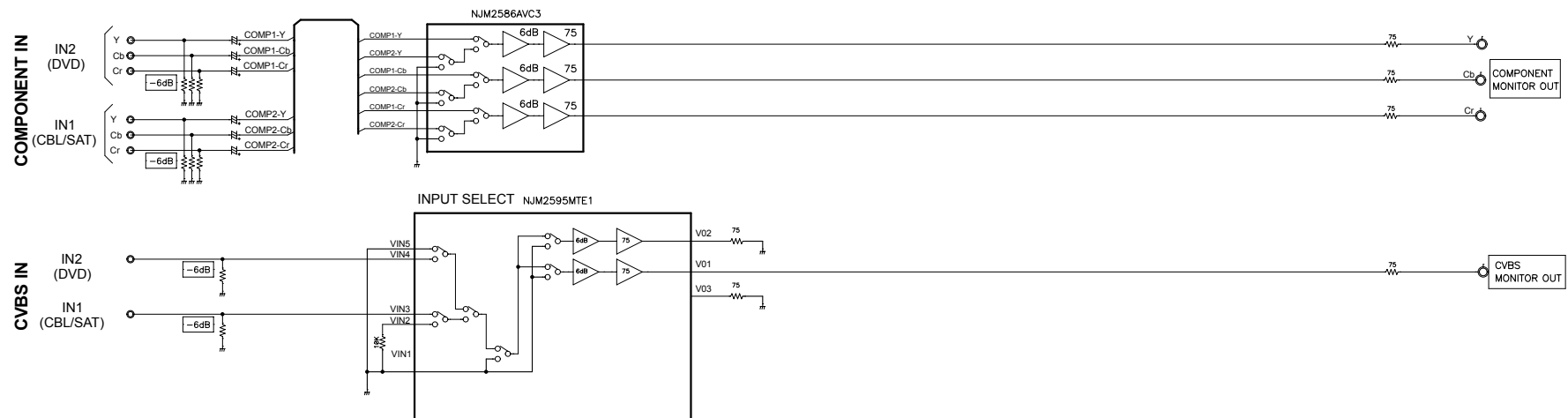
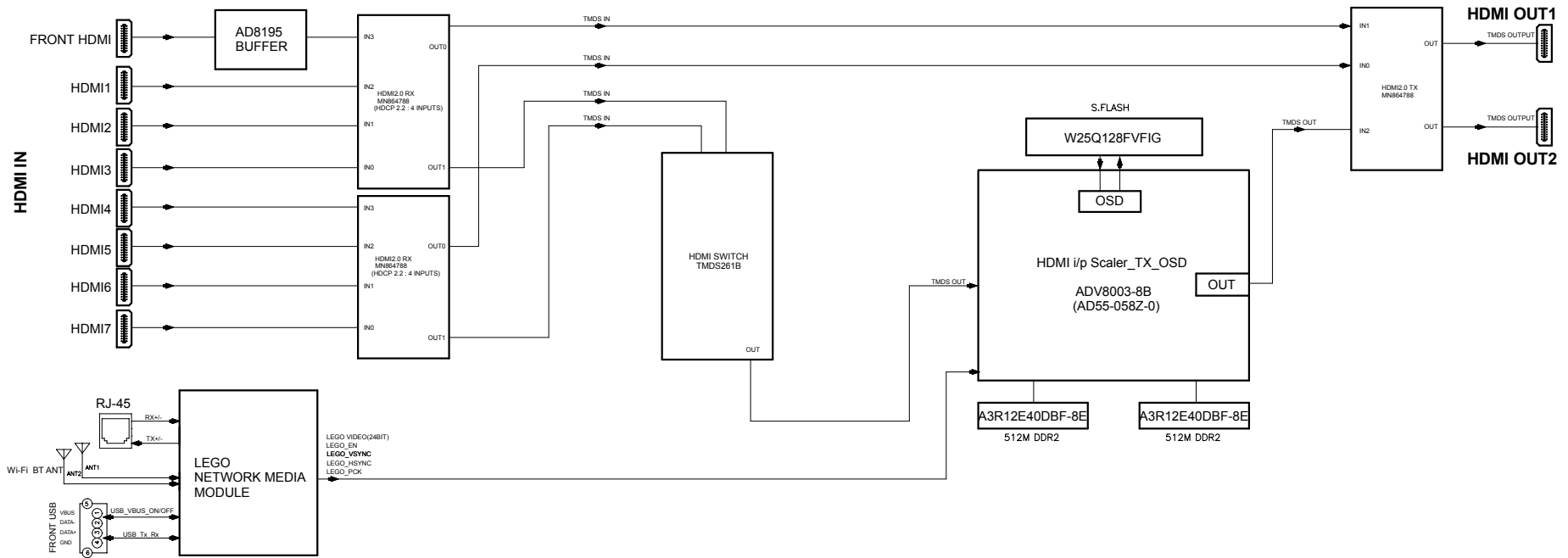

AVR_S930H / X2400H VCC DIAGRAM

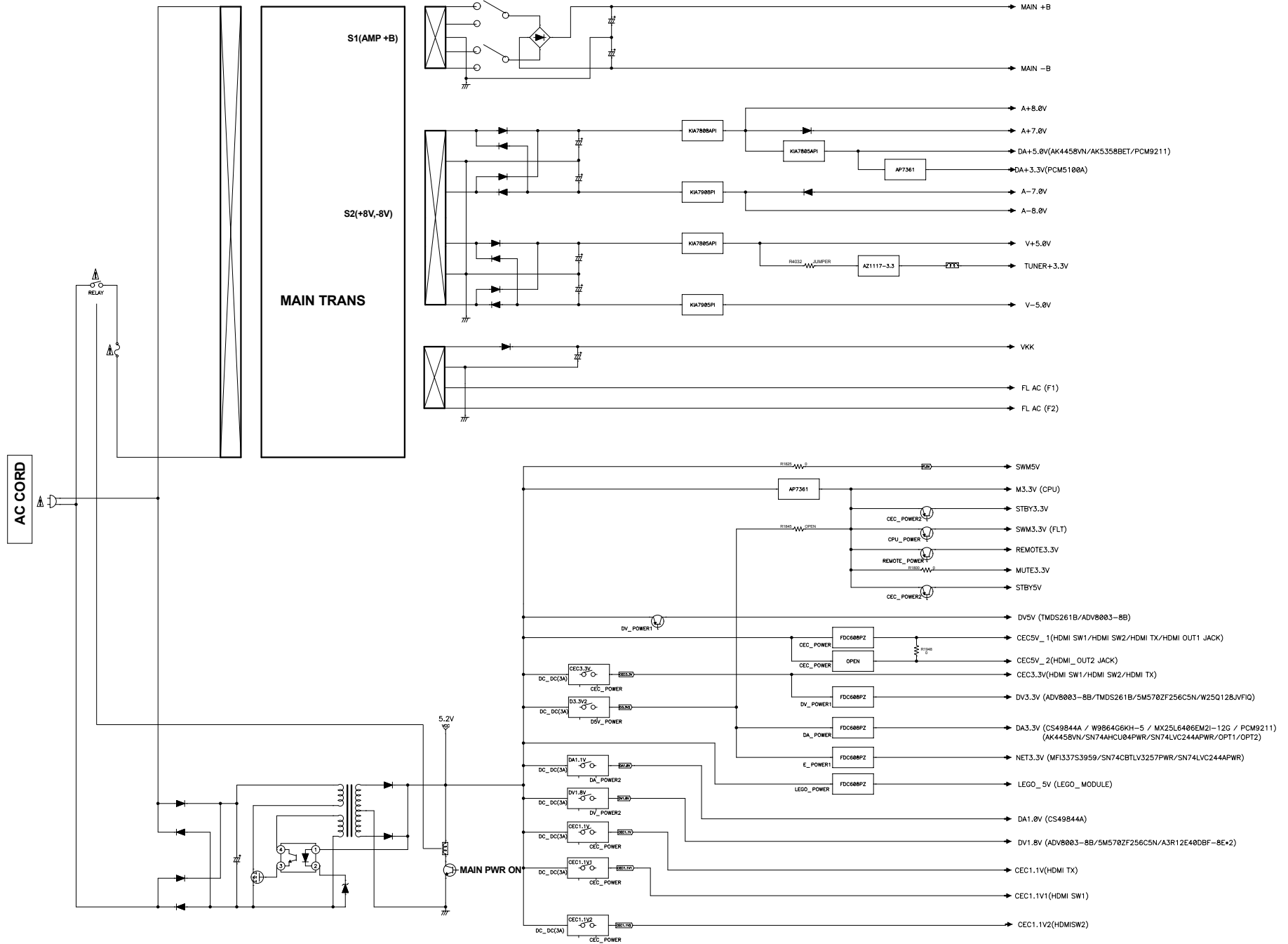

Caution in servicing

Electrical

Mechanical

Repair Information

Updating

WIRING DIAGRAM

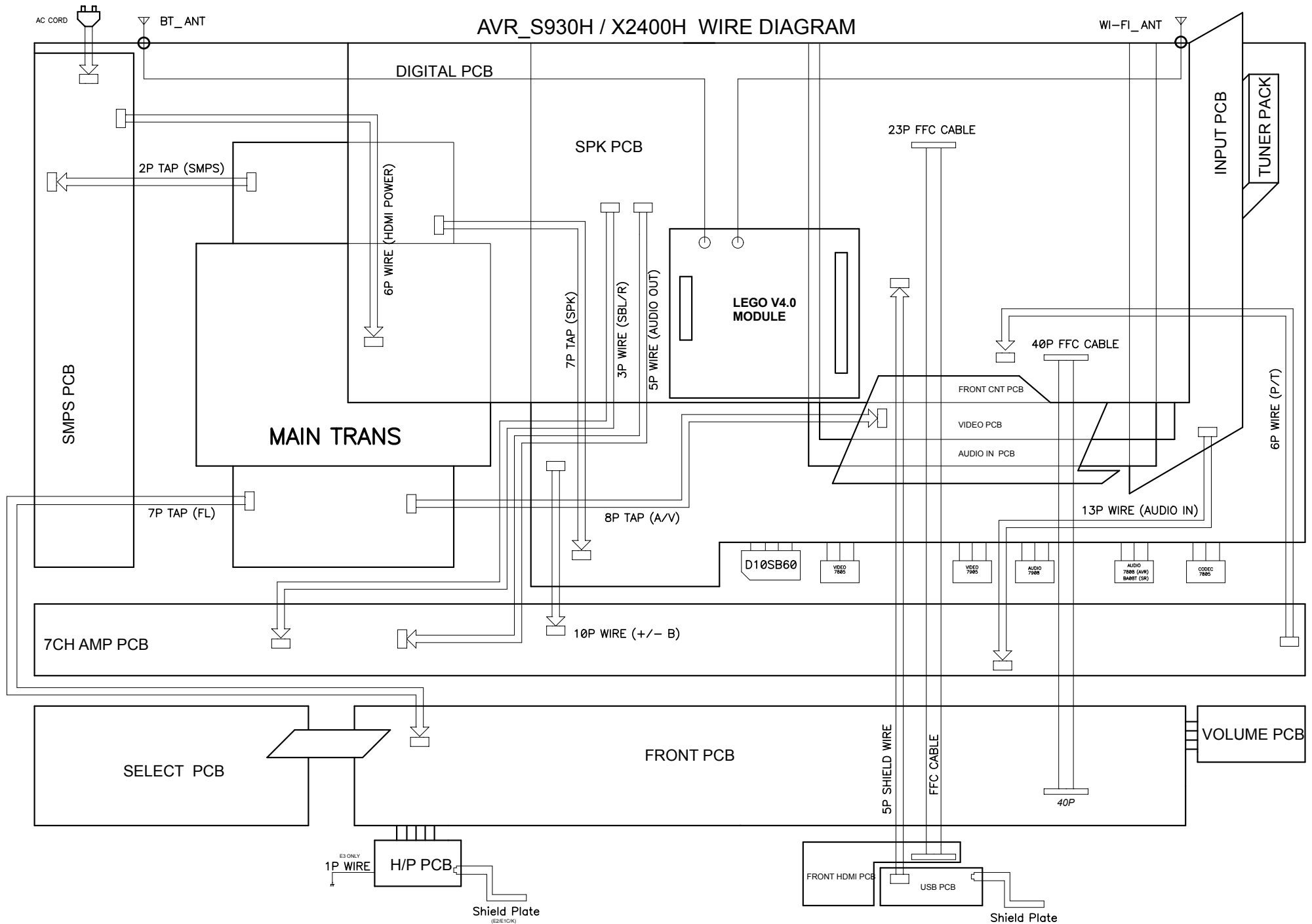

Caution in servicing

Electrical

Mechanical

Repair Information

Updating

Only major semiconductors are shown, general semiconductors etc. are omitted to list.
The semiconductor which described a detailed drawing in a schematic diagram are omitted to list.

1. IC's

R5F564MJCDFC (DIGITAL : U1018)

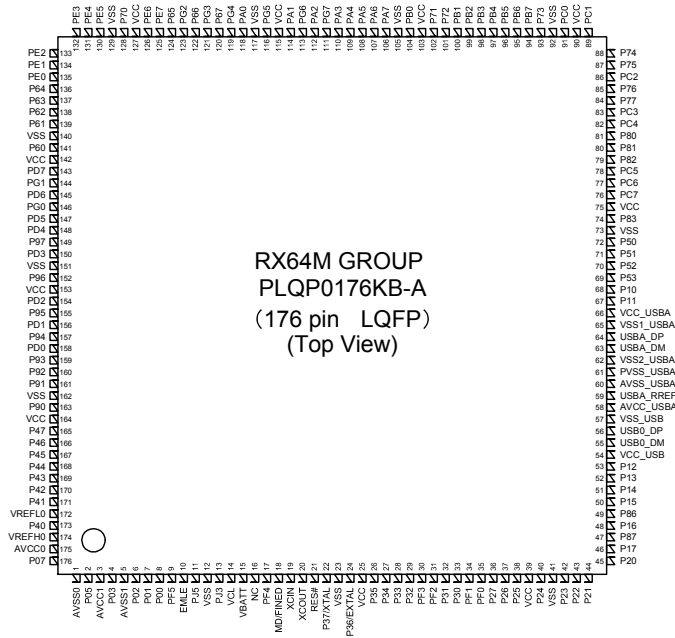

RX64M GROUP
PLQP0176KB-A
(176 pin LQFP)
(Top View)

Terminal Functions

Pin	Pin Name	Symbol	I/O	Pu/Pd	STBY	STOP	CEC STBY	Function
1	AVSS0	AVSS0	-	-	-	-	-	Ground pin
2	P05/IRQ13	POWER_KEY	I	M3VPu	I	I	I	Detect Power switch (Release from Wait Mode,Set to interrupt)
3	AVCC1	AVCC1	-	-	-	-	-	Power supply pin
4	P03/IRQ11	RED_LED	O	-	L/H	L	H	POWER/STANDBY LED control pin
5	AVSS1	AVSS1	-	-	-	-	-	Ground pin
6	P02/SCK6/IRQ10/AN120	REMOTE_POWER	O	-	L	L	L	232C power supply (REMOTE 3.3V) control pin
7	P01/RXD6/IRQ9/AN119	RXD_MI2320	I	Pd	I	I	I	External data input port (for AMX/FW update via 232C) :Connector is FFC
8	P00/TXD6/IRQ8/AN118	TXD_MO2321	O	-	L	L	L	External data output port (for AMX/FW update via 232C) :Connector is FFC
9	PF5/IRQ4	WHITE_LED (X2400(NA)) / GREEN_LED (X2400(EU/CH/JP)/S930/SR5012/NR1608)	O	-	L	L	L	POWER LED control pin
10	EMLE	EMLE	I	Pd	-	-	-	E20 Emulator control pin (On chip Emulator is used,this pin should be High. Not used,it should be Low)
11	PJ5	VSEL_A	I	SW3VPu	I	I	I	Master Volume (Rotary encoder) signal input pin

Pin	Pin Name	Symbol	I/O	Pu/Pd	STBY	STOP	CEC STBY	Function
12	VSS	VSS	-	-	-	-	-	Ground pin
13	PJ3	VSEL_B	I	SW3VPu	I	I	I	Master volume (Rotary encoder) signal input pin
14	VCL	VCL	I	-	-	-	-	Smoothing capacitor connection pin
15	VBATT	VBATT	-	-	-	-	-	Power supply pin
16	NC	NC	I	Pd	-	-	-	NC(Pull down)
17	TRST#/PF4	TRST#/NC(NORMRAL)	I/O	Pd	I/O	I/O	I/O	E20 Emulator control pin/When normal operating mode,set to input.
18	MD/FINED	MD	I	M3VPu	I	I	I	Pins for setting the operating mode(select the Boot Mode or User Boot Mode,Single Chip Mode)
19	XCIN	XCIN	I	Pd	-	-	-	NC(Pull down)
20	XCOUT	XCOUT	I	-	-	-	-	NC(open)
21	RES#	RESET	I	M3VPu	-	-	-	Reset signal input pin
22	XTAL/P37	XTAL	I	-	-	-	-	Pins for a crystal resonator (Xin=12MHz × 10)
23	VSS	VSS	-	-	-	-	-	Ground pin
24	EXTAL/P36	EXTAL	-	-	-	-	-	Pins for a crystal resonator (Xin=12MHz × 10)
25	VCC	VCC	-	-	-	-	-	Power supply pin
26	UPSEL/P35(IN)/NMI	DSP_FLAG3	I	DA3VPu	I	I	I	DSP(CS49844A) interrupt signal input pin
27	P34/SCK6/SCK0/IRQ4	BDOWN	I	M3VPu	I	I	I	Detect power down
28	P33/TIOC0/RXD6/RXD0/IRQ3-DS	RC_IN	I	Pd(S930/X2400) M3Vpu (SR5012/NR1608NR)	I	I	I	Remote input
29	P32/TIOCC0/TXD6/TXD0/IRQ2-DS	NC(S930/X2400/NR1608(EU/JP) / FLASHER_IN (NR1608(NA)/SR5012)	O/I	-/Pd	L/I	L/I	L/I	Flasher (Remote) input pin (When standby mode,set to interrupt)
30	TMS/PF3	TMS/NC(NORMRAL)	I/O	M3VPu	-/I	-/I	I	E20 Emulator control pin/When normal operating mode,set to input.
31	TDI/PF2/RXD1	TDI/RXD_MIT-SUBISHI	I/O/I	M3VPu	-/I	-/I	I	E20 Emulator control pin/Mitsubishi writer control pin/When normal operating mode,set to input.
32	P31/IRQ1-DS	TU_IISD	I	-	L	L	L	TUNER control
33	P30/RXD1	TU_DA	I/O	SW3VPu	L	L	L	TUNER control
34	TCK/FINEC/PF1/SCK1	TCK/NC(NORMRAL)	I/O/I	M3VPu	-/I	-/I	I	E20 Emulator control pin/When normal operating mode,set to input.
35	TD0/TXD1/PF0	TDO/TXD_MITSUBISHI	O/O/I	M3VPu	-/I	-/I	I	E20 Emulator control pin/Mitsubishi writer control pin/When normal operating mode,set to input.
36	P27/SCK1	TU_LA	O	-	L	L	L	TUNER control
37	P26/TXD1	TU_CK	O	SW3VPu	L	L	L	TUNER control
38	P25/RXD3	TU_IIC/RDSI	O	-	L	L	L	TUNER control
39	VCC	VCC	-	-	-	-	-	Power supply pin
40	P24/SCK3	NC(S930/X2400)/ KILL_IR(SR5012/NR1608)	O	-	L	L	L	Front IR disable control pin
41	VSS	VSS	-	-	-	-	-	Ground pin
42	P23/TXD3	E_RTS_MOEI	O	Pd (BCM58305 Internal Pd)	L	L	L	Ethernet(LEGO) control pin
43	P22/SCK0	E_CTS_MIEO	I	Pd (onboard + BCM58305 Internal Pd)	I	I	I	Ethernet(LEGO) control pin
44	P21/RXD0/IRQ9	E_RXD_MIEO	I	Pd (onboard + BCM58305 Internal Pd)	I	L	I	Ethernet(LEGO) control pin

Pin	Pin Name	Symbol	I/O	Pu/Pd	STBY	STOP	CEC STBY	Function
45	P20/TXD0/IRQ8	E_TXD_MOEI	O	Pd (BCM58305 Internal Pd)	L	L	L	Ethernet(LEGO) control pin
46	P17/SCK1/TXD3/IRQ7	NET_FACT_RST	O(ODR)	Pu (BCM58305 Internal Pu)	Z	Z	Z	Ethernet(LEGO) control pin
47	P87/TXD10/TIOCA2	NC (S930/X2400) / RC_OUT (SR5012/NR1608)	O		L/H	L/L	L/H	Remote code (RC-5) output pin
48	P16/TXD1/RXD3/IRQ6	NET5V_POWER	O		L	L	L	Ethernet power supply (Net5V) control pin/
49	P86/RXD10	PRE_Z2_MUTE(X2400/SR5012/NR1608) / NC (S930)	O		L	L	L	MUTE for ZONE2 preout control pin
50	P15/RXD1/SCK3/IRQ5	AEXP_STB	O		L	L	L	Expander (MC14094) control pin
51	P14/IRQ4	AEXP_OE	O		L	L	L	Expander (MC14094) control pin
52	P13/TXD2/IRQ3	AEXP_CLK	O		L	L	L	Expander (MC14094) control pin
53	P12/RXD2/IRQ2	AEXP_DATA	O		L	L	L	Expander (MC14094) control pin
54	VCC_USB	VCC_USB	-		-	-	-	Power supply pin
55	USB0_DM	USB0_DM	-		-	-	-	NC(open)
56	USB0_DP	USB0_DP	-		-	-	-	NC(open)
57	VSS_USB	VSS_USB	-		-	-	-	Ground pin
58	AVCC_USBA	AVCC_USBA	-		-	-	-	Power supply pin
59	USBA_PREF	USBA_PREF	-		-	-	-	NC(open)
60	AVSS_USBA	AVSS_USBA	-		-	-	-	Ground pin
61	PVSS_USBA	PVSS_USBA	-		-	-	-	Ground pin
62	VSS2_USBA	VSS2_USBA	-		-	-	-	Ground pin
63	USBA_DM	USBA_DM	-		-	-	-	NC(open)
64	USBA_DP	USBA_DP	-		-	-	-	NC(open)
65	VSS1_USBA	VSS1_USBA	-		-	-	-	Ground pin
66	VCC_USBA	VCC_USBA	-		-	-	-	Power supply pin
67	P11/SCK2/IRQ1	CEC_OUT	O		L	L	-	CEC-D control pin
68	P10/IRQ0	CEC_IN	I	STB3VPu	I	I	I	CEC-D control pin
69	P53	ADV8003_SPI_CS	O	DV3VPu	L	L	L	GUI control pin(ADV8003)
70	P52/RXD2	ADV8003_SPI_MI	I		L	L	L	GUI control pin(ADV8003)
71	P51/SCK2	ADV8003_SPI_CLK	O		L	L	L	GUI control pin(ADV8003)
72	P50/TXD2	ADV8003_SPI_MO	O		L	L	L	GUI control pin(ADV8003)
73	VSS	VSS	-		-	-	-	Ground pin
74	P83/SCK10	IP_RST	O	Pd	I	I	L	Scaler w/ GUI (ADV8003) Reset control pin
75	VCC	VCC	-		-	-	-	Power supply pin
76	UB/PC7/TXD8/IRQ14	UB	I	Pd	-	-	-	Pins for setting the boot mode(select the Boot Mode or User Boot Mode)
77	PC6/RXD8/IRQ13	AVSDA	I_O	DV3VPu	O/L	O/L	L	VIDEO I2C control pin for ADV8003/ ADV7180(except X2400/S930)
78	PC5/SCK8	AVSCL	I_O	DV3VPu	O/L	O/L	L	VIDEO I2C control pin for ADV8003/ ADV7180(except X2400/S930)
79	P82/TXD10	DSP_MOSI	O	DA3VPu	L	L	L	DSP(CS49844A) control pin
80	P81/RXD10	DSP_MISO	I	DA3VPu	L	L	L	DSP(CS49844A) control pin
81	P80/SCK10	DSP_CLK	O	DA3VPu	L	L	L	DSP(CS49844A) control pin
82	PC4/SCK5	DSP_CS	O	DA3VPu	L	L	L	DSP(CS49844A) control pin
83	PC3/TXD5	DSP_FLAG0	I	DA3VPu	L	L	L	DSP(CS49844A) interrupt signal input pin
84	P77/TXD11	DSP_RST	O	Pd	L	L	L	DSP(CS49844A) reset control pin
85	P76/RXD11	DSP_BUSY	I	DA3VPu	L	L	L	DSP BUSY signal input
86	PC2/RXD5	DA_POWER	O		L	L	L	Digital audio power supply (DA3.3V,DA1.2V) control pin

Pin	Pin Name	Symbol	I/O	Pu/Pd	STBY	STOP	CEC STBY	Function
87	P75/SCK11	CEC_POWER2	O		L	L	L	CEC standby power control (for CEC Standby Mode 3)
88	P74	SEL_DATA	O		L	L	L	Audio selector control pin for NJU72750/ 72751(SR5012)
89	PC1/SCK5/IRQ12	DAC_PLD_ERR	I		L	L	L	Detect PLD error (from Audio PLD)
90	VCC	VCC	-		-	-	-	Power supply pin
91	PC0/IRQ14	H/P_RL	O		L	L	L	Headphone relay control pin
92	VSS	VSS	-		-	-	-	Ground pin
93	P73	FRONT_RL	O		L	L	L	Speaker relay control pin
94	PB7/TXD9	HSDA	I/O	CEC3VPu	L	L	L	HDMI I2C control pin for MN864788
95	PB6/RXD9	HSDL	I/O	CEC3VPu	L	L	L	HDMI I2C control pin for MN864788
96	PB5/SCK9	SEL_CLK	O		L	L	L	Audio selector control pin for NJU72750/ 72751(SR5012)
97	PB4	APLD_CS	O		L	L	L	Audio PLD (5M570ZF256C5N) control pin
98	PB3/SCK4/SCK6	APLD_DATA/DAC_DATA	O		L	L	L	Audio PLD (5M570ZF256C5N) control pin/DAC (AK4458VN) control pin
99	PB2	APLD_CLK/DAC_CLK	O		L	L	L	Audio PLD (5M570ZF256C5N) control pin/DAC (AK4458VN) control pin
100	PB1/TXD4/TXD6/IRQ4-DS	DAC_MS	O		L	L	L	DAC (AK4458VN) control pin
101	P72	DAC_RST	O		L	L	L	DAC (AK4458VN) control pin
102	P71	PRE_MUTE	O		L	L	L	MUTE for preout control pin
103	VCC	VCC	-		-	-	-	Power supply pin
104	PB0/RXD4/RXD6/IRQ12	DA_POWER2	O		L	L	L	Digital audio power supply (DA1.0V) control pin
105	VSS	VSS	-		-	-	-	Ground pin
106	PA7	ISEL_A	I	SW3VPu	I	I	I	Input selector (Rotary encoder) signal input pin
107	PA6	ISEL_B	I	SW3VPu	I	I	I	Input selector (Rotary encoder) signal input pin
108	PA5	C/S_RL	O		L	L	L	Speaker relay control pin
109	PA4/TXD5/SSDA5/IRQ5-DS	DSP_ROM_WRITE	O		L	L	L	DSP ROM writing control(When writing,set to High)
110	PA3/RXD5/SSCL5	MVOL_MUTE	O		L	L	L	Volume control pin (NJU72343)
111	TRDATA3/PG7	MVOL_CLK	O		L	L	L	Volume control pin (NJU72343)
112	PA2/RXD5	MVOL_DATA	O		L	L	L	Volume control pin (NJU72343)
113	TRDATA2/PG6	ZVOL_DATA (X2400/NR1608/SR5012) / NC (S930)	O		L	L	L	ZONE2 volume control pin (BD3812F)
114	PA1/SCK5/IRQ11	ZVOL_CLK (X2400/NR1608/SR5012) / NC (S930)	O		L	L	L	ZONE2 volume control pin (BD3812F)
115	VCC	VCC	-		-	-	-	Power supply pin
116	TRCLK/PG5	ZVOL_MUTE (X2400/NR1608/SR5012) / NC (S930)	O		L	L	L	ZONE2 volume control pin (BD3812F)
117	VSS	VSS	-		-	-	-	Ground pin
118	PA0	H5V_DET	I		L	L	L	HDMI IN 5V detect signal pin
119	TRSYNC/PG4	FL_RST	O		L	L	L	FL display control pin
120	P67/IRQ15	FL_CE	O		L	L	L	FL display control pin
121	TRDATA1/PG3	FL_CLK	O		L	L	L	FL display control pin
122	P66	FL_DATA	O		L	L	L	FL display control pin
123	TRDATA0/PG2	SB_RL	O		L	L	L	Speaker relay control pin
124	P65	CPU_POWER_2 (S930/X2400/NR1608) / FIL_CTRL (SR5012)	O		L	L	L	CPU power supply control pin(same as 131pin) / Filament Power control pin (for Portal FLD)
125	PE7/IRQ7/AN105	ASO/DC_DET	I	SW3VPu	I	L	I	Protection detect signal input pin (for ASO and DC) (A/D converter)

Pin	Pin Name	Symbol	I/O	Pu/Pd	STBY	STOP	CEC STBY	Function
126	PE6/IRQ6/AN104	MIC_DET/H/ P_DET	I	SW3VPu	I	L	I	Headphone insert detect pin/Microphone insert detect pin (A/D converter)
127	VCC	VCC	-	-	-	-	-	Power supply pin
128	P70	HIGH_B_RL	O	-	L	L	L	HIGH-B relay control pin
129	VSS	VSS	-	-	-	-	-	Ground pin
130	PE5/IRQ5/AN103	MAIN_POWER	O	-	L	L	L	Power supply control pin
131	PE4/AN102	CPU_POWER	O	-	L	L	L	CPU power supply control pin
132	PE3/AN101	AIOS4_WAKE- UP	O	-	L	L	L	same as NET5V_POWER,NET3.3V_POWER (This port use to control for LEGO standby mode in the future(Low : Deep Standby, High : normal))
133	PE2/RXD12/IRQ7- DS/AN100	AIOS4_STBY_ STATUS	I	Pd	I	I	I	Not used (This port use to detect for LEGO standby status in the future (Low : normal, High : Deep Standby))
134	PE1/TXD12	GUI_WRITE	O	-	L	L	L	GUI flash rom writing control
135	PE0/SCK12	NET3.3V_ POWER	O	-	L	L	L	Ethernet power supply control(Net3.3V)
136	P64	D5V_POWER	O	-	L	L	H	Digital 5V power supply control pin(3.3V and 1.8V generate from 5V)
137	P63	CEC_POWER	O	-	L	L	-	CEC standby power supply control(CEC5V,CEC3.3V,CEC1.8V)
138	P62	DV_POWER1	O	-	L	L	L	Digital video power supply (DV5V,DV3.3V) control pin
139	P61	DV_POWER2	O	-	L	L	L	Digital video power supply (DV1.8V) control pin
140	VSS	VSS	-	-	-	-	-	Ground pin
141	P60	DIR_DIN	O	-	L	L	L	DIR (PCM9211) control pin
142	VCC	VCC	-	-	-	-	-	Power supply pin
143	PD7/IRQ7/AN107	DIR_CE	O	-	L	L	L	DIR (PCM9211) control pin
144	PG1	DIR_DOUT	I	DA3.3Pu	I	I	I	DIR (PCM9211) control pin
145	PD6/IRQ6/AN106	DIR_CLK	O	-	L	L	L	DIR (PCM9211) control pin
146	PG0	DIR_RST	O	-	L	L	L	DIR (PCM9211) control pin
147	PD5/IRQ5/AN113	788_2_HAINT	I	CEC3VPu	Z	-	-	HDMI Rx (MN864788) audio interrupt signal det
148	PD4/IRQ4/AN112	SW_SDA	I/O	DV3VPu	O/L	O/L	L	HDMI TMDS switch I2C ccontrol pin for TMDS261B
149	P97	DE_RST (NR1608/ SR5012) / NC (X2400/S930)	O	Pd	Z	-	L	Video decoder (ADV7180) reset control pin
150	PD3/IRQ3/AN111	788_1_HINT	I	CEC3VPu	Z	-	-	HDMI Tx (MN864788) interrupt signal input pin
151	VSS	VSS	-	-	-	-	-	Ground pin
152	P96	788_1_RST	O	Pd	Z	-	-	HDMI Tx (MN864788) reset control pin
153	VCC	VCC	-	-	-	-	-	Power supply pin
154	PD2/IRQ2/AN110	788_2_HINT	I	CEC3VPu	Z	-	-	HDMI Rx (MN864788) interrupt signal input pin
155	P95	788_2_RST	O	Pd	Z	-	-	HDMI Rx (MN864788) reset control pin
156	PD1/IRQ1/AN109	788_3_HINT	I	CEC3VPu	Z	-	-	HDMI Rx (MN864788) interrupt signal input pin
157	P94	788_3_RST	O	Pd	Z	-	-	HDMI Rx (MN864788) reset control pin
158	PD0/IRQ0/AN108	A_TO_H/ NET (SR5012/ NR1608)/ NC (S930/X2400)	O	-	L	L	L	Video PLD control pin (Net GUI:High,A to H:Low)
159	P93/AN117	THERMAL_A	I	SW3VPu	I	L	I	Protection detect signal input pin (for power TR)
160	P92/RXD7/AN116	THERMAL_B	I	SW3VPu	I	L	I	Protection detect signal input pin (for power TR)
161	P91/AN115	SW_SCL	I/O	DV3VPu	O/L	O/L	L	HDMI TMDS switch I2C control pin for TMDS261B
162	VSS	VSS	-	-	-	-	-	Ground pin
163	P90/TXD7/AN114	THERMAL_E	I	SW3VPu	I	L	I	Protection detect signal input pin (for Heat sink)
164	VCC	VCC	-	-	-	-	-	Power supply pin
165	P47/IRQ15-DS/ AN007	788_3_HAINT	I	CEC3VPu	Z	-	-	HDMI Rx (MN864788) audio interrupt signal det
166	P46/IRQ14-DS/ AN006	CURRENT_DET	I/O	Pd	I/L	L/L	I/L	Current level monitor pin (A/D converter)
167	P45/IRQ13-DS/ AN005	AMPSIGDET	I	Pd	I	L	I	Signal level monitor pin (AD converter)
168	P44/IRQ12-DS/ AN004	MODE	I	-	I	I	I	Region setting pin

Pin	Pin Name	Symbol	I/O	Pu/Pd	STBY	STOP	CEC STBY	Function
169	P43/IRQ11-DS/ AN003	KEY3	I	M3VPu	I	I	I	Key control signalinput pin (When standby mode,set to inturrupt)
170	P42/IRQ10-DS/ AN002	KEY2	I	M3VPu	I	I	I	Key control signalinput pin (When standby mode,set to inturrupt)
171	P41/IRQ9-DS/ AN001	KEY1	I	M3VPu	I	I	I	Key control signalinput pin (When standby mode,set to inturrupt)
172	VREFL0	VREFL0	-	-	-	-	-	Ground pin
173	P40	ADC_RST	O	-	I	L	I	A/D convertor(AK5358) reset control pin
174	VREFH0	VREFH0	-	-	-	-	-	Power supply pin
175	AVCC0	AVCC0	-	-	-	-	-	Power supply pin
176	P07/IRQ15	COMP_DET (SR5012/ NR1608)/ NC (S930/X2400)	I	SW3VPu	I	I	I	Component video signal detect pin

AD8195ACPZ (F_HDMI : U3000)

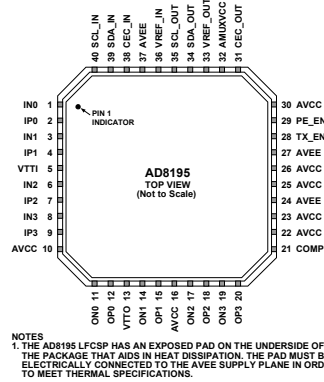

Terminl Function

Pin No.	Mnemonic	Type ¹	Description
1	IN0	HS I	High Speed Input Complement.
2	IP0	HS I	High Speed Input.
3	IN1	HS I	High Speed Input Complement.
4	IP1	HS I	High Speed Input.
5	VTTI	Power	Input Termination Supply. Nominally connected to AVCC.
6	IN2	HS I	High Speed Input Complement.
7	IP2	HS I	High Speed Input.
8	IN3	HS I	High Speed Input Complement.
9	IP3	HS I	High Speed Input.
10, 16, 22, 23, 25, 26, 30	AVCC	Power	Positive Analog Supply, 3.3 V nominal.
11	ON0	HS O	High Speed Output Complement.
12	OP0	HS O	High Speed Output.
13	VTTO	Power	Output Termination Supply. Nominally connected to AVCC.
14	ON1	HS O	High Speed Output Complement.
15	OP1	HS O	High Speed Output.
17	ON2	HS O	High Speed Output Complement.
18	OP2	HS O	High Speed Output.
19	ON3	HS O	High Speed Output Complement.
20	OP3	HS O	High Speed Output.
21	COMP	Control	Power-On Compensation Pin. Bypass to ground through a 10 µF capacitor.
24, 27, 37, Exposed Pad	AVEE	Power	Negative Analog Supply, 0 V nominal.
28	TX_EN	Control	High Speed Output Enable Parallel Interface.
29	PE_EN	Control	High Speed Preemphasis Enable Parallel Interface.
31	CEC_OUT	LS I/O	CEC Output Side.
32	AMUXVCC	Power	Positive Auxiliary Buffer Supply, 5 V nominal.

Block diagram

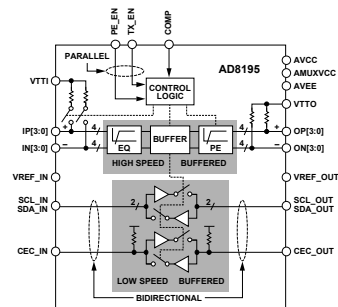

PCM9211 (DIGITAL : U1040)

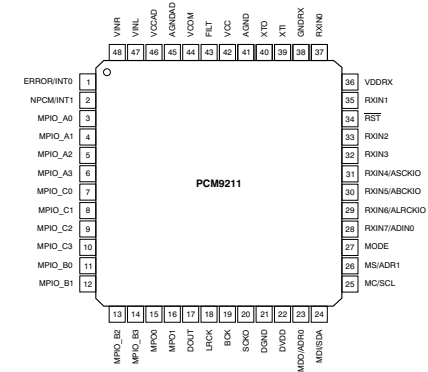

PIN Functions

PIN				DESCRIPTION
NO.	NAME	I/O	5-V TOLERANT	
1	ERROR/INT0	O	No	DIR Error detection output / Interrupt0 output
2	NPCM/INT1	O	No	DIR Non-PCM detection output / Interrupt1 output
3	MPIO_A0	I/O	Yes	Multipurpose I/O, Group A(1)
4	MPIO_A1	I/O	Yes	Multipurpose I/O, Group A(1)
5	MPIO_A2	I/O	Yes	Multipurpose I/O, Group A(1)
6	MPIO_A3	I/O	Yes	Multipurpose I/O, Group A(1)
7	MPIO_C0	I/O	Yes	Multipurpose I/O, Group C(1)
8	MPIO_C1	I/O	Yes	Multipurpose I/O, Group C(1)
9	MPIO_C2	I/O	Yes	Multipurpose I/O, Group C(1)
10	MPIO_C3	I/O	Yes	Multipurpose I/O, Group C(1)
11	MPIO_B0	I/O	Yes	Multipurpose I/O, Group B(1)
12	MPIO_B1	I/O	Yes	Multipurpose I/O, Group B(1)
13	MPIO_B2	I/O	Yes	Multipurpose I/O, Group B(1)
14	MPIO_B3	I/O	Yes	Multipurpose I/O, Group B(1)
15	MPO0	O	No	Multipurpose output 0
16	MPO1	O	No	Multipurpose output 1
17	DOU	O	No	Main output port, serial digital audio data output
18	LRCK	O	No	Main output port, LR clock output
19	BCK	O	No	Main output port, Bit clock output
20	SCKO_OUT	O	No	Main output port, System clock output
21	DGND	-	-	Ground, for digital
22	DVDD	-	-	Power supply, 3.3 V (typ.), for digital
23	MDO/ADR0	I/O	Yes	Software control I/F, SPI data output / I2C slave address setting0(2)
24	MDI/SDA	I/O	Yes	Software control I/F, SPI data input / I2C data input/output(2)(3)
25	MC/SCL	I	Yes	Software control I/F, SPI clock input / I2C clock input(2)

PIN				DESCRIPTION
NO.	NAME	I/O	5-V TOLERANT	
26	MS/ADR1	I	Yes	Software control I/F, SPI chip select / I2C slave address setting ¹⁽²⁾
27	MODE	I	No	Control mode setting. (see the Serial Control Mode section, Control Mode Pin Setting)
28	RXIN7/ADIN0	I	Yes	Biphase signal, input 7 / AUXIN0, serial audio data input ²⁾
29	RXIN6/ALRCKI0	I	Yes	Biphase signal, input 6 / AUXIN0, LR clock input ²⁾
30	RXIN5/ABCKI0	I	Yes	Biphase signal, input 5 / AUXIN0, bit clock input ²⁾
31	RXIN4/ASCKI0	I	Yes	Biphase signal, input 4 / AUXIN0, system clock input ²⁾
32	RXIN3	I	Yes	Biphase signal, input 3 ²⁾
33	RXIN2	I	Yes	Biphase signal, input 2 ²⁾
34	RST	I	Yes	Reset Input, active low ²⁾ (4)
35	RXIN1	I	Yes	Biphase signal, input 1, built-in coaxial amplifier
36	VDDR _X	-	-	Power supply, 3.3 V (typ.), for RXIN0 and RXIN1.
37	RXIN0	I	Yes	Biphase signal, input 0, built-in coaxial amplifier
38	GNDR _X	-	-	Ground, for RXIN
39	XTI	I	No	Oscillation circuit input for crystal resonator or external XTI clock source input ⁵⁾
40	XTO	O	No	Oscillation circuit output for crystal resonator
41	AGND	-	-	Ground, for PLL analog
42	VCC	-	-	Power supply, 3.3 V (typ.), for PLL analog
43	FILT	O	No	External PLL loop filter connection terminal; must connect recommended filter
44	VCOM	O	No	ADC common voltage output; must connect external decoupling capacitor
45	AGNDAD	-	-	Ground, for ADC analog
46	VCCAD	-	-	Power supply, 5.0 V (typ.), for ADC analog
47	VINL	I	No	ADC analog voltage input, left channel
48	VINR	I	No	ADC analog voltage input, right channel

- (1) Schmitt trigger input
- (2) Schmitt trigger input
- (3) Open-drain configuration in I2C mode
- (4) Onboard pull-down resistor (50 k Ω , typical)
- (5) CMOS Schmitt trigger input

BLOCK DIAGRAM

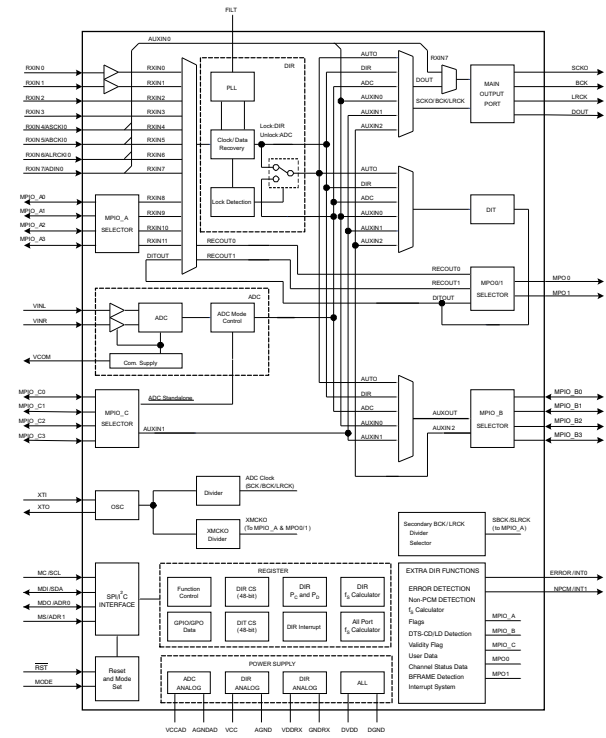

CS49844A (DIGITAL : U1073)

W9864G6KH-5 (DIGITAL : U1023)

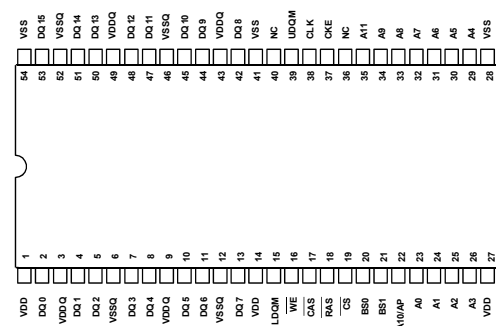
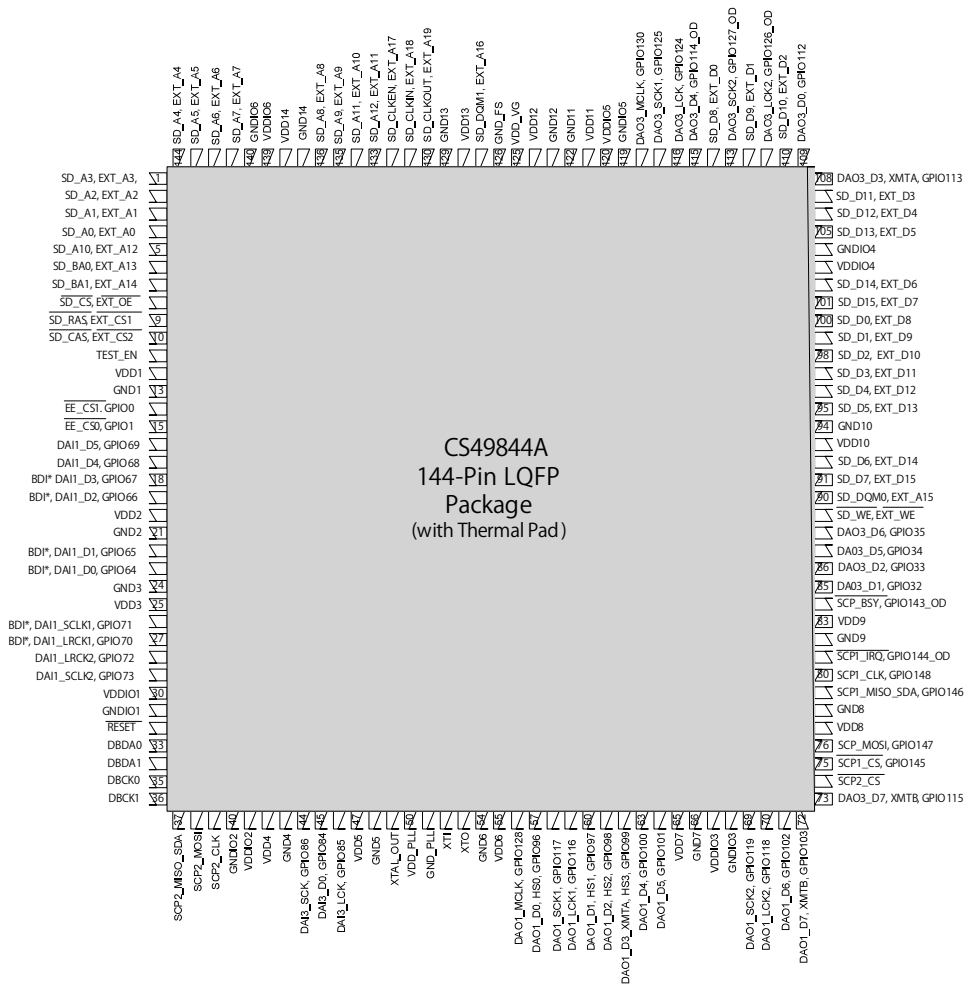

PIN NUMBER	PIN NAME	FUNCTION	DESCRIPTION
23 ~ 26, 22, 29 ~ 35	A0-A11	Address	Multiplexed pins for row and column address. Row address: A0-A11. Column address: A0-A7. A10 is sampled during a precharge command to determine if all banks are to be precharged or bank selected by BS0, BS1.
20, 21	BS0, BS1	Bank Select	Select bank to activate during row address latch time, or bank to read/write during address latch time.
2, 4, 5, 7, 8, 10, 11, 13, 42, 44, 45, 47, 48, 50, 51, 53	DQ0-DQ15	Data Input/ Output	Multiplexed pins for data output and input.
19	CS	Chip Select	Disable or enable the command decoder. When command decoder is disabled, new command is ignored and previous operation continues.
18	RAS	Row Address Strobe	Command input. When sampled at the rising edge of the clock RAS, CAS and WE define the operation to be executed.
17	CAS	Column Address Strobe	Referred to RAS
16	WE	Write Enable	Referred to RAS
39, 15	UDQM LDQM	Input/output mask	The output buffer is placed at Hi-Z (with latency of 2) when DQM is sampled high in read cycle. In write cycle, sampling DQM high will block the write operation with zero latency.
38	CLK	Clock Inputs	System clock used to sample inputs on the rising edge of clock.
37	CKE	Clock Enable	CKE controls the clock activation and deactivation. When CKE is low, Power Down mode, Suspend mode, or Self Refresh mode is entered.
1, 14, 27	VDD	Power	Power for input buffers and logic circuit inside DRAM.
28, 41, 54	VSS	Ground	Ground for input buffers and logic circuit inside DRAM.
3, 9, 43, 49	VDDQ	Power for I/O buffer	Separated power from VDD, to improve DQ noise immunity.
6, 12, 46, 52	VSSQ	Ground for I/O buffer	Separated ground from VSS, to improve DQ noise immunity.
36, 40	NC	No Connection	No connection.

Caution in Servicing

Electrical

Mechanical

Repair Information

Updating

Block diagram

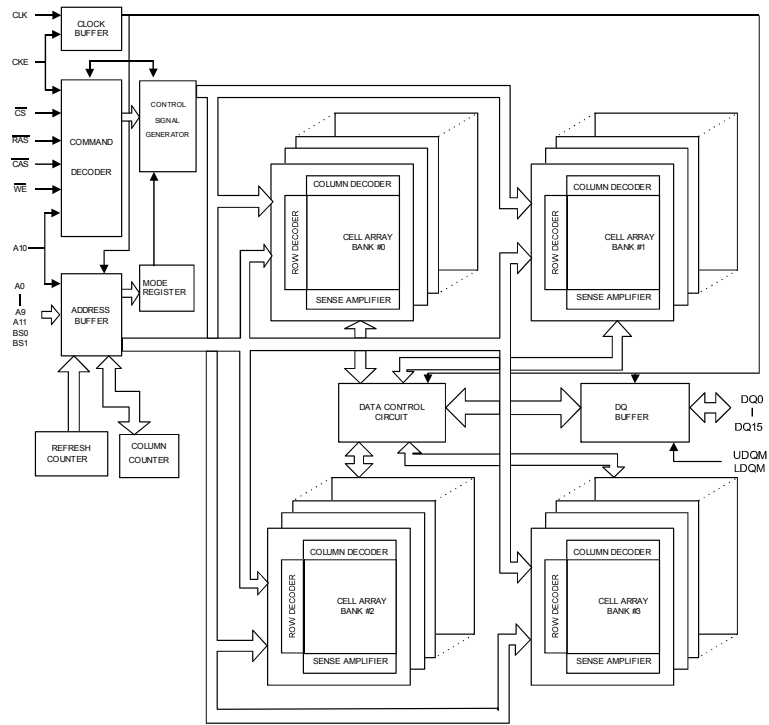

AK4458VN (DIGITAL : U1051)

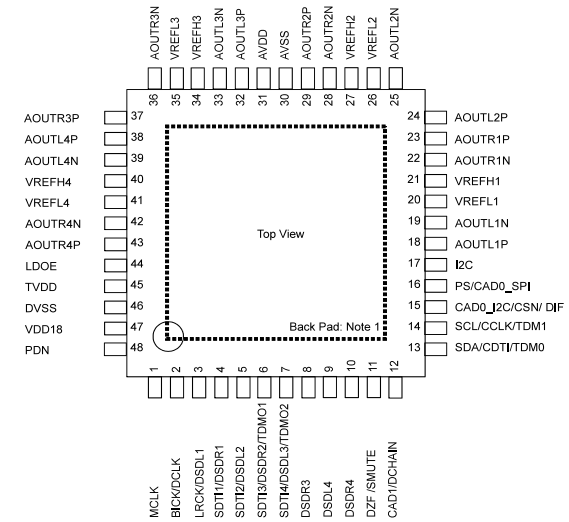

Pin Function

No.	Pin Name	I/O	Function	PD State
1	MCLK	I	External Master Clock Input Pin	Hi-Z
2	BICK	I	Audio Serial Data Clock Pin in PCM mode	Hi-z
	DCLK	I	DSD Clock Pin in DSD mode	Hi-Z
3	LRCK	I	Input Channel Clock Pin in PCM mode	Hi-Z
	DSDL1	I	Audio Serial Data Input in DSD mode	Hi-Z
4	SDTI1	I	Audio Serial Data Input in PCM mode	Hi-Z
	DSDR1	I	Audio Serial Data Input in DSD mode	Hi-Z
5	SDTI2	I	Audio Serial Data Input in PCM mode	Hi-Z
	DSDL2	I	Audio Serial Data Input in DSD mode	Hi-Z
6	SDTI3	I	Audio Serial Data Input in PCM mode	100k Ω
	DSDR2	I	Audio Serial Data Input in DSD mode	Pull down
	TDM01	O	Audio Serial Data Output in Daisy Chain mode	
	SDTI4	I	Audio Serial Data Input in PCM mode	100k Ω
7	DSDL3	I	Audio Serial Data Input in DSD mode	Pull down
	TDM02	O	Audio Serial Data Output in Daisy Chain mode	
8	DSDR3	I	Audio Serial Data Input in DSD mode	Hi-Z
9	DSDL4	I	Audio Serial Data Input in DSD mode	Hi-Z
10	DSDR4	I	Audio Serial Data Input in DSD mode	Hi-Z
	DZF	O	Zero Input Detect in I2C Bus or 3-wire serial control mode	
11	SMUTE	I	Soft Mute Pin in Parallel control mode. When this pin is changed to "H", soft mute cycle is initiated. When it is returning to "L", the output mute is released.	100k Ω
	CAD1	I	Chip Address 0 Pin in I2C Bus or 3-wire serial control mode	Pull down
12	DCHAIN	I	Daisy Chain Mode select pin in Parallel control mode.	Hi-Z
	SDA	I/O	Control Data Pin in I2C Bus serial control mode	
	CDTI	I	Control Data Input Pin in 3-wire serial control mode	Hi-Z
	TDM0	I	TDM Mode select pin in Parallel control mode.	
	SCL	I	Control Data Clock Pin in I2C Bus serial control mode	
14	CCLK	I	Control Data Clock Pin in 3-wire serial control mode	Hi-Z
	TDM1	I	TDM Mode select pin in Parallel control mode.	

No.	Pin Name	I/O	Function	PD State
15	CAD0_I2C	I	Chip Address 0 Pin in I2C Bus serial control mode	Hi-Z
	CSN	I	Chip Select Pin in 3-wire serial control mode	
	DIF	I	Audio Data Format Select in Parallel control mode. "L": 32-bit MSB, "H": 32-bit I2S	
16	PS	I	(I2C pin = "H") Control Mode Select Pin "L": I2C Bus serial control mode, "H": Parallel control mode.	Hi-Z
	CAD0_SPI	I	(I2C pin = "L") Chip Address 0 Pin in 3-wire serial control mode	
17	I2C	I	Control Mode Select Pin "L": 3-wire serial control mode "H": I2C Bus serial control mode or Parallel control mode.	Hi-Z
18	AOUTL1P	O	Lch Positive Analog Output 1 Pin	Hi-Z
19	AOUTL1N	O	Lch Negative Analog Output 1 Pin	Hi-Z
20	VREFL1	I	Negative Voltage Reference Input Pin, AVSS	Hi-Z
21	VREFH1	I	Positive Voltage Reference Input Pin, AVDD	Hi-Z
22	AOUTR1N	O	Rch Negative Analog Output 1 Pin	Hi-Z
23	AOUTR1P	O	Rch Positive Analog Output 1 Pin	Hi-Z
24	AOUTL2P	O	Lch Positive Analog Output 2 Pin	Hi-Z
25	AOUTL2N	O	Lch Negative Analog Output 2 Pin	Hi-Z
26	VREFL2	I	Negative Voltage Reference Input Pin, AVSS	Hi-Z
27	VREFH2	I	Positive Voltage Reference Input Pin, AVDD	Hi-Z
28	AOUTR2N	O	Rch Negative Analog Output 2 Pin	Hi-Z
29	AOUTR2P	O	Rch Positive Analog Output 2 Pin	Hi-Z
30	AVSS	-	Analog Ground Pin	—
31	AVDD	-	Analog Power Supply Pin, 3.0V-5.5V	—
32	AOUTL3P	O	Lch Positive Analog Output 3 Pin	Hi-Z
33	AOUTL3N	O	Lch Negative Analog Output 3 Pin	Hi-Z
34	VREFH3	I	Positive Voltage Reference Input Pin, AVDD	Hi-Z
35	VREFL3	I	Negative Voltage Reference Input Pin, AVSS	Hi-Z
36	AOUTR3N	O	Rch Negative Analog Output 3 Pin	Hi-Z
37	AOUTR3P	O	Rch Positive Analog Output 3Pin	Hi-Z
38	AOUTL4P	O	Lch Positive Analog Output 4 Pin	Hi-Z
39	AOUTL4N	O	Lch Negative Analog Output 4 Pin	Hi-Z
40	VREFH4	I	Positive Voltage Reference Input Pin, AVDD	Hi-Z
41	VREFL4	I	Negative Voltage Reference Input Pin, AVSS	Hi-Z
42	AOUTR4N	O	Rch Negative Analog Output 4 Pin	Hi-Z
43	AOUTR4P	O	Rch Positive Analog Output 4 Pin	Hi-Z
44	LDOE	I	Internal LDO Enable Pin. "L": Disable, "H": Enable	Hi-Z
45	TVDD	-	Digital Power Supply Pin, 3.0V-3.6V	—
46	DVSS	-	Digital Ground Pin	—
47	VDD18	O	LDO Output Pin (LDOE pin = "H") This pin should be connected to DVSS with 1.0μF.	(Note 4)
		I	1.8V Power Input Pin (LDOE pin = "L")	
48	PDN	I	Power-Down & Reset Pin When this pin is "L", the AK4458 is powered-down and the control registers are reset to default state.	Hi-Z

Note 2. All input pins except internal pull-up/down pins should not be left floating.
Note 3. PCM mode and DSD mode are controlled by registers. Daisy Chain mode is controlled by both registers and pins.
Note 4. This pin outputs DVSS when the LDOE pin = "H" and Hi-z when the LDOE pin = "L".

FUNCTIONAL BLOCK DIAGRAM

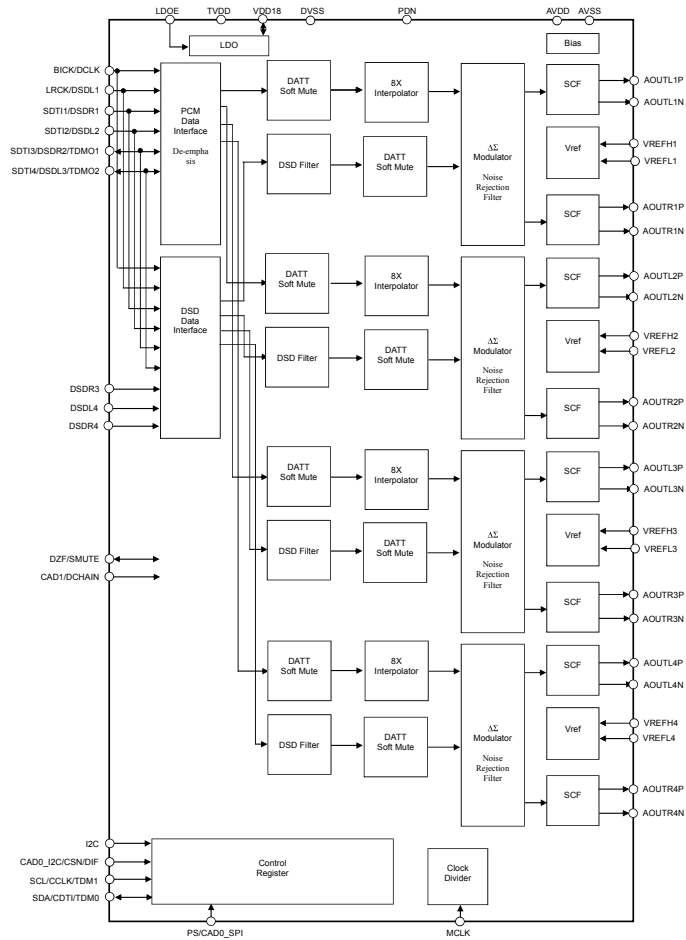

PCM5100 (DIGITAL : U1052)

PCM510x (top view)

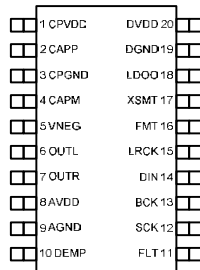

Table 2. TERMINAL FUNCTIONS, PCM510x

TERMINAL NAME	NO.	I/O	DESCRIPTION
CPVDD	1	-	Charge pump power supply, 3.3V
CAPP	2	O	Charge pump flying capacitor terminal for positive rail
CPGND	3	-	Charge pump ground
CAPM	4	O	Charge pump flying capacitor terminal for negative rail
VNEG	5	O	Negative charge pump rail terminal for decoupling, -3.3V
OUTL	6	O	Analog output from DAC left channel
OUTR	7	O	Analog output from DAC right channel
AVDD	8	-	Analog power supply, 3.3V
AGND	9	-	Analog ground
DEMP	10	I	De-emphasis control for 44.1kHz sampling rate ⁽¹⁾ : Off (Low) / On (High)
FLT	11	I	Filter select : Normal latency (Low) / Low latency (High)
SCK	12	I	System clock input
BCK	13	I	Audio data bit clock input
DIN	14	I	Audio data input
LRCK	15	I	Audio data word clock input
FMT	16	I	Audio format selection : I ² S (Low) / Left justified (High)
XSMT	17	I	Soft mute control : Soft mute (Low) / soft un-mute (High)
LDOO	18	-	Internal logic supply rail terminal for decoupling
DGND	19	-	Digital ground
DVDD	20	-	Digital power supply, 3.3V

Block Diagram

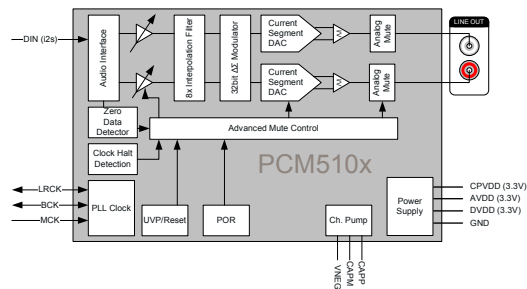
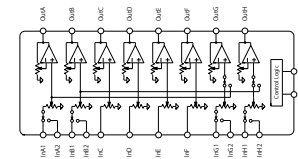

Figure 1. PCM510x Functional Block Diagram

NJU72343 (INPUT : U4202)



Pin Function

No.	Symbol	Function
1	AREF	Analog reference potential terminal
2	ADR	Address selection terminal
3	InA2	Ach input2
4	InB2	Bch input2
5	InA1	Ach input1
6	InB1	Bch input1
7	InC	Cch input
8	InD	Dch input
9	InE	Ech input
10	InF	Fch input
11	InG1	Gch input1
12	InH1	Hch input1
13	InG2	Cch input2
14	InH2	Dch input2
15	MUTE	External mute control terminal
16	REF	Digital reference potential terminal
17	DATA	IC control data input
18	CLOCK	IC control clock input
19	VDDOUT	Digital power supply output terminal
20	AREF	Analog reference potential terminal
21	OutH	Hch output
22	OutG	Gch output
23	OutF	Fch output
24	OutE	Ech output
25	OutD	Dch output
26	OutC	Cch output
27	OutB	Bch output
28	OutA	Ach output
29	AREF	Analog reference potential terminal
30	V-	negative power supply terminal
31	AREF	Analog reference potential terminal
32	V+	positive power supply terminal

NJU72750A (INPUT : U4201,U4203)

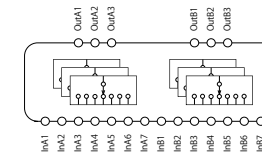

Pin Function

No.	Symbol	Function
1	V+	positive power supply terminal
2	InA1	Ach input1
3	InB1	Bch input1
4	InA2	Ach input2
5	InB2	Bch input2
6	InA3	Ach input3
7	InB3	Bch input3
8	InA4	Ach input4
9	InB4	Bch input4
10	InA5	Ach input5
11	InB5	Bch input5
12	InA6	Ach input6
13	InB6	Bch input6
14	InA7	Ach input7
15	InB7	Bch input7
16	REF	Reference potential terminal for BIAS
17	DATA	IC control data input
18	CLOCK	IC control clock input
19	NC	-
20	NC	-
21	OutB3	Bch output3
22	OutA3	Ach output3
23	REF_B	Bch reference potential terminal
24	OutB2	Bch output2
25	OutA2	Ach output2
26	REF_A	Ach reference potential terminal
27	OutB1	Bch output1
28	OutA1	Ach output1
29	NC	-
30	ADR0	Address selection pin 0
31	ADR1	Address selection pin 1
32	V-	negative power supply terminal

NJM2595MTE1 (VIDEO : IC5001)

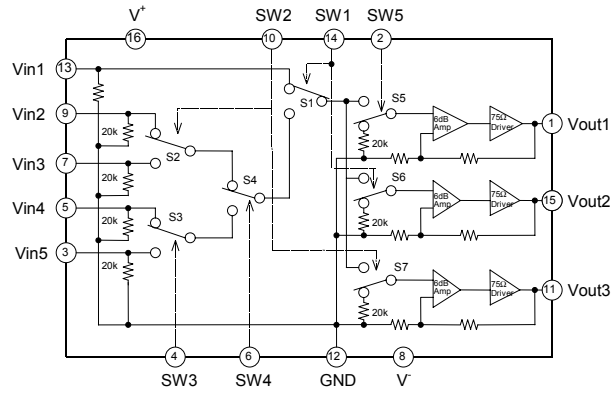

NJM2586AVC3(VIDEO : IC5002)

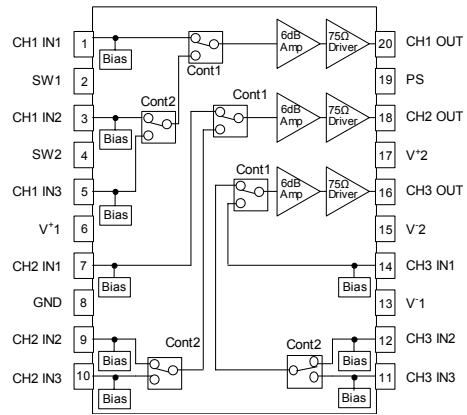

SSOP20-C3

2. FL DISPLAY

FLD (018BT021GINK) (FRONT : FL4400)

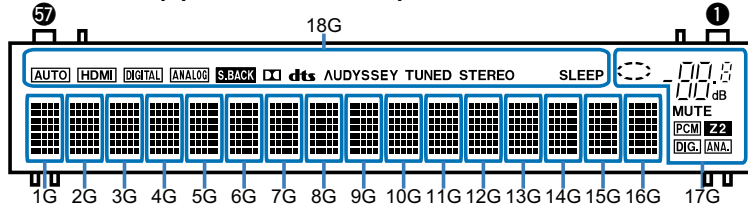

PIN CONNECTION

CONNECTION	PIN NO.
F2	57
NP	56
NP	55
NP	54
NP	53
LGND	52
PGND	51

CONNECTION	PIN NO.
VDD	50
OSC	49
RESET	48
CS	47
CP	46
DA	45
TSA	44
TSB	43
NX	42
NX	41
NX	40
NX	39
NX	38
NX	37
NX	36
NX	35
NX	34
NX	33
NX	32
NX	31
NX	30
NX	29
NX	28
NX	27
NX	26
NX	25
NX	24
NX	23
NX	22
NX	21
NX	20
NX	19
NX	18
NX	17
NX	16
NX	15
NX	14
NX	13
NX	12
NX	11
NX	10
NX	9
18G	8
17G	7
Q17G	6
Q18G	5
NP	4
NP	3
NP	2
F1	1

NOTE

- 1) F1, F2 ----Filament
- 2) NP -----No pin
- 3) DL -----Datum Line
- 4) NX -----No extend pin
- 5) LGND ----Logic GND pin
- 6) PGND ----Power GND pin
- 7) VH -----High Voltage Supply pin
- 8) VDD -----Logic Voltage Supply pin
- 9) CP ----Shift Register Clock
- 10) DA ----Serial Data Input
- 11) TSA, B --Test pin
- 12) CS -----Chip Select Input pin
- 13) RESET --Reset Input
- 14) OSC ----Pin for self-oscillation
- 15) Solder composition is Sn-3Ag-0.5Cu.
- 16) 17G, 18G ---Grid
- 17) Q17G, Q18G ---Driver Output Port.
- 18) Field of vision is a minimum of 21.8° from the lower side.

ANODE CONNECTION

	1G	2G	3G	4G	5G	6G	7G	8G	9G	10G	11G	12G	13G	14G	15G	16G	17G(AD3)	18G(AD4)
D0	1-1	1-1	1-1	1-1	1-1	1-1	1-1	1-1	1-1	1-1	1-1	1-1	1-1	1-1	1-1	1-1	S9	-
D1	2-1	2-1	2-1	2-1	2-1	2-1	2-1	2-1	2-1	2-1	2-1	2-1	2-1	2-1	2-1	2-1	3d	-
D2	3-1	3-1	3-1	3-1	3-1	3-1	3-1	3-1	3-1	3-1	3-1	3-1	3-1	3-1	3-1	3-1	2d	-
D3	4-1	4-1	4-1	4-1	4-1	4-1	4-1	4-1	4-1	4-1	4-1	4-1	4-1	4-1	4-1	4-1	3e	-
D4	5-1	5-1	5-1	5-1	5-1	5-1	5-1	5-1	5-1	5-1	5-1	5-1	5-1	5-1	5-1	5-1	2e	-
D5	1-2	1-2	1-2	1-2	1-2	1-2	1-2	1-2	1-2	1-2	1-2	1-2	1-2	1-2	1-2	1-2	3c	-
D6	2-2	2-2	2-2	2-2	2-2	2-2	2-2	2-2	2-2	2-2	2-2	2-2	2-2	2-2	2-2	2-2	2c	-
D7	3-2	3-2	3-2	3-2	3-2	3-2	3-2	3-2	3-2	3-2	3-2	3-2	3-2	3-2	3-2	3-2	3g	-
D8	4-2	4-2	4-2	4-2	4-2	4-2	4-2	4-2	4-2	4-2	4-2	4-2	4-2	4-2	4-2	4-2	2g	-
D9	5-2	5-2	5-2	5-2	5-2	5-2	5-2	5-2	5-2	5-2	5-2	5-2	5-2	5-2	5-2	5-2	3f	-
D10	1-3	1-3	1-3	1-3	1-3	1-3	1-3	1-3	1-3	1-3	1-3	1-3	1-3	1-3	1-3	1-3	2f	-
D11	2-3	2-3	2-3	2-3	2-3	2-3	2-3	2-3	2-3	2-3	2-3	2-3	2-3	2-3	2-3	2-3	3b	-
D12	3-3	3-3	3-3	3-3	3-3	3-3	3-3	3-3	3-3	3-3	3-3	3-3	3-3	3-3	3-3	3-3	2b	-
D13	4-3	4-3	4-3	4-3	4-3	4-3	4-3	4-3	4-3	4-3	4-3	4-3	4-3	4-3	4-3	4-3	3a	-
D14	5-3	5-3	5-3	5-3	5-3	5-3	5-3	5-3	5-3	5-3	5-3	5-3	5-3	5-3	5-3	5-3	2a	-
D15	1-4	1-4	1-4	1-4	1-4	1-4	1-4	1-4	1-4	1-4	1-4	1-4	1-4	1-4	1-4	1-4	Dp	-
D16	2-4	2-4	2-4	2-4	2-4	2-4	2-4	2-4	2-4	2-4	2-4	2-4	2-4	2-4	2-4	2-4	dB	-
D17	3-4	3-4	3-4	3-4	3-4	3-4	3-4	3-4	3-4	3-4	3-4	3-4	3-4	3-4	3-4	3-4	1d	-
D18	4-4	4-4	4-4	4-4	4-4	4-4	4-4	4-4	4-4	4-4	4-4	4-4	4-4	4-4	4-4	4-4	1e	-
D19	5-4	5-4	5-4	5-4	5-4	5-4	5-4	5-4	5-4	5-4	5-4	5-4	5-4	5-4	5-4	5-4	1c	-
D20	1-5	1-5	1-5	1-5	1-5	1-5	1-5	1-5	1-5	1-5	1-5	1-5	1-5	1-5	1-5	1-5	1g	-
D21	2-5	2-5	2-5	2-5	2-5	2-5	2-5	2-5	2-5	2-5	2-5	2-5	2-5	2-5	2-5	2-5	1f	-
D22	3-5	3-5	3-5	3-5	3-5	3-5	3-5	3-5	3-5	3-5	3-5	3-5	3-5	3-5	3-5	3-5	1b	-
D23	4-5	4-5	4-5	4-5	4-5	4-5	4-5	4-5	4-5	4-5	4-5	4-5	4-5	4-5	4-5	4-5	1a	AUTO
D24	5-5	5-5	5-5	5-5	5-5	5-5	5-5	5-5	5-5	5-5	5-5	5-5	5-5	5-5	5-5	5-5	S1	HDMI
D25	1-6	1-6	1-6	1-6	1-6	1-6	1-6	1-6	1-6	1-6	1-6	1-6	1-6	1-6	1-6	1-6	S2	DIGITAL
D26	2-6	2-6	2-6	2-6	2-6	2-6	2-6	2-6	2-6	2-6	2-6	2-6	2-6	2-6	2-6	2-6	S3	ANALOG
D27	3-6	3-6	3-6	3-6	3-6	3-6	3-6	3-6	3-6	3-6	3-6	3-6	3-6	3-6	3-6	3-6	S4	S.BACK
D28	4-6	4-6	4-6	4-6	4-6	4-6	4-6	4-6	4-6	4-6	4-6	4-6	4-6	4-6	4-6	4-6	S5	DL
D29	5-6	5-6	5-6	5-6	5-6	5-6	5-6	5-6	5-6	5-6	5-6	5-6	5-6	5-6	5-6	5-6	S6	dts
D30	1-7	1-7	1-7	1-7	1-7	1-7	1-7	1-7	1-7	1-7	1-7	1-7	1-7	1-7	1-7	1-7	S7	AUDYSSEY
D31	2-7	2-7	2-7	2-7	2-7	2-7	2-7	2-7	2-7	2-7	2-7	2-7	2-7	2-7	2-7	2-7	S8	TUNED
D32	3-7	3-7	3-7	3-7	3-7	3-7	3-7	3-7	3-7	3-7	3-7	3-7	3-7	3-7	3-7	3-7	MUTE	STEREO
D33	4-7	4-7	4-7	4-7	4-7	4-7	4-7	4-7	4-7	4-7	4-7	4-7	4-7	4-7	4-7	4-7	PCM	RDS
D34	5-7	5-7	5-7	5-7	5-7	5-7	5-7	5-7	5-7	5-7	5-7	5-7	5-7	5-7	5-7	5-7	Z2	SLEEP
AD1	-	-	-	-	-	-	-	-	-	-	-	-	-	-	-	-	DIG.	-
AD2	-	-	-	-	-	-	-	-	-	-	-	-	-	-	-	-	ANA.	-

DISASSEMBLY

Flowchart

1. WiFi ANT
2. FRONT PANEL ASSY
3. RADIATOR ASSY
4. DIGITAL PCB
5. VIDEO PCB
6. MAIN PCB
7. SMPS PCB
8. TRANS

EXPLODED VIEW

PACKING VIEW

Flowchart

- Remove each part following the flow below.
- Reassemble the removed parts in the reverse order.
- Read "[SAFETY PRECAUTIONS](#)" before reassembling the removed parts.
- If wire bundles are removed or moved during adjustment or part replacement, reshape the wires after completing the work. Failure to shape the wires correctly may cause problems such as noise.
- See "[EXPLODED VIEW](#)"

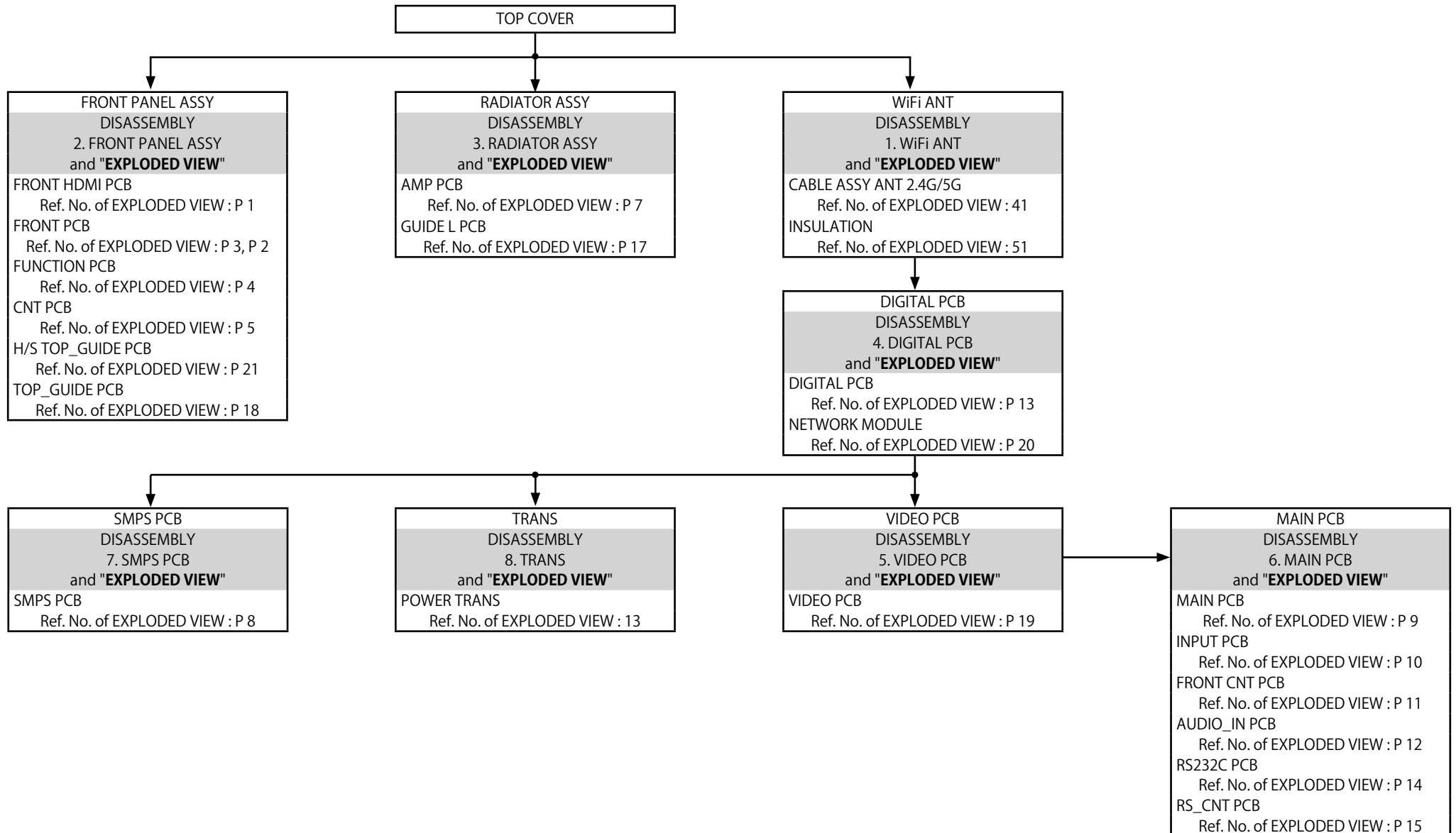

Caution in servicing

Electrical

Mechanical

Repair Information

Updating

Explanatory Photos for DISASSEMBLY

- For the shooting direction of each photos used in this manual, see the photo below.
- **A, B, C and D** in the photo below indicate the shooting directions of photos.
- The photographs with no shooting direction indicated were taken from the top of the unit.
- Photos of AVR-X2400H E3 are used in this manual.

The viewpoint of each photograph

(Shooting direction : X) [View from the top]

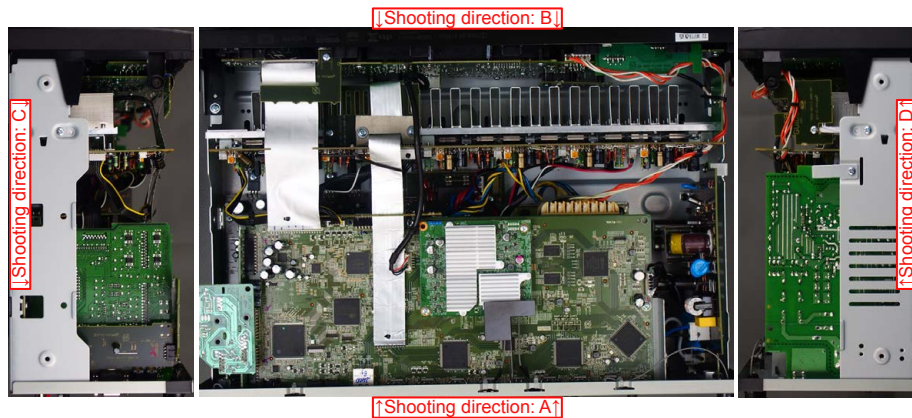

1. WiFi ANT

Proceeding : **TOP COVER** → **WiFi ANT**

- (1) Remove the INSULATION SHEET. Cut the wire clamps.

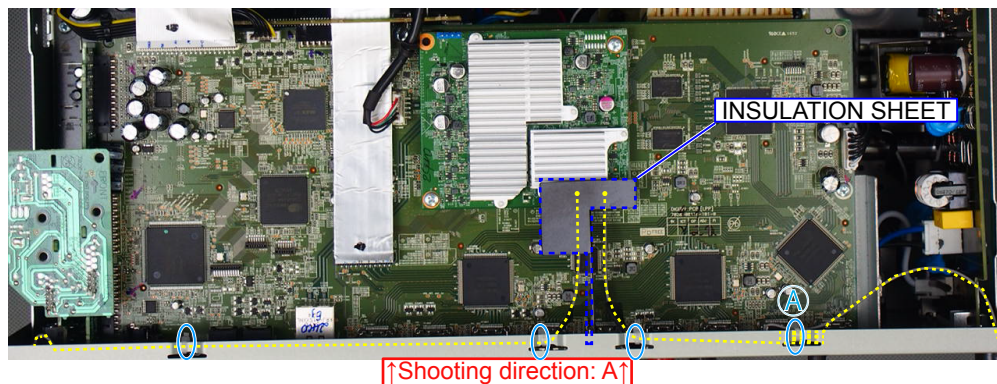

NOTE :

- If the INSULATION SHEET has been removed, replace with a new sheet.
- When attaching the INSULATION SHEET, align with the Silk-Print and up to side of the NETWORK MODULE PCB.
- Turn up and spare wire at position A.

2. FRONT PANEL ASSY

Proceeding : **TOP COVER** → **FRONT PANEL ASSY**

- (1) Remove the screws.

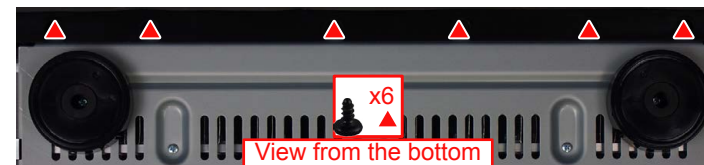

- (2) Remove the screws. Remove the CORD HOLDER and connectors. Remove the FFC.

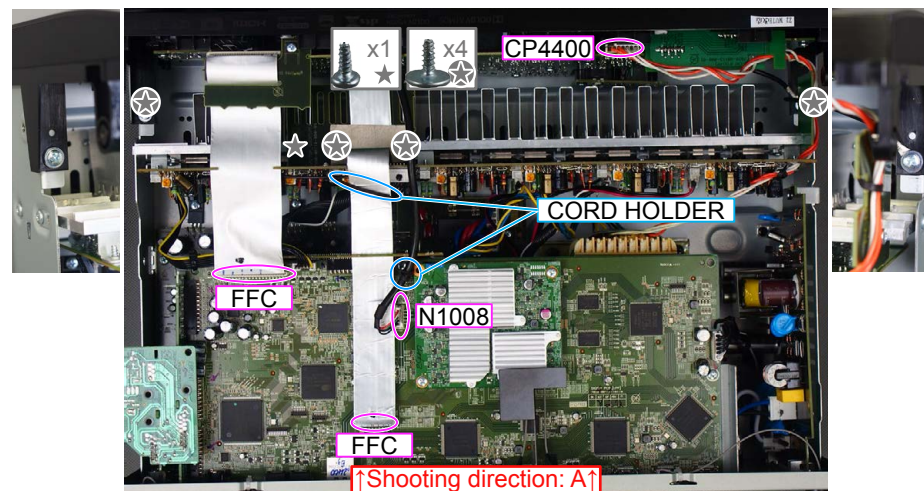

3. RADIATOR ASSY

Proceeding : **TOP COVER** → **RADIATOR ASSY**

(1) Remove the screws.



(2) Remove the screws. Remove the CORD HOLDER and connectors. Remove the FFC.

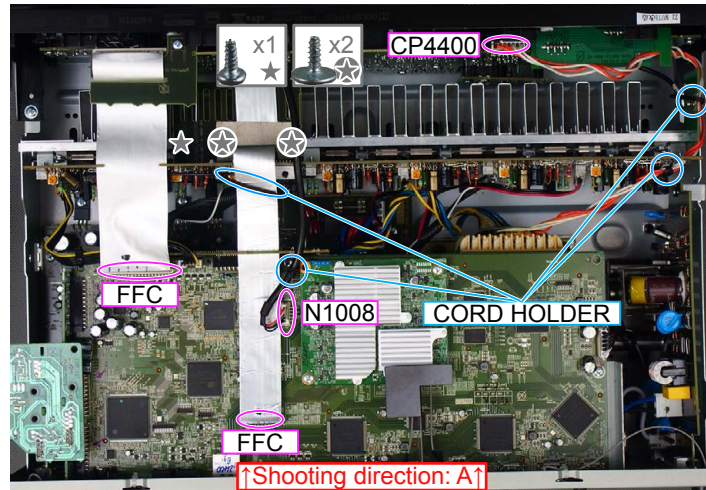

(3) Remove the connector.

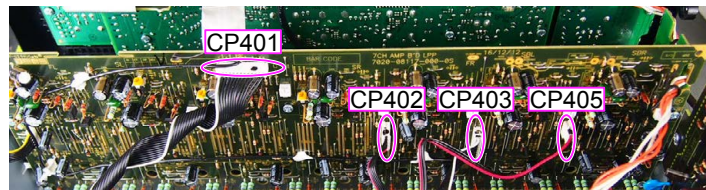

4. DIGITAL PCB

Proceeding : **TOP COVER** → **WiFi ANT** → **DIGITAL PCB**

(1) Remove the screws.



(2) Cut the wire clamps, then remove the CORD HOLDERS and connectors. Remove the FFC.

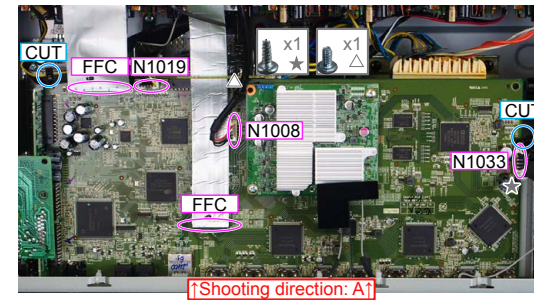

(3) Remove the connector.

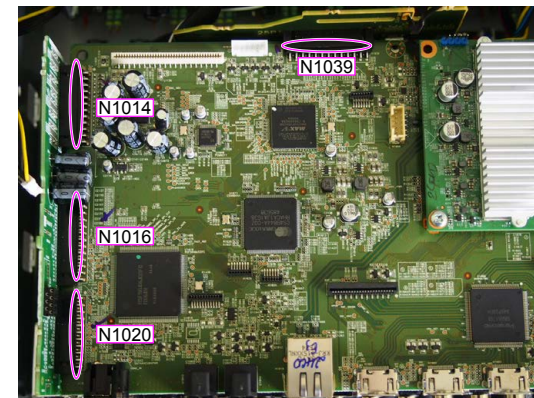

5. VIDEO PCB

Proceeding : **TOP COVER** → **WiFi ANT** → **DIGITAL PCB** → **VIDEO PCB**

(1) Remove the connector.

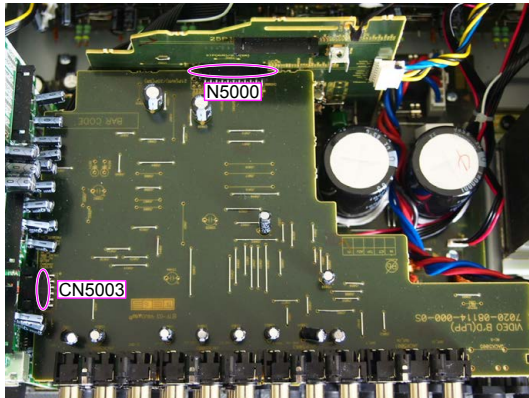

6. MAIN PCB

Proceeding : **TOP COVER** → **WiFi ANT** → **DIGITAL PCB** → **VIDEO PCB** → **MAIN PCB**

(1) Remove the screws.

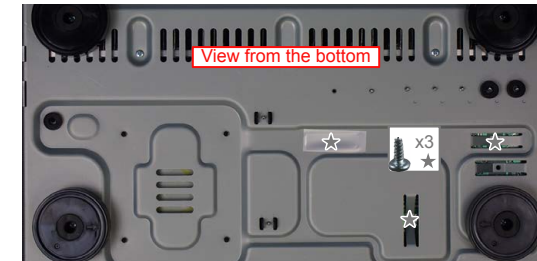

(2) Remove the screws. Remove the connector.

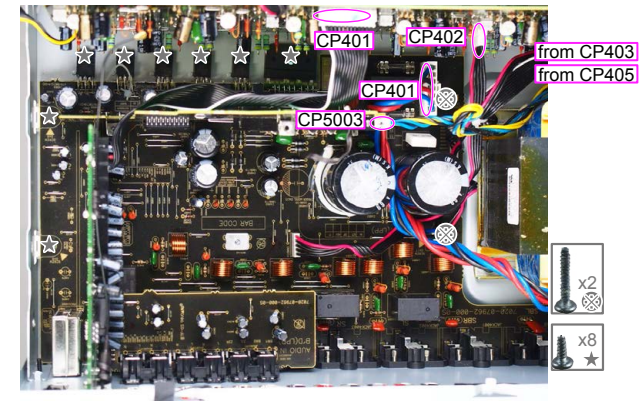

7. SMPS PCB

Proceeding : **TOP COVER** → **SMPS PCB**

See "[EXPLODED VIEW](#)" for instructions on removing the SMPS PCB.

8. TRANS

Proceeding : **TOP COVER** → **COVER** → **DIGITAL PCB** → **TRANS**

See "[EXPLODED VIEW](#)" for instructions on removing the transformer (TRANS).

EXPLODED VIEW

Parts List : <http://dmedia.dmglobal.com/Document/DocumentDetails/23152>

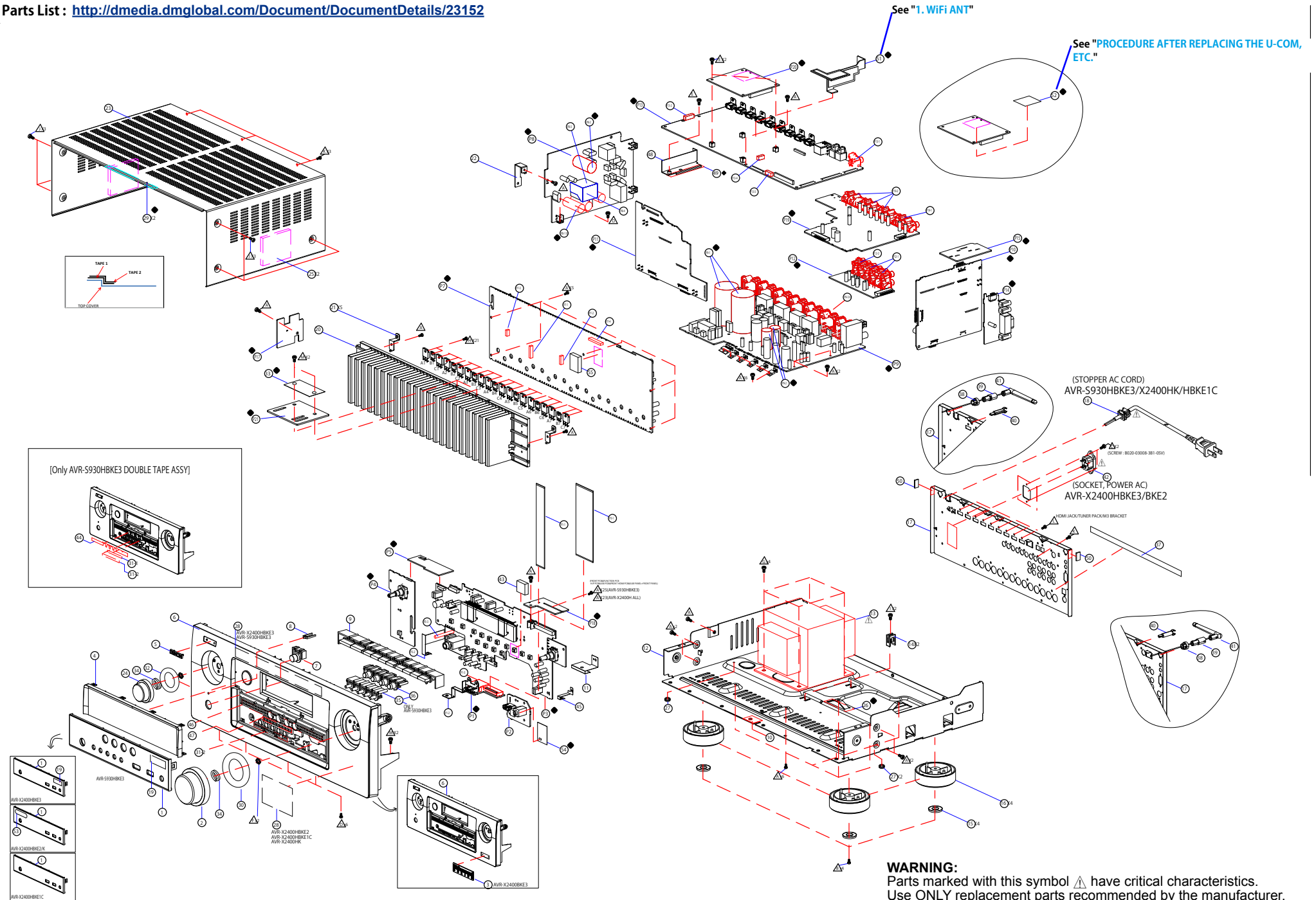

Caution in servicing

Electrical

Mechanical

Repair Information

Updating

PACKING VIEW

Parts List : <http://dmedia.dmglobal.com/Document/DocumentDetails/23152>

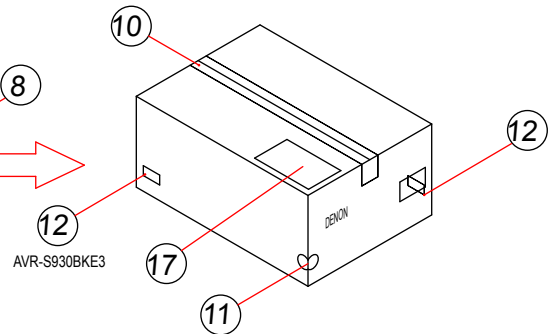
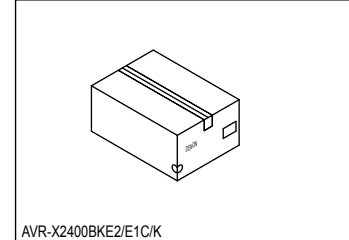
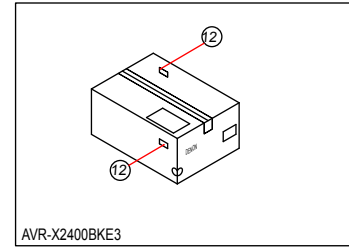
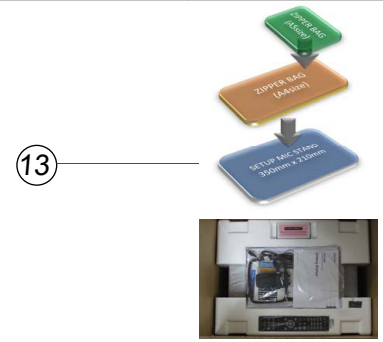
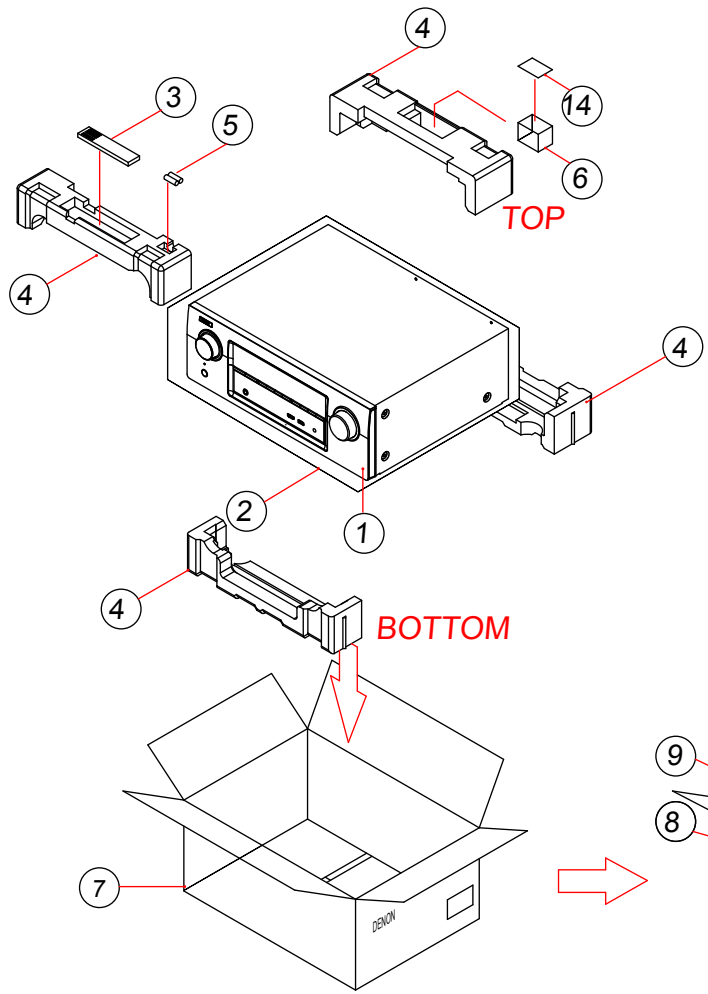
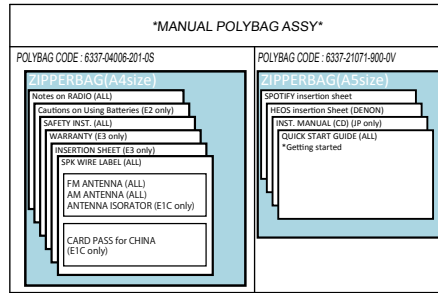

* POLY BAG PACKING STYLE	SPEAKER TERMINAL BUSHING	* BOX BOTTOM TAPING
<p>15</p> <p>16</p> <p>OLNY UK(向) PLUG(at store)</p>	<p>16</p>	<p>10</p>

Caution in servicing

Electrical

Mechanical

Repair Information

Updating

REPAIR INFORMATION

TROUBLE SHOOTING

1. POWER
2. Analog video
3. HDMI/DVI
4. AUDIO
5. Network / Bluetooth / USB
6. SMPS

HDMI "Rx/Tx" Failure Detection

1. Prior checking
2. Preparations for checking HDMI Switcher reception/transmission register
3. Starting detecting the point of failure
4. Device implementation location

CLOCK FLOW & WAVE FORM IN DIGITAL BLOCK

SPECIAL MODE

Special mode setting button **AVR-X2400H**

Special mode setting button **AVR-S930H**

1. Version Display Mode
2. PANEL / REMOTE LOCK Selection Mode
 - 3-1. Selecting the Mode for Service-related
 - 3-2. Protection History Display Mode
 - 3-3. 232C Standby Clear Mode (AVR-X2400H E3 only)
 - 3-4. Operation Info Mode
 - 3-5. TUNER STEP mode (E2 / E3 only)
 - 3-6. Remote ID Setup Mode
4. Protection Pass Mode
5. Network Initialization Mode
7. Clearing the Operation Info

DIAGNOSTIC MODE

Service Path Check Mode

DIAGNOSTIC PATH DIAGRAM

JIG FOR SERVICING

ADJUSTMENT

TROUBLE SHOOTING

1. POWER

1.1. The unit does not power on

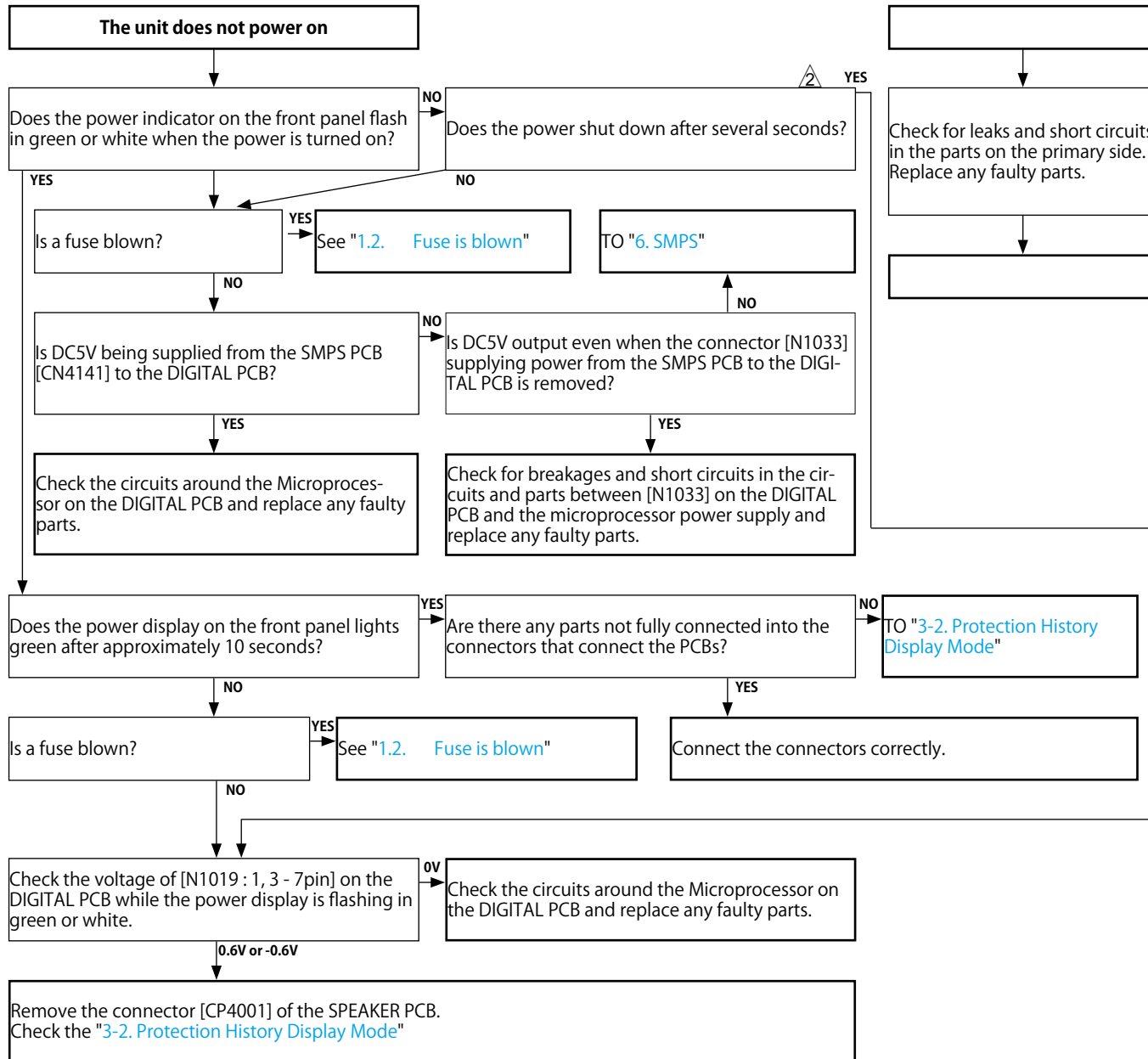

1.2. Fuse is blown

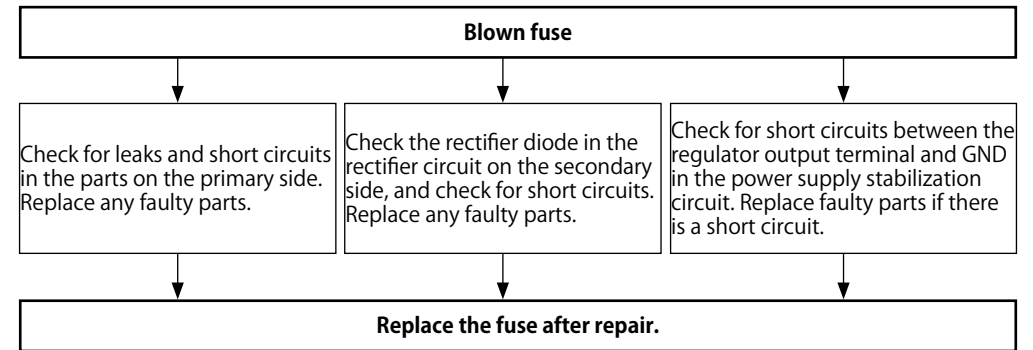

Caution in servicing

Electrical

Mechanical

Repair Information

Updating

2. Analog video

DIGITAL test point

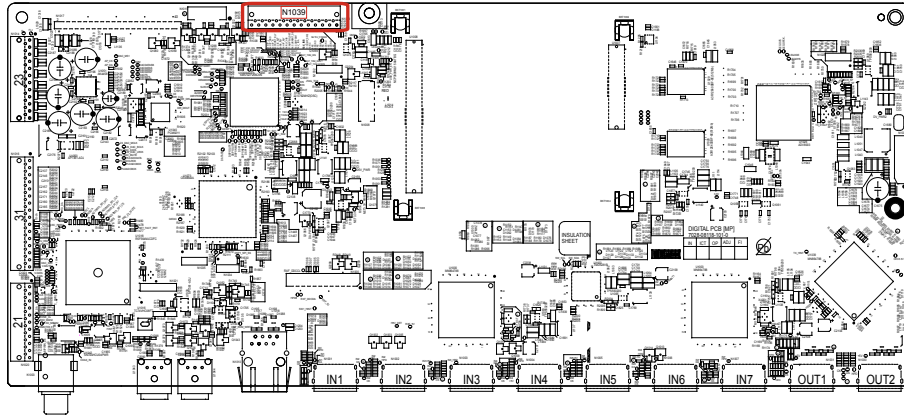

VIDEO test point

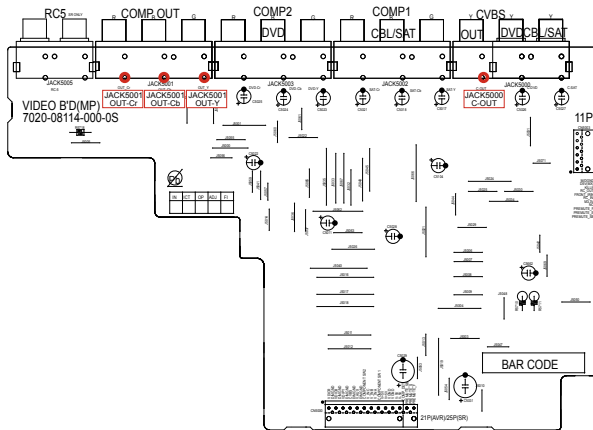

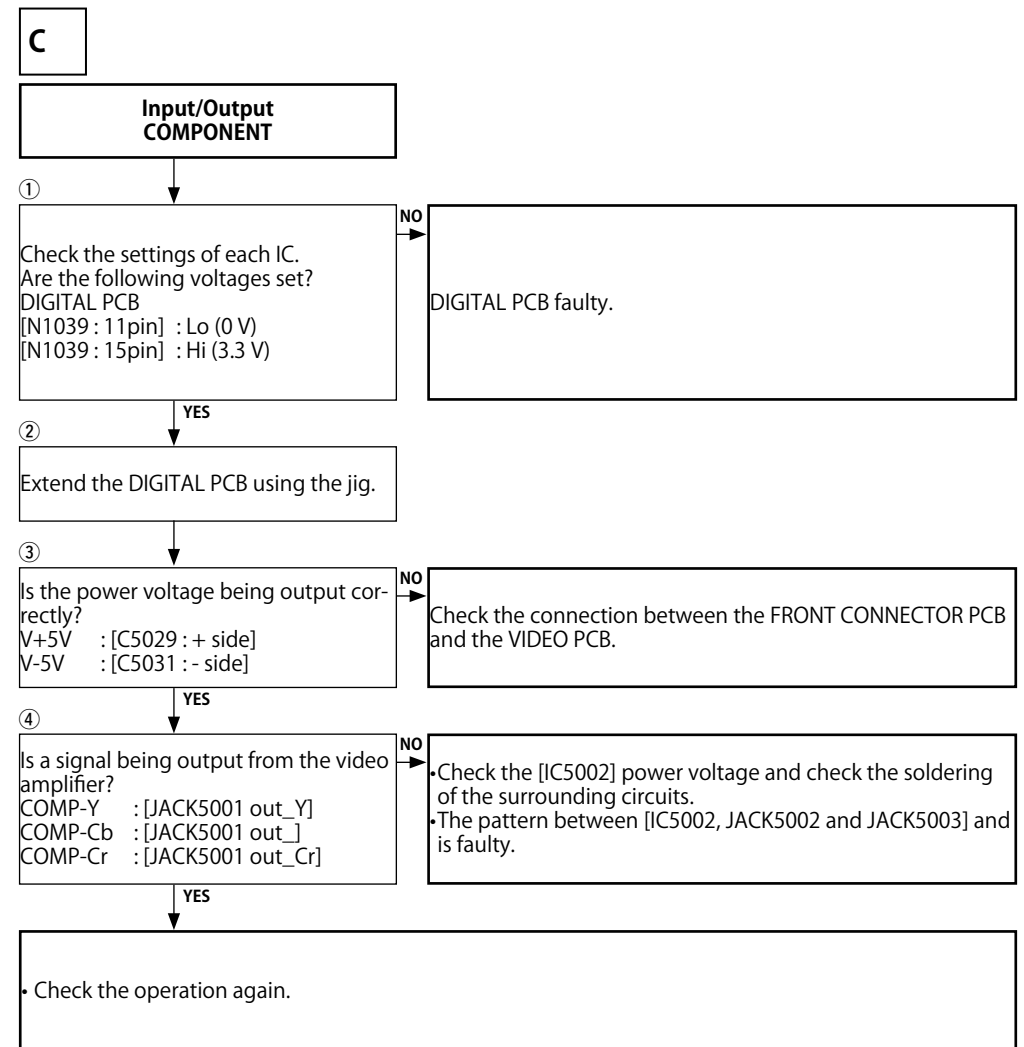
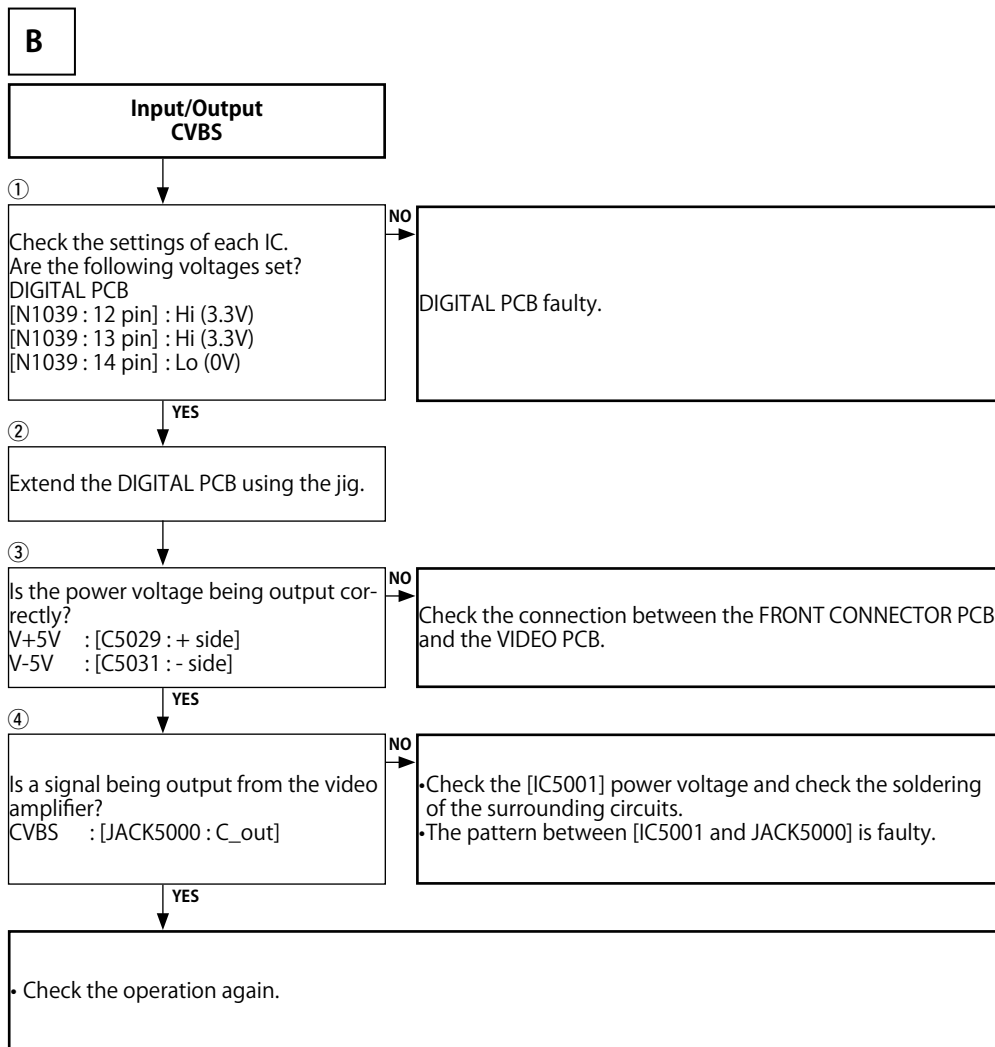

※ These instructions refer to the VIDEO PCB unless otherwise specified.

※ These instructions refer to the VIDEO PCB unless otherwise specified.

3. HDMI/DVI

3.1. No picture or sound is output (HDMI to HDMI)

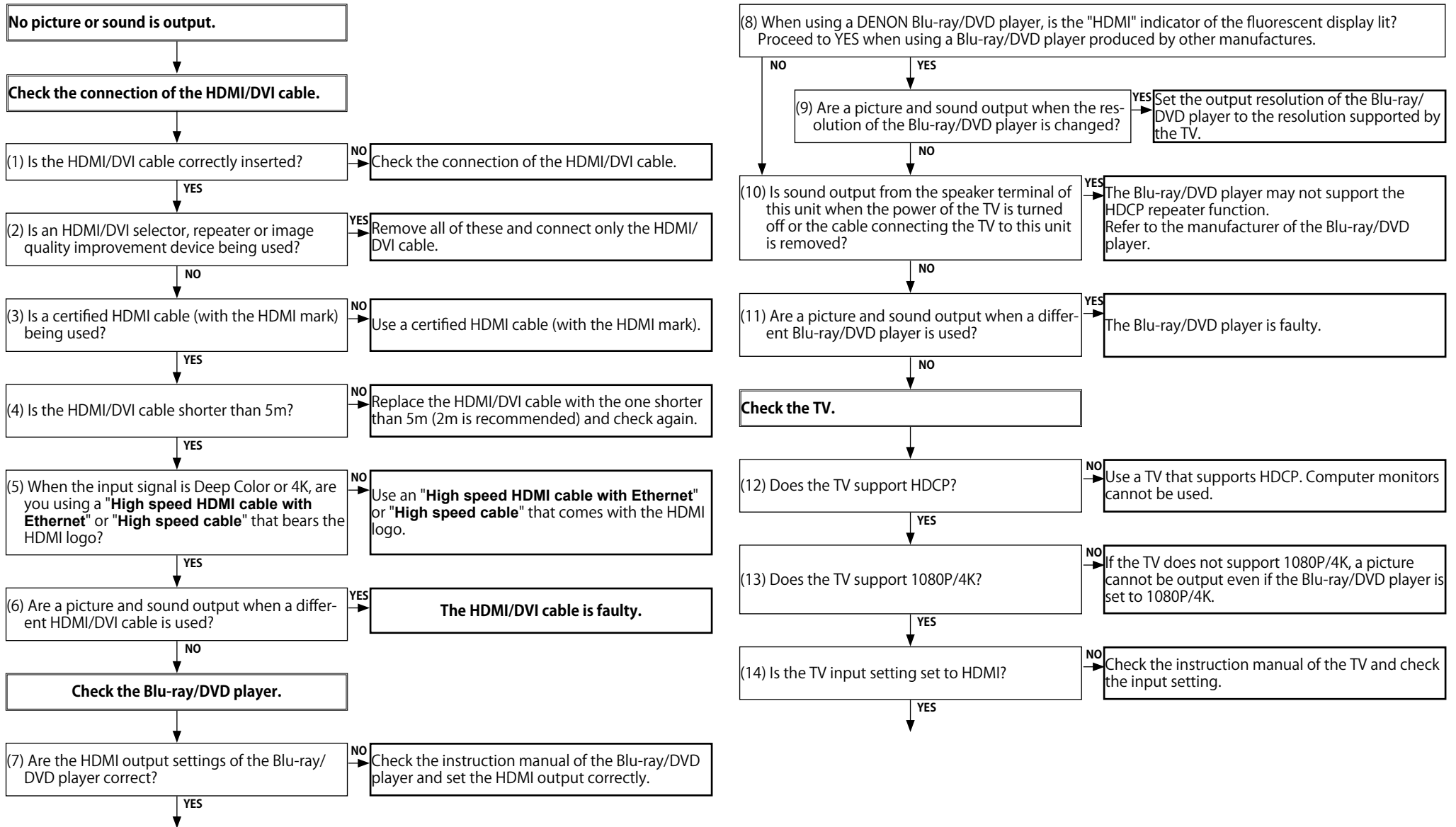

Go to next page.

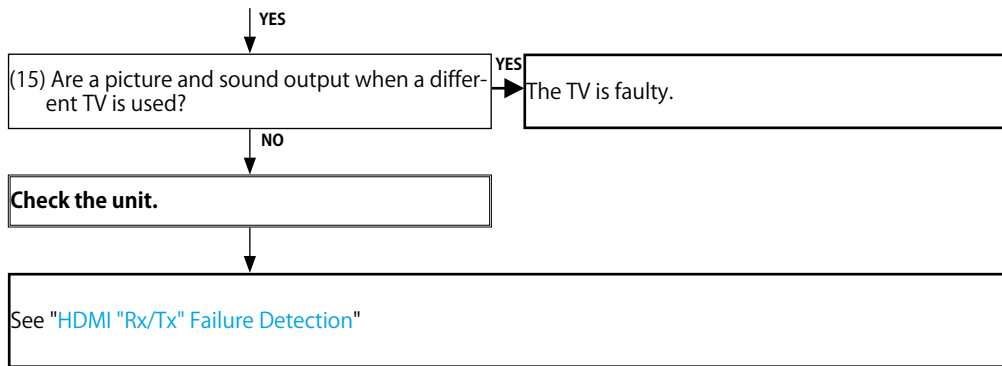

4. AUDIO

4.1. AUDIO CHECK

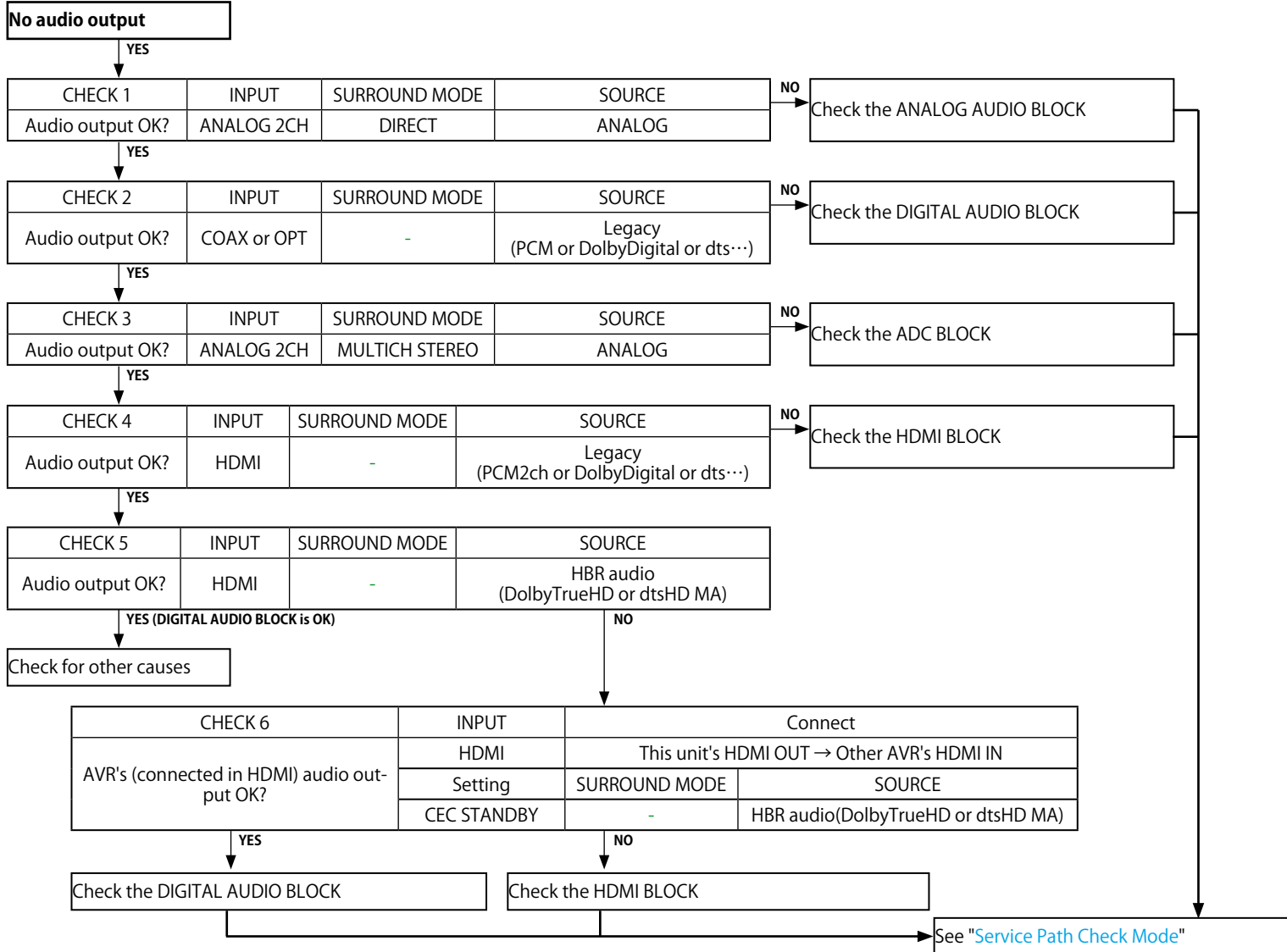

4.2. Power AMP (AMP PCB)

When using the protection pass mode, do not connect speakers to the speaker terminals.

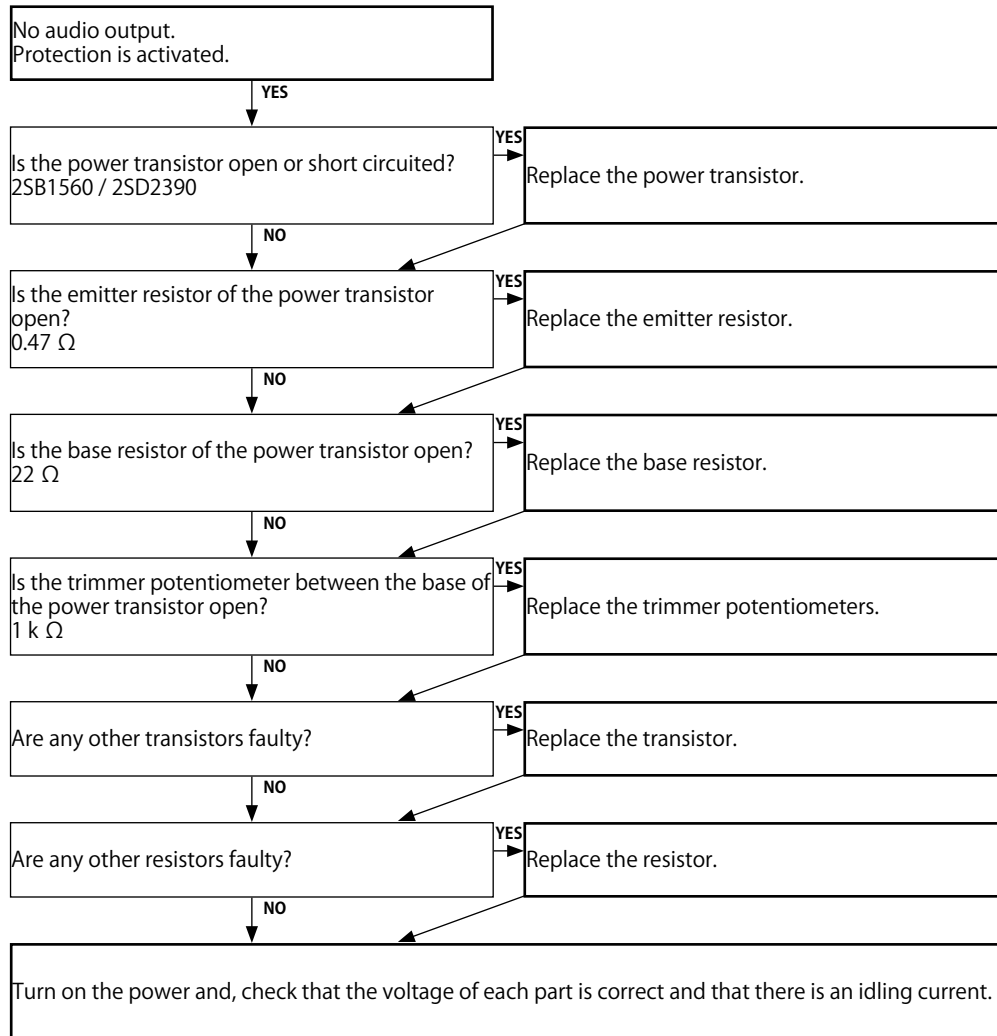

4.3. Analog audio

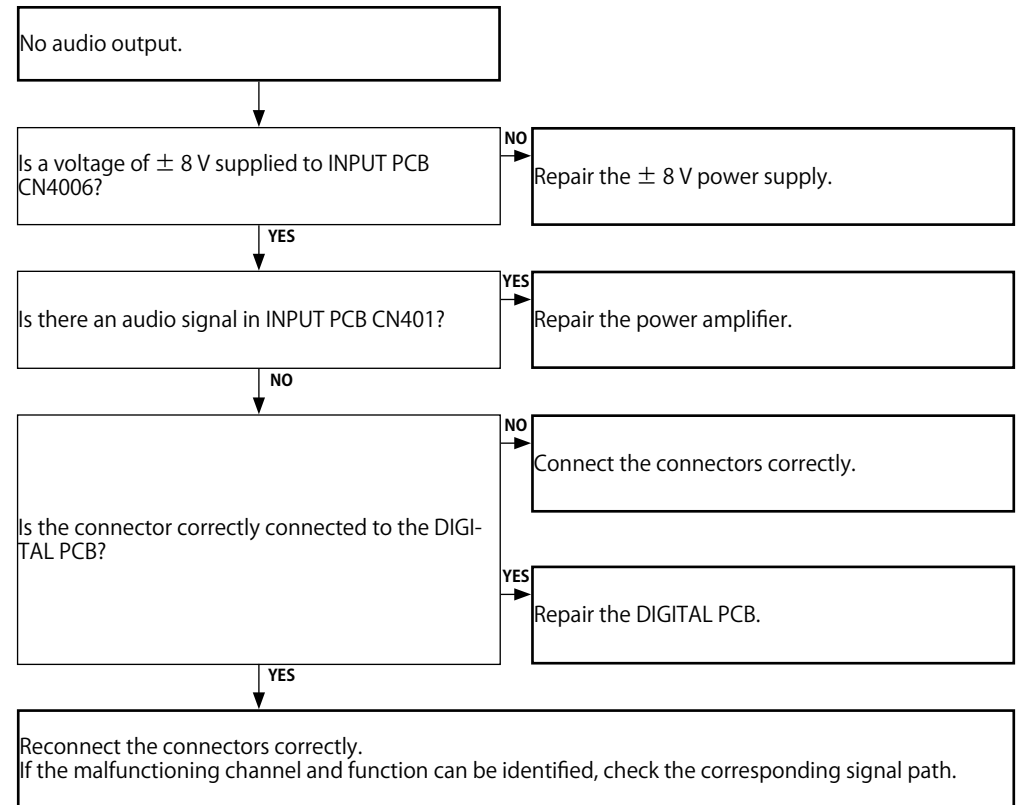

5. Network / Bluetooth / USB

5.1. Cannot connect to the network

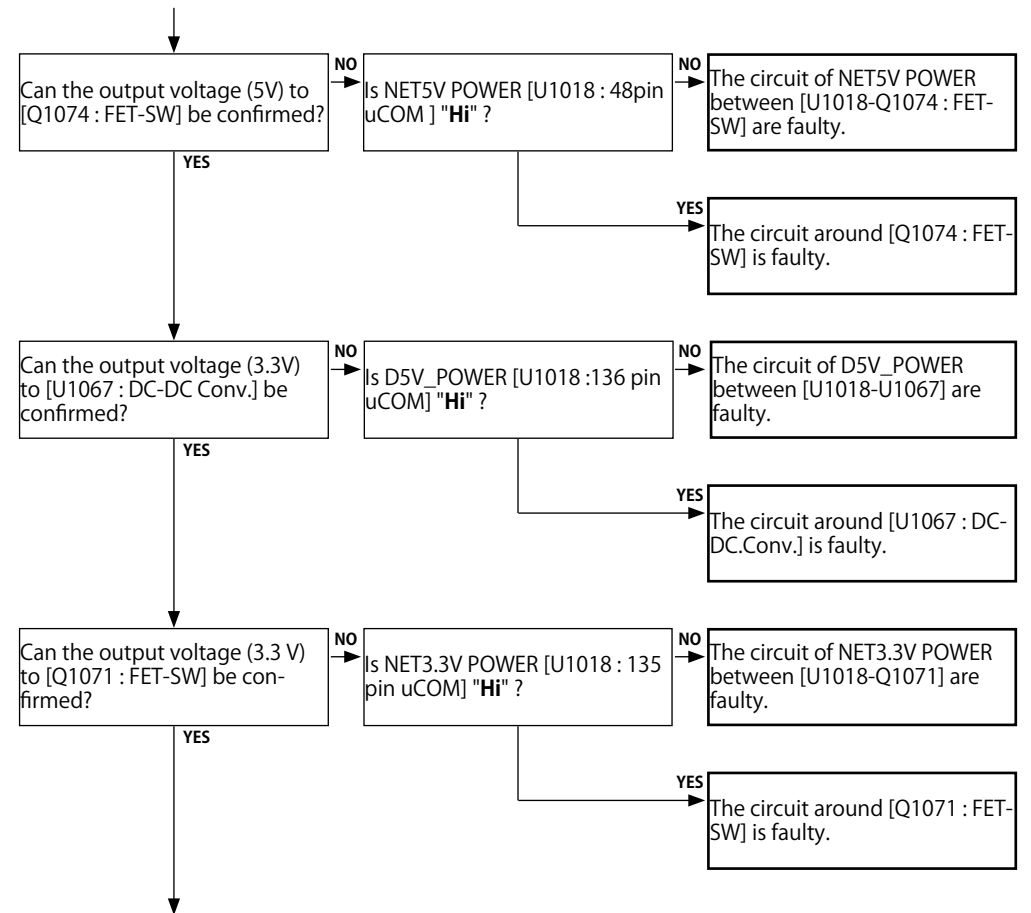
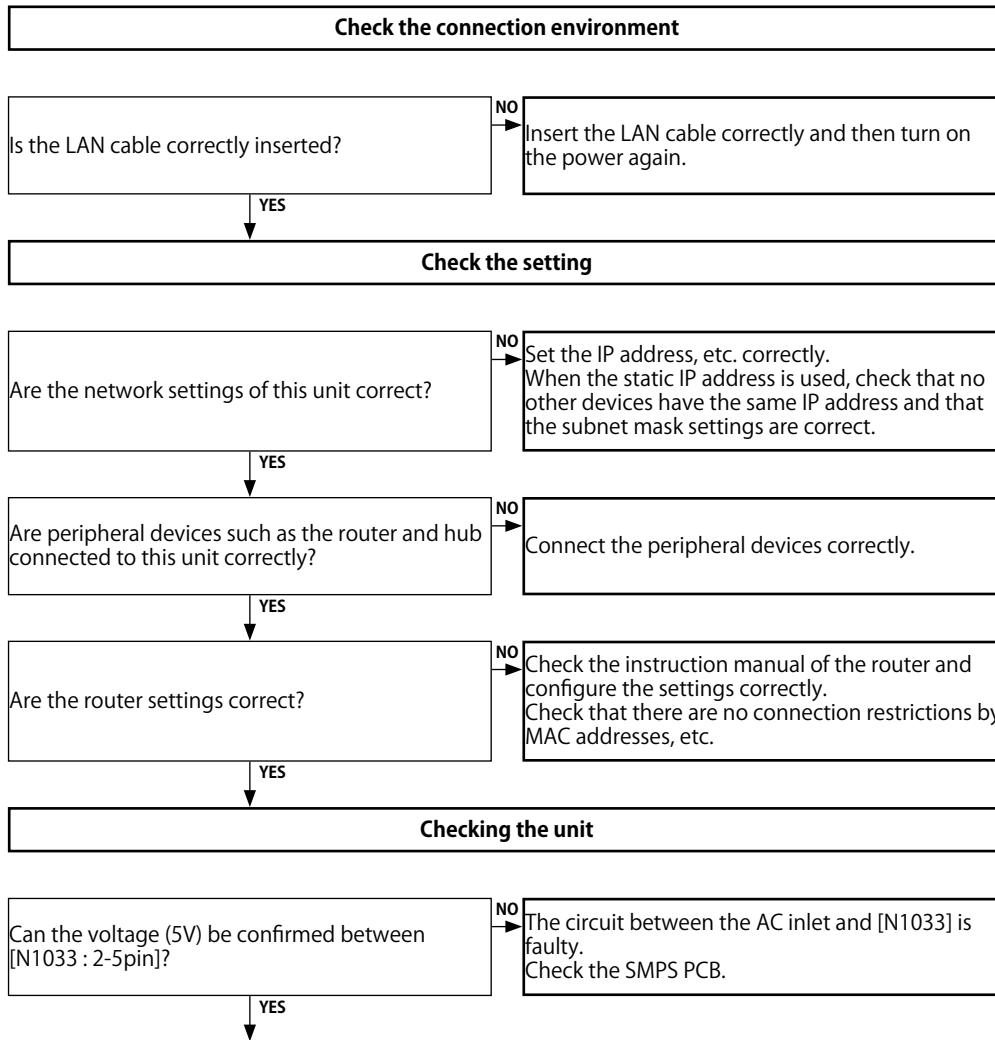

Go to next page.

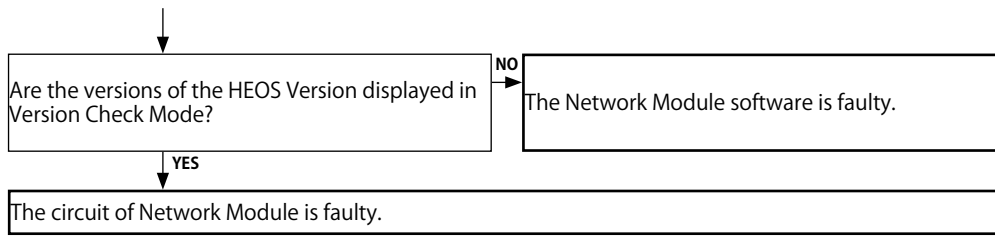

5.2. Cannot establish a Bluetooth connection

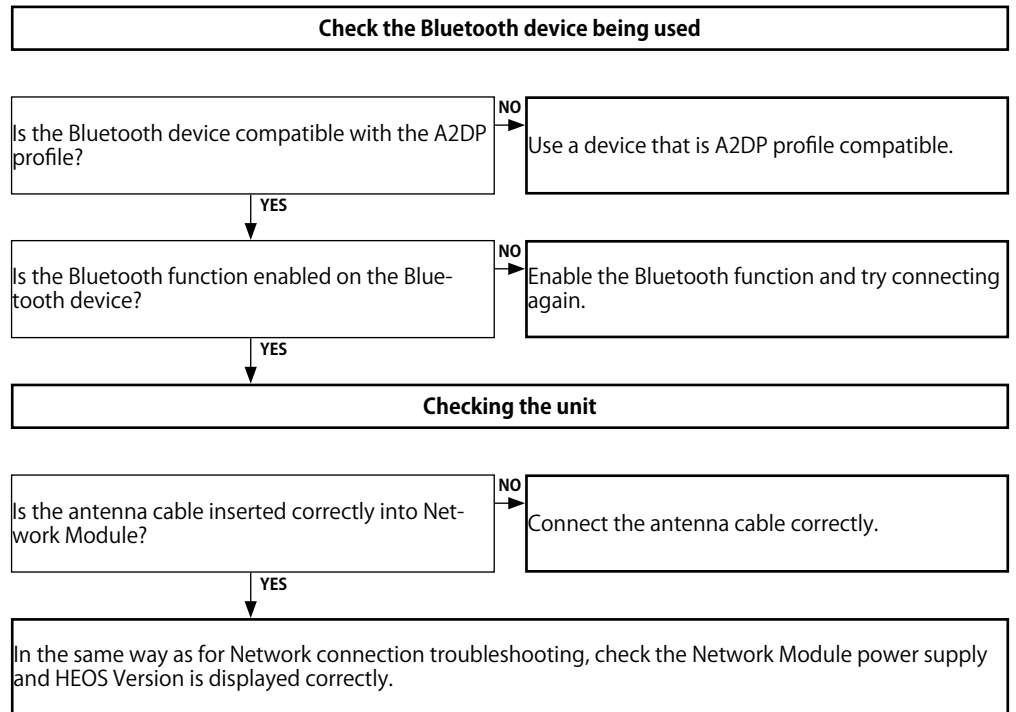

5.3. Cannot recognize the connected USB device

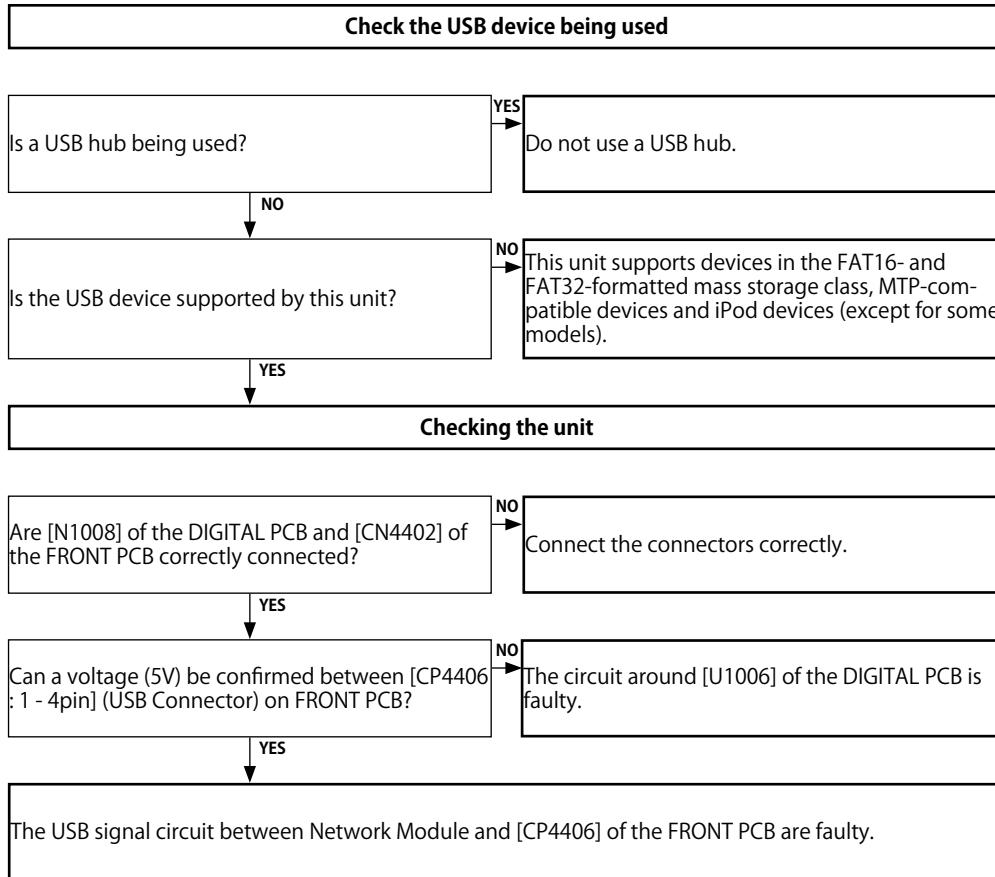

5.4. No picture or sound is output

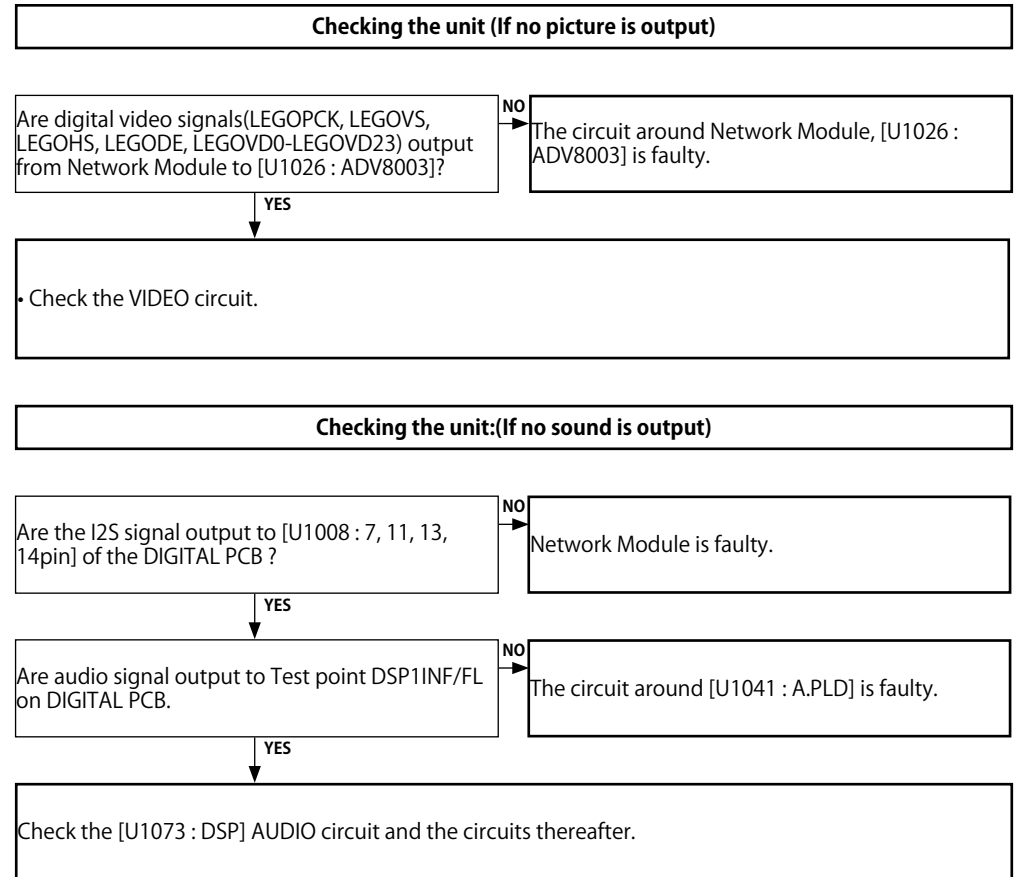

DIGITAL test point

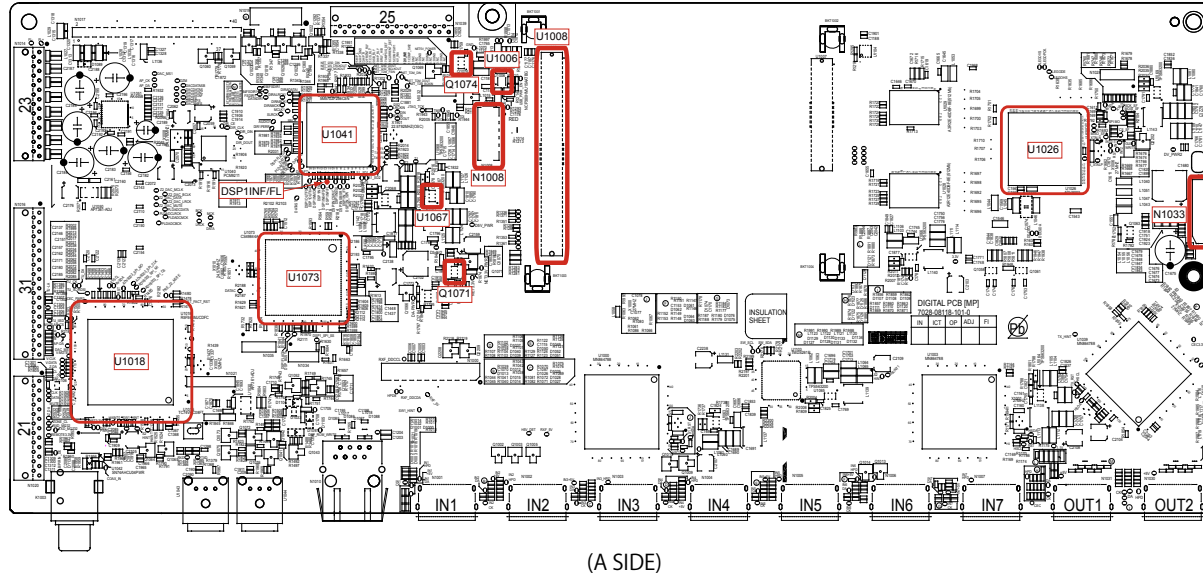

USB test point

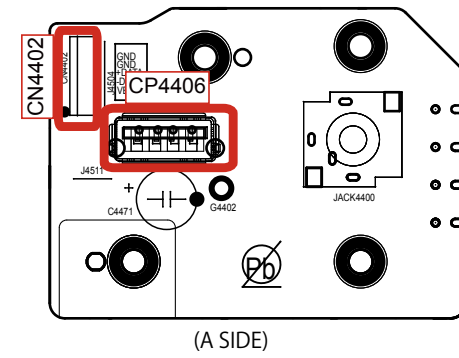

Caution in servicing

Electrical

Mechanical

Repair Information

Updating

6. SMPS

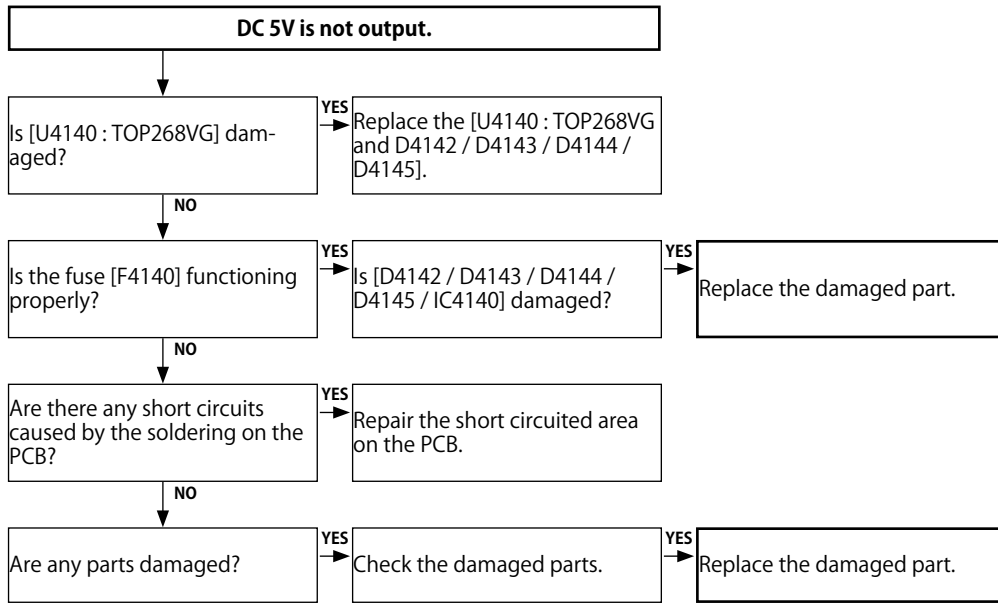

Operation waveform for each part

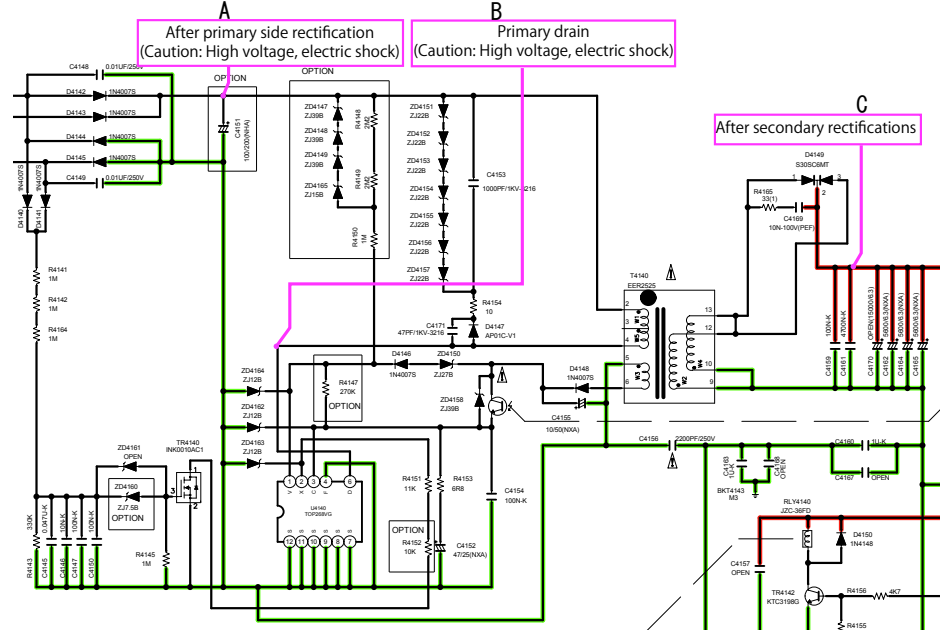

SMPS unit (Unloaded)

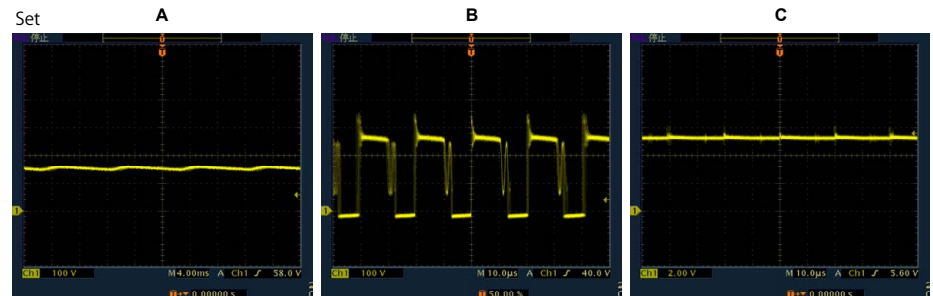
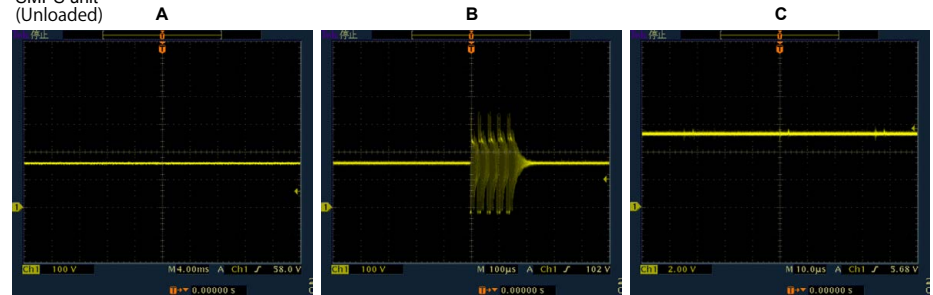

Caution in servicing

Electrical

Mechanical

Repair Information

Updating

HDMI "Rx/Tx" Failure Detection

1. Prior checking

Check item(0) : Checking the HDMI connector
Checking the condition of the HDMI pin (rear/front).

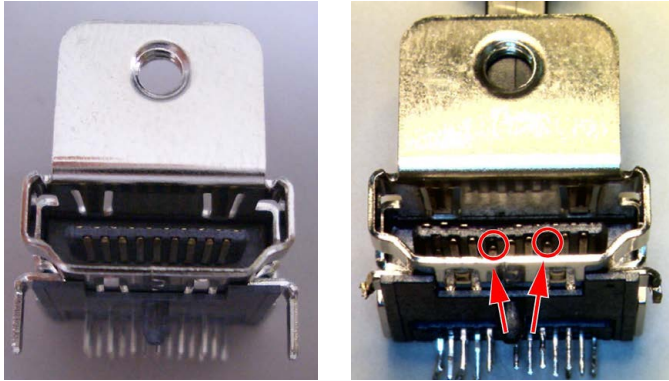

OK

NG

Check for deformed pins.

None of the pins are deformed.

There are deformed pins.

Replace the HDMI connector.

Check by following the flow chart for "3. Starting detecting the point of failure".

NOTE :

After checking troubleshooting "3. HDMI/DVI", check "3. Starting detecting the point of failure".

2. Preparations for checking HDMI Switcher reception/transmission register

2-1. Necessary devices

- 1) Check the product settings.
- 2-a) Player with an HDMI terminal
- 2-b) TV with an HDMI terminal (* NOTE : Do not use a computer monitor.)
- 3) Windows PC
- 4) Serial communication software "termite.exe"
(Download the software from http://www.comphase.com/software_termite.htm and install it.)
- 5) HDMI cable
- 6) RS-232C Straight cable
- 7) 8U-2120100S WRITING KIT
- 8) oscilloscope

2-2. Device Connection Method

Connect the TV and the AVR to the player using an HDMI cable and connect the AVR to the PC through an RS-232C cable as shown in Figure 1.

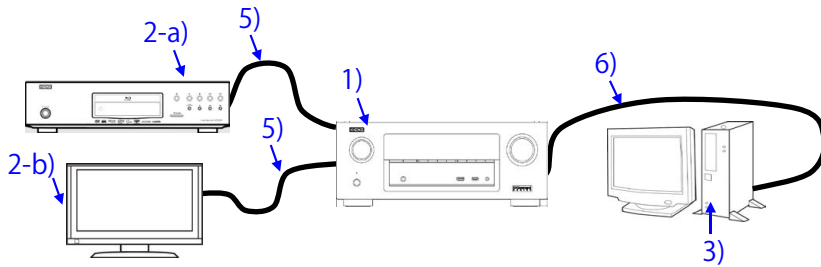

Figure 1-1 Device Connection Method (AVR-X2400H)

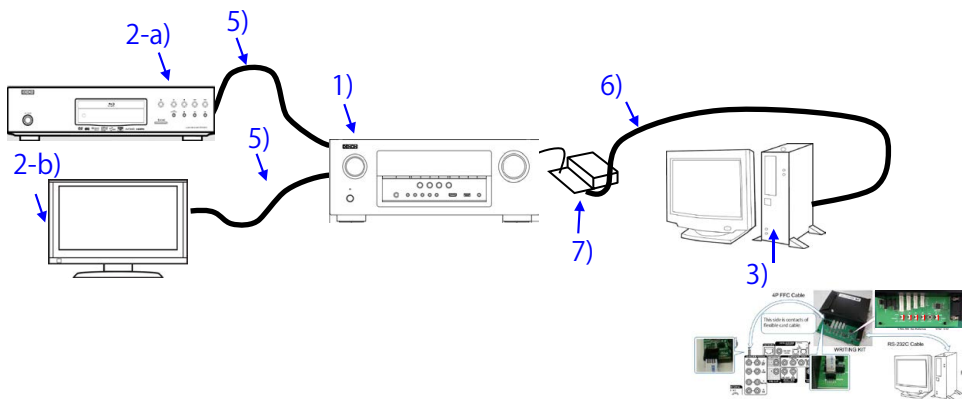

Figure 1-2 Device Connection Method (AVR-S930H)

2-3. Device configuration method

PC settings : Execute the serial communication program, Termite.exe.

After executing Termite.exe, click [Settings].

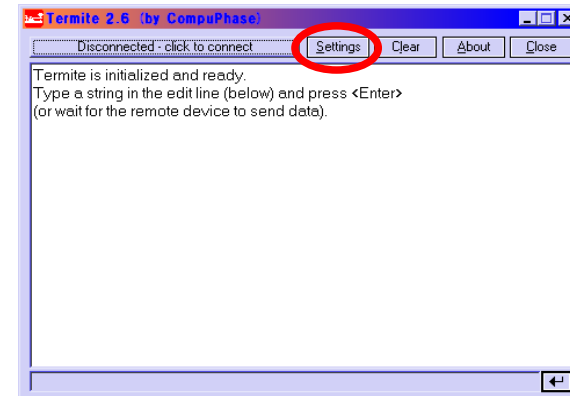

Figure 2 Screen After Executing Termite.exe

The serial port setup screen will be displayed. Configure the settings as shown in Figure 3 and click the "OK" button.

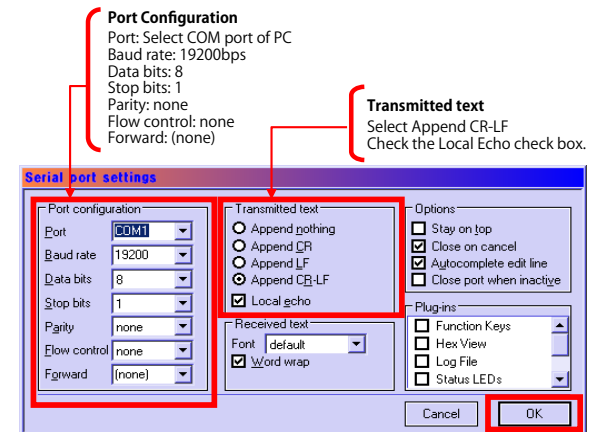

Figure 3 Serial Port Setup Screen

Click the [click to connect] button to start communication.
 After a connection is established successfully, the display of the button name will change as shown in Figure 4.

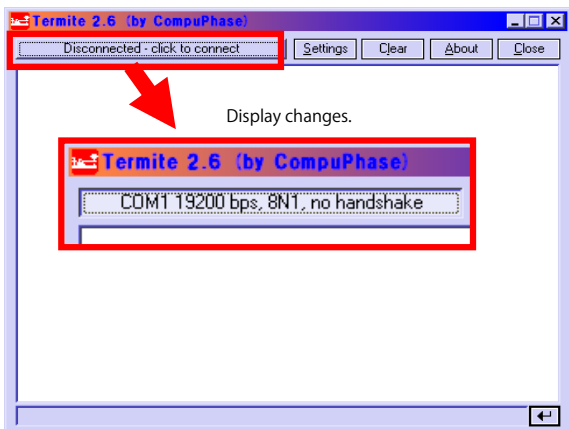

Figure 4 Change of the Display of the Communication Start Button Name

TV settings : Switch to the HDMI input in the AVR connection.
 Player settings : Turn the unit power on and configure it to play disks.
 AVR settings : While the power is On, hold down buttons "**PRESET UP**" and "**ZONE2 SOURCE**" for at least 3 seconds.
 (Continue to press and hold the buttons until all segments of the FLD volume illuminate.)
 ※ When the power is turned on after initialization, "**Setup Assistant**" will be displayed.
 After exiting "**Setup Assistant**" execute the above.

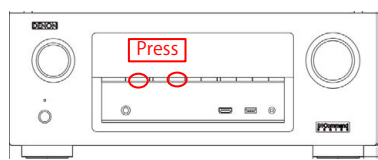

Figure 6-1. AVR settings (AVR-X2400H)

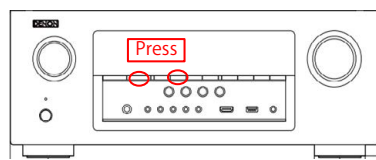

Figure 6-2. AVR settings (AVR-S930H)

for Volume 7 segment
 All the indicator Lights



Figure 6 FLD Display When Set

When the settings are correct, the following message will be displayed in the window of Termite.

```
[00]Start Sub CPU Log Mode
****
(**** is a version of Sub CPU.)
```

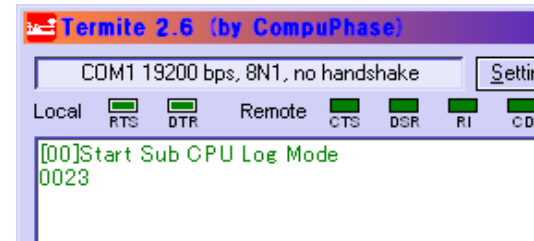

Figure 7 Display of Termite When AVR is Set

The setup is now complete.

Method for sending commands

Enter the command in the transmission command entry section, click the [Send] button and send the command.

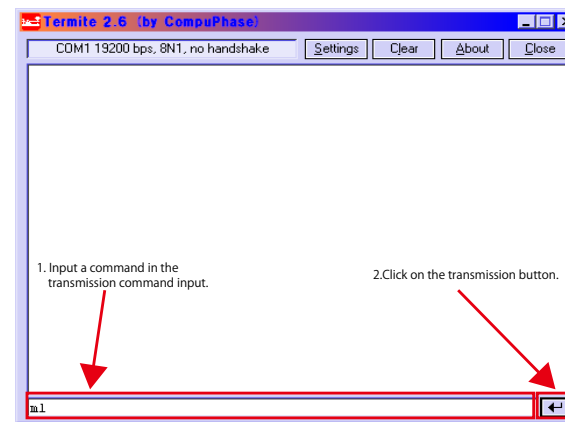

Figure 8 Method for Sending Termite Commands

3. Starting detecting the point of failure

Check item(1).

Check the power supply status and communication status with the CPU of each device.
Start in HDMI Diagnostics mode and follow the procedures below.

(1) Start in HDMI Diagnostics mode

While the power is on, hold down buttons "TUNER PRESET CH -" and "ZONE2 SOURCE" for at least 3 seconds.

HDMI DIAGNOSTICS

↓ "HDMI DIAGNOSTICS" is displayed.

When the mode has switched, start Hardware check.

Hardwarecheck...

↓

(2-1) Display when an Error Code is displayed.

Err: H1-XX

↓↑ Alternating display.

Contact support

Check the Error Code table items.

Error Code table

Error Code	Check item No.	Description
H1-01	Check item (6)	Communication Error with HDMI Tx [U1039 : MN864788]
H1-02	Check item (11)	Communication Error with HDMI SW1 [U1000 : MN864788]
H1-03	Check item (16)	Communication Error with HDMI SW2 [U1003 : MN864788]
H1-04	Check item (29)	Communication Error with TMDS SW [U1103 : TMDS261B]
H1-06	Check item (21)	Communication Error with GUI IC [U1026 : ADV8003]
H1-08	Check item (30)	Communication Error with DSP [U1073 : CS49844A]
H1-12	Check item (35)	Communication Error with DIR [U1040 : PCM9211]
H1-14	Check item (26)	DDR check Error [U1028, U1029 : A3R12E40DBF-8E]
H1-15	Check item (27)	Communication Error with GUI ROM [U1027 : W25Q128JVFIQ]

(2-2) Display when an Error is not detected.

HDMI DIAGNOSTICS

Cancel the mode, and proceed to [check item \(2\)](#).

Canceling the selected mode

Press the power button to exit off the power.

Check item(2) : Check operation of the HDMI input terminal.



When the HDMI input terminal of this device is connected to the player correctly, is sound heard from the speaker?

※ When checking, turn the AV amplifier on and off after checking the connection terminal with the player. (To set the same conditions during verification of operation)

Check that sound is heard from the input terminal of the HDMI 1-7.
Use any of Dolby TrueHD/DTSHD MA/PCM 8ch for the playback audio format.

NO
Is the "DIG" indicator illuminated on the FLD?
When the "DIG" indicator is illuminated, the digital audio block is faulty.
If the "DIG" indicator is not illuminated, go to [check item \(40\)](#).
(HDMI Rx IC [MN864788] failure detection procedure)

Check that sound is heard from the input terminal of the FRONT AUX.

NO
Go to [check item \(47\)](#)
(Front HDMI Buffer IC [AD8195] failure detection procedure)

Check item(3) :

- (1) Turn Video Conversion "OFF" on the setup menu.
(Setup Menu - Video - Output Settings - Video Conversion)
- (2) Does a video signal come from HDMI OUT1 to TV correctly?

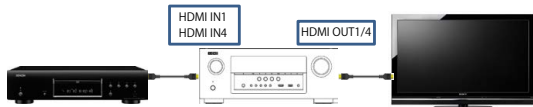

When the player is connected in order to the HDMI input terminals (HDMI 1, 4), in each case is the player video played back on the TV connected to the HDMI output terminal (HDMI OUT 1,2)?

NO
Go to [check item \(55\)](#)
HDMI transmission IC [MN864788] failure detection procedure

Check item(4) : Check operation of the HDMI output terminal.

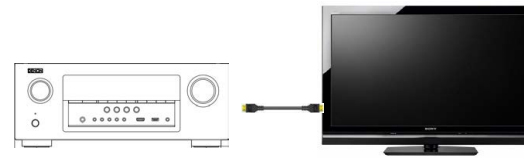

When the "SETUP" button on a remote control is pressed, is "MENU" displayed on TV which is connected to the HDMI output terminal on the AVR?

NO
Go to [check item \(72\)](#)
(GUI IC [ADV8003] failure detection procedure 2)

YES
Check item(5) :
(4)-1 Turn Video Conversion "ON" on the setup menu.
(Setup Menu - Video - Output Settings - Video Conversion)
(4)-2 Does a video signal come from HDMI OUT1 to TV correctly?

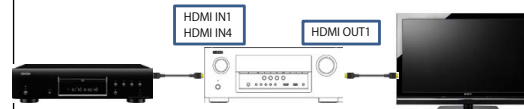

When the player is connected to the HDMI input terminals in order, are the images on the player displayed on the TV in both cases?

NO
Go to [check item \(74\)](#)
(HDMI SW IC [TMDS261B] failure detection procedure)

YES
There is no problem with Rx, Tx, and GUI of HDMI as well as IC of SW.

3-1. Error Code H1-01 failure detection procedure

Checking device. [U1039 : MN864788]

Check the power supply voltage. (HDMI Tx)

Check item(6). Check the power supply voltage. :
Does the power supply voltage of the HDMI Tx [U1039] indicate the correct voltage (1.1V, 3.3V)?
The test points are as follows.
HDMI Tx

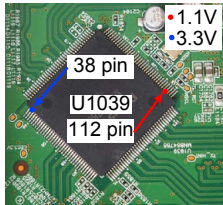

YES

NO

Check item(7). Check the power supply voltage. :
Check the power components [U1064/U1066] and the pattern on the substrate.
If there is no problem, remove the HDMI Switcher2 [U1039] from the substrate and measure the voltage at the test point of **check item (6)**.
Is the voltage correct (1.1 V or 3.3 V)?

YES

NO

Replace with a new device.

The power supply circuit is faulty.
Replace the PCB.

Recheck from **check item (1)**.
If it does not work, replace the PCB.

Checking the reset waveform. (HDMI Tx)

Check item(8). Checking the reset waveform :
Check the waveform.
Is the "RESET" waveform of the TP near the HDMI Tx [U1039] correct (like the one shown in the diagram) when the power is turned on?

HDMI Tx

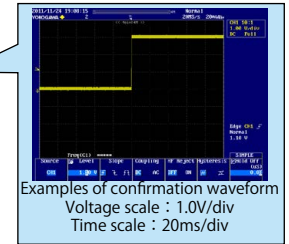
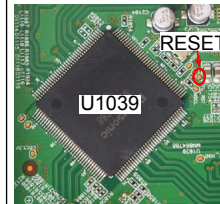

Examples of confirmation waveform
Voltage scale : 1.0V/div
Time scale : 20ms/div

NO

Check the reset circuit between CPU [U1018] and HDMI Tx [U1039].
If there is no problem, the HDMI Tx [U1039] is faulty.
Replace with a new device.
Recheck from **check item (1)**.
If it does not work, replace the PCB.

YES

Go to next page.

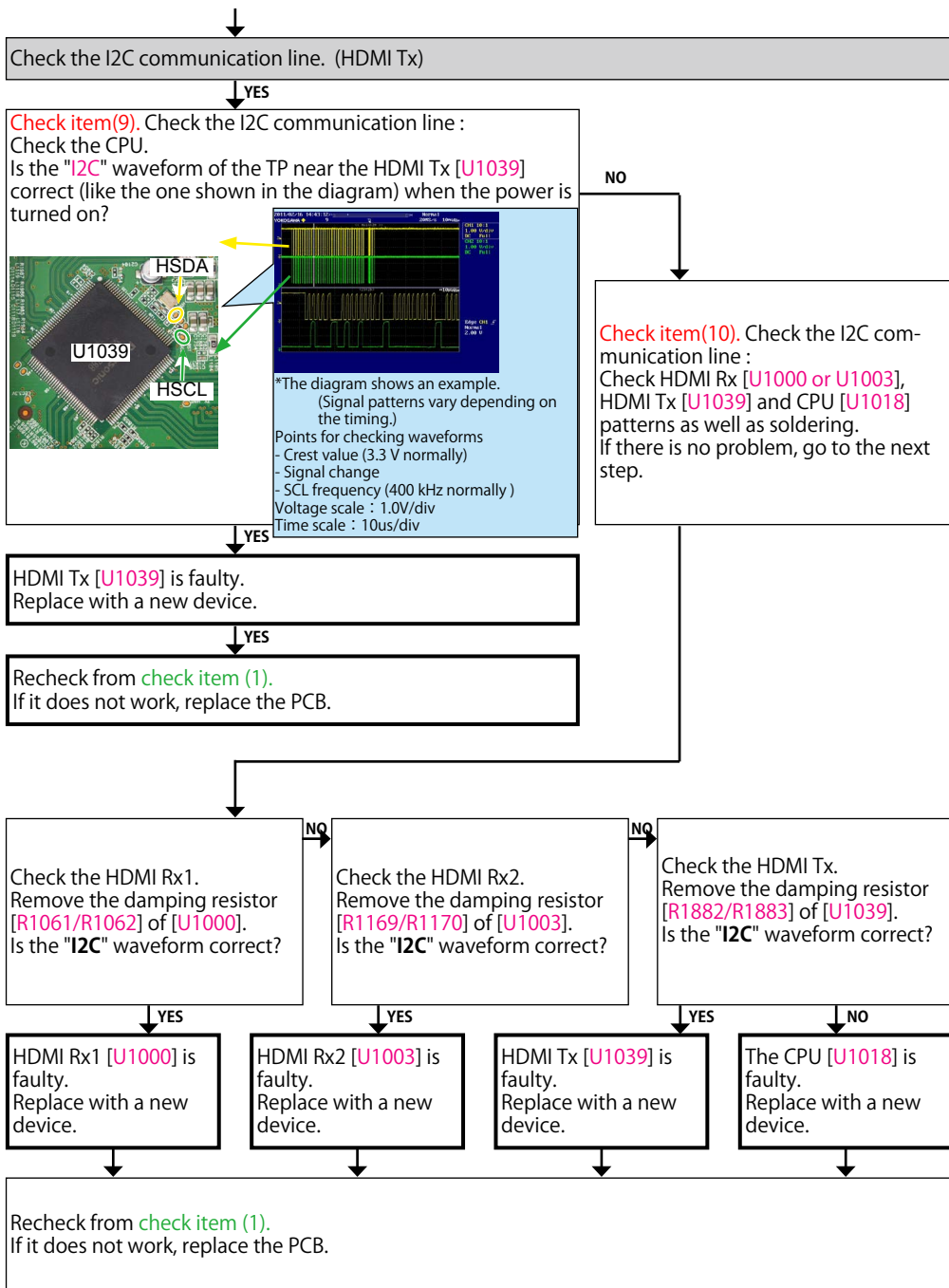

3-2. Error Code H1-02 failure detection procedure

Checking device. [U1000 : MN864788]

Check the power supply voltage. (HDMI Rx)

Check item(11). Check the power supply voltage. :
Does the power supply voltage of the HDMI Rx1 [U1000] indicate the correct voltage (1.1V, 3.3V)?
The test points are as follows.
HDMI Rx1

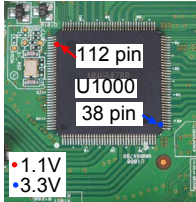

YES

NO

Check item(12). Check the power supply voltage. :
Check the power components [U1063/U1066] and the pattern on the substrate.
If there is no problem, remove the HDMI Rx [U1039] from the substrate and measure the voltage at the test point of **check item (11)**.
Is the voltage correct (1.1 V or 3.3 V)?

YES

NO

Replace with a new device.

The power supply circuit is faulty.
Replace the PCB.

Recheck from **check item (1)**.
If it does not work, replace the PCB.

Checking the reset waveform. (HDMI Rx)

Check item(13). Checking the reset waveform :
Check the waveform.
Is the "RESET" waveform of the TP near the HDMI Rx [U1000] correct (like the one shown in the diagram) when the power is turned on?
HDMI Rx1

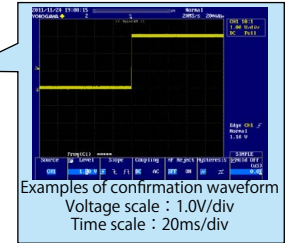
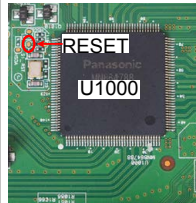

NO

Check the reset circuit between CPU [U1018] and HDMI Rx [U1001].
If there is no problem, the HDMI Rx [U1000] is faulty.
Replace with a new device.
Recheck from **check item (1)**.
If it does not work, replace the PCB.

YES

Go to next page.

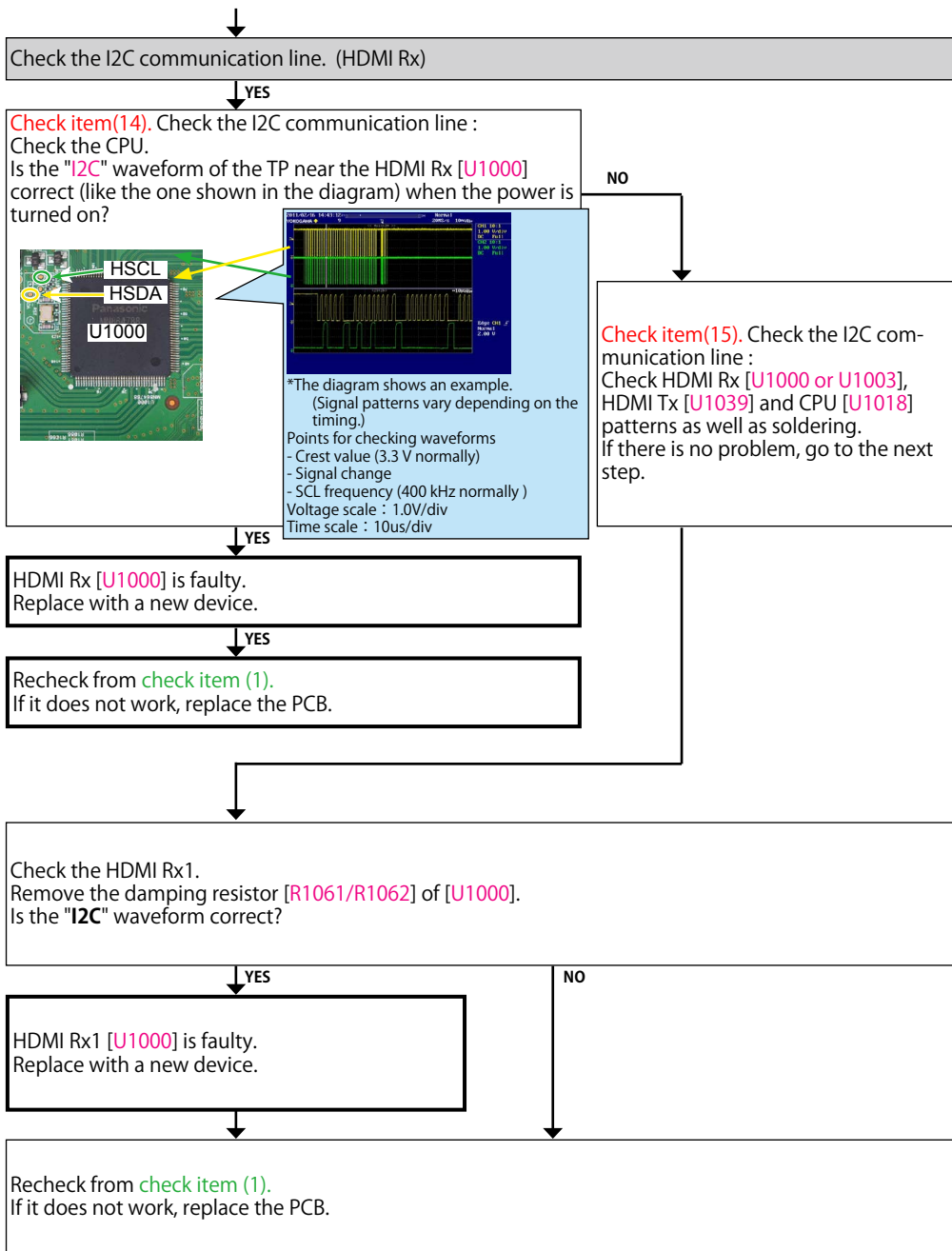

3-3. Error Code H1-03 failure detection procedure

Checking device. [U1003 : MN864788]

Check the power supply voltage. (HDMI Rx)

Check item(16). Check the power supply voltage. :
Does the power supply voltage of the HDMI Rx2 [U1003] indicate the correct voltage (1.1V, 3.3V)?
The test points are as follows.
HDMI Rx2

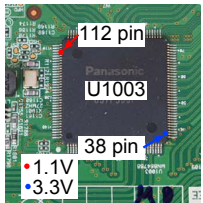

YES

NO

Check item(17). Check the power supply voltage. :
Check the power components [U1065] and the pattern on the substrate.
If there is no problem, remove the HDMI Rx [U1003] from the substrate and measure the voltage at the test point of **check item (16)**.
Is the voltage correct (1.1 V or 3.3 V)?

YES

NO

Replace with a new device.

The power supply circuit is faulty.
Replace the PCB.

Recheck from **check item (1)**.
If it does not work, replace the PCB.

Checking the reset waveform. (HDMI Rx)

Check item(18). Checking the reset waveform :
Check the waveform.
Is the "RESET" waveform of the TP near the HDMI Rx [U1003] correct (like the one shown in the diagram) when the power is turned on?
HDMI Rx2

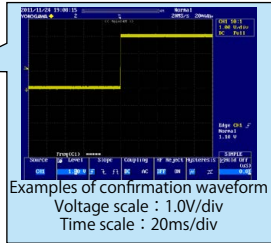
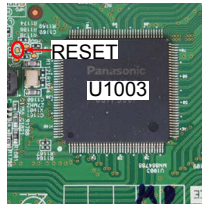

NO

Check the reset circuit between CPU [U1018] and HDMI Rx [U1003].
If there is no problem, the HDMI Rx [U1003] is faulty.
Replace with a new device.
Recheck from **check item (1)**.
If it does not work, replace the PCB.

YES

Go to next page.

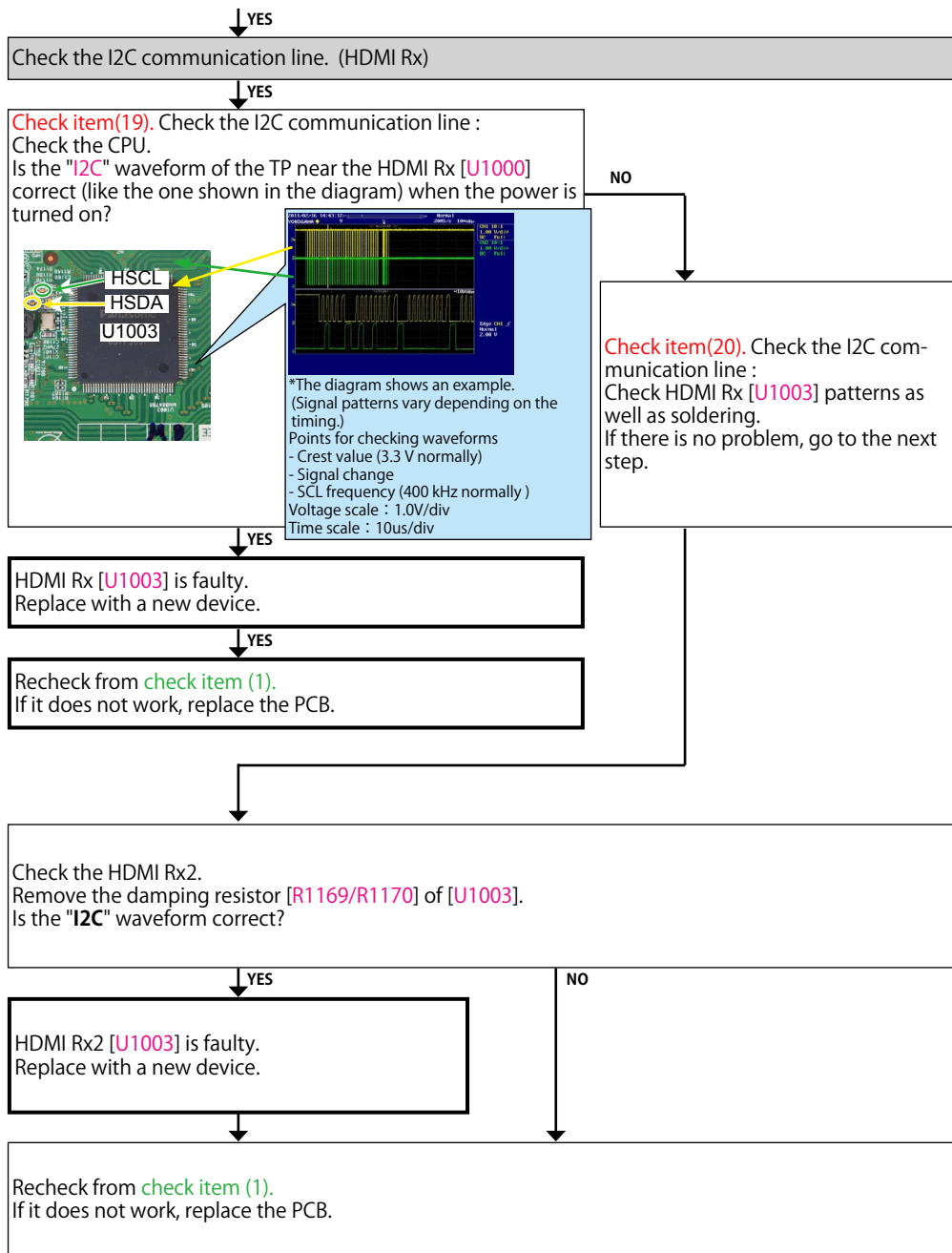

3-4. Error Code H1-06 failure detection procedure

Checking device. [U1026 : ADV8003]

Check the power supply voltage.

Check item(21). Check the power supply voltage.
: Does the power supply voltage of the GUI [U1026] indicate the appropriate voltage (1.8V, 3.3V)? The test points are as follows.

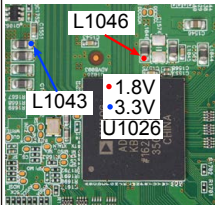

Check item(22). Check the power supply voltage.
: Check the power supply components [U1069, Q1063] on the substrate and peripheral pattern. If there is no problem, remove the GUI [U1026] from the substrate and measure the voltage at the test point of **check item (21)**. Is the voltage correct (1.8 V or 3.3 V)?

YES

YES

NO

The power supply circuit is faulty.
Replace the PCB.

The GUI [U1026] is faulty.
Replace with a new device.

Recheck from **check item (1)**.
If it does not work, replace the PCB.

Checking the reset waveform.

Check item(23). Checking the reset :
Check the CPU.
Is the waveform of the TP near the GUI [U1026] correct (like the one shown in the diagram) when the power is turned on?

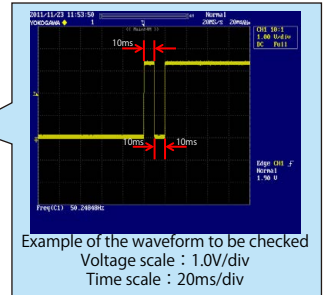
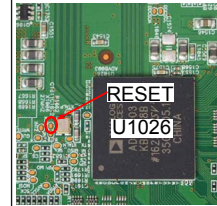

YES

NO

Check the reset circuit between CPU [U1018] and GUI [U1026].
If there is no problem, the GUI [U1026] is faulty.
Replace with a new device.

Recheck from **check item (1)**.
If it does not work, replace the PCB.

Go to next page.

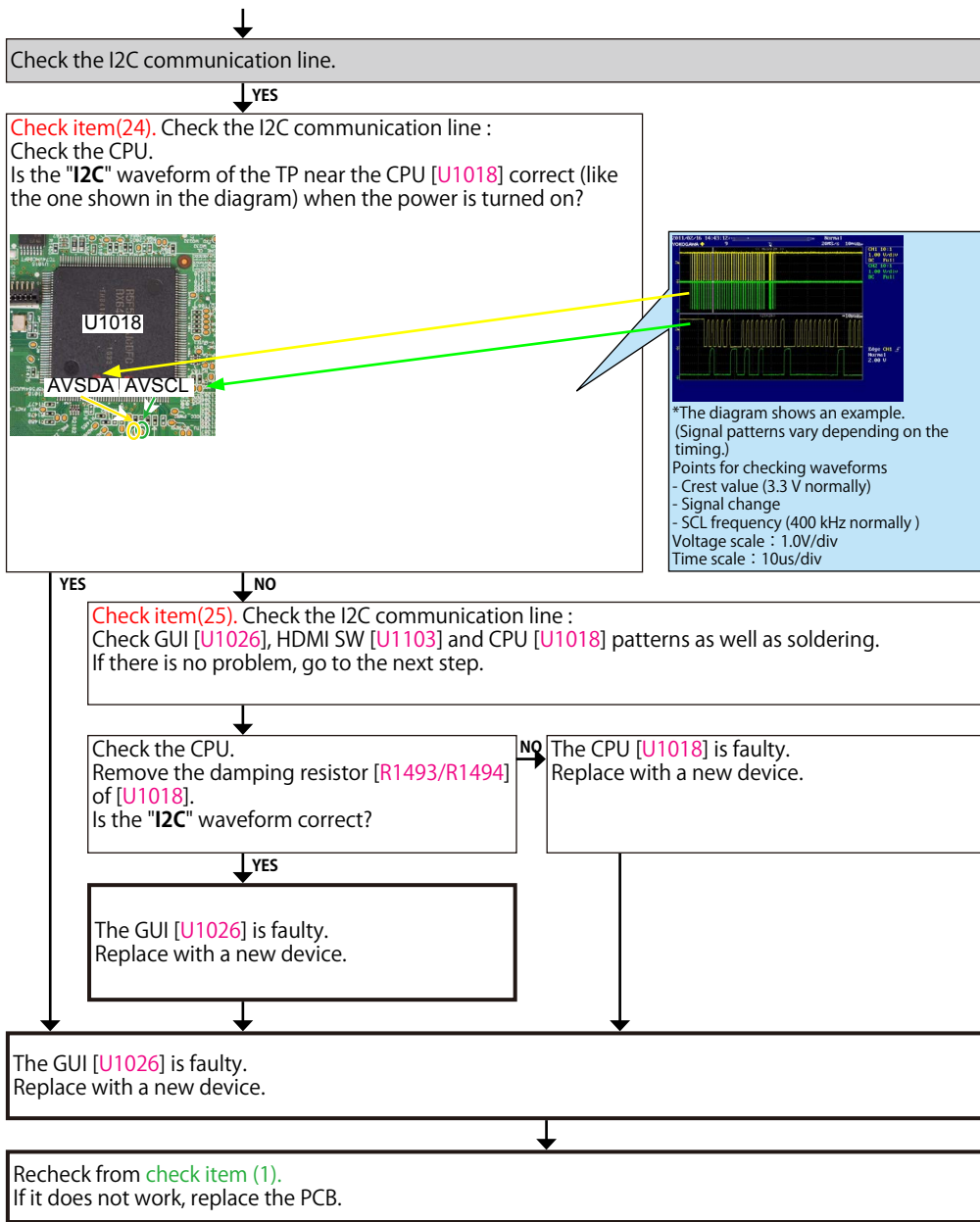

3-5. Error Code H1-14 failure detection procedure

Checking device. [U1028, U1029 : A3R12E40DBF-8E]

Check item(26).

Check soldering of IP SCALER [U1026], DDR2 [U1028/U1029] and its peripheral circuits.
Check soldering of the resistors [R1688/1689/1692/1695 to 1700/1703 to 1711] between IP SCALER and DDR2.
If there is no problem with soldering, [U1026/U1028/U1029] is defective. Replace their IC. Or replace the substrate.

3-6. Error Code H1-15 failure detection procedure

Checking device. [U1027 : W25Q128JVFIQ]

Check item(27).

Write to the GUI ROM.

Recheck from [check item \(1\)](#)
Does Error Code H1-15 continue?

NO

YES

Check item(28).

Replace [U1029] with a new device.

Recheck from [check item \(1\)](#)
Does Error Code H1-15 continue?

NO

YES

Go to [check item \(21\)](#)

Recheck from [check item \(2\)](#).

3-7. Error Code H1-04 failure detection procedure

Checking device. [U1103 : TMDS261B]

Check item(29).
Replace [U1103] with a new device.
Recheck from check item (1)
Does Error Code H1-04 continue?

NO

YES

Replace the PCB.

Recheck from check item (2).

3-8. Error Code H1-08 failure detection procedure

Checking device. [U1073 : CS49844A]

Check the power supply voltage.

Check item(30). Check the power supply voltage.
Does the power supply voltage of the DSP [U1073] indicate the appropriate voltage (1.0V, 3.3V)?
The test points are as follows.

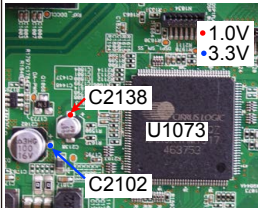

Check item(31). Check the power supply voltage.
Check the power supply components [U1067, U1068, Q1067] on the substrate and peripheral pattern.
If there is no problem, remove the DSP [U1073] from the substrate and measure the voltage at the test point of **check item (21)**.
Is the voltage correct (1.0 V or 3.3 V)?

Checking the reset waveform.

Check item(32). Checking the reset :
Check the CPU.
Is the waveform of the TP near the DSP [U1073] correct (like the one shown in the diagram) when the power is turned on?

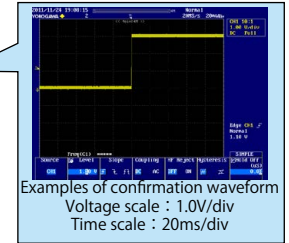
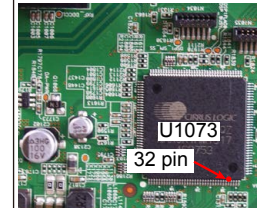

YES

YES

NO

YES

NO

The power supply circuit is faulty.
Replace the PCB.

The DSP [U1073] is faulty.
Replace with a new device.

Check the reset circuit between CPU [U1018] and DSP [U1073].
If there is no problem, the DSP [U1073] is faulty.
Replace with a new device.

Recheck from **check item (1)**.
If it does not work, replace the PCB.

Recheck from **check item (1)**.
If it does not work, replace the PCB.

Go to next page.

↓
Check the SPI communication line.

↓ YES

Check item(33). Check the SPI communication line :
Check the CPU.
Is the "SPI" waveform of the TP near the DSP [U1073] correct (like the one shown in the diagram) when the power is turned on?

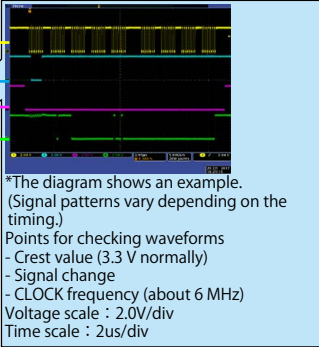
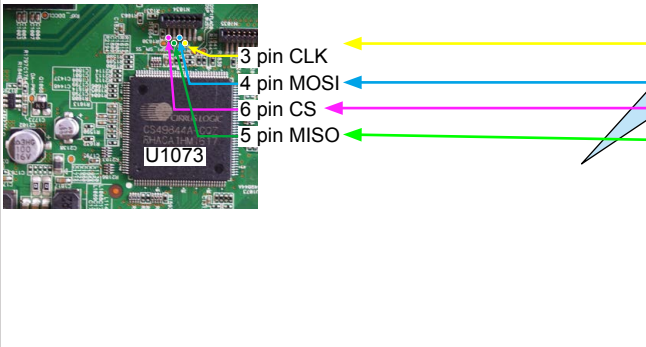

YES ↓ NO

Check item(34). Check the SPI communication line :
Check DSP [U1073] and CPU [U1018] patterns as well as soldering.
If there is no problem, go to the next step.

↓ YES ↓ NO

The DSP [U1073] is faulty.
Replace with a new device.

↓

Recheck from **check item (1)**.
If it does not work, replace the PCB.

3-9. Error Code H1-12 failure detection procedure

Checking device. [U1040 : PCM9211]

Check the power supply voltage.

Check item(35). Check the power supply voltage.
: Does the power supply voltage of the DIR [U1040] indicate the appropriate voltage (3.3V)?
The test points are as follows.

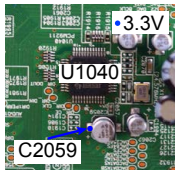

Check item(36). Check the power supply voltage.
: Check the power supply components [U1067, Q1067] on the substrate and peripheral pattern. If there is no problem, remove the DIR [U1040] from the substrate and measure the voltage at the test point of **check item (35)**.
Is the voltage correct (3.3 V)?

YES

YES

NO

The power supply circuit is faulty.
Replace the PCB.

The DIR [U1040] is faulty.
Replace with a new device.

Recheck from **check item (1)**.
If it does not work, replace the PCB.

Checking the reset waveform.

Check item(37). Checking the reset :
Check the CPU.
Is the waveform of the TP near the DIR [U1040] correct (like the one shown in the diagram) when the power is turned on?

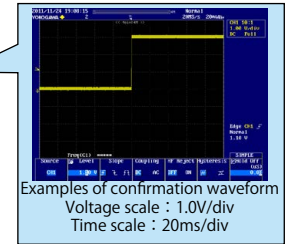
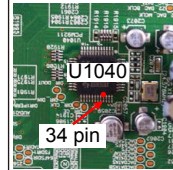

YES

NO

Check the reset circuit between CPU [U1018] and DIR [U1040].
If there is no problem, the DIR [U1040] is faulty.
Replace with a new device.

Recheck from **check item (1)**.
If it does not work, replace the PCB.

Go to next page.

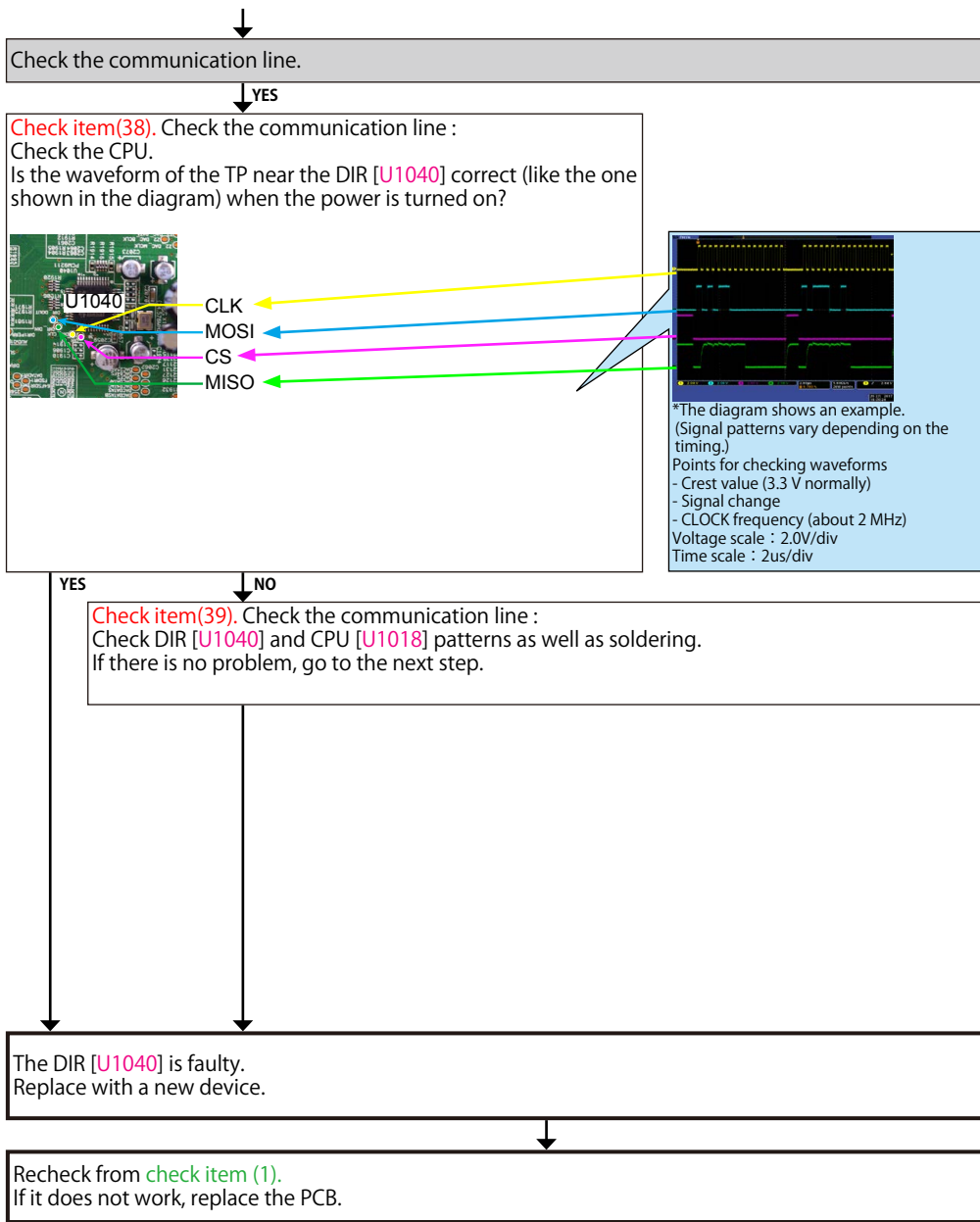

3-10. HDMI Rx [MN864788] failure detection procedure

Checking operation between the HDMI (Rx) device and the player



※ In order to check, connect the player to the HDMI terminal and configure the player as AVR source. Check the sound output while turning on the player.

Checking the +5V/DDC status register (HDMI Rx)

Check item(40). Checking the 5V status register :
Send the following command from Termite.exe.

HDMI Rx1 (When checking HDMI inputs 1, 2, and 3)
Send the command "i 002E 00FF 0001".
HDMI Rx2 (When checking HDMI inputs 4, 5, 6, and 7)
Send the command "i 0056 00FF 0001".

Move to the branch destination according to the value returned.

Example

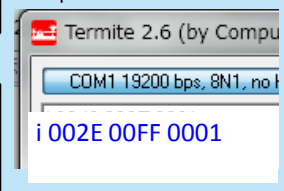

HDMI in 1 ~ 7 "00"
(Detection of 5V is not OK.)

Go to **check item (42)**

HDMI in1 "44 or 40" HDMI In2 "22 or 20" HDMI In3 "11 or 10"
HDMI In4 "88 or 80" HDMI In5 "44 or 40" HDMI In6 "22 or 20"
HDMI In7 "11 or 10"
(Detection of 5V is OK)

Check item(41). Checking the +5V/DDC status register :
Send the following command from Termite.exe.

HDMI Rx1 (When checking HDMI inputs 1, 2, and 3)
Case of HDMI IN1
Send the command "i 002B 0084 0001".
Case of HDMI IN2
Send the command "i 002B 0054 0001".
Case of HDMI IN3
Send the command "i 002B 0024 0001".

HDMI Rx2 (When checking HDMI inputs 4, 5, 6, and 7)
Case of HDMI IN4
Send the command "i 0053 00B4 0001".
Case of HDMI IN5
Send the command "i 0053 0084 0001".
Case of HDMI IN6
Send the command "i 0053 0054 0001".
Case of HDMI IN7
Send the command "i 0053 0024 0001".

Move to the branch destination according to the value returned.

Example

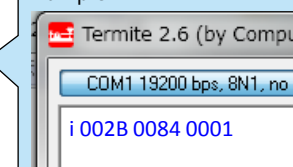

"00 or 04"
(Detection of DDC is not OK.)

Go to **check item (43)**

"22"
(Detection of DDC is OK)

Go to **check item (44)**

When the results of check item (40) are "00"
(Detection of 5V is not OK)

Check the +5V voltage. (HDMI Rx)

Check item(42). Check the +5V voltage.
Does "+5V" at the following test point indicate 5 V?

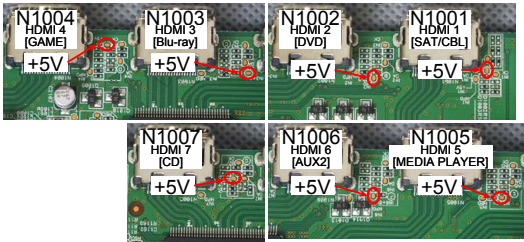

YES

HDMI Rx [U1000 or U1003] is faulty.
Replace with a new device.

Recheck from check item (2).
If it does not work, replace the PCB.

NO

Check for a short circuit in the 5 V line and the 5 V Switch IC [U1002].
If there is no problem, the HDMI Rx [U1000 or U1003] or the 5 V Switch IC [U1002] is faulty.
Replace with a new device.

When the results of check item (41) are "00 or 04"
(Detection of DDC is not OK.)

Check the DDC line. (HDMI Rx)

Check item(43). Check the DDC line :
Are waveforms of "DDCCLK" and "DDCSDA" observed at the test point near the HDMI input terminal?

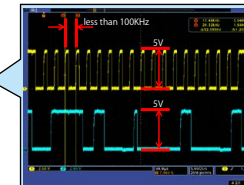
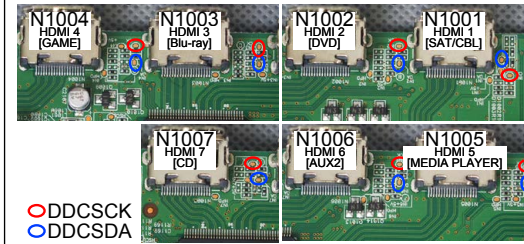

This diagram shows an example of the DDC communication waveform.
-The high level voltage is 5V.
-The frequency of the DDC CLK is 100 KHz or less.
Check at each test point.
Voltage scale : 2.0V/div
Time scale : 40us/div

YES

HDMI Rx [U1000 or U1003] is faulty.
Replace with a new device.

Recheck from check item (2).
If it does not work, replace the PCB.

NO

Check for a short circuit in the DDC line.
If there is no problem, the HDMI Rx1 [U1000] or HDMI Rx2 [U1003] is faulty.
Replace with a new device.

When the results of check item (41) are "22"
(Detection of DDC is OK.)

Checking the TMDS status register

Check item(44). Checking register of the TMDS CLK detection status register:
Send the following command from Termit.exe.

HDMI Rx1 (When checking HDMI inputs 1, 2, and 3)
Send the command "i 002E 00FF 0001".
Rx2 (When checking HDMI inputs 4, 5, 6, and 7)
Send the command "i 0056 00FF 0001".

When the following value is returned, go to Yes.
HDMI In1 "44" HDMI In2 "22" HDMI In3 "11" HDMI In4 "88" HDMI In5
"44" HDMI In6 "22" HDMI In7 "11"

When the following value is returned, go to No.
HDMI In1 "40" HDMI In2 "20" HDMI In3 "10" HDMI In4 "80" HDMI In5
"40" HDMI In6 "20" HDMI In7 "10"

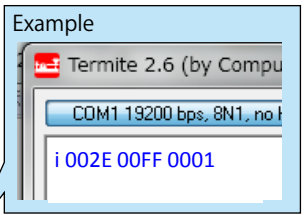

NO

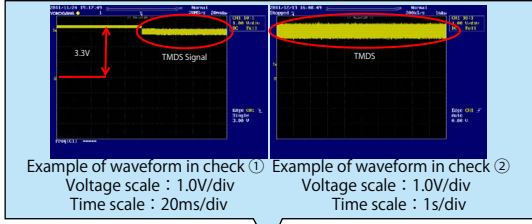

Example of waveform in check ① Voltage scale : 1.0V/div Time scale : 20ms/div
Example of waveform in check ② Voltage scale : 1.0V/div Time scale : 1s/div

Check item (46). Checking the TMDS input waveform :
Check the TMDS waveform at the following test point.
Is the waveform like the sample?

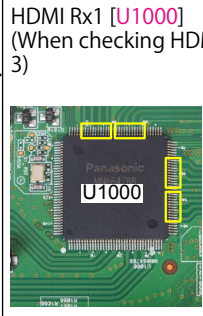

- HDMI In3/7
93/94/96/97/99/100/102/103 pin
- HDMI In2/6
80/81/83/84/86/87/89/90 pin
- HDMI In1/5
55/56/58/59/61/62/64/65 pin
- HDMI In4
42/43/45/46/48/49/51/52 pin

YES

NO

HDMI Rx [U1000 or U1003] is faulty.
Replace with a new device.

Check for a short circuit in the pattern of the
TMDS line of the HDMI Rx [U1000 or U1003] from
the HDMI input terminal.
If there is no problem, the HDMI Rx [U1000 or
U1003] is faulty. Replace with a new device.

Recheck from **check item (2)**.
If it does not work, replace the PCB.

Check item(45). Checking the audio signal output :
Check the audio signal waveform at the following test point.
Is the waveform like the sample?

HDMI Rx1 [U1000]
(When checking HDMI inputs
1, 2, and 3)

HDMI Rx2 [U1003]
(When checking HDMI inputs
4, 5, 6, and 7)

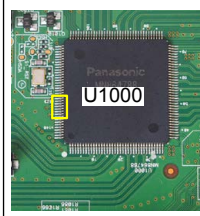

129/131/132/133/134/135/136 pin

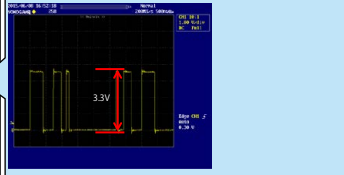

The diagram shows an example of the wave-
form of pin 129. (I2S0 Data)
Waveform check points
- Crest value (3.3 V normally)
- Signal change
Check the waveform of each pin.
Voltage scale : 1.0V/div
Time scale : 500ns/div

YES
The digital audio block is faulty.
Check the digital audio device.
Check "AUDIO" in troubleshooting.
If it does not work, replace the PCB.

NO
HDMI Rx [U1000 or U1003] is faulty.
Replace with a new device.

3-11. Front HDMI Buffer IC [AD8195] failure detection procedure

Checking operation between the HDMI (Front HDMI Buffer) and the player



※ In order to check, connect the player to the HDMI terminal and configure the player as AVR source. Check the sound output while turning on the player.

Check the power supply voltage. (HDMI Rx)

Check item(47). Check the power supply voltage. : Does the power supply voltage of the Front HDMI FFC base [N1000] indicate the correct voltage (5V)? The test points are as follows.

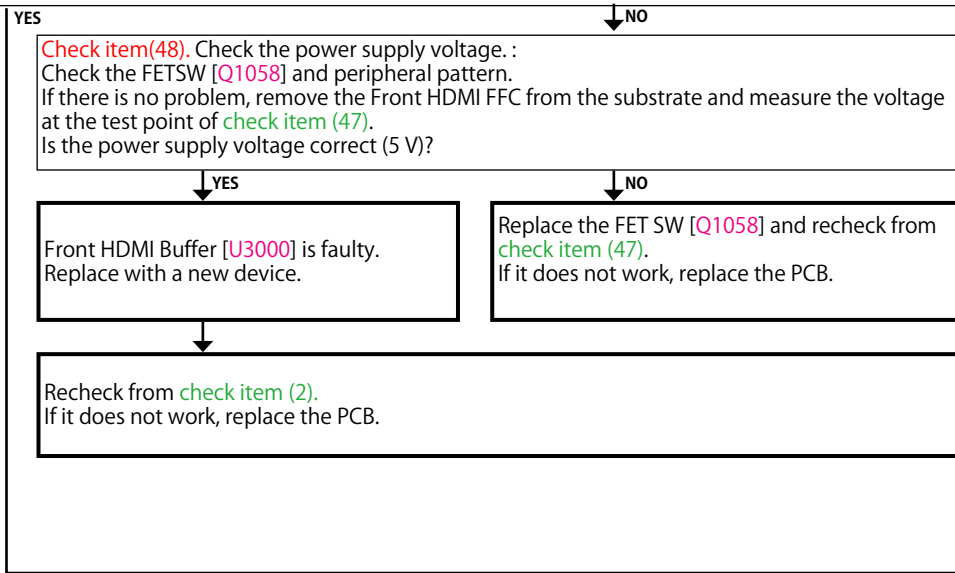
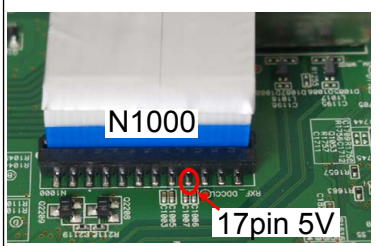

Checking the +5V/DDC status register (Front HDMI Buffer)

Check item(49). Checking the 5V status of the register : Send the following command from Termit.exe.
Send the command "i 002E 00FF 0001".
Move to the branch destination according to the value returned.

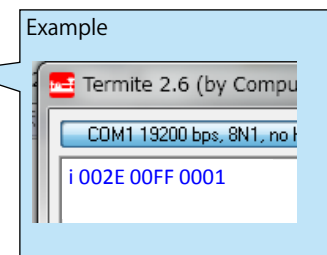

"00"
(Detection of 5V is not OK.)

Go to check item (51)

"88 or 80"
(Detection of 5V is OK)

Check item(50). Checking the status of the register : Send the following command from Termit.exe.
Send the command "i 002B 00B4 0001".
Move to the branch destination according to the value returned.

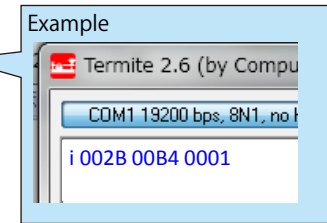

"00 or 04"
(Detection of DDC is not OK.)

Go to check item (51)

"22"
(Detection of DDC is OK.)

Go to check item (53)

Caution in servicing

Electrical

Mechanical

Repair Information

Updating

When the results of check item (49) are "00"
(Detection of 5V is not OK.)

Check the +5V voltage. (Front HDMI Buffer)

Check item(51). Check the +5V voltage :
Does "+5 V" at the following test point indicate 5 V?
The test points are as follows.

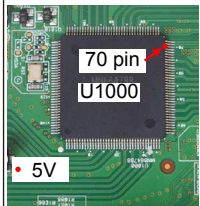

NO
Check for a short circuit in the 5 V line, the Front HDMI FFC, and the 5 V Switch [U1002].
If there is no problem, the HDMI Rx1 [U1000] or the 5 V Switch [U1002] is faulty.
Replace with a new device.

YES
HDMI Rx1 [U1000] is faulty.
Replace with a new device.

Recheck from check item (2).
If it does not work, replace the PCB.

When the results of check item (50) are "00 or 04"
(If the DDC are not OK)

Check the DDC line. (Front HDMI Buffer)

Check item(52). Check the DDC line :
Does "DDCCL / DDCDA" signal of the Rx1 [U1000] indicate 5 V?
The test points are as follows.

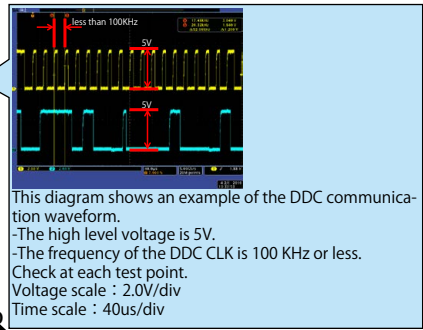
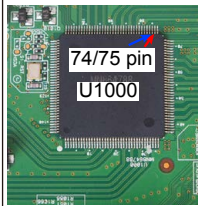

NO
Check for a short circuit in the DDC line and check the Front HDMI FFC.
If there is no problem, the Front HDMI Buffer [U3000] is faulty.
Replace with a new device.

YES
HDMI Rx1 [U1000] is faulty.
Replace with a new device.

Recheck from check item (2).
If it does not work, replace the PCB.

When the results of check item (50) are "22"
(Detection of DDC is OK)

Checking the TMDS status register

Check item(53). Check the TMDS CLK detection status of the register. :
Send the following command from Termite.exe.
Send the command "i 002E 00FF 0001".
When the following value is returned, go to Yes.
"88"
When the following value is returned, go to No.
"80"

Example

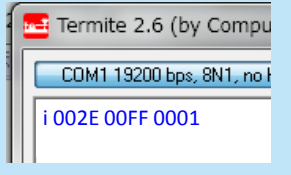

COM1 19200 bps, 8N1, no f...
i 002E 00FF 0001

NO

YES

HDMI Rx1 [U1000] is faulty.
Replace with a new device.

HDMI Rx1 [U1000] is faulty.
Replace with a new device.

Check for a short circuit in the TMDS line and the Front HDMI FFC.
If there is no problem, the Front HDMI Buffer [U3000] is faulty.
Replace with a new device.

Recheck from **check item (2)**.
If it does not work, replace the PCB.

Check item (54). Checking the TMDS input waveform. :
Check the TMDS waveform at the following test point.
Is the waveform like the sample?
HDMI Rx1 [U1000]

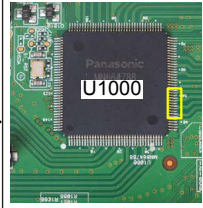

42/43/45/46/48/49/51/52 pin

YES

NO

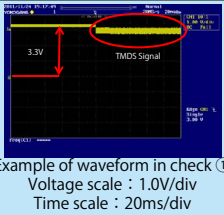

Example of waveform in check ①
Voltage scale : 1.0V/div
Time scale : 20ms/div

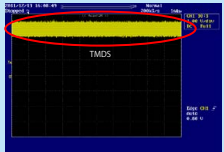

Example of waveform in check ②
Voltage scale : 1.0V/div
Time scale : 1s/div

3-12. HDMI transmission IC [MN864788] failure detection procedure

Check the output terminal.

Check item(55). Check the video output port for failure. :
Check the Monitor 1 output video signal is correct.

After checking the Monitor 1, change the HDMI cable connection from OUT1 to OUT2.
Turn off the AV AMP and turn it on again.
To check under the same conditions, use the same procedure as that for checking Monitor 1 when checking the Monitor 2 output.

No video signal is output from both Monitor 1 and Monitor 2.

Go to [check item \(56\)](#)

No video signal is output from Monitor 1 only.

Go to [check item \(58\)](#)

No video signal is output from Monitor 2 only.

Go to [check item \(65\)](#)

When the results of check item (55) are "No video signal is output from both Monitor 1 and Monitor 2".

Checking operation between the HDMI (Rx) device and the HDMI device (Tx).
Checking operation between the HDMI (Tx) device and TV.

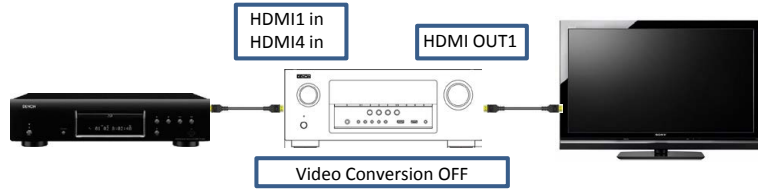

Checking the TMDS status register (HDMI Rx -> HDMI Tx)

Check item(56). Check the TMDS CLK detection status of the register.

Send the following command from Termit.exe.

Send the command "i 0006 00FF 0001".

When checking the signal path from HDMI1 to HDMI OUT1

"72" : Go to Yes.

"74" : Go to No.

When checking the signal path from HDMI4 IN to HDMI OUT1

"71" : Go to Yes.

"74" : Go to No.

NO

Check item (57). Checking the TMDS input :
TMDS waveform at the following points.

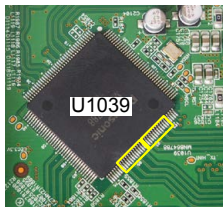

Between HDMI Rx1 and HDMI Tx
80/81/83/84/86/87/89/90 pin

Between HDMI Rx2 and HDMI Tx
93/94/96/97/99/100/102/103 pin

NO

HDMI Tx [U1039] is faulty.
Replace with a new device.

YES

Recheck from [check item \(3\)](#).
If it does not work, replace the PCB.

Example

```

Termite 2.6 (by Compu
COM1 19200 bps, 8N1, no f
i 0006 00FF 0001
    
```

YES
The first operation : Checking
between Monitor 1 and the TV.
Go to [check item \(58\)](#)
Next operation : Checking be-
tween Monitor 2 and the TV.
Go to [check item \(65\)](#)

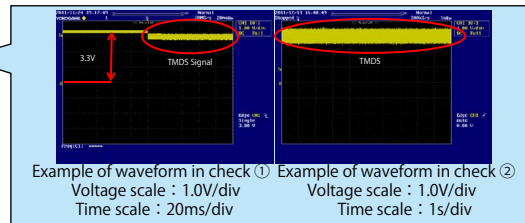

Checking between Monitor1 and the TV.
Connect Monitor1 to the TV and check the following items with the TV turned on.

Checking the HPD/RXSENSE status register. (HDMI TX -> Monitor)

Check item(58). Check the HPD and RXSENSE register value of
the HDMI TX device. :

Send the following command from Termit.exe.

Send the command "i 0000 0040 0001".

Move to the branch destination according to the value returned.

Example

```

Termite 2.6 (by Compu
COM1 19200 bps, 8N1, no f
i 0000 0040 0001
    
```

"30"

(Detection of HPD is OK / Detection of RXSENSE is OK)

Go to [check item \(59\)](#)

"10"

(Detection of HPD is OK / Detection of RXSENSE is not OK)

Go to [check item \(62\)](#)

"20"

(Detection of HPD is not OK / Detection of RXSENSE is OK)

Go to [check item \(63\)](#)

"00"

(Detection of HPD is not OK / Detection of RXSENSE is not OK)

Go to [check item \(64\)](#)

When the results of check item (58) are "30"
(Detection of HPD is OK / Detection of RXSENSE is OK)

Checking the EDID register. (Monitor1)

Check item(59). Check the Monitor EDID :
 ① Unplug the AC cord. Plug the AC cord into a power outlet.
 ② Send the transmission command "m_1" from Termite.exe.
 Are the first eight bytes of the returned value "00FFFFFFFFF00"?

Example

The first eight bytes are normally "00FFFFFFFFF00".
 *If the AVR and the TV are not connected via HDMI, the correct register value cannot be verified.

↓ YES

Check item(60). Checking the TMDS :
 Check the TMDS waveform at the following test point.

↓ NO

Check item(61). Check the communication :
 Are waveforms of "DDCCLK and DDCSDA" observed at the test point near the HDMI output terminal [N1031]?

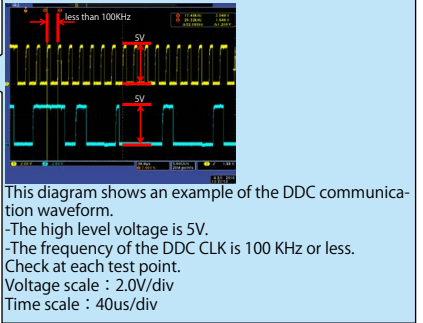

↓ YES

Check for a short circuit in the TMDS line.
 If there is no problem, the HDMI Tx [U1039] is faulty.
 Replace with a new device.

↓ NO

Check for a short circuit in the DDC line.
 If there is no problem, the HDMI Tx [U1039] is faulty.
 Replace with a new device.

HDMI Tx [U1039] is faulty.
 Replace with a new device.

HDMI Tx [U1039] is faulty.
 Replace with a new device.

Recheck from **check item (3)**.
 If it does not work, replace the PCB.

When the results of check item (58) are "10"
(Detection of HPD is OK / Detection of RXSENSE is not OK)

Check the RXSENSE. (Monitor1)

Check item(62). Checking the RXSENSE. :
Does the test point of RXSENSE close to the HDMI output terminal [N1031] indicate the 3.3 V?

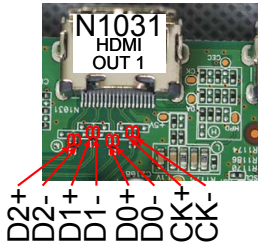

YES NO

Check for a short circuit in the TMDS line.
If there is no problem, the HDMI Tx [U1039] is faulty.
Replace with a new device.

HDMI Tx [U1039] is faulty.
Replace with a new device.

Recheck from check item (3).
If it does not work, replace the PCB.

When the results of check item (58) are "20"
(Detection of HPD is not OK / Detection of RXSENSE is OK)

Check the HPD. (Monitor1)

Check item(63). Checking the HPD. :
Does the voltage of HPD test point close to the HDMI output terminal [N1031] indicate Hi (3-5 V)?

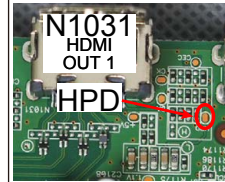

YES NO

Check for a short circuit in the HPD line.
If there is no problem, the HDMI Tx [U1039] is faulty.
Replace with a new device.

HDMI Tx [U1039] is faulty.
Replace with a new device.

Recheck from check item (3).
If it does not work, replace the PCB.

When the results of check item (58) are "00"
(Detection of HPD is not OK / Detection of RXSENSE is not OK)

Check the RXSENSE/HPD. (Monitor1)

Check item(64). Checking the HPD and RXSENSE. :
Does the test point of RXSENSE close to the HDMI output terminal [N1031] indicate the 3.3 V?
Does the voltage of HPD test point close to the HDMI output terminal [N1031] indicate Hi (3-5 V)?

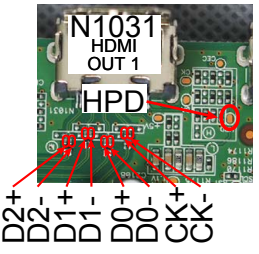

YES NO

Check for a short circuit in the TMDS/ HPD line.
If there is no problem, the HDMI Tx [U1039] is faulty.
Replace with a new device.

HDMI Tx [U1039] is faulty.
Replace with a new device.

Recheck from **check item (3)**.
If it does not work, replace the PCB.

Checking between Monitor 2 and the TV.
Connect Monitor2 to the TV and check the following items with the TV turned on.

Checking the HPD/RXSENSE status register. (Monitor2)

Check item(65). Check the HPD and RXSENSE register value of the HDMI TX device. :
Send the following command from Termit.exe.
Send the command "i 0000 0040 0001".
Move to the branch destination according to the value returned.

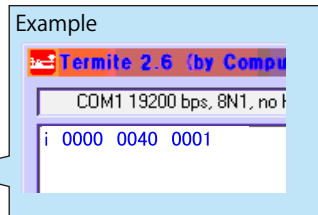

"03"
(Detection of HPD is OK / Detection of RXSENSE is OK)

Go to **check item (66)**

"01"
(Detection of HPD is OK / Detection of RXSENSE is not OK)

Go to **check item (69)**

"02"
(Detection of HPD is not OK / Detection of RXSENSE is OK)

Go to **check item (70)**

"00"
(Detection of HPD is not OK / Detection of RXSENSE is not OK)

Go to **check item (71)**

When the results of check item (65) are "01"
(Detection of HPD is OK / Detection of RXSENSE is not OK)

Check the RXSENSE. (Monitor2)

Check item(69). Checking the RXSENSE. :
Does the test point of RXSENSE close to the HDMI output terminal [N1030] indicate the 3.3 V?

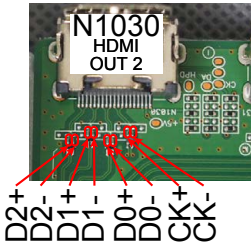

YES NO

Check for a short circuit in the TMDS line.
If there is no problem, the HDMI Tx [U1039] is faulty.
Replace with a new device.

HDMI Tx [U1039] is faulty.
Replace with a new device.

Recheck from check item (3).
If it does not work, replace the PCB.

When the results of check item (65) are "02"
(Detection of HPD is not OK / Detection of RXSENSE is OK)

Check the HPD. (Monitor2)

Check item(70). Checking the HPD. :
Does the voltage of HPD test point close to the HDMI output terminal [N1030] indicate Hi (3-5 V)?

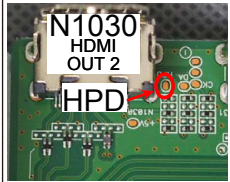

YES NO

Check for a short circuit in the HPD line.
If there is no problem, the HDMI Tx [U1039] is faulty.
Replace with a new device.

HDMI Tx [U1039] is faulty.
Replace with a new device.

Recheck from check item (3).
If it does not work, replace the PCB.

When the results of check item (65) are "00"
(Detection of HPD is not OK / Detection of RXSENSE is not OK)

Checking the HPD/RXSENSE status register. (Monitor2)

Check item(71). Checking the HPD and RXSENSE. :
Does the test point of RXSENSE close to the HDMI output terminal [N1030] indicate the (3.3V)?
Does the voltage of HPD test point close to the HDMI output terminal [N1030] indicate "Hi" (3-5 V)?

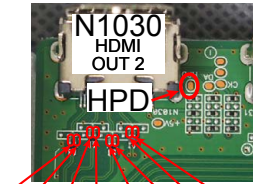

D2+ D2- D1+ D1- D0+ D0- CK+ CK-

YES NO

Check for a short circuit in the TMDS/ HPD line.
If there is no problem, the HDMI Tx [U1039] is faulty.
Replace with a new device.

HDMI Tx [U1039] is faulty.
Replace with a new device.

Recheck from check item (3).
If it does not work, replace the PCB.

3-13. GUI IC [ADV8003] failure detection procedure

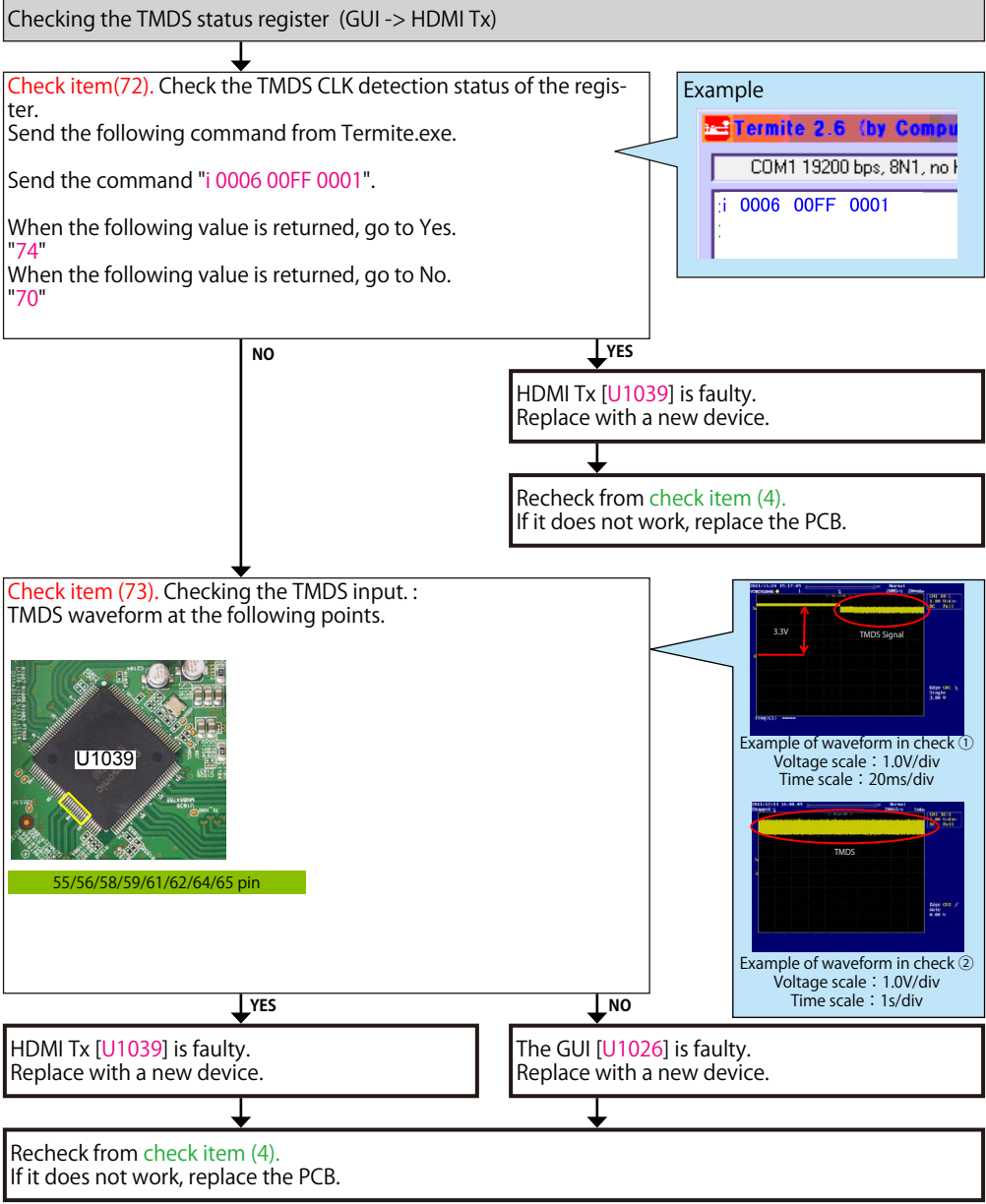

Caution in servicing

Electrical

Mechanical

Repair Information

Updating

3-14. HDMI SW IC [TMDS261B] failure detection procedure

Checking the TMDS status register (HDMI SW -> GUI)

Check item(74). Check the TMDS CLK detection status of the register.
 Send the following command from Termit.exe.
 Send the command "i 00E2 0004 0001".
 When the following value is returned, go to Yes.
 "02"
 When the following value is returned, go to No.
 "other"

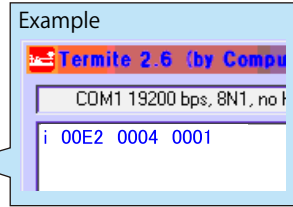

YES
 The GUI [U1026] is faulty.
 Replace with a new device.

Recheck from **check item (5)**.
 If it does not work, replace the PCB.

Check item (75). Checking the TMDS input :
 Check the TMDS waveform at the following test point.
 Is the waveform like the sample?

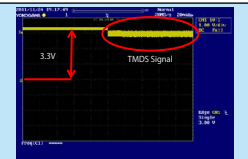
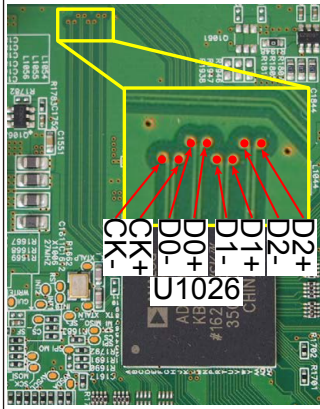

Example of waveform in check ①
 Voltage scale : 1.0V/div
 Time scale : 20ms/div

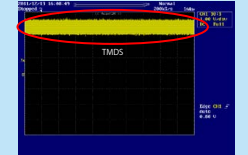

Example of waveform in check ②
 Voltage scale : 1.0V/div
 Time scale : 1s/div

YES
 The GUI [U1026] is faulty.
 Replace with a new device.

NO
 HDMI SW[U1103] is faulty.
 Replace with a new device.

Recheck from **check item (5)**.
 If it does not work, replace the PCB.

4. Device implementation location

DIGITAL (A SIDE)

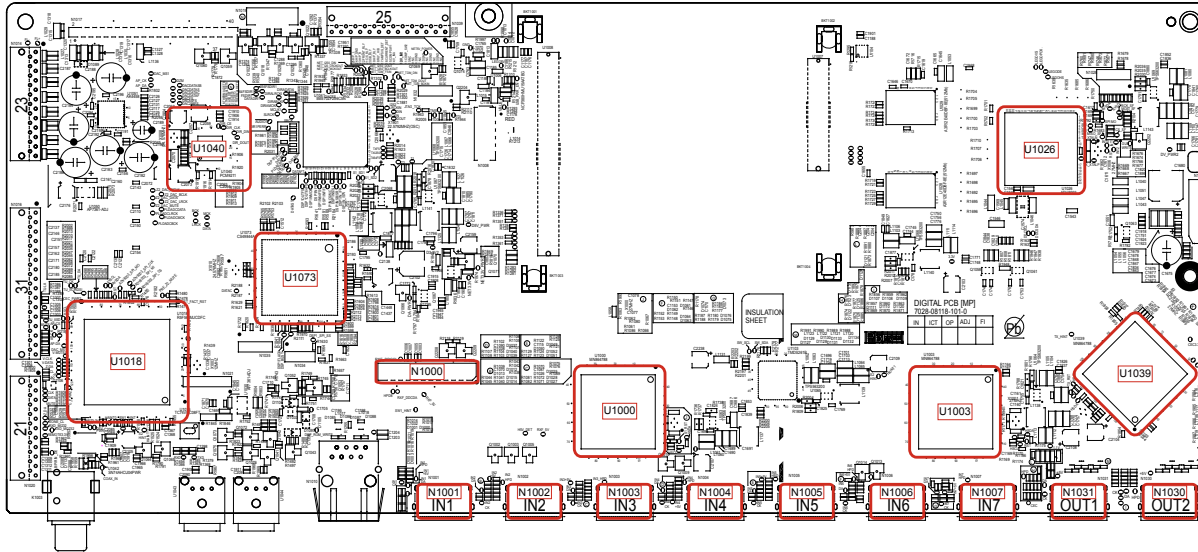

F-HDMI (A SIDE)

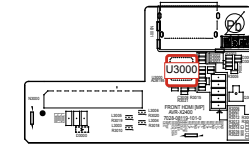

DIGITAL (B SIDE)

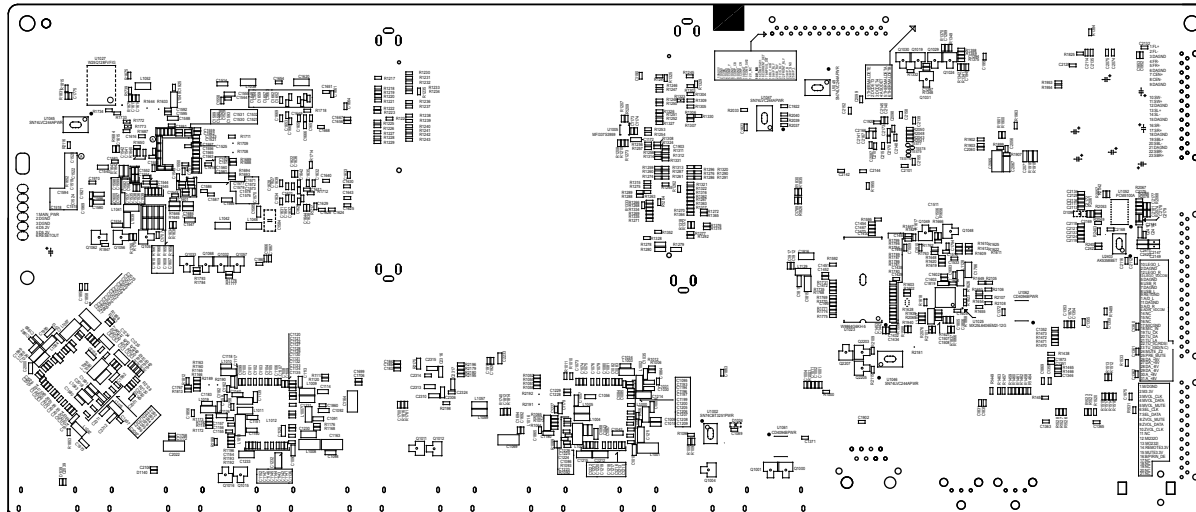

Caution in servicing

Electrical

Mechanical

Repair Information

Updating

CLOCK FLOW & WAVE FORM IN DIGITAL BLOCK

WAVE FORM

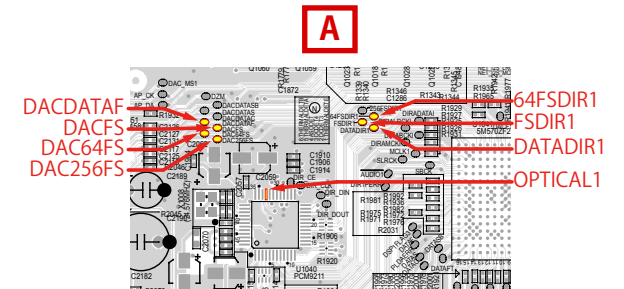
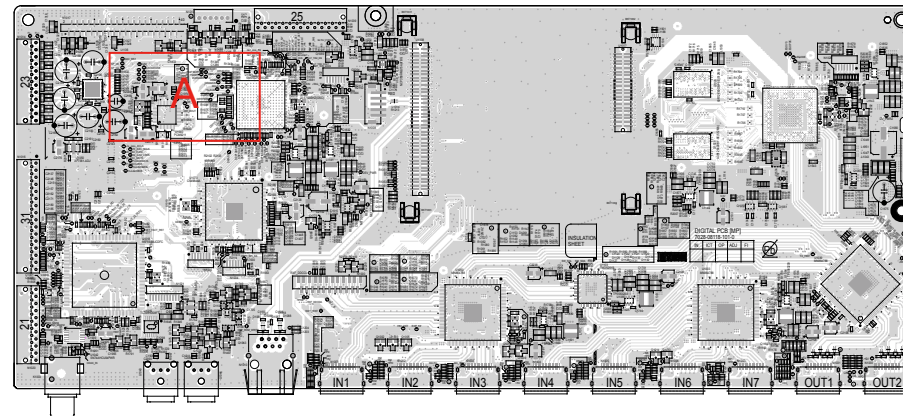
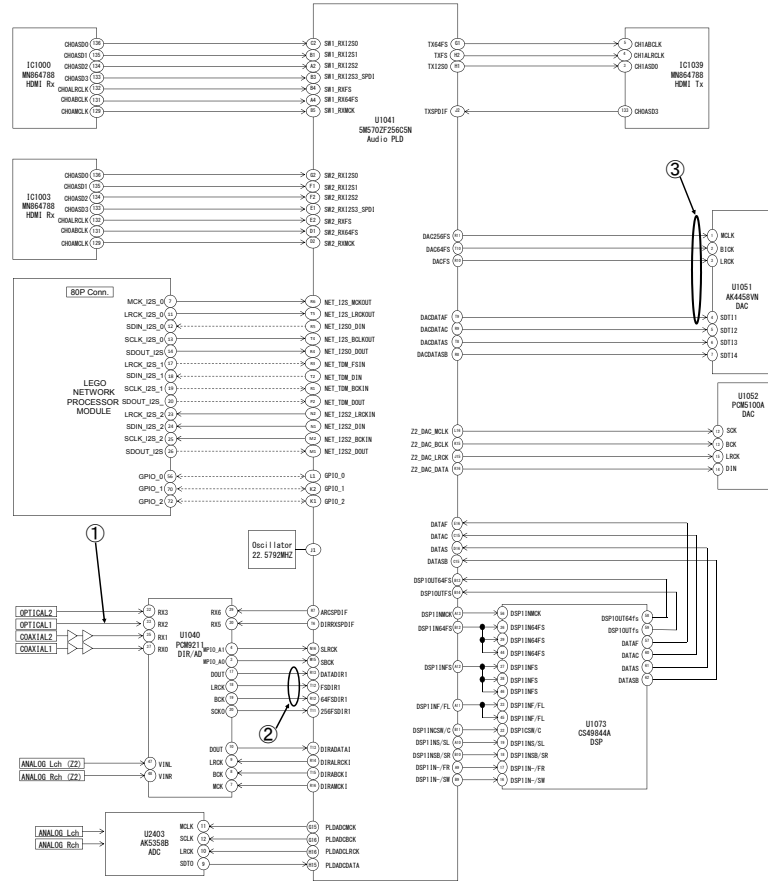
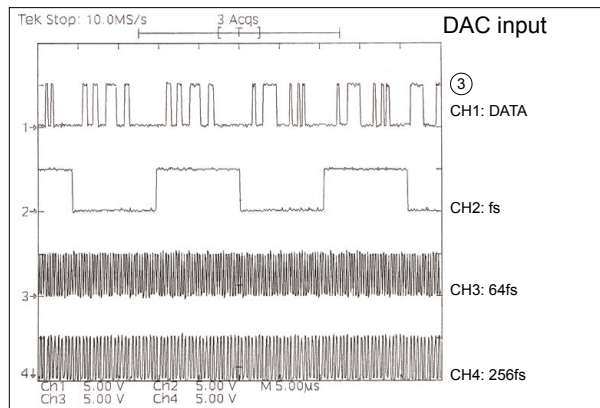
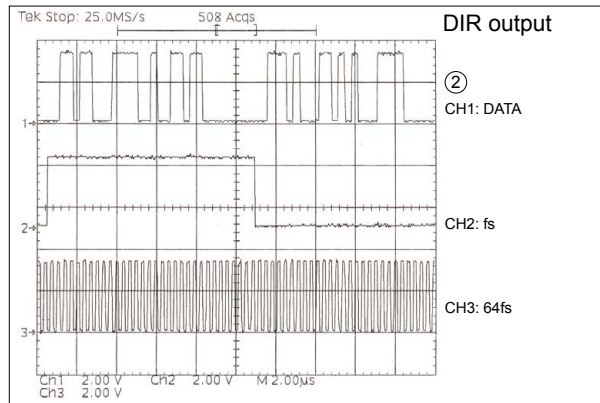
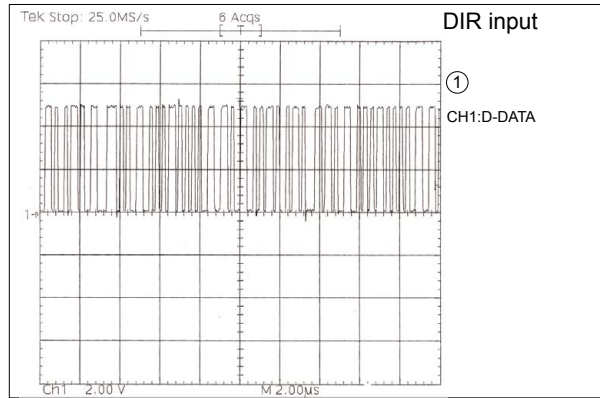

Caution in servicing

Electrical

Mechanical

Repair Information

Updating

SPECIAL MODE

Special mode setting button **AVR-X2400H**

※ No. 1 - 4, 6 - 8: While holding down buttons "A", "B" and "C" simultaneously, press the power button to turn on the power.

※ No. 5, 9: While the power is on, hold down buttons "A" and "B" for at least 3 seconds.

No.	Mode	Button A	Button B	Button C	Descriptions
1	Version Display (u-COM / DSP Error Display)	DIMMER	STATUS	-	Displays the version of firmware such as the main firmware or DSP. Errors that have occurred are displayed. (See 1. Version Display Mode)
2	PANEL / REMOTE LOCK Selection Mode	TUNER PRESET CH +	ZONE2 SOURCE	-	Start this unit in the PANEL/REMOTE LOCK selection mode so that PANEL LOCK and Remote Lock can be switched between On and Off. (See 2. PANEL / REMOTE LOCK Selection Mode) ·PANEL LOCK Mode (with Volume) Disables reception from all keys and encoders on the front panel except the power button (including the volume). ·PANEL LOCK Mode (without Volume) Disables reception from all keys and encoders on the front panel except the power button and volume encoder. ·PANEL LOCK mode is turned off Releases the PANEL LOCK.
3	Selecting the Mode for Service-related	ZONE2 SOURCE	DIMMER	STATUS	This is a display for turning on each service-related mode. Service-related modes:No. 3-1 - No. 3-5
3-1	Check the Video/Audio path Mode	↑	↑	↑	This is a special mode for service confirmation used during repair work to simplify the confirmation work for the Audio channel / video channel. (See Service Path Check Mode)
3-2	Protection history display mode	↑	↑	↑	Displays the protection occurrence history. (See 3-2. Protection History Display Mode)
3-3	232C Standby Clear Mode (E3 model only)	↑	↑	↑	Switches from 232C standby mode to normal standby mode. (See 3-3. 232C Standby Clear Mode (AVR-X2400H E3 only))
3-4	Operation Info Mode	↑	↑	↑	Displays the accumulated operating time of the unit, the number of times the power was switched on, and the number of occurrences of each protection. (See 3-4. Operation Info Mode)
3-5	TUNER STEP Mode (E3 and E2 model only)	↑	↑	↑	Enables reception STEP of the ANALOG TUNER to be changed. (See 3-5. TUNER STEP mode (E2 / E3 only))
3-6	Remote ID Setup Mode	↑	↑	↑	If there are multiple DENON AV receivers in the same area, this mode prevents other AV receivers from being operated concurrently with this device. (See 3-6. Remote ID Setup Mode)
4	Protection Pass Mode	TUNER PRESET CH +	ZONE2 SOURCE	STATUS	Enables the power to be turned on when protection detection is disabled. (See 4. Protection Pass Mode)
5	Network Initialization Mode	TUNER PRESET CH +	ZONE2 ON/OFF	-	Network module backup data is initialized. (See 5. Network Initialization Mode)
6	User Initialization Mode	TUNER PRESET CH -	TUNER PRESET CH +	-	Initialize the backup data for the MCU and network module. (Settings for the Installer Setup are not initialized.)
7	Factory Initialization Mode	ZONE2 SOURCE	DIMMER	-	Initialize the backup data only for MCU. (Settings for the Installer Setup are initialized) (Network function settings are not initialized.) (See Initializing This Unit AVR-X2400H)
8	Clearing the Operation Info	ZONE2 SOURCE	STATUS	-	Clear the accumulated operating time of the unit, the number of times the power was switched on, and the number of occurrences of each protection. (See 7. Clearing the Operation Info)
9	HDMI Diagnostics Mode	ZONE2 SOURCE	TUNER PRESET CH -	-	This mode is used to identify and solve the cause when there is a connectivity issue with this unit and an HDMI device. For details on the operating methods and diagnosis procedures, see the HDMI Diagnostics and Troubleshooting guide issued on SDI.

NOTE: When the volume indicator displays " -000 ", the unit has entered a special mode for developers. In this case, the RS-232C communication is not available. To release this special mode, press and hold the "ZONE2 SOURCE" and "TUNER PRESET CH +" buttons for 3 seconds or more while the power is ON. When the volume indicator returns to the normal display, the RS-232C communication is available.

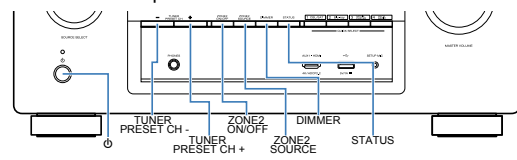

Caution in servicing

Electrical

Mechanical

Repair Information

Updating

Special mode setting button AVR-S930H

※ No. 1 - 4, 6 - 8: While holding down buttons "A", "B" and "C" simultaneously, press the power button to turn on the power.

※ No. 5, 9: While the power is on, hold down buttons "A" and "B" for at least 3 seconds.

No.	Mode	Button A	Button B	Button C	Descriptions
1	Version Display (u-COM / DSP Error Display)	DIMMER	STATUS	-	Displays the version of firmware such as the main firmware or DSP. Errors that have occurred are displayed. (See 1. Version Display Mode)
2	PANEL / REMOTE LOCK Selection Mode	ZONE2 SOURCE	TUNER PRESET CH +	-	Start this unit in the PANEL/REMOTE LOCK selection mode so that PANEL LOCK and Remote Lock can be switched between On and Off. (See 2. PANEL / REMOTE LOCK Selection Mode) ·PANEL LOCK Mode (with Volume) Disables reception from all keys and encoders on the front panel except the power button (including the volume). ·PANEL LOCK Mode (without Volume) Disables reception from all keys and encoders on the front panel except the power button and volume encoder. ·PANEL LOCK mode is turned off Releases the PANEL LOCK.
3	Selecting the Mode for Service-related	TUNER PRESET CH +	TUNE -	TUNE +	This is a display for turning on each service-related mode. Service-related modes:No. 3-1 - No. 3-5
3-1	Check the Video/Audio path Mode	↑	↑	↑	This is a special mode for service confirmation used during repair work to simplify the confirmation work for the Audio channel / video channel. (See Service Path Check Mode)
3-2	Protection history display mode	↑	↑	↑	Displays the protection occurrence history. (See 3-2. Protection History Display Mode)
3-3	Operation Info Mode	↑	↑	↑	Displays the accumulated operating time of the unit, the number of times the power was switched on, and the number of occurrences of each protection. (See 3-4. Operation Info Mode)
3-4	TUNER STEP Mode (E3 and E2 model only)	↑	↑	↑	Enables reception STEP of the ANALOG TUNER to be changed. (See 3-5. TUNER STEP mode (E2 / E3 only))
3-5	Remote ID Setup Mode	↑	↑	↑	If there are multiple DENON AV receivers in the same area, this mode prevents other AV receivers from being operated concurrently with this device. (See 3-6. Remote ID Setup Mode)
4	Protection Pass Mode	ZONE2 SOURCE	TUNER PRESET CH +	TUNE +	Enables the power to be turned on when protection detection is disabled. (See 4. Protection Pass Mode)
5	Network Initialization Mode	ZONE2 SOURCE	ZONE2 ON/OFF	-	Network module backup data is initialized. (See 5. Network Initialization Mode)
6	User Initialization Mode	TUNER PRESET CH -	TUNER PRESET CH +	-	Initialize the backup data for the MCU and network module. (Settings for the Installer Setup are not initialized.)
7	Factory Initialization Mode	TUNER PRESET CH +	TUNE -	-	Initialize the backup data only for MCU. (Settings for the Installer Setup are initialized) (Network function settings are not initialized.) (See Initializing This Unit AVR-S930H)
8	Clearing the Operation Info	TUNER PRESET CH +	TUNE +	-	Clear the accumulated operating time of the unit, the number of times the power was switched on, and the number of occurrences of each protection. (See 7. Clearing the Operation Info)
9	HDMI Diagnostics Mode	ZONE2 SOURCE	TUNER PRESET CH -	-	This mode is used to identify and solve the cause when there is a connectivity issue with this unit and an HDMI device. For details on the operating methods and diagnosis procedures, see the HDMI Diagnostics and Troubleshooting guide issued on SDI.



NOTE: When the volume indicator displays " -000 ", the unit has entered a special mode for developers. In this case, the RS-232C communication is not available.

To release this special mode, press and hold the "ZONE2 SOURCE" and "TUNER PRESET CH +" buttons for 3 seconds or more while the power is ON. When the volume indicator returns to the normal display, the RS-232C communication is available.

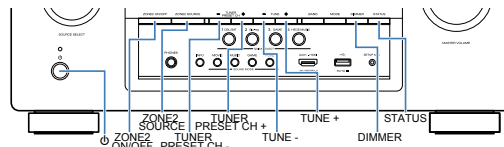

1. Version Display Mode

1.1. Actions

Version information is displayed when the device is started in this mode.

1.2. Starting up

While holding down buttons "DIMMER" and "STATUS" simultaneously, press the power button to turn on the power.

then press the "STATUS" button to display the information in section 1.3 on the display.

※ The version list is also displayed on GUI while the version is displayed on the display.

1.3. Display Order

Error information(See "1.4. Error display") → ① Model destination information → ② Serial Number → ③ Firmware Package → ④ Main μ -com → ⑤ Main 1st Boot Loader → ⑥ DSP → ⑦ Audio PLD → ⑧ GUI SFLASH → ⑨ HEOS Version → ⑩ HEOS Build → ⑪ HEOS Module → ⑫ HEOS Configuration → ⑬ HEOS Locale → ⑭ Ether Mac Address → ⑮ Wi-Fi Mac Address → ⑯ BT Mac Address → ⑰ Audyssey App Interface Version

① Model destination information :

```
AUR-S930H E3 *
AUR-X2400H \ \ *
  \ : Region (E3, E2, E1C, JP)
```

② Serial Number :

```
SN*****
```

③ Firmware Package :

```
Package :****
```

④ Main μ -com :

```
M *****
```

⑤ Main 1st Boot Loader :

```
Main FBL :***.***
```

⑥ DSP ROM :

```
DSP :***.***
```

⑦ Audio PLD :

```
Audio PLD:***.***
```

⑧ GUI SFLASH :

```
GUI :@#$\****
```

@ : Model code, # : Brand code (DENON=1),
 \ : Region code (E3=1, E2=2, E1C=5, JP=4,
 ALL=0), * : version

⑨ HEOS Version :

```
HEOS Version
↓"Press "STATUS" button.
```

```
*.***.***
```

⑩ HEOS Build :

```
HEOS Build
↓"Press "STATUS" button.
*****
```

⑪ HEOS Module :

```
HEOS Module
↓"Press "STATUS" button.
***
```

⑫ HEOS Config :

```
HEOS Config
↓"Press "STATUS" button.
Production
```

⑬ HEOS Locale :

```
HEOS Locale
↓"Press "STATUS" button.
*****
```

⑭ Ether MAC Address :

```
*Ether MAC
↓"Press "STATUS" button.
*****-*****
```

⑮ Wi-Fi MAC Address :

```
*Wi-Fi MAC
↓"Press "STATUS" button.
*****-*****
```

⑯ Bluetooth MAC Address :

```
*BT MAC Address
↓"Press "STATUS" button.
*****-*****
```

⑰ Audyssey App Interface Ver :

```
Audy IFVer:***.***
```

1.4. Error display

See the table below for descriptions of the displayed errors and countermeasures for these.

If multiple errors occur, only one item is displayed.

The priority order is ②, ③, ④, ⑤, ⑥, ①.

Condition	States	Display	TROUBLE SHOOTING
① Firm Check NG	The model name, brand name and region information written in the firmware are compared to the region settings in the PCB. This error is displayed if the information does not match. "▲" is displayed as the first character if the firmware is not correct (see the illustrations on the right).	<div style="border: 1px solid black; padding: 2px; text-align: center;">FIRM ERROR</div> <div style="border: 1px solid black; padding: 2px; text-align: center;">▲MI *****</div> <div style="border: 1px solid black; padding: 2px; text-align: center;">▲Main FBL : **: **</div> <div style="border: 1px solid black; padding: 2px; text-align: center;">▲DSP : **: **</div> <div style="border: 1px solid black; padding: 2px; text-align: center;">▲Audio PLD: **: **</div> <div style="border: 1px solid black; padding: 2px; text-align: center;">▲GUI : *****</div>	<ul style="list-style-type: none"> •Check the resistor for setting the region(R1524 / 1525 DIGITAL PCB). •Write the firmware for the correct region.
② IP SCALER NG	An error occurs in Loop back Test of the DDR memory which is performed during the initial setting of i/p Scaler(ADV8003). During the initial setting of i/p Scaler (ADV8003) , there is not the reply of the Loop back Test result of the DDR memory .	<div style="border: 1px solid black; padding: 2px; text-align: center;">IP SCALER ERR 01</div> <div style="border: 1px solid black; padding: 2px; text-align: center;">IP SCALER ERR 02</div>	<ul style="list-style-type: none"> •Check the circuits around the IP SCALER (U1026, DIGITAL PCB) and DDR2 (U1028/1029). If there appear to be no problems, U1026 or U1028/1029 is faulty.
③ GUI Serial Flash NG	If the Main CPU version is not supported by the GUI Serial Flash (ADV8003), "▼" is displayed as the first character of the GUI firmware version.	<div style="border: 1px solid black; padding: 2px; text-align: center;">▼GUI VER. ERROR</div> <div style="border: 1px solid black; padding: 2px; text-align: center;">▼GUI : *****</div>	<ul style="list-style-type: none"> •Check the firmware version.
④ DIR NG	This error is displayed if there is no response from the DIR.	<div style="border: 1px solid black; padding: 2px; text-align: center;">DIR ERROR 01</div>	<ul style="list-style-type: none"> •Check the DIR (U1040, DIGITAL PCB) and surrounding circuits.
⑤ DSP NG	The DSP FLAG0 port does not enter "Hi" status while booting a DSP code even after resetting DSP. The DSP FLAG0 port does not enter "Hi" status before issuing a DSP command. Setting WRITE to "Lo" does not set ACK to "Hi" during DSP data reading. Setting REQ to "Lo" does not set ACK to "Lo" during DSP data reading. Setting WRITE to "Hi" does not set ACK to "Hi" during DSP data writing. Setting REQ to "Lo" does not set ACK to "Lo" during DSP data writing.	<div style="border: 1px solid black; padding: 2px; text-align: center;">DSP ERROR 01</div> <div style="border: 1px solid black; padding: 2px; text-align: center;">DSP ERROR 02</div> <div style="border: 1px solid black; padding: 2px; text-align: center;">DSP ERROR 03</div> <div style="border: 1px solid black; padding: 2px; text-align: center;">DSP ERROR 04</div> <div style="border: 1px solid black; padding: 2px; text-align: center;">DSP ERROR 05</div> <div style="border: 1px solid black; padding: 2px; text-align: center;">DSP ERROR 06</div>	<ul style="list-style-type: none"> •Check the DSP (U1073, DIGITAL PCB) and surrounding circuits.
⑥ EEPROM NG	An error occurred in a checksum of the EEPROM(*** is a block address number).	<div style="border: 1px solid black; padding: 2px; text-align: center;">BACKUP ERROR</div>	

1.5. Version Display in the Setup Menu

Follow the steps below to display the firmware information.

- (1) Press the "SETUP" button on the remote control.
- (2) Select "General - Information - Firmware".

The version information is displayed as a 16-digit number as shown in the screenshot below.



GUI Image

This 16-digit number comprises a part of the version number of each device and module. Numerics and version numbers correspond as shown below.

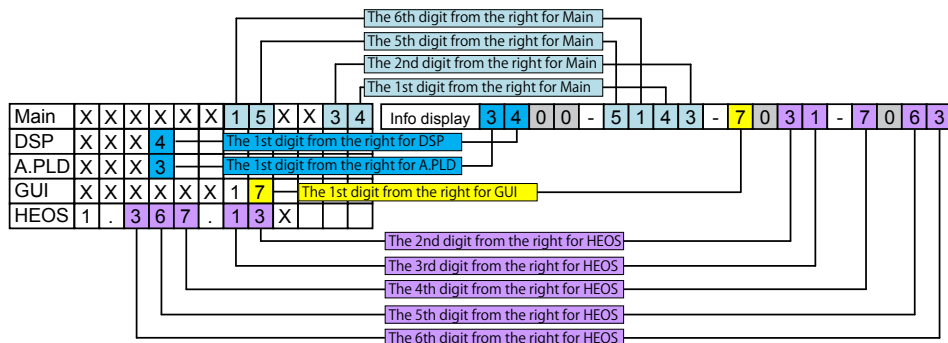

※ The firmware version numbers and this 16-digit version information are written in the Service Information.

※ Replace as follows for the 5th to 7th digits of HEOS version.

- X.XXX.X → X.XXX.00X
- X.XXX.XX → X.XXX.0XX
- X.XXX.XXX → X.XXX.XXX

2. PANEL / REMOTE LOCK Selection Mode

2.1. Actions

Switch the PANEL LOCK and REMOTE LOCK modes between on and off.

2.2. Starting up

While holding down buttons "TUNER PRESET CH+" and "ZONE2 SOURCE" simultaneously, press the power button to turn on the power.

Select the desired mode using the "TUNER PRESET CH+/-" button, then press the "STATUS" button to confirm.

2.3. Displaying and Selecting Each Mode

The information shown on the display switches each time the "TUNER PRESET CH+" button is pressed.

Press the "STATUS" button to set the currently displayed mode and restart the device.

The setting with "*" is selected for each mode.

①

FP/VOL LOCK*On

The buttons on the unit and the master volume knob does not function.



②

FP LOCK On

The buttons on the unit does not function.



③

FP LOCK Off

The PANEL LOCK mode is turned off.



④

RC LOCK On

The device cannot be operated by the remote control.



⑤

RC LOCK *Off

The REMOTE LOCK mode is turned off.

3-1. Selecting the Mode for Service-related

3-1.1. Actions

Select diagnostic mode (service path check mode), protection history display mode, 232C standby clear mode, Operation Info mode, TUNER STEP mode or Remote ID Setup Mode.

3-1.2. Starting up

AVR-X2400H

- While holding down buttons "ZONE2 SOURCE", "DIMMER" and "STATUS" simultaneously, press the power button to turn on the power.

AVR-S930H

- While holding down buttons "TUNER PRESET CH+", "TUNE -" and "TUNE +" simultaneously, press the power button to turn on the power.

Select the desired mode using the "TUNER PRESET CH+/-" button, then press the "STATUS" button to confirm.

3-1.3. Displaying and Selecting Each Mode

The information shown on the display switches each time the "TUNER PRESET CH+" button is pressed.

Press the "STATUS" button to set the currently displayed mode and restart the device.

①

1. SERVICE CHECK

Service Path Check Mode : See "DIAGNOSTIC MODE"

The Video and Audio paths can be checked.

This function is convenient for confirming problem paths in the product and checking the paths after repairing.



②

2. PROTECTION

The protection history can be checked.



③ AVR-X2400H E3 model only

3. RS232C RESET

Switches from 232C standby mode to normal standby mode.



④

4. OP INFO

Operation Info for the unit can be checked.



⑤ E3 and E2 model only

5. TUNER FRQ SET

Enables reception STEP of the ANALOG TUNER to be changed.



⑥

6. REMOTE ID

This function is for operating only the desired AV receiver.

3-1.4. Canceling the selected mode

Press the power button to turn off the power.

3-2. Protection History Display Mode

3-2.1. Actions

This mode enables the unit to record and display the event when the THERMAL, ASO or DC protection is activated.

If protections have been activated multiple times, the latest protection operation is recorded.

3-2.2. Starting up

AVR-X2400H

- While holding down buttons "ZONE2 SOURCE", "DIMMER" and "STATUS" simultaneously, press the power button to turn on the power.

AVR-S930H

- While holding down buttons "TUNER PRESET CH+", "TUNE -" and "TUNE +" simultaneously, press the power button to turn on the power.

Select the "2. PROTECTION" using the "TUNER PRESET CH+/-" button, then press the "STATUS" button then to confirm.

3-2.3. Protection information and displays

- Press the "STATUS" button in Protection History Display Mode.
- The protection history can be checked.

- (a) If no protections has occurred.

NO PROTECT

- (b) ASO (if the last protection is ASO)

PRT:ASO

Cause A short circuit occurred between the speaker terminals, or speakers with an impedance outside the rating were connected.

Note : Short circuits in speaker terminals or speakers can be identified.

If the power is turned on in the abnormal state, protection is activated after around 6 seconds and the power is turned off.

- (c) DC (if the last protection is DC)

PRT:DC

Cause : DC output of the power amplifier is abnormal.

If the power is turned on in the abnormal state, protection is activated after around 6 seconds and the power is turned off.

- (d) THERMAL (if the last protection is THERMAL(A) or THERMAL(B) or THERMAL(E))

PRT:THERMAL A

PRT:THERMAL B

PRT:THERMAL E

Cause : Abnormal heat sink temperature.

If the power is turned on under abnormal conditions, the protection function works immediately and the power is turned off.

- (e) Case of CURRENT (when the last protection incident is CURRENT protection)

:CURRENT

Cause : An over current flowed in power amp.

If the power is turned on in the abnormal state, protection is activated after around 90 seconds and the power is turned off.

Caution : These protections may also be activated due to other factors such as disconnection of connectors or operations around the microcomputer.

After viewing the above protection history, press the "STATUS" button to return to the normal display.

3-2.4. Clearing the Protection History

There are two ways to clear the protection history.

- (a) Activate Protection History Display Mode. Press the "**STATUS**" button to display the protection history. Press and hold the "**DIMMER**" button for 3 seconds.

PRT:DC

Press and hold the "**DIMMER**" button for 3 seconds.

PRT: CLEAR

The above message is displayed and the protection history is cleared.

NO PROTECT

- (b) Initialize this unit. (See "**CAUTION IN SERVICING.**")

※ Use the method in **3-2.4. (a)** if you do not want to erase your settings from this unit.

Warning Displays by POWER LED

If the power is turned Off while a protection is being detected, the POWER LED flashes in red to warn you depending on the protection status as follows.

- (a) ASO/DC protection: Flashes at 0.5-second intervals (0.25 seconds lit, 0.25 seconds unlit)
- (b) THERMAL (A/B) protection: Flashes at 2-second intervals (1 seconds lit, 1 seconds unlit)
- (c) CURRENT protection: Flashes at 4-second intervals (2 seconds lit, 2 seconds unlit)

3-3. 232C Standby Clear Mode (AVR-X2400H E3 only)

3-3.1. Actions

Switches from 232C standby mode to normal standby mode.

3-3.2. Starting up

- While holding down buttons "**ZONE2 SOURCE**", "**DIMMER**" and "**STATUS**" simultaneously, press the power button to turn on the power. Select the "**3.RS232C RESET**" using the "**TUNER PRESET CH+/-**" button, then press the "**STATUS**" button then to confirm.

3.RS232C RESET

3-4. Operation Info Mode

3-4.1. Actions

This mode enables the unit to display the accumulated operating time, power On count and each protection count.

3-4.2. Starting up

AVR-X2400H

- While holding down buttons "ZONE2 SOURCE", "DIMMER" and "STATUS" simultaneously, press the power button to turn on the power.

AVR-S930H

- While holding down buttons "TUNER PRESET CH+", "TUNE -" and "TUNE +" simultaneously, press the power button to turn on the power.

Select the "4. OP INFO" using the "TUNER PRESET CH+/-" button, then press the "STATUS" button then to confirm.

3-4.3. Operations

Press the "STATUS" button after starting up this device in Operation Info mode. The following information is displayed in the following order.

- (a) Accumulated operating time

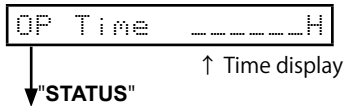

- (b) Power On count

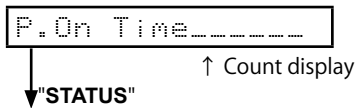

- (c) DC / ASO Protection count



- (d) Thermal Protection (A/B) count



- (e) Thermal Protection (E) count

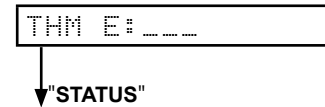

- (f) Current Protection count

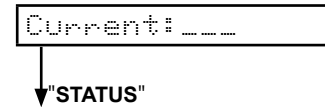

(Returns to normal display)

3-5. TUNER STEP mode (E2 / E3 only)

3-5.1. Actions

This is a special mode for enabling reception STEP of the ANALOG TUNER to be changed.

3-5.2. Starting up

AVR-X2400H

- While holding down buttons "ZONE2 SOURCE", "DIMMER" and "STATUS" simultaneously, press the power button to turn on the power.

AVR-S930H

- While holding down buttons "TUNER PRESET CH+", "TUNE -" and "TUNE +" simultaneously, press the power button to turn on the power.

Select the "5. TUNER FRQ SET" using the "TUNER PRESET CH+/-" button, then press the "STATUS" button then to confirm.

3-5.3. Displays

Start up this unit in TUNER STEP mode, select the desired option using the "TUNER PRESET CH+/-" button, then enter using the "STATUS" button. The following information is displayed in the following order.

- (a) AM9 kHz / FM50 kHz is selected

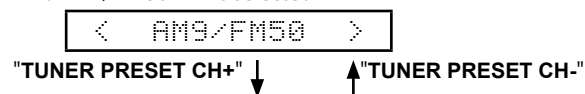

- (b) AM10 kHz / FM200 kHz is selected

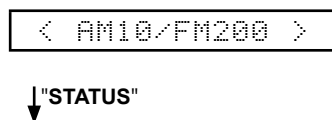

- (c) Press the power button to turn off the power.
(d) Press the power button to turn on the power.

3-6. Remote ID Setup Mode

3-6.1. Actions

This function allows only the desired AV receiver to be operated if multiple DENON AV receivers are used in the same room.

3-6.2. Starting up

AVR-X2400H

- While holding down buttons "ZONE2 SOURCE", "DIMMER" and "STATUS" simultaneously, press the power button to turn on the power.

AVR-S930H

- While holding down buttons "TUNER PRESET CH+", "TUNE -" and "TUNE +" simultaneously, press the power button to turn on the power.

Select the "6. REMOTE ID" using the "TUNER PRESET CH+/-" button, then press the "STATUS" button then to confirm.

3-6.3. Operations

- (a) When Remote ID Setup mode is activated, the following message is displayed.

A rectangular display box containing the text "REMOTE ID ?".

- (b) Press the desired "QUICK SELECT 1 - 4" button.

Button	Display
QUICK SELECT 1	REMOTE ID 1
QUICK SELECT 2	REMOTE ID 2
QUICK SELECT 3	REMOTE ID 3
QUICK SELECT 4	REMOTE ID 4

- (c) Press the power button to turn off the power.
(d) Press the power button to turn on the power.

- ※ Only "QUICK SELECT 1 - 4" and the POWER button on the unit can be used in Remote ID Setup Mode.
- ※ The remote ID of the remote control supplied with this unit cannot be changed.

NOTE :

If the ID of the unit and remote control do not match, "AVAMP*" appears on the display of the unit when the remote control is used
(* : own remote control ID).

4. Protection Pass Mode

4.1. Actions

- This mode allows the power to be turned on without activating protections.
- This mode functions in the same way as normal power-on, except that protections are not activated.
- When using the protection pass mode, do not connect speakers to the speaker terminals.

4.2. Operations

AVR-X2400H

- While holding down buttons "**TUNER PRESET CH +**", "**ZONE2 SOURCE**" and "**STATUS**" simultaneously, press the power button to turn on the power.

AVR-S930H

- While holding down buttons "**ZONE2 SOURCE**", "**TUNER PRESET CH +**" and "**TUNE +**" simultaneously, press the power button to turn on the power.

The device returns to the normal display message after the following is displayed.



This is displayed for 5 seconds before returning to the normal display.

5. Network Initialization Mode

5.1. Actions

The following items are initialized.

- (1) Network setup
- (2) Friendly Name
- (3) Auto Update setting
- (4) Allow Update setting
- (5) Time Zone setting
- (6) Queue list
- (7) Internet Radio recently played station
- (8) Quick Select playback station
- (9) AirPlay Password
- (10) Bluetooth Pairing History

5.2. Operations

AVR-X2400H

- When the power is on and the input source is HEOS Music, press and hold the "**TUNERPRESET CH +**" and "**ZONE2ON/OFF**" buttons for more than 3 seconds.

AVR-S930H

- When the power is on and the input source is HEOS Music, press and hold the "**ZONE2 SOURCE**" and "**ZONE2ON/OFF**" buttons for more than 3 seconds.

Initializing Display



Complete Display



This is displayed for 5 seconds before returning to the normal display.

7. Clearing the Operation Info

7.1. Actions

- Displays the accumulated operating time of the unit, the number of times the power was switched on, and the number of occurrences of each protection.

7.2. Operations

Remove all input/output terminals and the AC plug.

Connect the AC plug again and place the product in standby mode.

AVR-X2400H

- While holding down buttons "**ZONE2 SOURCE**" and "**STATUS**" simultaneously, press the power button to turn on the power.

AVR-S930H

- While holding down buttons "**TUNER PRESET CH +**" and "**TUNE +**" simultaneously, press the power button to turn on the power.

PRODUCT MODE

When "**PRODUCT MODE**" appears on the display, release the button and press the button "**power**" → "**ZONE2 ON/OFF**" to place the product in standby mode.

Service Path Check Mode

1.1. Actions

This function is convenient for confirming problem paths in the product and checking the paths after repairing.
The Video and Audio paths can be checked.
The backup data is not rewritten.

1.2. Starting up

AVR-X2400H

· While holding down buttons "ZONE2 SOURCE", "DIMMER" and "STATUS" simultaneously, press the power button to turn on the power.

AVR-S930H

· While holding down buttons "TUNER PRESET CH+", "TUNE -" and "TUNE +" simultaneously, press the power button to turn on the power.

Select the "1. SERVICE CHECK" using the "TUNER PRESET CH+" button, then press the "STATUS" button then to confirm.
The "TUNED", "STEREO" and "RDS" segments are lit in this mode.

1.3. Canceling diagnostic mode

Press the power button to turn off the power.

1.4. Selecting items to check

Press the ① button to switch between video items and audio items.
Press the ② or ③ button to select the previous or next item.

Actions	The unit			Remote control unit		
	①	②	③	①	②	③
	Audio ⇄ Video	PREVIOUS	NEXT	Audio ⇄ Video	PREVIOUS	NEXT
Button	DIMMER	QUICK SELECT 1	QUICK SELECT 2	SLEEP	CURSOR ◀	CURSOR ▶

1.5. Audio system confirmation items

See the block diagram fig.XXth.

Paths to be confirmed		Display	Settings	What to confirm
1	Analog	fig.01 A01:ANALOG PASS	Input Source : CBL/SAT Input Mode : Analog (fixed) Sound mode : DIRECT Amp assign : Surround Back MAIN ZONE : On ZONE2 : Off	<ul style="list-style-type: none"> Analog input ⇒ Speaker output (Front L/R) (※ The input source can be switched to any source except CBL/SAT.)
2	DIGITAL (MAIN)	fig.02a fig.02b A02: DIGITAL	Input Source : CBL/SAT Input Mode : DIGITAL (fixed) Sound mode : MULTI CH STEREO Amp assign : Surround Back Speaker Config ALL Speaker = Small / SW = Yes(2ch) MAIN ZONE : On ZONE2 : Off	<ul style="list-style-type: none"> Digital input ⇒ Speaker output (Front L/R, Center, Surround L/R, Surround Back L/R) Digital input ⇒ Pre OUT output (Subwoofer) (※ The input source can be switched to any source except CBL/SAT.)
3	DIGITAL (ZONE2)	fig.03a fig.03b A03: DIGITAL-Z2	Input Source : HEOS Music Input Mode : Auto Sound mode : STEREO Amp assign : ZONE2 MAIN ZONE : On ZONE2 : On	<ul style="list-style-type: none"> Digital(PCM) input ⇒ Speaker output (Surround Back (ZONE2) L/R) Digital(PCM) input ⇒ Pre OUT output (ZONE2 L/R) (Except S730/S930)

Paths to be confirmed			Display	Settings	What to confirm
4	HDMI	fig.04a fig.04b	#05: HDMI	Input Source : CBL/SAT Input Mode : HDMI (fixed) Sound mode : STEREO Amp assign : Surround Back MAIN ZONE : On ZONE2 : Off	<ul style="list-style-type: none"> HDMI input ⇒ Speaker output (Front L/R) (※ The input source can be switched to any source except CBL/SAT.)
5	Analog AD (MAIN ZONE)	fig.05a fig.05b	#06: AD	Input Source : CBL/SAT Input Mode : Analog (fixed) Sound mode : MULTI CH STEREO Vol 60(-20dB) Amp assign : Surround Back Speaker Config ALL Speaker = Small/SW = Yes(2ch) MAIN ZONE : On ZONE2 : Off	<ul style="list-style-type: none"> Analog input ⇒ Speaker output (Front L/R, Center, Surround L/R, Surround Back L/R) Analog input ⇒ Pre OUT output SW(20Hz) (※ The input source can be switched to any source except CBL/SAT.) (※ Volume 60 is the value when Absolute settings are used. The value is -20 when Relative settings are used)
6	Analog Amp Assign (Amp Assign : ZONE2)	fig.06	#07: ASSIGN-Z2	Input Source : CBL/SAT Input Mode : Auto Sound mode : STEREO Z2 Source : Source Vol 60(-20dB) Amp assign : ZONE2 MAIN ZONE : On ZONE2 : On	<ul style="list-style-type: none"> Analog input ⇒ Speaker output (Surround Back (ZONE2) L/R) Analog input ⇒ Pre OUT output (ZONE2 L/R) (※ The input source can be switched to any source except CBL/SAT.) (※ Volume 60 is the value when Absolute settings are used. The value is -20 when Relative settings are used)

1.6. Confirmation items for the video system

See the block diagram fig.XXth.

Paths to be confirmed			Display	Settings	What to confirm
1	Analog Video pass	fig.07	U01: VIDEO PASS	Input Source : CBL/SAT MAIN ZONE : On ZONE2 : On	<ul style="list-style-type: none"> CVBS input ⇒ CVBS output Component input ⇒ Component output (S930 / X2400E3 ONLY) (※ The input source can be switched to any source except CBL/SAT.)
2	Video Convert (HDMI ⇒ HDMI)	fig.08	U02: V. CONVERT	Input Source : CBL/SAT Video Mode (IP Scaler) : "Auto", All sources IP Scaler : "HDMI", All sources Resolution : "Auto", All sources MAIN ZONE : On ZONE2 : Off	<ul style="list-style-type: none"> HDMI input ⇒ IP Scaler ⇒ HDMI output. ETHERNET input ⇒ IP Scaler ⇒ HDMI output. (※ The input source can be switched to any source except CBL/SAT.)
3	HDMI pass (MAIN ZONE)	fig.09	U03: HDMI PASS	Input Source : CBL/SAT Video Mode (IP Scaler) : Bypass (S930 / X2400 ONLY) MAIN ZONE : On ZONE2 : Off	<ul style="list-style-type: none"> HDMI input (MAIN function) ⇒ HDMI output (MAIN) (※ The input source can be switched to any source except CBL/SAT.)
4	HDMI CEC (Control Monitor : HDMI Monitor1)	fig.10	U04: HDMI CEC	Input Source : CBL/SAT HDMI Control : On MAIN ZONE : On ZONE2 : Off	<ul style="list-style-type: none"> When the power supply of a TV is put in the standby mode, make sure that the power supply of this unit is also put in the standby mode. (※ The input source can be switched to any source except CBL/SAT.) The ARC path can also be checked (check this using the TV input source).

Paths to be confirmed		Display	Settings	What to confirm
5	HDMI Audio (Audio : AVR)	fig.11a fig.11b	U05:H.AUDIO-AVR Input Source : CBL/SAT HDMI Control : Off HDMI Audio : AVR (if checking the audio output from AVR)	<ul style="list-style-type: none"> • HDMI input (PCM , DolbyDigital , DTS) ⇒ Speaker output. • HDMI input(HD audio) ⇒ Speaker output. (※ The input source can be switched to any source except CBL/SAT.)
6	HDMI Audio (Audio : TV)	fig.12	U06:H.AUDIO-TV HDMI Audio : TV (if checking the audio output from TV)	<ul style="list-style-type: none"> • HDMI input (PCM , DolbyDigital , DTS) ⇒ HDMI output (audio output from connected TV) (※ The input source can be switched to any source except CBL/SAT.)
7	GUI	fig.13	U07:GUI MENU ON Input Source : CBL/SAT IP Scaler : On, All sources Resolution : "AUTO", All sources Setup Menu : On MAIN ZONE : On ZONE2 : Off	<ul style="list-style-type: none"> • GUI display ⇒ HDMI output. (※ The input source can be switched to any source except CBL/SAT.)

DIAGNOSTIC PATH DIAGRAM

fig.01

AVR_S930H / X2400H / ANALOG AUDIO DIAGRAM

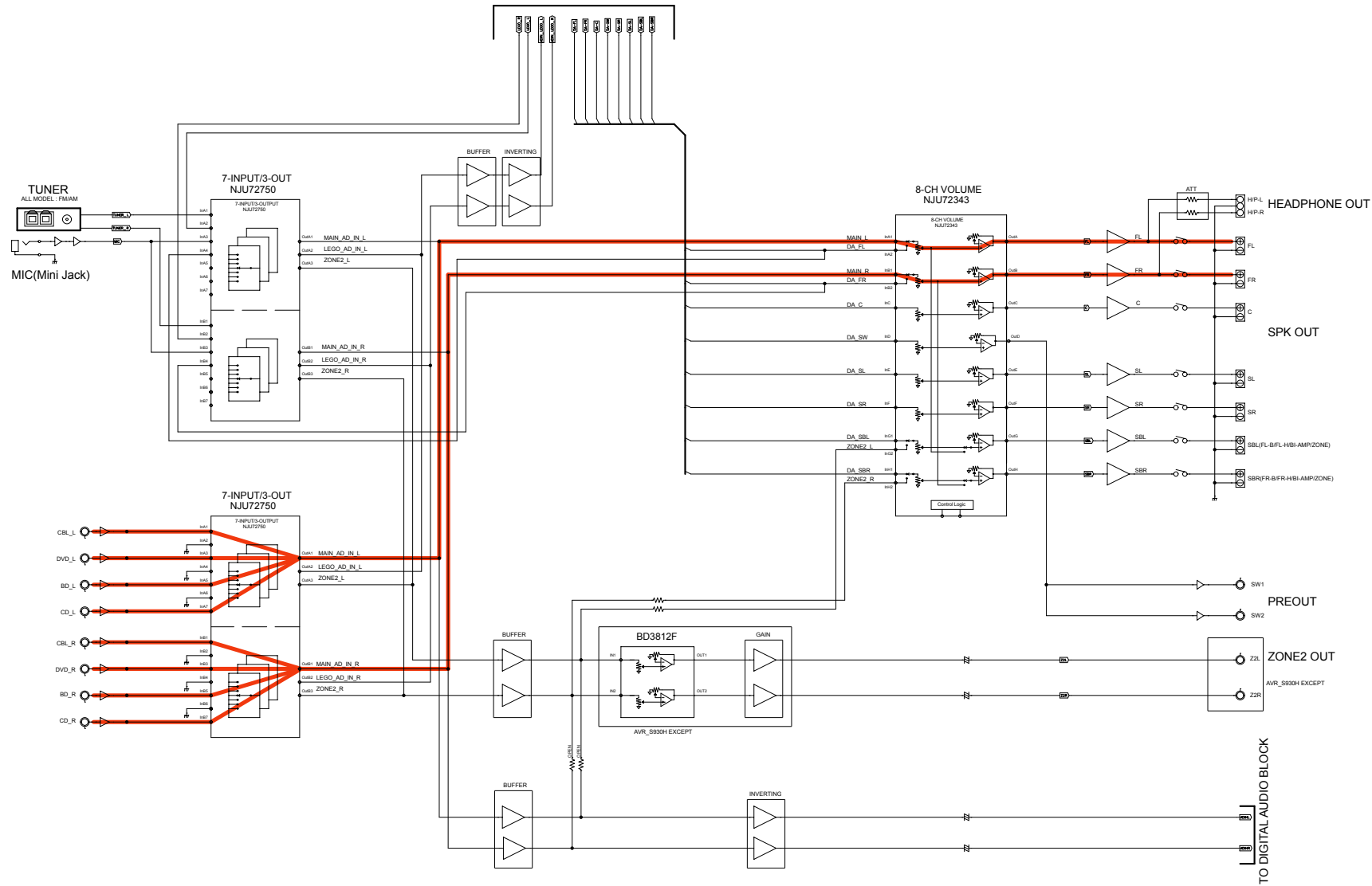

Caution in servicing

Electrical

Mechanical

Repair Information

Updating

fig.02a

AVR_S930H / X2400H DIGITAL AUDIO DIAGRAM

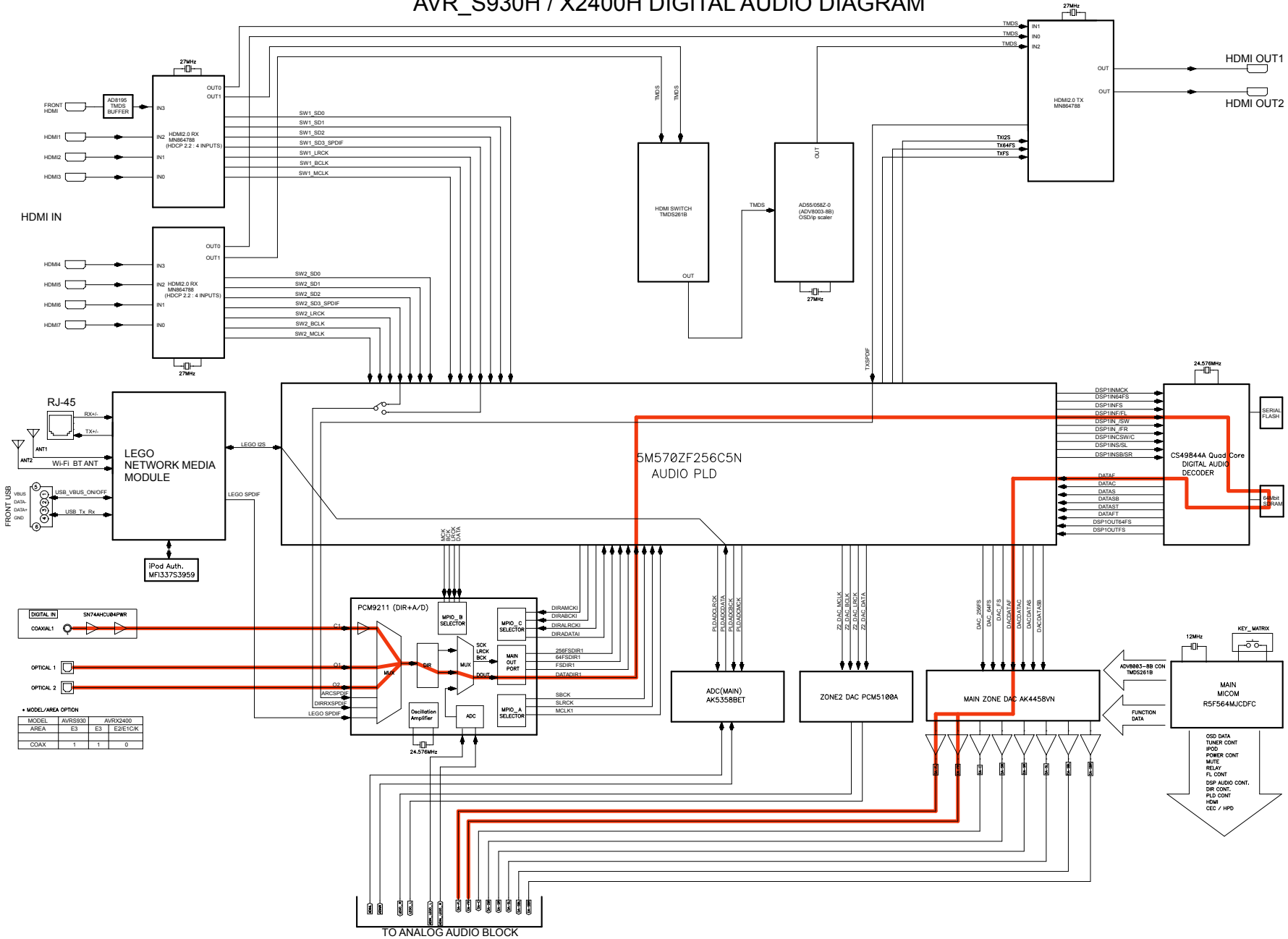

fig.02b

AVR_S930H / X2400H / ANALOG AUDIO DIAGRAM

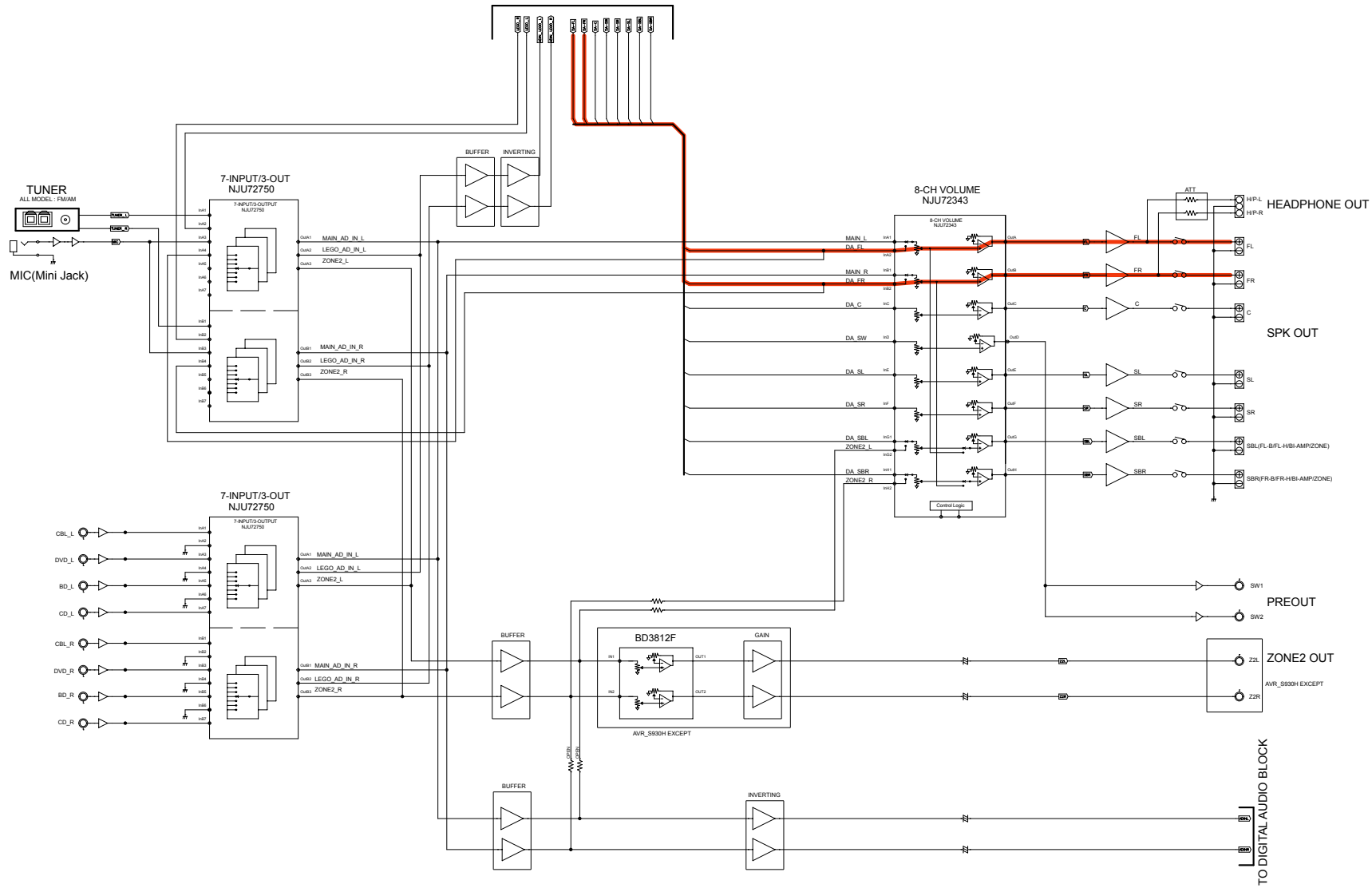

fig.03a

AVR_S930H / X2400H DIGITAL AUDIO DIAGRAM

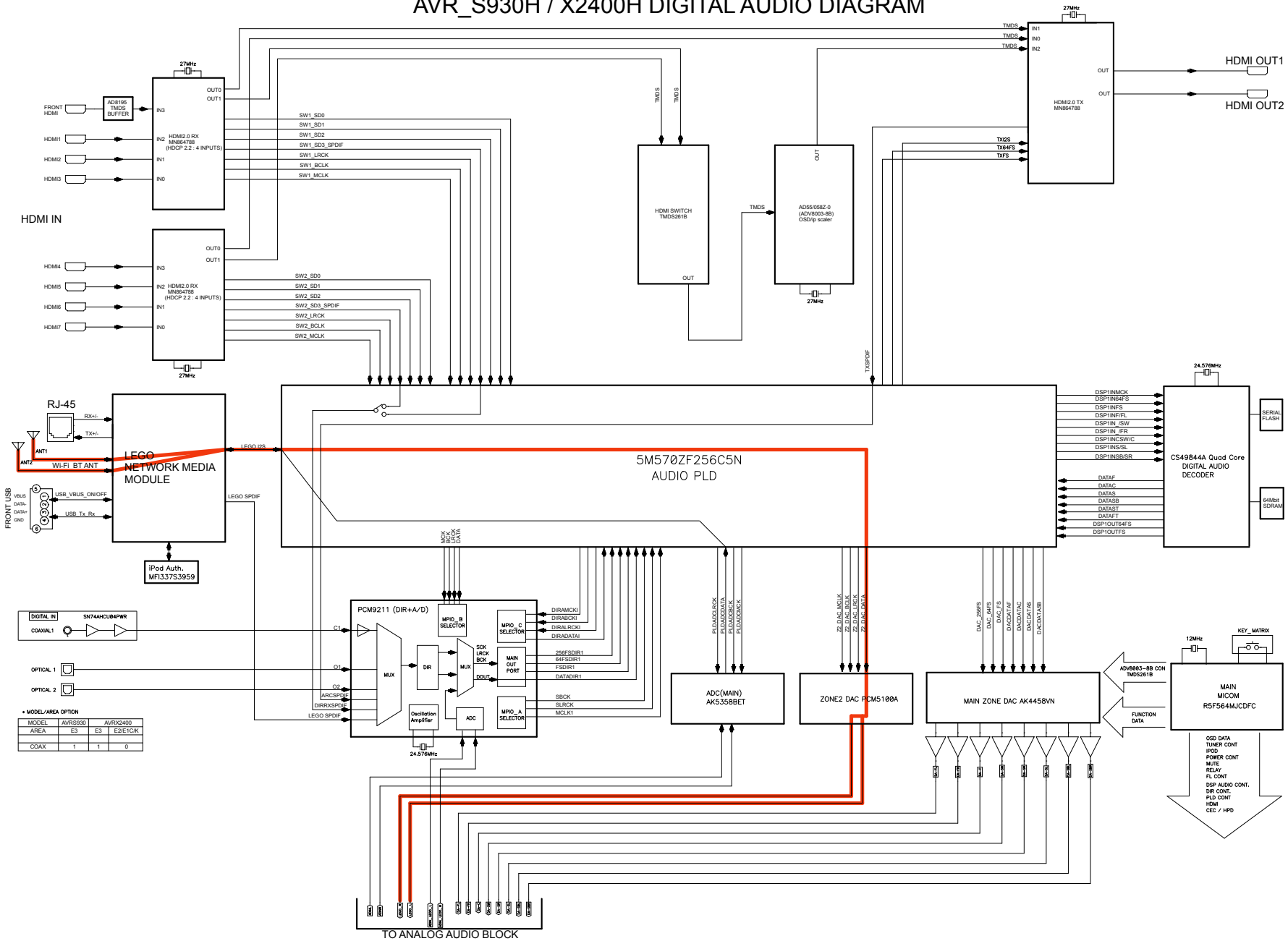

fig.03b

AVR_S930H / X2400H / ANALOG AUDIO DIAGRAM

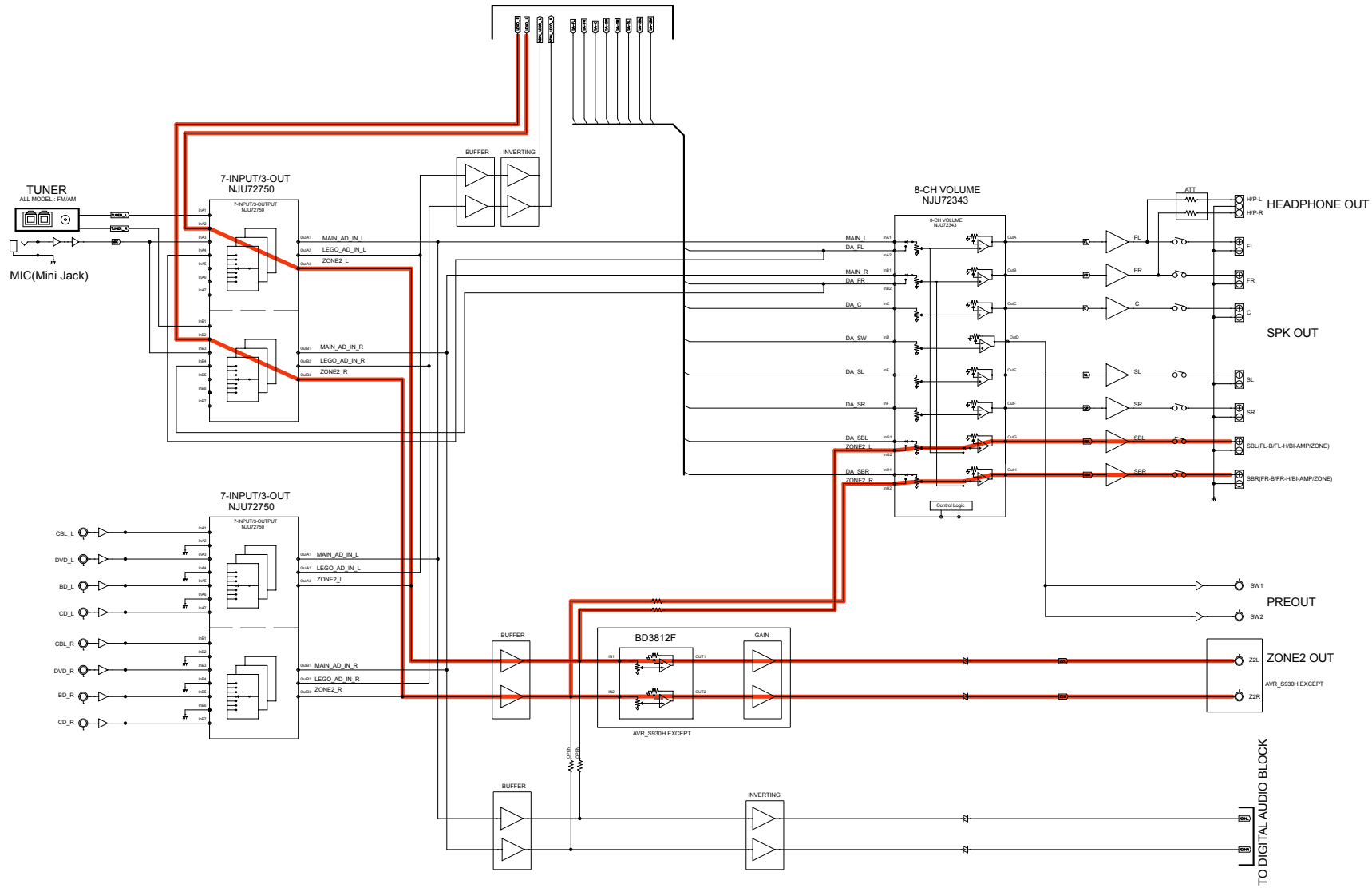

fig.04a

AVR_S930H / X2400H DIGITAL AUDIO DIAGRAM

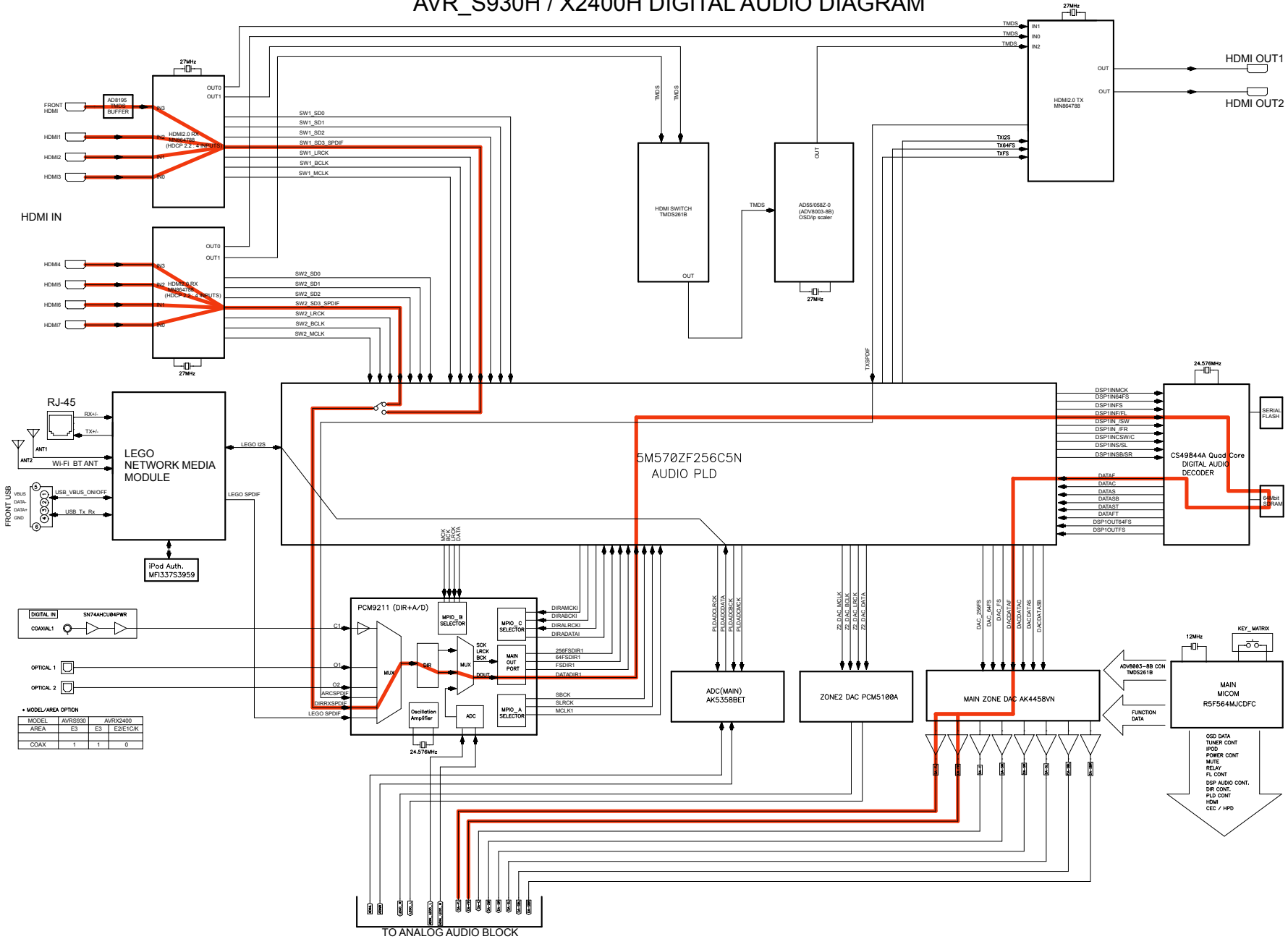

fig.04b

AVR_S930H / X2400H / ANALOG AUDIO DIAGRAM

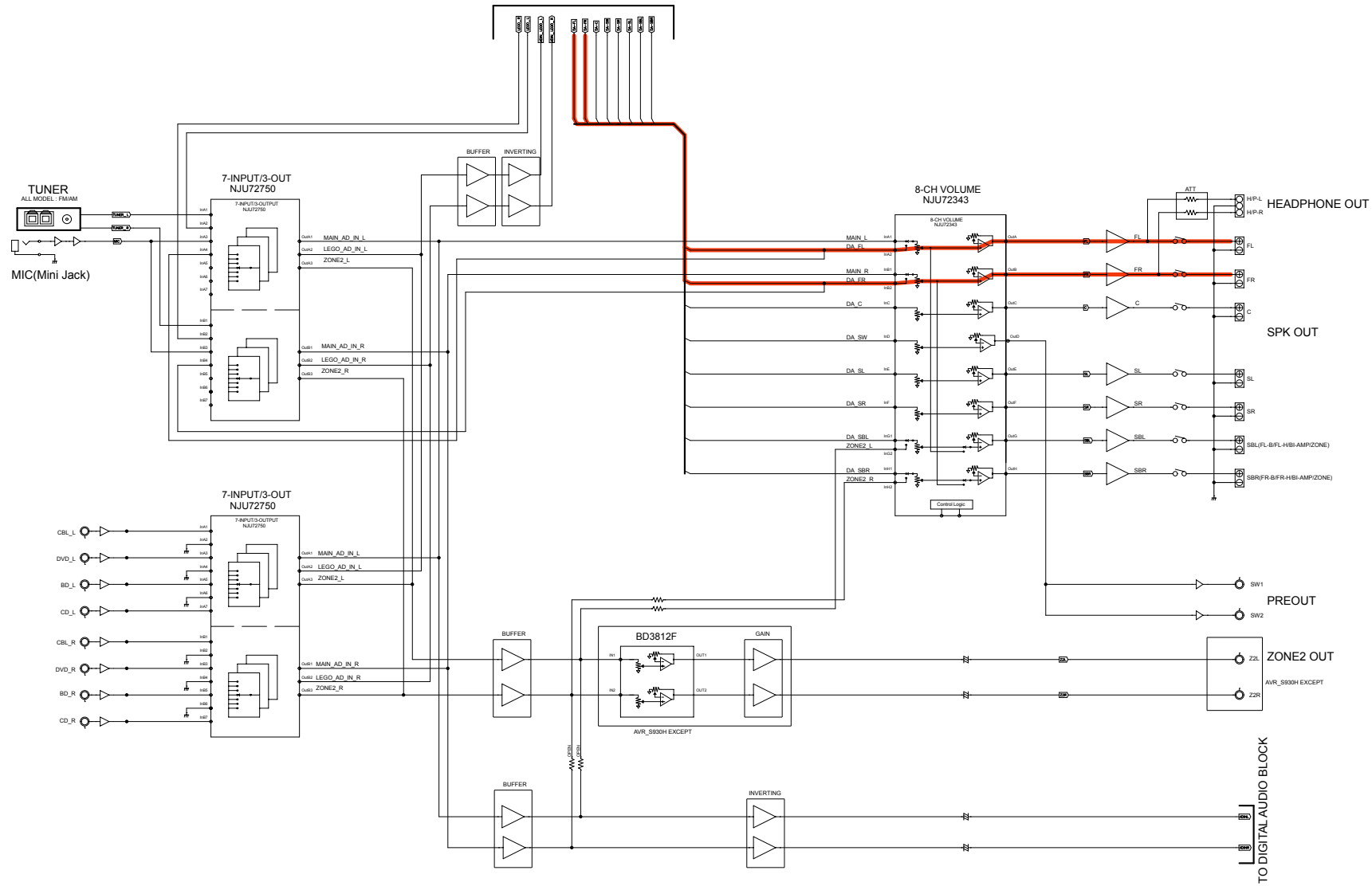

fig.05a

AVR_S930H / X2400H DIGITAL AUDIO DIAGRAM

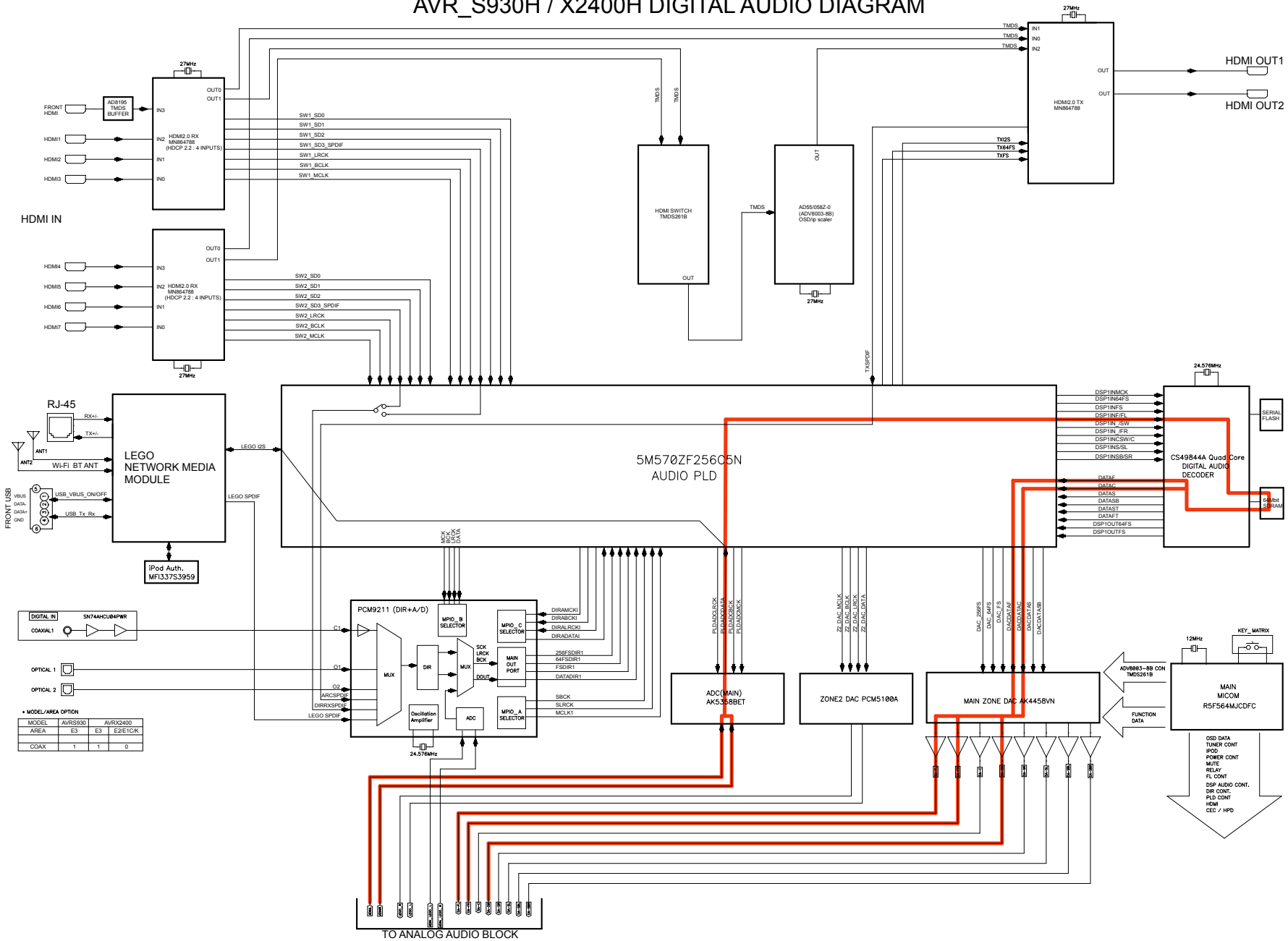

fig.05b

AVR_S930H / X2400H / ANALOG AUDIO DIAGRAM

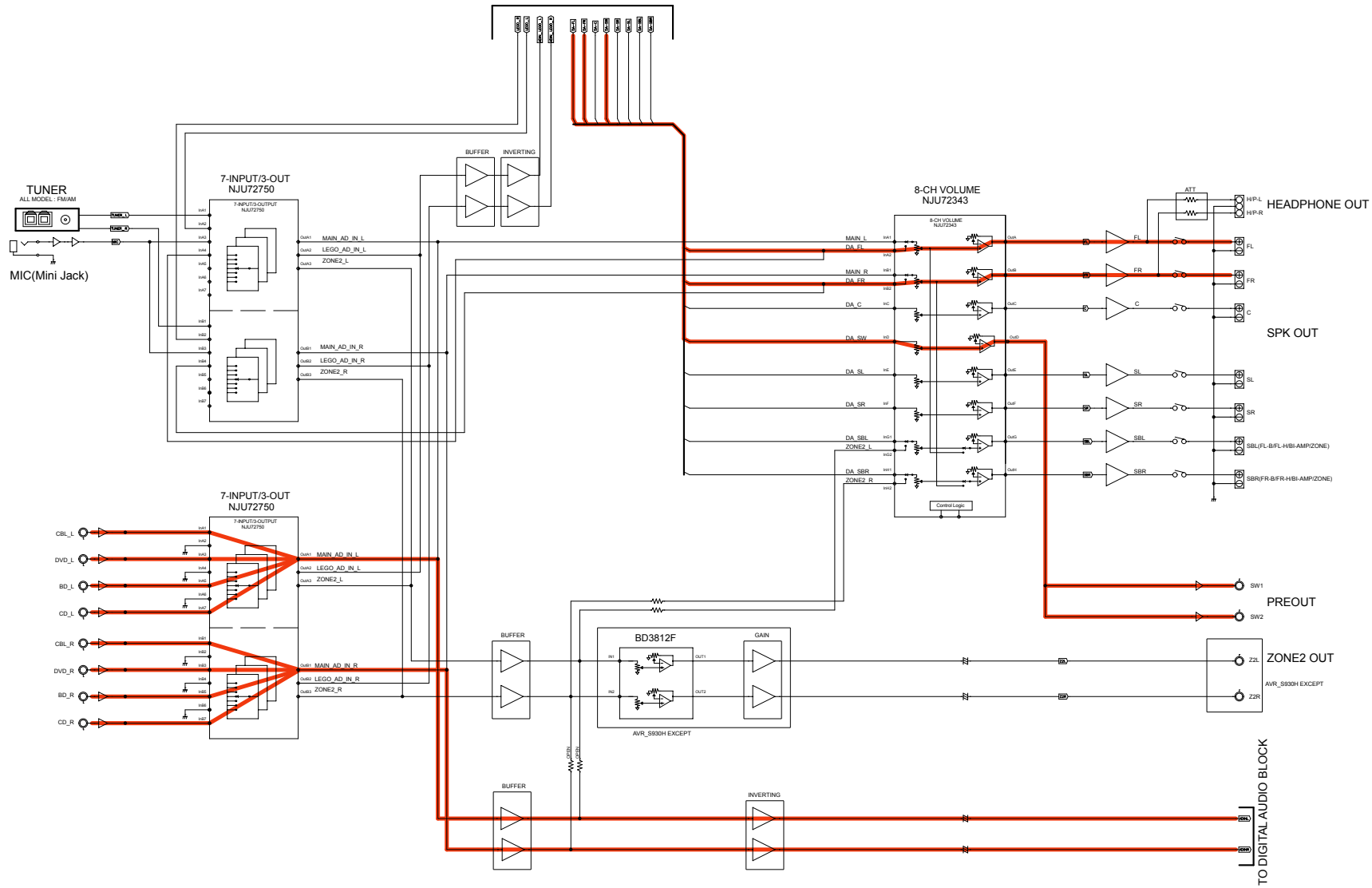

fig.06

AVR_S930H / X2400H / ANALOG AUDIO DIAGRAM

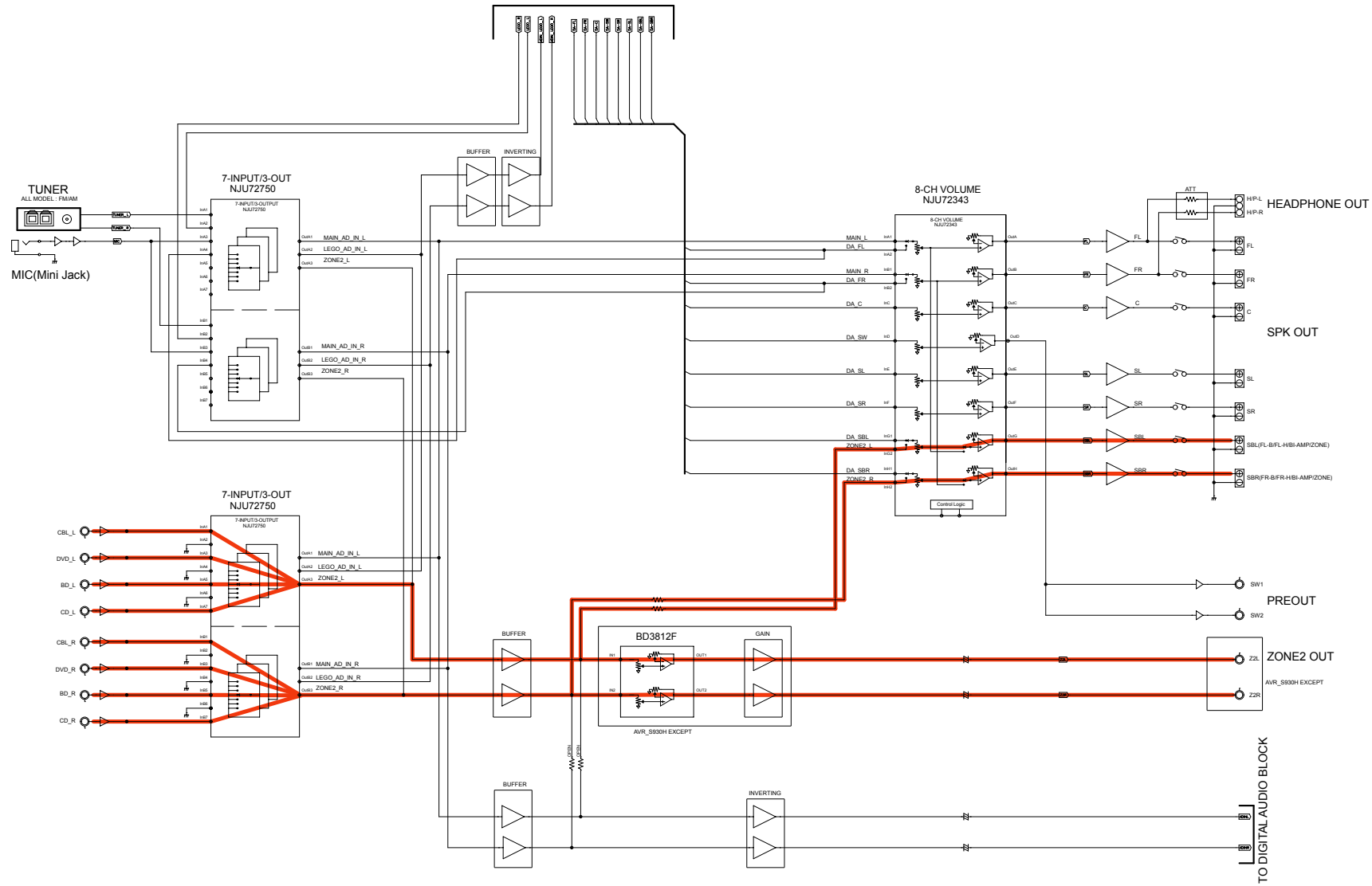

fig.07

AVR_S930H / X2400H VIDEO DIAGRAM

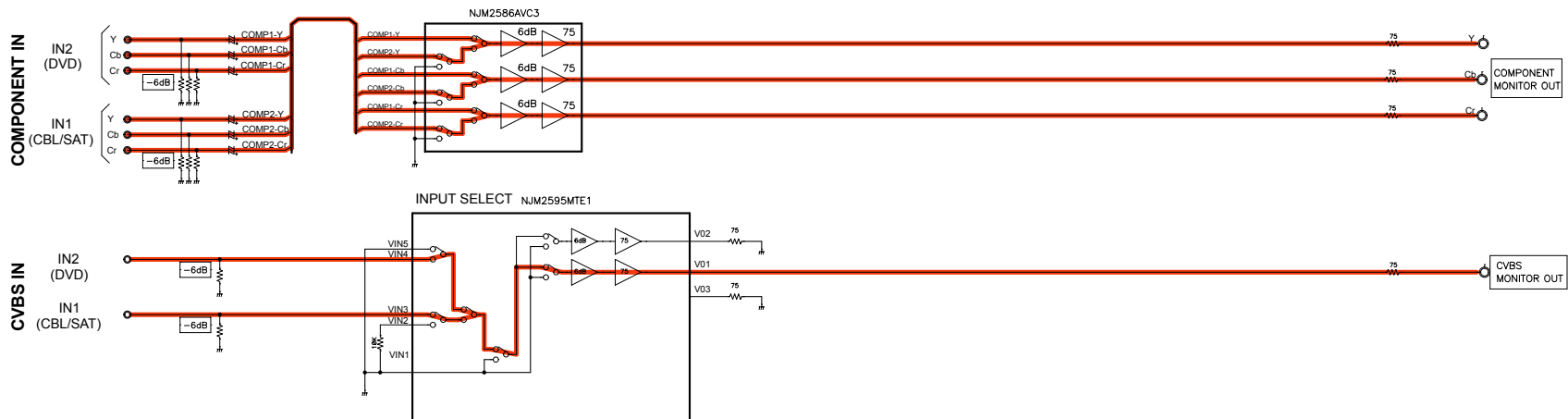
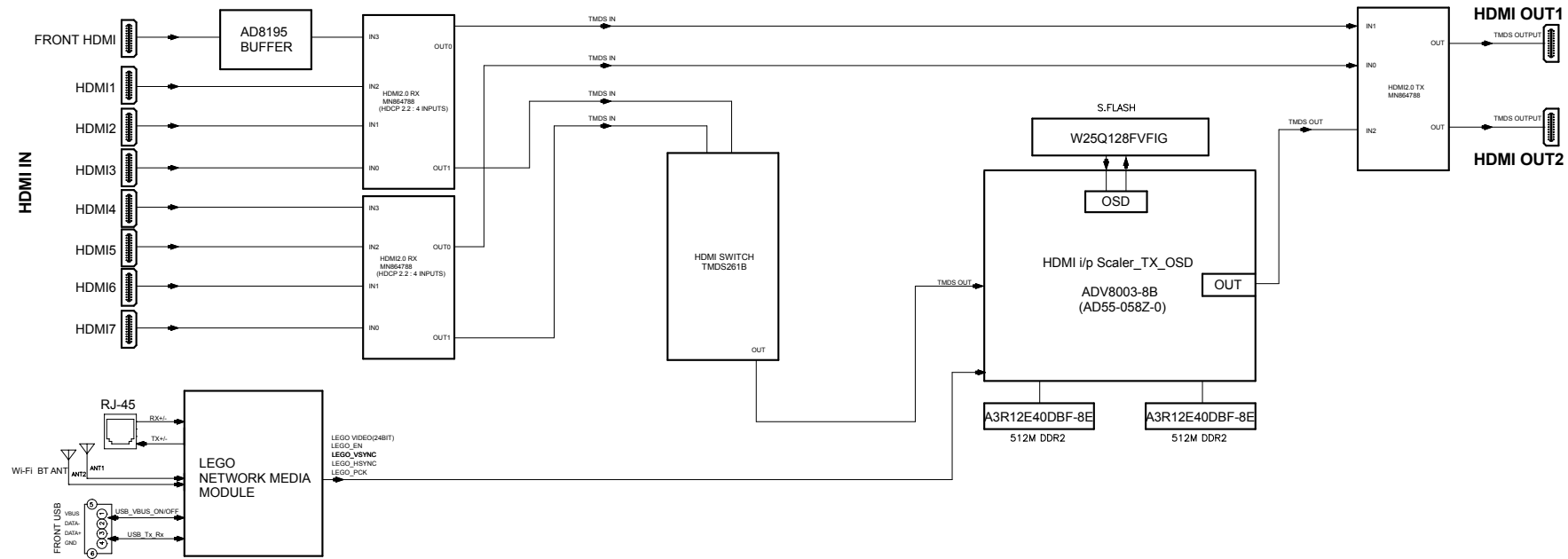

fig.08

AVR_S930H / X2400H VIDEO DIAGRAM

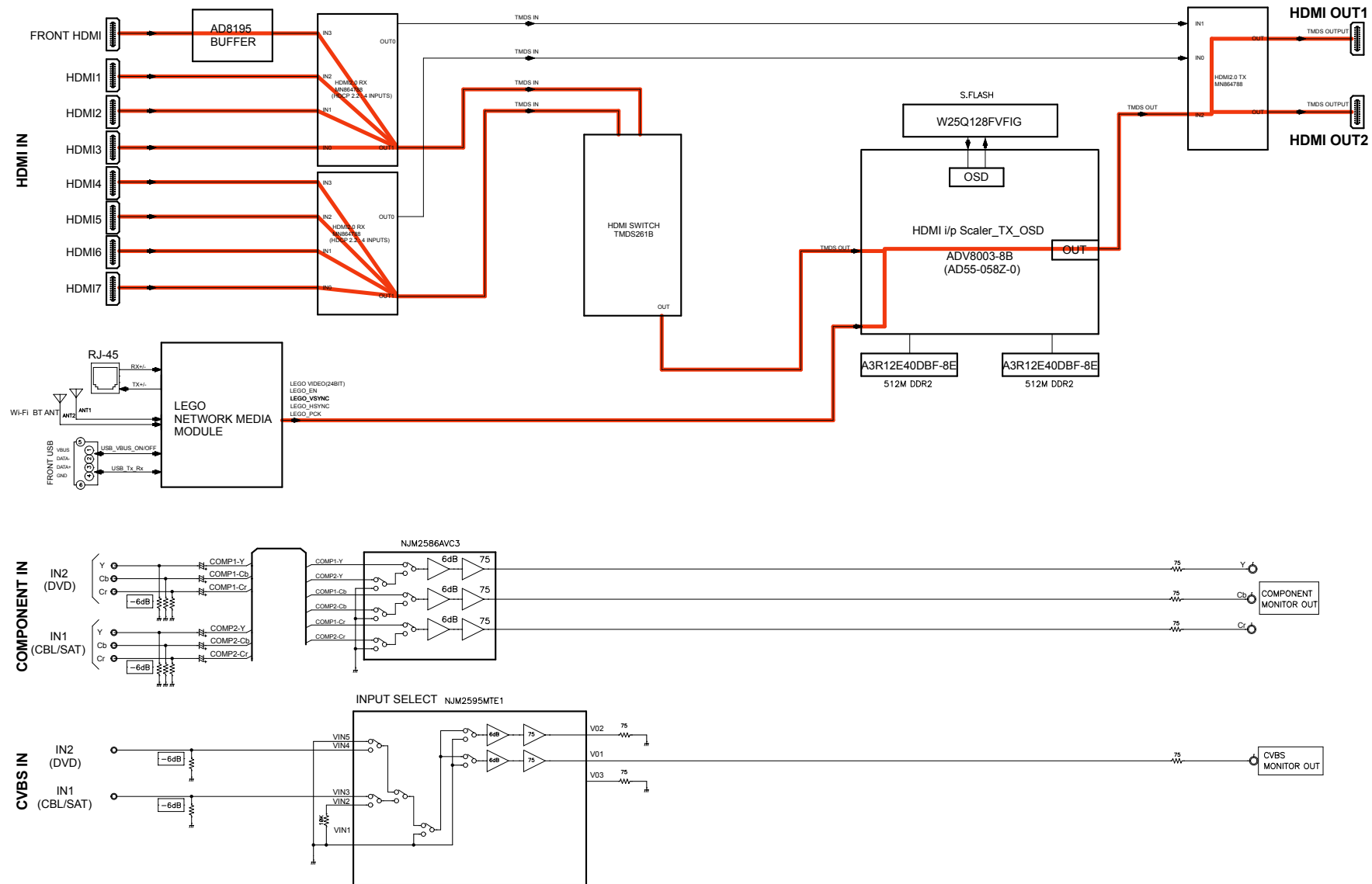

fig.09

AVR_S930H / X2400H VIDEO DIAGRAM

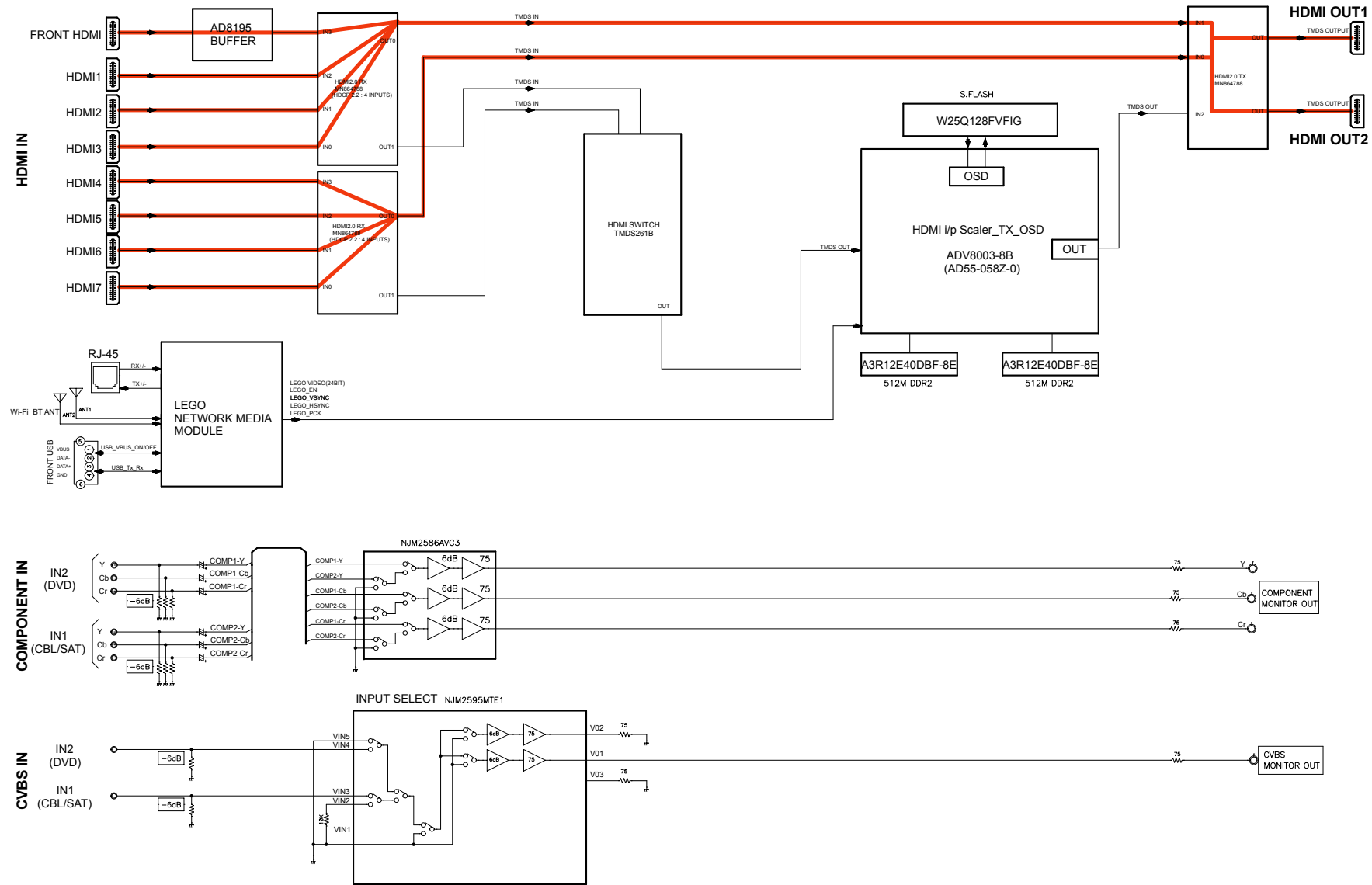

fig.10

AVR_S930H / X2400H VIDEO DIAGRAM

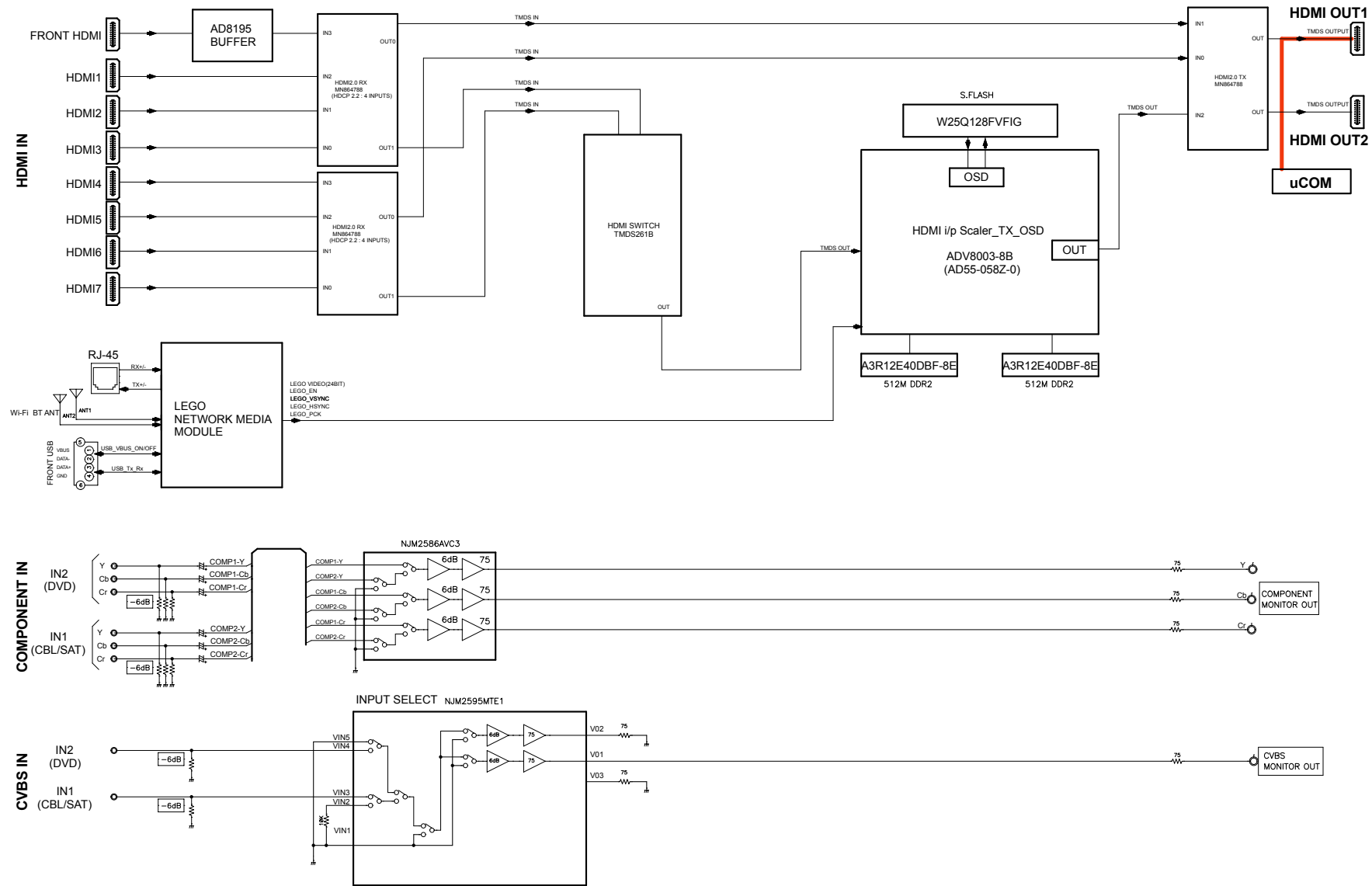

fig.11a

AVR_S930H / X2400H DIGITAL AUDIO DIAGRAM

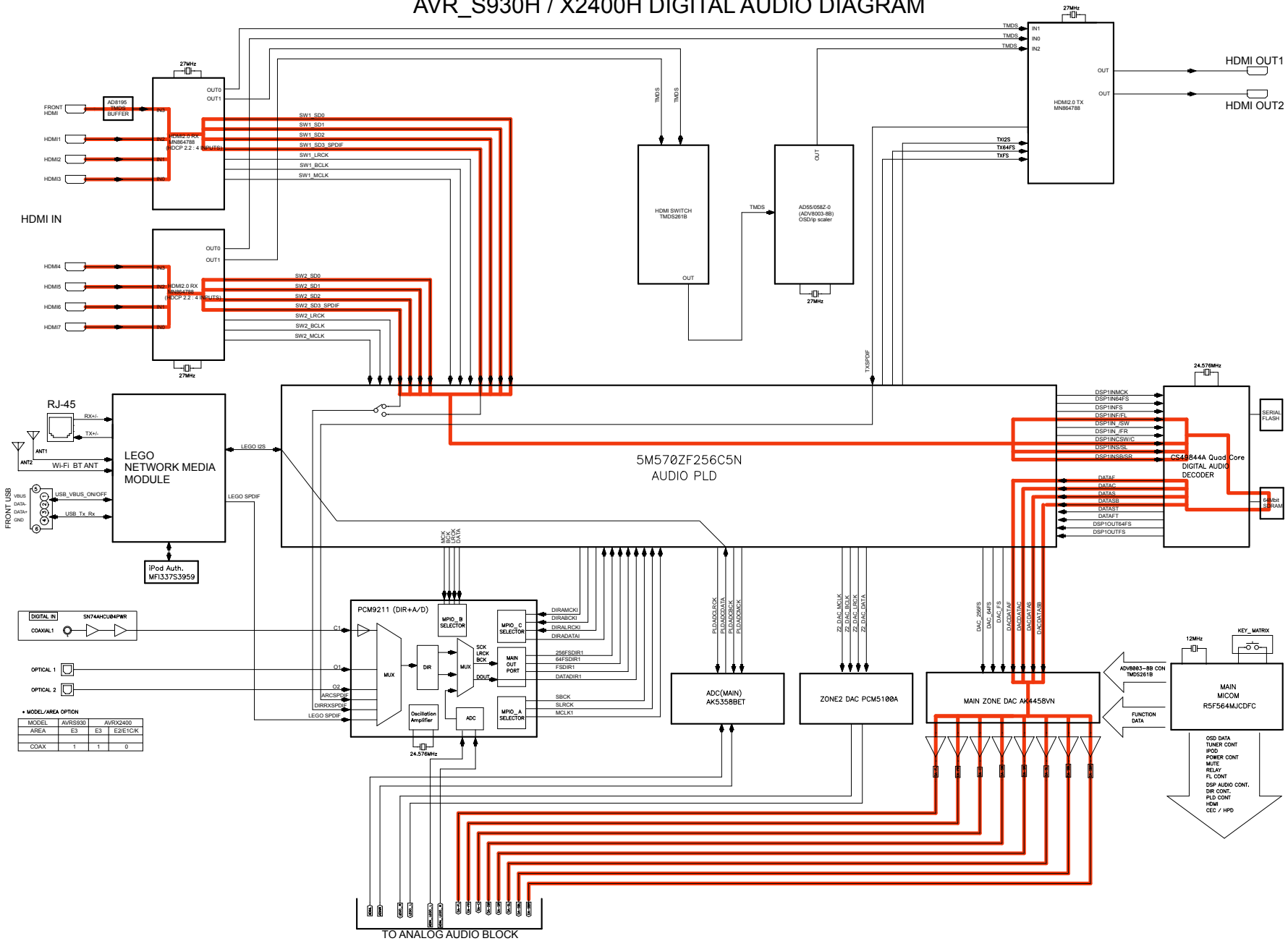

fig.11b

AVR_S930H / X2400H / ANALOG AUDIO DIAGRAM

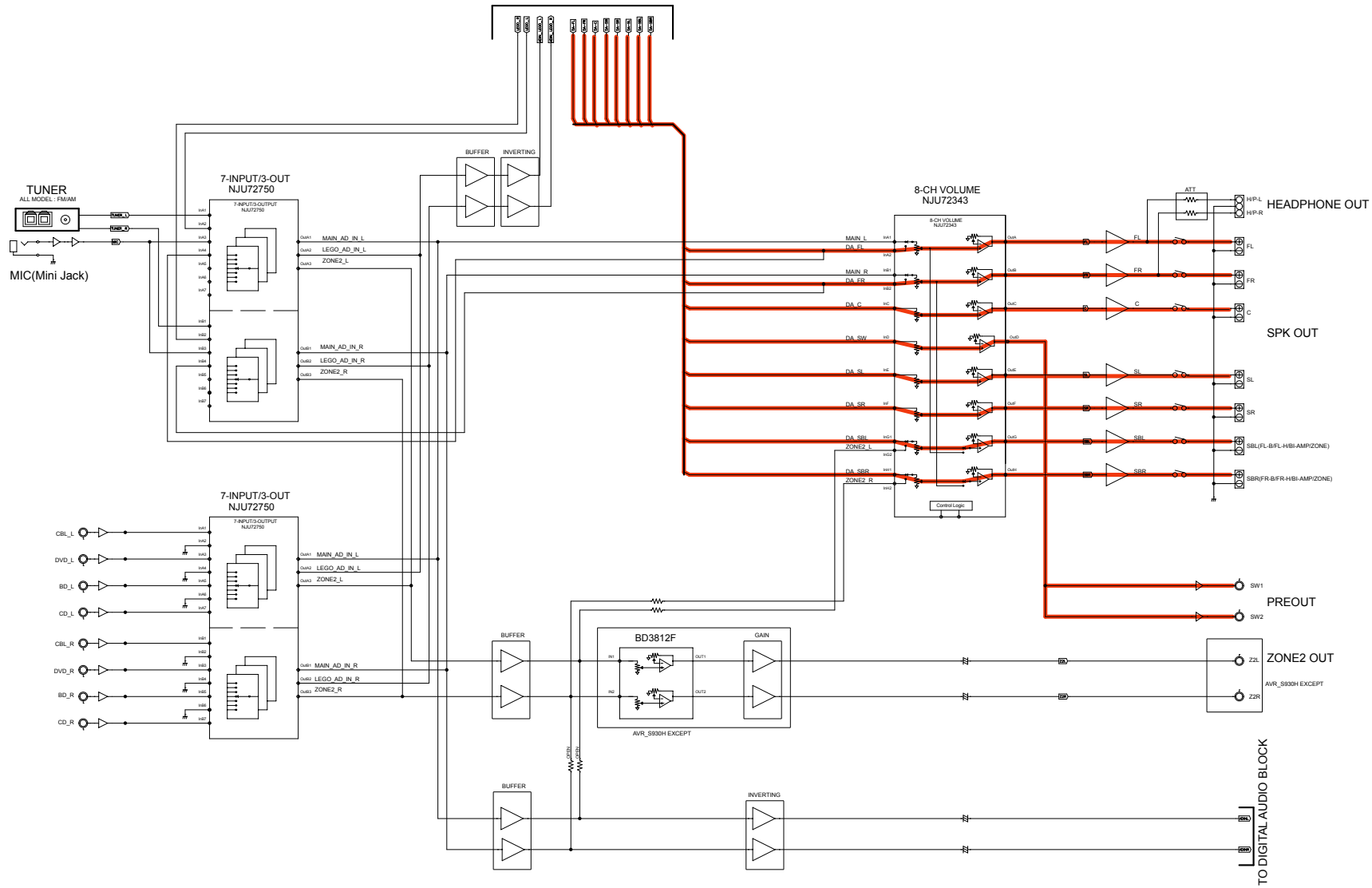

fig.12

AVR_S930H / X2400H DIGITAL AUDIO DIAGRAM

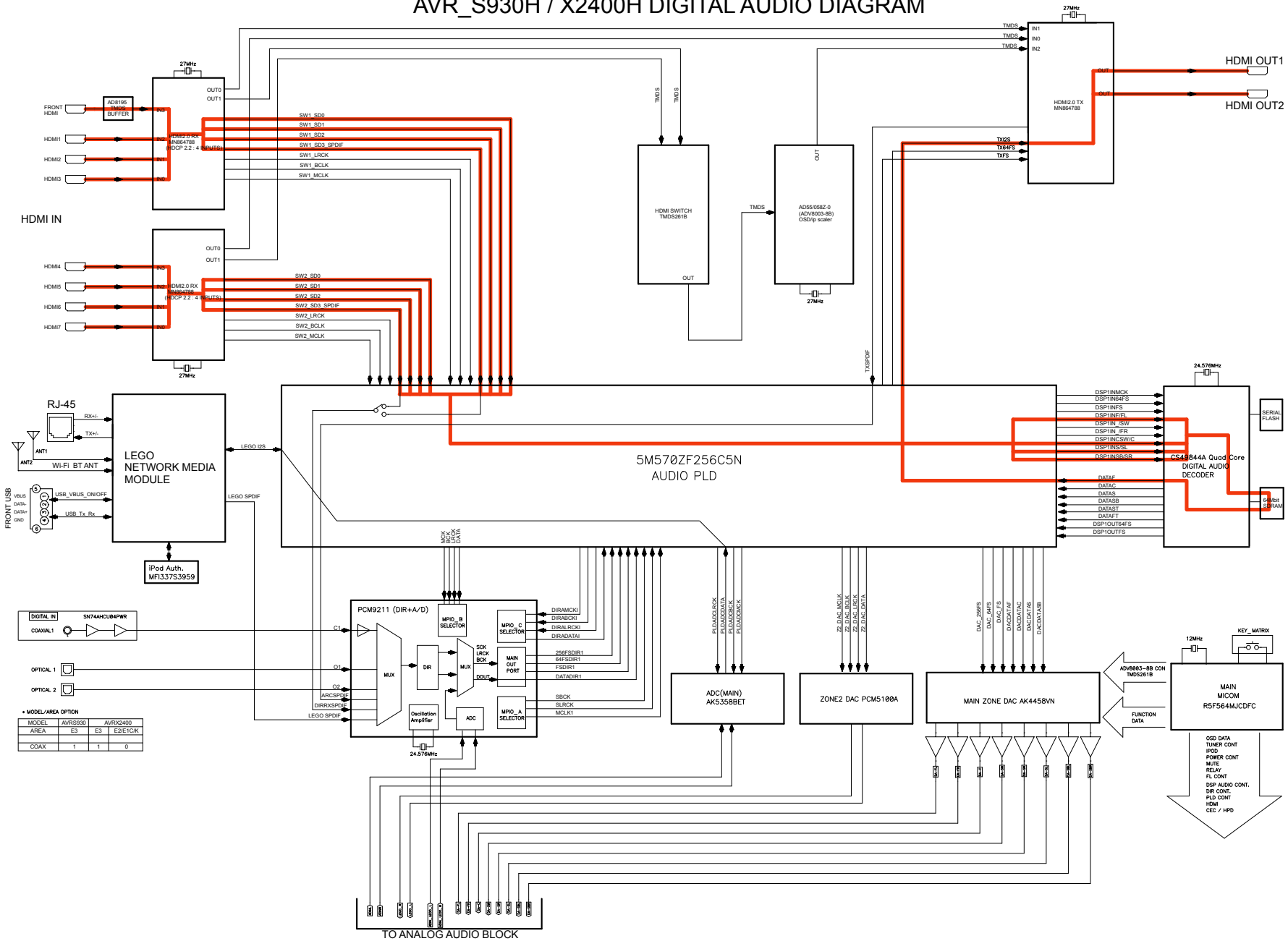
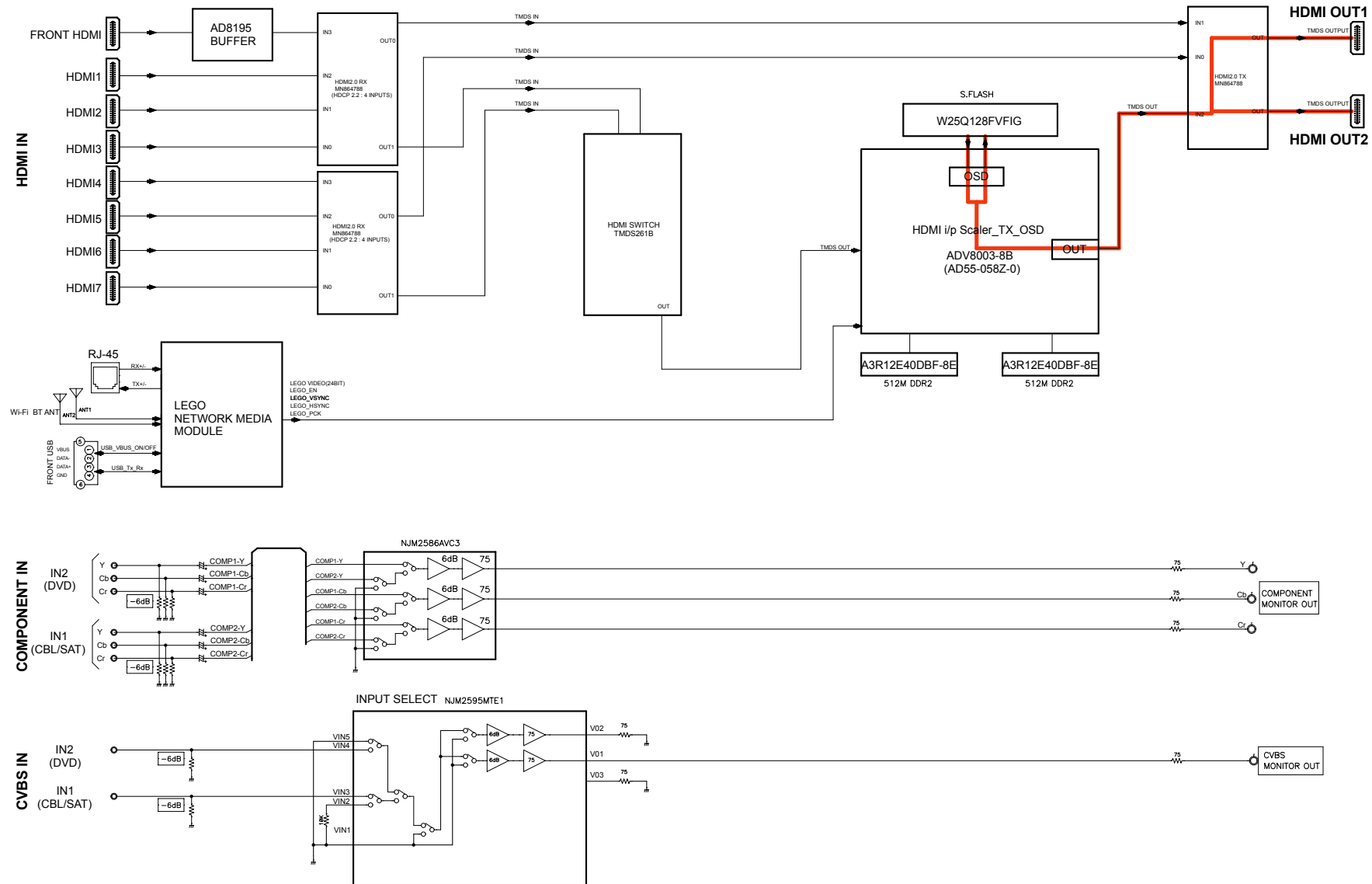

fig.13

AVR_S930H / X2400H VIDEO DIAGRAM



JIG FOR SERVICING

Use the following jigs (extension cable kit) when repairing the PCBs.
Order with your dealer for the jigs your dealer if necessary.

CAUTION : Incorrect connections may cause malfunction.

Connection of Jig for DIGITAL PCB

---Items to Be Prepared---

8U-110084S : EXTENSION UNIT KIT	:	1Set
Insulation sheet (Not supplied)	:	2 sheet
Ground lead (Not supplied)	:	2 pc

-Proceeding-

(1) Remove the screws.



(2) Remove the connector PCB.

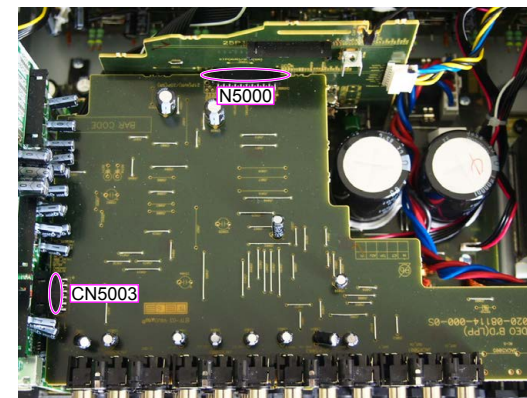
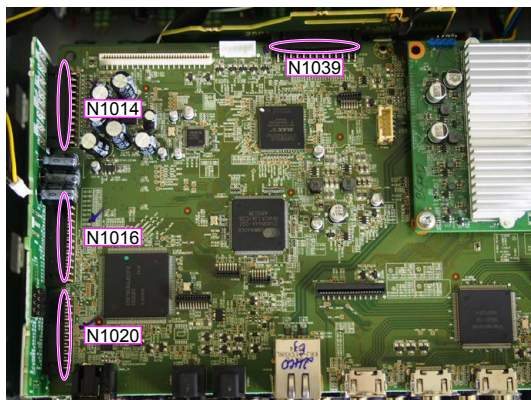

(3) Remove the DIGITAL PCB from the chassis and turn it over.
Place an insulation sheet larger than the PCB underneath the DIGITAL PCB.
※ Connect the earth of the PCB to the chassis using an earth wire, etc.

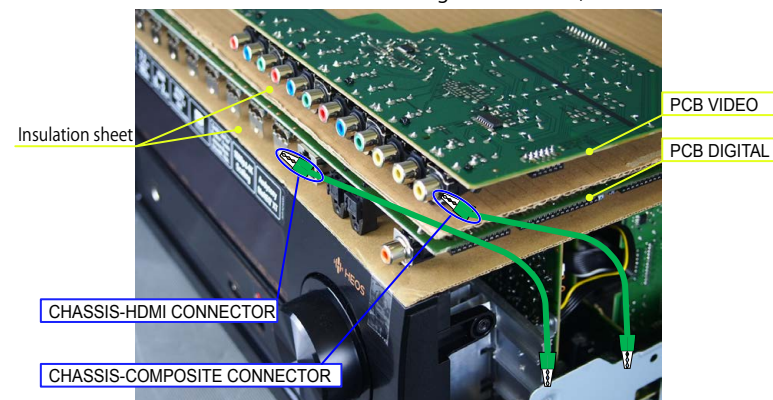

(4) Connect the expansion cables.

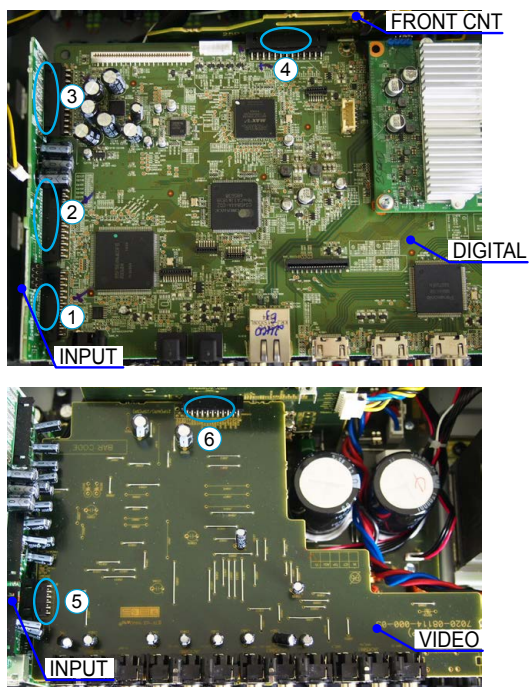

Board-to-Board Connections

No.	Pin	Ref. No.	PCB		Ref. No.	PCB
①	15pin	CP4200	INPUT	↔	N1020	DIGITAL
②	27pin	CP4205	INPUT	↔	N1016	DIGITAL
③	23pin	CP4201	INPUT	↔	N1014	DIGITAL
④	25pin	CP3401	FRONT CNT	↔	N1039	DIGITAL
⑤	11pin	CP4204	INPUT	↔	CN5003	VIDEO
⑥	21pin	CP5000	FRONT CNT	↔	CN5000	VIDEO

ADJUSTMENT

Adjusting Idling Current

1. Preparation

- (1) Prepare a DC voltmeter.
- (2) Place the unit under normal usage conditions, away from highly ventilated areas such as next to an air conditioning machine or electric fan.
The set requires an ambient temperature of 15°C to 30°C and standard humidity.
- (3) Settings of This Unit
 - POWER (Power source switch) STANDBY
 - SPEAKER (Speaker terminal) No load(Do not connect equipment such as speakers or dummy resistors.)

2. Adjustment Procedure

- (1) Remove the top cover and turn **VR401** (ALL Channel) of the AMP PCB counterclockwise(⤵) as far as possible.
- (2) Connect the DC Voltmeter to the test points.

FRONT-Lch	: CP501	: VR401
FRONT-Rch	: CP502	: VR402
CENTER ch	: CP503	: VR403
SURROUND-Lch	: CP504	: VR404
SURROUND-Rch	: CP505	: VR405
SURROUND-BACK Lch	: CP506	: VR406
SURROUND-BACK Rch	: CP507	: VR407
- (3) Connect the power cord to an outlet. Next, press the power button to turn on the power.
- (4) Set this unit as follows.

MASTER VOLUME	: "----" (⤵ min.)	: turn counterclockwise to the lowest position.
SPEAKER (Speaker terminal)	: No load	

(Do not connect equipment such as speakers or dummy resistors.)

MODE	: MCH STEREO
FUNCTION	: DVD
- (5) Turn **VR401** clockwise (⤴) and adjust the voltage of the test point to "**8.0mV ± 0.5mV DC**" within 2 minutes.
- (6) Check whether the voltage is within the range "**8.0mV +1mV/-2mV DC**" 10 minutes after adjustment.
- (7) Adjust the variable resistance of each channel using the same method.

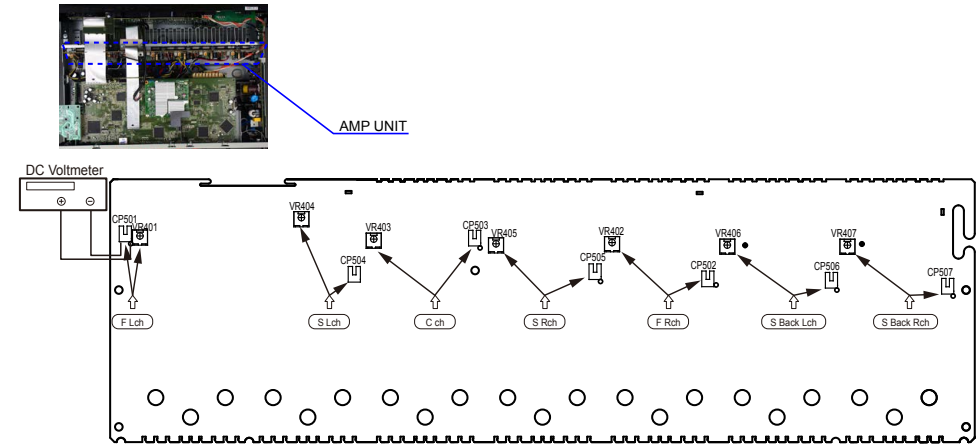

PROCEDURE AFTER REPLACING THE PCB.

PROCEDURE AFTER REPLACING THE U-COM, ETC.

FIRMWARE UPDATE PROCEDURE

1. Items necessary for update
2. Update preparation with a USB flash drive
3. Update method when the DIGITAL PCB or network module is replaced (Using a USB flash drive)
4. Update Method for Service Region Settings
5. Normal Firmware Update Method from USB Flash Drive
6. Normal Firmware Update Method from OTA
7. About the error codes

PROCEDURE AFTER REPLACING THE PCB.

The procedure after replacing the printed circuit boards is as follows.

(1) Change the resistor for setting the region.

Model Area	DIGITAL PCB	
	R1524	R1525
North America (E3)	OPEN	0
Europe (E2)	0	OPEN
China (E1C)	10k	10k
Japan (JP)	10k	22k
AVR-S930H	18k	3.3k

See the PCB below.

(2) Be sure to replace the software with the latest version.

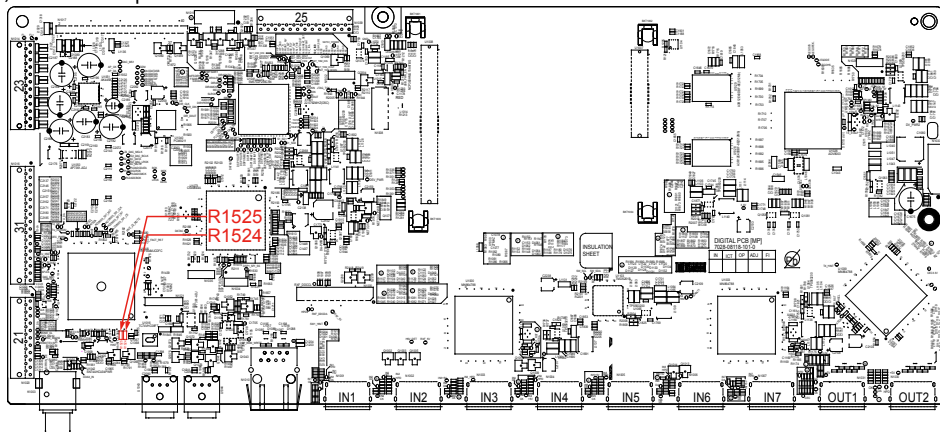

PROCEDURE AFTER REPLACING THE U-COM, ETC.

The procedure after replacing the u-COM (microprocessor), flash ROM, etc. is as follows.

Implement the update method when the DIGITAL PCB or network module is replaced.

PCB Name	Ref. No.	Description	Procedure after Replacement	Remark
DIGITAL	U1018	R5F564MJCDFC	B	SOFTWARE : Main
DIGITAL	U1025	MX25L6406EM2I-12G 64M	B	SOFTWARE : DSP ROM
DIGITAL	U1027	W25Q128JVFIQ	B	SOFTWARE : GUI ROM
DIGITAL	U1041	5M570ZF256C5N	C	SOFTWARE : AUDIO PLD
MODULE	P20	NETWORK MODULE	D, E	SOFTWARE : Network

Procedure after Replacement

- A** : The software has been written. The software is not written at the time of replacement.
- B** : The software has been written. The software may need to be rewritten by version updates. Check the version.
- C** : The software has not been written. The software needs to be written after replacement. See "[FIRMWARE UPDATE PROCEDURE](#)" for information on writing the software.
- D** : ""The software has been written. Be sure to replace the software with the latest version. See "[3. Update method when the DIGITAL PCB or network module is replaced \(Using a USB flash drive\)](#)" for information on writing the software.
- E** : An Electromagnetic wave absorption sheet [HS05-R050] needs to be attached to the back of NETWORK MODULE.
If the Electromagnetic wave absorption sheet [HS05-R050] has been removed, replace with a new sheet.
Service product numbers are set, for details see the parts list [REF No.52].
Refer to the figure below for details of the attachment position.

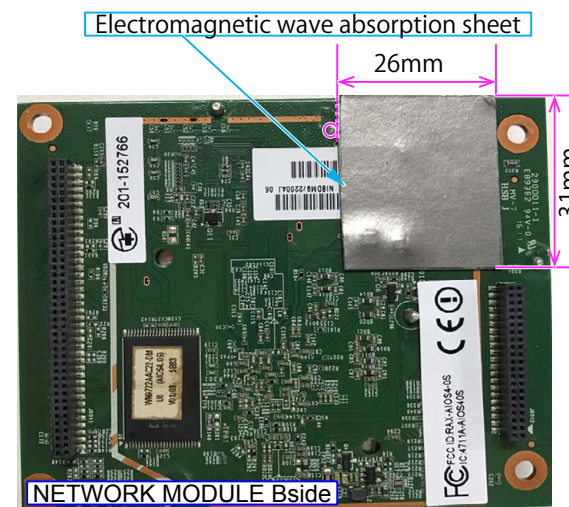

FIRMWARE UPDATE PROCEDURE

1. Items necessary for update

Items necessary for update are as follows.

Update Type	Needed Part for Update	Requirement	Offered / not Offered		
			Standard Service Equipment Not offered by D&M	Purchase from D&M Article code	Download from SDI
Via USB	USB flash drive (USB 2.0 : Min 1GB) • We recommend a USB memory device that has an LED installed.	Formatting FAT16 or FAT 32	X	-	"Table 1" or "Table 2"
Via OTA	Internet Connection by Broadband Circuit	-	X	-	-
	Modem	-	X	-	-
	Router	-	X	-	-
	Ethernet cable (CAT-5 or greater is recommended)	-	X	-	-

Table 1

Update download file when the DIGITAL PCB or network module is replaced

Model Name	Model Area	Download from SDI
AVR-X2400H	ALL	avr_40.prod.update.factory.xxxx.zip

Table 2

Update download file when the firmware is updated (Two files, "HW component" and "LEGO component")

Model Name	Model Area	Download from SDI	
		For HW component	For LEGO component
AVR-X2400HE3	North America (E3)	Product ID : 000100980100	DPMS_AVR-X2400HALL_LEGO_xxxx.zip heos_40.prod_x.xxx.xx.zip
AVR-X2400HE2	Europe (E2)	Product ID : 000100980200	
AVR-X2400HJP	Japan (JP)	Product ID : 000100980400	
AVR-X2400HE1C	China (E1C)	Product ID : 000100980500	
AVR-S930HE3	North America (E3)	Product ID : 000100980700	
			DPMS_AVR-S930HE3_LEGO_xxxx.zip

Caution in servicing

Electrical

Mechanical

Repair Information

Updating

2. Update preparation with a USB flash drive

You can update the firmware by downloading the latest version with USB flash drive.

2.1. Connecting to the USB flash drive

(1) Preparation

- Windows PC
- USB flash drive format : Prepare a USB flash drive formatted in FAT16 or FAT32.
※We recommend a USB flash drive that has an LED installed.

NOTE :

- Use a memory that supports USB2.0.
- Do not run the USB flash drive through a hub.
- Do not connect a computer to the USB port of this unit using a USB cable.
- Do not use an extension cable when connecting the USB flash drive.
- Save the update file on a blank USB flash drive for use.
- If a USB flash drive cannot be updated, replace it with a different USB flash drive and perform the update again.

2.2. Unzipping the Downloaded File

Unzip the downloaded file on your computer.

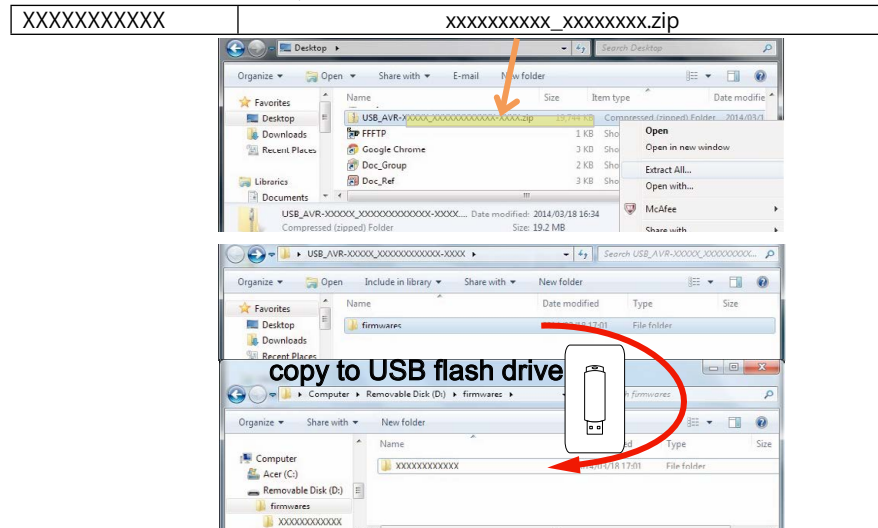

There are folders or files after unzipping.

Copy these folders or files onto the USB flash drive.

The folders or files must be placed in the root directory of the USB flash drive.

3. Update method when the DIGITAL PCB or network module is replaced (Using a USB flash drive)

3.1. File structure on USB flash drive

DIGITAL PCB or network module is replaced onto the USB flash drive in the following structure.

After unzipping the files, store them in the root of the same USB flash drive.

Model Area	Download from SDI
ALL	avr_40.prod.update.factory.xxxx.zip

USB flash drive root

- + avr_40.prod.update.factory
- + xxxxxxx.ota-download
- + heos_40.prod.update.factory

xxxxxx : Model name
zz : Region

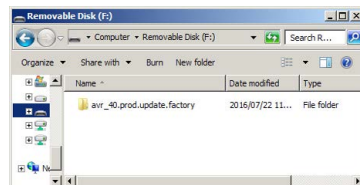

3.2. Start the update.

NOTE :

- Remove the LAN cable from this unit when updating. (Do not connect to a wired or wireless network.)
- The GUI menu setting details and image quality adjustment setting details are initialized when Firmware Factory Restore is performed. Therefore, take a note of the setting details beforehand and reconfigure the settings after update.

- Press the power button to turn on the power.
- Wait for this unit to start up.
- Set the input source to HEOS Music. Check that the display is as shown below.

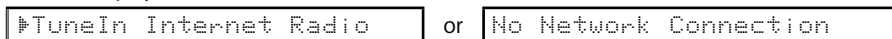

Content of the display is scrolled.

- Insert the USB flash drive into the USB port.

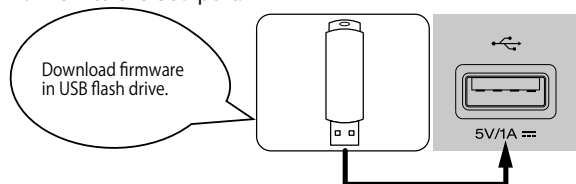

- USB Update starts automatically. The Standby LED lights red.

Display during USB update

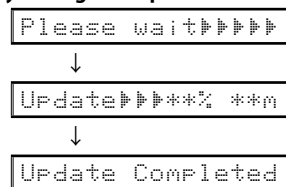

It takes a maximum of approximately 25 minutes for update to complete.

- The unit restarts when update is complete.
 - When update is complete, the folder name on the USB flash drive changes to "avr_40.prod.update.factory.done". To use the files again, delete the ".done" part.

- Execute Firmware Factory Restore.

AVR-X2400H

- While holding down buttons "TUNER PRESET CH-" and "DIMMER" simultaneously, press the power button to turn on the power.

AVR-S930H

- While holding down buttons "BAND" and "MODE" simultaneously, press the power button to turn on the power.

Display during Firmware Factory Restore

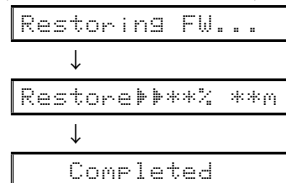

It takes approximately 15 minutes for Firmware Factory Restore to complete.

- Execute Service Region Settings. See "4. Update Method for Service Region Settings"
- Check that the version is the specified version. See "1. Version Display Mode"
- If necessary, use OTA or the USB flash drive to update the firmware to the newest version.
 - We recommend using the firmware update method using OTA. See "5. Normal Firmware Update Method from USB Flash Drive" or "6. Normal Firmware Update Method from OTA"

---Cautions on Firmware Update---

- Do not remove the USB flash drive until updating is completed.
- Do not turn off the power until updating is completed.
- It takes a maximum of approximately 25 minutes for update to complete. Once an update is started, normal operations cannot be performed until it is completed.

4. Update Method for Service Region Settings

Copy the Service Region Settings from the USB flash drive to this unit.

4.1. Creating a Service Region Settings file

(1) Click [Start button] - [Accessories] - [notepad] on the PC to launch the notepad.

(2) Enter "TEXT".

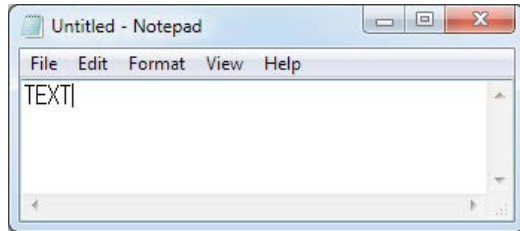

(3) Click "File", and then click "Save As...".

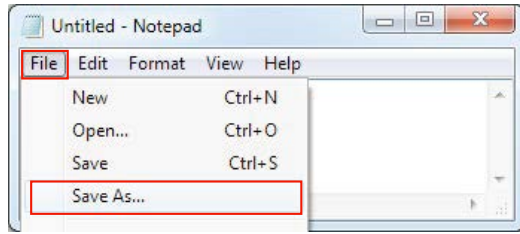

(4) Enter the file name and click the Save button.

NOTE : Enter the file name in double quotation marks. (The file extension is not required.)

Service Region	File name
North America	"denon-config-locale-set-1"
Europe	"denon-config-locale-set-2"
Japan	"denon-config-locale-set-3"
Australia	"denon-config-locale-set-4"
Korea	"denon-config-locale-set-5"
China	"denon-config-locale-set-6"
Israel	"denon-config-locale-set-7"

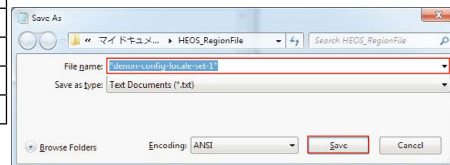

(5) Copy the files created on the USB flash drive.

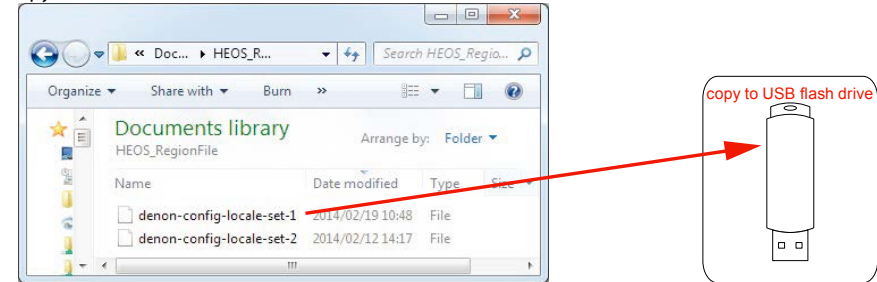

4.2. Starting Service Region Settings

NOTE :

- Remove the LAN cable from this unit when updating. (Do not connect to a wired or wireless network.)
- We recommend a USB memory device that has an LED installed.

(1) Press the power button to turn on the power.

(2) Wait for this unit to start up.

(3) Set the input source to HEOS Music.

Check that the display is as shown below.

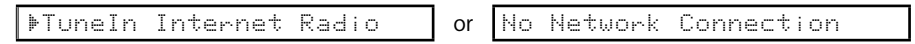

Content of the display is scrolled.

(4) Insert the USB flash drive into the USB port.

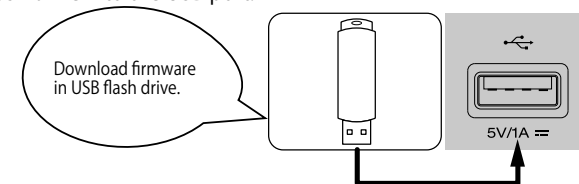

(5) Wait for at least 10 seconds before removing the USB flash drive.

(If the USB flash drive has an LED, this LED will be flashing. Remove the USB flash drive when the LED

stops flashing.)

5. Normal Firmware Update Method from USB Flash Drive

5.1. File structure on USB flash drive

Copy the normal update files onto the USB flash drive in the following structure.

After unzipping the HW component USB update files for the target model and LEGO USB update files, store them in the root of the same USB flash drive.

Model Area	Download from SDI	
	For HW component	For LEGO component
North America (E3)	DPMS_AVR-X2400HALL_LEGO_XXXX.zip Product ID : 000100980100	heos_40.prod_x.xxx.xx.zip
Europe (E2)	DPMS_AVR-X2400HALL_LEGO_XXXX.zip Product ID : 000100980200	
Japan (JP)	DPMS_AVR-X2400HALL_LEGO_XXXX.zip Product ID : 000100980400	
China (E1C)	DPMS_AVR-X2400HALL_LEGO_XXXX.zip Product ID : 000100980500	
North America (E3)	DPMS_AVR-S930HE3_LEGO_XXXX.zip Product ID : 000100980700	

USB flash drive root

- + AVR-X2400Hxx_XXXX.update.auto
- + heos_40.prod.update.x-xxx-xx

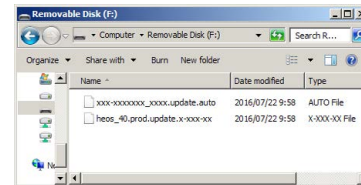

5.2. Start normal update

NOTE :

- Remove the LAN cable from this unit when updating.
(Do not connect to a wired or wireless network.)

- Press the power button to turn on the power.
- Wait for this unit to start up.
- Set the input source to HEOS Music.
Check that the display is as shown below.

▶TuneIn Internet Radio or No Network Connection

Content of the display is scrolled.

- Insert the USB flash drive into the USB port.

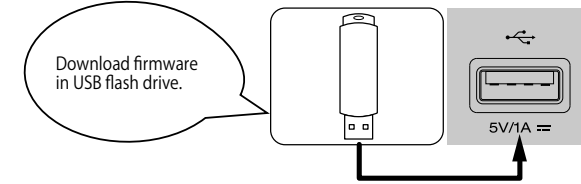

- USB Update starts automatically.
The Standby LED lights red.
Display during USB update

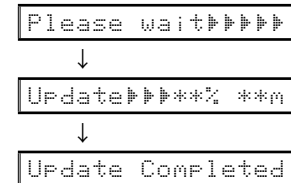

It takes a maximum of approximately 25 minutes for update to complete.

- The unit restarts when update is complete.

- After updating the firmware, check the version.
See "1. Version Display Mode"

---Cautions on Firmware Update---

- Do not remove the USB flash drive until updating is completed.
 - Do not turn off the power until updating is completed.
 - It takes a maximum of approximately 25 minutes for update to complete.
- Once an update is started, normal operations cannot be performed until it is completed. The GUI menu settings and image adjustment settings of this unit may be initialized. Note down the settings before updating, and set them again after updating.

6. Normal Firmware Update Method from OTA

Download the latest firmware from our website and update the firmware.

6.1. Network Connection

(1) System Requirements

- Internet Connection by Broadband Circuit
- Modem
- Router
- Ethernet cable (CAT-5 or greater is recommended)

(2) Setting

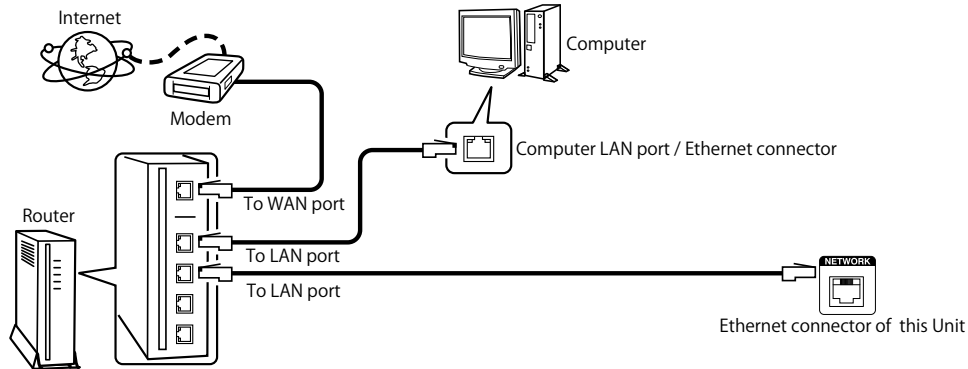

6.2. Check and update the firmware

Check if there is a firmware update available. It is also possible to check approximately how long the update will take.

(1) Press the "SETUP" button on the remote control to display the GUI menu.

(2) Press the cursor button to select "General" → "Firmware" → "Update" → "Check for Update".

(3) Check update

- If the firmware version is anything other than the latest version, select "Update Now" to update the firmware.
- "No update required. Latest version installed." is displayed when the firmware version is up to date.

(4) OTA Update starts automatically.
The Standby LED lights red.

Display during OTA update

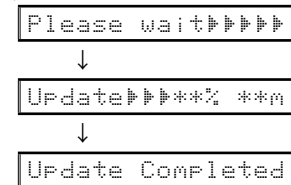

It takes a maximum of approximately 25 minutes for update to complete.

(5) The unit restarts when update is complete.

(6) After updating the firmware, check the version.
See "1. Version Display Mode"

---Cautions on Firmware Update---

- For the update procedure, a proper broadband Internet connection environment and settings are required.
 - Do not turn off the power until updating is completed.
 - It takes a maximum of approximately 25 minutes for update to complete.
- Once an update is started, normal operations cannot be performed until it is completed. The GUI menu settings and image adjustment settings of this unit may be initialized. Note down the settings before updating, and set them again after updating.

7. About the error codes

See the table below for details on error codes and solutions when updating the firmware.
Error codes are displayed in 4 digits, **YYXX**(**YY** : DeviceID, **XX** : ErrorCode).

Update▶▶▶▶**% **n



Update Error**YYXX** Update Error**YYXX** (**YY** : DeviceID, **XX** : ErrorCode)

↓ ↑ The display is alternately displayed.

Please check you

Content of the display is scrolled.

Remedies

Error Code (YYXX) (DeviceID/ErrorCode)	Remedies
000A	"Connection failed. Please check your network, then try again."
0009	"Update failed. Please check your network, then try again."
0009	"Upgrade failed. Please check your network, then try again."
YY00 YY01 YY02 YY03 YY04 YY07	"Please check your network, unplug and reconnect the power cord, and try again."
YY00 YY01 YY02 YY03 YY04 YY07	"Please unplug and reconnect the power cord, and try again."
0005	"Incompatible update file found on the USB device. Please check the file."
0006	"Update file is corrupted. Please check the file."
000B	"Please contact customer service in your area." ※ Check the power supply and communication lines of each device.

Device ID table

Device ID (YY)	Device Name
00	General
01	Main CPU
0E	Main FBL (No used)
11	DSP1 or DSP
12	DSP2 ※ Except : AVR-S730H/S930H/X1400H/X2400H/X3400H
13	DSP3 ※ Except : AVR-S730H/S930H/X1400H/X2400H/X3400H
19	DSP4 ※ Except : AVR-S730H/S930H/X1400H/X2400H/X3400H
15	Audio PLD
22	Video PLD ※ Except : AVR-S730H/S930H/X1400H/X2400H
2A	GUI
33	LEGO

Error Code table

Type code (XX)	Description
00	Logical error
01	Error during erasing
02	Error during writing
03	Error during verifying
04	No access for the component
05	Package mismatched. Product ID, package version un-matched of the package manifest
06	Unpack dis-available of component package file
07	Time out
08	Latest firmware has already installed.
09	Error during download
0A	Error connection
0E	Hardware Error

---Checking the Firmware Version After the Update---

After updating the firmware, check the version.

See "1. Version Display Mode"

DENON[®]
www.denon.com