



McCall



REACH-IN AND ROLL-IN Refrigerators, Freezers and Heated Holding Cabinets

Installation, Use & Care Manual

This manual is updated as new information and models are released.
Visit our website for the latest manual. www.manitowocfsg.com

America's Quality Choice in Refrigeration
Part Number 14479 2/08

Manitowoc
Foodservice Group



Safety Notices

As you work on Manitowoc equipment, be sure to pay close attention to the safety notices in this manual. Disregarding the notices may lead to serious injury and/or damage to the equipment.

Throughout this manual, you will see the following types of safety notices:

Warning

Text in a Warning box alerts you to a potential personal injury situation. Be sure to read the Warning statement before proceeding, and work carefully.

Caution

Text in a Caution box alerts you to a situation in which you could damage the equipment. Be sure to read the Caution statement before proceeding, and work carefully.

Procedural Notices

As you work on Manitowoc equipment, be sure to read the procedural notices in this manual. These notices supply helpful information which may assist you as you work.

Throughout this manual, you will see the following types of procedural notices:

Important

Text in an Important box provides you with information that may help you perform a procedure more efficiently. Disregarding this information will not cause damage or injury, but it may slow you down as you work.

NOTE: Text set off as a Note provides you with simple, but useful, extra information about the procedure you are performing.

Read These Before Proceeding:

Caution

Proper installation, care and maintenance are essential for maximum performance and trouble-free operation of your Manitowoc equipment. Read and understand this manual. It contains valuable care and maintenance information. If you encounter problems not covered by this manual, do not proceed, contact Manitowoc Foodservice Group. We will be happy to provide assistance.

Important

Routine adjustments and maintenance procedures outlined in this manual are not covered by the warranty.

Warning

PERSONAL INJURY POTENTIAL

Do not operate equipment that has been misused, abused, neglected, damaged, or altered/modified from that of original manufactured specifications.

NOTE: SAVE THESE INSTRUCTIONS.

We reserve the right to make product improvements at any time. Specifications and design are subject to change without notice.

Table of Contents

Section 1

General Information

Model Numbers	1-1
How to Read a Model Number	1-4
Reach-in Example	1-4
Roll-in Example	1-4
Model/Serial Number Location	1-5
Warranty	1-5
Parts Coverage	1-5
Labor Coverage	1-5
Exclusions from Warranty	1-5
Warranty Service	1-5
Warranty Certificate	1-6

Section 2

Installation Instructions

General	2-1
Installing the Cabinet	2-1
Cabinet Location Guidelines	2-1
Uncrating	2-2
Leveling the Cabinet	2-3
Leveling a Reach-in Cabinet	2-3
Leveling a Roll-in Cabinet	2-3
Shelf/Tray Slide Installation	2-3
Shelves	2-3
Electrical Requirements	2-4
Electrical Specifications	2-4
Heated Cabinets	2-4
Refrigerators and Freezers	2-5

Section 3

Operation

Sequence of Operation	3-1
Refrigerators – Self-contained	3-1
Refrigerators – Remote	3-1
Freezers – Self-contained	3-2
Freezers – Remote	3-2
Condensate Water Removal – Refrigerators and Freezers	3-3

Table of Contents (continued)

Defrost Systems	3-3
General	3-3
Defrost Settings	3-3
Temperature Controls	3-4
Refrigerators and Freezers	3-4
Reach-in Heated Cabinets	3-4
Roll-in Heated Cabinets	3-4
Loading Shelves – Reach-in Cabinets	3-5
Loading Carts – Roll-in Cabinets	3-5
Adjustments and Calibrations	3-6
Adjustments	3-6
Calibrations	3-7

Section 4 Maintenance

Cleaning Recommendations	4-1
Exterior	4-1
Interior	4-1
Cleaning the Condenser Coil – Refrigerators and Freezers	4-2
Condenser Cleaning Procedures	4-2
Cleaning the Fan Blades and Motor	4-2
Component Replacement Procedures	4-3
Evaporator Fan Motor – 1 Section Refrigerators and Freezers	4-3
Light Switch	4-5
Evaporator Fan Motor – 2 and 3 Section Refrigerators and Freezers	4-6
Temperature Control – Refrigerators & Freezers	4-7
Temperature Control – Heated Holding Cabinets	4-8
Defrost Heater Element	4-9
Evaporator Drain Pan Heater Element	4-11
Heater Element – Heated Holding Cabinets	4-12
Thermal Limit Switch – Heated Holding Cabinets	4-12
Blower Fans – Heated Holding Cabinets	4-12
Digital Thermometer Display and Probe	4-13
Digital Thermometer Transformer	4-15
Door Handle – Solid Doors	4-16
Door Handle – Glass Doors	4-17
Door Hinge – Solid Doors	4-17
Door Gasket – Solid Doors	4-18
Door Gasket – Glass Doors	4-19
Door Lock – Solid Doors	4-19
Vinyl Breaker Strips – Door Jambs	4-20

Table of Contents (continued)

Anti-condensate Door Heater Wires 4-21
Defrost Termination/Fan Delay Switch 4-21

Section 5
Before Calling for Service

Checklist 5-1
Evaporator Checklist 5-2

THIS PAGE INTENTIONALLY LEFT BLANK

Section 1

General Information

Model Numbers

This manual covers the following models:

Reach-in Refrigerators and Freezers	
1 Section Reach-in Refrigerators	1-1020, 1-102001E 2-2020, 2-202001E 4-4020, 4-402001E
2 Section Reach-in Refrigerators	1-1045, 1-104501E 2-2045, 2-204501E 4-4045, 4-404501E
3 Section Reach-in Refrigerators	1-1070, 1-107001E 2-2070, 2-207001E 4-4070, 4-407001E
1 Section Reach-in Freezers	1-1020F, 1-1020F01E 2-2020F, 2-2020F01E 4-4020F, 4-4020F01E
2 Section Reach-in Freezers	1-1045F, 1-1045F01 2-2045F, 2-2045F01 4-4045F, 4-4045F01
3 Section Reach-in Freezers	1-1070F, 1-1070F01 2-2070F, 2-2070F01 4-4070F, 4-4070F01
-10° Freezers	1-1024UF, 1-1045UF 2-2024UF, 2-2045UF 4-4024UF, 4-4045UF
7000 Series Reach-in Refrigerators	7-7020, 7-7045, 7-7070
7000 Series Reach-in Freezers	7-7020FT, 7-7045FT, 7-7070F
Narrow Body Reach-in Refrigerators	1-1020N, 2-2020N, 4-4020N
Narrow Body Reach-in Freezers	1-1020F, 2-2020F, 4-4020F
Wide Body Reach-in Refrigerators	1-1024, 2-2024, 4-4024
Wide Body Reach-in Freezers	1-1024F, 2-2024F, 4-4024F

Pass-thru Refrigerators	
1 Section Pass-thru Refrigerators	1-1020P 2-2020P 4-4020P
2 Section Pass-thru Refrigerators	1-1045P 2-2045P 4-4045P
3 Section Pass-thru Refrigerators	1-1070P 2-2070P 4-4070P

Glass Door Reach-in Refrigerators	
1 Section Glass Door Reach-ins	1-1020GD, 2-2020GD, 4-4020GD
2 Section Glass Door Reach-ins	1-1045GD, 1-1045X, 1-1045PGD, 1-1045XPGD, 2-2045GD, 2-2045X 2-2045PGD, 2-2045XPGD 4-4045GD, 4-4045X 4-4045PGD, 4-4045XPGD
3 Section Glass Door Reach-ins	1-1070GD, 1-1070PGD, 2-2070GD, 2-2070PGD, 4-4070GD, 4-4070PGD

Dual Temps	
1 Section Dual Temps	DT1-102001E DT2-202001E DT4-402001E
2 Section Dual Temps	DT1-1045 DT2-2045 DT4-4045
3 Section Dual Temps	DT1-1070 DT1-1070F DT2-2070 DT2-2070F DT4-4070 DT4-4070F
Wide Body Dual Temps	DT1-102401E DT2-202401E DT4-402401E

Roll-in Refrigerators and Freezers	
Roll-in Refrigerators (65" cart 1 Section)	L1-1001 L2-2001 L4-4001 L1-1001RT L2-2001RT L4-4001RT L1-1001GD L2-2001GD L4-4001GD
Roll-in Refrigerators (65" cart 2 Section)	L1-1002 L2-2002 L4-4002 L1-1002RT L2-2002RT L4-4002RT L1-1002GD L2-2002GD L4-4002GD
Roll-in Refrigerators (65" cart 3 Section)	L1-1003 L2-2004 L4-4003 L1-1003GD L2-2003GD L4-4003GD
Roll-in Refrigerators (72" cart 1 Section)	H1-1001 H2-2001 H4-4001 H1-1001RT H2-2001RT H4-4001RT H1-1001GD H2-2001GD H4-4001GD
Roll-in Refrigerators (72" cart 2 Section)	H1-1002 H2-2002 H4-4002 H1-1002RT H2-2002RT H4-4002RT H1-1002GD H2-2002GD H4-4002GD
Roll-in Freezers (65" 1 Section)	L1-1001FE L2-2001FE L2-4001FE
Roll-in Freezers (65" 2 Section)	L1-1002FE L2-2002FE L4-4002FE

Heated Holding Cabinets	
Heated Holding Cabinets (1 Section)	1020-H 2020-H 4020-H
Heated Holding Cabinets (2 Section)	1-1045-H 2045-H 4045-H
Narrow Body Heated Holding Cabinets	1020N-H
Pass-thru Heated Holding Cabinets	1020-HP 2020-HP 4020-HP 1045-HP 2045-HP 4045-HP

Roll-in Heated Holding Cabinets	
Roll-in Heated Holding Cabinets (1 Section)	L1-1001H L2-2001H L4-4001H L1-1001HRT L2-2001HRT L4-4001HRT H1-1001H H2-2001H H4-4001H H1-1001HRT H2-2001HRT H4-4001HRT
Roll-in Heated Holding Cabinets (2 Section)	L1-1002H L2-2002H L4-4002H L1-1002HRT L2-2002HRT L4-4002HRT H1-1002H H2-2002H H4-4002H

Bakery Cabinets	
Bakery Retarders (1 Section)	H5-5001 H5-5001RT
Bakery Retarders (2 Section)	H5-5002 H5-5002RT
Bakery Proofers (1 Section)	P5-5001
Bakery Proofers (2 and 3 Section)	P-5002 P-5003
Pizza Proofer (2 Section)	H4-4002HD

Base Mount Refrigerators and Freezers	
Base Mount Refrigerators (24" Wide)	1-1014 2-2014 4-4014
Base Mount Refrigerators (27.5" Wide)	1-1018 2-2018 4-4018
Base Mount Freezers (24" Wide)	1-1014F 2-2014F 4-4014F
Base Mount Freezers (27.5" Wide)	1-1018F 2-2018F 4-4018F

How to Read a Model Number

REACH-IN EXAMPLE

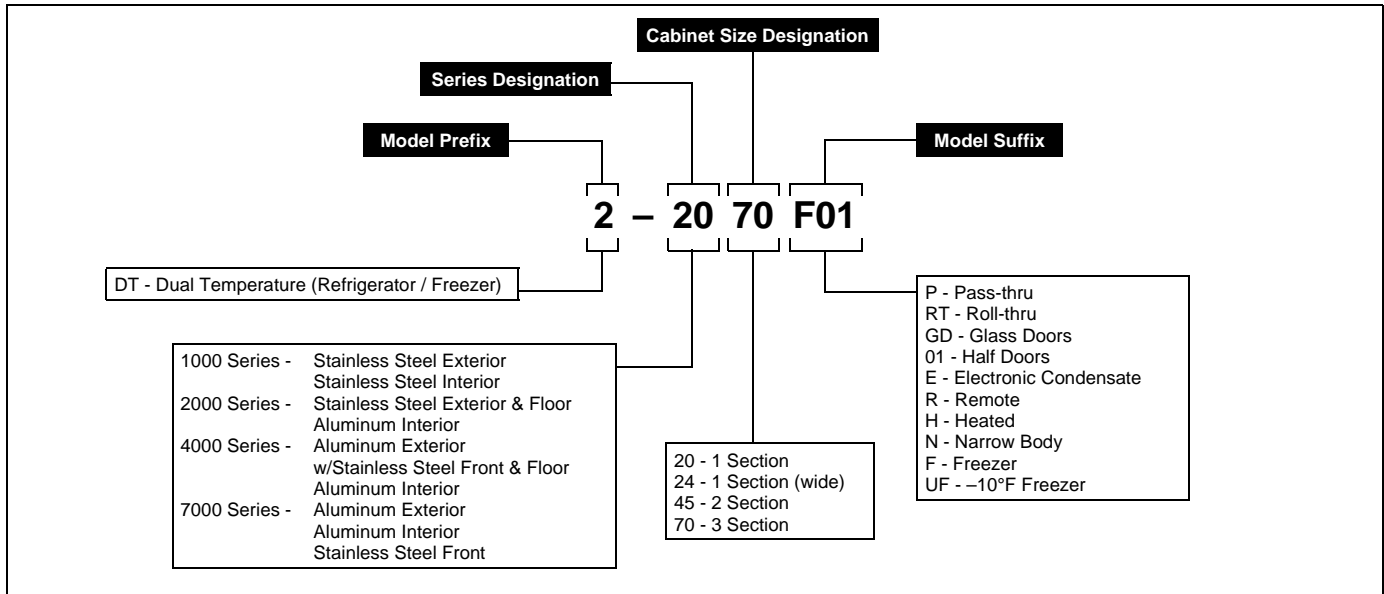

ROLL-IN EXAMPLE

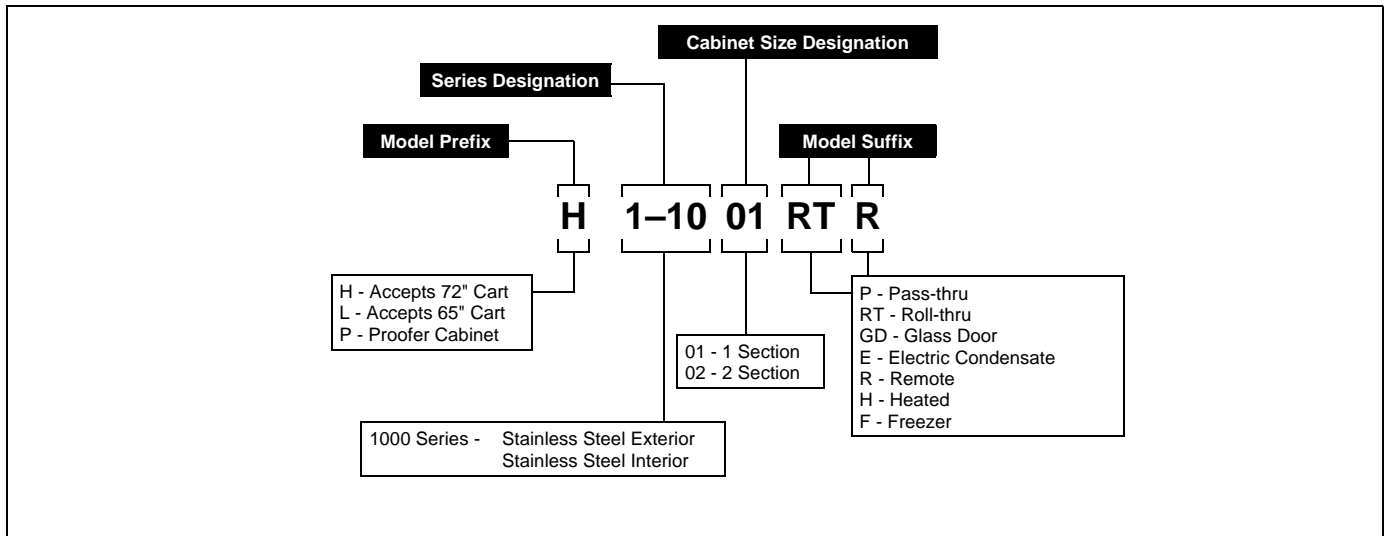

Model/Serial Number Location

The McCall data plate which includes the model number and serial number, as well as important electrical and technical information, is located on the left interior wall of the cabinet at approximately eye level.

For convenience and quick reference, record the model and serial numbers, voltage, and installation date in the spaces below:

Model Number _____

Serial Number _____

Voltage _____

Installation Date _____

Warranty

Warranty coverage on a McCall reach-in begins on the date it is installed. Please read the warranty certificate included with the cabinet for details.

PARTS COVERAGE

- 1. McCall warrants the cabinet, refrigeration, and mechanical components against defects in materials and workmanship for a period of one (1) year from the date of original installation.

LABOR COVERAGE

Labor is covered for (1) year.

EXCLUSIONS FROM WARRANTY

- 1. Normal start-up, maintenance, adjustments, and cleaning.
- 2. Damage caused by improper installation of the McCall cabinet as outlined in this manual.
- 3. Labor charges resulting from the inaccessibility of the McCall cabinet.
- 4. Damage to parts due to misuse, abuse, neglect, or accidents.
- 5. Premium labor rates due to holidays, overtime, travel time, mileage, etc., not specifically authorized by McCall prior to service.
- 6. Miscellaneous tools or materials charges.
- 7. Repairs due to modifications to the McCall cabinet or refrigeration system not authorized by McCall in writing.
- 8. Claims for indirect or consequential damages, including food spoilage or product loss.
- 9. Damage due to faulty or incorrect power supply, floods, storms, or other acts or God.

Warranty Service

To ensure warranty coverage, a qualified service company, authorized by McCall, must perform the warranty repair.

If the dealer the McCall reach-in was purchased from does not perform warranty service, please contact the McCall Service Department for assistance.

Warranty Certificate



Parts & Labor Warranty

McCall warrants to the original Purchaser-User its product as per the following schedule:

All Parts:	One year from original installation.
Labor:	One year from original installation.
Compressor:	One year from original installation.

The obligation of **McCall** under this warranty is limited to **McCall** repairing or replacing, free of cost to Purchaser-User, any part or parts, that to the judgement of **McCall** show evidence of defect, and provided that upon **McCall** authorization, said part or parts to be returned to **McCall**, transportation prepaid, for inspection and judgement. This warranty covers only **McCall** manufactured self-contained cabinets.

This warranty is issued only to the original Purchaser-User, is not transferable, applies only to unit installed within the United States of America, its territories and Canada and is in lieu of all other warranties expressed or implied. **McCall** neither assumes nor authorizes any other person to assume for **McCall** any liability not herein stated.

McCall shall not be liable for any damage or delays occurring in transit, for any default or delays in performance caused by any contingency beyond its contract including wars, government restrictions or restraints, strikes, short or reduced supply of raw materials, fire, flood or other acts of God, nor for damage or loss of any products, property, loss of income or profit due to malfunctioning of sold unit.

Manufacturing Plant 4 81 West Holly Street 4 Parsons, TN 38363
Warranty Service: 1-888-REACH-IN 4 Sales Phone: 731-847-5570
Sales FAX: 731-847-9012 4 Parts FAX: 731-847-5552
www.mccall.com

Section 2

Installation Instructions

General

Caution

These instructions are of the utmost importance in assuring that the McCall cabinet operates as designed, and must be followed closely.

Please call your local McCall dealer or the McCall Service Department if you have any questions regarding proper installation.

Installing the Cabinet

Caution

When selecting a permanent location for the cabinet, observe the following guidelines. Failure to do so may cause reduced performance and efficiency, cause damage, and void your warranty.

CABINET LOCATION GUIDELINES

- Install the cabinet in an indoor environment only.
- The air temperature entering the refrigerator or freezer condenser should be between 55°F (13°C) and 100°F (38°C).
- Allow space for air circulation in the refrigeration condensing unit compartment on refrigerators and freezers. The minimum space requirements are:
 - 10" (25 cm) on top
 - 4" (10 cm) at the back
 - 4" (10 cm) on each side
- The floor must be strong enough to support the weight of the cabinet and product load.

Caution

A fully loaded reach-in or roll-in cabinet can weigh more than 3,000 pounds.

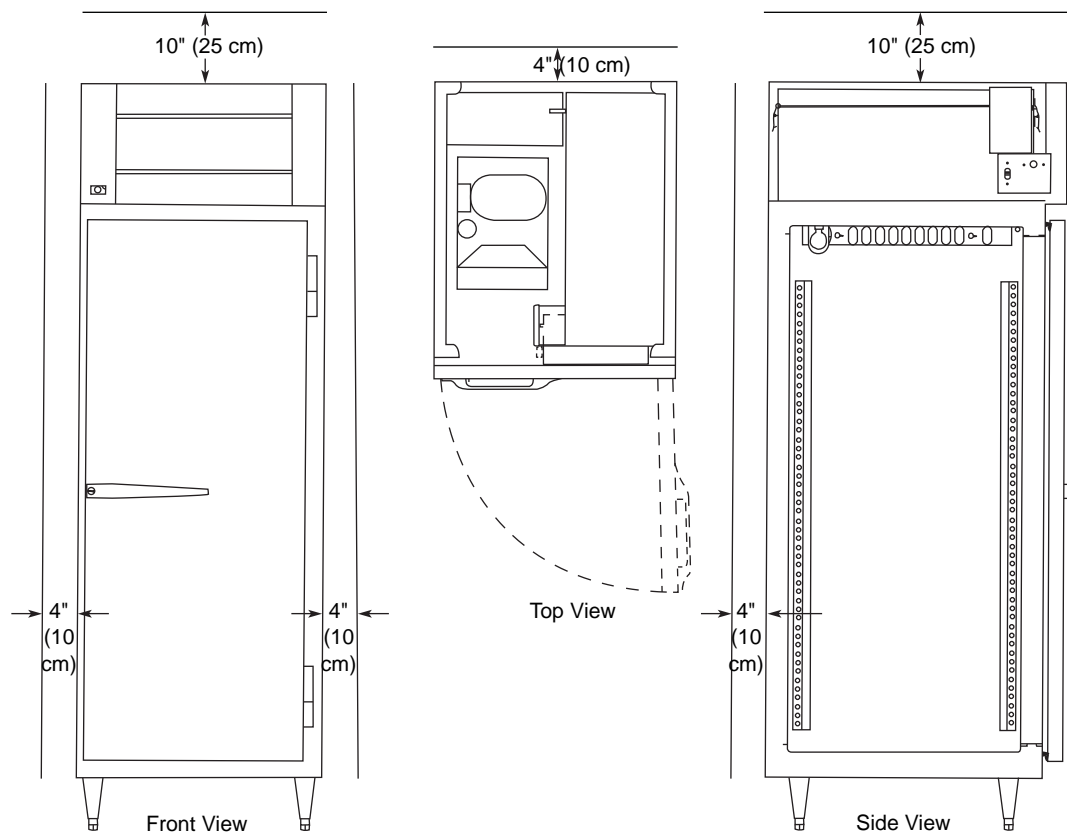

Cabinet Clearances (Typical Single Door Cabinet Shown)

E-3042-B

Uncrating

Warning

Never attempt to tilt the cabinet alone. Always use two or more people when tilting the cabinet to remove the shipping skid or to move it through doorways.

1. Remove the bottom shipping skid using one of the methods below:
 - Lay the cabinet on its back, elevated and supported by wooden blocks. Remove the skid mounting bolts and separate the skid from the cabinet.
 - Tilt the cabinet from side to side and remove the mounting bolts. Support the weight of the cabinet apart from the skid.
2. Install the legs or casters and torque them to 360 inch-pounds. Refer to the drawing at right.

NOTE: Roll-in style cabinets do not have legs or casters. Refer to the drawing at right for ramp installation.

3. Return the cabinet to the upright position.
4. Remove any remaining crating materials.

Caution

If the cabinet was placed on its back while moving it or while removing the bottom shipping skid, wait at least two hours after returning the cabinet to the upright position before starting the refrigeration system.

Caution

Never use sharp instruments to cut the plastic or cardboard crating materials. Damage to the cabinet exterior may result.

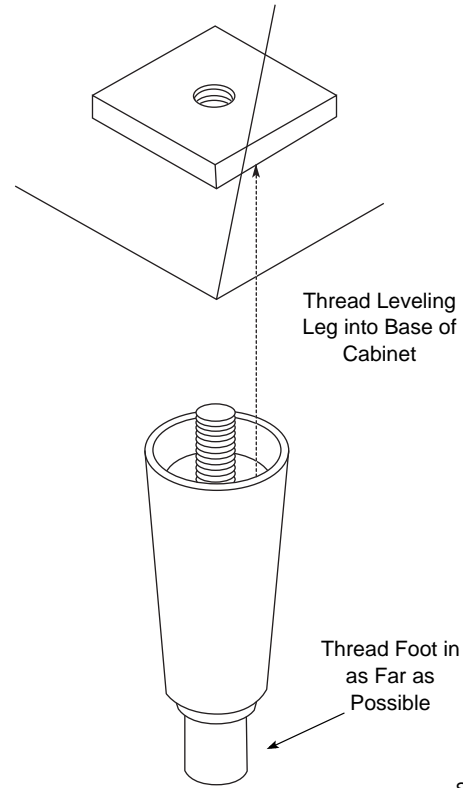

SV1342

Installing Cabinet Legs

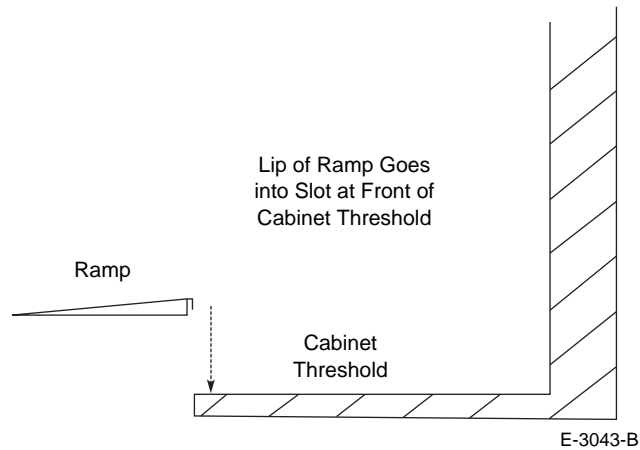

E-3043-B

Ramp Installation

Leveling the Cabinet

The cabinet must be leveled after it is positioned in its permanent location. This ensures proper door alignment on all cabinets, and adequate condensate water drainage and proper refrigeration system operation on refrigerators and freezers.

Follow the appropriate procedure below.

LEVELING A REACH-IN CABINET

Caution

If casters are installed instead of legs, the floor must be leveled before final positioning of the cabinet.

1. Place a level on top of the cabinet.
2. Turn the leveling foot of the lowest corner leg to center the bubble in the level.
3. Adjust each of the other corners until the bubble is centered and the cabinet is stable.
4. Re-check the cabinet from side to side and from front to rear with the level.

LEVELING A ROLL-IN CABINET

Roll-in cabinets are designed to sit directly on the floor without legs or casters.

1. Use shims to level the cabinet if necessary.
2. Seal the bottom perimeter of the cabinet to the floor with NSF-approved silicone.
3. Install the ramp(s). Refer to the drawing on the previous page.

Shelf/Tray Slide Installation

SHELVES

1. Determine the desired shelf location.

NOTE: The shelves may be located at any position in 1" (2.5 cm) increments. Optimum spacing is one shelf near the bottom of the cabinet, one shelf near center height, and one shelf at eye level (refer to drawing).

2. Install four clips per shelf, one at each corner. The shelf clips slip into the 3/8" holes and slide down.
3. Make sure that the clips are level from side to side and from front to rear at each corner.
4. Install the shelves with the smaller wires running from front to back.

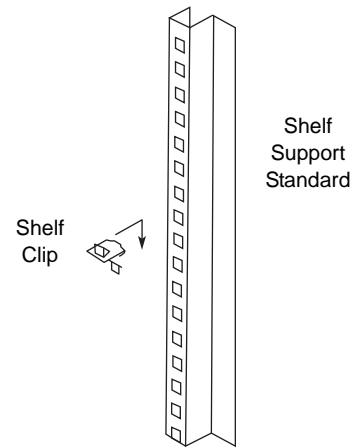

Shelf Installation

SER.3

Electrical Requirements

All cord-connected units should be plugged into a grounded and properly sized electrical outlet with appropriate overcurrent protection. Refer to the drawing below for electrical plug configurations.

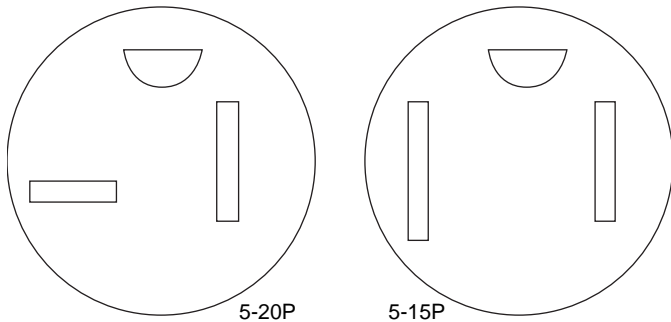

5-20P and 5-15P Electrical Plug Configurations

SER.4

All permanently connected (hard wired) units are fitted with a power junction box and 6" pigtail wires for power connection.

Connect one end of the power line to the pigtail from the cabinet junction box. Connect the other end to a properly sized electrical source.

As a rule, the power lines must be enclosed inside a conduit secured to the power junction boxes on both ends.

⚠ Caution

Power installation must be in compliance with the National Electrical Code and all applicable local and state codes.

⚠ Warning

Never use an extension cord.
Never alter the power cord or plug supplied with the cabinet.

After the power source has been connected, turn on the main power switch. The switch is located on the cabinet top, behind the front louvered panel.

Electrical Specifications

HEATED CABINETS

Product Type	Self-contained Base Models	Voltage/ Cycles/Phase	Total Amps	Maximum Fuse Size	ANSI Electrical Plug Configuration
Reach-in Heated Cabinets	20H	115/60/1	14.6	20 amp	5-20P
		230/60/1	7.5	15 amp	Hard-wired
	20HP	115/60/1	14.6	20 amp	5-20P
		230/60/1	7.5	15 amp	Hard-wired
	45H	115/60/1	14.6	20 amp	5-20P
		230/60/1	7.5	15 amp	Hard-wired
45HP	115/60/1	14.6	20 amp	5-20P	
	230/60/1	7.5	15 amp	Hard-wired	
Roll-in Heated Cabinets	H01H	240/60/1	6.5	15 amp	Hard-wired
	H01HRT	240/60/1	6.5	15 amp	Hard-wired
	L01H	240/60/1	6.5	15 amp	Hard-wired
	L01HRT	240/60/1	6.5	15 amp	Hard-wired
	H02H	240/60/1	7.0	15 amp	Hard-wired
	L02H	240/60/1	7.0	15 amp	Hard-wired
	L02HRT	240/60/1	7.0	15 amp	Hard-wired

REFRIGERATORS AND FREEZERS

Product Type	Self-contained Base Models	Voltage/ Cycles/Phase	Total Amps	Maximum Fuse Size	ANSI Electrical Plug Configuration
Reach-in Refrigerators	20,20P	115/60/1	8.0	15 amp	5-15P
	20GD	115/60/1	11.5	15 amp	5-15P
	20PGD	115/60/1	16.0	20 amp	5-20P
	45	115/60/1	10.0	15 amp	5-15P
	45P	115/60/1	12.0	15 amp	5-15P
	45GD	115/60/1	16.0	20 amp	5-20P
	45PGD	208/230/60/1	15.0	20 amp	Hard-wired
	45XPGD	208/230/60/1	17.0	20 amp	Hard-wired
	70	115/60/1	13.3	20 amp	5-20P
	70P	208/230/60/1	11.6	15 amp	Hard-wired
	70GD	208/230/60/1	15.3	20 amp	Hard-wired
	70PGD	208/230/60/1	14.4	20 amp	Hard-wired
Reach-in Freezers	20F	115/60/1	12.4	15 amp	5-15P
	20FP	115/60/1	15.0	20 amp	5-20-P
	20FGDE	115/60/1	16.0	20 amp	5-20-P
	45F	115/60/1	16.0	20 amp	5-20-P
	45FP	208/230/60/1	—	15 amp	Hard-wired
	45FGD	208/230/60/1	—	20 amp	Hard-wired
	70F	208/230/60/1	—	25 amp	Hard-wired
	70FP	208/230/60/1	—	25 amp	Hard-wired
70FGD	208/230/60/1	—	25 amp	Hard-wired	
Roll-in Refrigerators	H01	115/60/1	12.0	15 amp	5-15P
		208/230/60/1	7.5	15 amp	Hard-wired
	H01RT	115/60/1	12.0	15 amp	5-15P
		208/230/60/1	7.8	15 amp	Hard-wired
	H01GD	115/60/1	13.1	15 amp	5-15P
		208/230/60/1	9.0	15 amp	Hard-wired
	L01	115/60/1	12.0	15 amp	5-15P
		208/230/60/1	7.5	15 amp	Hard-wired
	L01RT	115/60/1	12.0	15 amp	5-15P
		208/230/60/1	7.8	15 amp	Hard-wired
	L01GD	115/60/1	13.1	15 amp	5-15P
		208/230/60/1	9.0	15 amp	Hard-wired
	H02	115/60/1	12.0	15 amp	5-15P
		208/230/60/1	9.1	15 amp	Hard-wired
	H02RT	208/230/60/1	—	20 amp	Hard-wired
	H02GD	208/230/60/1	—	20 amp	Hard-wired
	L02	115/60/1	12.0	15 amp	5-15P
		208/230/60/1	9.1	15 amp	Hard-wired
L02RT	208/230/60/1	—	15 amp	Hard-wired	
L02GD	208/230/60/1	—	20 amp	Hard-wired	
H03	208/230/60/1	—	20 amp	Hard-wired	
L03	208/230/60/1	—	20 amp	Hard-wired	
L03GD	208/230/60/1	—	25 amp	Hard-wired	

REFRIGERATORS AND FREEZERS (Continued)

Product Type	Self-contained Base Models	Voltage/ Cycles/Phase	Total Amps	Maximum Fuse Size	ANSI Electrical Plug Configuration
Roll-in Freezers	L01FE	115/60/1	16.0	20 amp	5-20P
		208/230/60/1	10.6	20 amp	Hard-wired
	L02FE	208/230/60/1	—	25 amp	Hard-wired
Base-mount Refrigerators	14	115/60/1	10.0	15 amp	5-15P
	18	115/60/1	10.0	15 amp	5-15P
	36	115/60/1	12.0	15 amp	5-15P
Base-mount Freezers	14F	115/60/1	12.0	15 amp	5-15P
	18F	115/60/1	12.0	15 amp	5-15P
	36F	115/60/1	15.0	20 amp	5-20P

Section 3

Operation

Sequence of Operation

REFRIGERATORS – SELF-CONTAINED

Cooling Cycle

With the main ON/OFF switch in the ON position, the current flows, energizing the evaporator fan motors.

Current also flows through the closed contacts of the temperature control, energizing the condenser fan motor and the compressor.

Off Cycle

When the temperature control senses the proper temperature, it opens, shutting off the refrigeration system.

The refrigeration system remains off until the temperature control senses approximately 38°F (3.3°C). (This also keeps the evaporator defrosted.) At that time, the temperature control closes and starts the refrigeration system.

REFRIGERATORS – REMOTE

Cooling Cycle

With the main ON/OFF switch in the ON position, the current flows, energizing the evaporator fan motors.

Current also flows through the closed contacts of the temperature control, energizing the liquid line solenoid valve. The increase in suction pressure causes the contacts on the low pressure switch to close, energizing the refrigeration system.

Off Cycle

When the temperature control senses the proper temperature, it opens, shutting off the liquid line solenoid valve. The drop in suction pressure causes the low pressure switch to open, de-energizing the refrigeration system.

The refrigeration system remains off until the temperature control senses approximately 38°F (3.3°C). (This also keeps the evaporator defrosted.) At that time, the temperature control closes and starts the refrigeration system.

FREEZERS – SELF-CONTAINED**Cooling Cycle**

With the main ON/OFF switch in the ON position, the current flows, energizing the automatic defrost time clock.

Current also flows through the closed contacts of the temperature control, energizing the condenser fan motor(s) and the compressor.

With contact N closed on the automatic defrost time clock, current will flow through the normally open (N.O.) light/fan switch contacts (with the door closed).

When the evaporator coil temperature reaches 30 to 35°F (-1.1 to 1.7°C), the defrost end and fan delay thermostat closes, energizing the evaporator fans.

Defrost Cycle

At preset times on the automatic defrost time clock, the contacts switch to defrost the evaporator. Contact N opens, de-energizing the evaporator fan motor(s). Contact #4 opens, de-energizing the refrigeration system. Contact #1 closes, energizing the evaporator defrost heater.

As the evaporator temperature rises, the defrost end and fan delay thermostat opens to terminate the defrost cycle. Contact #1 opens, de-energizing the defrost heater. Contacts N and #4 close, energizing the refrigeration system.

Off Cycle

When the temperature control senses the proper temperature, it opens, shutting off the refrigeration system.

FREEZERS – REMOTE**Cooling Cycle**

With the main ON/OFF switch in the ON position, the current flows, energizing the automatic defrost time clock.

Current also flows through the closed contacts of the temperature control, energizing the liquid line solenoid valve. The increase in suction pressure closes the contacts on the low pressure switch, energizing the refrigeration system.

With contact N closed on the automatic defrost time clock, current flows through the normally open (N.O.) light/fan switch contacts (with the door closed).

When the evaporator coil temperature reaches 30 to 35°F (-1.1 to 1.7°C), the defrost end and fan delay thermostat closes, energizing the evaporator fans.

Defrost Cycle

At preset times on the automatic defrost time clock, the contacts switch to defrost the evaporator. Contact N opens, de-energizing the evaporator fan motor(s). Contact #4 opens, de-energizing the refrigeration system. Contact #1 closes, energizing the evaporator defrost heater.

As the evaporator temperature rises, the defrost end and fan delay thermostat opens to terminate the defrost cycle. Contact #1 opens, de-energizing the defrost heater. Contacts N and #4 close, energizing the refrigeration system.

Off Cycle

When the temperature control senses the proper temperature, it opens, shutting off the liquid line solenoid valve. The drop in suction pressure causes the low pressure switch to open, de-energizing the refrigeration system.

Condensate Water Removal – Refrigerators and Freezers

McCall cabinets are equipped with condensate vaporizer systems.

Remote units use an electrically operated system.

Most self-contained units use energy-saving hot gas supplied by the refrigeration system lines. No drain connection is required.

Defrost Systems

GENERAL

Refrigerator coils are kept below the freezing point (32°F). During compressor “off” time, the evaporator fan continues to circulate 38°F refrigerator compartment air through the evaporator coil. This air circulation raises the coil temperature above the freezing point, melting any frost that may have accumulated.

The run-off water is drained into the vaporizer pan and is evaporated by the hot gas refrigeration line during compressor “on” time.

Freezer coils are defrosted electrically at user-determined times.

NOTE: A freezer’s evaporator fans do not run immediately upon start-up or during and immediately following the defrost cycles. The fans start when the coil reaches a cold temperature. This prevents the fans from blowing heated air on the stored products.

DEFROST SETTINGS

Important

Set the defrost timer to defrost the reach-in during the lowest usage periods.

Each defrost tripper represents 15 minutes of defrost time. At the factory, the timer is set for four automatic defrost cycles daily at 4:00AM, 10:00AM, 4:00PM, and 10:00PM respectively. Each defrost cycle is programmed for 45 minutes duration. Upon start-up, set the clock for the correct time of day by rotating the clock face until the correct time is at the arrow on the face of the timer.

NOTE: If the defrost termination thermostat fails to close, the fail safe setting on the timer will terminate the defrost.

The timer starts the defrost cycle automatically at predetermined times. A setting of two to four defrost cycles per day is typical. For heavier frost loads, additional cycles may be required.

When the defrost cycle begins:

1. Switch 2 to 4 opens in the time clock, breaking the circuit to the room thermostat, liquid line solenoid, and evaporator fan motors. This allows the compressor to pump down and shut off. Simultaneously, switch 1 to 3 closes in the timer, energizing the defrost heaters.
2. The heaters increase the coil temperatures above 32°F, melting the frost off the coil.
3. When the coil warms to approximately 55°F, the defrost termination thermostat closes and energizes the switching solenoid in the timer. At this time, switch 1 to 3 in the timer opens, terminating the defrost heaters. Simultaneously, switch 2 to 4 closes in the time clock, energizing the temperature control circuit.
4. Suction pressure rises, the low pressure control closes, and the compressor starts.
5. The fan relay closes when the coil temperature reaches approximately 30°F. This energizes the fan motors.
6. The system operates in the refrigeration cycle until another defrost cycle is initiated by the timer.

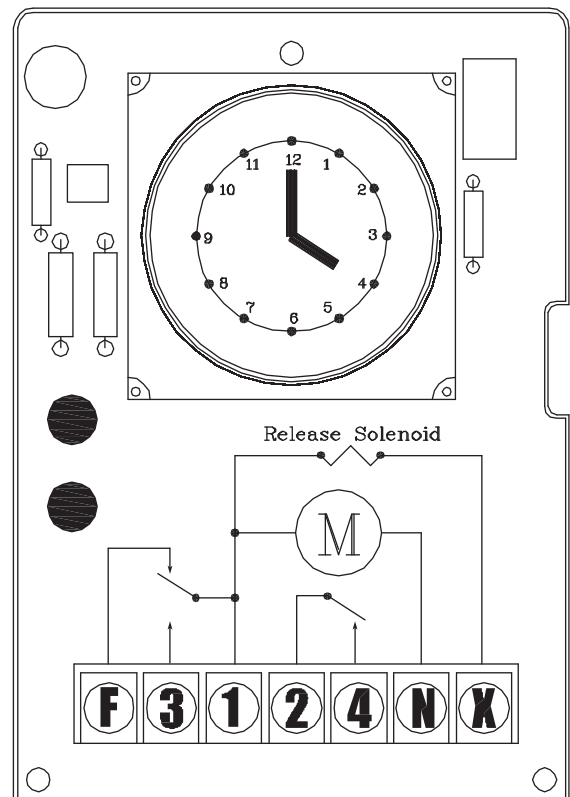

Defrost Timer

Temperature Controls

REFRIGERATORS AND FREEZERS

The temperature controls are factory-set to maintain an average temperature of 38°F in refrigerators, and an average temperature of 0°F in freezers.

The temperature variance is 6-8 degrees. A freezer should run between -2 to -3°F and +3 to +4°F. A refrigerator should run between +35 to +36°F and +41 to +42°F.

For a different cabinet temperature setting, turn the temperature control knob, located behind the front cabinet louver.

Caution

Setting the temperature control to the coldest setting may cause the coil and/or air ducts to freeze and ice up. This will eventually result in a warmer cabinet temperature.

If ice accumulation occurs and the temperature is lower than the guidelines, turn the control knob to a warmer setting.

Caution

Allow the reach-in to reach proper operating temperature before filling it with product. Do not place hot or steaming foods in the cabinet.

REACH-IN HEATED CABINETS

Single-section reach-in heated cabinets are designed to maintain a temperature of up to 170°F. Two-section and three-section cabinets can maintain a temperature of up to 140°F.

The temperature control knob is located on the top front louver. Turn the knob clockwise to raise the temperature, and counterclockwise to lower the temperature.

ROLL-IN HEATED CABINETS

The temperature control panel on a roll-in heated cabinet is located on the front louver panel.

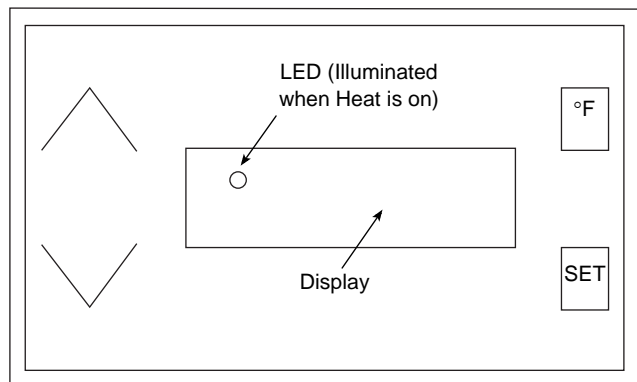

Roll-in Heated Cabinet Control Panel

To adjust the interior cabinet temperature:

1. Make sure that the main power switch (located behind the front louver) and the on/off switch (on the front louver panel) are both ON.
2. Press the SET pad once. "SP1" is displayed.
3. Press the SET pad again to display the numerical set point.
4. To change the temperature, press the up or down arrow.
5. Press the SET pad repeatedly until the display goes blank. After 5 seconds, the screen will display the interior temperature of the cabinet.

NOTE: While the heating element is energized, a small LED light is illuminated between the first 2 digits of the temperature display.

Important

If the programming sequence is interrupted for more than 15 seconds, or not completed through Step 5 (blank screen), the unit will automatically revert to the temperature display mode without accepting the new setting.

Loading Shelves – Reach-in Cabinets

For maximum operating efficiency, load the shelves with space between the stored items. This allows air to circulate properly. Refer to the drawing below.

⚠ Caution
Do not store more than 250 pounds of product on any shelf, and no more than 800 pounds of product per cabinet.

⚠ Caution
Store products with high acid content (such as lettuce, other fresh vegetables or fruits, salad dressings, etc.) in closed containers. This will prevent corrosion on the evaporator coil and other metal parts in the air distribution system.

Important
Uncovered food will dehydrate much more rapidly than covered food. For best food quality, always store in covered container.

⚠ Warning
In a heated cabinet, the shelves, interior cabinet surfaces and food containers are hot. Use care when storing or removing product.

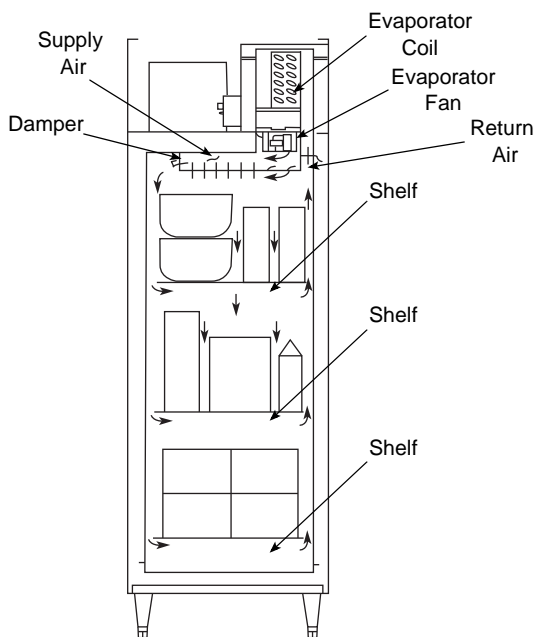

Loading the Shelves

Loading Carts – Roll-in Cabinets

Roll-in cabinets are designed to accept carts of pre-heated food (heated units) or pre-chilled or frozen food (refrigerators or freezers).

Cart guides have been installed in each cabinet bay to keep the cart away from the interior walls. Center the cart(s) in the bay(s) for best air circulation. Refer to the drawing below.

Important
Uncovered food will dehydrate much more rapidly than covered food. For best food quality, always store in covered containers.

⚠ Warning
In a heated cabinet, the cart(s), interior cabinet surfaces and food containers are hot. Use care when storing or removing product.

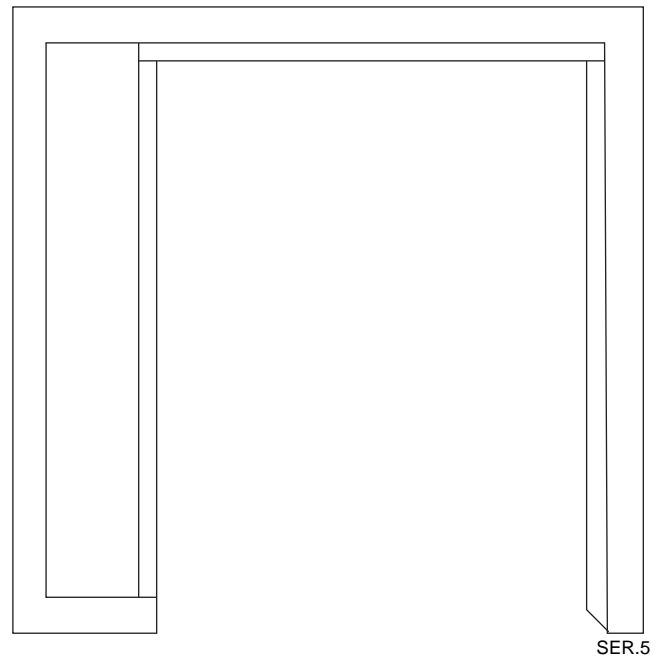

Positioning a Cart in the Cabinet

Adjustments and Calibrations

ADJUSTMENTS

Cabinet doors may require some adjustment after a period of usage, depending upon the frequency of door openings. This is normal. Follow the appropriate procedure below:

Solid Door Adjustment

1. Remove the metal hinge covers that conceal the three hinge mounting screws. Gently pry it off with a flat-bladed screwdriver.

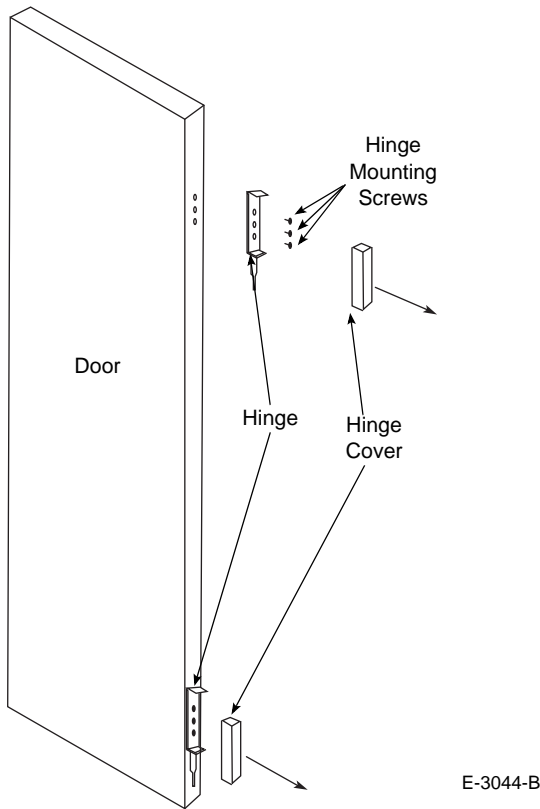

Hinge/Hinge Cover

2. Loosen the three hinge mounting screws approximately two rotations, using a Phillips screwdriver.
3. While a second person firmly pushes the door closed to the front face of the cabinet, re-tighten the screws.
4. Re-install the hinge covers.

Glass Door Adjustment

To adjust the spring tension:

1. Locate the adjustment bushing on the hinges. This bushing is on top of the hinge for right-hand doors and on the bottom for left-hand doors.
2. Insert a small nail (1/8") into a hole in the adjustment bushing. Wind the bushing clockwise until the pin can be removed from the bushing.

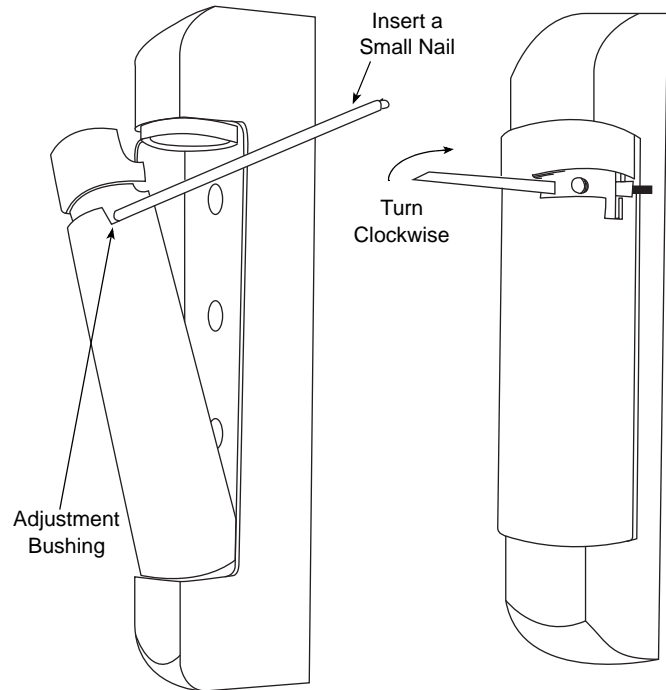

Hinge Adjustment

3. Continue winding the bushing clockwise until the desired tension is achieved.
4. Re-insert the bushing pin.

⚠ Caution

Do not over-tighten the hinge spring.
McCall recommends adjusting the hinge adjustment bushings one hole at a time.

CALIBRATIONS

Occasionally, the rigors of shipping and installation can shift the thermometer out of proper adjustment.

If the accuracy of the thermometer is in question, place another thermometer inside the cabinet at approximately mid-height and compare the readings.

If the thermometer requires adjustment, follow the appropriate procedure below.

Digital Thermometer Calibration

1. Lift up on the front cabinet louver about 5/8" to 1" (16 to 25 mm) to disengage the keyhole slots from the four screws in the cabinet front. Remove the louver.

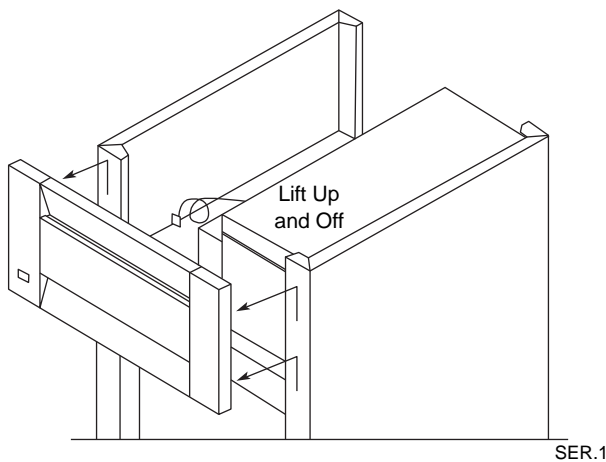

Removing the Front Cabinet Louver

2. Cut the plastic tie holding the thermometer probe wire, taking care not to cut the wire. This releases the full length of the probe wire, allowing the louver to be lowered to the floor.

Important

Do not disconnect the probe wire from the rear of the thermometer display.

3. Locate the two dip switches on the thermometer rear. Set both switches to ON.
4. Locate the blue calibration screw in the upper right corner of the thermometer. Turn the screw clockwise to increase the temperature reading or counterclockwise to decrease the reading.

Caution

Do not apply extreme pressure to the adjustment screw. Damage to the digital display may result.

5. Reset the two dip switches to their original position.
6. Re-install the front louver to the cabinet. Position the keyhole slots in the louver rear on the four screws in the cabinet front. Push it straight down until the louver locks into place.
7. Re-tie or tape the excess length of probe lead wire.

Dial Thermometer Calibration

1. Gently pry off the clear thermometer cover lens with a small flat-bladed screwdriver.
2. While carefully holding the dial indicator needle with one hand, turn the slotted center pivot with a flat-bladed screwdriver. Turn clockwise to decrease the reading and counterclockwise to increase the reading.
3. Replace the clear thermometer cover lens by pressing it into place around the perimeter.

THIS PAGE INTENTIONALLY LEFT BLANK

Section 4

Maintenance

Cleaning Recommendations

EXTERIOR

Clean cabinet exterior surfaces with a solution of mild soap and water. To minimize streaking, follow with a fresh water rinse.

If stainless steel becomes discolored, scrub only in the direction of the finished grain.

For high shine, see your kitchen equipment dealer for a high-quality stainless steel polish.

 **Caution**

Do not use steel wool, caustic soap, or abrasive cleaners, as these may damage the metal finish. Alcohol-based cleaners may damage the nylon door cams.

INTERIOR

Clean cabinet interior surfaces with warm water and baking soda, applied with a cloth or sponge.

The air duct and shelf support standards can be removed without special tools to facilitate cleaning.

Wash door gaskets weekly with a mild soap and water solution, followed by a fresh water rinse.

While cleaning, check the door gaskets for proper sealing. Adjust if needed.

 **Caution**

Never use cleaners that are not approved for use where food may come into contact with cabinet interior surfaces.

 **Caution**

Do not use steel wool, caustic soap, or abrasive cleaners, as these may damage the metal finish.

Cleaning the Condenser Coil – Refrigerators and Freezers

Warning

Disconnect electric power before cleaning.

For efficient operation, it is very important to clean the condenser coil surface and keep it free of dust, dirt, and lint. McCall recommends checking the condition of the condenser coil once a month.

The condensing unit fan draws dust, lint and small particles to the condenser coil, where it forms a “blanket” on the coil surface. This is normal and should be periodically removed.

Caution

Failure to clean and maintain the condenser coil properly will result in reduced air circulation through the condenser fins. This will cause reduced efficiency, high operating pressures, and possible shortened compressor life.

CONDENSER CLEANING PROCEDURES

One or more of the following methods may be used to clean the condenser coil surface, depending upon the extent of the build-up on the fins.

Warning

Condenser fins are sharp. Use care when working around them.

Method 1

Remove light build-up with a soft brush or a vacuum with a brush attachment. Brush the condenser fins from top to bottom, not from side to side. Shine a light through the fins to check for dirt inside the condenser.

Method 2

Clean moderately dirty fins with compressed air, blowing from the inside out. Follow by brushing, if necessary.

Method 3

Clean with a commercial condenser coil cleaner, available from a kitchen equipment dealer. Follow the directions and precautions supplied with the cleaner.

After cleaning, straighten any bent condenser fins with a fin comb.

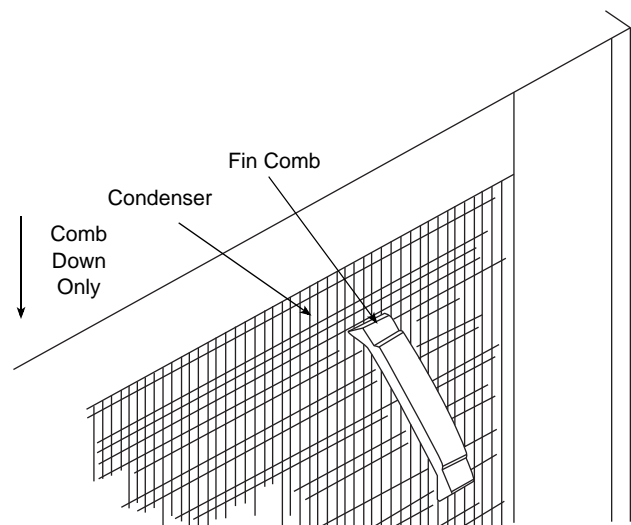

Using a Fin Comb

CLEANING THE FAN BLADES AND MOTOR

If necessary, clean the fan blades and motor with a soft cloth. If it is necessary to wash the fan blades, cover the fan motor to prevent moisture damage.

Component Replacement Procedures

Warning

Disconnect electric power before performing any service.

EVAPORATOR FAN MOTOR – 1 SECTION REFRIGERATORS AND FREEZERS

If Mounting Bracket Is Not Broken

1. Remove *Windrunner* air distribution duct from the cabinet interior ceiling.



2. Disconnect the (2) terminal connectors from the motor.



3. Using a 1/4" nut driver, remove the (2) motor mounting screws and separate the motor from the bracket.

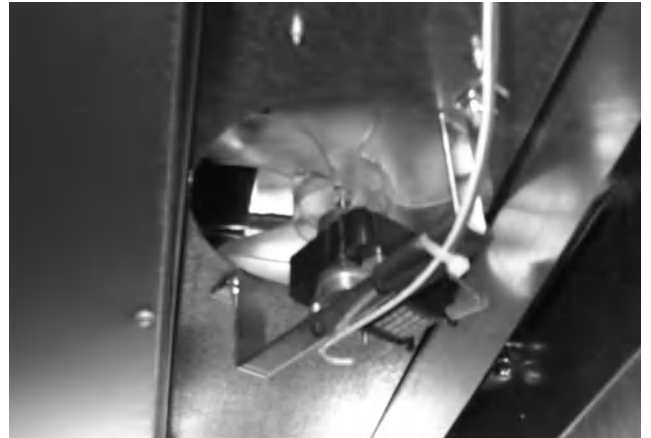

4. Reverse steps 1-3 to replace motor.
5. Reconnect power and return to normal use.

NOTE: The evaporator-housing lid may be removed to provide added lighting and visibility.

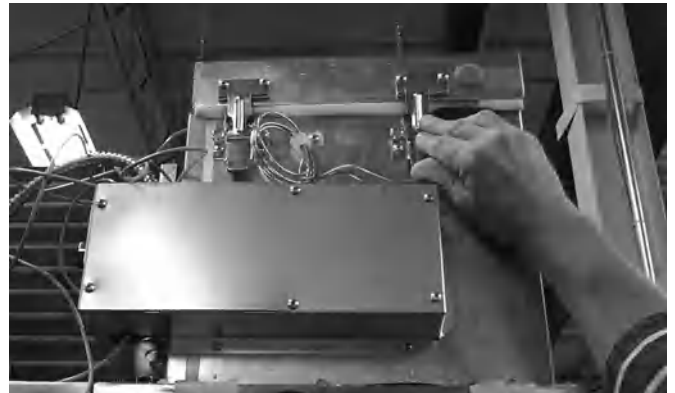

If Mounting Bracket Is Broken

1. Remove the *Windrunner* air distribution duct from the interior ceiling.



2. Disconnect the (2) terminal connectors from the motor.

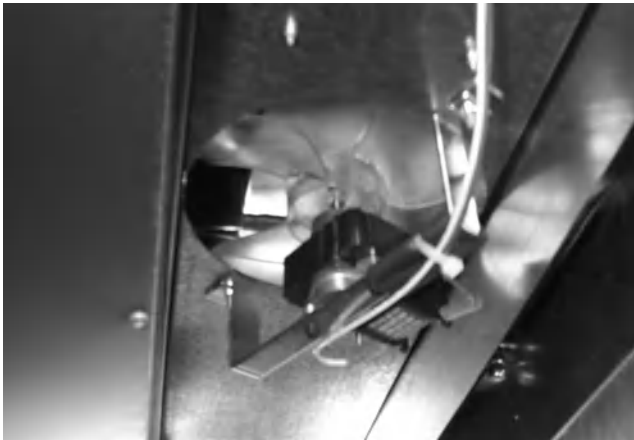

3. Using a 1/4" nut driver, remove the (2) motor mounting screws and separate the motor from the bracket.

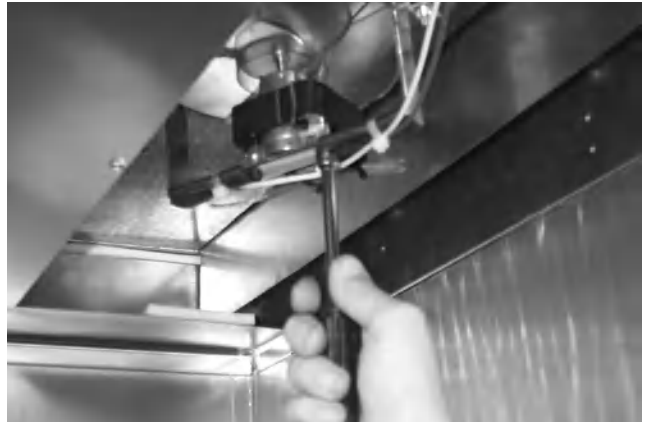

4. Remove the evaporator-housing lid, located on the cabinet top.

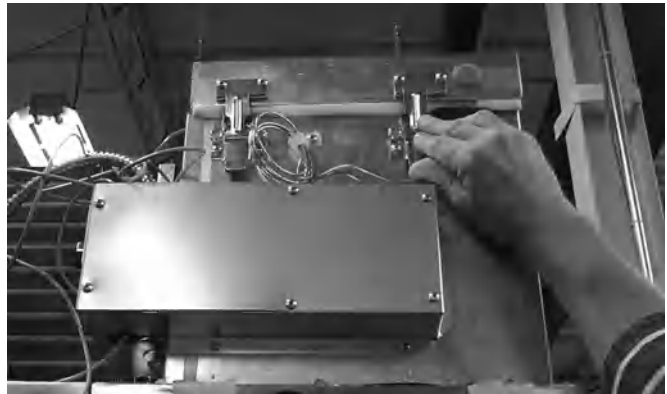

5. Remove the coil mounting screws and carefully lift the coil, only enough to gain access to the motor mounting screws.

Continued on next page ...



6. When the coil has been moved, remove the evaporator drain pan by removing (4)-mounting screws.
7. Remove the bracket mounting screws and replace bracket-motor assembly.
8. Reverse steps 1-5 to complete motor installation.
9. Reconnect power and return to normal use.

LIGHT SWITCH

1. Remove the door by lifting straight up. Carefully set the door aside.



2. Pry off the TOP hinge cover on the cabinet hinge flange with a flat blade screwdriver or flat scraper.



3. Remove the (3) hinge mounting screws and carefully pull the hinge flange from the cabinet front.
4. Slide the light switch and switch retainer from the hinge. Unplug the switch.



5. Install the new switch into the hinge and replace the door hinge onto the cabinet front. Install the (3) mounting screws. Snug the screws but DO NOT tighten fully.
6. Re-hang the door onto the hinges.
7. Make sure that the door is hanging plumb and that the door operates properly.
8. Tighten the screws and replace the hinge cover.

EVAPORATOR FAN MOTOR – 2 AND 3 SECTION REFRIGERATORS AND FREEZERS

1. Remove the evaporator-housing lid, located on the cabinet top, exposing the evaporator fan motor.



2. Remove the wiring box cover. Locate and disconnect the fan motor wires.

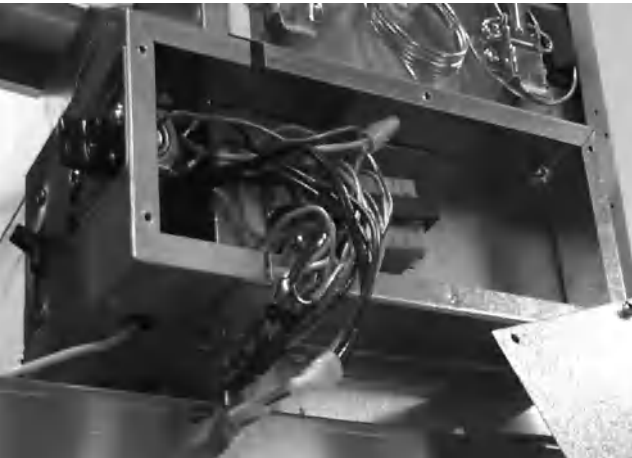

3. Remove the fan bracket mounting screws. Disconnect the wiring terminals from the motor. Remove the defective motor and replace with the new motor. Replace screws.



4. Reconnect motor wires in wiring box. Check to make sure that wire access hole through the evaporator box is properly sealed and reseal if necessary.
5. Replace wiring box cover.
6. Replace the evaporator-housing lid.
7. Reconnect power and return to normal use.

TEMPERATURE CONTROL – REFRIGERATORS & FREEZERS

1. Remove the front louvered hatch cover by lifting straight up and pulling straight out.



2. Lay the hatch cover on top of the freezer evaporator housing.

Important

Do not disconnect the wires to the digital thermometer display.

3. Remove the (6) screws from the thermostat/wiring box front.

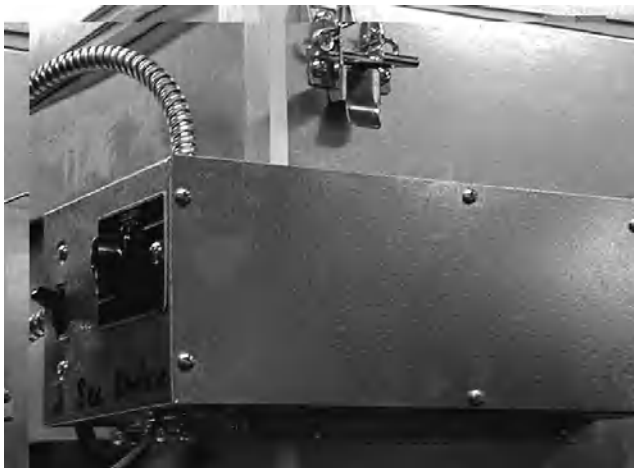

4. Remove the (2) mounting screws and the control knob from the face of the control.
5. Remove the lid from the evaporator housing by unlocking the (4) hold-down latches.



6. Remove the temperature control sensor from the aluminum sleeve by pulling out slowly. Remove the sensor from the evaporator housing.

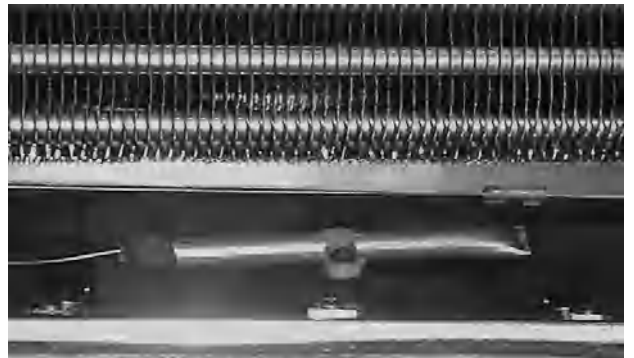

7. Replace the temperature control and install sensor.
8. Reset the temperature to setting #4 to #5 on refrigerators and #5 to #6 on freezers.
9. Monitor temperature for final control adjustments.

TEMPERATURE CONTROL – HEATED HOLDING CABINETS

Dial Type

1. Turn off the main power to the cabinet.
2. Loosen the control box by removing the two screws on the front louvered hatch cover.

NOTE: Control may be accessed easier from the cabinet rear.

3. Remove the temperature control knob and take out the two mounting screws.
4. Disconnect the wire leads to the temperature control.
5. Reverse steps 1-4 to install the new control.

Digital Type

1. Turn off the main power to the cabinet.
2. Remove the front louvered hatch cover by lifting up and pulling straight out.
3. Remove the 2 mounting screws that secure the temperature control box to the front louvered hatch cover.
4. Disconnect the wires from the back of the digital control box.
5. Press the locking tabs inward on the control box and slide it out of the louvered hatch cover.
6. Reverse steps 1-5 to replace the control, (refer to the diagram below for correct wiring).

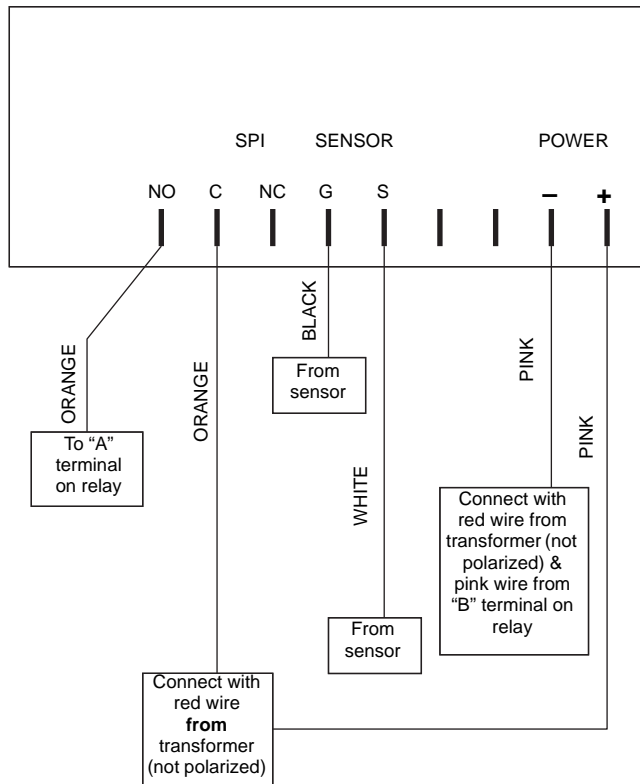

Digital Controller – Back View

DEFROST HEATER ELEMENT

1. Remove the front lowered hatch cover by lifting up and pulling straight out.



2. Remove lid of evaporator housing, located on top of unit.

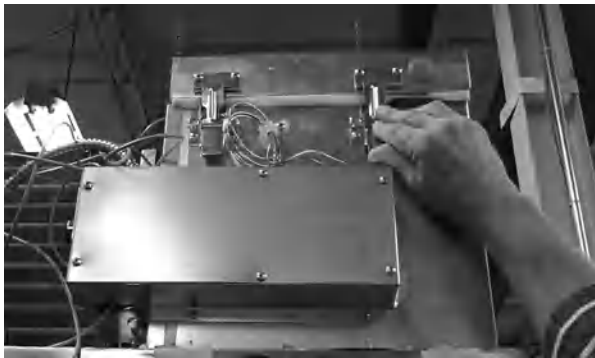

3. Remove coil mounting screws and lift coil up slowly, exposing coil heater.



4. Disconnect coil heater wiring (see the following figure for 1-section cabinets and the figure on the next page for 2 and 3 section cabinets) and simply pull heater from coil mounting area.



Continued on next page ...



5. Install new heater by gently tapping heater back into the mounting area by using a rubber mallet or similar object.



6. Reconnect wiring and reposition evaporator coil.
7. Secure coil with mounting screws.
8. Reposition evaporator cover lid and lock down latches.
9. Reattach the louvered hatch cover, making sure that the thermometer connections are firmly engaged.
10. Return to normal use.

EVAPORATOR DRAIN PAN HEATER ELEMENT**⚠ Warning**

Disconnect the electric power to the freezer before proceeding with the following steps.

1. Remove front louvered hatch cover by lifting up and pulling straight out.



2. Remove the evaporator box cover lid.

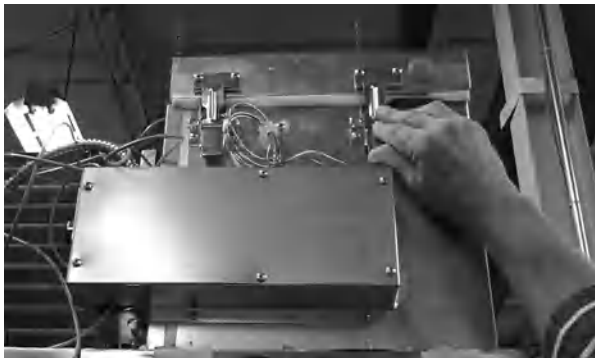

3. Remove coil mounting screws and lift coil up slowly, not to detach lines or wiring.



4. Disconnect the heater wires located in the wiring box for 2 and 3 section cabinets or wiring bundle for 1 section cabinets.



Continued on next page ...

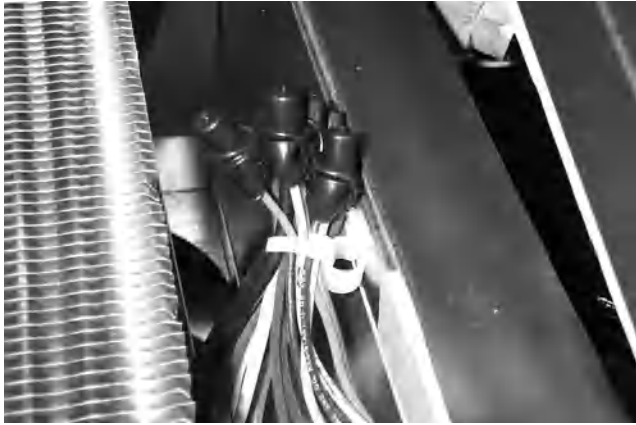

5. Replace drain pan heater and reconnect wiring.
6. Reposition evaporator coil and secure with mounting screws.
7. Reposition the evaporator housing cover and lock down latches.
8. Attach front louvered hatch cove, making sure that the thermometer connections are fully engaged.
9. Return to normal use.

HEATER ELEMENT – HEATED HOLDING CABINETS

1. Turn off the main power to the cabinet.
2. Remove the right side blower panel by removing the (13) screws.

NOTE: Blower motor wiring may be disconnected to allow easier blower panel removal.

3. Disconnect the wiring leads to the element by loosening the nuts with a small wrench.
4. Replace the heater element.
5. Reverse steps 1-3 to re-install the wiring and blower panel.

THERMAL LIMIT SWITCH – HEATED HOLDING CABINETS

1. Turn off the main power to the cabinet.
2. Remove the right side blower panel by removing the (13) screws.

NOTE: Blower motor wiring may be disconnected to allow easier blower panel removal.

3. Disconnect the wiring leads to the limit switch.
4. Drill out the (2) rivets holding the switch in place.
5. Replace the limit switch and secure with rivets or screws.
6. Reverse steps 1-3 to re-install the wiring and blower panel.

BLOWER FANS – HEATED HOLDING CABINETS

1. Turn off the main power to the cabinet.
2. Remove the right side blower panel by removing the (13) screws.

NOTE: Blower motor wiring may be disconnected to allow easier blower panel removal.

3. Disconnect the fan motor lead wires and replace motor.
4. Reverse steps 1-2 to re-install the wiring and blower panel.

DIGITAL THERMOMETER DISPLAY AND PROBE

1. Remove the front louvered hatch cover by lifting straight up and pulling straight out.



2. Unplug the thermometer probe from the back of the digital display module.
3. Unscrew from bracket the display module from the hatch cover back with a flat blade screwdriver or scraping tool.



4. Disconnect the (2) yellow wires from the probe harness. Remove the probe from the interior ceiling by loosening the mounting bracket screw.



5. Remove the Permagum sealant from the cabinet top where the probe wire penetrates the top. Carefully pull the probe wire through the cabinet top.
6. Feed the new probe wire through the top hole and reattach the probe and bracket to the interior ceiling.
7. Carefully, pull the wire taught and reseal the cabinet top hole with the Permagum.

Continued on next page ...

8. Carefully align the module with the rectangle cutout in the hatch cover.



9. Plug the probe wire terminal onto the back of the display module, making sure that the plug lines up with the pins on the module.



10. Reconnect the (2) yellow wires from the transformer with the gray leads on the probe.
11. Reinstall the hatch cover and secure any excess wire with a wire tie.
12. Check operation and return to normal service.

DIGITAL THERMOMETER TRANSFORMER**Warning**

Disconnect the electric power to the freezer before proceeding with the following steps.

1. Remove the front louvered hatch cover by lifting straight up and pulling straight out.



2. Remove the (6) screws from the wiring box front.

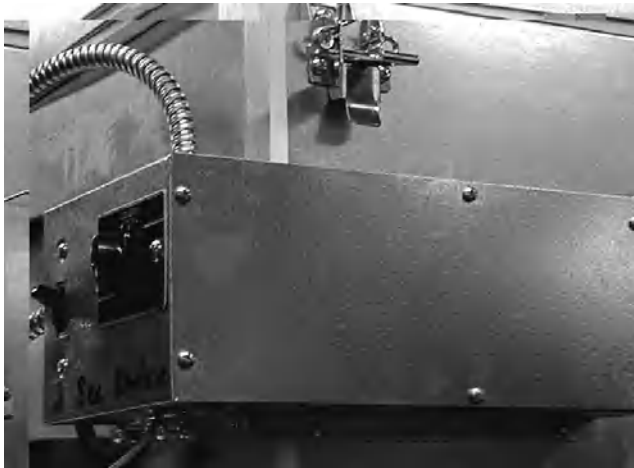

3. Disconnect the black and white wires on the transformer from the power and neutral wires in the wiring box.
4. Disconnect the yellow wires on the transformer from the (2) gray wires on the transformer probe.

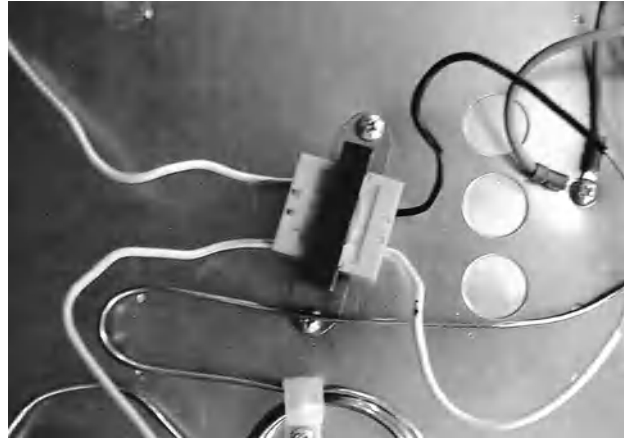

5. Remove the transformer from the evaporator housing and replace with the new transformer.
6. Reconnect all wiring.
7. Replace the top louvered hatch cover.
8. Power up the freezer.
9. Return to normal operation.

DOOR HANDLE – SOLID DOORS

1. Remove the foot from the door lock assembly.



3. Remove out the two mounting screws and remove the door handle.

2. Pry off gray plug button (located in the rear center of the door) and a small section of the door gasket nearest the lock assembly (see the next two figures).



4. Reverse steps 1-3 to install the new door handle.

DOOR HANDLE – GLASS DOORS

1. Pry or lift off a small section of door gasket behind the door handle, exposing the (2) handle mounting screws.



2. Remove the two mounting screws to release the handle.
3. Replace door handle.
4. You may need a rubber mallet to re-install gasket.

DOOR HINGE – SOLID DOORS

1. Remove the door by lifting straight up. Carefully set the door aside.



2. Pry off the hinge cover with a thin flat blade screwdriver.



Continued on next page ...

3. Remove the (3) three hinge mounting screws from each hinge on the cabinet front. Replace the hinge and reattach with the screws.

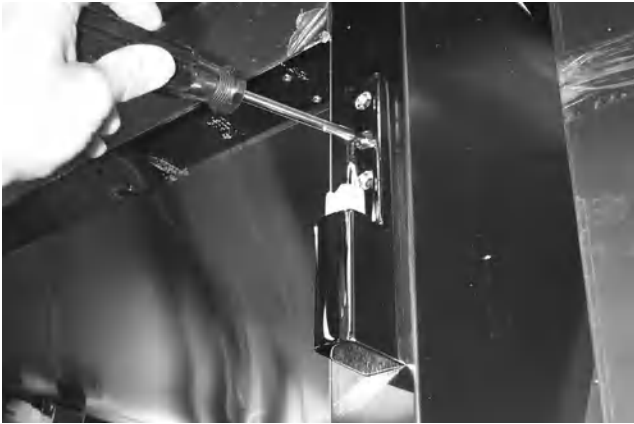

4. Remove the (3) three hinged mounting screws from each flange on the door and replace hinge.



5. Install the door and check operation.

DOOR GASKET – SOLID DOORS

1. Remove the old gasket by pulling the gasket from the foamed in retainer in the door.



2. Starting the upper left corner of the door, place the locking male lip into the retainer of the door.
3. Firmly press into place until the gasket locks.
4. If necessary, gently tap into place with a rubber mallet.

DOOR GASKET – GLASS DOORS

1. Remove the old gasket by pulling the gasket from the foamed in retainer in the door.



2. Starting the upper left corner of the door, place the locking male lip into the retainer of the door.
3. Firmly press into place until the gasket locks.
4. If necessary, gently tap into place with a rubber mallet.

DOOR LOCK – SOLID DOORS

1. Remove latch on lock assembly.
2. Remove the (2) two handle mounting screws and carefully pull handle off the door. Refer to door handle replacement procedures for handle removal procedures.
3. Remove the remainder of the lock assembly and replace.
4. Check operation.

VINYL BREAKER STRIPS – DOOR JAMBS

Warning

Disconnect the electric power to the freezer before proceeding with the following steps.

1. Remove the flat vinyl breakers by gently prying off with a flat-blade screwdriver.

Warning

Door heater wires lie directly behind the front edge of the flat breaker strips. Take care not to damage the wires.

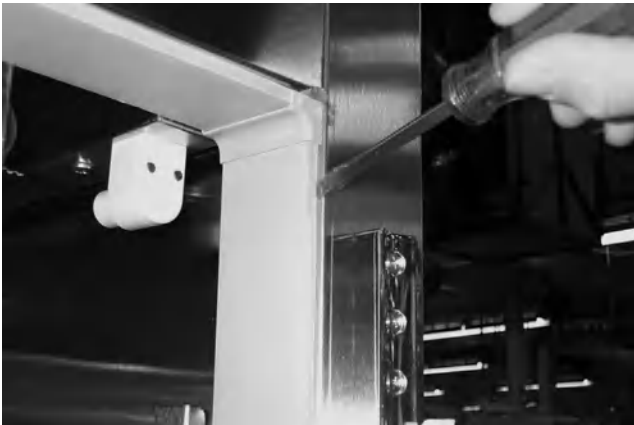

2. Remove the corner blocks as necessary by slipping the male tab from the flat breaker.

3. Replace the breakers by starting each end into the corner blocks and snapping into place.
4. Gently tap the breaker into place if necessary, using a rubber mallet.



ANTI-CONDENSATE DOOR HEATER WIRES

Warning

Disconnect the electric power to the freezer before proceeding with the following steps.

1. Remove the vinyl door breakers as described previously.
2. Carefully, pull the heater wire connections from the inside top corner.
3. Clip the connections, making sure to leave enough wire length to reconnect the new heater wire.

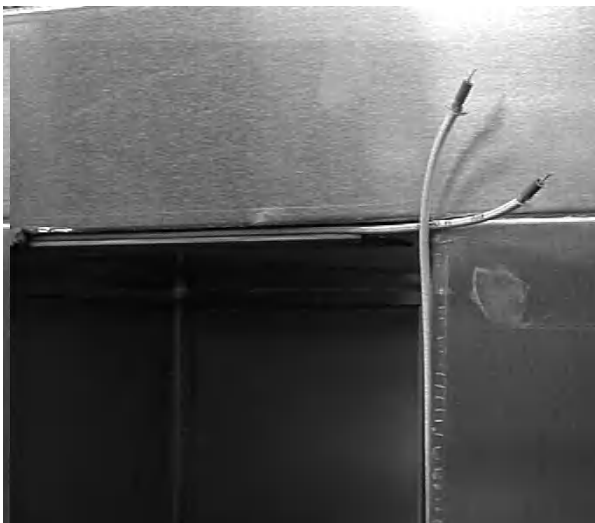

4. Remove the old heater wire.
5. Starting at the inside corner, carefully place the new heater wire around the door perimeter, fitting it into the space between the primary breaker retainer and the metal cabinet face.
6. Connect each end of the heater wire to the leads in the corner.
7. Replace the breaker strips as described previously.

DEFROST TERMINATION/FAN DELAY SWITCH

Warning

Disconnect the electric power to the freezer before proceeding with the following steps.

1. Remove the evaporator-housing lid.



2. Locate the 3-wire defrost termination/fan delay switch, clamped to the suction line.

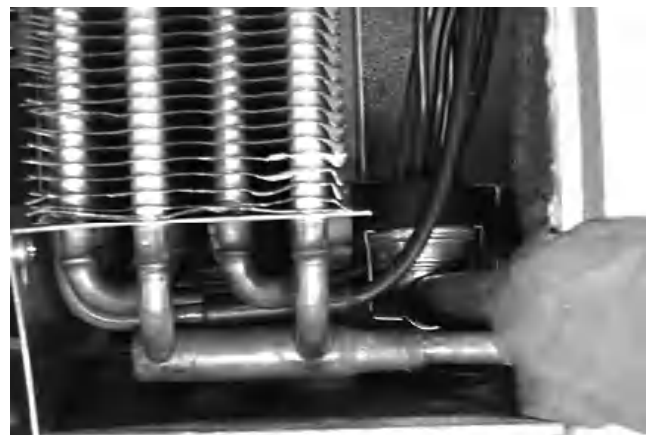

Continued on next page ...

3. Remove the wiring box cover on the front of the evaporator housing on 2 and 3 section cabinets. Wiring connections for 1 section cabinets are located inside evaporator housing.



4. Trace and disconnect the defrost termination/fan delay switch from the wiring bundle. Re-connect the new switch.
5. Attach the new switch to the suction line.
6. Replace the evaporator-housing lid.
7. Connect the power and resume normal operation.

NOTE: The evaporator fan will not restart until the fan delay switch senses 32°F from the suction line.

Section 5

Before Calling for Service

Checklist

If a problem arises during operation of your cabinet, follow the checklist below before calling service. Routine adjustments and maintenance procedures are not covered by the warranty.

 **Warning**

Disconnect electric power before performing any service.

Problem	Possible Cause	To Correct
Cabinet not running	Fuse blown or circuit breaker tripped.	Replace fuse or reset circuit breaker.
	Power cord unplugged.	Plug in power cord.
	Thermostat set too high.	Set thermostat to lower temperature.
	Main power switch turned off.	Turn main power switch on.
	Cabinet in defrost cycle. (Freezer models)	Wait for defrost cycle to finish.
Condensing unit runs for long periods or continuously (Refrigerator or Freezer)	Excessive amount of warm product placed in cabinet.	Allow adequate time for product to cool down.
	Prolonged door openings or door(s) ajar.	Make sure door(s) are closed when not in use. Avoid prolonged door openings.
	Door gasket(s) not sealing properly.	Check gasket condition. Adjust door or replace gasket if necessary.
	Dirty condenser coil.	Clean the condenser coil.
	Evaporator coil iced over.	Turn unit off and allow coil to defrost. Make sure thermostat is not set too cold. Also, check gasket condition.
Cabinet temperature is too high (Refrigerator or Freezer)	Thermostat set too high.	Set thermostat to lower temperature.
	Poor air circulation in cabinet.	Re-arrange product to allow proper air circulation.
	Exterior thermometer is out of calibration.	Re-calibrate thermometer.
	Excessive amount of warm product placed in cabinet.	Allow adequate time for product to cool down.
	Prolonged door openings or door(s) ajar.	Make sure door(s) are closed when not in use. Avoid prolonged door openings.
	Dirty condenser coil.	Clean the condenser coil.
	Evaporator coil iced over.	Turn unit off and allow coil to defrost. Make sure thermostat is not set too cold. Also, check gasket condition.
Cabinet is noisy	Loose part(s).	Locate and tighten loose part(s).
	Tubing vibration.	Ensure tubing is free from contact with other tubing or components.
Refrigerator is freezing product	Thermostat is set too low.	Set thermostat to higher temperature.
Compressor will not start — hums and trips on overload protector (Refrigerator or Freezer)	Dirty condenser coil.	Clean the condenser coil.
	Not enough cabinet clearance for proper refrigeration system operation.	Move cabinet or make other adjustments to gain proper cabinet clearances.
	Low voltage to cabinet.	Check and correct incoming voltage to cabinet.
Cabinet temperature too low (Heated Cabinet)	Fuse blown or circuit breaker tripped.	Replace fuse or reset circuit breaker.
	Both power switches not on.	Turn on power switches.
	Control temperature set incorrectly.	Refer to page 3-4 for temperature setting procedure.

Problem	Possible Cause	To Correct
Cabinet control will not change cabinet temperature (Heated Cabinet)	Fuse blown or circuit breaker tripped.	Replace fuse or reset circuit breaker.
	Both power switches not on.	Turn on power switches.
	Control temperature set incorrectly.	Refer to page 3-4 for temperature setting procedure.
Digital thermometer blank or displaying incorrect temperature	Fuse blown or circuit breaker tripped.	Replace fuse or reset circuit breaker.
	Main power switch turned off.	Turn main power switch on.
	Thermometer probe wire disconnected at thermometer back.	Connect thermometer probe wire.
	Display module requires calibration.	Refer to page 3-7 for calibration procedure.
Digital thermometer displaying "LLL" or "HHH"	Display module requires calibration.	Refer to page 3-7 for calibration procedure.

EVAPORATOR CHECKLIST

Problem	Possible Cause	To Correct
Fan(s) will not operate	Main switch open.	Close switch.
	Blown fuse.	Replace fuse(s). Check for short circuits or overload conditions.
	Defective motor.	Replace motor.
	Defective timer or defrost thermostat.	Replace defective component.
	Unit in defrost cycle.	Wait for completion of cycle.
Cabinet temperature too high	Thermostat set too high.	Adjust thermostat.
	Superheat too high.	Adjust thermal expansion valve.
	System low on refrigerant.	Locate and repair leak, recover, evacuate and recharge.
	Coil iced up.	Manually defrost coil. Check defrost controls.
Ice accumulating on ceiling around evaporator and/or on fan guards, venturi, or blades	Defrost duration is too long.	Adjust defrost termination thermostat (if available).
	Fan delay not delaying fans after defrost period.	Replace defective defrost thermostat.
	Defective defrost thermostat or timer.	Replace defective component.
	Too many defrost cycles per day.	Reduce number of defrost cycles per day.
Frost on coil after defrost	Coil temperature not getting heated.	Check heater operation.

EC DECLARATION OF CONFORMITY

We hereby declare that our products, ice machines and Multiplex refrigeration equipment comply with all the essential requirements of the listed EC - directives.

Manufacturer:

Manitowoc Ice, Inc.
2110 S. 26th Street, P.O. Box 1720
Manitowoc, Wisconsin 54221-1720 USA

European Distributor:

Representative of Manitowoc Ice, Inc.:

Engineering Manager, (Printed name)

Representative of European Distributor:

Signature

Model and Serial No.

Applied EC Directives:

Applied Standards:

EN60335-1 Safety of household and similar electrical appliances
EN60335-2-24 Particular requirements refrigerators, food freezers and ice makers

EN55014 Electrical Motor Operated Appliances (Emissions)
EN55014 Electro Magnetic Compatibility (Immunity)
EN137B -1 to -4 Refrigeration Plants

Low Voltage 73/23/EEC
EMC 89/336/EEC
Pressure Equipment 97/23/EC



8201043
08/25/03



© 2008 Manitowoc
Continuing product improvements
may necessitate change of
specifications without notice.
Part Number 14479 2/08



McCall

McCall Refrigeration, Inc.
81 West Holly Street
Parsons, TN 38363, USA
Ph: 731-847-5365 Fax: 731-847-9012
Visit us online at: www.manitowocfsg.com

