



# Concepts Serving Systems

## Use & Care Manual

Please read this manual completely before attempting to install or operate this equipment!  
Notify carrier of damage! Inspect all components immediately.



**Important Information**  
**Read Before Use**  
**Please Save These Instructions!**

## Important Warning And Safety Information



WARNING

Read This Manual Thoroughly Before Operating, Installing, Or Performing Maintenance On The Equipment.



WARNING

Failure To Follow Instructions In This Manual Can Cause Property Damage, Injury Or Death.



WARNING

Do Not Store Or Use Gasoline Or Other Flammable Vapors Or Liquids In The Vicinity Of This Or Any Other Appliance.



WARNING

Unless All Cover And Access Panels Are In Place And Properly Secured, Do Not Operate This Equipment.



WARNING

This Appliance Is Not Intended For Use By Persons Who Lack Experience Or Knowledge, Unless They Have Been Given Supervision Or Instruction Concerning Use Of The Appliance By A Person Responsible For Their Safety.



WARNING

This Appliance Is Not To Be Played With.



WARNING

Do Not Clean With Water Jet.



WARNING

Do Not Use Electrical Appliances Inside The Food Storage Compartment Of This Appliance.



CAUTION

Observe the following:

- Minimum clearances must be maintained from all walls and combustible materials.
- Keep the equipment area free and clear of combustible material.
- Allow adequate clearance for air openings.
- Operate equipment only on the type of electricity indicated on the specification plate.
- Unplug the unit before making any repairs.
- Retain this manual for future reference.

## Contents

Receiving & Inspecting The Equipment .....	3
Serial Number Location.....	4
Warranty Information .....	4
Regulatory Certifications .....	4
Specifications.....	5-9
Operation	
Heated Units .....	10
Mechanically Cooled Serving Counters.....	10
LiquiTec Units.....	11
Frost Top Serving Counters.....	11
Mobile Hand Sink.....	12
Tower Module.....	12
Maintenance .....	13
Wiring Diagrams	
Heated Serving Counter .....	14
Mechanically Cooled Serving Counter.....	15
LiquiTec Units.....	15
Frost Top Serving Counters.....	15
Tower Module.....	16
Mobile Hand Sink.....	16
Replacement Parts List.....	17-19
Standard Labor Guidelines .....	20
Notes.....	21-23

## Receiving And Inspecting The Equipment

Even though most equipment is shipped crated, care should be taken during unloading so the equipment is not damaged while being moved into the building.

1. Visually inspect the exterior of the package and skid or container. Any damage should be noted and reported to the delivering carrier immediately.
2. If damaged, open and inspect the contents with the carrier.
3. In the event that the exterior is not damaged, yet upon opening, there is concealed damage to the equipment notify the carrier. Notification should be made verbally as well as in written form.
4. Request an inspection by the shipping company of the damaged equipment. This should be done within 10 days from receipt of the equipment.
5. Check the lower portion of the unit to be sure legs or casters are not bent.
6. Also open the compressor compartment housing and visually inspect the refrigeration package. Be sure lines are secure and

base is still intact.

7. Freight carriers can supply the necessary damage forms upon request.
8. Retain all crating material until an inspection has been made or waived.



The units with LiquiTec technology cold pans contain a non-toxic eutectic fluid within a sealed inner liner. This fluid may leak if the tank is punctured so care must be taken when uncrating and setting in place. The eutectic fluid is non-toxic and may be flushed down a disposal drain. If the LiquiTec unit cold pans leak, immediately call the Delfield service department directly at 1-800-733-8821 not your local service agent.

### Uncrating the Equipment

First cut and remove the banding from around the crate. Remove the front of the crate material, use of some tools will be required. If the unit is on legs remove the top of the crate as well and lift the unit off the skid. If the unit is on casters it can be "rolled" off the skid.

## Serial Number Information

If your unit is **heated**, the serial tag is located above the louvered panel near the on/off switch.

**Refrigerated** units have the serial tag located in the compressor area near the on/off switch.

**Understorage** units often have the serial tag located on the left inside the storage area.

**All purpose counters, utility equipment or delivery carts** do not require serial numbers but a model tag is placed at the top of the pylon on the back of the unit.

**Always have the serial number of your unit available when calling for parts or service.**

This manual covers standard units only. If you have a custom unit, consult the customer service department at the number listed below.

©2013 The Delfield Company. All rights reserved. Reproduction without written permission is prohibited.

"Delfield" is a registered trademarks of The Delfield Company.

## Warranty Information

Visit [http://www.delfield.com/minisite/service/warranty\\_info](http://www.delfield.com/minisite/service/warranty_info) to:

- Register your product for warranty.
- Verify warranty information.
- View and download a copy of your warranty.

## Regulatory Certifications

All Models are certified by:



Electical models are also certified by:



# Specifications

This manual covers standard units only. If you have a custom unit, consult the customer service department at the number listed below.

Cashier Counter				
Model	Length	Width	Height	Ship Weight
DCCS-SD	45.00"	36.00"	36.00"	270lbs/122kg
DCCS-SDW	45.00"	54.00"	36.00"	320lbs/145kg
DCCS-SDWL	45.00"	54.00"	36.00"	295lbs/134kg
DCCS-SDWR	45.00"	54.00"	36.00"	295lbs/134kg
DCCS-DD	72.00"	36.00"	36.00"	540lbs/245kg
DCCS-DDW	72.00"	54.00"	36.00"	590lbs/268kg
DCCS-DDWL	72.00"	54.00"	36.00"	565lbs/256kg
DCCS-DDWR	72.00"	54.00"	36.00"	565lbs/256kg

FlexiShield™ Food Shields Radial Glass Front, Single Tier with Glass Shelf, Single Service, Inside & Outside										
Model	L	W	H	Ship Weight	Model	L	W	H	Ship Weight	
DCFSRIG-2	38.47"	18.00"	18.00"	Contact Factory	DCFSROG-2	43.09"	18.00"	18.00"	Contact Factory	
DCFSRIG-3	53.43"	18.00"	18.00"	Contact Factory	DCFSROG-3	59.85"	18.00"	18.00"	Contact Factory	
DCFSRIG-4	68.17"	18.00"	18.00"	Contact Factory	DCFSROG-4	76.35"	18.00"	18.00"	Contact Factory	
DCFSRIG-5	82.61"	18.00"	18.00"	Contact Factory	DCFSROG-5	92.53"	18.00"	18.00"	Contact Factory	

FlexiShield™ Food Shields Radial Single Tier, Fixed Sneeze Guard Front, Dual Service				
Model	L	W	H	Ship Weight
DCFSRKD-2	40.78"	35.50"	14.75"	Contact Factory
DCFSRKD-3	56.64"	35.50"	14.75"	Contact Factory
DCFSRKD-4	72.26"	35.50"	14.75"	Contact Factory
DCFSRKD-5	87.57"	35.50"	14.75"	Contact Factory

FlexiShield™ Food Shields Radial Single Tier, Fixed Sneeze Guard Front, Single Service, Inside & Outside									
Model	L	W	H	Ship Weight	Model	L	W	H	Ship Weight
DCFSRIKS-2	38.47"	18.00"	14.75"	Contact Factory	DCFSROKS-2	43.09"	18.00"	14.75"	Contact Factory
DCFSRIKS-3	53.43"	18.00"	14.75"	Contact Factory	DCFSROKS-3	59.85"	18.00"	14.75"	Contact Factory
DCFSRIKS-4	68.17"	18.00"	14.75"	Contact Factory	DCFSROKS-4	76.35"	18.00"	14.75"	Contact Factory
DCFSRIKS-5	82.61"	18.00"	14.75"	Contact Factory	DCFSROKS-5	92.53"	18.00"	14.75"	Contact Factory

Utility Serving Counter Specifications									
Model	Length	Depth	Height	Ship Weight	Model	Length	Depth	Height	Ship Weight
DCBU-38	38.00"	36.00"	36.00"	171lbs/78kg	DCBU-T38	38.00"	36.00"	36.00"	171lbs/78kg
DCBU-52	52.00"	36.00"	36.00"	234lbs/106kg	DCBU-T52	52.00"	36.00"	36.00"	234lbs/106kg
DCBU-66	66.00"	36.00"	36.00"	297lbs/135kg	DCBU-T66	66.00"	36.00"	36.00"	297lbs/135kg
DCBU-80	80.00"	36.00"	36.00"	360lbs/163kg	DCBU-T80	80.00"	36.00"	36.00"	360lbs/163kg
DCBU-94	94.00"	36.00"	36.00"	423lbs/192kg	DCBU-T94	94.00"	36.00"	36.00"	423lbs/192kg
DCBU-120	120.00"	36.00"	36.00"	540lbs/245kg	DCBU-T120	120.00"	36.00"	36.00"	540lbs/245kg



## Specifications, continued

Self-Contained Frost Top Serving Counter							
Model	Length	Depth	Height	H.P.	V/Hz/Ph	Amps	Ship Weight
DC-FT2	38.00"	36.00"	36.00"	1/4	115/60/1	7.5	399lbs/181kg
DC-FT3	52.00"	36.00"	36.00"	1/4	115/60/1	7.5	546lbs/248kg
DC-FT4	66.00"	36.00"	36.00"	1/4	115/60/1	7.5	693lbs/314kg
DC-FT5	80.00"	36.00"	36.00"	1/4	115/60/1	7.5	840lbs/381kg
DC-FT6	94.00"	36.00"	36.00"	1/3	115/60/1	8.0	987lbs/448kg

Heated Serving Counter								
Model	Length	Depth	Height	Watts	# of 12x20 Pans Held	V/Hz/Ph	Amps	Ship Weight
DC-H2	38.00"	36.00"	36.00"	2000	2	115/60/1	16.6	228lbs/103kg
DC-H3	52.00"	36.00"	36.00"	3000/4000	3	208-230/60/1	15.0/16.0	312lbs/142kg
DC-H4	66.00"	36.00"	36.00"	4000/4800	4	208-230/60/1	20.0/22.0	396lbs/180kg
DC-H5	80.00"	36.00"	36.00"	5000/6000	5	208-230/60/1	24.0/27.0	480lbs/218kg
DC-H6	94.00"	36.00"	36.00"	6000/7200	6	208-230/60/1	29.0/32.0	564lbs/256kg

Ice Cooled Serving Counter					
Model	Length	Depth	Height	# of 12x20 Pans Held	Ship Weight
DC-IC2	38.00"	36.00"	36.00"	2	209lbs/95kg
DC-IC3	52.00"	36.00"	36.00"	3	286lbs/130kg
DC-IC4	66.00"	36.00"	36.00"	4	363lbs/165kg
DC-IC5	80.00"	36.00"	36.00"	5	440lbs/200kg
DC-IC6	94.00"	36.00"	36.00"	6	517lbs/235kg

Self-Contained LiquiTec® Cold Pan Serving Counter									
Model	Length	Depth	Height	# of 12x20 Pans Held	H.P.	V/Hz/Ph	Amps	BTU	Ship Weight
DC-L2	38.00"	36.00"	36.00"	2	1/4	115/60/1	7.5	379	342lbs/155kg
DC-L3	52.00"	36.00"	36.00"	3	1/4	115/60/1	7.5	569	468lbs/212kg
DC-L4	66.00"	36.00"	36.00"	4	1/4	115/60/1	7.5	758	594lbs/269kg
DC-L5	80.00"	36.00"	36.00"	5	1/4	115/60/1	7.5	948	720lbs/327kg
DC-L6	94.00"	36.00"	36.00"	6	1/4	115/60/1	7.5	1138	846lbs/384kg

Self-Contained Mechanically Cooled Serving Counter									
Model	Length	Depth	Height	# of 12x20 Pans Held	H.P.	V/Hz/Ph	Amps	BTU Load	Ship Weight
DC-MC2	38.00"	36.00"	36.00"	2	1/4	115/60/1	7.5	379	323lbs/147kg
DC-MC3	52.00"	36.00"	36.00"	3	1/4	115/60/1	7.5	569	442lbs/200kg
DC-MC4	66.00"	36.00"	36.00"	4	1/4	115/60/1	7.5	758	561lbs/254kg
DC-MC5	80.00"	36.00"	36.00"	5	1/4	115/60/1	7.5	948	680lbs/308kg
DC-MC6	94.00"	36.00"	36.00"	6	1/3	115/60/1	8.0	1138	799lbs/362kg

## Specifications, continued

Radial Utility Serving Counter				
Model	Length	Depth	Height	Ship Weight
DCRU-O	103.32"	36.00"	36.00"	464lbs/210kg
DCRU-I	103.32"	36.00"	36.00"	464lbs/210kg
DCRU-OT	103.32"	36.00"	36.00"	464lbs/210kg
DCRU-IT	103.32"	36.00"	36.00"	464lbs/210kg

Radial Heated Serving Counter								
Model	Length	Depth	Height	Watts	# of 12x20 Pans Held	V/Hz/Ph	Amps	Ship Weight
DCRU-H225	58.44"	36.00"	36.00"	2000	2	115/60/1	16.6	369lbs/167kg
DCRU-H332	75.55"	36.00"	36.00"	3000/4000	3	208-230/60/1	15.0/16.0	485lbs/220kg
DCRU-H440	92.35"	36.00"	36.00"	4000/4800	4	208-230/60/1	20.0/22.0	601lbs/273kg
DCRU-H2	103.32"	36.00"	36.00"	2000	2	115/60/1	16.6	563lbs/255kg
DCRU-H3	103.32"	36.00"	36.00"	3000/4000	3	208-230/60/1	15.0/16.0	604lbs/274kg
DCRU-H4	103.32"	36.00"	36.00"	4000/4800	4	208-230/60/1	20.0/22.0	645lbs/293kg
DCRU-H5	103.32"	36.00"	36.00"	5000/6000	5	208-230/60/1	24.0/27.0	685lbs/311kg

Radial Ice Cooled Serving Counter					
Model	Length	Depth	Height	# of 12x20 Pans Held	Ship Weight
DCRU-IC225	58.44"	36.00"	36.00"	2	369lbs/167kg
DCRU-IC332	75.55"	36.00"	36.00"	3	485lbs/220kg
DCRU-IC440	92.35"	36.00"	36.00"	4	601lbs/273kg
DCRU-IC2	103.32"	36.00"	36.00"	2	540lbs/245kg
DCRU-IC3	103.32"	36.00"	36.00"	3	578lbs/262kg
DCRU-IC4	103.32"	36.00"	36.00"	4	616lbs/279kg
DCRU-IC5	103.32"	36.00"	36.00"	5	654lbs/297kg

Radial Self-Contained LiquiTec® Cold Pan Serving Counter									
Model	Length	Depth	Height	# of 12x20 Pans Held	H.P.	V/Hz/Ph	Amps	BTU	Ship Weight
DCRU-L1	103.32"	36.00"	36.00"	1	1/4	115/60/1	7.5	292	633lbs/287kg
DCRU-L2	103.32"	36.00"	36.00"	2	1/4	115/60/1	7.5	379	679lbs/308kg
DCRU-L3	103.32"	36.00"	36.00"	3	1/4, 1/4	115/60/1	7.5/7.5	292/379	848lbs/385kg
DCRU-L4	103.32"	36.00"	36.00"	4	1/4, 1/4	115/60/1	7.5/7.5	379/379	894lbs/406kg

Radial Self-Contained Mechanically Cooled Serving Counter									
Model	Length	Depth	Height	# of 12x20 Pans Held	H.P.	V/Hz/Ph	Amps	BTU Load	Ship Weight
DCRU-MC225	58.44"	36.00"	36.00"	2	1/4	115/60/1	7.5	379	410lbs/186kg
DCRU-MC332	75.55"	36.00"	36.00"	3	1/4	115/60/1	7.5	569	525lbs/238kg
DCRU-MC440	92.35"	36.00"	36.00"	4	1/4	115/60/1	7.5	758	640lbs/290kg
DCRU-MC2	103.32"	36.00"	36.00"	2	1/4	115/60/1	7.5	379	604lbs/274kg
DCRU-MC3	103.32"	36.00"	36.00"	3	1/4	115/60/1	7.5	569	644lbs/292kg
DCRU-MC4	103.32"	36.00"	36.00"	4	1/4	115/60/1	7.5	758	684lbs/310kg
DCRU-MC5	103.32"	36.00"	36.00"	5	1/4	115/60/1	7.5	948	724lbs/328kg



## Specifications, continued

Transition Counters				
Model	Length	Depth	Height	Ship Weight
DC-T22	25.81"	36.00"	36.00"	86lbs/39kg
DC-T45	38.64"	36.00"	36.00"	171lbs/78kg
DC-T90	59.40"	36.00"	36.00"	315lbs/143kg
DC-TT45	38.64"	36.00"	36.00"	171lbs/78kg
DC-TT90	59.40"	36.00"	36.00"	315lbs/143kg
DCRU-T12	29.39"	36.00"	36.00"	220lbs/100kg
DCRU-T16	38.15"	36.00"	36.00"	235lbs/107kg
DCRU-T20	46.88"	36.00"	36.00"	255lbs/116kg
DCRU-T22	18.92"	36.00"	36.00"	86lbs/39kg
DCRU-T45	37.12"	36.00"	36.00"	171lbs/78kg
DCRU-T90	68.59"	36.00"	36.00"	315lbs/143kg
DCRU-TT45	37.12"	36.00"	36.00"	171lbs/78kg
DCRU-TT90	68.59"	36.00"	36.00"	315lbs/143kg

Beverage Bar Specifications				
Model	Length	Depth	Height	Ship Weight
DCBC-48R	48"	44"	36"	397lbs/180kg
DCBC-72R	72"	44"	36"	460lbs/209kg
DCBC-96R	96"	44"	36"	523lbs/237kg
DCBC-120R	120"	44"	36"	640lbs/290kg

Curved Utility Counter Specifications				
Model	Length	Depth	Height	Ship Weight
DCBU-48R	48.00"	44"	36.00"	297lbs/135kg
DCBU-72R	72.00"	44"	36.00"	360lbs/163kg
DCBU-96R	96.00"	44"	36.00"	423lbs/192kg
DCBU-120R	120.00"	44"	36.00"	540lbs/245kg

Radial Cashier Station Specifications				
Model	Length	Depth	Height	Ship Weight
DCCS-SDR	45.00"	44.00"	36.00"	310lbs/141kg
DCCS-SDRW	45.00"	54.00"	36.00"	390lbs/177kg
DCCS-SDRWL	45.00"	54.00"	36.00"	350lbs/159kg
DCCS-SDRWR	45.00"	54.00"	36.00"	350lbs/159kg
DCCS-DDR	72.00"	44.00"	36.00"	580lbs/263kg
DCCS-DDRW	72.00"	54.00"	36.00"	660lbs/299kg
DCCS-DDRWL	72.00"	54.00"	36.00"	620lbs/281kg
DCCS-DDRWR	72.00"	54.00"	36.00"	620lbs/281kg

Display Merchandiser Specifications				
Model	Length	Depth	Height	Ship Weight
DCDM-24	24.00"	20.00"	36.00"	150lbs/68kg
DCDM-36	36.00"	20.00"	36.00"	125lbs/57kg

## Specifications, continued

Overshelf, Radial Front Specifications				
Model	L	W	H	Ship Weight
DCFSCR	24.00" (61cm)	24.00" (61cm)	16.00" (41cm)	Contact factory
DCFSCRD	24.00" (61cm)	24.00" (61cm)	26.00" (66cm)	Contact factory
DCFSOS-XX	XX"	18.00" (46cm)	16.00" (41cm)	Contact factory
DCFSOS2-XX	XX"	18.00" (46cm)	26.00" (66cm)	Contact factory

Handsink Modules Specifications						
Model	Length	Depth	Height	V/Hz/Ph	Amps	Ship Weight
DCHS-DI	51.00"	36.00"	36.00"	120/60/1	15	220lbs/100kg
DCHS-51	36.13"	28.00"	22.00"	120/60/1	15	454lbs/206kg

Radial Counters Specifications				
Model	Length	Depth	Height	Ship Weight
DCRU-T25	58.44"	36.00"	36.00"	270lbs/122kg
DCRU-T32	75.55"	36.00"	36.00"	345lbs/156kg
DCRU-T40	92.35"	36.00"	36.00"	420lbs/191kg
DCRUO-TT25	58.44"	36.00"	36.00"	270lbs/122kg
DCRUO-TT32	75.55"	36.00"	36.00"	345lbs/156kg
DCRUO-TT40	92.35"	36.00"	36.00"	420lbs/191kg
DCRUI-TT25	58.44"	36.00"	36.00"	270lbs/122kg
DCRUI-TT32	75.55"	36.00"	36.00"	345lbs/156kg
DCRUI-TT40	92.35"	36.00"	36.00"	420lbs/191kg

Tower Module Specifications				
Model	Length	Depth	Height	Ship Weight
DCTM-38RI	38.00"	36.00"	83.62"	516lbs/234kg
DCTM-66RI	66.00"	36.00"	83.62"	774lbs/351kg
DCTM-RI	30"-72"	36.00"	83.62"	Contact factory

## Operation: Heated Units

After plugging in the power supply cord, select desired temperature by rotating the knob on the temperature control panel. Indicator light will come on when the switch is activated. Individual temperature control knobs and indicator lights are provided for each heated food well.

### Before the unit is used the first time for serving:

- Turn the temperature knob to “10” and heat the well for 15 minutes. Do not be alarmed if smoke appears; this preheat should burn off any residue or dust that has adhered to the food well element

If the same temperature settings for each well are used every day, the temperature knobs can be left in their set position and the wells can be turned off using the ON/OFF switch at the end of the control panel.

When serving thick sauces always use the hot food well in “wet” operation. This provides more uniform temperature for the sauce. Product temperature should range from 140°F to 160°F



**Never place food directly in well. Always use pans.**

For most efficient operation, keep empty inset pans empty and covered during preheating and when the well is not in use.

Always place covers on pans when not serving to prevent food from drying out and to reduce your operating costs.

### Wet operation

Fill the food well with about two inches of hot water and cover with lid or empty pan. To bring water to highest temperature, set

temperature control at “High”. With pans in place, wells will boil water. Food temperature will vary depending on type and amount of product. To minimize steam and water usage, set control to lowest setting that will maintain proper food temperature.



**Steam can cause serious burns. Always wear some type of protective covering on your hands and arms when removing lids from the unit. Lift the lid in a way that will direct escaping steam away from your face and body. Water temperature will average 180°F.**

### Dry operation

Wet operation is usually much more efficient and is usually preferred. However, these units may be operated without water with no damage to the unit.



**The dry well should never be preheated longer than 15 minutes. Only 6” deep pans should be used with dry food wells.**



**When operated dry, the well bottoms become very hot. Do not allow unprotected skin to contact any well surface.**

When operated dry, the bottom of the well will discolor. To clean, use a stainless steel cleaner or mild abrasive.

### Operation of optional heated understorage

Preheat the heated understorage to desired temperature. Temperature range of understorage is 80°F to 190°F. The temperature control knob is always the far left knob on the panel. Indicator light is also at the far left.

## Operation: Mechanically Cooled Serving Counters

Mechanically cooled cold pans are adjusted at the factory to provide proper operation without any further adjustments. However, if it is necessary to adjust the temperature, the control is located in the machine compartment. Turn the knob clockwise as indicated on the control. Settings are from 1 thru 7, 7 being the coldest. Adjustments should be made gradually. Several small adjustments will be more effective than one large adjustment. It may take an hour or longer to realize the temperature change depending on the application and location of the unit.

Turn the cold pan on an hour or longer before loading product to achieve the desired temperature.

These units are not designed to cool warm food products. Items should be placed in the unit pre-cooled at least to the desired holding temperature, if not slightly colder. In some applications, a gradual warming of product may occur, particularly at the exposed top of the product. Stirring or rotation of the product may be necessary to maintain overall temperature.

Warming of food product can occur very quickly outside of the unit. When loading or rotating product, avoid leaving food items in a non-refrigerated location for any length of time to prevent warming or spoilage.

The temperature control is used to turn the unit on and off as well as control the temperature of the cold pan. The settings range from 1 through 7, 7 being the coldest. To turn the cold pan off, turn the knob to the OFF position.

These units are not designed to be used with ice. If the cold pan is to be used with ice, it is recommended that the optional perforated bottoms be used. These will allow ice to melt properly.

The unit must be turned off when not in use or overnight for defrosting and cleaning.

## Operation: LiquiTec Units

There is a switch on the compressor housing front to turn the units on and off. LiquiTec Series cold pans are adjusted at the factory to provide proper operation without any further adjustments. However, if it is necessary to adjust the temperature, the control is located in the machine compartment. Turn the knob clockwise as indicated on the control to adjust it colder. Adjustments should be made gradually. Several small adjustments will be more effective than one large adjustment. It may take an hour or longer to realize the temperature change depending on the application and location of the unit.

Turn the cold pan on an hour or longer before loading product to achieve the desired temperature.

These units are not designed to cool warm food products. Items should be placed in the unit pre-cooled at least to the desired holding temperature, if not slightly colder. In some applications, a gradual warming of product may occur, particularly at the exposed top of the products. Stirring or rotation of the product may be necessary to maintain overall temperature. Warming of food product can occur very quickly outside of the unit. When loading or rotating the product, avoid leaving food items in a non-refrigerated location for any length of time to prevent warming or spoilage.



The cold pan is not intended to be used with ice.

The unit must be turned off when not in use or overnight for defrosting and cleaning.

Temperature Control Settings:

17°F (8°C) differential

25°F (-4°C) cut-in

8°F (-13°C) cut-out

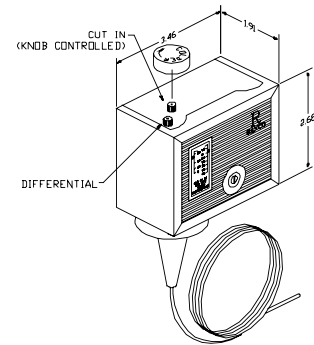

## Operation: Frost Top Serving Counters

Frost tops are designed to maintain an even layer of frost to pleasantly display product. Once turned on, the compressor will run continuously. The unit should be turned off overnight or when not in use. There is no temperature control on the frost top series. The ON/OFF switch is the only means available to cycle the unit.

Since it takes time for the frost to accumulate initially, the unit should be turned on approximately one hour before it is actually required.

Product should not be placed on the frost top prior to turning the unit on, because it may freeze to the surface of the unit.

The unit must be turned off when not in use or overnight for defrosting and cleaning.

## Operation: Mobile Hand Sink



The hand sink is to be used for hand washing only, not for consumption.

CAUTION



Hot water heater **MUST** be filled with water before connecting the water heater to power to prevent damage to the heater.

The fresh water and waste water containers are located in the base of the sink compartment on the right. The fresh water containers are on the left with clear vinyl tubing and waste water tanks are on the right with a rigid drain tube. Two fresh water and two waste water containers are provided with each unit.

To add water to the fresh water container, remove the cap the vinyl tubing is connected to on the container by pressing the button on the cap and pull out the cap from the container. Pull the container out of the sink base and unscrew the cap of the fill access hole at the back of the container. Fill the container with water and screw the cap back on at the back of the container and push the cap with the vinyl tubing back into place at the front. Make sure there are no kinks in the clear vinyl tubing.

Verify the black waste arm at the end of the drain line is in the hole on the waste container.

### Before Operating The Sink:

Water heater **MUST** be filled with water before connecting the water heater to power to prevent damage to the heater.

Before plugging the sink into a wall receptacle, verify the water pump only is plugged into the GFCI receptacle in the base of the unit. If the water heater is plugged in, unplug it until the heater has been filled with water. Put the switch and the breaker to the "ON" position in the base of the unit. Make sure the GFCI receptacle is ON.

To fill the water heater with water, turn on the hot water handle on the faucet until water flows. When water flows into the sink, the water heater is filled with water. The water heater can now be plugged into the GFCI. Verify the water heater power switch on the front of the heater is ON. The red light on the switch will stay on until it has reached the set temperature.

Changing containers:

To switch out the waste water containers, get as much residual water out of the drain into the container before removing. Lift the black elbow out of the container and pull part of the drain line through the hole in the compartment center divider to create an elbow in the drain line to prevent water from draining out while switching out the containers. When the empty container is in place, pull the drain line back through the center divider and put the black elbow into the hole in the container.

To prevent waste water overflow:

- Switch the fresh water and waste water containers at the same time.
- Do not pour excess liquids into the sink

To adjust the water temperature, refer to the water heater manufacturer's manual provided with the unit.

The hot water heater and the water pump is on a sliding shelf. Use the handle provided in the shelf slide it out to access the heater and other components.

The soap dispenser container is located in the base of the unit. The container is threaded into the soap dispenser pump. Liquid soap only is to be used in the soap dispenser.

## Operation: Tower Module

Verify the module is plugged into a receptacle and the Reach-In is plugged into the GFCI receptacle. If lights were provided, turn on the on /off switch on the back of the tower.

**The flanged feet must be bolted to the floor.**

## Maintenance

### Drain Maintenance - Base

Each unit has a drain located inside the unit that removes the condensation from the evaporator coil and routes it to an external condensate evaporator pan. Each drain can become loose or disconnected during normal use. If you notice water accumulation on the inside of the unit be sure the drain tube is connected to the evaporator drain pan. If water is collecting underneath the unit make sure the end of the drain tube is in the condensate evaporator in the machine compartment. The leveling of the unit is important as the units are designed to drain properly when level. Be sure all drain lines are free of obstructions.

### Caster Maintenance

Wipe casters with a damp cloth monthly to prevent corrosion.



**The power switch must be turned to OFF and the unit disconnected from the power source whenever performing service, maintenance functions or cleaning the refrigerated area.**

### Refrigerators and Freezers

The interior and exterior can be cleaned using soap and warm water. If this isn't sufficient, try ammonia and water or a nonabrasive liquid cleaner. When cleaning the exterior, always rub with the "grain" of the stainless steel to avoid marring the finish. Do not use an abrasive cleaner because it will scratch the stainless steel and can damage the breaker strips and gaskets.

### Stainless Steel Care and Cleaning

To prevent discoloration or rust on stainless steel several important steps need to be taken. First, we need to understand the properties of stainless steel. Stainless steel contains 70- 80% iron, which will rust. It also contains 12-30% chromium, which forms an invisible passive film over the steel's surface, which acts as a shield against corrosion. As long as the protective layer is intact, the metal is still stainless. If the film is broken or contaminated, outside elements can begin to breakdown the steel and begin to form discoloration or rust. Proper cleaning of stainless steel requires soft cloths or plastic scouring pads.

### NEVER USE STEEL PADS, WIRE BRUSHES OR SCRAPERS!

Cleaning solutions need to be alkaline based or non-chloride cleaners. Any cleaner containing chlorides will damage the protective film of the stainless steel. Chlorides are also commonly found in hard water, salts, and household and industrial cleaners. If cleaners containing chlorides are used be sure to rinse repeatedly and dry thoroughly. Routine cleaning of stainless steel can be done with soap and water. Extreme stains or grease should be cleaned with a non-abrasive cleaner and plastic scrub pad. Always rub with the grain of the steel. There are stainless steel cleaners available which can restore and preserve the finish of the steels protective layer. Early signs of stainless steel breakdown are small pits and cracks. If this has begun, clean thoroughly and start to apply stainless steel cleaners in attempt to restore the passivity of the steel.



**Never use an acid based cleaning solution! Many food products have an acidic content, which can deteriorate the finish. Be sure to clean the stainless steel surfaces of ALL food products. Common items include, tomatoes, peppers and other vegetables.**

### Cleaning the Condenser Coil

In order to maintain proper refrigeration performance, the condenser fins must be cleaned of dust, dirt and grease regularly. It is recommended that this be done at least every three months. If conditions are such that the condenser is totally blocked in three months, the frequency of cleaning should be increased. Clean the condenser with a vacuum cleaner or stiff brush. If extremely dirty, a commercially available condenser cleaner may be required.

Failure to maintain a clean condenser coil can initially cause high temperatures and excessive run times. Continuous operation with a dirty or clogged condenser coil can result in compressor failure. Neglecting the condenser coil cleaning procedures will void any warranties associated with the compressor and cost to replace the compressor.



**Never use a high-pressure water wash for this cleaning procedure as water can damage the electrical components located near or at the condenser coil.**

### Preventing blower coil corrosion

To help prevent corrosion of the blower coil, store all acidic items, such as pickles and tomatoes, in sealable containers. Immediately wipe up all spills.



**Units with pans should be operated with pans in place. Operating the unit without all pans in place will lower efficiency and may damage the unit.**

### Defrosting

Refrigerated cold pans and frost tops should be defrosted daily. On/ Off switch located above louver panel.

**Never use sharp objects or tools to clean or scrape ice/frost build up from the refrigerated cold pans or frost tops. A puncture to the pan could cause irreparable damage to the refrigeration system.**

**Units with a Eutectic Fluid Cold Pan require the same precautions. The fluid is NOT refillable and loss of fluid due to a puncture would cause irreparable damage.**

Over shelves and other items mounted to the top of the counters should never be installed in the field due to the potential damage to the refrigeration system.

# Wiring Diagram, Heated Serving Counter

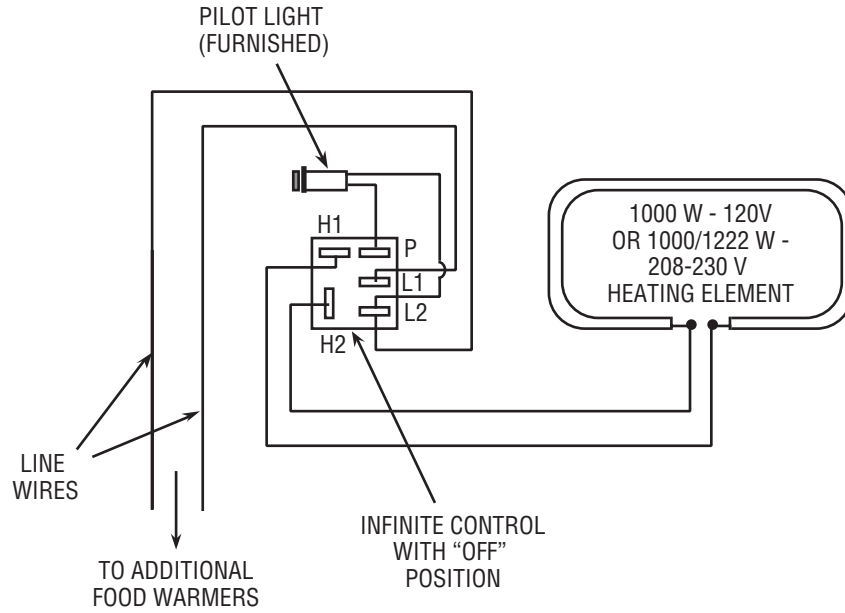

AMPERES IN LINE WIRES

# OF WARMERS	120V, 1 PHASE	208V, 1 PHASE	230V, 1 PHASE	208-230V, 3 PHASE		
				L1	L2	L3
2	16.7	9.6	10.6			
3	25	14.4	15.9	14.4/15.9	14.4/15.9	14.4/15.9
4	33.3	19.2	21.3	19.2/21.3	19.2/21.3	14.4/15.9
5		24	26.6	24/26.1	19.2/21.3	19.2/21.3
6		28.8	31.3	28.8/31.3	28.8/31.3	28.8/31.3

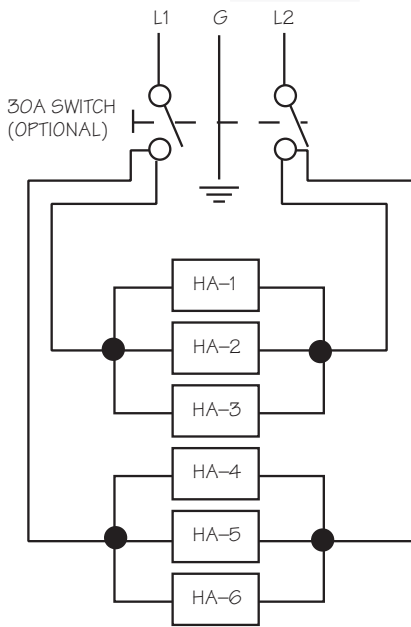

HA = HEATER ASSEMBLY  
**Standard Single Phase**

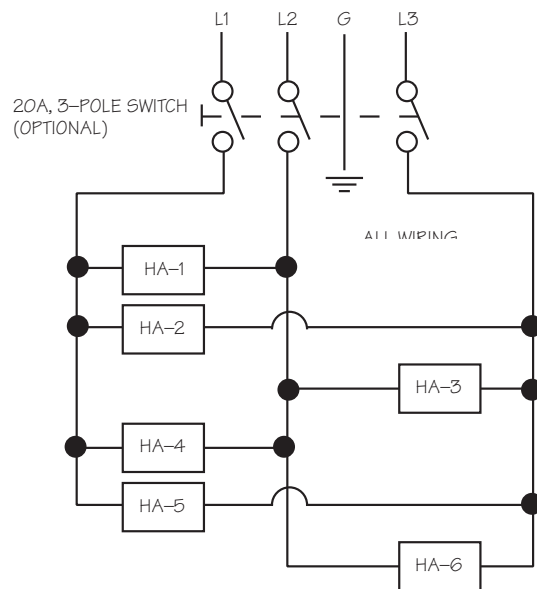

HA = HEATER ASSEMBLY  
**Optional Three Phase**

## Wiring Diagram, Self-Contained Mechanically Cooled Serving Counter

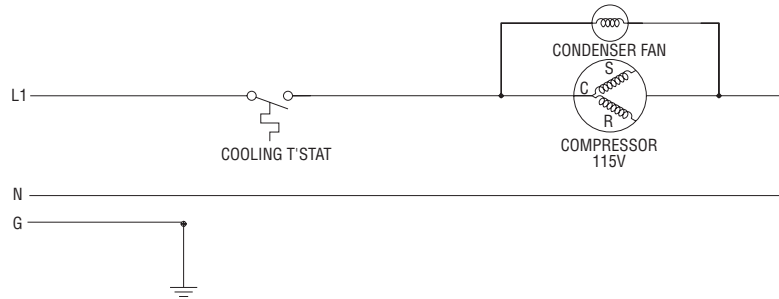

## Wiring Diagram, Self-Contained LiquiTec® Cold Pan Serving Counter

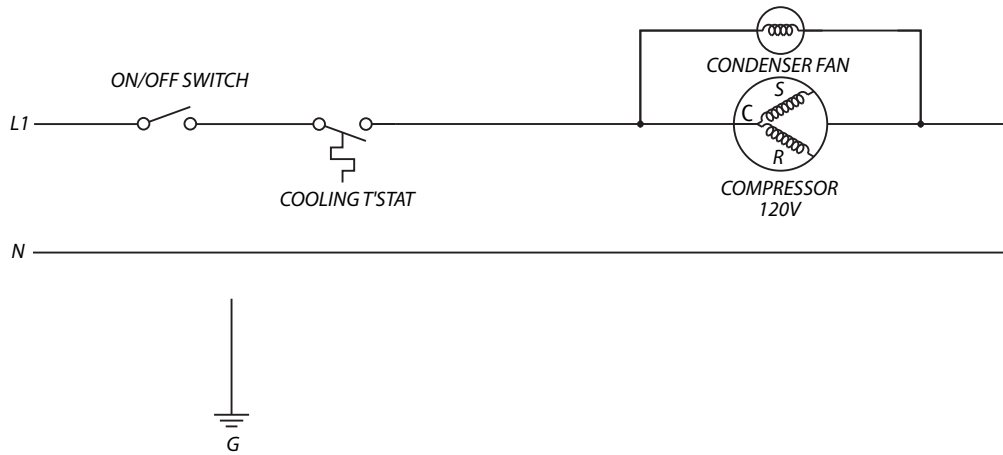

## Wiring Diagram, Self-Contained Frost Top Serving Counter

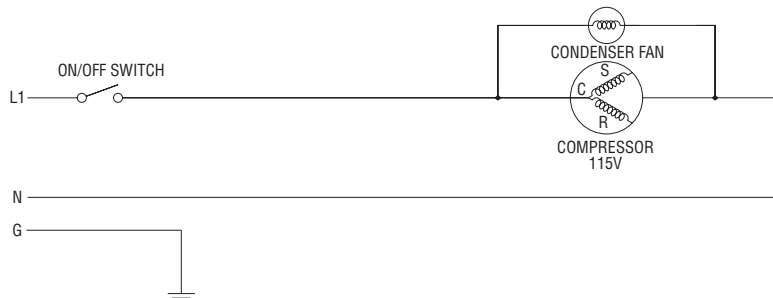

# Wiring Diagram, Tower Module

WIRING FOR TOWER  
NEMA 5-20R OUTLET W/ BREAKER

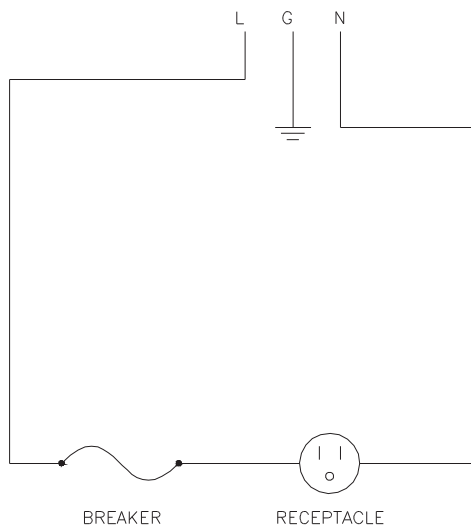

WIRING FOR TOWER  
NEMA 5-20R OUTLET W/ BREAKER  
WITH LIGHTS AND SWITCH

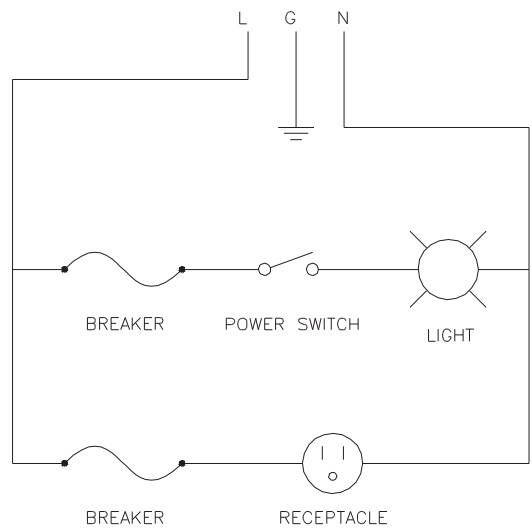

# Wiring Diagram, Mobile Hand Sink

WIRING FOR HANDSINK UNIT  
NEMA 5-15R OUTLET W/ BREAKER

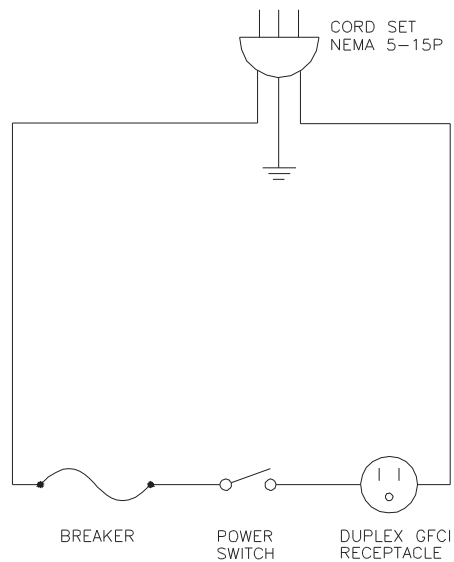

## Replacement Parts

### Sink Assembly

Key	Part No.	Description
1	2194099	Switch, SPST, 15 Amp
2	3235056	Soap Dispenser, Tough Guy
3	1701410	Waste Arm, Black ABS
4	1701413	Coupling, Colder
5	9324097	Clamp, Oetiker
6	1701411	Hose, NewFlex, 1.5"ID
7	1702078	Tubing, Vinyl, 1/2"ID x 3/4"OD
8	1701418	Container, Water, Waste
9	1701417	Container, Water, Fresh, 5
10	3235051	Pump, Water, Shurflo*
11	3235050	Heater, Water, Ariston*
12	1701416	Pipe, PVC, 3/4"
13	1701415	Elbow, PVC, 3/4"
14	2194328	Breaker
15	1701414	Adaptor, 3/4" MPT
16	3545340	Line, Supply, Water, 30" LG
17	3235053	Hammer, Water, 1/2M STR
18	3545343	Tee, Brass, 1/2" x 1/2" x 1/2"
19	3545341	Line, Supply, Water, 20" LG
20	1701412	Fitting, Elbow, Nylon
21	3545344	Elbow, Brass, 3/8"NPT-3/8"BPT
-	3235054	Aerator
-	3235500	Cap, Threaded, 1", DC
-	3234902	Caster, 5", Plate, swivel
-	3234783	Caster, 5", Plate, swivel w/ brake
-	3234156	Catch, Magnetic, Snap-In
-	2183348	Cord, Lead, 16/3 W Nema 5-15P
-	2193450	Cover, Weather Proof
-	3234077	Faucet, Deck, FSHR#3510
-	3234067	Hinge, Flag
-	2194443	Receptacle, GFCI, 15Amp
-	3235555	Spacer, PNL Bolt Washer
-	3235052	Strainer, Sink, 2-1/2"

\*Heater and pump warranty will be covered by Delfield instead of OEM.

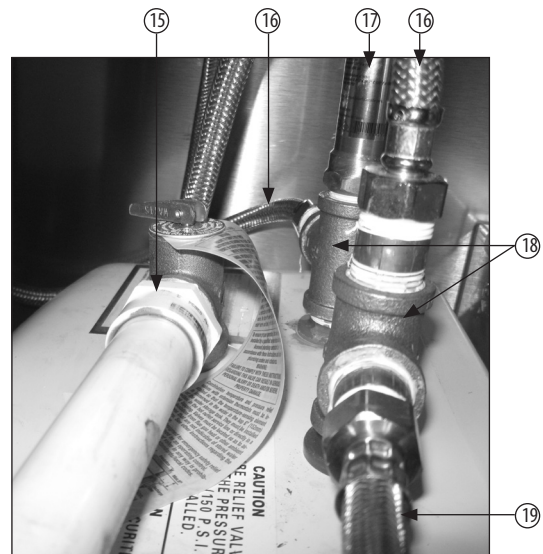
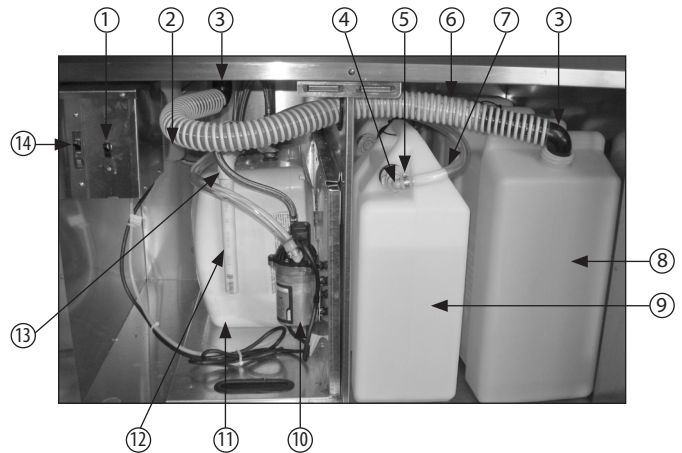

## Replacement Parts, continued

### Tower Module

3235500	Cap, Threaded, 1"
3234452	Flanged Food
2195286	Gooseneck light
2194444	Receptacle, GFCI 5-20R
2190154	Switch, Rocker 20A/125V, 15A, 250V

### Beverage Module

3235500	Cap, Threaded, 1"
3234243	Door Hinge
3234272	Door Hinge Mounting Plate
3234645	Leg

### DC-FT Frost Tops

3234156	Catch, magnetic, snap-in
*000-BN5-0030	Condensing unit 1/4 hp
3234067	Hinge, flag
3234645	Leg
000-585-0032	Louver assy, 18" Left hand
2194099	Switch, SPST 15A, Brown
3516225	Valve, expansion, 1/4, low

### DC-H Heated Serving Counter

3234156	Catch, magnetic snap-in
3234572	Drain Screen
3234075	Faucet, hot food table
3234645	Leg
2194095	Light, pilot, 250V Amber
000-585-0034	Louver assy, 18 x 11.75, left hand
2194212	Switch, 30A, 120/277V, DPST
*0160193	Warmer, food, 208V, Infinite Control, w/ drain

### DC-IC Ice Cooled Counter

3234645	Leg
3234242	Plastic Drain, 1PS, 2.87Long

### DC-L Liquitech

3234156	Catch, magnetic, snap-in
*000-BN5-0030	Condensing unit 1/4 hp
3234645	Leg
000-585-0032	Louver access door Assy, 18", Left
2190154	Switch, rocker, 20A/125V,15A/250V
000-282-0051	Tstat Assy, Danfoss
3516225	Valve, expansion, 1/4, low

### DC-MC Mechanically cooled cold pan

*000-BN5-0030	Condensing unit 1/4 hp
3234645	Leg
000-585-0032	Louver access door Assy, 18", Left
2190154	Switch, rocker, 20A/125V, 15A/250V
2194201	Thermostat
3516225	Valve, expansion, 1/4, low

\* Exploded view on next page.

## Replacement Parts, continued

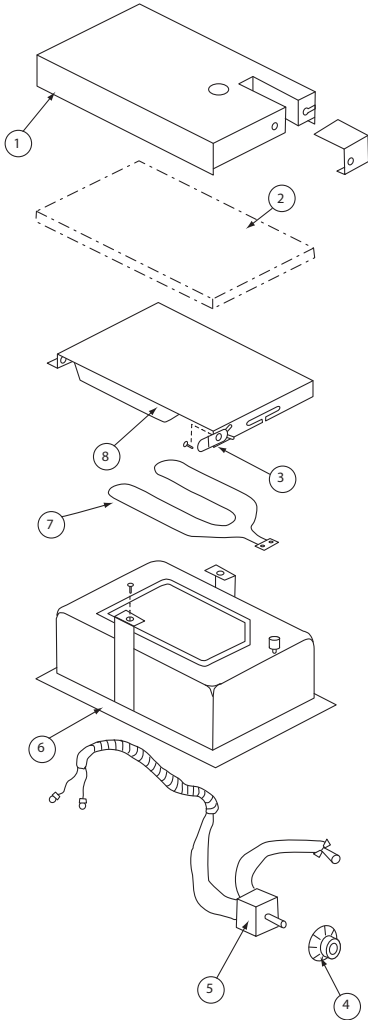

Key	Part No.	Description
	<b>0160193</b>	<b>Complete assembly, 208V, w/drain</b>
1	026-103-Z0006	Bottom cover
2	3434663	Insulation
3	2194335	Thermostat non-adjustable
4	3234557	Knob
5	2194110	Infinite control, 230V
6	0160014	Food well, with drain
7	2194007	Element, 208V
8	026-061-0001-S	Deflector plate

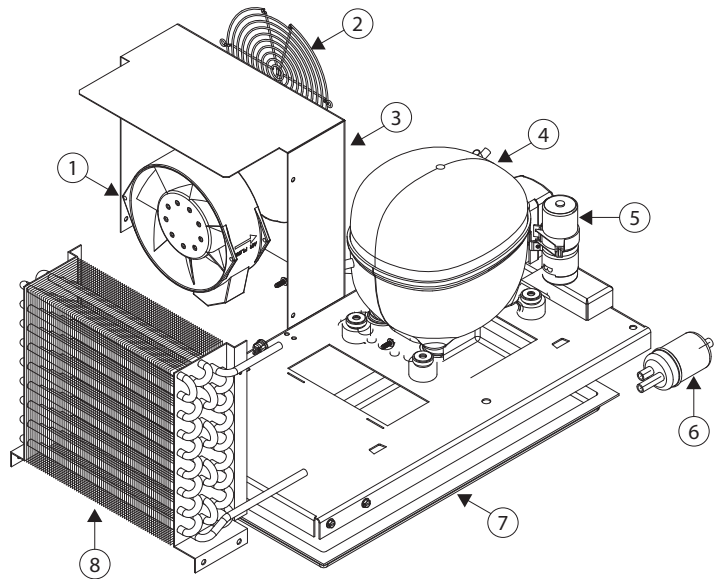

Key	Part No.	Description
-	<b>000-BN5-0030</b>	<b>Condensing Unit, 1/4HP</b>
1	2160028	Fan, Axial, 5.5" 120V
2	2160030	Fan Guard, 6.0"
3	026-C58-0037	Shroud, Condenser Coil
4	3526999	Danfoss Compressor
5	3516444	Compressor Relay
5	2194787	Start Capacitor
6	3516322	Filter Drier
7	075-231-0030	Condensate Pan
8	3516454	Condenser Coil

## Standard Labor Guidelines To Repair Or Replace Parts On Delfield Equipment

Advice and recommendations given by Delfield Service Technicians do not constitute or guarantee any special coverage.

- A maximum of 1-hour is allowed to **diagnose a defective component**.
- A maximum of 1-hour is allowed for **retrieval of parts** not in stock.
- A maximum **travel distance** of 100 miles round trip and 2-hours will be reimbursed.
- Overtime, installation/start-up, normal control adjustments, general maintenance, glass breakage, freight damage, and/or correcting and end-user installation error will not be reimbursed under warranty unless pre-approved with a **Service Work Authorization** from Delfield. You must submit the number with the service claim.

### LABOR OF 1-HOUR IS ALLOWED TO REPLACE:

- Thermostat
- Infinite Switch
- Door Jamb Switch
- Solenoid Coil
- Hi-limit/Thermal Protector Switch
- Compressor Start Components and Overload Protector
- Defrost Timer
- Thermometer
- Contactor/Relay
- Transformer
- Evaporator/Condenser Fan Motor and Blade
- Circulating Fan Motor and Blade
- Fan Delay/Defrost Termination Switch
- Door Hinges, Locks, and Gaskets
- Condensate Element
- Springs/Lowerator

### LABOR OF 2 HOURS TO REPLACE:

- Drawer Tracks/Cartridges
- Pressure Control
- Solenoid Valve
- Defrost Element
- Heating Element
- Locate/Repair Leak

### LABOR OF 3 HOURS TO REPLACE:

- EPR or CPR Valve
- Expansion Valve
- Condenser or Evaporator Coil

### LABOR OF 4 HOURS TO REPLACE

- Compressor

This includes recovery of refrigerant and leak check.

\$55.00 maximum reimbursement for refrigerant recovery (includes recovery machine, pump, torch, oil, flux, minor fittings, solder, brazing rod, nitrogen, or similar fees.)

### REFRIGERANTS

- R22 A maximum of \$4.00/lb. or 25¢/oz. will be reimbursed.
- R134A A maximum of \$5.00/lb. or 31¢/oz. will be reimbursed.
- R404A A maximum of \$15.00/lb. or \$1.00/oz. will be reimbursed.

**Notes**



# Notes

Notes





**Mt. Pleasant, MI**



**Covington, TN**

*Thank you for choosing Delfield!*

Help is a phone call away. Help our team of professional, courteous customer service reps by having your model number and serial number available at the time of your call (800) 733-8829.

Model: \_\_\_\_\_ S/N: \_\_\_\_\_

Installation Date: \_\_\_\_\_



For a list of Delfield's authorized parts depots, visit our website at [www.delfield.com](http://www.delfield.com)

Register your Delfield warranty online. Go to [www.delfield.com](http://www.delfield.com) under the service tab to complete.

