

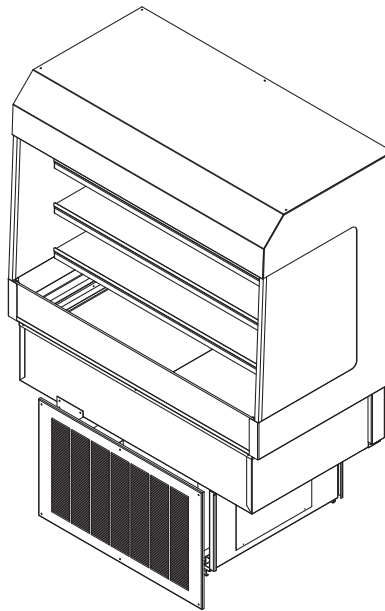

ASM Series

Service and Installation Manual

Please read this manual completely before attempting to install or operate this equipment!
Notify carrier of damage! Inspect all components immediately.



ASM SERIES
Drop-In Air Screen Merchandisers



Important Information
Read Before Use
Please Save These Instructions!

February 2013



Important Warning And Safety Information



WARNING

Read This Manual Thoroughly Before Operating, Installing, Or Performing Maintenance On The Equipment.



WARNING

Failure To Follow Instructions In This Manual Can Cause Property Damage, Injury Or Death.



WARNING

Do Not Store Or Use Gasoline Or Other Flammable Vapors Or Liquids In The Vicinity Of This Or Any Other Appliance.



WARNING

Unless All Cover And Access Panels Are In Place And Properly Secured, Do Not Operate This Equipment.



WARNING

This Appliance Is Not Intended For Use By Persons Who Lack Experience Or Knowledge, Unless They Have Been Given Supervision Or Instruction Concerning Use Of The Appliance By A Person Responsible For Their Safety.



WARNING

This Appliance Is Not To Be Played With.



WARNING

Do Not Clean With Water Jet.



WARNING

Do Not Use Electrical Appliances Inside The Food Storage Compartment Of This Appliance.



CAUTION

Observe the following:

- Minimum clearances must be maintained from all walls and combustible materials.
- Keep the equipment area free and clear of combustible material.
- Allow adequate clearance for air openings.
- Operate equipment only on the type of electricity indicated on the specification plate.
- Unplug the unit before making any repairs.
- Retain this manual for future reference.

Contents

Receiving & Inspecting Equipment.....	3
Serial Number Location	4
Warranty Information.....	4
Regulatory Certifications.....	4
Specifications.....	5
Installation	6-7
Shelf Adjustments.....	8
Operation	9
Sliding Door Removal And Reinstall.....	9
Night & Security Cover Operation.....	9
Maintenance.....	10
Wiring Diagrams.....	11-12
Condensing Unit Assemblies	13-14
Replacement Parts.....	14-16
Temperature Control Settings	17
Standard Labor Guidelines.....	18
Notes	19

Receiving And Inspecting The Equipment

Even though most equipment is shipped crated, care should be taken during unloading so the equipment is not damaged while being moved into the building.

1. Visually inspect the exterior of the package and skid or container. Any damage should be noted and reported to the delivering carrier immediately.
2. If damaged, open and inspect the contents with the carrier.
3. In the event that the exterior is not damaged, yet upon opening, there is concealed damage to the equipment notify the carrier. Notification should be made verbally as well as in written form.
4. Request an inspection by the shipping company of the damaged equipment. This should be done within 10 days from receipt of the equipment.
5. Check the lower portion of the unit to be sure legs or casters are not bent.
6. Also open the compressor compartment housing and

visually inspect the refrigeration package. Be sure lines are secure and base is still intact.

7. Freight carriers can supply the necessary damage forms upon request.
8. Retain all crating material until an inspection has been made or waived.

Uncrating the Equipment

First cut and remove the banding from around the crate. Remove the front of the crate material, use of some tools will be required. If the unit is on legs remove the top of the crate as well and lift the unit off the skid. If the unit is on casters it can be "rolled" off the skid.

Serial Number Location

The serial number on all self-contained Drop-In Air Screen Merchandiser units is located on the mechanical section wall.

Always have the serial number of your unit available when calling for parts or service. A complete list of authorized Delfield parts depots is available at www.delfield.com.

©2013 The Delfield Company. All rights reserved. Reproduction without written permission is prohibited.

Serial #
Model #
Installation Date:

Warranty Information

Visit http://www.delfield.com/minisite/service/warranty_info to:

- Register your product for warranty.
- Verify warranty information.
- View and download a copy of your warranty.

Regulatory Certifications

All models are certified by:



National Sanitation Foundation (NSF)



Underwriters Laboratories (UL)

Specifications

Model	Electrical	Cutout Dimensions	Display Storage	Amps	H.P.	Cabinet Load BTU/ Hour	System Capacity BTU/Hour	R404A Charge	NEMA Plug	Shipping Weight
ASM-36	115V-60Hz-1Ph	35.13" x 25.50" 89cm x 65cm	8.2ft ³	10.8	1/2	4750	5278	32oz	5-15P	425lbs/ 193kg
w/ Condensate Evaporator	115/208-230-60Hz-1Ph								14-20P	
ASM-48	115V-60Hz-1Ph	47.13" x 25.50" 120cm x 65cm	11.3ft ³	12.8	3/4	6250	6944	48oz	5-20P	500lbs/ 227kg
w/ Condensate Evaporator	115/208-230-60Hz-1Ph								14-20P	
ASM-60	115/208-230V-60Hz-1Ph	59.13" x 25.50" 150cm x 65cm	14.4ft ³	12.8	1	8500	9444	64oz	14-20P	575lbs/ 261kg
w/ Condensate Evaporator									14-50P	

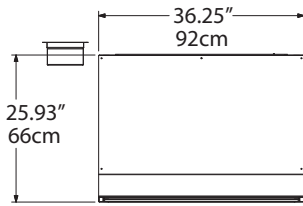

Plan View, ASM-36

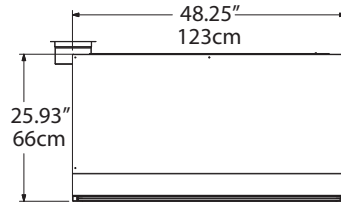

Plan View, ASM-48

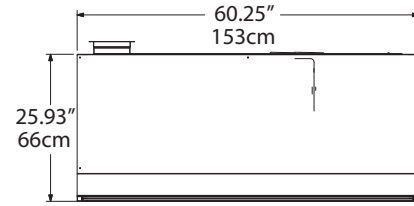

Plan View, ASM-60

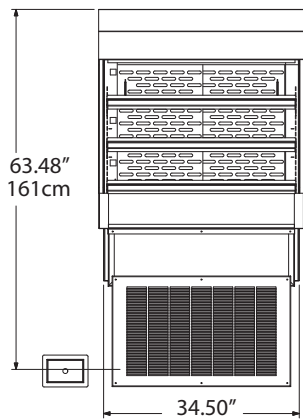

Elevation View, ASM-36

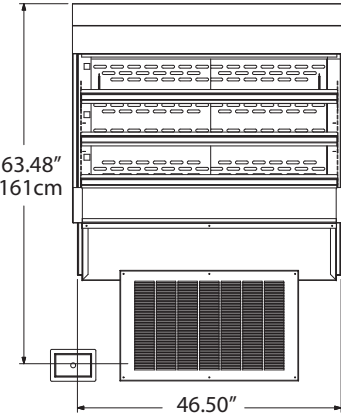

Elevation View, ASM-48

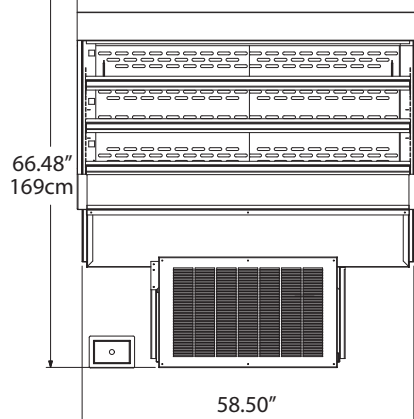

Elevation View, ASM-60

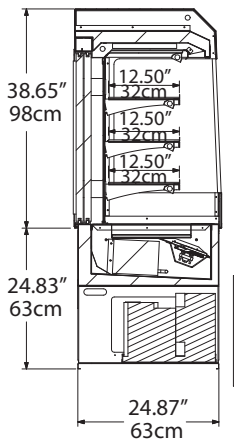

Left Section View, ASM-36, ASM-48

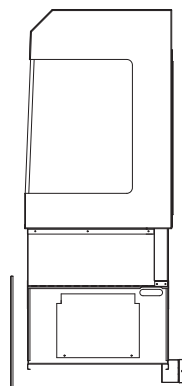

Right Side View, ASM-36, ASM-48

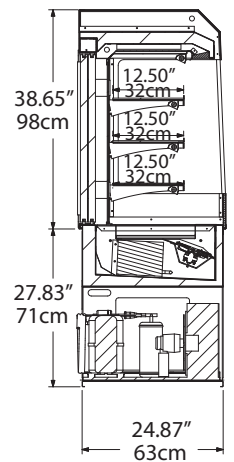

Left Section View, ASM-60

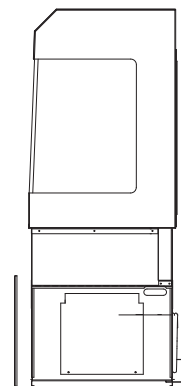

Right Side View, ASM-60

Installation

Location

Unit is designed to maintain 36°F - 40°F (2°C - 4°C) at 80°F (27°C) ambient room temperature in 55% or lower relative humidity.

Units represented in this manual are for indoor use only. Be sure the location chosen has a counter strong enough to support the total weight of the cabinet and contents. A fully loaded model may weigh as much as 1,500 pounds! Reinforce the counter as necessary to provide for maximum loading.

These units are installed by placing them into the counter from above. The counter cutout sizes are as follows:

36" Units - 35.13" x 25.50" (89cm x 65cm)

48" Units - 47.13" x 25.50" (120cm x 65cm)

60" Units - 59.13" x 25.50" (150cm x 65cm)

Two louvers are provided with each unit and must be installed in 17.00" x 28.00" (43cm x 71cm) cutouts. Cut-outs are to begin at 10.00" (25cm) from the counter-top.

For the most efficient refrigeration, be sure to provide good air circulation inside and out. Don't pack the merchandiser so full that air cannot circulate. Avoid hot corners and locations near stoves and ovens.

Air movement in the room will adversely effect ASM refrigeration. Do not place the model near doors or air vents.

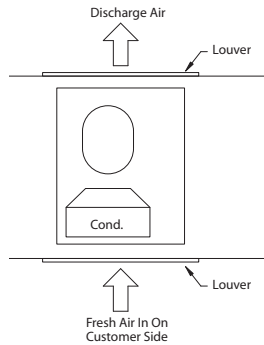

It is recommended that the unit be installed no closer than 1" from any wall. Do not install the unit near any combustible material or object affected by heat or moisture.

Failure to provide the proper air flow will void the warranty.

Plumbing

Standard models will have a 1/2" drain which will need to be run to an appropriate floor drain. The drain will be stubbed inside the machine compartment. All units have an optional electric condensate evaporator. If the evaporator fails, the unit's drain must have an outlet to an appropriate drainage area or container.



Moisture collecting from improper drainage can create a slippery surface on the floor and a hazard to employees. It is the owner's responsibility to provide a container or outlet for drainage.

Electrical connection

Refer to the amperage data on the specification page, the serial tag, your local code or the National Electrical Code to be sure the unit is connected to the proper power source. A protected circuit of the correct voltage and amperage must be run for connection of the line cord, or permanent connection to the unit.

An **ON/OFF** switch is located on the remote control panel. Simply turn the switch to **ON** to begin operation. There is a second **ON/OFF** switch on the remote control panel for the lights.



The power switch should be turned to OFF and the unit disconnected from the power source whenever performing service or maintenance functions.

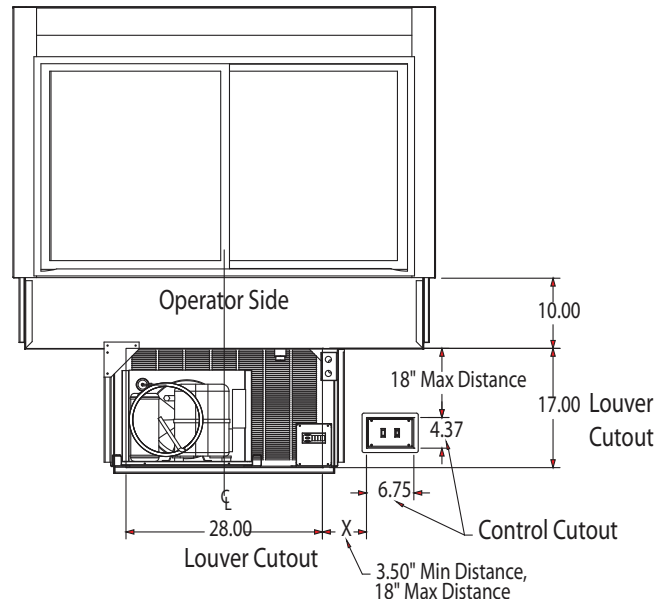
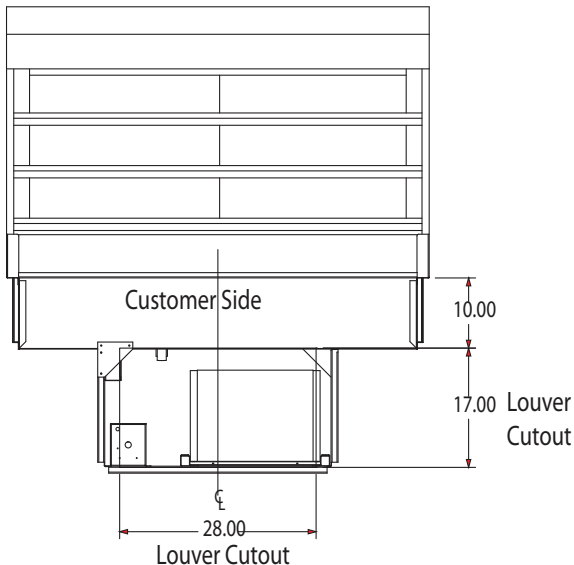

Installation, continued

1. Remove the stainless steel pans in the bottom on the unit.
2. Remove the stainless steel pan clip rail below the door track.
3. Bolt in the lifting plates using the bolts (P/N 9320019) located inside the tank that are installed in the lifting braces.
4. Slide two 1" steel pipes into the lifting plate holes. Place forklift forks under the pipes and clamp the forks and pipes in position.
5. Raise the unit high enough with the forklift to roll the base under the unit into position. Lower the ASM unit into the base using care to clear all of the flanges and screw heads.
6. Remove the bolts and remove the lifting plates. Install plastic plugs (P/NRTPO0067) in the bolt holes.
7. Install the stainless steel pan clip rail below the door track.
8. Install the stainless steel pans in the bottom on the unit making sure the turn down is engaged in the slot below the door track.
9. Install the sneeze guard glass in the clips and attach the end clip with two stainless steel self tapping screws (P/N9321238).
10. Use gray silicone (P/N9291020) to finish the joint between the drop in unit and the top of the base.



Shelf Adjustments

Display cases come with three tempered glass shelves that are adjustable in 1" increments.

Shelves can be slanted at three different angles. Remove the glass and unplug the light before adjusting the shelves.

Maximum weight for 36" shelves is 25 lbs.

Maximum weight for 48" shelves is 35 lbs.

Maximum weight for 60" shelves is 45 lbs.



Overloading shelves can damage equipment or cause bodily injury.

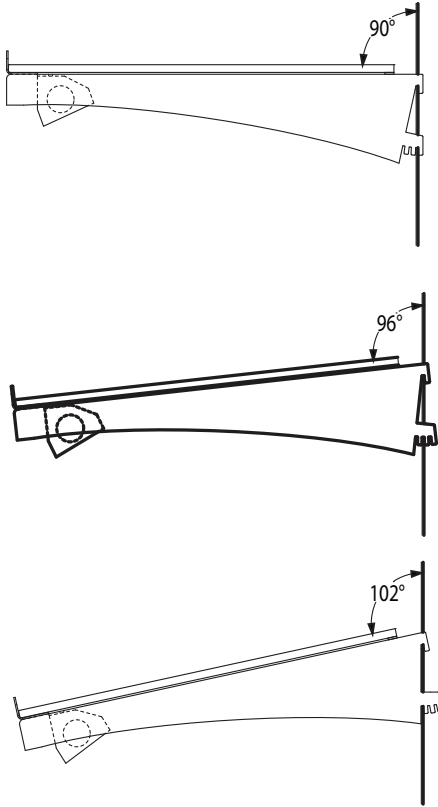

Operation

Located on the Remote Control Panel are two ON/OFF switches. One will turn **ON/OFF** the unit's compressor. The lights are controlled by the other switch.

Delfield's Air Screen Merchandisers are designed to maintain an operational temperature of 36°F - 40°F (2°C - 4°C) at 80°F (27°C) ambient room temperature in 55% or lower relative humidity. Overloading the merchandiser, restricting the air flow, and continuous opening and closing of the doors will hinder the unit's ability to maintain operational temperatures.



If humidity is above 55%, condensation on the glass will be present.

NOTE

Proper airflow is critical to maintaining temperature. Do not interfere with the airflow by placing product over the air return openings. The Air Diffuser Pan Assembly must be properly in place at the bottom of the merchandising case, with the air return openings on the customer side. After cleaning or servicing the Front Deflector Glass, Honeycomb Diffuser and Airduct Plexiglas Panel must be replaced properly.

Sliding Door Removal And Reinstall

Sliding Door Removal

Open the door almost completely. Firmly grasp both sides of the door. Lift the door up and move it until it enters a notch and can be lifted higher. Tilt the bottom out without removing the top. Use the top to gently return the spring to the closed position. Remove the door from the top track.

Sliding Door Reinstall

There is a notch in the top inside corner of the door. Put the spring in the door's notch and move the spring to the open position. Put the top into the track and find the notch where the door can be lifted higher. Set bottom of the door into the track.

Night & Security Cover Operations

At the factory, the keys are taped to the display case. Pull the cover down, turn the key 90° to lock.

Maintenance

Drain Maintenance

Each unit has a drain located inside the unit that removes the condensation from the evaporator coil. The drain can become loose or disconnected during normal use. If you notice water accumulation be sure the drain tube is connected. Be sure drain lines are free of obstructions.



The power switch must be turned to OFF and the unit disconnected from the power source whenever performing service, maintenance functions or cleaning the refrigerated area.

Plexiglas, Including Baffles

Wet a clean cloth with lukewarm water and dishwashing liquid. Apply only light pressure, rinse with clean water and blot dry with a damp chamois. For excessively dirty surfaces, rinse surface dirt off before washing. Fine scratches will disappear when you polish by hand with a plastic cleaner polish.



Never use window sprays, kitchen scouring compounds or solvents such as acetone, gasoline, benzene, alcohol, carbon tetrachloride or lacquer thinner to clean plexiglas.

Stainless Steel Care and Cleaning

To prevent discoloration or rust on stainless steel, first we need to understand the properties of stainless steel. Stainless steel contains 70- 80% iron, which will rust. It also contains 12-30% chromium, which forms an invisible passive film over the steel's surface, which acts as a shield against corrosion. As long as the protective layer is intact, the metal is still stainless. If the film is broken or contaminated, outside elements can begin to breakdown the steel and begin to form discoloration or rust. Proper cleaning of stainless steel requires soft cloths or plastic scouring pads.

NEVER USE STEEL PADS, WIRE BRUSHES OR SCRAPERS!

Routine cleaning of stainless steel can be done with soap and water. Extreme stains or grease should be cleaned with a non-abrasive cleaner and plastic scrub pad. Always rub with the grain of the steel. There are stainless steel cleaners available which can restore and preserve the finish of the steels protective layer. Cleaning solutions need to be alkaline based or non-chloride cleaners. Any cleaner containing chlorides will damage the protective film of the stainless steel. Chlorides are also commonly found in hard water, salts, and household and industrial cleaners. If cleaners containing chlorides are used be sure to rinse repeatedly and dry thoroughly. Early signs of stainless steel breakdown are small pits and cracks. If this has begun, clean thoroughly and start to apply stainless steel cleaners in attempt to restore the passivity of the steel.



Never use an acid based cleaning solution! Many food products have an acidic content, which can deteriorate the finish. Be sure to clean the stainless steel surfaces of ALL food products. Common items include, tomatoes, peppers and other vegetables.

Display Case



Do not throw items into the merchandiser. Failure to follow this recommendation could result in damage to the interior or blower coil. Overloading, restricting the airflow, and continuous opening and closing of the doors will hamper the units ability to maintain operational temperature.

Cleaning the Condenser Coil

In order to maintain proper refrigeration performance, the condenser fins must be cleaned of dust, dirt and grease regularly. It is recommended that this be done at least every three months. If conditions are such that the condenser is totally blocked in three months, the frequency of cleaning should be increased. Clean the condenser with a vacuum cleaner or stiff brush. If extremely dirty, a commercially available condenser cleaner may be required.

Failure to maintain a clean condenser coil can initially cause high temperatures and excessive run times. Continuous operation with a dirty or clogged condenser coil can result in compressor failure. Neglecting the condenser coil cleaning procedures will void any warranties associated with the compressor and cost to replace the compressor.



Never use a high-pressure water wash for this cleaning procedure as water can damage the electrical components located near or at the condenser coil.

Sliding Doors

Frequent, regular cleaning with a mild soap and water solution will keep the tracks free of foreign matter and will insure many years of service. The glass may be cleaned with one of the many commercial glass cleaners currently available.

Preventing blower coil corrosion

To help prevent corrosion of the blower coil, store all acidic items, such as pickles and tomatoes, in sealable containers. Immediately wipe up all spills.

Wiring Diagrams, ASM-36 & ASM-48

VOLTAGE (NO CONDENSATE EVAP): 115V-60HZ-1PH
VOLTAGE (WITH CONDENSATE EVAP): 115/208-220V-60HZ-1PH

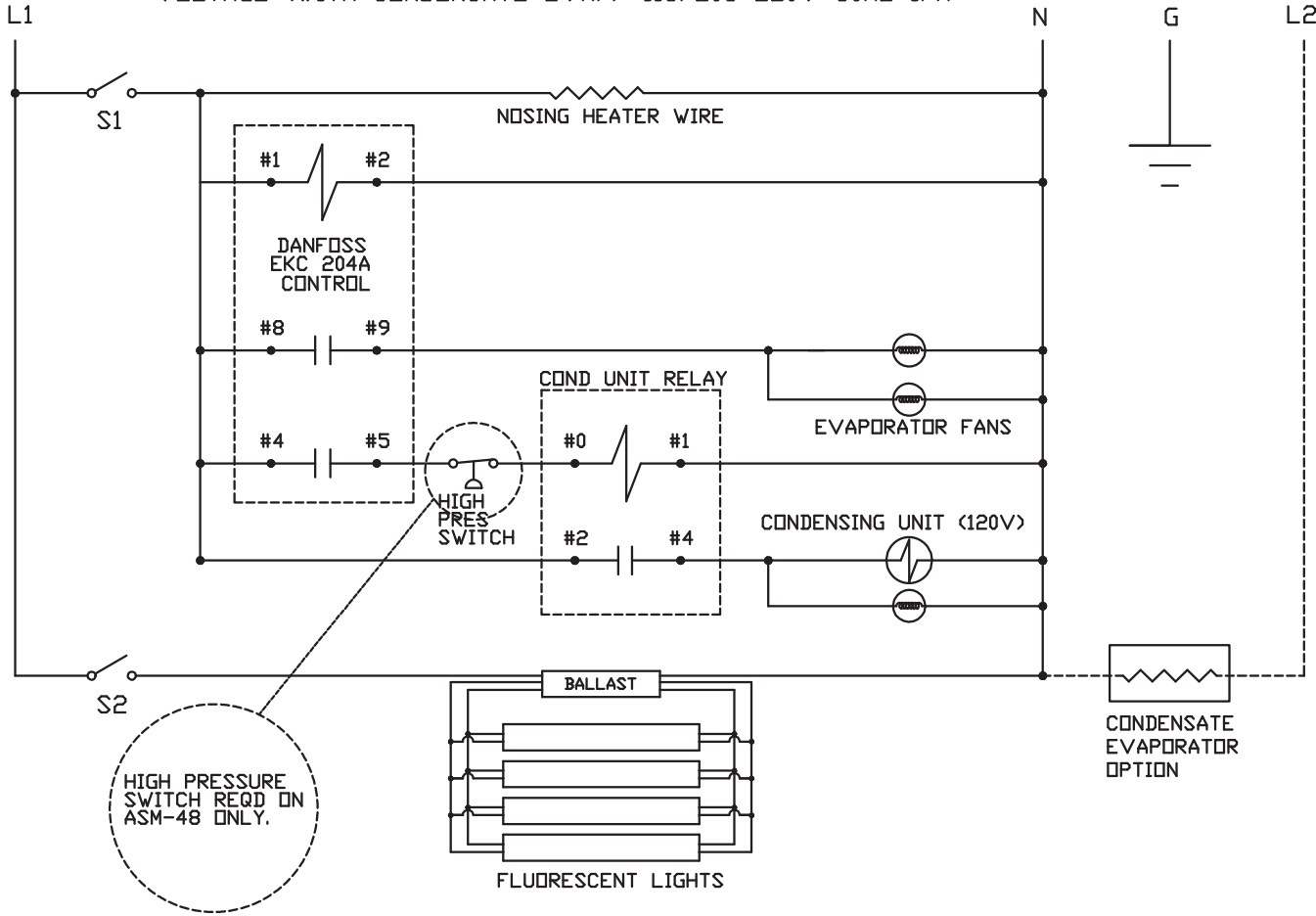

Wiring Diagrams, ASM-60

VOLTAGE (NO CONDENSATE EVAP): 208-240V-60HZ-1PH
 VOLTAGE (WITH CONDENSATE EVAP): 208-240V-60HZ-1PH

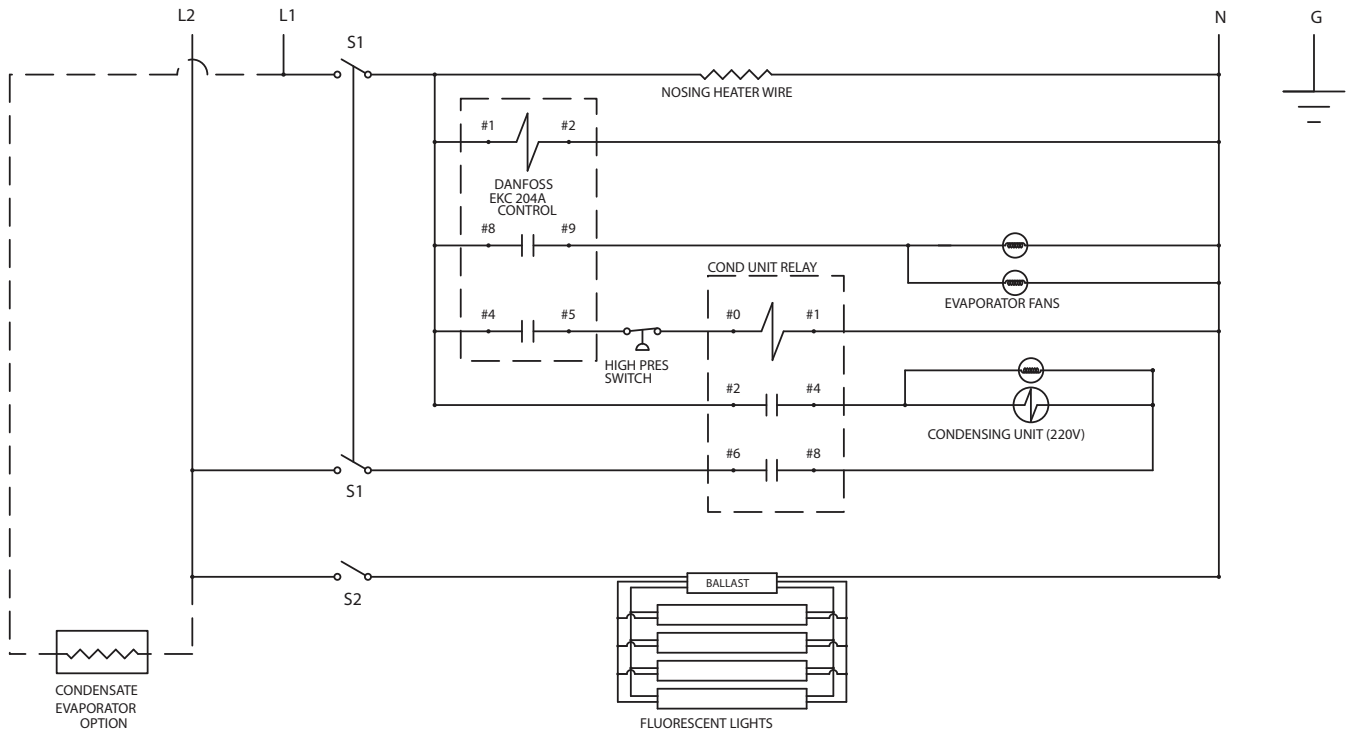

Wiring Diagrams, Remote Models, ASM-36R, ASM-48R, ASM-60R

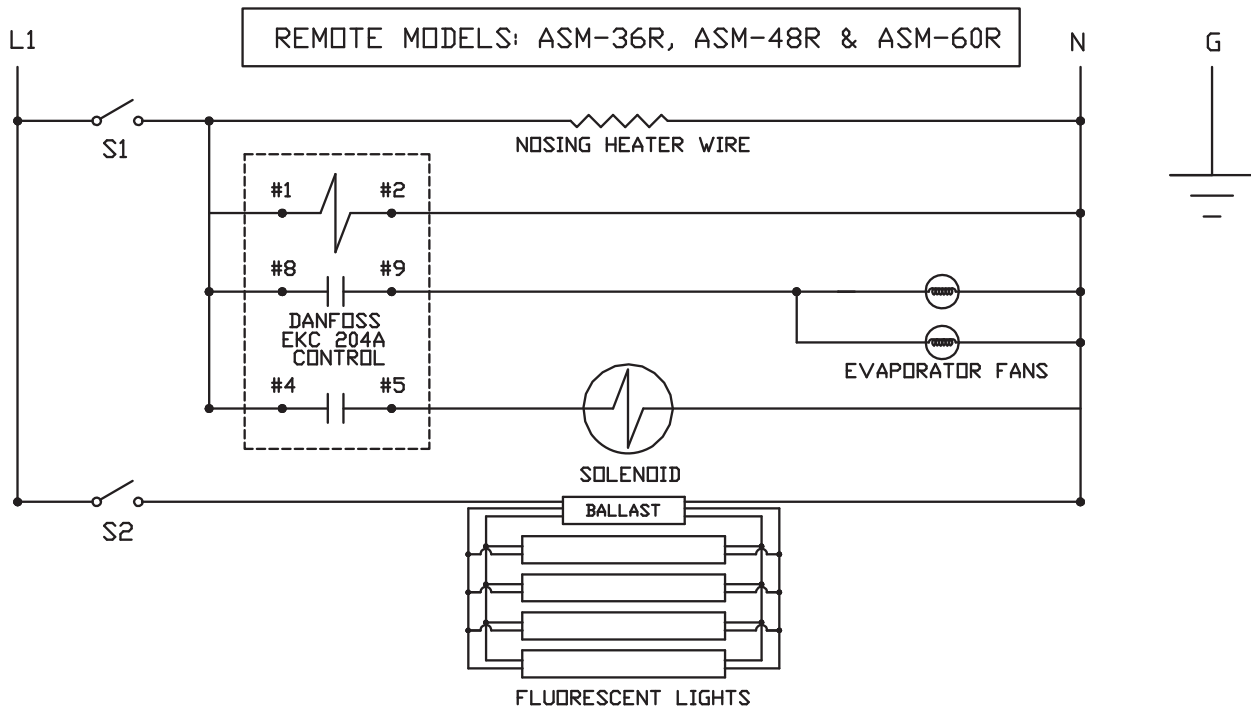

ASM-36 Condensing Unit Assembly 1/2 H.P.

Key	Delfield Part #	Description
-	000-BN5-0035	Condensing Unit Assembly
1	026-C58-0031	Shroud, 1/2 HP condenser coil
2	3516554	Blade, fan 9.00", 5 pedal
3	2160019	Guard, fan, condenser, upright
4	2162716	Motor, fan, 16W, 115V
5	3516462	Capacitor, start, assembly
6	3527026	Compressor, SC12MLX, 115V/60Hz, Danfoss
7	3516331	High pressure switch
8	3516322	Filter dryer, (2) inlet, .25"
9	3516459	Tank, receiver
10	075-231-0031	Pan, condensate
11	3516455	Coil, 1/2 HP condensing
-	000-282-009F	Control Assembly, ASM-36

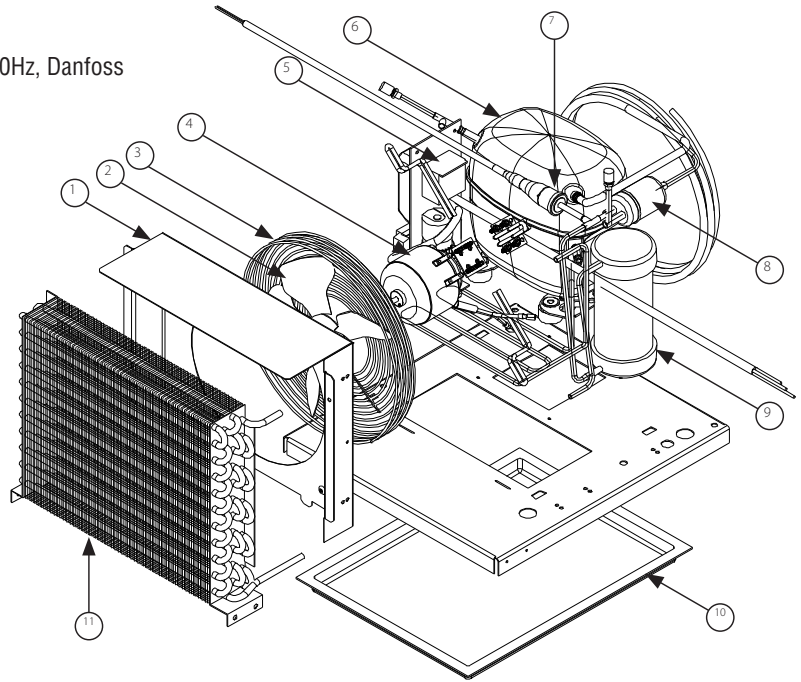

ASM-48 Condensing Unit Assembly 3/4 H.P.

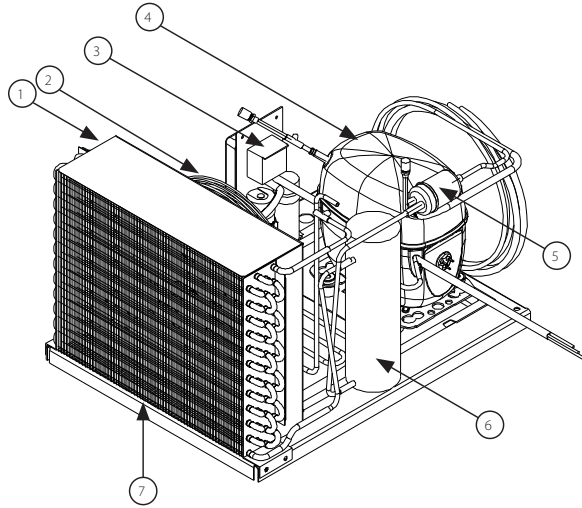

Key	Delfield Part #	Description
-	000-BN5-0036	Condensing Unit Assembly
1	026-C58-0032	Shroud, 3/4 HP condenser coil
2	2160019	Guard, fan, condenser, upright
3	3516442	Capacitor, start, run, assembly
4	3527021	Compressor, SC18MLX, 115V/60Hz, Danfoss
5	3516322	Filter dryer, (2) inlet, .25"
6	3516360	Tank, receiver
7	3516456	Coil, condenser, 3/4 HP
-	075-231-0031	Pan, condensate
-	3516433	Blade, fan 25°, 10", CW, upright
-	2162716	Motor, fan, 16W, 115V
-	000-282-009G	Control Assembly, ASM-48

ASM-60 Condensing Unit Assembly 1 H.P.

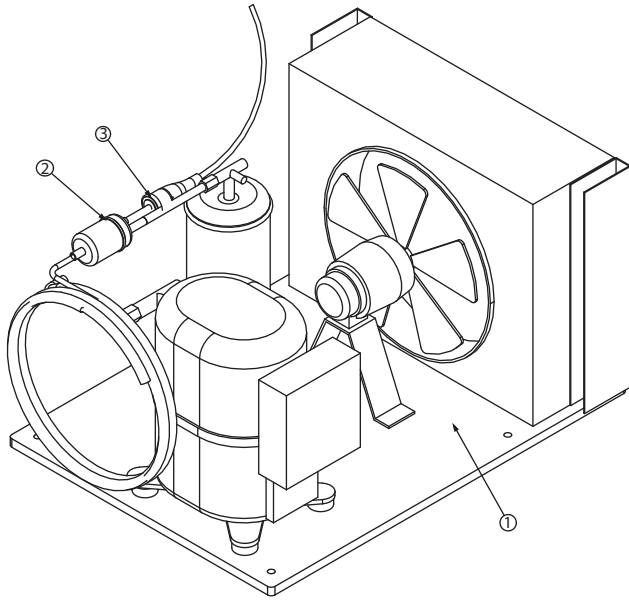

Key	Delfield Part #	Description
-	000-254-0005	Condensing Unit Assembly
1	3527008	Condensing Unit, 1HP
2	3516322	Filter dryer, (2) inlet, .25"
3	3516331	Switch, Hi Pressure
-	000-282-009H	Control Assembly, ASM-60

Replacement Parts

Part #	Description
2184182	Black Female Light Socket
3239598	Condensate Evap, 120V
3239669	Condensate Evap, 208V
000-282-009F	Control Assembly, ASM-36
000-282-009G	Control Assembly, ASM-48
000-282-009H	Control Assembly, ASM-60
3516101	Filter Dryer
3516247	High Pressure Control
2194755	Probe, 60" Lg
2194809	Probe, 118" Lg
2195088	Relay
2190154	Rocker Switch, Single
tbp60137	Rocker Switch, Double

Replacement Parts, continued

3rd Fan Assy Required
On ASM-60 Only

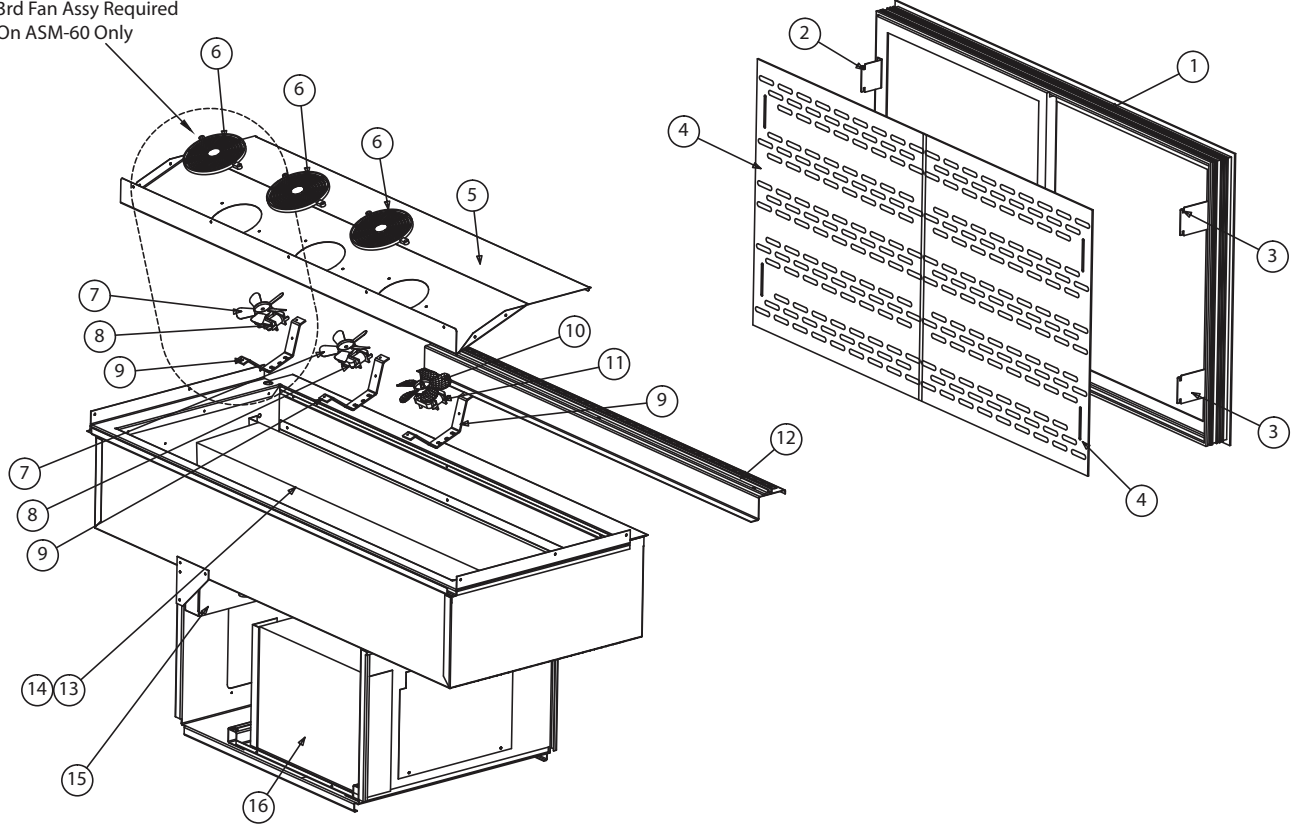

Key	ASM-36 Part #	ASM-48 Part #	ASM-60 Part #	Description
1	3239663	3239662	3239661	Sliding Door Set
	3239709	3239704	3239699	Bottom Track
	3239710	3239705	3239700	Bumper Gasket
	3239712	3239707	3239702	Spring
	3239708	3239703	3239698	Top Track
	3239711	3239706	3239701	Wiper Gasket
2	263-b4g-0041	263-b4g-0041	263-b4g-0041	3" Plexi Airduct Bracket
3	263-b4g-0040	263-b4g-0040	263-b4g-0040	3.75" Plexi Airduct Bracket
4	103-246-0043	103-246-0044	103-246-0045	Plexi Airduct Panel
5	019-0v1-0040	019-0v1-0041	019-0v1-0042	Fan Cover
6	3516173	3516173	3516173	Evaporator Fan Guard
7	3516172	3516172	3516172	CCW Clear Evaporator Fan Blade
8	2162691	2162691	2162691	CW Evaporator Fan Motor
9	031-264-0000	031-264-0000	031-264-0000	Evaporator Fan Motor Bracket
10	3517356	3517356	3517356	CW Black Evaporator Fan Blade
11	2162693	2162693	2162693	CCW Evaporator Fan Motor
12	327-b0v-0037	327-b0v-0036	327-b0v-0035	Sliding Door Track
13	3517374	3517375	3517376	Evaporator Coil
14	3517379	3517379	3517380	Expansion Valve, R404A
15	2195300	2195300	2195300	Ballast
16	000-bn5-0035	000-bn5-0036	000-254-0005	Condensing Unit Assembly

Replacement Parts, continued

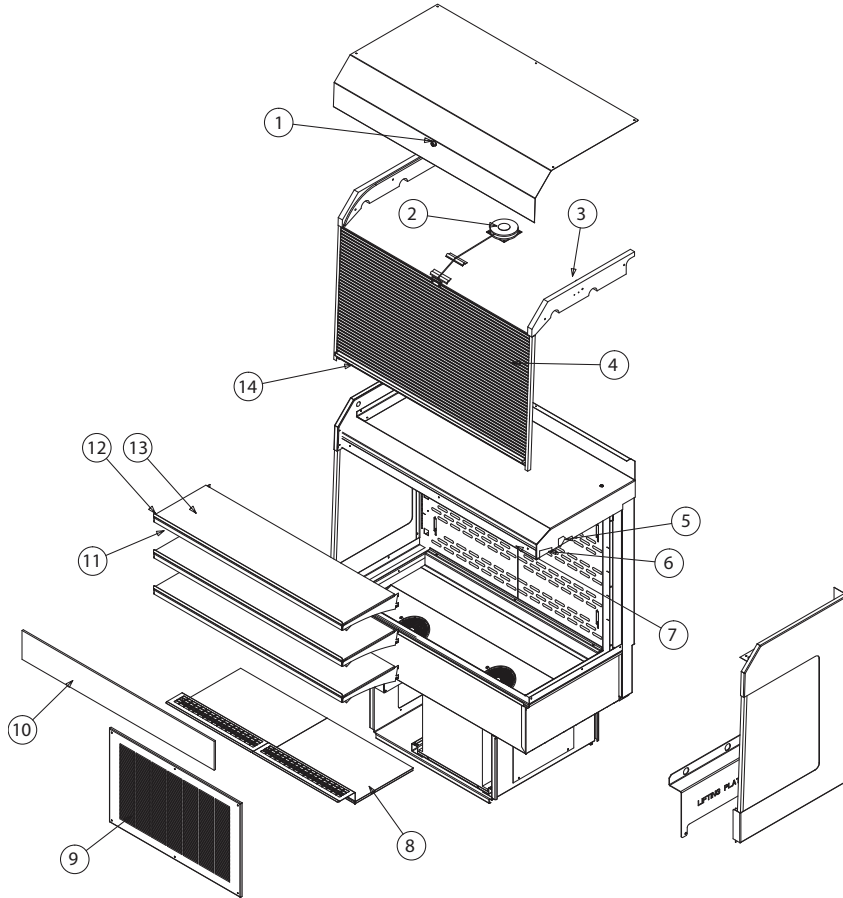

Key	ASM-36 Part #	ASM-48 Part #	ASM-60 Part #	Description
1	3239673	3239673	3239673	Door Lock
2	3235065	3235065	3235065	Security Cover Lifting Mech,
3	2195304	2195304	2195304	Roller Lever Switch
4	3235062	3235063	3235064	Cover Assembly, Includes Handles & Lifting Mech.
	3235068	3235068	3235068	Security Cover Slat
5	2194947	2194948	2194949	Fluorescent Light Fixture
6	1706117	1706117	1706117	Honeycomb Diffuser
7	2186849	2186850	2186851	Heater Wire
8	000-bx4-0040	000-bx4-0041	000-bx4-0042	Air Diffuser Pan Assembly
9	359-411-000k	359-411-000k	359-411-000k	Front Louvered Panel
10	3455639	3455640	3455641	Front Glass Deflector
11	2194947	2194948	2194949	Fluorescent Light Fixture
12	000-bx5-0030	000-bx5-0031	000-bx5-0032	Shelf Assembly
13	3455644	3455643	3455642	Shelf Glass
14	3235066	3235066	3235066	Security Cover Handle
	3235067	3235067	3235067	Recessed Handle Pocket
	3235069	3235069	3235069	Recessed Handle End Cap

Temperature Control Settings



Adjustments should be made by a service professional only. Contact the service department at Delfield +1 (989) 773-7981 or your local service agent for assistance. Delfield is not responsible for charges incurred while adjusting the temperature control.



The temp displayed on the control is the coil temperature not the box temperature.

Change Coil Temperature

1. Push the middle button until the coil temperature value is shown.
2. Push the upper or the lower button and select the new value.
Please make small incremental adjustments if a temperature adjustment is necessary.
3. Push the middle button again to conclude the setting.

Parameter	Screen Name	36"	48"	60"	Units	Parameter Description
Set Point, Coil Temperature	Cutout	26.1	29.66	25.1	F°	Reference point, can be cut-in or cut-out based on a positive or negative differential



Do not adjust other parameter values without contacting the Delfield service department at +1 (989) 773-7981.

Change Other Parameter Values

1. Push the upper button for a couple of seconds until a parameter r01 is shown.
2. Push the upper or the lower button and find that parameter screen name you want to change.
3. Push the middle button until the parameter value is shown.
4. Push the upper or the lower button and select the new value.
5. Push the middle button again to save the value.

Parameter	Screen Name	36"	48"	60"	Units	Parameter Description
Differential	r01	7	4.73	8.4	F°	A positive differential value gives the cut-in value, while a negative value creates a cut-out value
Unit Temperature	r05	1	1	1	F°	C=0/F=1. Celsius or Fahrenheit readout in display
Night Setback Value	r13	1.9	-7	1.9	F°	Allows for a warmer or colder set point with night curtain in down position
Defrost Method	d01	1	1	1		1=Electric or off-cycle
Defrost Stop Temperature	d02	46.4	49.5	51.4	F°	Temperature that stops defrost (defrost termination)
Interval Between Defrosts	d03	3	3	3	Hours	Time in between defrost

Standard Labor Guidelines To Repair Or Replace Parts On Delfield Equipment

Advice and recommendations given by Delfield Service Technicians do not constitute or guarantee any special coverage.

- A maximum of 1-hour is allowed to **diagnose a defective component**.
- A maximum of 1-hour is allowed for **retrieval of parts** not in stock.
- A maximum **travel distance** of 100 miles round trip and 2-hours will be reimbursed.
- Overtime, installation/start-up, normal control adjustments, general maintenance, glass breakage, freight damage, and/or correcting and end-user installation error will not be reimbursed under warranty unless pre-approved with a **Service Work Authorization** from Delfield. You must submit the number with the service claim.

Labor Of 1-Hour Is Allowed To Replace:

- Ballast/Light
- Circulating Fan Motor and Blade
- Compressor Start Components and Overload Protector
- Door Hinges, Locks, and Gaskets
- Evaporator/Condenser Fan Motor and Blade
- Microprocessor Control

Labor Of 2 Hours To Replace:

- Locate/Repair Leak

Labor Of 3 Hours To Replace:

- Condenser or Evaporator Coil
- Expansion Valve

Labor Of 4 Hours To Replace:

- Compressor

This includes recovery of refrigerant and leak check.

\$55.00 maximum reimbursement for refrigerant recovery (includes recovery machine, pump, torch, oil, flux, minor fittings, solder, brazing rod, nitrogen, or similar fees.)

Refrigerants:

- R404A A maximum of \$15.00/lb. or \$1.00/oz. will be reimbursed.

Notes





Mt. Pleasant, MI



Covington, TN

Thank you for choosing Delfield!

Help is a phone call away. Help our team of professional, courteous customer service reps by having your model number and serial number available at the time of your call (800) 733-8829.

Model: _____ S/N: _____

Installation Date: _____



For a list of Delfield's authorized parts depots, visit our website at www.delfield.com

Register your Delfield warranty online. Go to www.delfield.com under the service tab to complete.

