

ASM-P Series

Original Instructions Installation, Operation and Maintenance Manual

This manual is updated as new information and models are released. Visit our website for the latest manual.



Safety Notices

⚠ Warning

Read this manual thoroughly before operating, installing or performing maintenance on the equipment. Failure to follow instructions in this manual can cause property damage, injury or death.

⚠ DANGER

Do not lift the condensing unit by the refrigerant tubing or other components. These features will not support the condensing unit weight. Injury and unit damage may occur!

⚠ DANGER

Do not install or operate equipment that has been misused, abused, neglected, damaged, or altered/modified from that of original manufactured specifications.

⚠ DANGER

All utility connections and fixtures must be maintained in accordance with Local and national codes.

⚠ DANGER

Keep power cord AWAY from HEATED surfaces. DO NOT immerse power cord or plug in water. DO NOT let power cord hang over edge of table or counter.

⚠ Warning

Authorized Service Representatives are obligated to follow industry standard safety procedures, including, but not limited to, local/national regulations for disconnection / lock out / tag out procedures for all utilities including electric, gas, water and steam.

⚠ Warning

This appliance is not intended for use by persons (including children) with reduced physical, sensory or mental capabilities, or lack of experience and knowledge, unless they have been given supervision concerning use of the appliance by a person responsible for their safety. Do not allow children to play with this appliance.

⚠ Warning

Do not store or use gasoline or other flammable vapors or liquids in the vicinity of this or any other appliance. Never use flammable oil soaked cloths or combustible cleaning solutions, for cleaning.

⚠ Warning

This product contains chemicals known to the State of California to cause cancer and/or birth defects or other reproductive harm. Operation, installation, and servicing of this product could expose you to airborne particles of glasswool or ceramic fibers, crystalline silica, and/or carbon monoxide. Inhalation of airborne particles of glasswool or ceramic fibers is known to the State of California to cause cancer. Inhalation of carbon monoxide is known to the State of California to cause birth defects or other reproductive harm.

⚠ Warning

Do not use electrical appliances inside the food storage compartments of the appliance, unless they are of the type recommended by the manufacturer.

⚠ Warning

Use caution when handling metal surface edges of all equipment.

⚠ Warning

DO NOT touch refrigeration lines inside units; some may exceed temperatures of 200°F (93.3°C).

Note

Proper installation, care and maintenance are essential for maximum performance and trouble-free operation of your equipment. Visit our website www.wbtkitchenware.com for manual updates, translations, or contact information for service agents in your area.

Note

These appliances are intended to be used for commercial applications, for example in kitchens of restaurants, canteens, hospitals and in commercial enterprises such as bakeries, butcheries, etc., but not for continuous mass production of food.

Note

Climatic class 4 is defined as ambient conditions of 30°C and 55% relative humidity, according to ISO 23953-2.

Note

These appliances will operate within the marked rated voltage range without adjustment.

Note

This product utilizes Ecomate blowing agent methyl formate

Table of Contents

Section 1 General Information

Model Numbers	4
Serial Number Location	4
Warranty Information	4
Regulatory Certifications	4
Dimensioned Drawings	5

Section 2 Installation

Location	6
Weight of Equipment	7
Clearance Requirements.....	7
Dimensions	7
Electrical Service	8
Voltage	8
Fuse/Circuit Breaker	8
Ground Fault Circuit Interrupter	8
Rated Amperages, Horsepower, Voltage & Power Cord Chart.....	8
Installation Instructions	9
Prepare the Cabinet.....	9
Lower in the ASM	10
Construct an Air Duct	10
Plumbing.....	11
Leveling.....	11
Sliding Door Removal And Reinstall.....	11
Night & Security Cover Operations.....	11
Shelf Adjustments	11

Section 3 Operation

Operation.....	12
Temperature Control Settings.....	13
Change Set-point Temperature.....	13
Temperature Alarm.....	13

Section 4 Maintenance

Cleaning and Sanitizing Procedures.....	14
General.....	14
Interior Cleaning.....	14
Exterior Cleaning.....	15
Plexiglas, Including Baffles.....	15
Sliding Doors.....	15
Drain.....	15
Cleaning the Condenser Coil	15

Section 1

General Information

Model Numbers

This manual covers standard units only.

NOTE: For [custom](#) units, consult Manitowoc KitchenCare at 1-844-724-CARE.

Drop-In Air Screen Merchandisers
ASM-36P
ASM-48P

Serial Number Location

The serial number on all self-contained Drop-In Air Screen Merchandisers is located on the mechanical section wall.

Always have the serial number of your unit available when calling for parts or service.



Warranty Information

- Register your product for warranty.
- Verify warranty information.
- View and download a copy of your warranty.

At www.delfield.com/warranty

Regulatory Certifications

All models are certified by:

-  National Sanitation Foundation (NSF)
-  Underwriters Laboratories (UL)
-  Underwriters Laboratories of Canada (cUL)

Dimensioned Drawings

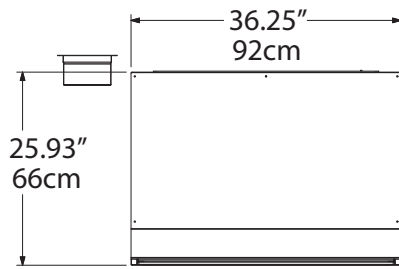

Plan View, ASM-36P

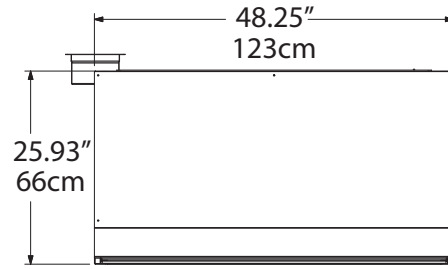

Plan View, ASM-48P

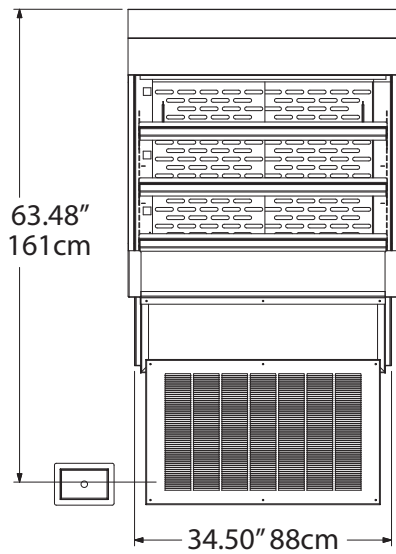

Elevation View, ASM-36P

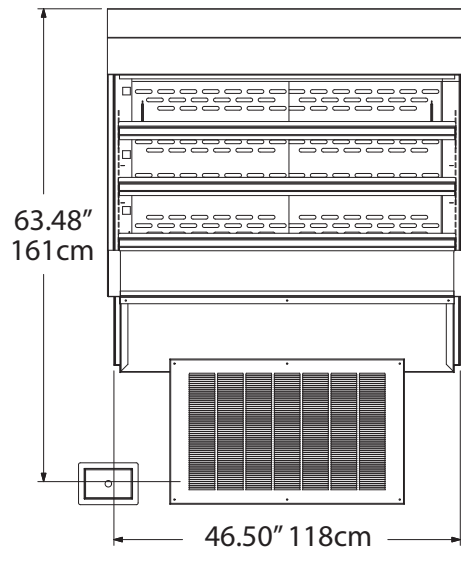

Elevation View, ASM-48P

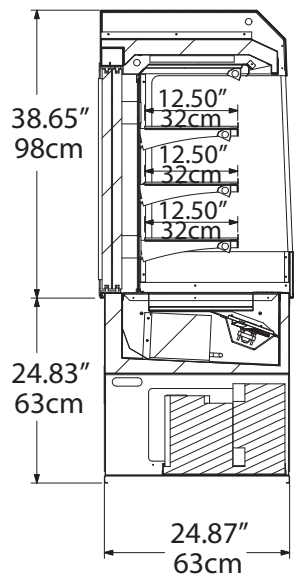

Left Section View,
ASM-36P, ASM-48P

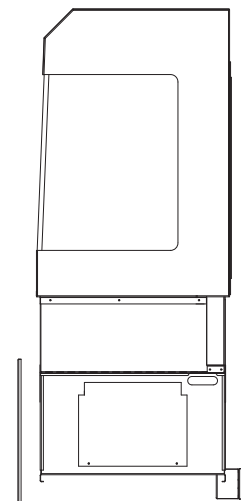

Right Side View,
ASM-36P, ASM-48P

Section 2 Installation

⚠ DANGER

Installation must comply with all applicable fire and health codes in your jurisdiction.

⚠ DANGER

Use appropriate safety equipment during installation and servicing.

⚠ Warning

Do not damage the refrigeration circuit when installing, maintaining or servicing the unit.

⚠ Caution

Do not position the air intake vent near steam or heat exhaust of another appliance.

NOTE

This symbol indicates the location of the equipotential bonding conductor connection.



NOTE

This symbol indicates a hot surface that can cause injury to persons.



Location

⚠ Warning

This equipment must be positioned so that the plug is accessible unless other means for disconnection from the power supply (e.g., circuit breaker or disconnect switch) is provided.

⚠ Warning

Adequate means must be provided to limit the movement of this appliance without depending on or transmitting stress to the electrical conduit or gas lines.

⚠ Warning

To avoid instability the installation area must be capable of supporting the combined weight of the equipment and product. Additionally the equipment must be level side to side and front to back.

⚠ Warning

This equipment is intended for indoor use only. Do not install or operate this equipment in outdoor areas.

⚠ Warning

Remove all removable panels before lifting and installing.

⚠ Warning

If a refrigerated base does not have a condensate evaporator supplied, you must connect the condensate line to a suitable drain. Otherwise, water will collect on the floor, causing a potentially hazardous situation.

⚠ Warning

Moisture collecting from improper drainage can create a slippery surface on the floor and a hazard to employees. It is the owners responsibility to provide a container or outlet for drainage.

The location selected for the equipment must meet the following criteria. If any of these criteria are not met, select another location.

- Units are intended for indoor use only.
- Unit is designed to maintain 36°F - 40°F at 80°F ambient room temperature (2°C - 4°C at 27°C) in 55% or lower relative humidity.
- Unit is NSF listed and designed for storage of pre-package foods.
- The location MUST be level, stable and capable of supporting the weight of the equipment.
- The location MUST be free from and clear of combustible materials.
- Equipment MUST be level both front to back and side to side.
- Position the equipment so it will not tip or slide.
- Proper air supply for ventilation is REQUIRED AND CRITICAL for safe and efficient operation. Refer to Clearance Requirements chart on page 7.
- Avoid hot corners and locations near stoves and ovens.

- Do not obstruct the flow of ventilation air. Make sure the air vents of the equipment are not blocked.
- Air movement in the room will adversely effect ASM refrigeration. Do not place the model near doors or air vents.
- Do not install the equipment directly over a drain. Steam rising up out of the drain will adversely affect operation, air circulation, and damage electrical / electronic components.

Weight of Equipment

Model	Weight
ASM-36P	425lbs (193kg)
ASM-48P	500lbs (227kg)

Clearance Requirements

⚠ DANGER
Minimum clearance requirements are the same for noncombustible locations as for combustible locations. The flooring under the appliance must be made of a noncombustible material.

⚠ DANGER
Risk of fire/shock. All minimum clearances must be maintained. Do not obstruct vents or openings.

Sides
1" (2.5cm)

- Keep the vents clean and free of obstruction.

Dimensions

Model	Length	Depth	Height
ASM-36P	36.25" (92cm)	25.93" (66cm)	63.48" (161cm)
ASM-48P	48.25" (123cm)	25.93" (66cm)	63.48" (161cm)

Model	Display Storage
ASM-36P	8.2ft ³
ASM-48P	11.3ft ³

These units are installed by placing them into the counter from above. The counter cutout sizes are as follows.

Model	Counter Cutout Dimensions
ASM-36P	35.13" x 25.50" (89cm x 65cm)
ASM-48P	47.13" x 25.50" (120cm x 65cm)

Model	Louver Cutout Dimensions
ASM-36P	28.00" x 17.00" (71cm x 42cm)
ASM-48P	28.00" x 17.00" (71cm x 42cm)

Model	Control Cutout Dimensions
ASM-36P	6.75" x 4.37" (17cm x 11cm)
ASM-48P	6.75" x 4.37" (17cm x 11cm)

Electrical Service

⚠ DANGER

Check all wiring connections, including factory terminals, before operation. Connections can become loose during shipment and installation.

⚠ Warning

This appliance must be grounded and all field wiring must conform to all applicable local and national codes. Refer to rating plate for proper voltage. It is the responsibility of the end user to provide the disconnect means to satisfy the authority having jurisdiction.

VOLTAGE

All electrical work, including wire routing and grounding, must conform to local, state and national electrical codes.

The following precautions must be observed:

- The equipment must be grounded.
- A separate fuse/circuit breaker must be provided for each unit.
- Check all green ground screws, cables and wire connections to verify they are tight before start-up.

FUSE/CIRCUIT BREAKER

A separate fuse/circuit breaker must be provided for each unit.

GROUND FAULT CIRCUIT INTERRUPTER

Ground Fault Circuit Interrupter (GFCI/GFI) protection is a system that shuts down the electric circuit (opens it) when it senses an unexpected loss of power, presumably to ground. Manitowoc does not recommend the use of GFCI/GFI circuit protection to energize our equipment. If code requires the use of a GFCI/GFI then you must follow the local code. The circuit must be dedicated, sized properly and there must be a panel GFCI/GFI breaker. We do not recommend the use of GFCI/GFI outlets to energize our equipment as they are known for more intermittent nuisance trips than panel breakers.

RATED AMPERAGES, HORSEPOWER, VOLTAGE & POWER CORD CHART

Model	ASM-36P	ASM-48P
Amps <small>(with condensate evap. / without condensate evap)</small>	5.0 / 3.7	11.8 / 7.7
HP	2 @ 1/3	2 @ 1/2
Voltage, Cycle, Phase	115V, 60Hz, 1Ph	115V, 60Hz, 1Ph
NEMA Plug	14-20P	14-20P
Cord Length	9ft (2.7m)	9ft (2.7m)

Refrigeration

Model	ASM-36P	ASM-48P
R-290 Charge	2 @ 5.3oz	2 @ 5.3oz
Cabinet Load BTU/Hour	4750	6250
System Capacity BTU/Hour	5278	6944

Installation Instructions

Installation Dimensions		
Cabinet Interior Minimum Dimensions		
Dimension	ASM-36P	ASM-48P
A	35.13" (89cm)	47.13" (120cm)
B	27.00" (69cm)	
C	28.00" (71cm)	
D	35.13" (89cm)	47.13" (120cm)
E	25.50" (65cm)	
F	Min 0.75" (19cm)	

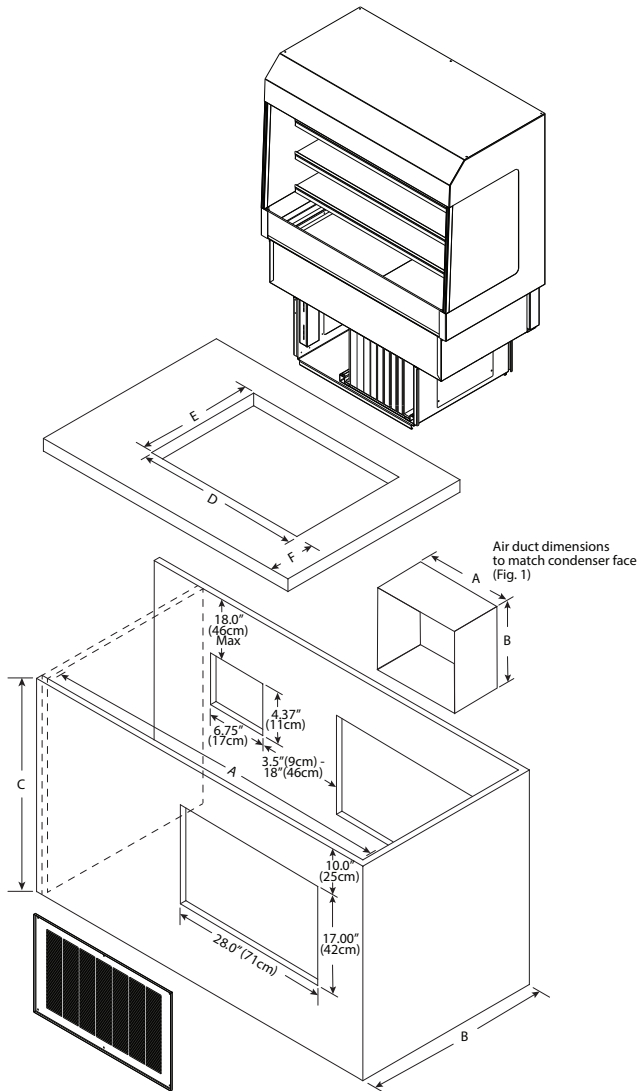

PREPARE THE CABINET

1. Install partitions between the Air Screen Merchandiser and other electrical appliances if they are located in the same cabinet. Partitions must fully extend front to back and top to bottom.
2. Install a GFCI receptacle a minimum of 14" (36cm) up from the cabinet bottom inside the partitions.
3. The unit requires airflow to the compressor. Two louvers are provided with each unit.

NOTE: Any restriction to the proper air flow will void the compressor warranty.

- Louver cut-outs are 28" x 17" (71cm x 42cm) cutouts.
- 143in² (923cm²) is required at both the intake and discharge.
- Louver cut-outs must extend to bottom of cabinet and align with condenser face.
- Install the louvers on the front and back of the cabinet.

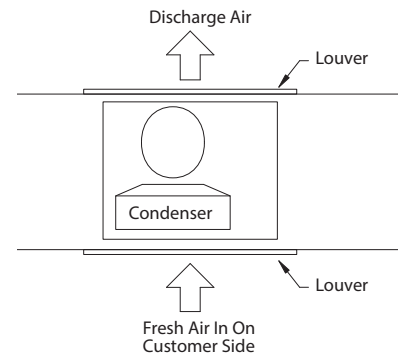

4. Cut a 6.75" x 4.37" (17cm x 11cm) hole in the base on the operator side for the control.
 - The maximum distance between counter top and the control cutout is 18" (46cm).
 - The distance between the louver and the control cutout must be between 3.50" (9cm) and 18" (46cm).

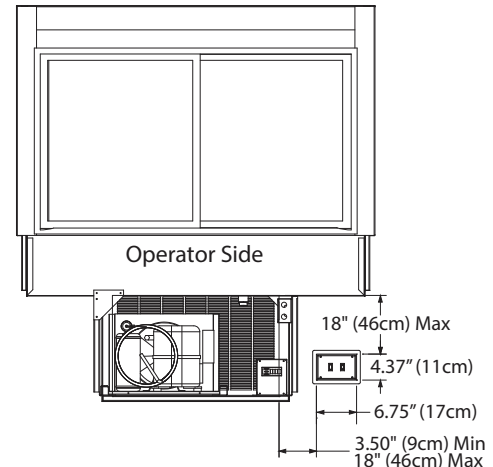

LOWER IN THE ASM

5. Remove the stainless steel pans in the bottom of the unit.
6. Remove the stainless steel pan clip rail below the door track.
7. Bolt in the lifting plates using the bolts located inside the tank that are installed in the lifting braces.
8. Slide two 1" steel pipes into the lifting plate holes. Place forklift forks under the pipes and clamp the forks and pipes in position.

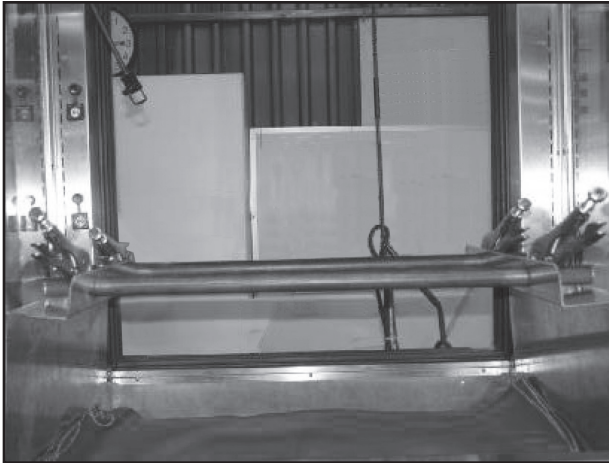

Lifting Plates and 1" Steel Pipes

9. Raise the unit high enough with the forklift to roll the base under the unit into position. Lower the ASM unit into the base using care to clear all of the flanges and screw heads.

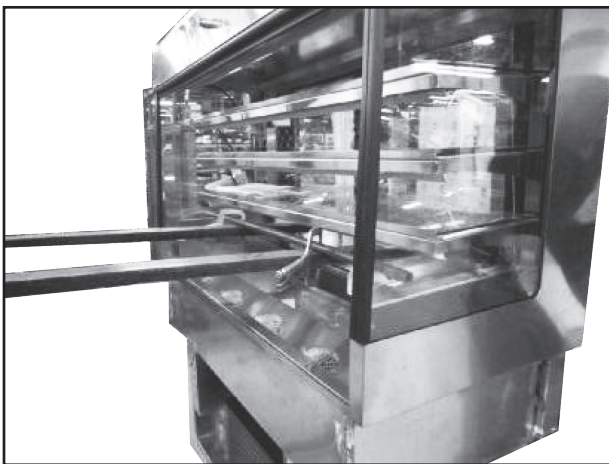

Lifted ASM

10. Remove the bolts and remove the lifting plates. Install plastic plugs in the bolt holes.
11. Install the stainless steel pan clip rail below the door track.
12. Install the stainless steel pans in the bottom on the unit making sure the turn down is engaged in the slot below the door track.
13. Install the sneeze guard glass in the clips and attach the end clip with two stainless steel self tapping screws.
14. Use gray silicone to finish the joint between the drop in unit and the top of the base.

CONSTRUCT AN AIR DUCT

15. Construct an air duct (not provided) connecting the condenser face to the louver. This will prevent recirculation of discharge air.

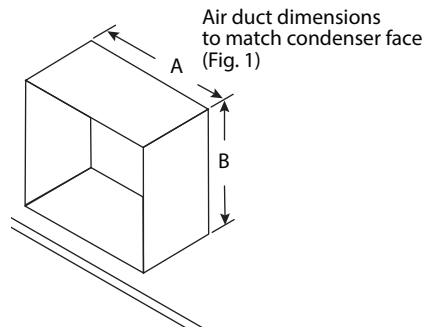

Air Duct Dimensions (Fig. 1)		
Dimension	ASM-36P	ASM-48P
A	10.5" (267mm)	13" (330mm)
B	11" (279mm)	11" (279mm)

Plumbing

Standard models will have a 1/2" drain which will need to be run to an appropriate floor drain. The drain will be stubbed inside the machine compartment.

⚠ Warning

Moisture collecting from improper drainage can create a slippery surface on the floor and a hazard to employees. It is the owner's responsibility to provide a container or outlet for drainage.

Leveling

After the cabinet has been placed in the desired location, cabinets with legs must be leveled. Level units from front to back and from side to side. Leveling will insure proper door operation and removal of condensate.

Sliding Door Removal And Reinstall

Sliding Door Removal

Open the door almost completely. Firmly grasp both sides of the door. Lift the door up and move it until it enters a notch and can be lifted higher. Tilt the bottom out without removing the top. Use the top to gently return the spring to the closed position. Remove the door from the top track.

Sliding Door Reinstall

There is a notch in the top inside corner of the door. Put the spring in the door's notch and move the spring to the open position. Put the top into the track and find the notch where the door can be lifted higher. Set bottom of the door into the track.

Night & Security Cover Operations

At the factory, the keys are taped to the display case. Pull the cover down, turn the key 90° to lock.

Shelf Adjustments

Display cases come with three tempered glass shelves that are adjustable in 1" increments.

Shelves can be slanted at three different angles. Remove the glass and unplug the light before adjusting the shelves.

Maximum weight for 36" (91cm) shelves is 25 lbs (11kg).

Maximum weight for 48" (122cm) shelves is 35 lbs (16kg).

⚠ Caution

Overloading shelves can damage equipment or cause bodily injury.

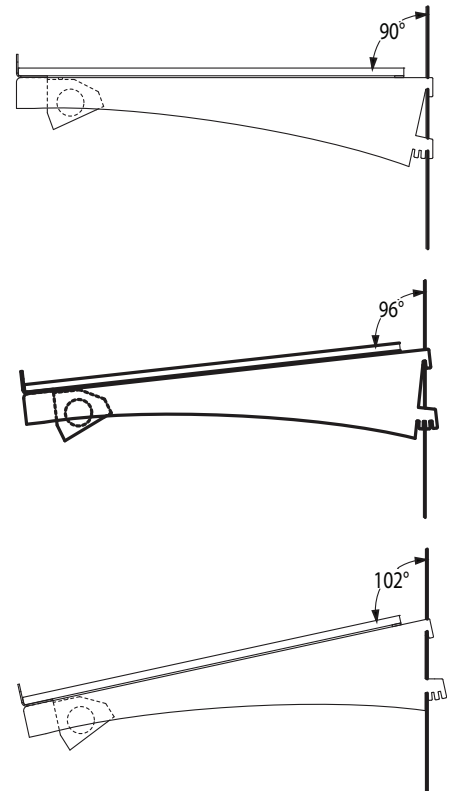

Section 3 Operation

⚠ DANGER

The on-site supervisor is responsible for ensuring that operators are made aware of the inherent dangers of operating this equipment.

⚠ DANGER

Do not operate any appliance with a damaged cord or plug. All repairs must be performed by a qualified service company.

⚠ DANGER

Never stand on the unit! They are not designed to hold the weight of an adult, and may collapse or tip if misused in this manner.

⚠ Warning

Do not contact moving parts.

⚠ Warning

All covers and access panels must be in place and properly secured, before operating this equipment.

⚠ Warning

Damp or wet hands may stick to cold surfaces.

⚠ Warning

Never use sharp objects or tools to remove ice or frost. Do not use mechanical devices or other means to accelerate the defrosting process.

⚠ Warning

The operator of this equipment is solely responsible for ensuring safe holding temperature levels for all food items. Failure to do so could result in unsafe food products for customers.

⚠ Warning

Do not block the supply and return air grills or the air space around the air grills. Keep plastic wrappings, paper, labels, etc. from being airborne and lodging in the grills. Failure to keep the air grills clear will result in unsatisfactory operation of the system.

Operation

An ON/OFF switch is located on the left side of the remote control panel. Simply turn the switch to ON to begin operation. There is a second ON/OFF switch on the right side of the remote control panel for the lights. The 3-way rocker switch has a position for On, Off and Eco Mode. Eco Mode is the factory default setting. Eco Mode toggles the lights on when the ASM Night Cover is open and off when the Night Cover is closed.

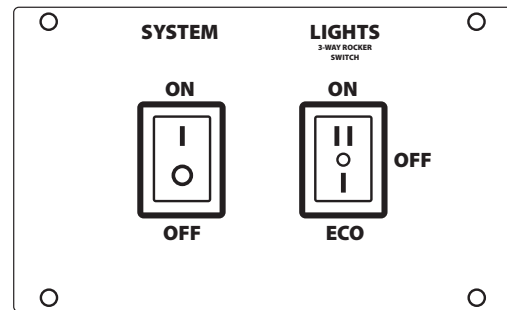

Delfield's Air Screen Merchandisers are designed to maintain an operational temperature of 36°F - 40°F at 80°F ambient room temperature (2°C - 4°C at 27°C) in 55% or lower relative humidity.

Note

If humidity is above 55%, condensation on the glass will be present.

Proper airflow is critical to maintaining temperature.

- Overloading the merchandiser, restricting the air flow, and continuous opening and closing of the doors will hinder the unit's ability to maintain operational temperatures.
- Do not interfere with the airflow by placing product over the air return openings.
- The Air Diffuser Pan Assembly must be properly in place at the bottom of the merchandising case, with the air return openings on the customer side.
- After cleaning or servicing the Front Deflector Glass, Honeycomb Diffuser and Airduct Plexiglas Panel must be replaced properly.

Temperature Control Settings

Note

The temp displayed on the control is the air temperature at the top of the display.



Press upper or lower right button.

- Display show actual set-point (blinking).
 - If buttons untouched for 3 seconds returns to normal.
- Increase set-point by pressing upper button. Max value depends on parameters in control.
- Decrease set-point by pressing lower button. Min value depends on parameters in control.
 - If buttons untouched for 3 seconds returns to normal and stores new set-point.

Press upper left button for 5 seconds.

- Start defrost.

Press lower left button for 5 seconds.

- Unit goes into stand-by mode.
 - The display will read Off, then a period.
- Press the lower left button again for 5 seconds.
 - The display will read On.
 - The unit will then start up in the defrost mode, and display will read dEF.

Temperature Alarm

The alarm will sound and flash HI or LO 90 minutes after the unit has reached its alarm temperature point or after any power interruption if the temperature is above or below the alarm set points. Air Screen Merchandisers are factory set to cut-out at 25.5°F to maintain 36°F - 40°F.

Parameter	36"	48"	Description
Set Point, Air Temperature	25.5°F	25.5°F	Reference point, the temperature in which the unit cuts-out cooling.

Section 4 Maintenance

⚠ DANGER

It is the responsibility of the equipment owner to perform a Personal Protective Equipment Hazard Assessment to ensure adequate protection during maintenance procedures.

⚠ DANGER

Failure to disconnect the power at the main power supply disconnect could result in serious injury or death. The power switch DOES NOT disconnect all incoming power.

⚠ DANGER

Disconnect electric power at the main power disconnect for all equipment being serviced. Observe correct polarity of incoming line voltage. Incorrect polarity can lead to erratic operation.

⚠ Warning

Never use sharp objects or tools to remove ice or frost. Do not use mechanical devices or other means to accelerate the defrosting process.

Cleaning and Sanitizing Procedures

⚠ Caution

Maintenance and servicing work other than cleaning as described in this manual must be done by an authorized service personnel.

GENERAL

⚠ Warning

When using cleaning fluids or chemicals, rubber gloves and eye protection (and/or face shield) must be worn.

Owners and operators are responsible for maintaining the equipment in accordance with the instructions in this manual. Maintenance procedures are not covered by the warranty.

Maintenance	Daily	Weekly	Monthly	After Prolonged Shutdown	At Start-Up
Interior	X			X	X
Exterior	X			X	X
Drain		X		X	X
Condenser Coil			X	X	X

INTERIOR CLEANING

Notice

When cleaning interior and exterior of unit, care should be taken to avoid the front power switch and the rear power cord. Keep water and/or cleaning solutions away from these parts.

Notice

Never use a high-pressure water jet for cleaning or hose down or flood interior or exterior of units with water. Do not use power cleaning equipment, steel wool, scrapers or wire brushes on stainless steel or painted surfaces.

The interior can be cleaned using soap and warm water. If this isn't sufficient, try ammonia and water or a nonabrasive liquid cleaner.

Preventing Blower Coil Corrosion

To help prevent corrosion of the blower coil, store all acidic items, such as pickles and tomatoes, in seal-able containers. Immediately wipe up all spills.

EXTERIOR CLEANING**Notice**

Never use an acid based cleaning solution on exterior panels! Many food products have an acidic content, which can deteriorate the finish. Be sure to clean the stainless steel surfaces of ALL food products.

Clean the area around the unit as often as necessary to maintain cleanliness and efficient operation.

Wipe gasket and surfaces with a damp cloth rinsed in water to remove dust and dirt from the outside of the unit. Always rub with the "grain" of the stainless steel to avoid marring the finish. If a greasy residue persists, use a damp cloth rinsed in a mild dish soap and water solution. Wipe dry with a clean, soft cloth.

Never use steel wool or abrasive pads for cleaning. Never use chlorinated, citrus based or abrasive cleaners.

Stainless steel exterior panels have a clear coating that is stain resistant and easy to clean. Products containing abrasives will damage the coating and scratch the panels. Daily cleaning may be followed by an application of stainless steel cleaner which will eliminate water spotting and fingerprints. Early signs of stainless steel breakdown are small pits and cracks. If this has begun, clean thoroughly and start to apply stainless steel cleaners in attempt to restore the steel.

PLEXIGLAS, INCLUDING BAFFLES

Wet a clean cloth with lukewarm water and dishwashing liquid. Apply only light pressure, rinse with clean water and blot dry with a damp chamois. For excessively dirty surfaces, rinse surface dirt off before washing. Fine scratches will disappear when you polish by hand with a plastic cleaner polish.

Notice

Never use window sprays, kitchen scouring compounds or solvents such as acetone, gasoline, benzene, alcohol, carbon tetrachloride or lacquer thinner to clean plexiglas.

SLIDING DOORS

Frequent, regular cleaning with a mild soap and water solution will keep the tracks free of foreign matter and will insure many years of service. The glass may be cleaned with one of the many commercial glass cleaners currently available.

DRAIN

Each unit has a drain located inside the unit that removes the condensation from the evaporator coil and routes it to an external condensate evaporator pan. Each drain can become loose or disconnected during normal use. If you notice water accumulation on the inside of the unit, be sure the drain tube is connected to the evaporator drain pan. If water is collecting underneath the unit, make sure the end of the drain tube is in the condensate evaporator. The leveling of the unit is important as the units are designed to drain properly when level. Be sure all drain lines are free of obstructions.

CLEANING THE CONDENSER COIL

In order to maintain proper refrigeration performance, the condenser fins must be cleaned of dust, dirt and grease regularly. It is recommended that this be done monthly. If conditions are such that the condenser is totally blocked in a month, the frequency of cleaning should be increased. Clean the condenser with a vacuum cleaner or stiff brush. If extremely dirty, a commercially available condenser cleaner may be required.

Failure to maintain a clean condenser coil can initially cause high temperatures and excessive run times. Continuous operation with a dirty or clogged condenser coil can result in compressor failure. Neglecting the condenser coil cleaning procedures will void any warranties associated with the compressor and cost to replace the compressor.



DELFIELD
980 SOUTH ISABELLA ROAD, MOUNT PLEASANT, MI 48858
800-733-8821
WWW.DELFIELD.COM



Welbilt offers fully-integrated kitchen systems and our products are backed by KitchenCare® aftermarket parts and service. Welbilt's portfolio of award-winning brands includes **Cleveland™**, **Convotherm®**, **Crem®**, **Delfield®**, **fitkitchen®**, **Frymaster®**, **Garland®**, **Kolpak®**, **Lincoln®**, **Manitowoc®**, **Merco®**, **Merrychef®** and **Multiplex®**.

Bringing innovation to the table • **welbilt.com**