

Drop Ins

**8100-EF, N8000, N8000N, N8000-R, N8100B,
N8100-BR, N8100-FA, N8200, N8200G, N8200-ST,
N8600, N8700-D, N8700-DESP, N8700-R, N8800**

Original Instructions Service Manual

This manual is updated as new information and models are released. Visit our website for the latest manual.



Safety Notices

⚠ Warning

Read this manual thoroughly before operating, installing or performing maintenance on the equipment. Failure to follow instructions in this manual can cause property damage, injury or death.

⚠ DANGER

Keep power cord AWAY from HEATED surfaces. DO NOT immerse power cord or plug in water. DO NOT let power cord hang over edge of table or counter.

⚠ DANGER

Do not lift the condensing unit by the refrigerant tubing or other components. These features will not support the condensing unit weight. Injury and unit damage may occur!

⚠ DANGER

Do not install or operate equipment that has been misused, abused, neglected, damaged, or altered/modified from that of original manufactured specifications.

⚠ DANGER

All utility connections and fixtures must be maintained in accordance with Local and national codes.

⚠ Warning

This appliance is not intended for use by persons (including children) with reduced physical, sensory or mental capabilities, or lack of experience and knowledge, unless they have been given supervision concerning use of the appliance by a person responsible for their safety. Do not allow children to play with this appliance.

⚠ Warning

Do not store or use gasoline or other flammable vapors or liquids in the vicinity of this or any other appliance. Never use flammable oil soaked cloths or combustible cleaning solutions, for cleaning.

⚠ Warning

Authorized Service Representatives are obligated to follow industry standard safety procedures, including, but not limited to, local/national regulations for disconnection / lock out / tag out procedures for all utilities including electric, gas, water and steam.

⚠ Warning

This product contains chemicals known to the State of California to cause cancer and/or birth defects or other reproductive harm. Operation, installation, and servicing of this product could expose you to airborne particles of glasswool or ceramic fibers, crystalline silica, and/or carbon monoxide. Inhalation of airborne particles of glasswool or ceramic fibers is known to the State of California to cause cancer. Inhalation of carbon monoxide is known to the State of California to cause birth defects or other reproductive harm.

⚠ Warning

Do not use electrical appliances or accessories other than those supplied by the manufacturer.

⚠ Warning

Use caution when handling metal surface edges of all equipment.

⚠ Warning

DO NOT touch refrigeration lines inside units; some may exceed temperatures of 200°F (93.3°C).

Note

Proper installation, care and maintenance are essential for maximum performance and trouble-free operation of your equipment. Visit our website www.mtwkitchencare.com for manual updates, translations, or contact information for service agents in your area.

Table of Contents

Section 1 General Information

Model Numbers	5
Serial Number Location	6
Warranty Information	6
Regulatory Certifications	6
Domestic Models.....	6
Export Models	6

Section 2 Installation

Location	8
Weight Of Equipment	8
Dimensions	10
Clearance Requirements	11
Cutout Installation Dimensions	12
Curved Drop-In Cutout Details.....	15
Drop-In Counter Installation	16
Ice Cooled Drop-In Units	16
Self-Contained Refrigerated Drop-In Units.....	17
Forced-Air Refrigerated Drop-In Units.....	19
Self-Contained Combo Hot/Cold Drop-In Units	21
Hot Food Well Drop-In Units	22
Electrical Service	23
Voltage	23
Ground Fault Circuit Interrupter	23
Electrical Specifications Chart	23
Refrigeration	25
Optional Auto Fill Installation	26
Applicable to N8600 & N8800 Models.....	26
Applicable to N8700 Models.....	27

Section 3 Operation

Product Quality in Cold Pans	29
8100-EF(N) Series Operation	30
Temperature Control & Display	30
Changing Display from Fahrenheit to Celsius on ERC112 Control	31
N8100B, N8100-BR & N8100NB Operation	32
N8100-FA Operation	33
N8200 & N8200-ST Operation	33
Operation N8200G	33
8600 Hot/Cold Series Operation	34
N8700-D, N8700N, N8700-R & N8800 Series Operation	35
N8700-DESP Operation	36

**Section 4
Maintenance**

Cleaning and Sanitizing Procedures.....37
 General..... 37
 Exterior Cleaning..... 38
 Cleaning the Condenser Coil 38
 N8100-FA Series Drain Maintenance..... 38

**Section 5
Troubleshooting**

Problem -> Cause -> Correction Chart.....39

**Section 6
Refrigeration**

R404A

Refrigerant Recovery / Evacuation & Recharging.....40
Charging Procedures40
System Contamination Clean-up41
Mild System Contamination Clean-Up Procedure42
Severe System Contamination Clean-Up Procedure42
Filter Driers43

**Section 7
Component Check Procedures**

Mechanical Refrigeration Control44
Electric/Solid State Refrigeration Control44
Unit Air Flow Design44
 Self-Contained Refrigerated Drop-In Units & Self-Contained Combo Hot/Cold Drop-In
 Units 44
 Forced-Air Refrigerated Drop-In Units..... 44

**Section 8
Wiring Diagrams**

Drop-In Series 8100-EF & 8100-EFN45
Export Drop-In Series 8100-EF-E & 8100-EFN-E.....47
Drop-In Series N8100B, N8100NB & N8100-BR48
Export Drop-In Series N8100B-E & N8100NB-E48
N8100-FA Series Models49
Drop-In Frost Tops Series N8200 & N8200-ST50
Drop-In Granite Cold Slabs Series N8200G50
Export Drop-In Frost Tops Series N8200-E51
Export Drop-In Granite Cold Slabs Series N8200G-E.....51
N8600 Series52
N8700D, N8700DESP, N8700-R & N8700N Series55
8700UM Series Models59
N8800 Series Models60

**Section 9
Replacement Procedures**

Plumbing.....62
Wiring.....62

Section 1

General Information

Model Numbers

8100-EF Series		
LiquiTec® Eutetic Fluid Refrigerated Cold Pans - R404A		
8118-EF	8132-EF	8145-EF
8159-EF	8172-EF	8186-EF
8100-EF-E Export Series		
LiquiTec® Eutetic Fluid Refrigerated Cold Pans - R404A		
8118-EF-E	8132-EF-E	8145-EF-E
8159-EF-E	8172-EF-E	8186-EF-E
8100-EFN Series		
LiquiTec® Slim Line Eutetic Fluid Refrigerated Cold Pans - R404A		
8148-EFN	8169-EFN	8191-EFN
8100-EFN-E Export Series		
LiquiTec® Slim Line Eutetic Fluid Refrigerated Cold Pans - R404A		
8148-EFN-E	8169-EFN-E	8191-EFN-E
N8000 Series		
Ice Cooled Cold Pans		
N8018	N8030	N8043
N8056	N8069	N8081
N8000N Series		
Narrow Ice Cooled Cold Pans		
N8046N	N8068N	
N8000-R Series		
Curved Ice Cooled Cold Pans		
N8044-R	N8059-R	N8076-R
N8094-R		
N8100B Series		
Self-Contained Mechanically Cooled Pans - R404A		
N8118B	N8130B	N8143B
N8156B	N8169B	N8181B
N8100B-E Export Series		
Self-Contained Mechanically Cooled Pans - R404A		
N8118B-E	N8130B-E	N8143B-E
N8100B-E Export Series		
Self-Contained Mechanically Cooled Pans - R134A		
N8156B-E	N8169B-E	
N8100BR Series		
Curved Self-Contained Mechanically Cooled Pans - R404A		
N8144-BR	N8159-BR	N8176-BR
N8194-BR		
N8100-FA Series		
Forced Air Drop-In Mechanically Cooled Cold Pans - R404A		
N8131-FA	N8144-FA	N8157-FA
N8169-FA	N8182-FA	
N8100NB Series		
Self-Contained Mechanically Cooled Pans Narrow Style - R404A		
N8146NB	N8168NB	
N8100NB-E Export Series		
Self-Contained Mechanically Cooled Pans Narrow Style - R404A		
N8146NB-E	N8168NB-E	

N8200 Series		
Self-Contained Frost Tops - R404A		
N8231	N8245	N8259
N8273	N8287	
N8200-E Export Series		
Self-Contained Frost Tops - R404A		
N8231-E	N8245-E	N8259-E
N8273-E	N8287-E	
N8200G Series		
Self-Contained Granite Cold Slabs		
N8231G	N8245G	N8259G
N8273G		
N8200G-E Export Series		
Self-Contained Granite Cold Slabs - R404A		
N8231G-E	N8245G-E	N8259G-E
N8200-ST Series		
Self-Contained Frost Tops - R404A		
N8230-ST	N8240-ST	N8256-ST
N8258-ST	N8275-ST	
N8600 Series		
Self Contained Combination Hot/Cold Food Wells - R404A		
N8630	N8643	N8656
N8669	N8681	
N8700D Series		
Individually Controlled Heated Food Wells		
N8717-D	N8731-D	N8745-D
N8759-D	N8773-D	N8787-D
N8700D-E Export Series		
Individually Controlled Heated Food Wells		
N8717-D-E	N8731-D-E	N8745-D-E
N8759-D-E	N8773-D-E	N8787-D-E
N8700DESP Series		
Individually Controlled Energy Savings Heated Food Wells		
N8717-DESP	N8731-DESP	N8745-DESP
N8759-DESP	N8773-DESP	N8787-DESP
N8700-D-ESP-E Export Series		
Individually Controlled Energy Savings Heated Food Wells		
N8717-D-ESP-E	N8731-D-ESP-E	N8745-D-ESP-E
N8759-D-ESP-E	N8773-D-ESP-E	N8787-D-ESP-E
N8700N Series		
Individually Controlled Heated Narrow Food Wells		
N8746ND	N8768N	N8768ND
N8700-R Series		
Curved Individually Controlled Heated Food Wells		
N8744-R	N8759-R	N8776-R
N8794-R		
N8800 Series		
Single Tank Electric Hot Food Wells		
N8831	N8845	N8859
N8873	N8887	
N8800-E Export Series		
Single Tank Electric Hot Food Wells		
N8831-E	N8845-E	N8859-E
N8873-E	N8887-E	

Serial Number Location

The serial number is listed on the serial tag. If applicable it will also list the refrigerant used and the amount of charge.

- The serial tag on self-contained refrigerated units is located near the condensing unit.
- The serial tag on ice cooled units and remote refrigerated units is on the outside bottom of the food well.
- On hot food pans and hot/cold combination pans, the serial tag is located on the back of the control raceway or remote panel.

Always have the serial number of your unit available when calling for parts or service.

Warranty Information

- Register your product for warranty,
- Verify warranty information,
- View and download a copy of your warranty, at www.delfield.com/warranty



Regulatory Certifications

DOMESTIC MODELS



All domestic models are certified by:

-  National Sanitation Foundation (NSF)

All domestic electrical models are certified by:



-  Underwriters Laboratories (UL)
-  Underwriters Laboratories of Canada (cUL)

Domestic N8700DESP models are also certified by:

-  Technical Inspection Association
-  European Conformity

EXPORT MODELS

All export models are certified by:

-  National Sanitation Foundation (NSF)
-  Technical Inspection Association
-  European Conformity

Section 2 Installation

⚠ DANGER

Installation must comply with all applicable fire and health codes in your jurisdiction.

⚠ DANGER

Use appropriate safety equipment during installation and servicing.

⚠ Warning

Remove all removable panels before lifting and installing.

⚠ Warning

If a refrigerated base does not have a condensate evaporator supplied, you must connect the condensate line to a suitable drain. Otherwise, water will collect on the floor, causing a potentially hazardous situation.

⚠ Warning

Moisture collecting from improper drainage can create a slippery surface on the floor and a hazard to employees. It is the owner's responsibility to provide a container or outlet for drainage.

⚠ Warning

Do not damage the refrigeration circuit when installing, maintaining or servicing the unit.

⚠ Warning

This equipment must be positioned so that the plug is accessible unless other means for disconnection from the power supply (e.g., circuit breaker or disconnect switch) is provided.

⚠ Warning

Adequate means must be provided to limit the movement of this appliance without depending on or transmitting stress to the electrical conduit.

⚠ Warning

To avoid instability the installation area must be capable of supporting the combined weight of the equipment and product. Additionally the equipment must be level side to side and front to back.

⚠ Warning

This equipment is intended for indoor use only. Do not install or operate this equipment in outdoor areas.

⚠ Caution

The units with LiquiTec technology cold pans contain a non-toxic eutectic fluid within a sealed inner liner. This fluid may leak if the tank is punctured so care must be taken when uncrating and setting in place. The eutectic fluid is non-toxic and may be flushed down a disposal drain. Units with a Eutectic Fluid Cold Pan require the same precautions. The fluid is NOT refillable and loss of fluid due to a puncture would cause irreparable damage. If the LiquiTec unit cold pans leak, immediately call the Delfield service department directly at 1-800-733-8821 not your local service agent.

⚠ Caution

Do not position the air intake vent near steam or heat exhaust of another appliance.

Location

The location selected for the equipment must meet the following criteria. If any of these criteria are not met, select another location.

- Units are intended for indoor use only.
- The location MUST be level, stable and capable of supporting the weight of the equipment.
- The location MUST be free from and clear of combustibile materials.
- Equipment MUST be level both front to back and side to side.
- Position the equipment so it will not tip or slide.
- Recommended air temperature is 41° - 86°F (5° - 30°C).
- Proper air supply for ventilation is REQUIRED AND CRITICAL for safe and efficient operation. Refer to Clearance Requirements chart on page 11.
- Do not obstruct the flow of ventilation air. Make sure the air vents of the equipment are not blocked.
- Do not install the equipment directly over a drain. Steam rising up out of the drain will adversely affect operation, air circulation, and damage electrical / electronic components.

Weight Of Equipment

Model	Ship Weight
8100-EF Series	
8118-EF	169lbs (77kg)
8132-EF	215lbs (98kg)
8145-EF	265lbs (120kg)
8159-EF	285lbs (130kg)
8172-EF	295lbs (134kg)
8186-EF	394lbs (179kg)
8100-EF-E Export Series	
8118-EF-E	169lbs (77kg)
8132-EF-E	215lbs (98kg)
8145-EF-E	265lbs (120kg)
8159-EF-E	285lbs (130kg)
8172-EF-E	295lbs (134kg)
8186-EF-E	394lbs (179kg)
8100-EFN Series	
8148-EFN	235lbs (107kg)
8169-EFN	285lbs (130kg)
8191-EFN	295lbs (134kg)
8100-EFN-E Export Series	
8148-EFN-E	235lbs (107kg)
8169-EFN-E	285lbs (130kg)
8191-EFN-E	295lbs (134kg)
N8000 Series	
N8018	38lbs (17kg)
N8030	84lbs (38kg)
N8043	110lbs (50kg)
N8056	139lbs (63kg)
N8069	160lbs (73kg)
N8081	197lbs (89kg)
N8000N Series	
N8046N	100lbs (45kg)
N8068N	120lbs (55kg)
N8000-R Series	
N8044-R	100lbs (45kg)
N8059-R	118lbs (53kg)
N8076-R	145lbs (65kg)
N8094-R	164lbs (74kg)
N8100B Series	
N8118B	100lbs (45kg)
N8130B	140lbs (64kg)
N8143B	173lbs (78kg)
N8156B	205lbs (93kg)
N8169B	225lbs (102kg)
N8181B	258lbs (117kg)
N8100B-E Export Series - R404A	
N8118B-E	100lbs (45kg)
N8130B-E	140lbs (64kg)
N8143B-E	173lbs (78kg)
N8100B-E Export Series - R134A	
N8156B-E	205lbs (93kg)
N8169B-E	225lbs (102kg)
N8100BR Series	
N8144-BR	161lbs (72kg)
N8159-BR	184lbs (83kg)
N8176-BR	233lbs (105kg)
N8194-BR	243lbs (109kg)

Model	Ship Weight
N8100-FA Series	
N8131-FA	168lbs (76kg)
N8144-FA	175lbs (79kg)
N8157-FA	225lbs (102kg)
N8169-FA	235lbs (107kg)
N8182-FA	406lbs (184kg)
N8100NB Series	
N8146NB	175lbs (80kg)
N8168NB	240lbs (109kg)
N8100NB-E Export Series	
N8146NB-E	175lbs (80kg)
N8168NB-E	240lbs (109kg)
N8200 Series	
N8231	142lbs (64kg)
N8245	168lbs (76kg)
N8259	193lbs (88kg)
N8273	209lbs (95kg)
N8287	239lbs (108kg)
N8200-E Export Series	
N8231-E	142lbs (64kg)
N8245-E	168lbs (76kg)
N8259-E	193lbs (88kg)
N8273-E	209lbs (95kg)
N8287-E	239lbs (108kg)
N8200G Series	
N8231G	219lbs (99kg)
N8245G	284lbs (129kg)
N8259G	338lbs (153kg)
N8273G	425lbs (193kg)
N8200G-E Export Series	
N8231G-E	219lbs (99kg)
N8245G-E	284lbs (129kg)
N8259G-E	338lbs (153kg)
N8200-ST Series	
N8230-ST	142lbs (64kg)
N8240-ST	168lbs (76kg)
N8256-ST	193lbs (88kg)
N8258-ST	209lbs (95kg)
N8275-ST	239lbs (108kg)
N8600 Series	
N8630	164lbs (74kg)
N8643	198lbs (90kg)
N8656	233lbs (106kg)
N8669	266lbs (121kg)
N8681	301lbs (137kg)
N8700D Series	
N8717-D	41lbs (19kg)
N8731-D	99lbs (45kg)
N8745-D	134lbs (61kg)
N8759-D	166lbs (75kg)
N8773-D	186lbs (84kg)
N8787-D	236lbs (107kg)
N8700D-E Export Series	
N8717-D-E	41lbs (19kg)
N8731-D-E	99lbs (45kg)
N8745-D-E	134lbs (61kg)
N8759-D-E	166lbs (75kg)
N8773-D-E	186lbs (84kg)
N8787-D-E	236lbs (107kg)

Model	Ship Weight
N8700DESP Series	
N8717-DESP	41lbs (19kg)
N8731-DESP	99lbs (45kg)
N8745-DESP	134lbs (61kg)
N8759-DESP	166lbs (75kg)
N8773-DESP	186lbs (84kg)
N8787-DESP	236lbs (107kg)
N8700-D-ESP-E Export Series	
N8717-D-ESP-E	41lbs (19kg)
N8731-D-ESP-E	99lbs (45kg)
N8745-D-ESP-E	134lbs (61kg)
N8759-D-ESP-E	166lbs (75kg)
N8773-D-ESP-E	186lbs (84kg)
N8787-D-ESP-E	236lbs (107kg)
N8700N Series	
N8746ND	100lbs (45kg)
N8768N	130lbs (59kg)
N8768ND	130lbs (59kg)
N8700-R Series	
N8744-R	99lbs (45kg)
N8759-R	134lbs (61kg)
N8776-R	166lbs (75kg)
N8794-R	186lbs (84kg)
N8800 Series	
N8831	100lbs (45kg)
N8845	136lbs (62kg)
N8859	158lbs (72kg)
N8873	195lbs (88kg)
N8887	224lbs (102kg)
N8800-E Export Series	
N8831-E	100lbs (45kg)
N8845-E	136lbs (62kg)
N8859-E	158lbs (72kg)
N8873-E	195lbs (88kg)
N8887-E	224lbs (102kg)

Dimensions

Model	12x20 Pans	Length	Depth	Height
8100-EF Series				
8118-EF	1	18.20" (46cm)	26" (66cm)	23.25" (59cm)
8132-EF	2	31.76" (81cm)		
8145-EF	3	45.32" (115cm)		
8159-EF	4	58.88" (150cm)		
8172-EF	5	72.44" (184cm)		
8186-EF	6	86" (218cm)		
8100-EF-E Export Series				
8118-EF-E	1	18.20" (46cm)	26" (66cm)	23.25" (59cm)
8132-EF-E	2	31.76" (81cm)		
8145-EF-E	3	45.32" (115cm)		
8159-EF-E	4	58.88" (150cm)		
8172-EF-E	5	72.44" (184cm)		
8186-EF-E	6	86" (218cm)		
8100-EFN Series				
8148-EFN	2	47.66" (121cm)	18" (46cm)	23.25" (59cm)
8169-EFN	3	69.22" (176cm)		
8191-EFN	4	90.78" (231cm)		
8100-EFN-E Export Series				
8148-EFN-E	2	47.66" (121cm)	18" (46cm)	23.25" (59cm)
8169-EFN-E	3	69.22" (176cm)		
8191-EFN-E	4	90.78" (231cm)		
N8000 Series				
N8018	1	18" (46cm)	26" (66cm)	10.75" (27cm)
N8030	2	30.75" (78cm)		
N8043	3	43.5" (110cm)		
N8056	4	56.25" (143cm)		
N8069	5	69" (175cm)		
N8081	6	81.75" (208cm)		
N8000N Series				
N8046N	2	46.75" (119cm)	18" (46cm)	10.75" (27cm)
N8068N	3	67.5" (171cm)		
N8000-R Series				
N8044-R	2	40.48" (103cm)	26.05" (66cm)	10.77" (27cm)
N8059-R	3	57.22" (145cm)		
N8076-R	4	73.68" (187cm)		
N8094-R	5	89.89" (228cm)		
N8100B Series				
N8118B	1	18" (46cm)	26" (66cm)	21.87" (56cm)
N8130B	2	30.75" (78cm)		
N8143B	3	43.5" (110cm)		
N8156B	4	56.25" (143cm)		
N8169B	5	69" (175cm)		
N8181B	6	81.75" (208cm)		
N8100B-E Export Series - R404A				
N8118B-E	1	18" (46cm)	26" (66cm)	21.87" (56cm)
N8130B-E	2	30.75" (78cm)		
N8143B-E	3	43.5" (110cm)		
N8100B-E Export Series - R134A				
N8156B-E	4	56.25" (143cm)	26" (66cm)	21.87" (56cm)
N8169B-E	5	69" (175cm)		
N8100BR Series				
N8144-BR	2	40.43" (103cm)	26.05" (66cm)	21.81" (55cm)
N8159-BR	3	57.22" (145cm)		
N8176-BR	4	73.68" (187cm)		
N8194-BR	5	89.86" (228cm)		

Model	12x20 Pans	Length	Depth	Height
N8100-FA Series				
N8131-FA	2	31.25" (79cm)	26.67" (68cm)	26.62" (68cm)
N8144-FA	3	44" (112cm)		
N8157-FA	4	56.75" (144cm)		
N8169-FA	5	69.5" (177cm)	26.67" (68cm)	28.62" (73cm)
N8182-FA	6	82.25" (209cm)		
N8100NB Series				
N8146NB	2	46.75" (119cm)	18" (46cm)	21.81" (55cm)
N8168NB	3	67.5" (171cm)		
N8100NB-E Export Series				
N8146NB-E	2	46.75" (119cm)	18" (46cm)	21.81" (55cm)
N8168NB-E	3	67.5" (171cm)		
N8200 Series				
N8231	NA	31.75" (81cm)	26" (66cm)	15.75" (40cm)
N8245	NA	45.63" (116cm)		
N8259	NA	59.5" (151cm)		
N8273	NA	73.38" (186cm)		
N8287	NA	87.25" (222cm)		
N8200-E Export Series				
N8231-E	NA	31.75" (81cm)	26" (66cm)	15.75" (40cm)
N8245-E	NA	45.63" (116cm)		
N8259-E	NA	59.5" (151cm)		
N8273-E	NA	73.38" (186cm)		
N8287-E	NA	87.25" (222cm)		
N8200G Series				
N8231G	NA	31.75" (81cm)	25.87" (66cm)	19" (48cm)
N8245G	NA	45.63" (116cm)		
N8259G	NA	59.5" (151cm)		
N8273G	NA	73.38" (186cm)		
N8200G-E Export Series				
N8231G-E	NA	31.75" (81cm)	25.87" (66cm)	19" (48cm)
N8245G-E	NA	45.63" (116cm)		
N8259G-E	NA	59.5" (151cm)		
N8200-ST Series				
N8230-ST	NA	29.60" (75cm)	22" (56cm)	15.70" (40cm)
N8240-ST	NA	39.70" (101cm)	29.60" (75cm)	
N8256-ST	NA	55.60" (141cm)	22" (56cm)	
N8258-ST	NA	57.60" (146cm)	29.60"	
N8275-ST	NA	75.50" (192cm)	(75cm)	
N8600 Series				
N8630	2	30.75" (78cm)	26" (66cm)	23.75" (60cm)
N8643	3	43.5" (110cm)		
N8656	4	56.25" (143cm)		
N8669	5	69" (175cm)		
N8681	6	81.75" (208cm)		
N8700D Series				
N8717-D	1	17.88" (45cm)	26" (66cm)	9.09" (23cm)*
N8731-D	2	31.75" (81cm)		
N8745-D	3	45.63" (116cm)		
N8759-D	4	59.5" (151cm)		
N8773-D	5	73.38" (186cm)		
N8787-D	6	87.25" (222cm)		

*14" Overall height including drain connection

Model	12x20 Pans	Length	Depth	Height
N8700D-E Export Series				
N8717-D-E	1	17.88" (45cm)	26" (66cm)	9.09" (23cm)*
N8731-D-E	2	31.75" (81cm)		
N8745-D-E	3	45.63" (116cm)		
N8759-D-E	4	59.5" (151cm)		
N8773-D-E	5	73.38" (186cm)		
N8787-D-E	6	87.25" (222cm)		
*14" Overall height including drain connection				
N8700DESP Series				
N8717-DESP	1	17.89" (45cm)	26" (66cm)	7.83" (20cm)*
N8731-DESP	2	31.76" (81cm)		
N8745-DESP	3	45.63" (116cm)		
N8759-DESP	4	59.50" (151cm)		
N8773-DESP	5	73.37" (186cm)		
N8787-DESP	6	87.24" (222cm)		
*14" Overall height including drain connection				
N8700-D-ESP-E Export Series				
N8717-D-ESP-E	1	17.89" (45cm)	26" (66cm)	7.83" (20cm)*
N8731-D-ESP-E	2	31.76" (81cm)		
N8745-D-ESP-E	3	45.63" (116cm)		
N8759-D-ESP-E	4	59.50" (151cm)		
N8773-D-ESP-E	5	73.37" (186cm)		
N8787-D-ESP-E	6	87.24" (222cm)		
*14" Overall height including drain connection				
N8700N Series				
N8746ND	2	45.61" (116cm)	15.87" (40cm)	9.09" (23cm)*
N8768N	3	67.48" (172cm)		
N8768ND	3	67.48" (172cm)		
*14" Overall height including drain connection				
N8700-R Series				
N8744-R	2	40.48" (103cm)	26.05" (66cm)	9.09" (23cm)*
N8759-R	3	57.22" (145cm)	26.05" (66cm)	
N8776-R	4	73.68" (187cm)	26" (66cm)	
N8794-R	5	89.80" (228cm)	25.91" (66cm)	
*14" Overall height including drain connection				
N8800 Series				
N8831	2	31.75" (81cm)	26" (66cm)	11" (28cm)
N8845	3	45.63" (116cm)		
N8859	4	59.5" (151cm)		
N8873	5	73.38" (186cm)		
N8887	6	87.25" (222cm)		
N8800-E Export Series				
N8831-E	2	31.75" (81cm)	26" (66cm)	11" (28cm)
N8845-E	3	45.63" (116cm)		
N8859-E	4	59.5" (151cm)		
N8873-E	5	73.38" (186cm)		
N8887-E	6	87.25" (222cm)		

Clearance Requirements

⚠ DANGER

Minimum clearance requirements are the same for noncombustible locations as for combustible locations. The flooring under the appliance must be made of a noncombustible material.

⚠ DANGER

Risk of fire/shock. All minimum clearances must be maintained. Do not obstruct vents or openings.

Heated & Combination Hot/Cold Food Wells Bottom & Side Clearance
3" (76mm)
Cooled Pans, Frost Tops & Granite Cold Slabs Clearance
0" (0cm)

- Keep the vents clean and free of obstruction.

Cutout Installation Dimensions

Model	Counter Cutout Dimensions	Control Panel Cutout Dimensions
8100-EF Series		
8118-EF	17" x 25" (43cm x 64cm)	NA
8132-EF	30.75" x 25" (78cm x 64cm)	
8145-EF	44.25" x 25" (112cm x 64cm)	
8159-EF	57.87" x 25" (147cm x 64cm)	
8172-EF	71.5" x 25" (182cm x 64cm)	
8186-EF	85" x 25" (216cm x 64cm)	
8100-EF-E Export Series		
8118-EF-E	17" x 25" (43cm x 64cm)	NA
8132-EF-E	30.75" x 25" (78cm x 64cm)	
8145-EF-E	44.25" x 25" (112cm x 64cm)	
8159-EF-E	57.87" x 25" (147cm x 64cm)	
8172-EF-E	71.5" x 25" (182cm x 64cm)	
8186-EF-E	85" x 25" (216cm x 64cm)	
8100-EFN Series		
8148-EFN	46.88" x 17.25" (119cm x 44cm)	NA
8169-EFN	68.5" x 17.25" (174cm x 44cm)	
8191-EFN	90" x 17.25" (229cm x 44cm)	
8100-EFN-E Export Series		
8148-EFN-E	46.88" x 17.25" (119cm x 44cm)	NA
8169-EFN-E	68.5" x 17.25" (174cm x 44cm)	
8191-EFN-E	90" x 17.25" (229cm x 44cm)	
N8000 Series		
N8018	17" x 25" (43cm x 64cm)	NA
N8030	29.75" x 25" (76cm x 64cm)	
N8043	42.5" x 25" (108cm x 64cm)	
N8056	55.25" x 25" (140cm x 64cm)	
N8069	68" x 25" (173cm x 64cm)	
N8081	80.75" x 25" (205cm x 64cm)	

Model	Counter Cutout Dimensions	Control Panel Cutout Dimensions
N8000N Series		
N8046N	45.75" x 17" (116cm x 43cm)	NA
N8068N	66.50" x 17" (169cm x 43cm)	
N8000-R Series		
N8044-R	See drawing on page 15	NA
N8059-R		
N8076-R		
N8094-R		
N8100B Series		
N8118B	17" X 25" (43cm x 64cm)	NA
N8130B	29.75" x 25" (76cm x 64cm)	
N8143B	42.50" X 25" (108cm x 64cm)	
N8156B	55.25" x 25" (140cm x 64cm)	
N8169B	68" X 25" (173cm x 64cm)	
N8181B	80.75" x 25" (205cm x 64cm)	
N8100B-E Export Series - R404A		
N8118B-E	17" X 25" (43cm x 64cm)	NA
N8130B-E	29.75" x 25" (76cm x 64cm)	
N8143B-E	42.50" X 25" (108cm x 64cm)	
N8100B-E Export Series - R134A		
N8156B-E	55.25" x 25" (140cm x 64cm)	NA
N8169B-E	68" X 25" (173cm x 64cm)	
N8100BR Series		
N8144-BR	See drawing on page 15	NA
N8159-BR		
N8176-BR		
N8194-BR		
N8100-FA Series		
N8131-FA	30.25" x 25.5" (77cm x 65cm)	NA
N8144-FA	43" x 25.5" 109cm x 65cm)	
N8157-FA	55.75" x 25.5" (142cm x 65cm)	
N8169-FA	68.5" x 25.5" 174cm x 65cm)	
N8182-FA	81.25" x 25.5" (206cm x 65cm)	
N8100NB Series		
N8146NB	45.75" x 17" (116cm x 43cm)	NA
N8168NB	66.5" x 17" (169cm x 43cm)	

Model	Counter Cutout Dimensions	Control Panel Cutout Dimensions
N8100NB-E Export Series		
N8146NB-E	45.75" x 17" (116cm x 43cm)	NA
N8168NB-E	66.5" x 17" (169cm x 43cm)	
N8200 Series		
N8231	30.75" x 25" (78cm x 64cm)	NA
N8245	44.63" x 25" (113cm x 64cm)	
N8259	58.50" x 25" (149cm x 64cm)	
N8273	72.38" x 25" (184cm x 64cm)	
N8287	86.25" x 25" (219cm x 64cm)	
N8200-E Export Series		
N8231-E	30.75" x 25" (78cm x 64cm)	NA
N8245-E	44.63" x 25" (113cm x 64cm)	
N8259-E	58.50" x 25" (149cm x 64cm)	
N8273-E	72.38" x 25" (184cm x 64cm)	
N8287-E	86.25" x 25" (219cm x 64cm)	
N8200G Series		
N8231G	30.75" X 25" (78cm x 64cm)	NA
N8245G	44.63" x 25" (113cm x 64cm)	
N8259G	58.5" x 25" (149cm x 64cm)	
N8273G	72.38" x 25" (184cm x 64cm)	
N8200G-E Export Series		
N8231G-E	30.75" X 25" (78cm x 64cm)	NA
N8245G-E	44.63" x 25" (113cm x 64cm)	
N8259G-E	58.5" x 25" (149cm x 64cm)	
N8200-ST Series		
N8230-ST	28.60" x 21.10" (73cm x 54cm)	NA
N8240-ST	38.65" x 28.75" (98cm x 73cm)	
N8256-ST	54.60" x 21.10" (139cm x 54cm)	
N8258-ST	56.60" x 28.75" (144cm x 73cm)	
N8275-ST	74.50" x 28.75" (189cm x 73cm)	

Model	Counter Cutout Dimensions	Control Panel Cutout Dimensions
N8600 Series		
N8630	29.75" X 25" (76cm x 64cm)	12.25" x 4.25" x 7" (31cm x 11cm x 18cm)
N8643	42.50" x 25" (108cm x 64cm)	
N8656	55.25" x 25" (140cm x 64cm)	
N8669	68" x 25" (173cm x 64cm)	
N8681	80.75" x 25" (205cm x 64cm)	
N8700 Series		
N8717-D	16.88" X 25" (43cm x 64cm)	7" x 4.62" x 7" (18cm x 12cm x 18cm)
N8731-D	30.75" x 25" (78cm x 64cm)	10.31" x 4.62" x 7" (26cm x 12cm x 18cm)
N8745-D	44.62" x 25" (113cm x 64cm)	14.5" x 4.62" x 7" (37cm x 12cm x 18cm)
N8759-D	58.5" x 25" (149cm x 64cm)	18.69" x 4.62" x 7" (47cm x 12cm x 18cm)
N8773-D	72.37" x 25" (184cm x 64cm)	22.88" x 4.62" x 7" (58cm x 12cm x 18cm)
N8787-D	86.25" x 25" (219cm x 64cm)	27" x 4.62" x 7" (69cm x 12cm x 18cm)
N8700-E Export Series		
N8717-D-E	16.88" X 25" (43cm x 64cm)	7" x 4.62" x 7" (18cm x 12cm x 18cm)
N8731-D-E	30.75" x 25" (78cm x 64cm)	10.31" x 4.62" x 7" (26cm x 12cm x 18cm)
N8745-D-E	44.62" x 25" (113cm x 64cm)	14.5" x 4.62" x 7" (37cm x 12cm x 18cm)
N8759-D-E	58.5" x 25" (149cm x 64cm)	18.69" x 4.62" x 7" (47cm x 12cm x 18cm)
N8773-D-E	72.37" x 25" (184cm x 64cm)	22.88" x 4.62" x 7" (58cm x 12cm x 18cm)
N8787-D-E	86.25" x 25" (219cm x 64cm)	27" x 4.62" x 7" (69cm x 12cm x 18cm)
N8700DESP Series		
N8717-DESP	16.87" X 25" (43cm x 64cm)	5" x 6.88" x 7.50" (13cm x 17cm x 19cm)
N8731-DESP	30.75" x 25" (78cm x 64cm)	5" x 11.88" x 7.50" (13cm x 30cm x 19cm)
N8745-DESP	44.62" x 25" (113cm x 64cm)	5" x 17.38" x 7.50" (13cm x 44cm x 19cm)
N8759-DESP	58.50" x 25" (149cm x 64cm)	5" x 22.88" x 7.50" (13cm x 58cm x 19cm)
N8773-DESP	72.37" x 25" (184cm x 64cm)	5" x 28.38" x 7.50" (13cm x 72cm x 19cm)
N8787-DESP	86.25" x 25" (219cm x 64cm)	5" x 33.88" x 7.50" (13cm x 86cm x 19cm)

Model	Counter Cutout Dimensions	Control Panel Cutout Dimensions
N8700-D-ESP-E Export Series		
N8717-D-ESP-E	16.87" X 25" (43cm x 64cm)	5" x 6.88" x 7.50" (13cm x 17cm x 19cm)
N8731-D-ESP-E	30.75" x 25" (78cm x 64cm)	5" x 11.88" x 7.50" (13cm x 30cm x 19cm)
N8745-D-ESP-E	44.62" x 25" (113cm x 64cm)	5" x 17.38" x 7.50" (13cm x 44cm x 19cm)
N8759-D-ESP-E	58.50" x 25" (149cm x 64cm)	5" x 22.88" x 7.50" (13cm x 58cm x 19cm)
N8773-D-ESP-E	72.37" x 25" (184cm x 64cm)	5" x 28.38" x 7.50" (13cm x 72cm x 19cm)
N8787-D-ESP-E	86.25" x 25" (219cm x 64cm)	5" x 33.88" x 7.50" (13cm x 86cm x 19cm)
N8700N Series		
N8746ND	44.62" x 15.0" (113cm x 38cm)	10.31" x 4.62" x 7" (26cm x 12cm x 18cm)
N8768N	66.50" x 15.0" (169cm x 38cm)	14.50" x 4.62" x 7" (37cm x 12cm x 18cm)
N8768ND	66.50" x 15.0" (169cm x 38cm)	14.50" x 4.62" x 7" (37cm x 12cm x 18cm)
N8700-R Series		
N8744-R	See drawing on page 15	10.31" x 4.62" x 7" (26cm x 12cm x 18cm)
N8759-R	See drawing on page 15	14.5" x 4.62" x 7" (37cm x 12cm x 18cm)
N8776-R	See drawing on page 15	18.69" x 4.62" x 7" (47cm x 12cm x 18cm)
N8794-R	See drawing on page 15	22.88" x 4.62" x 7" (58cm x 12cm x 18cm)
N8800 Series		
N8831	30.75" X 25" (78cm x 64cm)	12.25" x 4.25" x 7" (31cm x 11cm x 18cm)
N8845	44.63" x 25" (113cm x 64cm)	
N8859	58.5" x 25" (149cm x 64cm)	
N8873	72.38" x 25" (184cm x 64cm)	
N8887	86.25" x 25" (219cm x 64cm)	
N8800-E Export Series		
N8831-E	30.75" X 25" (78cm x 64cm)	12.25" x 4.25" x 7" (31cm x 11cm x 18cm)
N8845-E	44.63" x 25" (113cm x 64cm)	
N8859-E	58.5" x 25" (149cm x 64cm)	
N8873-E	72.38" x 25" (184cm x 64cm)	
N8887-E	86.25" x 25" (219cm x 64cm)	

CURVED DROP-IN CUTOUT DETAILS

2 pan standard curved drop-in cutout detail for models:

- N8044-R
- N8144-BR
- N8744-R

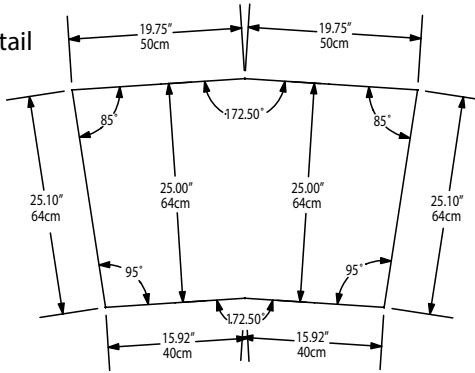

3 pan standard curved drop-in cutout detail for models:

- N8059-R
- N8159-BR
- N8759-R

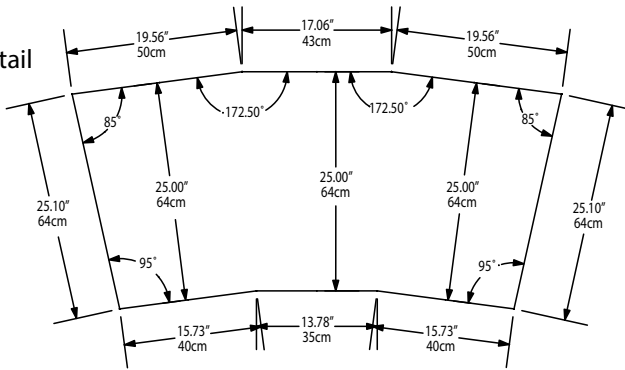

4 pan standard curved drop-in cutout detail for models:

- N8076-R
- N8176-BR
- N8776-R

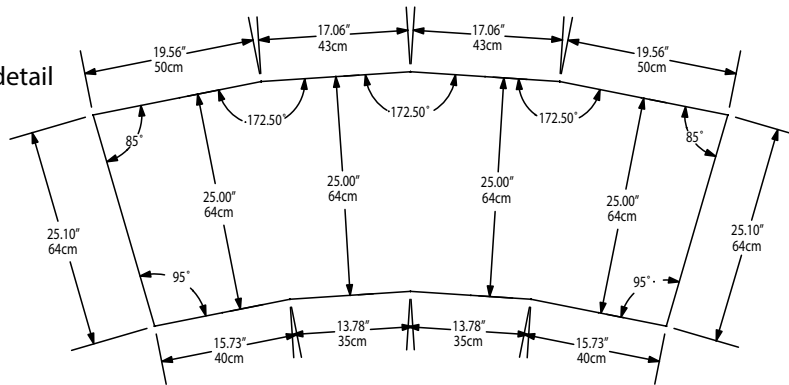

5 pan standard curved drop-in cutout detail or models:

- N8094-R
- N8194-BR
- N8794-R

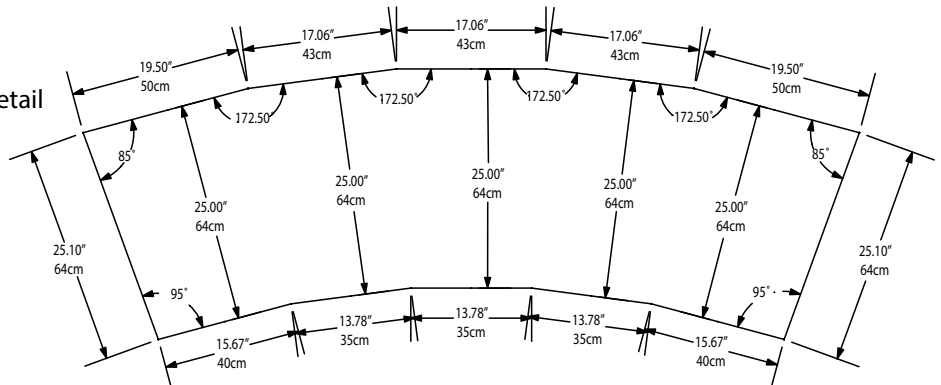

Drop-In Counter Installation

ICE COOLED DROP-IN UNITS

N8000, N8000N, N8000-R

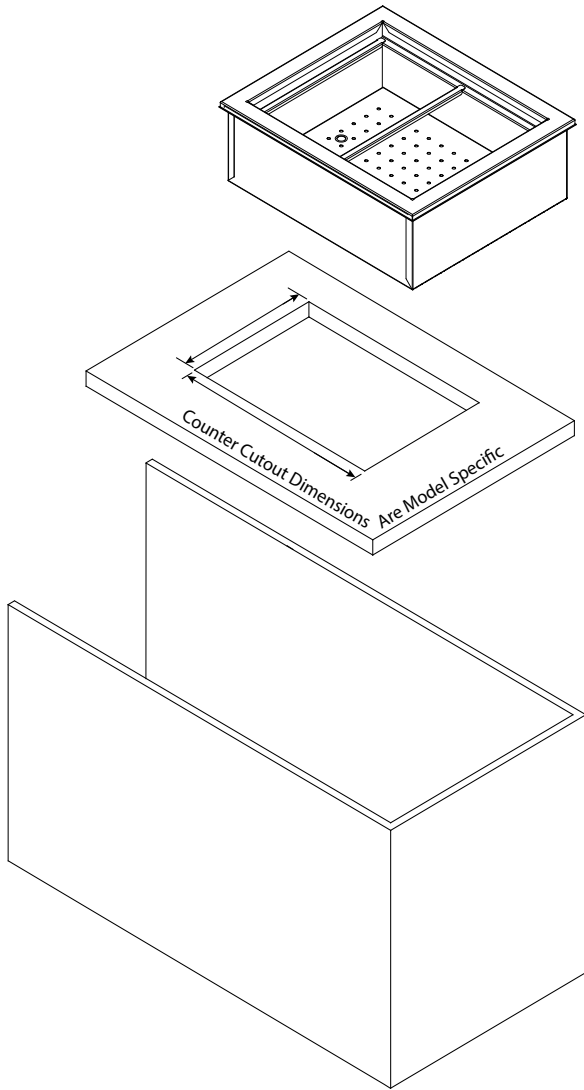

1. Place the ice cooled drop-in unit through the counter cutout.
2. A gasket is installed in the flange of each unit. The weight of the unit on the gasket forms a seal preventing liquids from seeping into the cut-out opening.
3. The 1" diameter drain on N8000, N8000N, N8000-R models is shipped loose and must be connected during installation.
 - A. Provided 1" (25mm) drain, nut and washer must be field installed to an appropriate container or floor drain following local code requirements. Sinks come standard with 1-1/2" basket strainer assemblies.



- B. Remove/drill foam out of drain hole.

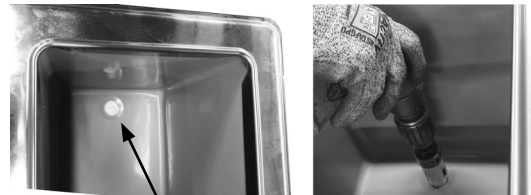

- C. Apply thin ring of plumbers putty around the drain.
 - D. From the inside drop the drain into the drain hole.



- E. From the outside secure the drain with the washer and nut.



- F. Tighten the nut with channel locks, use a fork to hold the drain in place if necessary.
 - G. Clean up excess plumbers putty.

SELF-CONTAINED REFRIGERATED DROP-IN UNITS
8100-EF(N), N8100B, N8100-BR, N8100NB, N8200,
N8200G, N8200-ST

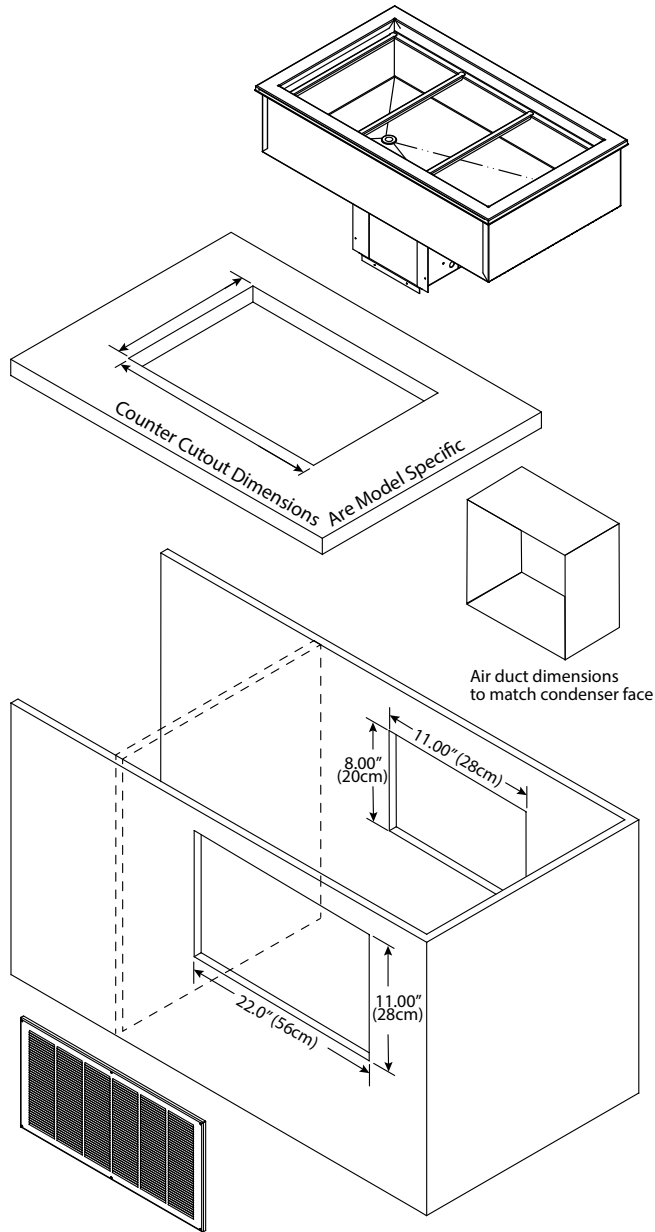

1. Install partitions between self-contained refrigerated drop-in units and other electrical appliances if they are located in the same cabinet. Partitions must fully extend front to back and top to bottom.
2. Install a GFCI receptacle a minimum of 14" (36cm) up from the cabinet bottom inside the partitions. Run the outlet to a switch. With limited access to the control, a switch will make it easy to turn the unit off for defrost.
3. The unit requires airflow to the compressor. One louver is provided with each unit.

NOTE: Any restriction to the proper air flow will void the compressor warranty.

- A 13" x 25" (33 cm x 64 cm) louver is provided by Delfield and must be installed in the counter in front of the condenser. The louver cutout dimension is 22" x 11" (56 cm x 28 cm).
- The rear must have an opening for removal of heated air. The opening must be at least 11" x 8", a total of 88 square inches (28cm x 20cm, a total of 566 square centimeters).

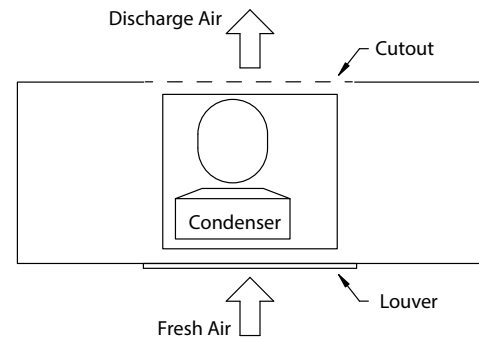

4. Place the condensing unit through the counter cutout.
5. A gasket is installed in the flange of each unit. The weight of the unit on the gasket forms a seal preventing liquids from seeping into the cut-out opening.
6. Plumb to a floor drain.
 - 8100-EF(N) models have a 1/2" ID PVC drain.
 - N8200 and N8200-ST models have a 1/2" OD stainless steel drain. Use clear flexible tubing.
 - N8200G models have a 3/4" drain located on end/center. Use a 3/4" female coupling.

7. The 1" diameter drain on N8100B, N8100-BR and N8100NB models is shipped loose and must be connected during installation.

- A. Provided 1" (25mm) drain, nut and washer must be field installed to an appropriate container or floor drain following local code requirements. Sinks come standard with 1-1/2" basket strainer assemblies.



- B. Remove/drill foam out of drain hole.



- C. Apply thin ring of plumbers putty around the drain.

- D. From the inside drop the drain into the drain hole.



- E. From the outside secure the drain with the washer and nut.

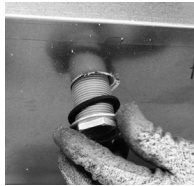

- F. Tighten the nut with channel locks, use a fork to hold the drain in place if necessary.

- G. Clean up excess plumbers putty.

8. Construct an air duct (not provided) connecting the condenser face to the louver. This will prevent recirculation of discharge air.

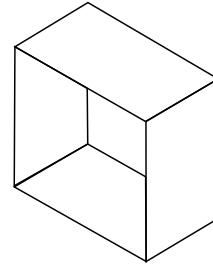

Air duct dimensions to match condenser face

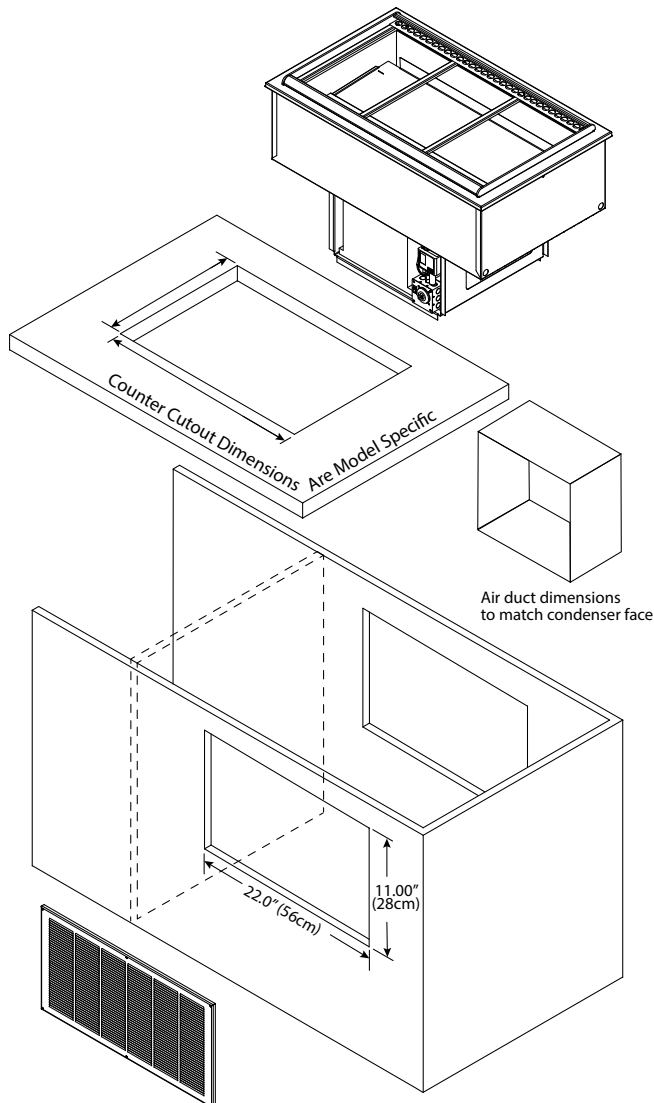
FORCED-AIR REFRIGERATED DROP-IN UNITS**N8100-FA**

1. Install partitions between self-contained refrigerated drop-in units and other electrical appliances if they are located in the same cabinet. Partitions must fully extend front to back and top to bottom.
2. Install a GFCI receptacle a minimum of 14" (36cm) up from the cabinet bottom inside the partitions. Run the outlet to a switch. With limited access to the control, a switch will make it easy to turn the unit off for defrost.
3. The unit requires airflow to the compressor. One louver is provided with each unit.

NOTE: Any restriction to the proper air flow will void the compressor warranty.

- A 13" x 25" (33 cm x 64 cm) louver is provided by Delfield and must be installed in the counter in front of the condenser. The louver cutout dimension is 22" x 11" (56 cm x 28 cm).
- The rear must have an opening for removal of heated air. The opening must be at least 174in² (1123cm²).

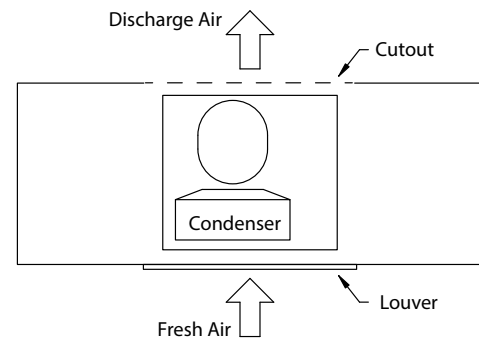

4. Place the condensing unit through the counter cutout.
5. A gasket is installed in the flange of each unit. The weight of the unit on the gasket forms a seal preventing liquids from seeping into the cut-out opening.

6. The 1" diameter drain on N8100-FA models is shipped loose and must be connected during installation. N8157-FA, N8169-FA and N8182-FA have two 1" drains.

A. Provided 1" (25mm) drain, nut and washer must be field installed to an appropriate container or floor drain following local code requirements. Sinks come standard with 1-1/2" basket strainer assemblies.



B. Remove/drill foam out of drain hole.



C. Apply thin ring of plumbers putty around the drain.

D. From the inside drop the drain into the drain hole.



E. From the outside secure the drain with the washer and nut.

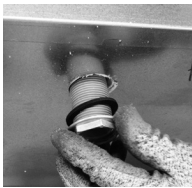

F. Tighten the nut with channel locks, use a fork to hold the drain in place if necessary.

G. Clean up excess plumbers putty.

7. Construct an air duct (not provided) connecting the condenser face to the louver. This will prevent recirculation of discharge air.

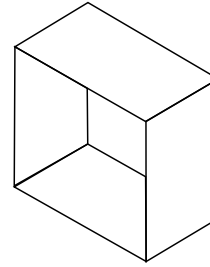

8. Inside the well, the fan assembly has standoff brackets with tabs. The tabs should be bent up.

9. Place the coil assembly cover slots over the bracket tabs. This will secure the cover is in the correct location and will not disrupt the air flow.

10. The upright air diffuser will only fit one way on the drain side.

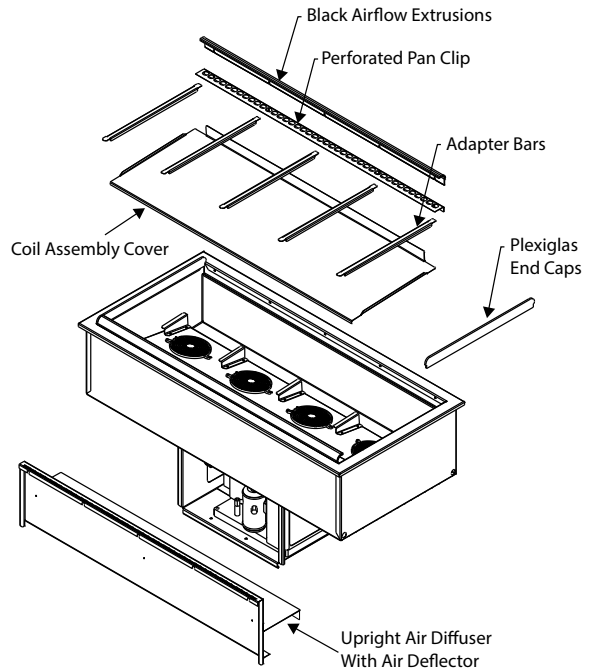

**SELF-CONTAINED COMBO HOT/COLD DROP-IN UNITS
N8600**

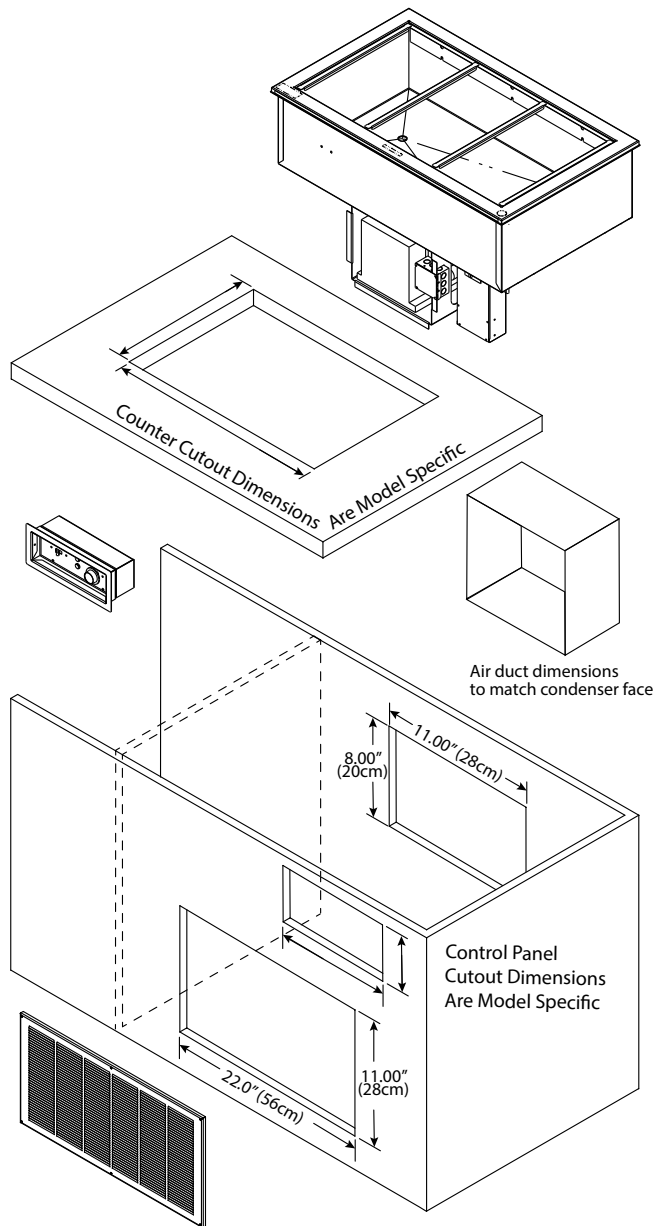

1. Install partitions between self-contained refrigerated drop-in units and other electrical appliances if they are located in the same cabinet. Partitions must fully extend front to back and top to bottom.
2. Install a GFCI receptacle a minimum of 14" (36cm) up from the cabinet bottom inside the partitions.
3. The unit requires airflow to the compressor. One louver is provided with each unit.

NOTE: Any restriction to the proper air flow will void the compressor warranty.

- A 13" x 25" (33 cm x 64 cm) louver is provided by Delfield and must be installed in the counter in front of the condenser. The louver cutout dimension is 22" x 11" (56 cm x 28 cm).
- The rear must have an opening for removal of heated air. The opening must be at least 11" x 8", a total of 88 square inches (28cm x 20cm, a total of 566 square centimeters).

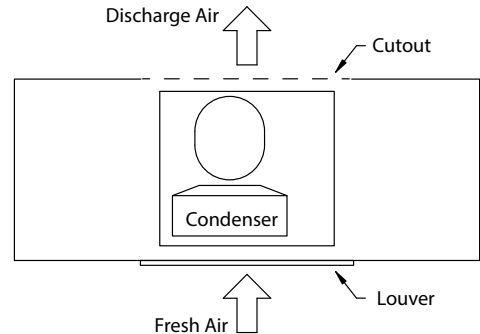

4. Orient the control panel with the indicator light for each control to the right of the control. N8600 series units have 40" (102cm) of conduit.
5. Place the control panel into the cutout from inside the cabinet. Place the collar into the cutout from outside the cabinet. Secure with two screws.
6. Place the condensing unit through the counter cutout.
7. A gasket is installed in the flange of each unit. The weight of the unit on the gasket forms a seal preventing liquids from seeping into the cut-out opening.
8. N8600 wells are sloped to a 1" (25mm) male NPT stainless steel drain. Plumb to a floor drain. Use a 1" female coupling.
9. Construct an air duct (not provided) connecting the condenser face to the louver. This will prevent recirculation of discharge air.

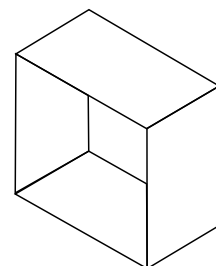

Air duct dimensions to match condenser face

HOT FOOD WELL DROP-IN UNITS
N8700-D, N8700-DESP, N8700N, N8700-R, N8800

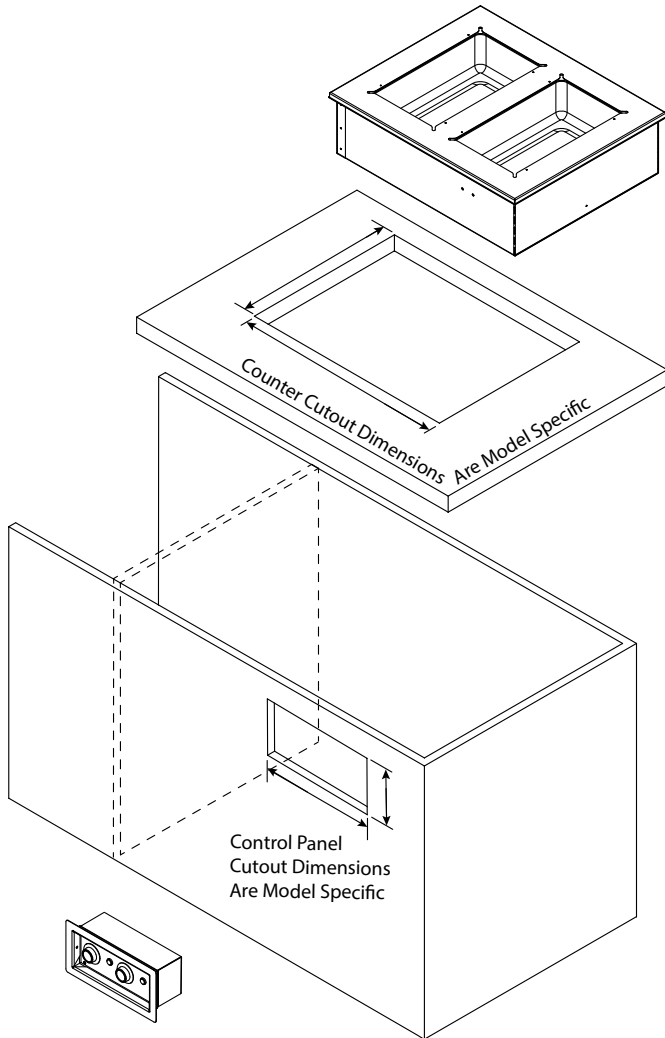

1. Orient the control panel with the indicator light for each control to the right of the control.
 - N8700 series units have 48" (122cm) of conduit.
 - N8800 Series units have 34" (86cm) of conduit.
2. N8700 control panel is designed to be installed on the side opposite the drains.
 - Installed on the same side as the drains, the control panel will either be upside down or the knobs will control the opposite wells.

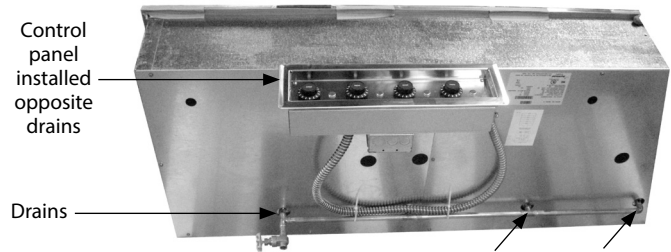

Infinite control shown, directions also apply to digital control

3. Place the control panel into the cutout from inside the cabinet. Place the collar into the cutout from outside the cabinet. Secure with two screws.
4. Place the hot food well drop-in unit through the counter cutout.
5. A gasket is installed in the flange of each unit. The weight of the unit on the gasket forms a seal preventing liquids from seeping into the cut-out opening.
6. Plumb to a floor drain.
 - All N8700 series are equipped with 1/2" (13mm) female NPT drains, one per well located right rear corner, manifold to 1/2" (13mm) gate valve.
 - N8800 wells are sloped to a 1" (25mm) male NPT stainless steel drain. Use a 1" female coupling.

Electrical Service

⚠ DANGER

Check all wiring connections, including factory terminals, before operation. Connections can become loose during shipment and installation.

⚠ Warning

This appliance must be grounded and all field wiring must conform to all applicable local and national codes. Refer to rating plate for proper voltage. It is the responsibility of the end user to provide the disconnect means to satisfy the authority having jurisdiction.

VOLTAGE

All electrical work, including wire routing and grounding, must conform to local, state and national electrical codes.

The following precautions must be observed:

- The equipment must be grounded.
- A separate fuse/circuit breaker must be provided for each unit.
- A qualified electrician must determine proper wire size dependent upon location, materials used and length of run (minimum circuit ampacity can be used to help select the wire size).
- The maximum allowable voltage variation is $\pm 10\%$ of the rated voltage at equipment start-up (when the electrical load is highest).
- Check all green ground screws, cables and wire connections to verify they are tight before start-up.

GROUND FAULT CIRCUIT INTERRUPTER

Ground Fault Circuit Interrupter (GFCI/GFI) protection is a system that shuts down the electric circuit (opens it) when it senses an unexpected loss of power, presumably to ground. Manitowoc does not recommend the use of GFCI/GFI circuit protection to energize our equipment. If code requires the use of a GFCI/GFI then you must follow the local code. The circuit must be dedicated, sized properly and there must be a panel GFCI/GFI breaker. We do not recommend the use of GFCI/GFI outlets to energize our equipment as they are known for more intermittent nuisance trips than panel breakers.

ELECTRICAL SPECIFICATIONS CHART

Units with plugs are supplied with approximately 6ft (183cm) cords.

Model	Amps	Watts	V, Hz, Ph	Plug
8100-EF Series				
8118-EF	7.5	-	115, 60, 1	NEMA 5-15P
8132-EF				
8145-EF				
8159-EF				
8172-EF				
8186-EF	8.0			
8100-EF-E Export Series				
8118-EF-E	2.5	600	230-240, 50, 1	Varies Per Destination
8132-EF-E				
8145-EF-E				
8159-EF-E				
8172-EF-E				
8186-EF-E				
8100-EFN Series				
8148-EFN	7.5	-	115, 60, 1	NEMA 5-15P
8169-EFN				
8191-EFN				
8100-EFN-E Export Series				
8148-EFN-E	2.5	600	230-240, 50, 1	Varies Per Destination
8169-EFN-E				
8191-EFN-E				
N8000 Series - NA				
N8000N Series - NA				
N8000-R Series - NA				
N8100B Series				
N8118B	3.7	-	115, 60, 1	NEMA 5-15P
N8130B				
N8143B				
N8156B				
N8169B	5.6			
N8181B		7.3		
N8100B-E Export Series - R404A				
N8118B-E	1.5	360	230-240, 50, 1	Varies Per Destination
N8130B-E				
N8143B-E				
N8100B-E Export Series - R134A				
N8156B-E	2.5	600	230-240, 50, 1	Varies Per Destination
N8169B-E				
N8100BR Series				
N8144-BR	4.0	-	115, 60, 1	NEMA 5-15P
N8159-BR	7.0			
N8176-BR	7.3			
N8194-BR	8.0			
N8100-FA Series				
N8131-FA	7.8	-	115, 60, 1	NEMA 5-15P
N8144-FA	9.2			
N8157-FA				
N8169-FA	14.8			
N8182-FA				
N8100NB Series				
N8146NB	3.7	-	115, 60, 1	NEMA 5-15P
N8168NB	5.6			

Model	Amps	Watts	V, Hz, Ph	Plug
N8100NB-E Export Series				
N8146NB-E	1.5	360	230-240, 50, 1	Varies Per Destination
N8168NB-E				
N8200 Series				
N8231	7.5	-	115, 60, 1	NEMA 5-15P
N8245				
N8259				
N8273				
N8287				
N8200-E Export Series				
N8231-E	1.5	360	230-240, 50, 1	Varies Per Destination
N8245-E		360		
N8259-E	2.5	600	230-240, 50, 1	Varies Per Destination
N8273-E		600		
N8287-E		650		
N8200G Series				
N8231G	7.5	-	115, 60, 1	NEMA 5-15P
N8245G				
N8259G				
N8273G				
N8200G-E Export Series				
N8231G-E	1.5	360	230-240, 50, 1	Varies Per Destination
N8245G-E				
N8259G-E	2.8	672		
N8200-ST Series				
N8230-ST	7.5	-	115, 60, 1	NEMA 5-15P
N8240-ST				
N8256-ST				
N8258-ST				
N8275-ST				
N8600 Series				
N8630	24.0	-	120, 60, 1	Hard Wire
N8643	21.0	-	120/240, 60, 1	
N8656				
N8669	43.0	-	120/240, 60, 1	
N8681				
N8700D Series				
N8717-D	8.3	-	120, 60, 1	Hard Wire
N8731-D	16.6			
N8745-D	15.0/16.0	-	208-230, 60, 1	
N8759-D	20.0/22.0			
N8773-D	24.0/27.0			
N8787-D	29.0/32.0			
N8700D-E Export Series				
N8717-D-E	6.0	1450	240, 50, 1	Hard Wire
N8731-D-E	12.1	2900		
N8745-D-E	18.1	4350		
N8759-D-E	24.2	5800		
N8773-D-E	30.2	7250		
N8787-D-E	36.3	8700		
N8700DESP Series				
N8717-DESP	2.4/2.7	-	208-230, 60, 1	Hard Wire
N8731-DESP	4.8/5.4			
N8745-DESP	7.2/8.1			
N8759-DESP	9.6/10.8			
N8773-DESP	12.0/13.5			
N8787-DESP	14.4/16.2			

Model	Amps	Watts	V, Hz, Ph	Plug
N8700-D-ESP-E Export Series				
N8717-D-ESP-E	2.1	500	240, 50, 1	Hard Wire
N8731-D-ESP-E	4.2	1000		
N8745-D-ESP-E	6.3	1500		
N8759-D-ESP-E	8.4	2000		
N8773-D-ESP-E	10.5	2500		
N8787-D-ESP-E	12.6	3000		
N8700N Series				
N8746ND	17.0	-	120, 60, 1	Hard Wire
N8768N	15.0/16.0	-	208-230, 60, 1	
N8768ND				
N8700-R Series				
N8744-R	16.6	-	120, 60, 1	Hard Wire
N8759-R	15.0/16.0	-	208-230, 60, 1	
N8776-R	20.0/22.0			
N8794-R	24.0/27.0			
N8800 Series				
N8831	17.0	-	120, 60, 1	Hard Wire
N8845	15.0/16.0	-	208-230, 60, 1	
N8859	20.0/22.0			
N8873	24.0/27.0			
N8887	29.0/32.0			
N8800-E Export Series				
N8831-E	12.1	2900	240, 50, 1	Hard Wire
N8845-E	18.1	4350		
N8859-E	24.2	5800		
N8873-E	30.2	7250		
N8887-E	36.3	8700		

Refrigeration

Temperature Class for all Export units is N.

Model	H.P.	BTU Load	Evap BTU/TD/TEMP	Sys Cap	Refrig. Charge
8100-EF Series					R404A
8118-EF	1/4	204	19/50°/-15°	928	16.0oz
8132-EF	1/4	379	26/42°/-7°	1112	
8145-EF	1/4	569	35/36°/-1°	1259	
8159-EF	1/4	758	43/32°/3°	1373	
8172-EF	1/4	948	51/29°/6°	1469	
8186-EF	1/3	1138	59/26°/9°	1529	24.0oz
8100-EF-E Export Series					R404A
8118-EF-E	1/4	204	19/50°/-15°	928	454g
8132-EF-E	1/4	379	26/42°/-7°	1112	
8145-EF-E	1/4	569	35/36°/-1°	1259	
8159-EF-E	1/4	758	43/32°/3°	1373	
8172-EF-E	1/4	948	51/29°/6°	1469	
8186-EF-E	1/3	1138	59/26°/9°	1529	
8100-EFN Series					R404A
8148-EFN	1/4	379	26/42°/-7°	1112	16.0oz
8169-EFN	1/4	569	35/36°/-1°	1259	
8191-EFN	1/4	758	43/32°/13°	1373	
8100-EFN-E Export Series					R404A
8148-EFN-E	1/4	379	26/42°/-7°	1112	454g
8169-EFN-E	1/4	569	35/36°/-1°	1259	
8191-EFN-E	1/4	758	43/32°/13°	1373	
N8000 Series NA					
N8000N Series - NA					
N8000-R Series - NA					
N8100B Series					R404A
N8118B	1/5	204	19/38°/-3°	1010	6.0oz
N8130B	1/5	379	26/31°/4°	1298	7.5oz
N8143B	1/5	569	35/26°/9°	1298	9.2oz
N8156B	1/4	758	43/32°/3°	1961	6.5oz
N8169B	1/4	948	51/29°/6°	2088	6.5oz
N8181B	1/3	1138	59/32°/3°	2088	7.5oz
N8100B-E Export Series					R404A
N8118B-E	1/5	204	19/38°/-3°	708	454g
N8130B-E	1/5	379	26/31°/4°	812	
N8143B-E	1/5	569	35/26°/9°	889	
N8100B-E Export Series					R134A
N8156B-E	1/4	758	43/32°/3°	1373	227g
N8169B-E	1/4	948	51/29°/6°	1469	
N8100BR Series					R404A
N8144-BR	1/5	379	26/31°/4°	812	9.4oz
N8159-BR	1/4	569	35/26°/9°	889	6.5oz
N8176-BR	1/3	758	43/32°/3°	1373	7.5oz
N8194-BR	1/3	948	51/29°/6°	1469	7.9oz
N8100-FA Series					R404A
N8131-FA	1/4	1339	140/15°/20°	2154	16.0oz
N8144-FA	1/2	2035	140/22°/13°	3142	32.0oz
N8157-FA	1/2	2731	280/14°/21°	3806	32.0oz
N8169-FA	3/4	3374	280/20°/15°	5545	48.0oz
N8182-FA	3/4	4070	280/20°/15°	5545	48.0oz
N8100NB Series					R134A
N8146NB	1/5	454	17/40°/-5°	680	8.5oz
N8168NB	1/5	676	26/31°/4°	804	6.5oz
N8100NB-E Export Series					R404A
N8146NB-E	1/5	454	17/40°/-5°	680	454g
N8168NB-E	1/5	676	26/31°/4°	804	

Model	H.P.	BTU Load	Evap BTU/TD/TEMP	Sys Cap	Refrig. Charge
N8200 Series					R404A
N8231	1/4	379	26/42°/-7°	1112	16.0oz
N8245	1/4	569	35/36°/-1°	1259	
N8259	1/4	758	43/32°/3°	1373	
N8273	1/4	948	51/29°/6°	1469	
N8287	1/3	1138	59/30°/5°	1787	24.0oz
N8200-E Export Series					R404A
N8231-E	1/5	379	26/42°/-7°	1112	454g
N8245-E	1/5	569	35/36°/-1°	1259	
N8259-E	1/4	758	43/32°/3°	1373	
N8273-E	1/4	948	51/29°/6°	1469	
N8287-E	1/3	1138	59/30°/5°	1787	
N8200G Series					R404A
N8231G	1/4	379	26/42°/-7°	1112	16.0oz
N8245G	1/4	569	35/36°/-1°	1259	16.0oz
N8259G	1/3	758	43/37°/-2°	1572	24.0oz
N8273G	1/2	948	51/43°/-8°	2183	40.0oz
N8200G-E Export Series					R404A
N8231G-E	1/5	379	26/42°/-7°	1112	454g
N8245G-E	1/5	569	35/36°/-1°	1259	
N8259G-E	1/3	758	43/37°/-2°	1572	
N8200-ST Series					R404A
N8230-ST	1/4	332	26/44°/-9°	1128	16.0oz
N8240-ST	1/4	559	35/37°/-2°	1295	
N8256-ST	1/4	624	39/35°/0°	1359	
N8258-ST	1/4	870	44/33°/2°	1422	
N8275-ST	1/4	1140	53/29°/6°	1520	
N8600 Series					
N8630	1/4	379	26/42°/-7°	1112	16.0oz
N8643	1/4	569	35/36°/-1°	1259	
N8656	1/4	758	43/32°/3°	1373	
N8669	1/4	948	51/29°/6°	1469	
N8681	1/3	1138	59/30°/5°	1787	
N8700D Series - NA					
N8700D-E Export Series - NA					
N8700DESP Series - NA					
N8700-D-ESP-E Export Series - NA					
N8700N Series - NA					
N8700-R Series - NA					
N8800 Series - NA					
N8800-E Export Series					

Optional Auto Fill Installation

- Option is a loose parts kit. Installation requires a plumber.
- The purpose of the auto fill assembly is to maintain the level of water lost throughout operation as it steams away. If using it to fill an empty unit it will fill slowly and you may want to start by manually filling the unit.

APPLICABLE TO N8600 & N8800 MODELS

1. Locate mounting holes on outside operator drop-in body and mount float and bracket using thumb screws.
2. Install drain plumbing as shown.
3. Connect clear plastic tubing to 1/2" copper stub and connect to the float. Use hose clamps to secure.
4. Connect fill line to 1/4" compression fitting.
5. Loosen thumb screws to achieve desired water level.

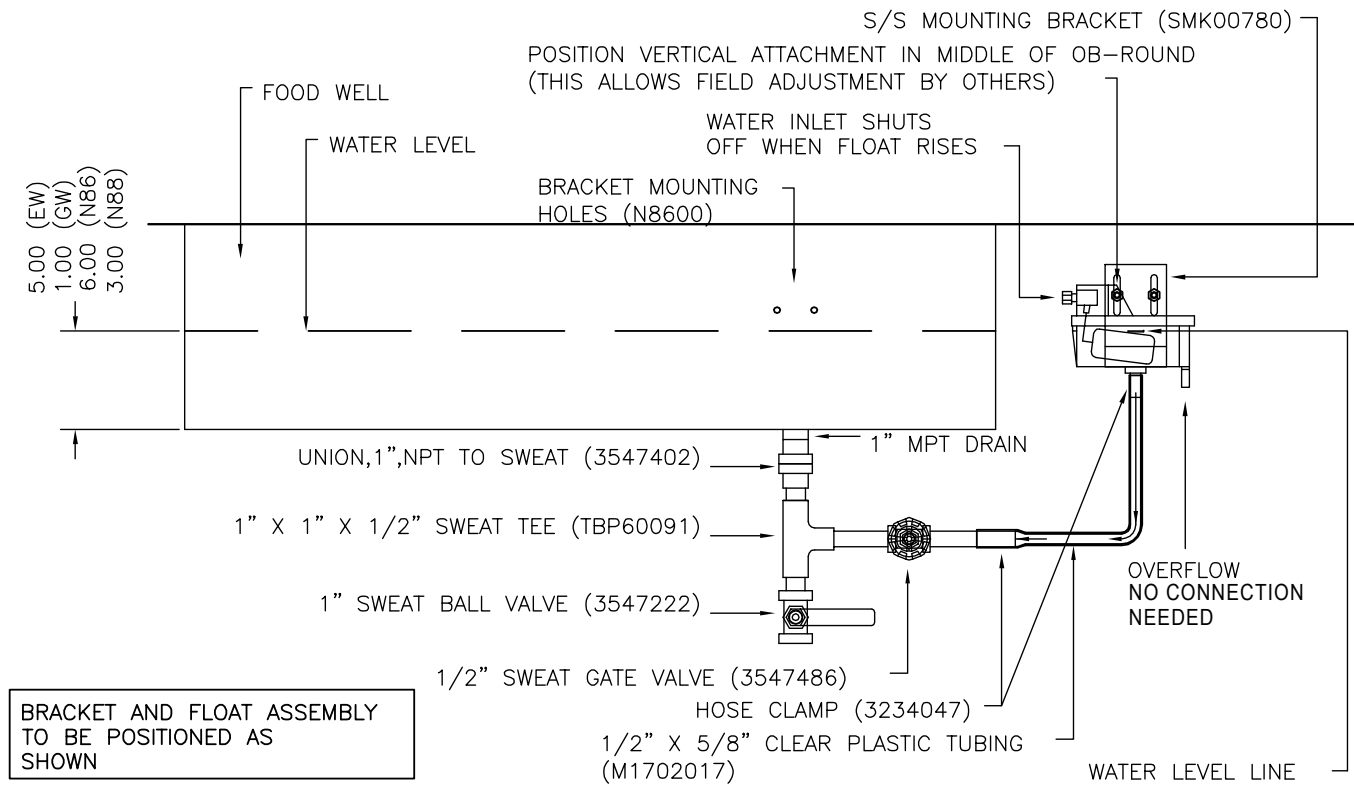

Optional Auto Fill Installation

- Option is a loose parts kit. Installation requires a plumber.
- The purpose of the auto fill assembly is to maintain the level of water lost throughout operation as it steams away. If using it to fill an empty unit it will fill slowly and you may want to start by manually filling the unit.

APPLICABLE TO N8700 MODELS

1. Locate mounting holes on outside operator drop-in body and mount float and bracket using thumb screws.
2. Install drain plumbing as shown.
3. Connect clear plastic tubing to 1/2" copper stub and connect to the float. Use hose clamps to secure.
4. Connect fill line to 1/4" compression fitting.
5. Loosen thumb screws to achieve desired water level.

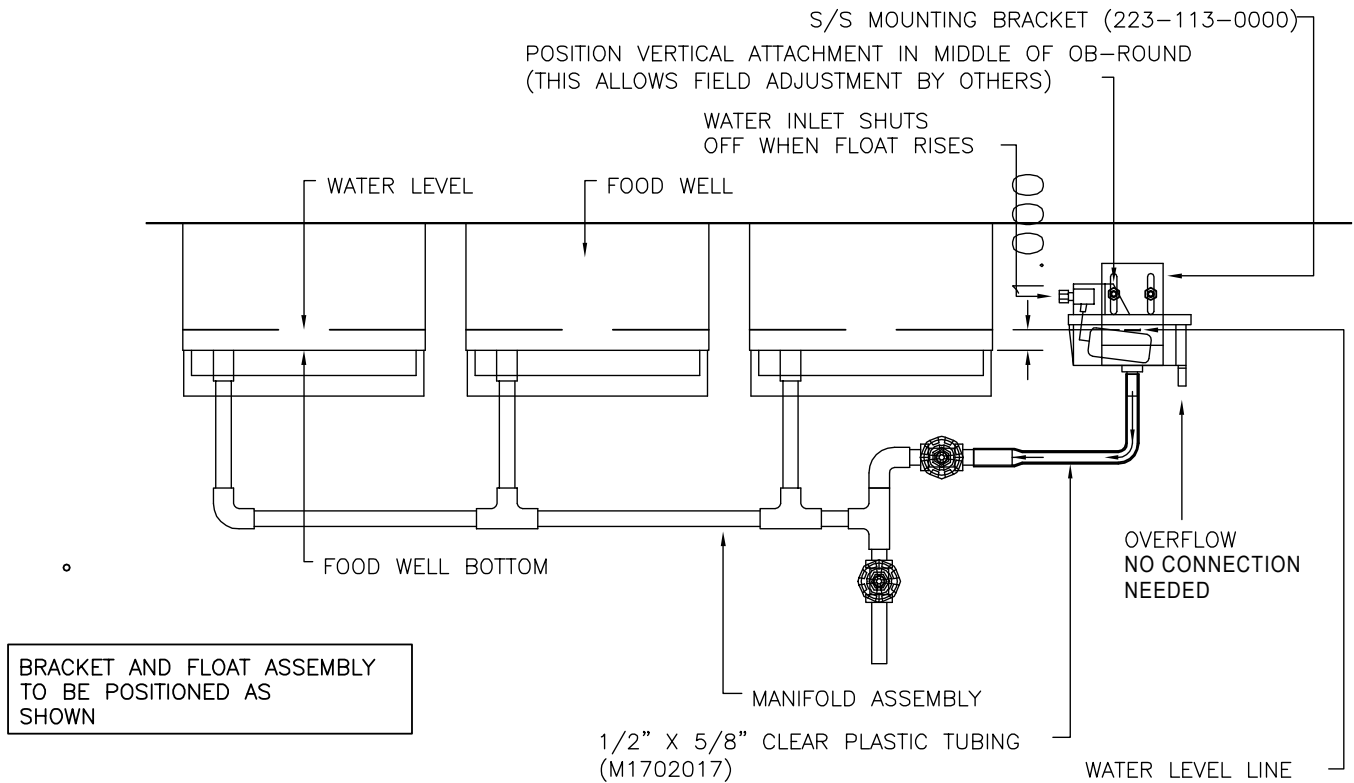

THIS PAGE INTENTIONALLY LEFT BLANK

Section 3 Operation

⚠ DANGER

The on-site supervisor is responsible for ensuring that operators are made aware of the inherent dangers of operating this equipment.

⚠ DANGER

Do not operate any appliance with a damaged cord or plug. All repairs must be performed by a qualified service company.

⚠ DANGER

Never stand on the unit! They are not designed to hold the weight of an adult, and may collapse or tip if misused in this manner.

⚠ Warning

Do not contact moving parts.

⚠ Warning

All covers and access panels must be in place and properly secured, before operating this equipment.

⚠ Warning

Damp or wet hands may stick to cold surfaces.

⚠ Warning

Never use sharp objects or tools to remove ice or frost. Do not use mechanical devices or other means to accelerate the defrosting process.

⚠ Warning

Do not block the supply and return air grills or the air space around the air grills. Keep plastic wrappings, paper, labels, etc. from being airborne and lodging in the grills. Failure to keep the air grills clear will result in unsatisfactory operation of the system.

⚠ Caution

Units with pans should be operated with pans in place. Operating the unit without all pans in place will lower efficiency and may damage the unit.

Product Quality in Cold Pans

⚠ Warning

The operator of this equipment is solely responsible for ensuring safe holding temperature levels for all food items. Failure to do so could result in unsafe food products for customers.

These units are not designed to cool warm food products. Items should be placed in the unit pre-cooled at least to the desired holding temperature, if not slightly colder. In some applications, a gradual warming of product may occur, particularly at the exposed top of the product. Stirring or rotation of the product is necessary to maintain overall temperature.

Warming of food product can occur very quickly outside of the unit. When loading or rotating product, avoid leaving food items in a non-refrigerated location for any length of time to prevent warming or spoilage. To ensure product quality product must be rotated every four hours.

8100-EF(N) Series Operation

Note

The cold pan is not intended to be used with ice.

There is a switch on the compressor housing front to turn the 8100-EF units on and off. The unit must be turned off when not in use or overnight for defrosting and cleaning.

8100-EF Series LiquiTec® Eutetic fluid cold pans are adjusted at the factory to provide proper operation without any further adjustments.

The temperature control is located on the condensing housing.

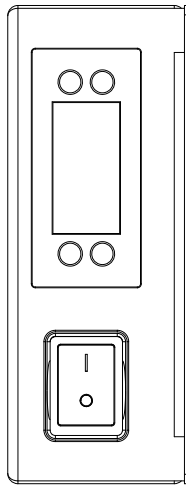

Power Switch & Temperature Control

1. At initial start-up or anytime power is disconnected, then reconnected to the unit, the control will go into normal cooling mode.
2. The temperature control will cycle the compressor and condenser fan motor to maintain proper temperature.

Notice

Temperature displayed is for refrigeration set point purposes only. Display does not reflect air or product temps in unit.

TEMPERATURE CONTROL & DISPLAY

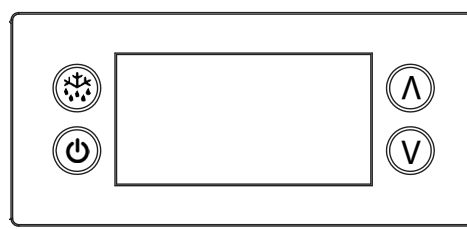

Operation / Indication			
Status	Displayed		Comments
Normal (°C)	Temp. [°C]		Unit depends on setting (parameters in control)
Normal (°F)	Temp. [°F]		
Show set-point	Temp.		
Sensor 1 defect	E01	X	Air sensor
Sensor 2 defect	E02	X	Coil sensor
Sensor 3 defect	E03	X	Open
Sensor 4 defect	E04	X	Open
High temperature alarm	Hi	X	Automatically switching at 2 sec rate
Low temperature alarm	Lo	X	
Line voltage too high, above 140 volts	uHi	X	
Line voltage too low, below 96 volts	uLi	X	
Control calls for cooling for more than 24 hours straight	LEA	X	Time includes defrost. Error will go away if the control cycles off the compressor or if the power is shut off. If error is on a cold pan it could be related to a high ambient temperature or not shutting the rail off nightly.

All alarms sound for approximately 10 seconds and then are silent for 50 seconds. It will do that for 15 cycles and then remain silent. The alarm code will still be present on the display until the fault clears.

Press upper or lower right button.

- Display show actual set-point (blinking).
 - If buttons untouched for 3 seconds returns to normal.
- Increase set-point by pressing upper button. Max value depends on parameters in control.
- Decrease set-point by pressing lower button. Min value depends on parameters in control.
 - If buttons untouched for 3 seconds returns to normal and stores new set-point.

Press lower left button for 5 seconds.

- Unit goes into stand-by mode.
 - The display will read Off, then a period.
- Press the lower left button again for 5 seconds.
 - The display will read On.
 - The unit will then start up in normal cooling mode.

Temperature Alarm

The alarm will sound and flash HI or LO 90 minutes after the unit has reached its alarm temperature point or after any power interruption if the temperature is above or below the alarm set points.

CHANGING DISPLAY FROM FAHRENHEIT TO CELSIUS ON ERC112 CONTROL

1. Simultaneously hold the up and down arrows for 5 seconds to access menu for password protected parameters.



2. Screen should temporarily flash **PAS** and then move to a numeric screen.



3. Scroll to **187** using the up/down arrows and push the stand-by button (lower left button) to enter.



4. Scroll to **dis** using the up/down arrows and push the stand-by button (lower left button) to enter into the display menu.



5. Scroll to **CFu** using the up/down arrows and push the stand-by button (lower left button) to enter the display unit menu.



6. **-F** should be displayed indicating Fahrenheit. Use the down arrow to change it to **-C** for Celsius and hit the stand-by button (lower left button) to enter the change.



7. Push the defrost button (upper left button) to move out of the display unit menu.



8. Push the defrost button (upper left button) to move out of the display menu and back to the normal display.

NOTE: For steps 7 and 8, display will return back to normal display after 30 seconds of inactivity.



N8100B, N8100-BR & N8100NB Operation

The temperature control is used to turn the unit on and off as well as control the temperature of the cold pan. The control is located in the machine compartment. To turn the cold pan off, turn the knob to the off position. The unit must be turned off when not in use or overnight for defrosting and cleaning.

If the cold pan is to be used with ice, it is recommended that the optional perforated bottoms be used. These will allow ice to melt properly.

These mechanically cooled cold pans are adjusted at the factory to provide proper operation. However, if it is necessary to adjust the temperature, turn the knob clockwise as indicated on the control. Settings are from 1 thru 7 (7 being the coldest).

- Adjustments should be made gradually.
- Several small adjustments will be more effective than one large adjustment.
- It may take an hour or longer to realize the temperature change depending on the application and location of the unit.

N8100-FA Operation

There is a switch on the compressor housing front to turn the N8100-FA units on and off. The unit must be turned off when not in use or overnight for defrosting and cleaning.

NOTE: Food in the N8100-FA pans should not be loaded in such a way as to interfere with the air curtain flowing over the cold pans.

Defrost Timer

The recommended defrost timer setting is every 2 hours for 15 minutes.

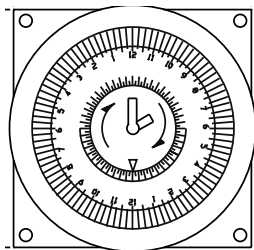

Pressure Control

The temperature is controlled by an adjustable pressure control located in the machine compartment and adjustable control has the word COLDER near the knob, with an arrow to indicate the adjustment direction. This control is field adjustable and does not require a service agent. If you have any questions, call an authorized service agent.

In attempting to adjust the pressure control, you can do damage to the unit by accidentally adjusting the differential.

NOTE: Delfield is not responsible for charges incurred while adjusting the pressure control.

Factory settings are:

- 30 psi (207 kPa) differential
- 80 psi (552 kPa) cut-in
- 50 psi (345 kPa) cut-out

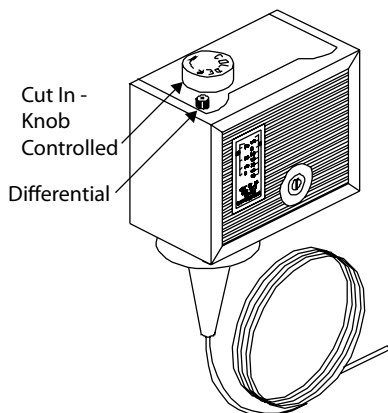

N8200 & N8200-ST Operation

N8200 and N8200-ST series frost tops are designed to maintain an even layer of frost to pleasantly display product. Once turned on, the compressor will run continuously. There is no temperature control. The ON/OFF switch is the only means available to cycle the unit.

Since it takes time for the frost to accumulate initially, the unit should be turned on approximately one hour before it is required. Product should not be placed on the frost top prior to turning the unit on, because it may freeze to the surface of the unit.

The unit must be turned off when not in use or overnight for defrosting and cleaning.

Operation N8200G

N8200G Series granite cold slabs are designed to maintain a low temperature surface for quick turn products such as ice cream. Frost patterns will vary depending on room conditions such as temperature, humidity and airflow. The work zone of the granite surface is considered to be inside a 2.0" (5.1cm) perimeter. Temperatures in the perimeter zone may be higher and again the frost patterns in this area will vary based on room conditions.

Unit is controlled by an on/off switch. Once turned on, the unit will run continuously. There is no temperature control in this unit. Turn the unit on approximately two hours prior to use to allow for ample cool down time. At 75°F ambient temperature the unit will reach operating temperature of 0°F to 20°F in 2 hours.

The unit must be turned off when not in use or overnight for defrosting and cleaning.

8600 Hot/Cold Series Operation

Hot Operation

DANGER

When operated at the highest temperature setting, the top of the unit will become very hot. Staff and customers using the equipment should be informed about this.

Caution

Never use anything other than plain water in the wells or tank. Failure to observe this warning may result in personal injury or damage to the unit.

Caution

Using ice in a hot food well can cause condensation and damage to the well over time.

N8600 Series hot and cold combination pans must be operated with water in the well for proper hot operation. Fill well with a minimum of 4.0" (10.2cm) of water. Place function switch in HOT position to begin heating. Turn thermostat dial to the desired temperature.

To turn unit off, simply move the function switch to OFF position. Drain water and allow unit to cool before cleaning or switching to cold operation.

Switching From Hot To Cold Operation

1. Place the function switch in the OFF position and drain out hot water.
2. Allow the unit to cool until it can be safely cleaned.
3. When clean up procedures are complete, unit will be ready for cold operation. This takes about one hour.

Caution

To assure maximum compressor life, do not switch from "hot" to "cold" operation without allowing a cool down period. Never switch from hot to cold operation while hot water remains in the pans. Failure to observe this warning will greatly reduce compressor life and eventually cause premature compressor failure.

Cold Operation

Simply place the function switch to the COLD position. The compressor controller has been factory set and no temperature adjustment should be necessary.

If the cold pan is to be used with ice, it is recommended that the optional perforated bottoms be used. These will allow ice to melt properly.

Switching From Cold To Hot Operation

No special procedure is required to switch from the cold to hot operation. Be certain to fill with a minimum of 4.0" of water.

Note

The unit is designed so that the compressor and the heating elements cannot operate at the same time. Continued operation of the compressor in the hot position is not normal. Call for service if this happens.

The unit must be turned off when not in use or overnight for defrosting and cleaning.

N8600 Immersion Heater High Limit

As a safety feature, the N8600 food well immersion heater includes a high limit safety switch. If the heater gets too hot the safety switch will trip and turn the heater off. A pilot light on the control panel will illuminate when the safety switch is tripped. To reset the safety switch, first turn OFF the thermostat or Power switch and then determine if low water is the cause. If low water is not the cause, contact service for resolution. If low water is the cause, carefully remove food pans and refill the water. This will allow the immersion heater to cool and the safety switch will automatically reset. The unit must be turned OFF as directed or safety switch will not reset even if water is refilled to proper level. Replace food pans and turn thermostat or Power switch back on.

N8700-D, N8700N, N8700-R & N8800 Series Operation

These units are designed to hold warm food product between 140°F to 160°F (60°C to 71°C).

N8700-D, N8700N and N8700-R series individually heated hot food units may be operated wet (with water in the wells) or dry. Wet operation is recommended for better performance.

N8800 Series single tank hot food units are designed to be operated wet (with water in the tank) only.

Note

Proper water level is approximately 2.0" (5.1cm). It must be maintained to prevent damage to the tank on the N8800 Series units.

After the unit is hard wired to the electrical system, select desired temperature by rotating temperature control. A knob and indicator light are provided for each individual heated food well.

First Time Use

Before the unit is used the first time for serving, turn the temperature knob to HI and heat the well for 20 to 30 minutes.

Any residue or dust that adhered to the heater element(s) will be burned off during this initial preheat period.

When serving thick sauces always use the hot food well in wet operation. This provides more uniform temperature for the sauce.

Note

Never place food directly in well. Always use pans.

For most efficient operation, keep covered inserts in each well during preheating or when empty.

Always place covers on pans when not serving to prevent food from drying out.

Wet Operation

DANGER

When operated at the highest temperature setting, the top of the unit will become very hot. Staff and customers using the equipment should be informed about this.

DANGER

Steam can cause serious burns. Always use some type of protective covering on your hands and arms when removing lids from the unit. Lift the lid in a way that will direct escaping steam away from your face and body.

Caution

Never use anything other than plain water in the wells or tank. Failure to observe this warning may result in personal injury or damage to the unit.

Caution

Using ice in a hot food well can cause condensation and damage to the well over time.

Fill the food well with a minimum of 2.0" (5.1cm) of water and cover with lid or empty pan. To preheat water, set temperature control at HI. With pans in place, wells will boil water. Food temperature will vary depending on type and amount of product. To minimize steam and water usage, set control at lowest setting that will maintain proper food temperature. To reduce preheating time, use hot water to fill the well.

Dry Operation N8700 Series only

DANGER

When operated dry, the well bottoms become very hot. Do not allow unprotected skin to contact any well surface.

Wet operation is usually much more efficient and is preferred. However, these units may be operated without water with no damage to the unit.

When operated dry, the bottom of the well will discolor. To clean, use a stainless steel cleaner or mild abrasive.

N8700-DESP Operation

These units are designed to hold warm food product between 140°F to 160°F (60°C to 71°C).

N8700-DESP series individually heated hot food units may be operated wet (with water in the wells) or dry. However, dry operation using 6.0" deep pans produces optimum performance.

A power switch and digital control are provided for each individual heated food well. After the unit is hard wired to the electrical system, turn the power switch ON to energize the control; the digital display will read OFF. Press Set and then use the arrows to select the desired temperature setting (1-10). The new temperature setting is entered 3 seconds after the last button is pressed. When the power switch is used to turn the well OFF and back ON the temperature setting will remain.

Note

Never place food directly in well. Always use pans.

For most efficient operation, keep covered inserts in each well during preheating or when empty.

Always place covers on pans when not serving to prevent food from drying out.

Dry Operation

⚠ DANGER

When operated dry, the well bottoms become very hot. Do not allow unprotected skin to contact any well surface.

Dry operation is more efficient and is preferred.

When operated dry, the bottom of the well will discolor. To clean, use a stainless steel cleaner or mild abrasive.

Wet Operation

⚠ DANGER

When operated at the highest temperature setting, the top of the unit will become very hot. Staff and customers using the equipment should be informed about this.

⚠ DANGER

Steam can cause serious burns. Always use some type of protective covering on your hands and arms when removing lids from the unit. Lift the lid in a way that will direct escaping steam away from your face and body.

⚠ Caution

Never use anything other than plain water in the wells or tank. Failure to observe this warning may result in personal injury or damage to the unit.

⚠ Caution

Using ice in a hot food well can cause condensation and damage to the well over time.

Fill the food well with a minimum of 2" (5cm) of water and cover with lid or empty pan. To preheat water, set temperature control at 3. With pans in place, wells will boil water. Food temperature will vary depending on type and amount of product. To minimize steam and water usage, set control at lowest setting that will maintain proper food temperature. To reduce preheating time, use hot water to fill the well. Preheating time with room temperature water is one hour.

N8700-DESP Temperature Control Operation

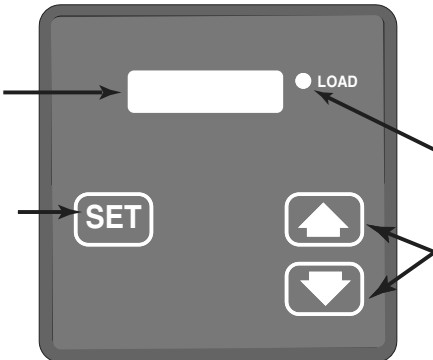

- LED DISPLAY: Indicates the temperature setting 0-10. At the first startup the display will read OFF.
- SET: When SET is depressed, the temperature setting is displayed and can be adjusted with the arrows.
- LOAD LIGHT: Lit when well is heating.
- ARROWS: After pressing SET, press the Up-Arrow to increase the temperature setting, press the Down-Arrow to decrease the temperature setting. The new temperature setting is entered 3 seconds after the last arrow is pressed.

Food Well Bottom Surface Temperatures

NOTE: Temperatures correspond to the food well bottom surface; they do not represent product temperatures.

Control	°F	°C
1	161	72
2	182	83
3	203	95
4	224	107
5	245	118

Control	°F	°C
6	266	130
7	287	142
8	308	153
9	329	165
10	350	177

Section 4 Maintenance

⚠ DANGER

It is the responsibility of the equipment owner to perform a personal protective equipment hazard assessment to ensure adequate protection during maintenance procedures.

⚠ DANGER

Failure to disconnect the power at the main power supply disconnect could result in serious injury or death. The power switch DOES NOT disconnect all incoming power.

⚠ DANGER

Disconnect electric power at the main power disconnect for all equipment being serviced. Observe correct polarity of incoming line voltage. Incorrect polarity can lead to erratic operation.

⚠ Warning

Never use sharp objects or tools to remove ice or frost. Do not use mechanical devices or other means to accelerate the defrosting process.

Cleaning and Sanitizing Procedures

⚠ Caution

Maintenance and servicing work other than cleaning as described in this manual must be done by an authorized service personnel.

GENERAL

⚠ Warning

When using cleaning fluids or chemicals, rubber gloves and eye protection (and/or face shield) must be worn.

You are responsible for maintaining the equipment in accordance with the instructions in this manual. Maintenance procedures are not covered by the warranty.

Maintenance	Daily	Weekly	Monthly	After Prolonged Shutdown	At Start-Up
Exterior	X			X	X
Gasket	X			X	X
N8100-FA Series Drain		X		X	X
Condenser Coil			X	X	X

EXTERIOR CLEANING

Warning

When cleaning the unit, care should be taken to avoid the front power switch and the rear power cord. Keep water and/or cleaning solutions away from these parts.

Warning

Never use a high-pressure water jet for cleaning or hose down or flood the units with water. Do not use power cleaning equipment, steel wool, scrapers or wire brushes on stainless steel or painted surfaces.

Caution

Never use an acid based cleaning solution, including a delimer! Acid will deteriorate the finish and damage the heating element. Food products can also be acidic, keep equipment clean of ALL food products.

Clean the area around the unit as often as necessary to maintain cleanliness and efficient operation.

Gaskets require daily cleaning to prevent mold and mildew build up and also to retain the elasticity of the gasket. Gasket cleaning can be done with the use of warm soapy water (no citrus based cleaners). Avoid full strength cleaning products on gaskets as this can cause them to become brittle and crack. Never use sharp tools or knives to scrape or clean the gasket.

Wipe surfaces with a damp cloth rinsed in water to remove dust and dirt from the unit. Always rub with the "grain" of the stainless steel to avoid marring the finish. If a greasy residue persists, use a damp cloth rinsed in a mild dish soap and water solution. Wipe dry with a clean, soft cloth.

Never use steel wool or abrasive pads for cleaning. Never use chlorinated, citrus based or abrasive cleaners.

Stainless steel has a clear coating that is stain resistant and easy to clean. Products containing abrasives will damage the coating and scratch the panels. Daily cleaning may be followed by an application of stainless steel cleaner which will eliminate water spotting and fingerprints. Early signs of stainless steel breakdown are small pits and cracks. If this has begun, clean thoroughly and start to apply stainless steel cleaners in attempt to restore the steel.

N8600 Immersion Heater

Follow the same as instructions as the rest of the food well: Wipe surfaces with a damp cloth rinsed in water to remove dust and dirt from the unit. If a greasy residue persists, use a damp cloth rinsed in a mild dish soap and water solution. Wipe dry with a clean, soft cloth. Never use steel wool or abrasive pads for cleaning. Never use chlorinated, citrus based or abrasive cleaners.

Defrosting

Refrigerated cold pans should be defrosted daily. Never use sharp objects or tools to clean or scrape ice/frost build up from the refrigerated cold pans. A puncture to the pan could cause irreparable damage to the refrigeration system. Units with a Eutectic Fluid Cold Pan require the same precautions. The fluid is NOT refillable and loss of fluid due to a puncture would cause irreparable damage.

CLEANING THE CONDENSER COIL

In order to maintain proper refrigeration performance, the condenser fins must be cleaned of dust, dirt and grease regularly. It is recommended that this be done monthly. If conditions are such that the condenser is totally blocked in a month, the frequency of cleaning should be increased. Clean the condenser with a vacuum cleaner or stiff brush. If extremely dirty, a commercially available condenser cleaner may be required.

Failure to maintain a clean condenser coil can initially cause high temperatures and excessive run times. Continuous operation with a dirty or clogged condenser coil can result in compressor failure. Neglecting the condenser coil cleaning procedures will void any warranties associated with the compressor and cost to replace the compressor.

N8100-FA SERIES DRAIN MAINTENANCE

Each N8100-FA unit has a drain located inside the unit that removes the condensation from the evaporator coil and routes it to an external condensate evaporator pan. Each drain can become loose or disconnected during normal use. If you notice water accumulation under the unit, be sure the drain tube is connected to the evaporator drain pan and the end of the drain tube is in the condensate evaporator. The leveling of the unit is important as the units are designed to drain properly when level. Be sure all drain lines are free of obstructions.

Section 5 Troubleshooting

Problem -> Cause -> Correction Chart

Problem	Cause	Correction
Not running	Fuse blown or circuit breaker tripped.	Replace fuse or reset circuit breaker.
	Power cord unplugged.	Plug in power cord. Power cord can also be unplugged from the unit. Check both ends
	Thermostat set too high.	Set thermostat to lower temperature.
	Main power switch turned off.	Turn main power switch on.
	Control is turned off - indicated by single blue dot.	Turn control on by holding down the power button (lower left button)
Condensing unit runs without cooling continuously	Dirty condenser coil.	Clean the condenser coil.
	Poor airflow to condenser coil or recirculation of condenser air back through the coil.	Provide fresh air to condenser. See installation instructions.
Temperature is too high	Thermostat set too high.	Set thermostat to lower temperature.
	Warm product placed in well.	Remove warm product and change with cold product, preferably 34°-36°.
	Dirty condenser coil.	Clean the condenser coil.
	Iced over.	Turn unit off and allow to defrost.
Food temping too high	Make sure food is cold before loading into well. Make sure no air is blowing onto well from vents or other equipment.	Stir food occasionally to help maintain product temp or change product when out of temp.
Cabinet is noisy	Loose part(s).	Locate and tighten loose part(s).
Refrigerator is freezing product	Thermostat is set too low.	Set thermostat to higher temperature.
	Product left in the well too long.	Remove product at night or change when out of temp. Stir food occasionally to help maintain product temp or change product when out of temp.
Compressor will not start	Low voltage to cabinet.	Check and correct incoming voltage to cabinet.
Compressor will not start and trips overload	Low pressure switch open (R290 units).	Check refrigerant level.
	Open compressor windings, locked rotor condition, or defective start components.	Check windings for open condition, check amp draw for locked rotor condition, if none of the above exist change start components.

Section 6

Refrigeration

R404A

Refrigerant Recovery / Evacuation & Recharging

Do not purge refrigerant to the atmosphere. Capture refrigerant using recovery equipment by specific manufacturer's recommendations.

Important

We assume no responsibility for the use of contaminated refrigerant. Damage resulting from the use of contaminated refrigerant is the sole responsibility of the servicing company.

Connections

1. Suction side of the compressor through the suction service valve.
2. Discharge side of the compressor through the discharge service valve.

Self-Contained Recovery/Evacuation

1. Disconnect power to the unit.
2. Install manifold gauges, charging cylinder/scale, and recovery unit or two-stage vacuum pump.
3. Perform recovery or evacuation:
 - H. Recovery: Operate the recovery unit as directed by the manufacturer's instructions.
 - I. Evacuation prior to recharging:
Pull the system down to 250 microns. Then, allow the pump to run for an additional half hour. Turn off the pump and perform a standing vacuum leak check.

NOTE: Check for leaks using halide or electronic leak detector after charging the Reach-In.

Charging Procedures

Important

The charge is critical on all Reach-In units. Use a scale or a charging cylinder to ensure the proper charge is installed.

1. Disconnect power to the unit.
2. Close the vacuum pump valve, the low side service valve, and the low side manifold gauge valve.
3. Open the high side manifold gauge valve and the high side service valve.
4. Open the charging cylinder and add the proper refrigerant charge (shown on nameplate) through the discharge service valve.
5. Let the system "settle" for 2 to 3 minutes.
6. Connect power up the unit.
7. Close the high side valve on the manifold gauge set. Add any remaining vapor charge through the suction service valve (if necessary).

NOTE: Manifold gauges must be removed properly to ensure that no refrigerant contamination or loss occurs.

8. Make sure that all the vapor in the charging hoses is drawn into the Reach-In before disconnecting the charging hoses.
 - A. Run the Reach-In cooling mode.
 - B. Close the high side service valve at the Reach-In.
 - C. Open the low side service valve at the Reach-In.
 - D. Open the high and low side valves on the manifold gauge set. Any refrigerant in the lines will be pulled into the low side of the system.
 - E. Allow the pressures to equalize while the Reach-In is running.
 - F. Close the low side service valve at the Reach-In.
 - G. Remove the hoses from the Reach-In and install the caps.

System Contamination Clean-up

This section describes the basic requirements for restoring contaminated systems to reliable service.

Important

We assume no responsibility for the use of contaminated refrigerant. Damage resulting from the use of contaminated refrigerant is the sole responsibility of the servicing company.

Determining Severity Of Contamination

Either moisture or residue generally causes system contamination from compressor burnout entering the refrigeration system.

Inspection of the refrigerant usually provides the first indication of system contamination. Obvious moisture or an acrid odor in the refrigerant indicates contamination.

If either condition is found, or if contamination is suspected, use a Total Test Kit from Totaline or a similar diagnostic tool. Follow the manufacturer's directions. These devices sample refrigerant, eliminating the need to take an oil sample.

If a refrigerant test kit indicates harmful levels of contamination, or if a test kit is not available, inspect the compressor oil.

1. Remove the refrigerant charge from the Reach-In.
2. Remove the compressor from the system.
3. Check the odor and appearance of the oil.
4. Inspect the suction and discharge lines at the compressor for burnout deposits.
5. If no signs of contamination are present, perform an acid oil test.

Check the chart below to determine the type of cleanup required.

Contamination/Clean-up Chart	
Symptoms/Findings	Required Cleanup Procedure
No Symptoms or suspicion of contamination	Normal evacuation/recharging procedure
Moisture/Air Contamination symptoms <ul style="list-style-type: none"> • Refrigeration system open to atmosphere for prolonged periods • Refrigeration test kit and/or acid oil test shows contamination <ul style="list-style-type: none"> • Leak in water-cooled condenser • No burnout deposits in open compressor lines 	Mild contamination clean-up procedure
Mild Compressor Burnout symptoms <ul style="list-style-type: none"> • Oil appears clean but smells acrid • Refrigeration test kit or acid oil test shows harmful acid content <ul style="list-style-type: none"> • No burnout deposits in open compressor lines 	Mild contamination clean-up procedure
Severe Compressor Burnout symptoms <ul style="list-style-type: none"> • Oil is discolored and smells acrid • Refrigeration test kit or acid oil test shows harmful acid content • Burnout deposits found in the compressor and lines, and in other components 	Severe contamination clean-up procedure

Mild System Contamination Clean-Up Procedure

1. Replace any failed components.
2. If the compressor is good, change the oil.
3. Replace the liquid line drier.

NOTE: If the contamination is from moisture, use heat lamps during evacuation. Position them at the compressor, condenser and evaporator prior to evacuation.

Important

Dry nitrogen is recommended for this procedure. This will prevent CFC release.

4. Follow the normal evacuation procedure, except replace the evacuation step with the following:
 - A. Pull vacuum to 1000 microns. Break the vacuum with dry nitrogen and sweep the system. Pressurize to a minimum of 5 PSI.
 - B. Pull vacuum to 500 microns. Break the vacuum with dry nitrogen and sweep the system. Pressurize to a minimum of 5 PSI.
 - C. Change the vacuum pump oil.
 - D. Pull vacuum to 250 microns. Run the vacuum pump for ½ hour on self-contained models, 1 hour on remotes.

NOTE: You may perform a standing vacuum test to make a preliminary leak check. You should use an electronic leak detector after system charging to be sure there are no leaks.

5. Charge the system with the proper refrigerant to the nameplate charge.
6. Operate the Reach-In unit.

Severe System Contamination Clean-Up Procedure

1. Remove the refrigerant charge.
2. Remove the compressor.
3. Remove the liquid line drier.
4. Replace the capillary tube.
5. Wipe away any burnout deposits from suction and discharge lines at compressor.
6. Sweep through the open system with dry nitrogen.

Important

Refrigerant sweeps are not recommended, as they release CFC's into the atmosphere.

7. Install a new compressor and new start components.
8. Install a suction line filter-drier (with acid and moisture removal capability) of adequate size. Place the filter drier as close to the compressor as possible.
9. Install inlet and outlet access valves.
10. Install a new liquid line drier.
11. Follow the normal evacuation procedure, except replace the evacuation step with the following:
 - A. a) Pull vacuum to 1000 microns. Break the vacuum with dry nitrogen and sweep the system. Pressurize to a minimum of 5 PSI.
 - B. Change the vacuum pump oil.
 - C. Pull vacuum to 500 microns. Break the vacuum with dry nitrogen and sweep the system. Pressurize to a minimum of 5 PSI.
 - D. Change the vacuum pump oil.
 - E. Pull vacuum to 250 microns. Run the vacuum pump for ½ hour on self-contained models, 1 hour on remotes.

NOTE: You may perform a standing vacuum test to make a preliminary leak check. You should use an electronic leak detector after system charging to be sure there are no leaks.

12. Charge the system with the proper refrigerant to the nameplate charge.
13. Operate the Reach-In unit for one hour. Then check the pressure drop across the suction line filter-drier.
 - A. If the pressure drop is less than 1 PSI, the filter-drier should be adequate for complete clean up.
 - B. If the pressure drop exceeds 1 PSI, change the suction line filter-drier and the liquid line drier.

Repeat steps 8 through 13 until the pressure drop is acceptable.

14. Operate the Reach-In unit for 48-72 hours. Then remove the suction line filter-drier and change the liquid line drier.
15. Follow normal evacuation procedures.

Filter Driers

The size of the filter-drier is important. Using an improperly sized filter-drier will cause the Reach-In unit to be improperly charged with refrigerant.

Important

Driers are covered as a warranty part. Driers must be replaced any time the system is opened for repairs.

Section 7

Component Check Procedures

Mechanical Refrigeration Control

Mechanical controls will have a capillary line that goes into a tube connected to the suction line coming from the cold well. As temperature increases a gas inside the capillary expands and forces a bellows to close the contacts. As temperature decreases the gas will contract and cause the contacts to open. Contacts send power to the compressor and condenser motor when closed.

Electric/Solid State Refrigeration Control

Electric/solid state control requires a power supply for the control to operate. The control has a sensor that reads suction line temperature in the well. A set of contacts in the control will open or close depending on temperature of the suction line and the ohm reading from the sensor. There will be a delay on power up before the contacts close and a delay between cycles. Contacts send power to the compressor and condenser motor when closed.

Unit Air Flow Design

SELF-CONTAINED REFRIGERATED DROP-IN UNITS & SELF-CONTAINED COMBO HOT/COLD DROP-IN UNITS

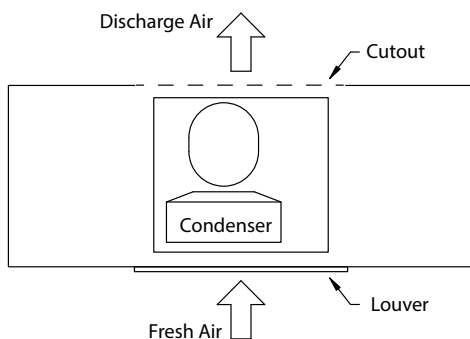

FORCED-AIR REFRIGERATED DROP-IN UNITS

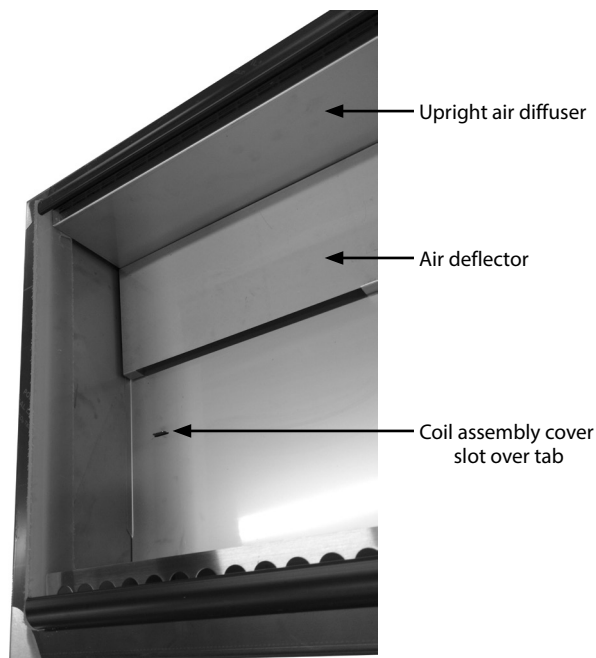
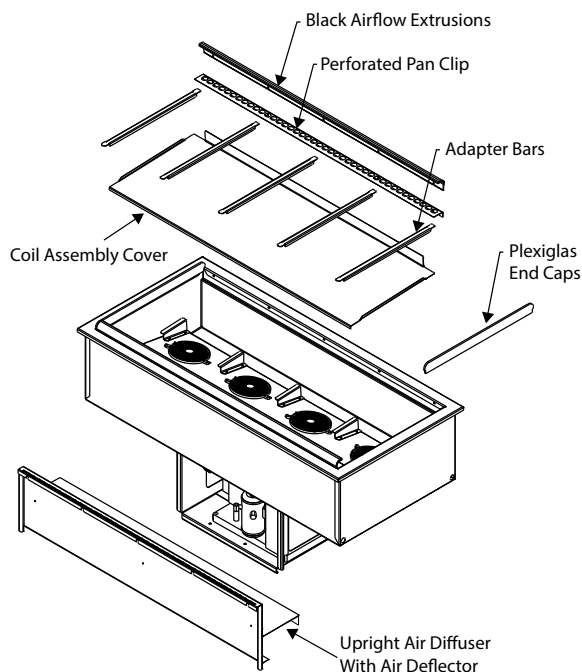

- The coil assembly cover has slots to be set over tabs. This will hold the cover in place, allowing proper air flow.
- The upright air diffuser with air deflector also facilitate proper air flow.

Section 8 Wiring Diagrams

Drop-In Series 8100-EF & 8100-EFN

NOTE: Built after 6-1-17.

Control Diagram

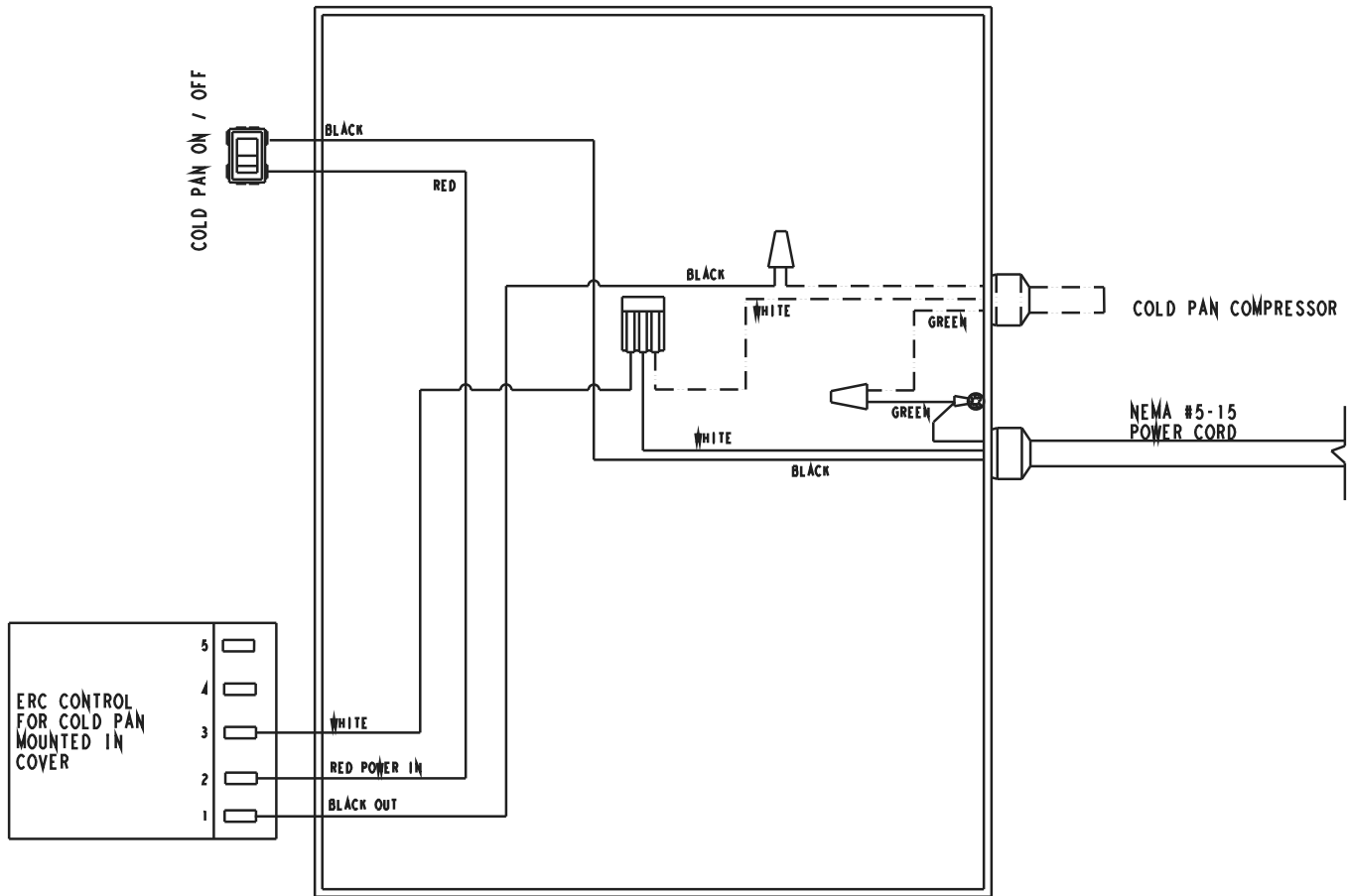

Drop-In Series 8100-EF & 8100-EFN

NOTE: Built after 6-1-17.

Compressor Diagram

Models 8118-EF, 8132-EF, 8145-EF, 8159-EF, 8172-EF, 8148-EFN, 8169-EFN, 8191-EFN

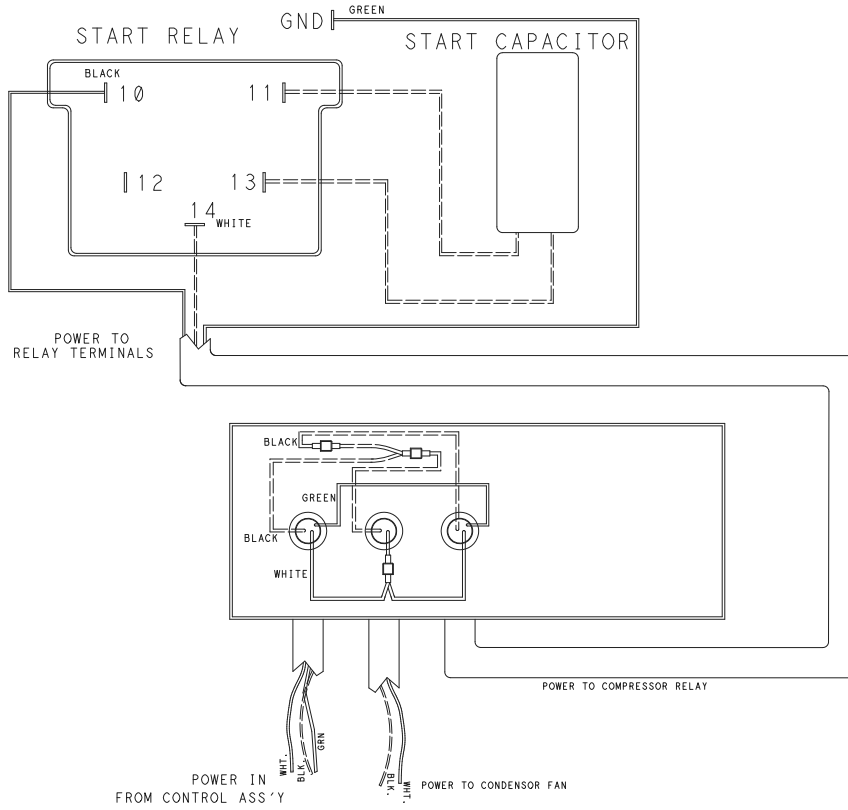

Model 8186-EF

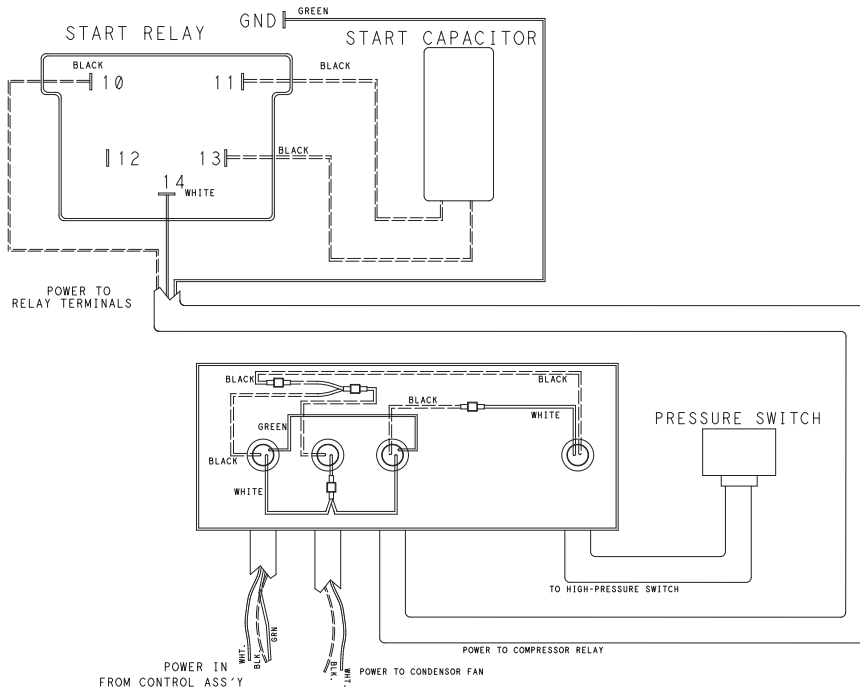

Drop-In Series 8100-EF & 8100-EFN

NOTE: Built before 6-1-17.

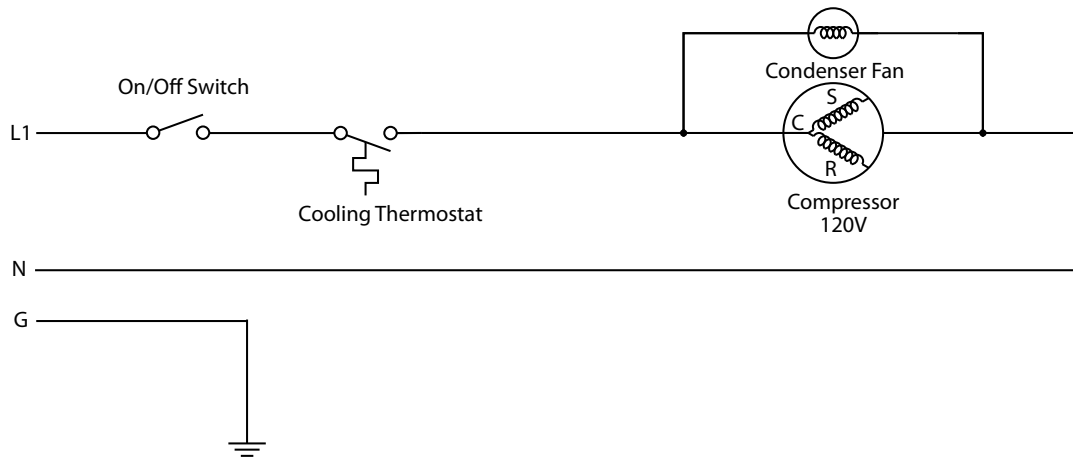

Export Drop-In Series 8100-EF-E & 8100-EFN-E

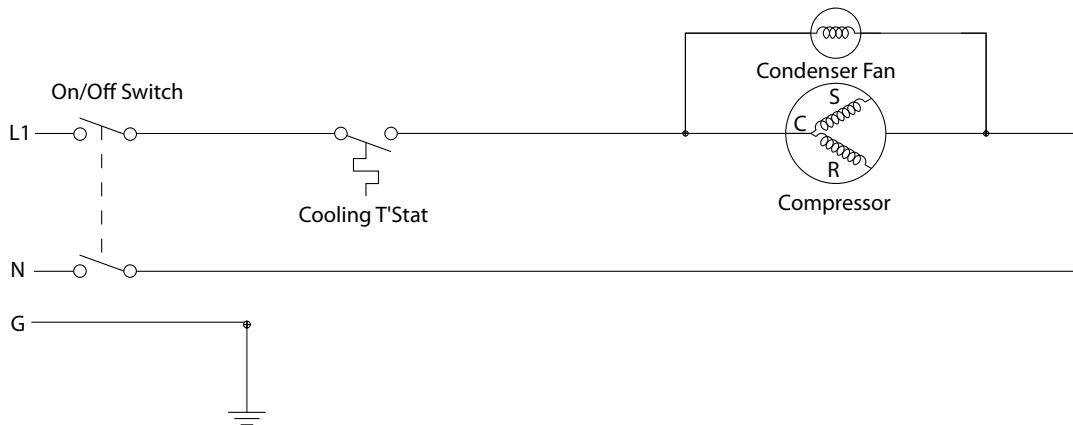

Drop-In Series N8100B, N8100NB & N8100-BR

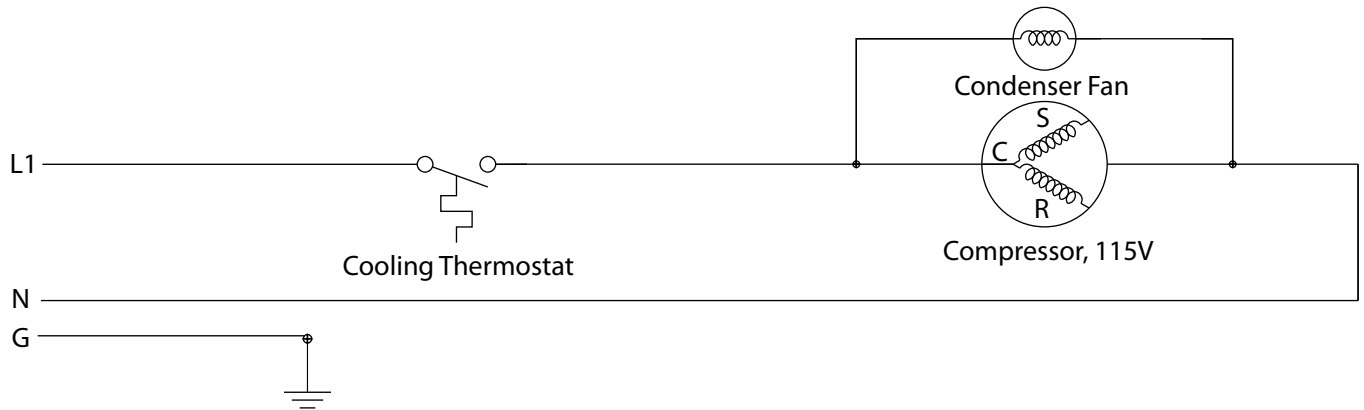

Export Drop-In Series N8100B-E & N8100NB-E

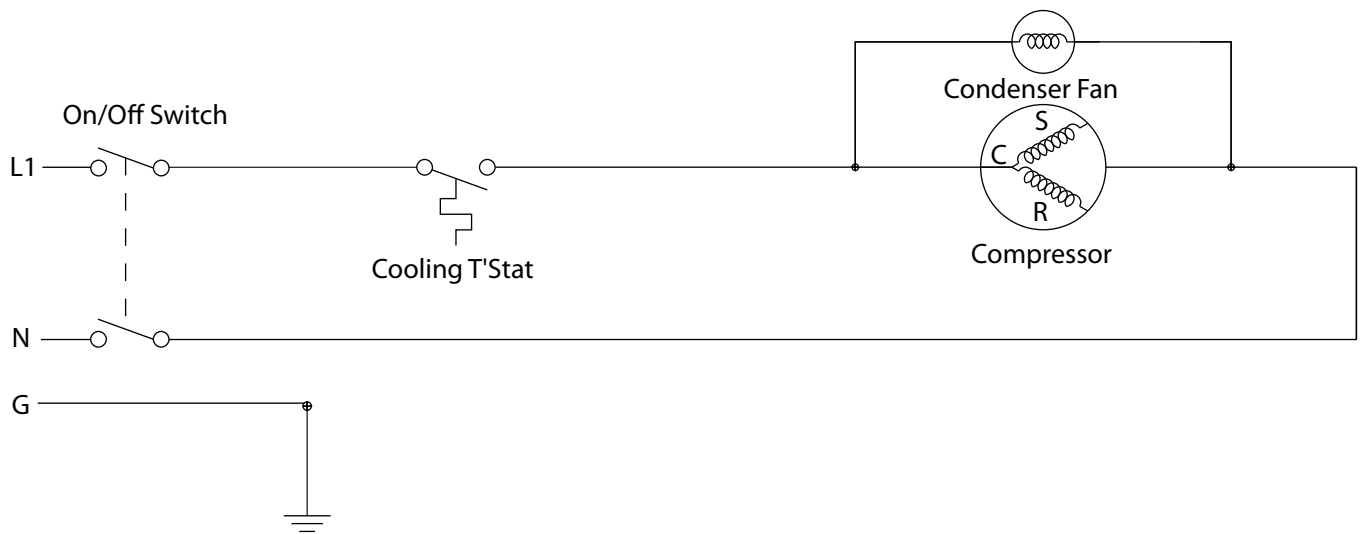

N8100-FA Series Models

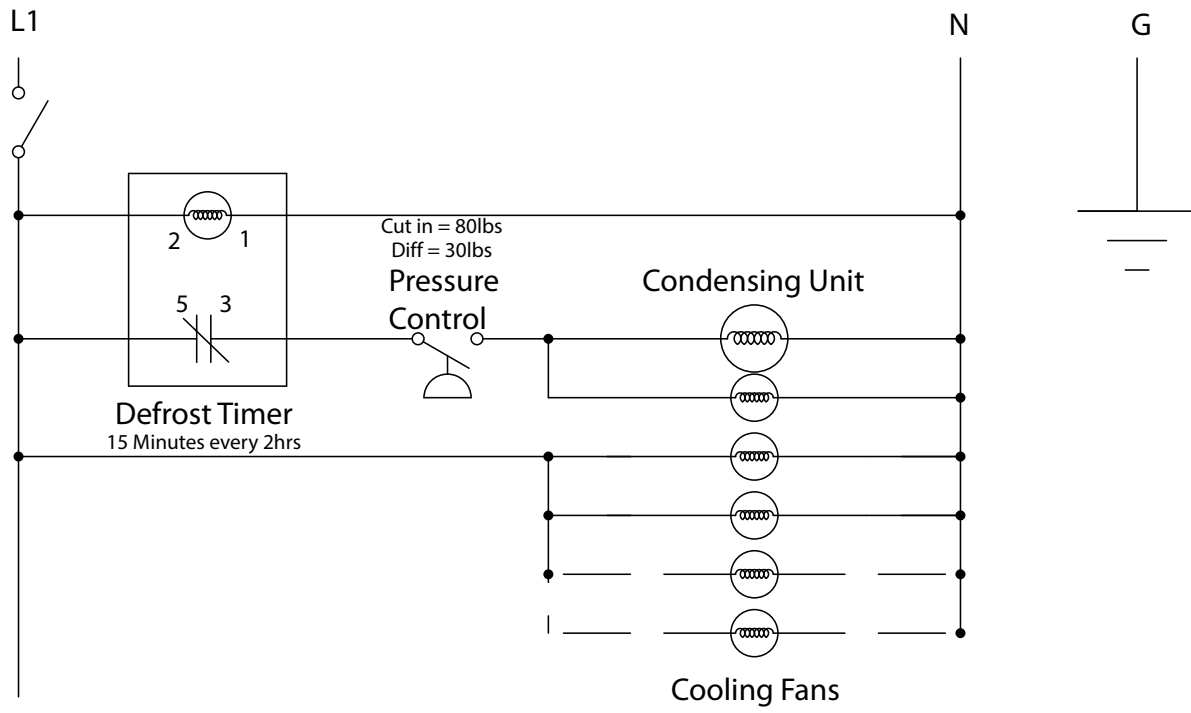

Drop-In Frost Tops Series N8200 & N8200-ST

Drop-In Granite Cold Slabs Series N8200G

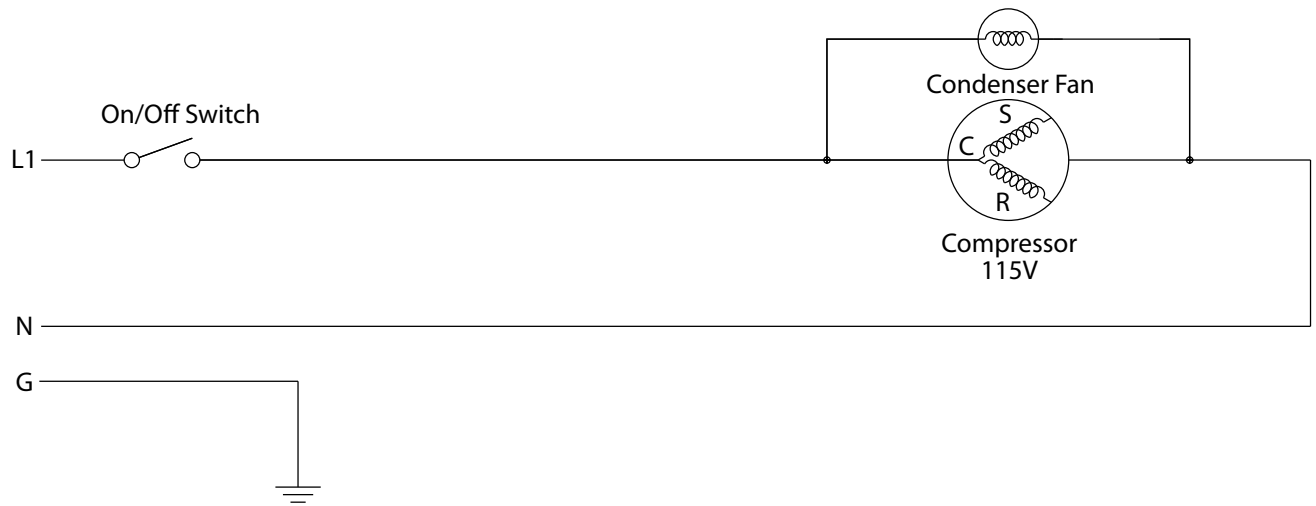

Export Drop-In Frost Tops Series N8200-E

Export Drop-In Granite Cold Slabs Series N8200G-E

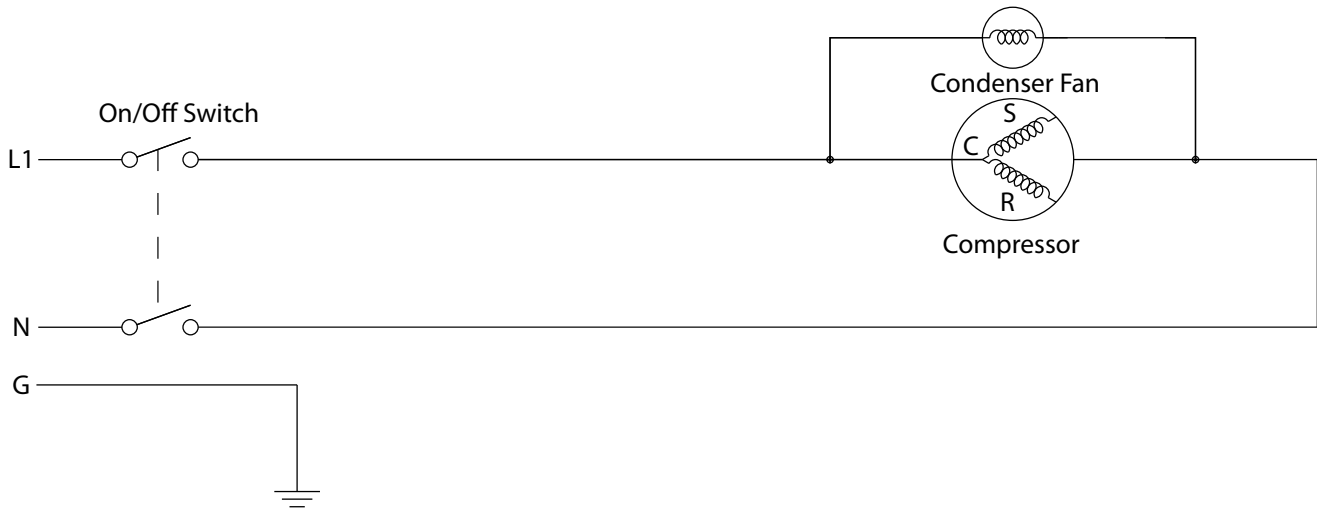

N8600 Series

Model N8630

120V-1PH-3KW HEATER

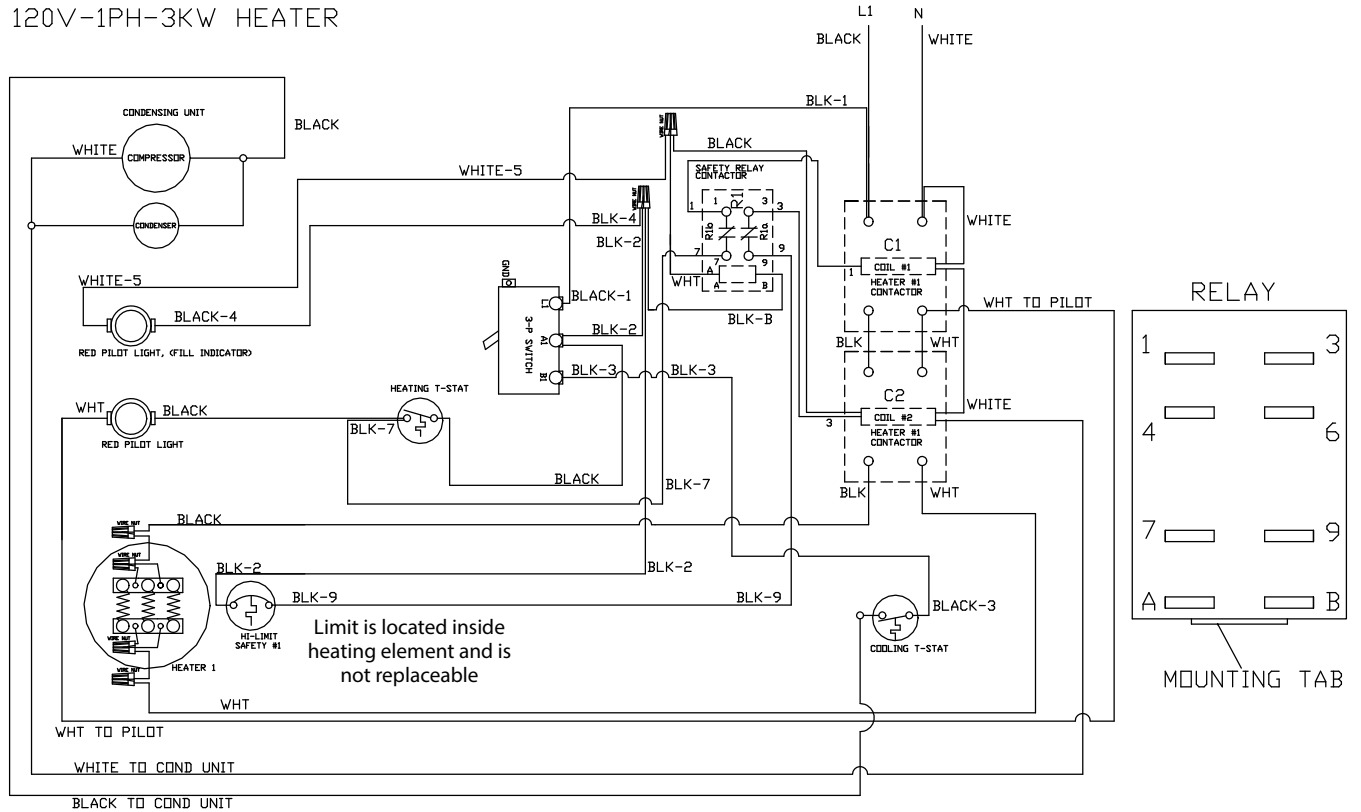

Models N8643 & N8656

120/208V-1PH-5KW HEATER OR
120/240V-1PH-5KW HEATER

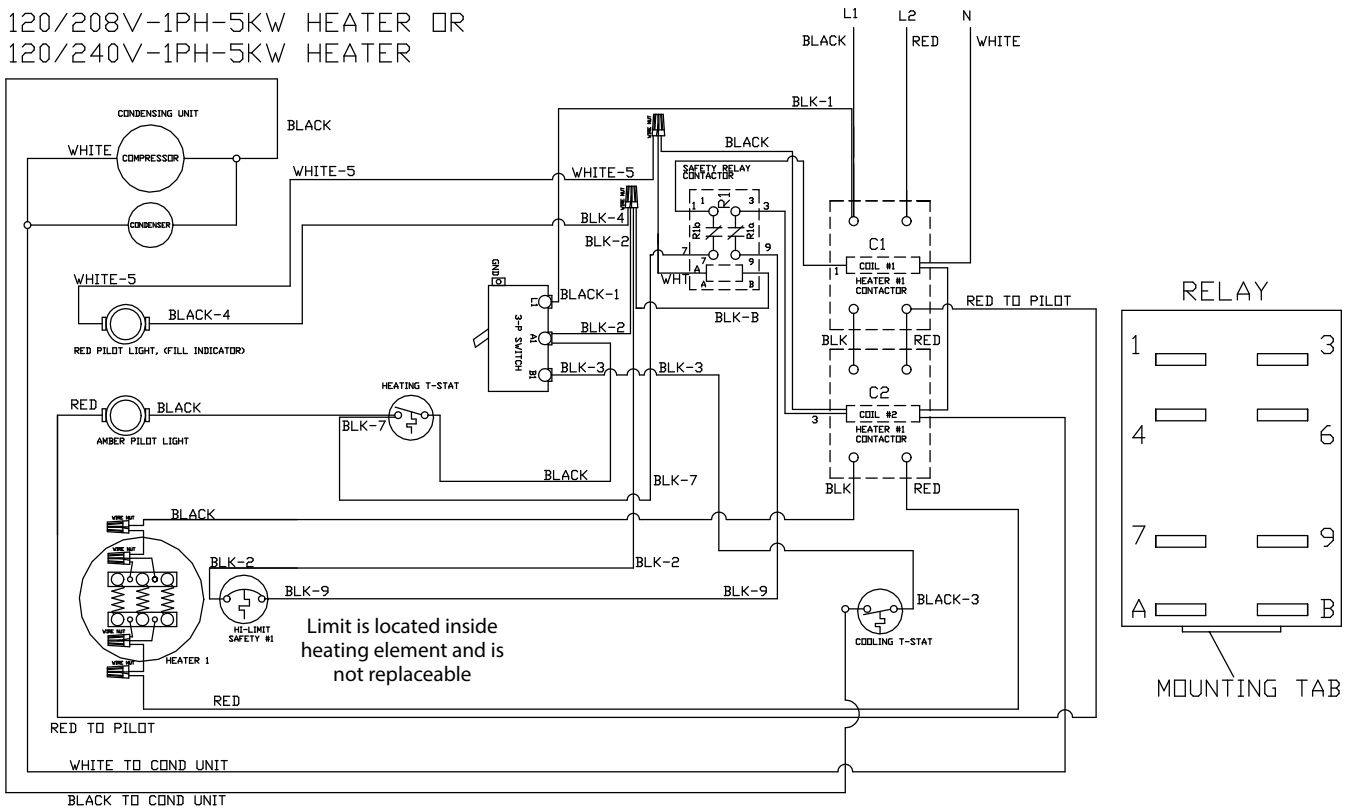

Models N8669 & N8681

120/208V-1PH-(2) 5KW HEATER OR
 120/240V-1PH-(2) 5KW HEATER

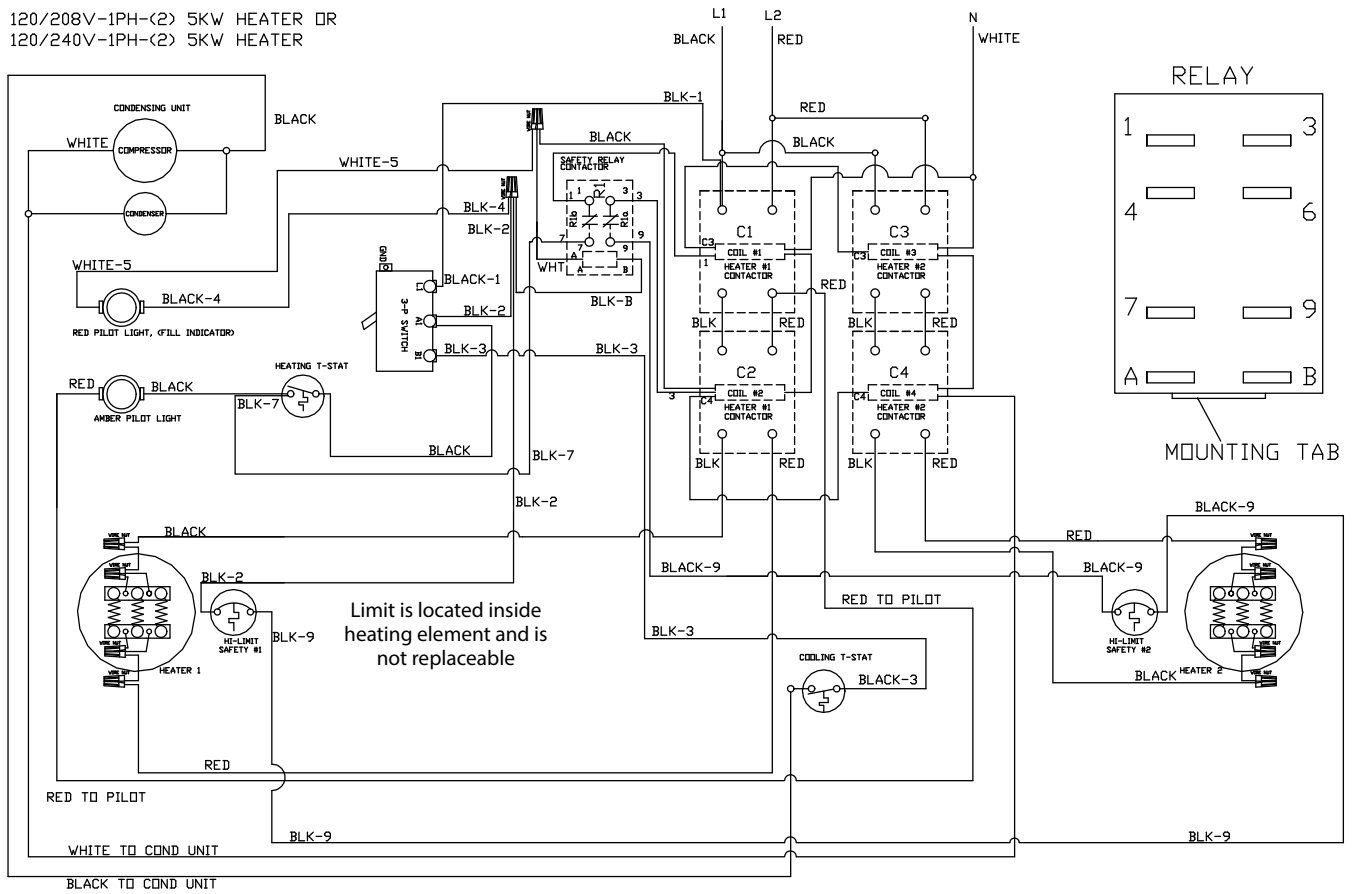

N8700D, N8700DESP, N8700-R & N8700N Series

Models with Energy Savings Power (ESP)/Low Watt Heating Elements

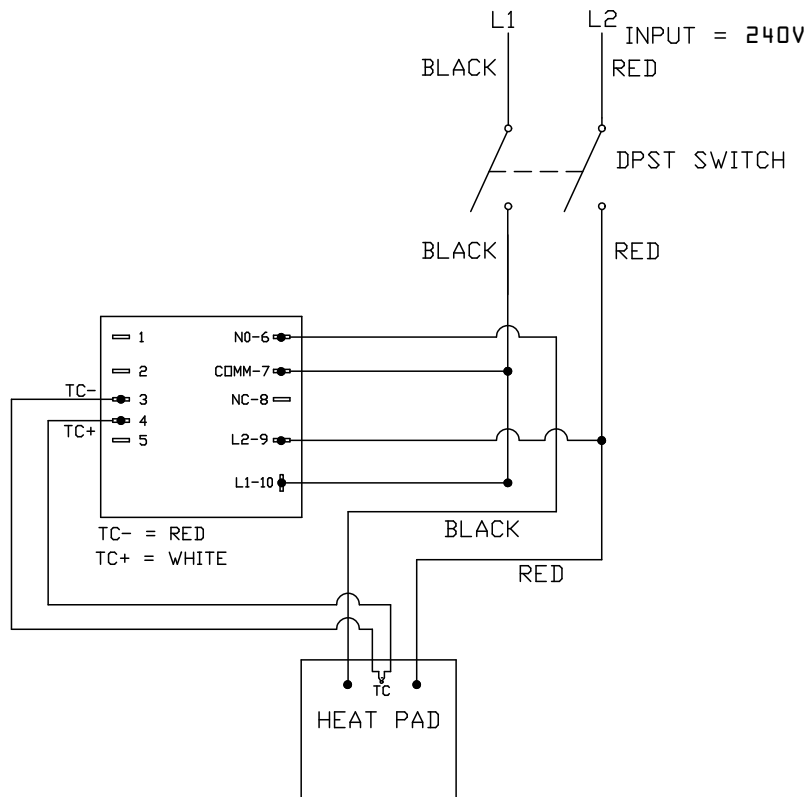

Service Notes

- The temperature probes (thermocouples) are mounted directly to the heat pad and can only be tested with a meter that can read type J thermocouples. When testing the thermocouple read the temperature of the hot food well to determine what the mV reading should be.
- When replacing the well not to apply pressure directly to the pad.
- Heater Resistance: 240 Volt Heaters Min 109.20 ~ Max 120.80

Models with 208-230 Voltage, 60 Cycle, 3 Phase

30A, 3-POLE 3 PHASE

BLACK RED BLUE

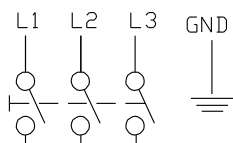

NEUTRAL WIRE FOR 120 VOLT OPTIONS
NEUTRAL _____

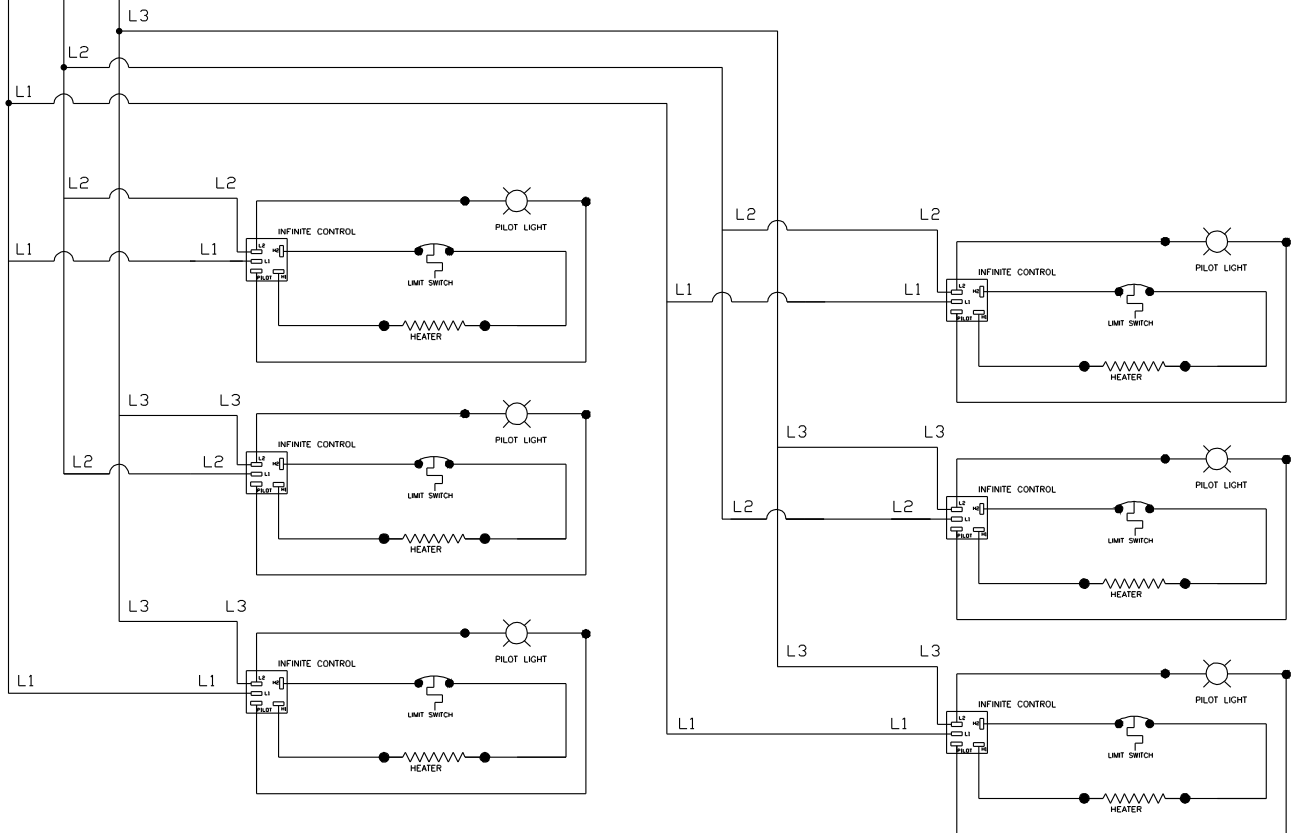
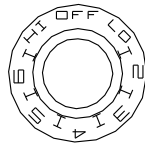

# of Food Wells	Amperes In Line Wires		
	208-230V, 3 Phase		
	Line1	Line2	Line3
2	6.0/7.3	3.0/3.6	3.0/3.6
3	9.0/11.0	9.0/11.0	9.0/11.0
4	9.0/11.0	9.0/11.0	6.0/7.3
5	17.0/20.0	9.0/11.0	9.0/11.0
6	17.0/20.0	17.0/20.0	17.0/20.0

Models with 240 Volt, 50 Cycle, 1 Phase

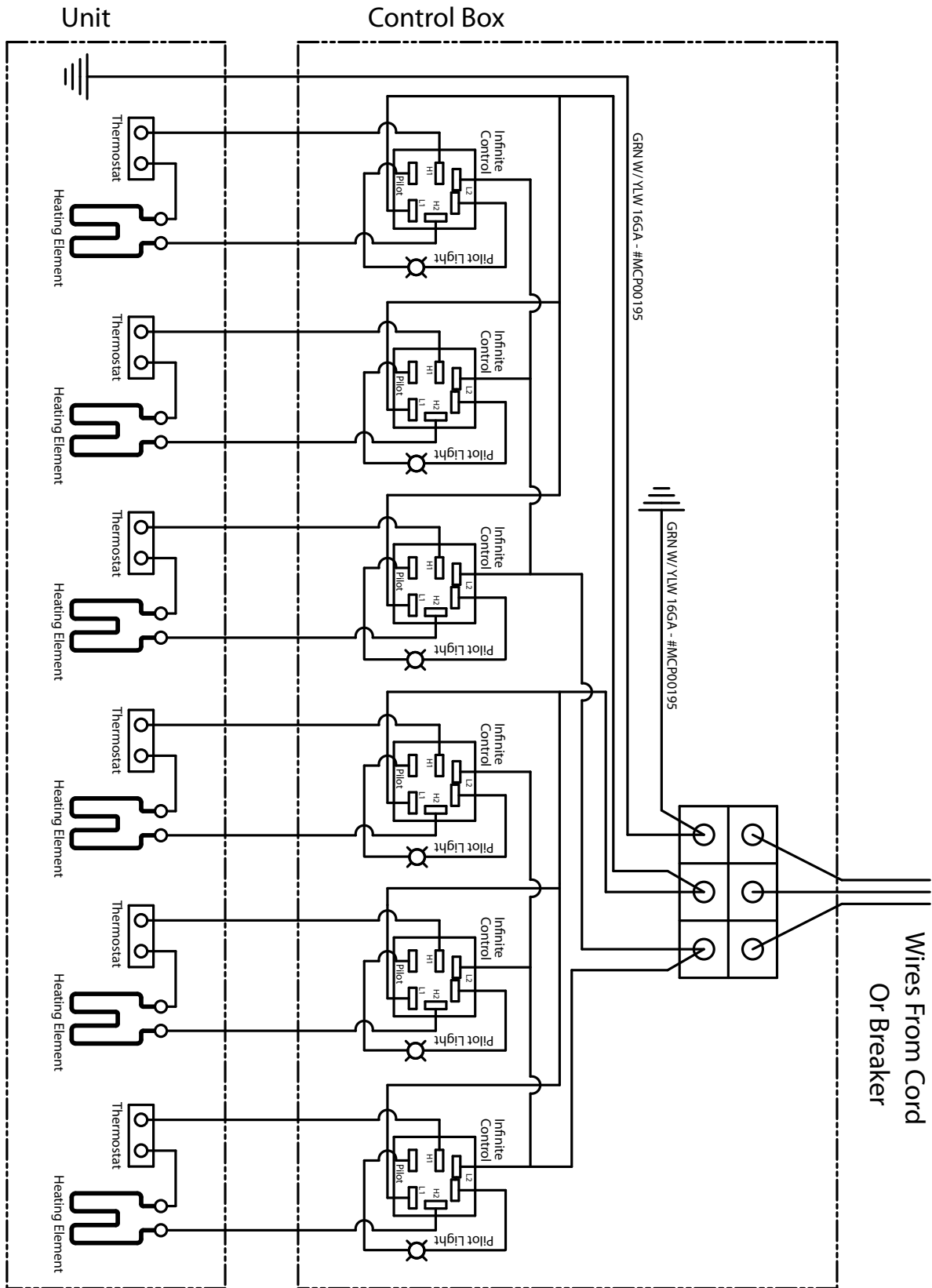

8700UM Series Models

120 Volt Models

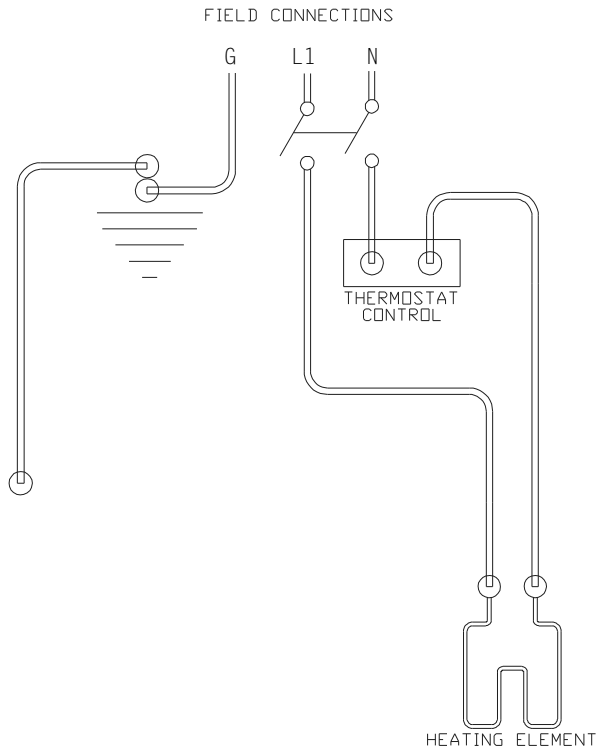

240 Volt Models

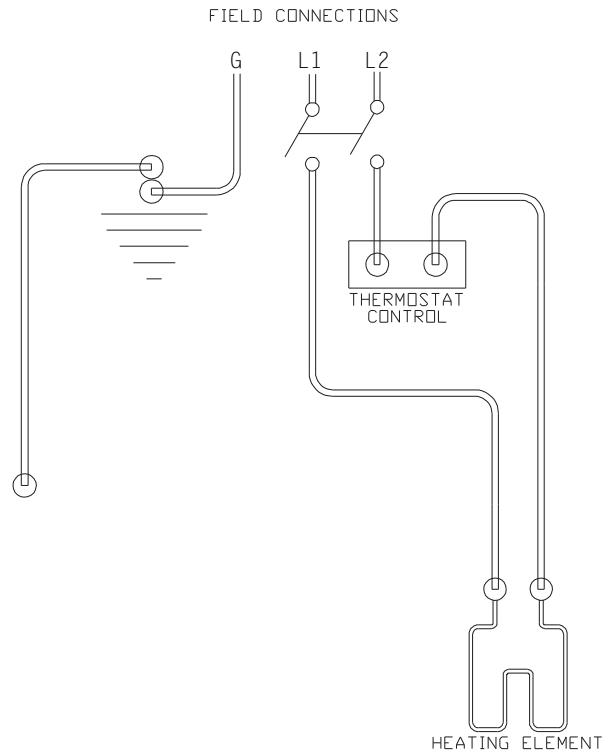

N8800 Series Models

120Volt, 60Hertz, 1 Phase

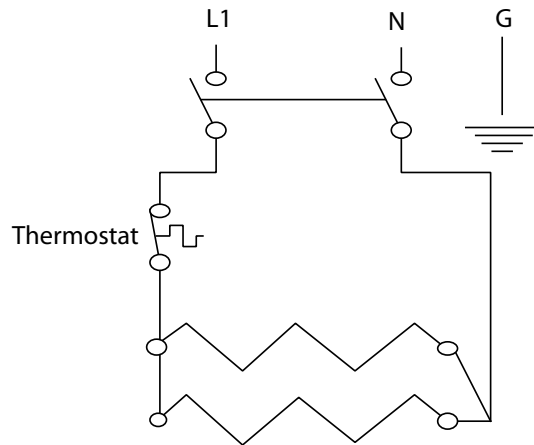

208-230Volt, 60Hertz, 1 Phase

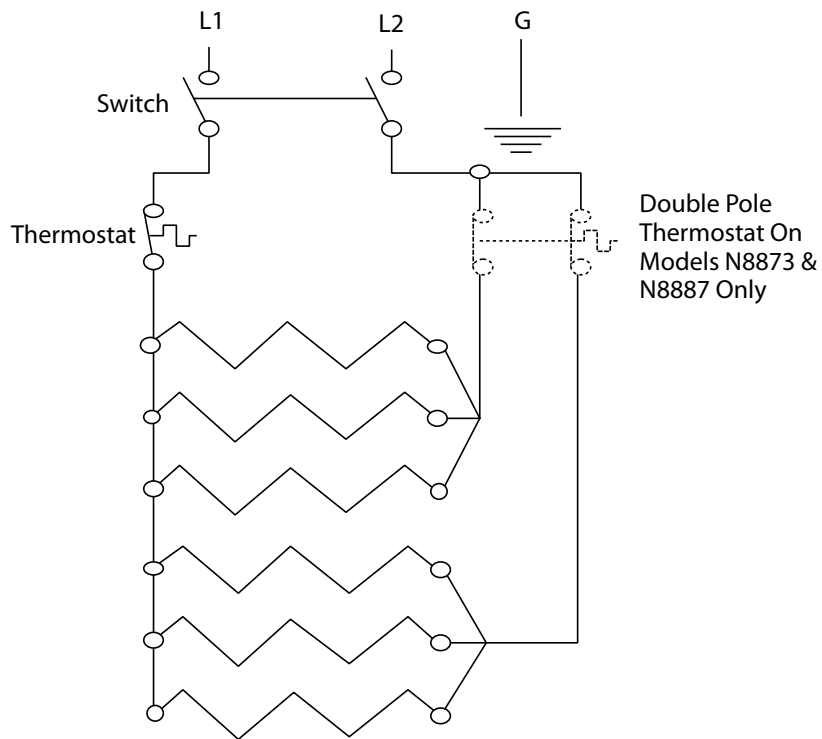

240Volt, 50Hertz, 1 Phase

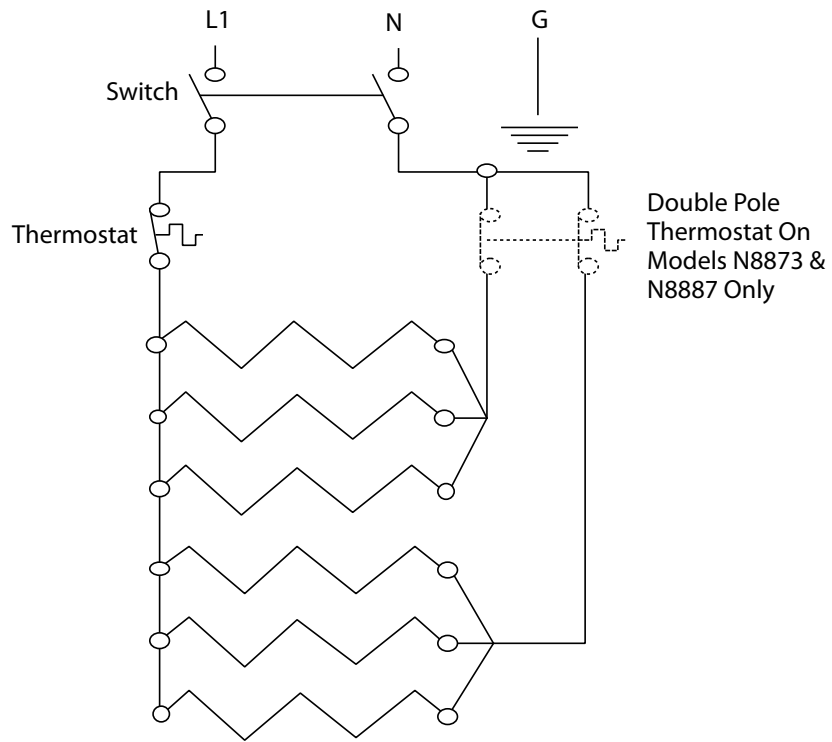

Section 9

Replacement Procedures

Plumbing

Depending on site access unit may need to be removed from counter to do plumbing repairs. Close drain valve and fill well with water to leak check before returning hot well to service.

Wiring

If replacing any wiring or connectors use wire and connectors of the same size/rating.

**WWW.WELBILT.COM**

Welbilt provides the world's top chefs, and premier chain operators or growing independents with industry leading equipment and solutions. Our cutting-edge designs and lean manufacturing tactics are powered by deep knowledge, operator insights, and culinary expertise. All of our products are backed by KitchenCare® – our aftermarket, repair, and parts service.

- ▶ CLEVELAND
- ▶ CONVOTHERM®
- ▶ DELFIELD®
- ▶ FITKITCHEN™
- ▶ FRYMASTER®
- ▶ GARLAND
- ▶ KOLPAK®
- ▶ LINCOLN
- ▶ MANITOWOC®
- ▶ MERCO®
- ▶ MERRYCHEF®
- ▶ MULTIPLEX®

