

# 18600 Series & CTP-NB

## Refrigerated Prep Tables, Work Tables & Rails

### Original Instructions

### Installation, Operation and Maintenance Manual

This manual is updated as new information and models are released. Visit our website for the latest manual.



 **Caution**

Read this instruction before operating this equipment.

## Safety Notices

### **Warning**

Read this manual thoroughly before operating, installing or performing maintenance on the equipment. Failure to follow instructions in this manual can cause property damage, injury or death.

### **DANGER**

Do not install or operate equipment that has been misused, abused, neglected, damaged, or altered/modified from that of original manufactured specifications.

### **DANGER**

All utility connections and fixtures must be maintained in accordance with local and national codes.

### **DANGER**

Use appropriate safety equipment during installation and servicing.

### **Warning**

Do not damage the refrigeration circuit when installing, maintaining or servicing the unit.

### **Warning**

Authorized service representatives are obligated to follow industry standard safety procedures, including, but not limited to, local/national regulations for disconnection / lock out / tag out procedures for all utilities including electric, gas, water and steam.

### **Warning**

Do not store or use gasoline or other flammable vapors or liquids inside or within the vicinity of this or any other appliance. Never use flammable oil soaked cloths or combustible cleaning solutions, for cleaning.

### **Warning**

This product contains chemicals known to the State of California to cause cancer and/or birth defects or other reproductive harm. Operation, installation, and servicing of this product could expose you to airborne particles of glasswool or ceramic fibers, crystalline silica, and/or carbon monoxide. Inhalation of airborne particles of glasswool or ceramic fibers is known to the State of California to cause cancer. Inhalation of carbon monoxide is known to the State of California to cause birth defects or other reproductive harm.

### **Warning**

Do not use electrical appliances inside the food storage compartments of the appliance, unless they are of the type recommended by the manufacturer.

### **Warning**

Use caution when handling metal surface edges of all equipment.

### **Warning**

This appliance is not intended for use by persons (including children) with reduced physical, sensory or mental capabilities, or lack of experience and knowledge, unless they have been given supervision concerning use of the appliance by a person responsible for their safety. Do not allow children to play with this appliance.

### **Caution**

Use caution handling, moving and use of the R290 refrigerators to avoid either damaging the refrigerant tubing or increasing the risk of a leak. Components shall be replaced with like components. Servicing shall be done by a factory authorized service personnel to minimize the risk of possible ignition due to incorrect parts or improper service.

### **Notice**

Proper installation, care and maintenance are essential for maximum performance and trouble-free operation of your equipment. Visit our website [www.wbtkitchenare.com](http://www.wbtkitchenare.com) for manual updates, translations, or contact information for service agents in your area.

### **Notice**

Warranty may be deemed invalid if other than authorized OEM (original equipment manufacture) replacement parts are used in Delfield equipment.

### **Notice**

These appliances are intended to be used for commercial applications, for example in kitchens of restaurants, canteens, hospitals and in commercial enterprises such as bakeries, butcheries, etc., but not for continuous mass production of food.

### **Notice**

Climatic class 4 is defined as ambient conditions of 30°C and 55% relative humidity, according to ISO 23953-2.

### **Notice**

This product utilizes Ecomate blowing agent methyl formate

# Table of Contents

---

## Section 1

### General Information

Model Numbers .....	5
Serial Number Information.....	5
Warranty Information.....	5
Regulatory Certifications .....	6
Standard Models .....	6
Export Options .....	6

## Section 2

### Installation

Location .....	7
Weight Of Equipment .....	8
Clearance Requirements.....	8
Dimensions .....	8
Capacity .....	9
Electrical Service .....	11
Drain Connections .....	12
Leg & Caster Installation.....	12
Refrigeration .....	13
18600PTB Cutting Board Installation.....	14

## Section 3

### Operation

CTP-NB Series, Countertop Prep Rail.....	16
Refrigerated Work Tables.....	16
Refrigerated Rails .....	16
Work Table Evaporator Fan Operation .....	16
PTLV Pressure Control.....	16
115Volt Work Table Control Assemblies.....	17
At Start Up.....	17
ERC112 Temperature Control.....	18
Changing Display from Fahrenheit to Celsius on ERC112 Control.....	19
230-240Volt Export Work Table Controls.....	20
Export Temperature Control .....	20
Export 230-240 Volt Pressure Control.....	20
PTB-E & PTL-E High Pressure Limiting Device .....	20

## Section 4

### Maintenance

General Cleaning .....	21
Interior Cleaning.....	22
Gaskets.....	22
Preventing Blower Coil Corrosion .....	22
Exterior Cleaning .....	22
Drain.....	22
Drawer Assembly Cleaning .....	23
Doors .....	23
Cleaning The Condenser Coil .....	23

**Section 5  
Diagrams**

SMART Scale options..... 24

# Section 1

## General Information

### Model Numbers

This manual covers the following self contained work tables:

Standard Model	Model with Export Option
<b>Refrigerated Work Table With Backsplash</b>	
18648BSTMP	18648BST-E
18660BSTMP	18660BST-E
18672BSTMP	18672BST-E
18691BSTMP	18691BST-E
18699BSTMP	18699BST-E
186114BSTMP	186114BST-E
<b>Refrigerated Work Table</b>	
18648BUCMP	18648BUC-E
18660BUCMP	18660BUC-E
18672BUCMP	18672BUC-E
18691BUCMP	18691BUC-E
18699BUCMP	18699BUC-E
186114BUCMP	186114BUC-E
<b>Refrigerated Pizza Prep Table With Raised Rail</b>	
18648PTBMP	18648PTB-E
18660PTBMP	18660PTB-E
18672PTBMP	18672PTB-E
18691PTBMP	18691PTB-E
18699PTBMP	18699PTB-E
186114PTBMP	186114PTB-E
<b>Refrigerated Pizza Prep Table With Raised Rail With Smart Scale</b>	
18648PTBMP-SMT	-
18660PTBMP-SMT	-
18672PTBMP-SMT	-
18691PTBMP-SMT	-
18699PTBMP-SMT	-
186114PTBMP-SMT	-
<b>Refrigerated Pizza Prep Table With LiquiTec® Rail - R290</b>	
18648PTLP	-
18672PTLP	-
18699PTLP	-
<b>Refrigerated Pizza Prep Table With LiquiTec® Rail - R290 With Smart Scale</b>	
18648PTLP-SMT	-
18672PTLP-SMT	-
18699PTLP-SMT	-
<b>Refrigerated Pizza Prep Table With Dual LiquiTec® Rails - R290</b>	
18648PDLP	-
18672PDLP	-
<b>Refrigerated Pizza Prep Table With LiquiTec® Rail - R404a</b>	
18648PTLV	18648PTL-E
18672PTLV	18672PTL-E
18699PTLV	18699PTL-E
<b>Refrigerated Pizza Prep Table With Dual LiquiTec® Rails - R404a</b>	
18648PDLV	-
18672PDLV	-
<b>Refrigerated Countertop Prep Rail</b>	
CTP8146-NB	CTP8146-NB-E
CTP8160-NB	CTP8160-NB-E

Smart Scale EVO Tablet Options
EVO Tablet
Wall Mounted Bracket Assembly for EVO Tablet
Cover Mounted Bracket for EVO Tablet

### Serial Number Information

The serial number is on the identification plate that also includes the model number.

- The I.D. plate on all 18600 series units is located inside the compressor section.
- The I.D. plate on CTP-NB Series units is located on the front of the unit.

**Always have the serial number of your unit available when calling for parts or service.**

### Warranty Information

Visit [www.delfield.com/warranty](http://www.delfield.com/warranty) to:

- Register your product for warranty.
- Verify warranty information.
- View and download a copy of your warranty.



### Service

For parts and service consult Welbilt KitchenCare at 1-844-724-CARE

## Regulatory Certifications



### STANDARD MODELS

115Volt, 60Hertz, 1Phase models are certified by:

-  National Sanitation Foundation (NSF)
-  Underwriters Laboratories (UL)
-  Underwriters Laboratories of Canada (cUL)

### EXPORT OPTIONS

230-240Volt, 50Hertz, 1Phase models are certified by:

-  National Sanitation Foundation (NSF)
-  Technical Inspection Association
-  European Conformity

## Section 2 Installation

### **⚠ DANGER**

Installation must comply with all applicable fire and health codes in your jurisdiction.

### **⚠ DANGER**

Use appropriate safety equipment during installation and servicing.

### **⚠ Warning**

Remove all removable panels before lifting and installing.

### **⚠ Warning**

Do not damage the refrigeration circuit when installing, maintaining or servicing the unit.

### **⚠ Caution**

When adding any item verify the location of the refrigeration lines on wrapped rail units. A refrigeration leak in a rail may be irreparable or extremely difficult and costly to repair.

### **Location**

### **⚠ Warning**

This equipment must be positioned so that the plug is accessible unless other means for disconnection from the power supply (e.g., circuit breaker or disconnect switch) is provided.

### **⚠ Warning**

These appliances are to be connected with flexible connections for equipotential bonding and connection to services such as electricity supply, water supply, gas supply, and steam supply such that the appliance can be moved in the direction required for cleaning a distance not less than the dimension of the application in the direction of movement plus 500mm without the flexible connections becoming taught or being subject to strain.

### **⚠ Warning**

To avoid instability the installation area must be capable of supporting the combined weight of the equipment and product. Additionally the equipment must be level side to side and front to back.

### **⚠ Warning**

This equipment is intended for indoor use only. Do not install or operate this equipment in outdoor areas.

### **⚠ Caution**

Do not position the air intake vent near steam or heat exhaust of another appliance.

The location selected for the equipment must meet the following criteria. If any of these criteria are not met, select another location.

- Units are intended for indoor use only.
- The location **MUST** be level, stable and capable of supporting the weight of the equipment.
- The location **MUST** be free from and clear of combustible materials.
- Equipment **MUST** be level both front to back and side to side.
- Position the equipment so it will not tip or slide.
- Front casters **MUST** be locked once positioned.
- Recommended air temperature is 50° - 100°F (10° - 38°C).
- Proper air supply for ventilation is **REQUIRED AND CRITICAL** for safe and efficient operation.
- Do not obstruct the flow of ventilation air. Make sure the air vents of the equipment are not blocked.
- Do not install the equipment directly over a drain. Steam rising up out of the drain will adversely affect operation, air circulation, and damage electrical / electronic components.

### Weight Of Equipment

Standard Model	Model with Export Option	Weight
<b>Refrigerated Work Table With Backsplash</b>		
18648BSTMP	18648BST-E	390lbs (177kg)
18660BSTMP	18660BST-E	435lbs (197kg)
18672BSTMP	18672BST-E	495lbs (225kg)
18691BSTMP	18691BST-E	535lbs (243kg)
18699BSTMP	18699BST-E	594lbs (269kg)
186114BSTMP	186114BST-E	685lbs (310kg)
<b>Refrigerated Work Table</b>		
18648BUCMP	18648BUC-E	390lbs (177kg)
18660BUCMP	18660BUC-E	435lbs (197kg)
18672BUCMP	18672BUC-E	495lbs (225kg)
18691BUCMP	18691BUC-E	535lbs (243kg)
18699BUCMP	18699BUC-E	594lbs (269kg)
186114BUCMP	186114BUC-E	685lbs (310kg)
<b>Refrigerated Pizza Prep Table With Raised Rail</b>		
18648PTBMP	18648PTB-E	520lbs (236kg)
18660PTBMP	18660PTB-E	575lbs (260kg)
18672PTBMP	18672PTB-E	635lbs (288kg)
18691PTBMP	18691PTB-E	770lbs (350kg)
18699PTBMP	18699PTB-E	805lbs (365kg)
186114PTBMP	186114PTB-E	927lbs (420kg)
<b>Refrigerated Pizza Prep Table With Raised Rail</b>		
18648PTBMP-SMT		520lbs (236kg)
18660PTBMP-SMT		575lbs (260kg)
18672PTBMP-SMT		635lbs (288kg)
18691PTBMP-SMT		770lbs (350kg)
18699PTBMP-SMT		805lbs (365kg)
186114PTBMP-SMT		927lbs (420kg)
<b>Refrigerated Pizza Prep Table With LiquiTec® Rail - R290</b>		
18648PTLP	-	520lbs (236kg)
18672PTLP	-	635lbs (288kg)
18699PTLP	-	805lbs (365kg)
<b>Refrigerated Pizza Prep Table With LiquiTec® Rail - R290</b>		
18648PTLP-SMT	-	520lbs (236kg)
18672PTLP-SMT	-	635lbs (288kg)
18699PTLP-SMT	-	805lbs (365kg)
<b>Refrigerated Pizza Prep Table With Dual LiquiTec® Rails - R290</b>		
18648PDLP	-	691lbs (313kg)
18672PDLP	-	873lbs (396kg)
<b>Refrigerated Pizza Prep Table With LiquiTec® Rail - R404a</b>		
18648PTLV	18648PTL-E	520lbs (236kg)
18672PTLV	18672PTL-E	635lbs (288kg)
18699PTLV	18699PTL-E	805lbs (365kg)
<b>Refrigerated Pizza Prep Table With Dual LiquiTec® Rails - R404a</b>		
18648PDLV	-	691lbs (313kg)
18672PDLV	-	873lbs (396kg)
<b>Refrigerated Countertop Prep Rail</b>		
CTP8146-NB	CTP8146-NB-E	121lbs (55kg)
CTP8160-NB	CTP8160-NB-E	158lbs (72kg)

### Clearance Requirements

**⚠ DANGER**

Minimum clearance requirements are the same for noncombustible locations as for combustible locations. The flooring under the appliance must be made of a noncombustible material.

**⚠ DANGER**

Risk of fire/shock. All minimum clearances must be maintained. Do not obstruct vents or openings.

<b>All Models Back / Sides</b>	1.00" (25mm)
<b>Rail Model Tops</b>	14.00" (36cm)
<b>Caster Model Bottoms</b>	6.00" (15cm)

- Keep the vents clean and free of obstruction.
- Casters or legs must be used and not removed.

### Dimensions

Model & Export Option	Length	Depth	Height
<b>Refrigerated Work Table With Backsplash</b>			
18648BSTMP	48.00" (122cm)	31.50" (80cm)	40.00" (102cm)
18648BST-E			
18660BSTMP	60.00" (152cm)		
18660BST-E			
18672BSTMP	72.00" (183cm)		
18672BST-E			
18691BSTMP	91.00" (231cm)		
18691BST-E			
18699BSTMP	99.00" (251cm)		
18699BST-E			
186114BSTMP	114.00" (290cm)		
186114BST-E			
<b>Refrigerated Work Table</b>			
18648BUCMP	48.00" (122cm)	31.50" (80cm)	36.00" (91cm)
18648BUC-E			
18660BUCMP	60.00" (152cm)		
18660BUC-E			
18672BUCMP	72.00" (183cm)		
18672BUC-E			
18691BUCMP	91.00" (231cm)		
18691BUC-E			
18699BUCMP	99.00" (251cm)		
18699BUC-E			
186114BUCMP	114.00" (290cm)		
186114BUC-E			

Refrigerated Pizza Prep Table With Raised Rail (-SMT)			
18648PTBMP (-SMT) 18648PTB-E	48.00" (122cm)	31.50" (80cm)	42.00" (107cm)
18660PTBMP (-SMT) 18660PTB-E	60.00" (152cm)		
18672PTBMP (-SMT) 18672PTB-E	72.00" (183cm)		
18691PTBMP (-SMT) 18691PTB-E	91.00" (231cm)		
18699PTBMP (-SMT) 18699PTB-E	99.00" (251cm)		
186114PTBMP (-SMT) 186114PTB-E	114.00" (290cm)		
Refrigerated Pizza Prep Table With LiquiTec® Rail - R290 (-SMT)			
18648PTLP (-SMT)	48.00" (122cm)	31.50" (80cm)	42.00" (107cm)
18672PTLP (-SMT)	72.00" (183cm)		
18699PTLP (-SMT)	99.00" (251cm)		
Refrigerated Pizza Prep Table With Dual LiquiTec® Rails - R290			
18648PDLP	48.00" (122cm)	31.50" (80cm)	42.00" (107cm)
18672PDLP	72.00" (183cm)		
Refrigerated Pizza Prep Table With LiquiTec® Rail - R404a			
18648PTLV 18648PTL-E	48.00" (122cm)	31.50" (80cm)	42.00" (107cm)
18672PTLV 18672PTL-E	72.00" (183cm)	Plus 6" (15cm)	
18699PTLV 18699PTL-E	99.00" (251cm)	Cutting Board	
Refrigerated Pizza Prep Table With Dual LiquiTec® Rails - R404a			
18648PDLV	48.00" (122cm)	31.50" (80cm)	53.67" (136cm)
18672PDLV	72.00" (183cm)		
Refrigerated Countertop Prep Rail			
CTP8146-NB CTP8146-NB-E	46.00" (117cm)	17.03" (43cm)	12.55" (32cm)
CTP8160-NB CTP8160-NB-E	60.00" (152cm)		

**Capacity**

Shelf Max Load	Door Size		
	19" (48cm)	27" (69cm)	32" (81cm)
	70lbs (32kg)	124lbs (56kg)	140lbs (64kg)

Model & Export Option	# of 1/3 Size Pans In Rail	# Of Doors			# Of Shelves	Shelf Area	Base Volume
		19" (48cm)	27" (69cm)	32" (81cm)			
Refrigerated Work Table With Backsplash							
18648BSTMP 18648BST-E	NA		1		1	3.95ft <sup>2</sup> (3670cm <sup>2</sup> )	9.36ft <sup>3</sup> (265L)
18660BSTMP 18660BST-E	NA	1	1		2	6.51ft <sup>2</sup> (6048cm <sup>2</sup> )	13.81ft <sup>3</sup> (391L)

18672BSTMP 18672BST-E	NA		2		2	7.90ft <sup>2</sup> (7339cm <sup>2</sup> )	16.52ft <sup>3</sup> (468L)
18691BSTMP 18691BST-E	NA	1	2		3	10.29ft <sup>2</sup> (9560cm <sup>2</sup> )	22.35ft <sup>3</sup> (633L)
18699BSTMP 18699BST-E	NA		3		3	11.85ft <sup>2</sup> (11009cm <sup>2</sup> )	25.07ft <sup>3</sup> (427L)
186114BSTMP 186114BST-E	NA			3	3	14.46ft <sup>2</sup> (13434cm <sup>2</sup> )	30.16ft <sup>3</sup> (854L)
<b>Refrigerated Work Table</b>							
18648BUCMP 18648BUC-E	NA		1		1	3.95ft <sup>2</sup> (3670cm <sup>2</sup> )	10.25ft <sup>3</sup> (290L)
18660BUCMP 18660BUC-E	NA	1	1		2	6.51ft <sup>2</sup> (6048cm <sup>2</sup> )	15.10ft <sup>3</sup> (428L)
18672BUCMP 18672BUC-E	NA		2		2	7.90ft <sup>2</sup> (7339cm <sup>2</sup> )	18.04ft <sup>3</sup> (511L)
18691BUCMP 18691BUC-E	NA	1	2		3	10.29ft <sup>2</sup> (9560cm <sup>2</sup> )	24.44ft <sup>3</sup> (692L)
18699BUCMP 18699BUC-E	NA		3		3	11.85ft <sup>2</sup> (11009cm <sup>2</sup> )	27.31ft <sup>3</sup> (773L)
186114BUCMP 186114BUC-E	NA			3	3	14.46ft <sup>2</sup> (13434cm <sup>2</sup> )	33.00ft <sup>3</sup> (934L)
<b>Model &amp; Export Option</b>	<b># of 1/3 Size Pans In Rail</b>	<b># Of Doors</b>			<b># Of Shelves</b>	<b>Shelf Area</b>	<b>Base Volume</b>
		<b>19" (48cm)</b>	<b>27" (69cm)</b>	<b>32" (81cm)</b>			
<b>Refrigerated Pizza Prep Table With Raised Rail (-SMT)</b>							
18648PTBMP (-SMT) 18648PTB-E	6		1		1	3.95ft <sup>2</sup> (3670cm <sup>2</sup> )	9.36ft <sup>3</sup> (265L)
18660PTBMP (-SMT) 18660PTB-E	7	1	1		2	6.51ft <sup>2</sup> (6048cm <sup>2</sup> )	13.81ft <sup>3</sup> (391L)
18672PTBMP (-SMT) 18672PTB-E	9		2		2	7.90ft <sup>2</sup> (7339cm <sup>2</sup> )	16.52ft <sup>3</sup> (468L)
18691PTBMP (-SMT) 18691PTB-E	11	1	2		3	10.29ft <sup>2</sup> (9560cm <sup>2</sup> )	22.35ft <sup>3</sup> (633L)
18699PTBMP (-SMT) 18699PTB-E	12		3		3	11.85ft <sup>2</sup> (11009cm <sup>2</sup> )	25.07ft <sup>3</sup> (427L)
186114PTBMP (-SMT) 186114PTB-E	14			3	3	14.46ft <sup>2</sup> (13434cm <sup>2</sup> )	30.16ft <sup>3</sup> (854L)
<b>Refrigerated Pizza Prep Table With LiquiTec® Rail - R290 (-SMT)</b>							
18648PTLP (-SMT)	6		1		1	3.95ft <sup>2</sup> (3670cm <sup>2</sup> )	9.36ft <sup>3</sup> (265L)
18672PTLP (-SMT)	9		2		2	7.90ft <sup>2</sup> (7339cm <sup>2</sup> )	16.52ft <sup>3</sup> (468L)
18699PTLP (-SMT)	12		3		3	11.85ft <sup>2</sup> (11009cm <sup>2</sup> )	25.07ft <sup>3</sup> (427L)
<b>Refrigerated Pizza Prep Table With Dual LiquiTec® Rails - R290</b>							
18648PDLP	12						
18672PDLP	18						
<b>Refrigerated Pizza Prep Table With LiquiTec® Rail - R404a</b>							
18648PTLV 18648PTL-E	6		1		1	3.95ft <sup>2</sup> (3670cm <sup>2</sup> )	9.36ft <sup>3</sup> (265L)
18672PTLV 18672PTL-E	9		2		2	7.90ft <sup>2</sup> (7339cm <sup>2</sup> )	16.52ft <sup>3</sup> (168L)
18699PTLV 18699PTL-E	12		3		3	11.85ft <sup>2</sup> (11009cm <sup>2</sup> )	25.07ft <sup>3</sup> (710L)
<b>Refrigerated Pizza Prep Table With Dual LiquiTec® Rails - R404a</b>							
18648PDLV	12		1		1	3.95ft <sup>2</sup> (3670cm <sup>2</sup> )	8.41ft <sup>3</sup> (238L)
18672PDLV	18		2		2	7.90ft <sup>2</sup> (7339cm <sup>2</sup> )	15.42ft <sup>3</sup> (437L)

Model & Export Option	# of 1/3 Size Pans In Rail	Adapter Bars
<b>Refrigerated Countertop Prep Rail</b>		
CTP8146-NB CTP8146-NB-E	4	5
CTP8160-NB CTP8160-NB-E	6	7

**Electrical Service**

**DANGER**

Check all wiring connections, including factory terminals, before operation. Connections can become loose during shipment and installation.

**Warning**

This appliance must be grounded and all field wiring must conform to all applicable local and national codes. Refer to rating plate for proper voltage. It is the responsibility of the end user to provide the disconnect means to satisfy the authority having jurisdiction.

**Ground Fault Circuit Interrupter**

Ground Fault Circuit Interrupter (GFCI/GFI) protection is a system that shuts down the electric circuit (opens it) when it senses an unexpected loss of power, presumably to ground. Welbilt does not recommend the use of GFCI/GFI circuit protection to energize our equipment. If code requires the use of a GFCI/GFI then you must follow the local code. The circuit must be dedicated, sized properly and there must be a panel GFCI/GFI breaker. We do not recommend the use of GFCI/GFI outlets to energize our equipment as they are known for more intermittent nuisance trips than panel breakers.

Model	Amps	H.P.	NEMA Plug	Voltage, Hertz, Phase
<b>Refrigerated Work Table With Backsplash</b>				
18648BSTMP	3.8	0.20	5-15P	115, 60, 1
18660BSTMP	3.8	0.20		
18672BSTMP	3.8	0.20		
18691BSTMP	3.8	0.20		
18699BSTMP	3.8	0.20		
186114BSTMP	5.3	0.25		
<b>Optional Export Refrigerated Work Table With Backsplash</b>				
18648BST-E	2.5	1/4	Varies Per Destination	230-240, 50, 1
18660BST-E	2.8	1/3		
18672BST-E	5.3	1/2		
18691BST-E	5.3	1/2		
18699BST-E	5.3	1/2		
186114BST-E	5.0	3/4		
<b>Refrigerated Work Table</b>				

- Plug units with R290 refrigerant into a receptacle that is a minimum of 14" (36cm) above the floor.
- All electrical work, including wire routing and grounding, must conform to local, state and national electrical codes.
- The equipment must be grounded.
- A separate fuse/circuit breaker must be provided for each unit.
- The maximum allowable voltage variation is ±10% of the rated voltage at equipment start-up (when the electrical load is highest).
- If optional electrical receptacles are mounted in the unit's backsplash, they must be wired independently from the existing unit wiring.
- Check all green ground screws, cables and wire connections to verify they are tight before start-up.

Model	Amps	H.P.	NEMA Plug	Voltage, Hertz, Phase
18648BUCMP	3.8	0.20	5-15P	115, 60, 1
18660BUCMP	3.8	0.20		
18672BUCMP	3.8	0.20		
18691BUCMP	3.8	0.20		
18699BUCMP	3.8	0.20		
186114BUCMP	5.3	0.25		
<b>Optional Export Refrigerated Work Table</b>				
18648BUC-E	2.5	1/4	Varies Per Destination	230-240, 50, 1
18660BUC-E	2.8	1/3		
18672BUC-E	5.3	1/2		
18691BUC-E	5.3	1/2		
18699BUC-E	5.3	1/2		
186114BUC-E	5.0	3/4		
<b>Refrigerated Pizza Prep Table With Raised Rail (-SMT)</b>				
18648PTBMP(-SMT)	3.1	0.20	5-15P	115, 60, 1
18660PTBMP(-SMT)	3.1	0.20		
18672PTBMP(-SMT)	4.5	.25		
18691PTBMP(-SMT)	6.5	(2) .20		
18699PTBMP(-SMT)	6.5	(2) .20		
186114PTBMP(-SMT)	6.5	(2) .20		
<b>Optional Export Refrigerated Pizza Prep Table With Raised Rail</b>				
18648PTB-E	2.5	1/4	Varies Per Destination	230-240, 50, 1
18660PTB-E	2.8	1/3		
18672PTB-E	5.3	1/2		
18691PTB-E	5.3	1/2		
18699PTB-E	5.3	1/2		
186114PTB-E	5.0	3/4		
<b>Refrigerated Pizza Prep Table With LiquiTec® Rail - R290 (-SMT)</b>				
18648PTLP(-SMT)	4.7	1/3	5-15P	115, 60, 1
18672PTLP(-SMT)	8.6	1/3, 1/5	5-20P	115, 60, 1

Model	Amps	H.P.	NEMA Plug	Voltage, Hertz, Phase
18699PTLP(-SMT)	8.6	1/3, 1/5	5-20P	115, 60, 1
<b>Refrigerated Pizza Prep Table With Dual LiquiTec® Rails - R290</b>				
18648PDLP	10.1	1/3, 1/5	5-20P	115, 60, 1
18672PDLP	12.7	1/3, 1/5	5-20P	115, 60, 1
<b>Refrigerated Pizza Prep Table With LiquiTec® Rail - R404a</b>				
18648PTLV	7.0	1/4	5-15P	115, 60, 1
18672PTLV	14.0	1/2	5-20P	115, 60, 1
18699PTLV	14.0	1/2	5-20P	115, 60, 1
<b>Refrigerated Pizza Prep Table With Dual LiquiTec® Rails - R404a</b>				
18648PDLV	10.1	1/5, 1/3	5-20P	115, 60, 1
18672PDLV	12.7	1/5, 1/2	5-20P	115, 60, 1
<b>Optional Export Refrigerated Pizza Prep Table With LiquiTec® Rail</b>				
18648PTL-E	2.5	1/4	Varies Per Destination	230-240, 50, 1
18672PTL-E				
18699PTL-E				
<b>Refrigerated Countertop Prep Rail</b>				
CTP8146-NB	3.7	1/5	5-15P	115, 60, 1
CTP8160-NB	3.7	1/5	5-15P	115, 60, 1
<b>Optional Export Refrigerated Countertop Prep Rail</b>				
CTP8146-NB-E	2.5	1/4	Varies Per Destination	230-240, 50, 1
CTP8160-NB-E				

**Notice**

These appliances will operate within the marked rated voltage range without adjustment.

**Notice**

This symbol indicates the location of the equipotential bonding conductor connection.



**Drain Connections**

Self-contained work tables come standard with a condensate evaporator. If the condensate evaporator fails, the unit’s drain must have an outlet to an appropriate drainage area or container.

If the optional drain is ordered, a refrigerated rail can have a 1” (25mm) drain. The drain will be stubbed to the bottom of the machine compartment. Either run drain to a floor drain or add a valve to the base of the machine compartment and drain the rail to a container.

**⚠ Warning**

Moisture collecting from improper drainage can create a slippery surface on the floor and a hazard to employees. It is the owner’s responsibility to provide a container or outlet for drainage.

**Leg & Caster Installation**

**⚠ DANGER**

Legs or casters must be installed and the legs or casters must be screwed in completely to prevent bending. When casters are installed the mass of this unit will allow it to move uncontrolled on an inclined surface. These units must be tethered/secured to comply with all applicable codes.

**⚠ Warning**

The unit must be installed in a stable condition with the front wheels locked. Locking the front casters after installation is the owner’s and operator’s responsibility.

**Leveling**

After the cabinet has been placed in the desired location, cabinets with legs must be leveled. Level units from front to back and from side to side. Leveling will insure proper door operation and removal of condensate. Cabinets with casters must have the caster brake set so the cabinet cannot move.

**Stabilizing**

It is very important that all legs are properly adjusted to keep the cabinet level, evenly distribute the weight and to make sure the unit will not rock, lean or be unstable.

**Refrigeration**

Model	BTU System Capacity		Heat of Rejection		Charge
	Base	Rail	Base	Rail	
<b>Refrigerated Work Table With Backsplash</b>					<b>R290</b>
18648BSTMP	1550	NA	384	NA	150g
18660BSTMP	1550	NA	456	NA	150g
18672BSTMP	1550	NA	501	NA	150g
18691BSTMP	2440	NA	726	NA	150g
18699BSTMP	2440	NA	771	NA	150g
186114BSTMP	2936	NA	854	NA	150g
<b>Optional Export Refrigerated Work Table With Backsplash</b>					<b>R404A</b>
18648BST-E	475	NA	1462	NA	454g
18660BST-E	686	NA	1462	NA	680g
18672BST-E	856	NA	2261	NA	1134g
18691BST-E	1169	NA	2261	NA	1134g
18699BST-E	1220	NA	2591	NA	1134g
186114BST-E	1373	NA	2591	NA	1361g
<b>Refrigerated Work Table</b>					<b>R290</b>
18648BUCMP	1550	NA	384	NA	150g
18660BUCMP	1550	NA	456	NA	150g
18672BUCMP	1550	NA	501	NA	150g
18691BUCMP	2440	NA	726	NA	150g
18699BUCMP	2440	NA	771	NA	150g
186114BUCMP	2936	NA	854	NA	150g
<b>Optional Export Refrigerated Work Table</b>					<b>R404A</b>
18648BUC-E	475	NA	1462	NA	454g
18660BUC-E	686	NA	1462	NA	680g
18672BUC-E	856	NA	2261	NA	1134g
18691BUC-E	1169	NA	2261	NA	1134g
18699BUC-E	1220	NA	2591	NA	1134g
186114BUC-E	1373	NA	2591	NA	1361g
<b>Refrigerated Pizza Prep Table With Raised Rail</b>					<b>R290</b>
18648PTBMP	2128	1037	356	253	150g
18660PTBMP	2128	1230	421	354	150g
18672PTBMP	1648	1158	367	476	(2) 150g
18691PTBMP	1705	1199	531	608	(2) 150g
18699PTBMP	1922	1336	561	658	(2) 150g
186114PTBMP	1922	1405	616	750	(2) 150g
<b>Optional Export Refrigerated Pizza Prep Table With Raised Rail</b>					<b>R404A</b>
18648PTB-E	470	441	2001	952	454g
18660PTB-E	694	617	2409	1208	680g
18672PTB-E	776	794	2967	1587	1134g
18691PTB-E	1062	1058	3537	1865	1134g
18699PTB-E	1144	1147	3537	1945	1134g
186114PTB-E	1297	1323	5169	2433	1361g
<b>Refrigerated Pizza Prep Table With LiquiTec® Rail</b>					<b>R290</b>
18648PTLP	2708	1300	217	236	150g
18672PTLP	1733	1672	259	353	2@150g
18699PTLP	2007	1962	437	471	2@150g
<b>Refrigerated Pizza Prep Table With Dual LiquiTec® Rails</b>					<b>R290</b>
18648PDLP	2610	*1252/907	333	182/304	2@150g
18672PDLP	2610	*1610/1121	488	273/456	2@150g
<b>Refrigerated Pizza Prep Table With LiquiTec® Rail</b>					<b>R404A</b>
18648PTLV	2220	1132	293	529	16oz
18672PTLV	3455	2021	396	794	32oz
18699PTLV	4456	2433	598	1058	32oz

\*lower/upper rail

Model	BTU System Capacity		Heat of Rejection		Charge
	Base	Rail	Base	Rail	
<b>Refrigerated Pizza Prep Table With Dual LiquiTec® Rails</b>					<b>R404A</b>
18648PDLV	1453	1778	272	1058	16oz & 24oz
18672PDLV	1453	2876	359	1587	16oz & 32oz
<b>Optional Export Refrigerated Pizza Prep Table With LiquiTec® Rail</b>					<b>R404A</b>
18648PTL-E	470	441	2001	952	454g
18672PTL-E	776	794	2967	1587	1134g
18699PTL-E	1144	1147	3537	1945	1134g
<b>Refrigerated Countertop Prep Rail</b>					<b>R404A</b>
CTP8146-NB	NA	523	NA	305	6 oz.
CTP8160-NB	NA	653	NA	462	7.1 oz
<b>Optional Export Refrigerated Countertop Prep Rail</b>					<b>R404A</b>
CTP8146-NB-E	NA	305	NA	523	454g
CTP8160-NB-E	NA	462	NA	653	454g

### 18600PTB Cutting Board Installation

1. Orient each bracket with a bend at the back and the other to the outside.

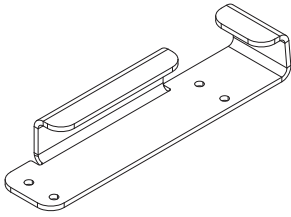

2. Place each bracket back against the rail and flush against the outside edge.

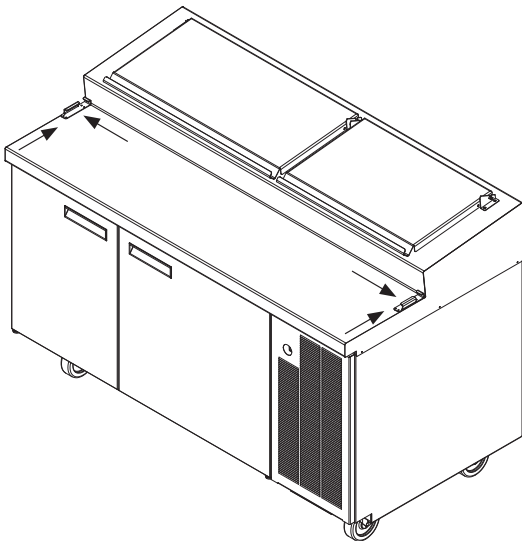
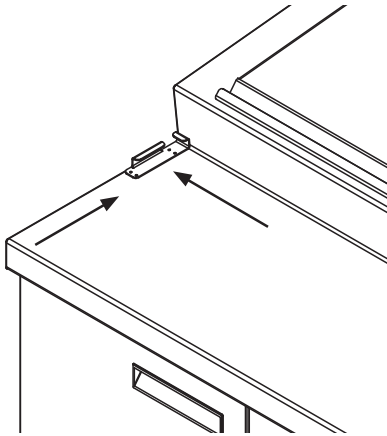

3. Mark the bracket hole locations.
4. Drill each 0.125" hole.
5. Secure each bracket to the Pizza Table with four 0.125" pop rivets.
6. Slide the cutting board into the brackets.

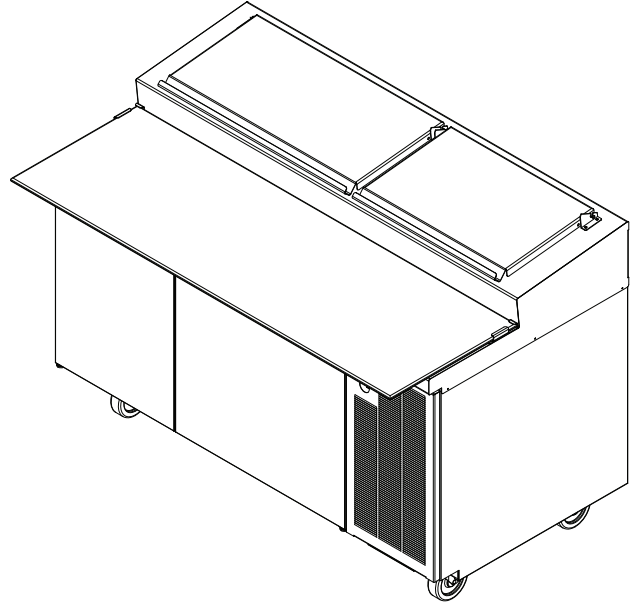

## Section 3 Operation

### DANGER

The on-site supervisor is responsible for ensuring that operators are made aware of the inherent dangers of operating this equipment.

### DANGER

Do not operate any appliance with a damaged cord or plug. All repairs must be performed by a qualified service company.

### DANGER

Never stand on the unit! They are not designed to hold the weight of an adult, and may collapse or tip if misused in this manner.

### DANGER

Keep power cord AWAY from HEATED surfaces. DO NOT immerse power cord in water. DO NOT let power cord hang over edge of table or counter.

### Warning

Do not contact moving parts.

### Warning

The operator of this equipment is solely responsible for ensuring safe holding temperature levels for all food items. Failure to do so could result in unsafe food products for customers.

### Warning

All covers and access panels must be in place and properly secured, before operating this equipment.

### Warning

Do not block the supply and return air grills or the air space around the air grills. Keep plastic wrappings, paper, labels, etc. from being airborne and lodging in the grills. Failure to keep the air grills clear will result in unsatisfactory operation of the system.

### Warning

Damp or wet hands may stick to cold surfaces.

### Caution

Overloading the storage area, restricting the air flow, and continuous opening and closing of the doors and drawers will hamper the units ability to maintain operational temperature.

### Caution

Do not throw items into the display case or storage area. Failure to heed this recommendation could result in damage to the interior of the cabinet or to the blower coil.

### CTP-NB Series, Countertop Prep Rail

#### 115V & 230-240V

The unit is equipped with one On/Off switch located on the right end of the unit. The unit's compressor will begin operating when this switch is turned to the On position. Temperature ranges for the rail are 33°F to 41°F (1°C to 5°C).

A minimum of one hour of off time per day with the pans removed from the rail is required to properly defrost the rail.

#### Refrigerated Work Tables

Delfield refrigerated bases are designed to maintain an operational temperature of 36°F to 40°F (2°C to 4°C). Self-contained units with a cord and plug have an ON/OFF switch located directly behind the louvered panel covering the compressor section. Simply turn the switch to ON to begin operation.

#### REFRIGERATED RAILS

Temperature in the refrigerated rail is designed to maintain 33°F to 41°F (0°C to 5°C). An ON/OFF switch is also provided for the rail; it shuts off the rail only.

Product in the rail should be moved to the refrigerated base at the end of the day. This allows you to turn the rail off at night to save energy and time to defrost as needed. It also helps maintain product quality. A minimum of one hour of off time per day with the pans removed from the rail is required to properly defrost the rail.

These units are not designed to cool warm food products. Items should be placed in the unit cooled at least to the desired holding temperature, if not slightly colder. Fill pan to 2.0" (5cm) below top of cold pan. In some applications, a gradual warming of product may occur, particularly at the exposed top of the products. Stirring or rotation of the product is necessary to maintain overall temperature.

Warming of food product can occur very quickly outside of the unit. When loading or rotating the product, avoid leaving food items in a non-refrigerated location for any length of time to prevent warming or spoilage. To ensure product quality product must be rotated every four hours. Always place covers on pans when not serving to maintain temperatures.

Air from air vents can affect the temperature in the cold pans. Add deflectors to vents to redirect airflow.

### Work Table Evaporator Fan Operation

When the refrigerator is initially powered up or immediately following a power outage the unit will begin cooling after a 3-6 minute delay. During normal operation the evaporator fan pulses independently of the compressor as dictated by the controller as follows:

1. During the cooling mode, compressor and evaporator fan run simultaneously.
2. During the compressor off mode, evaporator fan pulses three minutes on and three minutes off.
3. During an actual defrost event other than the off-cycle defrost, compressor stays off but the evaporator fan runs continuously.

Cooling Cycle		Defrost Cycle
Compressor On	Compressor Off	Compressor Off
Evaporator Fan On	Evap Fan Cycles On 3-Min, Off 3-Min	Evaporator Fan On

#### PTLV Pressure Control

Refrigerated pizza prep tables with LiquiTec® rails have a high pressure limiting device. Under severe overloading conditions, or in the event of a condenser fan failure or a plugged or blocked condenser, this device may shut down the refrigeration system. This device will automatically reset, but determining the cause of the high pressure condition should be investigated by a qualified refrigeration technician.

**⚠ Caution**

In attempting to adjust the pressure control, you can do damage to your unit. Please contact KitchenCare +1 (844) 724-2273 or your local service agent. Delfield is not responsible for charges incurred while having the pressure control adjusted.

Factory Recommended Settings	
Cut-in	20#
Cut-out	5#
Differential	15#

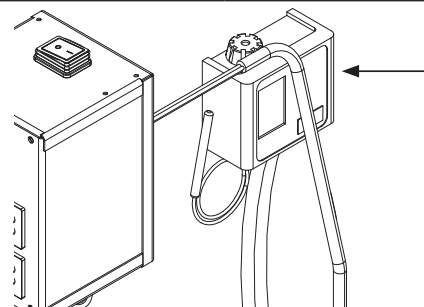

**PTLV Pressure Control**

**115Volt Work Table Control Assemblies**

- Controls are located in the mechanical section behind a louvered panel.
- The rail power switch is accessible through a hole in the louvered panel.

**Notice**

Rail temperature displayed is for refrigeration set point purposes only. Display does not reflect air or product temps in unit.

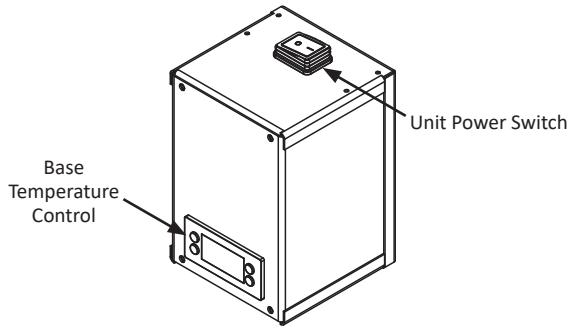

**Control Assembly For BSTMP Series & BUCMP Series, Work Table With Or W/o Backsplash**

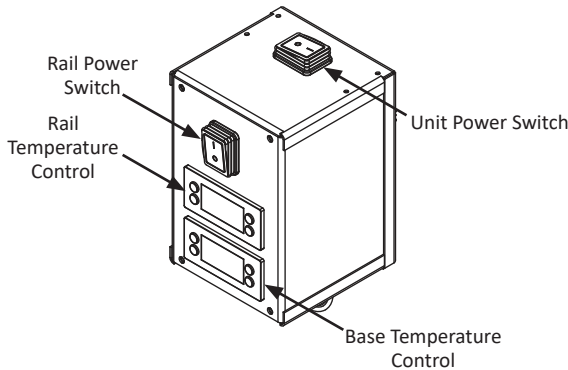

**Control Assembly For PTBMP Series & PTLV Series, Refrigerated Pizza Prep Table With Raised or LiquiTec® Rail**

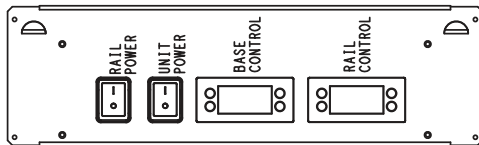

**Control Assembly For PDLV Series, Refrigerated Pizza Prep Table With Dual LiquiTec® Rails**

**AT START UP**

1. At initial start-up or anytime power is disconnected, then reconnected to the unit, the control will go into defrost mode.
2. The control will enter a DEFROST mode and the display will read dEF. The compressor and condenser fan as well as the evaporator fan will remain off until this initial defrost is complete. This initial defrost cycle may take up to 35 minutes to complete.
3. The display will continue to read dEF for an additional 10 minutes while the cooling cycle cools the box to the set temperature.
4. Then the digital thermostat will display box temperature.
5. The temperature control will cycle the compressor, evaporator fan motor and condenser fan motor to maintain box temperature at the control setting. For more information see Work Table Evaporator Fan Operation on page 16.

**Defrost**

The temperature control also monitors the evaporator temperature and will turn off the compressor and condenser fan motor when needed to allow accumulated frost on the evaporator to clear. During this defrost cycle, the digital temperature display will read dEF. After the defrost cycle is complete, the temperature control will return to a normal cooling cycle, but the display will continue to read dEF until the evaporator returns to normal cooling temperatures (up to 30 minutes).

The electronic temperature controller monitors evaporator temperature and compressor run time to determine the proper time for a positive defrost cycle. A defrost cycle can occur as often as every 60 minutes under extremely heavy usage. It can last a minimum of 2 minutes. When the controller enters the defrost mode the compressor is shut off and will remain off until the evaporator coil temperature exceeds 41°F (5°C) or the controller reaches a time limit of 75 minutes on a refrigerated unit.

**ERC112 TEMPERATURE CONTROL**

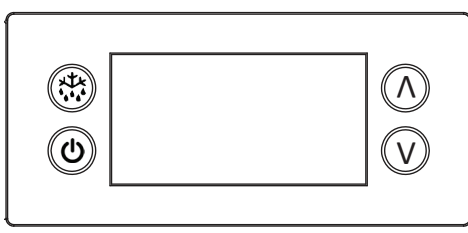

Operation / Indication			
Status	Displayed		Comments
Normal (°C)	Temp. [°C]		Unit depends on setting (parameters in control)
Normal (°F)	Temp. [°F]		
Show set-point	Temp.		
Set to Defrost	dEF / Temp		Depends on setting (parameters in control or as chosen by upper left button)
Sensor 1 defect	E01	X	Air sensor
Sensor 2 defect	E02	X	Coil sensor
Sensor 3 defect	E03	X	Open
Sensor 4 defect	E04	X	Open
High temperature alarm	Hi	X	Automatically switching at 2 sec rate
Low temperature alarm	Lo	X	
Line voltage too high, above 140 volts	uHi	X	
Line voltage too low, below 96 volts	uLi	X	
Control calls for cooling for more than 24 hours straight	LEA	X	Time includes defrost. Error will go away if the control cycles off the compressor or if the power is shut off. If error is on a cold pan it could be related to a high ambient temperature or not shutting the rail off nightly.

All alarms sound for approximately 10 seconds and then are silent for 50 seconds. It will do that for 15 cycles and then remain silent. The alarm code will still be present on the display until the fault clears.

**Press upper or lower right button.**

- Display show actual set-point (blinking).
  - If buttons untouched for 3 seconds returns to normal.
- Increase set-point by pressing upper button. Max value depends on parameters in control.
- Decrease set-point by pressing lower button. Min value depends on parameters in control.
  - If buttons untouched for 3 seconds returns to normal and stores new set-point.

**Press upper left button for 5 seconds.**

- Start defrost.

**Press lower left button for 5 seconds.**

- Unit goes into stand-by mode.
  - The display will read Off, then a period.
- Press the lower left button again for 5 seconds.
  - The display will read On.
  - The unit will then start up in the defrost mode, and display will read dEF.

**Temperature Alarm**

The alarm will sound and flash HI or LO 90 minutes after the unit has reached its alarm temperature point or after any power interruption if the temperature is above or below the alarm set points.

- The high refrigerator temperature point is 50°F (10°C).
- The low refrigerator temperature point is 25°F (-4°C).

**CHANGING DISPLAY FROM FAHRENHEIT TO CELSIUS ON ERC112 CONTROL**

1. Simultaneously hold the up and down arrows for 5 seconds to access menu for password protected parameters.



2. Screen should temporarily flash **PAS** and then move to a numeric screen.



3. Scroll to **187** using the up/down arrows and push the stand-by button (lower left button) to enter.



4. Scroll to **dis** using the up/down arrows and push the stand-by button (lower left button) to enter into the display menu.



5. Scroll to **CFu** using the up/down arrows and push the stand-by button (lower left button) to enter the display unit menu.



6. **-F** should be displayed indicating Fahrenheit. Use the down arrow to change it to **-C** for Celsius and hit the stand-by button (lower left button) to enter the change.



7. Push the defrost button (upper left button) to move out of the display unit menu.



8. Push the defrost button (upper left button) to move out of the display menu and back to the normal display.

NOTE: For steps 7 and 8, display will return back to normal display after 30 seconds of inactivity.



## 230-240Volt Export Work Table Controls

### EXPORT TEMPERATURE CONTROL

A thermostat controls temperature in the BUC-E, BST-E, PTB-E base, PTL-E base and rail. They are located in the machine compartment.

- The thermostat is set at the factory to provide proper operation at 2.5.
- To adjust the temperature, turn the knob clockwise as indicated on the control. Settings are from 1 through 9 (9 being the coldest).
- Adjustments should be made gradually.
- Several small adjustments will be more effective than one large adjustment.
- It may take an hour or longer to realize the temperature change depending on the application and location of the unit.

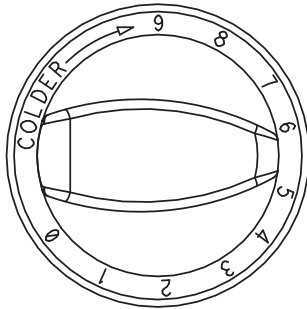

**Thermostat Dial**

### EXPORT 230-240 VOLT PRESSURE CONTROL

Temperature in the PTB-E rail is controlled by an adjustable pressure control located in the machine compartment and adjustable control has the word COLDER near the knob, with an arrow to indicate the adjustment direction. This control is field adjustable and does not require a service agent. If you have any questions, call an authorized service agent.

In attempting to adjust the pressure control, you can do damage to the unit by accidentally adjusting the differential.

NOTE: Delfield is not responsible for charges incurred while adjusting the pressure control.

Factory settings are:

- 25 psi (207 kPa) differential
- 55 psi (552 kPa) cut-in
- 30 psi (345 kPa) cut-out

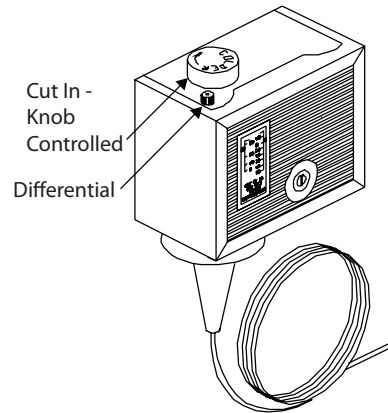

### PTB-E & PTL-E HIGH PRESSURE LIMITING DEVICE

All R404A models have a high pressure limiting device. Under severe overloading conditions, or in the event of a condenser fan failure or a plugged or blocked condenser, this device may shut down the refrigeration system. This device will automatically reset, but determining the cause of the high pressure condition should be investigated by a qualified refrigeration technician.

## Section 4 Maintenance

### ⚠ DANGER

It is the responsibility of the equipment owner to perform a Personal Protective Equipment Hazard Assessment to ensure adequate protection during maintenance procedures.

### ⚠ DANGER

Failure to disconnect the power at the main power supply disconnect could result in serious injury or death. The power switch DOES NOT disconnect all incoming power.

### ⚠ DANGER

Disconnect electric power at the main power disconnect for all equipment being serviced. Observe correct polarity of incoming line voltage. Incorrect polarity can lead to erratic operation.

### ⚠ Warning

When cleaning interior and exterior of unit, care should be taken to avoid the front power switch and the rear power cord. Keep water and/or cleaning solutions away from these parts.

### ⚠ Warning

Never use sharp objects or tools to remove ice or frost. Do not use mechanical devices or other means to accelerate the defrosting process.

### ⚠ Caution

Over shelves and other items mounted to the top of the counters should never be installed in the field due to the potential damage to the refrigeration system.

### ⚠ Caution

Maintenance and servicing work other than cleaning as described in this manual must be done by an authorized service personnel.

### General Cleaning

#### ⚠ Warning

When using cleaning fluids or chemicals, rubber gloves and eye protection (and/or face shield) must be worn.

#### Notice

Never use a high-pressure water jet for cleaning or hose down or flood interior or exterior of units with water. Do not use power cleaning equipment, steel wool, scrapers or wire brushes on stainless steel or painted surfaces.

You are responsible for maintaining the equipment in accordance with the instructions in this manual. Maintenance procedures are not covered by the warranty.

Maintenance	Daily	Weekly	Monthly	After Prolonged Shutdown	At Start-Up
Interior	X			X	X
Gasket	X			X	X
Exterior	X			X	X
Drain		X		X	X
Drawers/Door		X		X	X
Condenser Coil			X	X	X

## Interior Cleaning

The interior can be cleaned using soap and warm water. If this isn't sufficient, try ammonia and water or a nonabrasive liquid cleaner.

### GASKETS

Gaskets require regular cleaning to prevent mold and mildew build up and also to retain the elasticity of the gasket. Clean them with water and mild soap (not citrus based). Avoid full strength cleaning products on gaskets as this can cause them to become brittle and crack. Never use sharp tools or knives to scrape or clean the gasket. Gaskets can be easily replaced and do not require the use of tools or an authorized service person. The gaskets are dart style and can be pulled out of the groove in the door. Place gasket in warm water to make the material more pliable for installation. Dry and press into place.

### PREVENTING BLOWER COIL CORROSION

To help prevent corrosion of the blower coil, store all acidic items, such as pickles and tomatoes, in seal-able containers. Immediately wipe up all spills.

## Exterior Cleaning

### Notice

Never use an acid based cleaning solution on exterior panels! Many food products have an acidic content, which can deteriorate the finish. Be sure to clean the stainless steel surfaces of ALL food products.

Clean the area around the unit as often as necessary to maintain cleanliness and efficient operation.

Wipe surfaces with a damp cloth rinsed in water to remove dust and dirt from the outside of the unit. Always rub with the "grain" of the stainless steel to avoid marring the finish. If a greasy residue persists, use a damp cloth rinsed in a mild dish soap and water solution. Wipe dry with a clean, soft cloth.

Never use steel wool or abrasive pads for cleaning. Never use chlorinated, citrus based or abrasive cleaners.

Stainless steel exterior panels have a clear coating that is stain resistant and easy to clean. Products containing abrasives will damage the coating and scratch the panels. Daily cleaning may be followed by an application of stainless steel cleaner which will eliminate water spotting and fingerprints. Early signs of stainless steel breakdown are small pits and cracks. If this has begun, clean thoroughly and start to apply stainless steel cleaners in attempt to restore the steel.

Wipe casters with a damp cloth to prevent corrosion.

### DRAIN

Drains can become loose or disconnected during normal use. Be sure all drain lines are free of obstructions.

## Drawer Assembly Cleaning

The drawer assembly is designed to be cleaned easily. Both drawer and tracks are removable without tools. The drawer tracks are dishwasher safe or can be cleaned in a sink with detergents and a soft bristle brush. Drawers and tracks should be cleaned on a weekly basis.

### Remove Drawers

Pull the drawer box out until it stops. Lift up on the drawer front and pull the drawer box completely out. Using a soft bristle brush, clean the track on the bottom of the drawer box. When finished, it should be wiped clean of all food and debris.

### Tracks

The drawer box assembly must be removed. Pull the drawer tracks out until they hit a stop. Locate blue safety clips towards the back of each drawer track. Blue safety clips have a tab on the top. Push the tab back until it clicks. Lift up and pull the drawer tracks all the way out of the drawer cage.

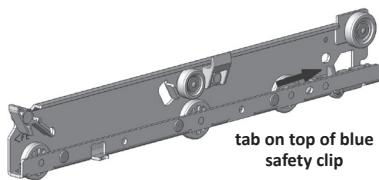

The drawer tracks are dishwasher safe or can be cleaned in a sink with detergents and a soft bristle brush. Drawers and tracks should be cleaned on a weekly

basis. Using a soft bristle brush, wash the track making sure each roller is thoroughly cleaned. The drawer cage should be cleaned with a soft bristle brush, removing any food and debris gathered on the bottom ledge. Once it's cleaned thoroughly with a soft bristle brush, wipe remaining debris clean with a soft towel.

### Reassembly

Push the drawer tracks into the drawer cage. The blue safety clip must remain pushed towards the back. Lift up and slide the drawer track all the way into the drawer cage. The blue safety clip will lock in place automatically. Once all tracks are replaced, insert the drawer box. Rest the drawer box bottom track on the front track roller. Then push the drawer back in place SLOWLY. When the drawer box is about half way in you will hit a STOP. You must lift the front of the drawer up approximately ½" (1.3cm) to continue inward. Clean tracks as often as possible. The cleaner the tracks are the better they will operate.

## Doors

Over time and with heavy-use doors, the hinges may become loose. If this happens, tighten the screws that mount the hinge brackets to the frame of the unit. Loose or sagging doors can cause the hinges to pull out of the frame, which may damage both the doors and the hinges. In some cases this may require qualified service agents or maintenance personnel to perform repairs.

## Cleaning The Condenser Coil

In order to maintain proper refrigeration performance, the condenser fins must be cleaned of dust, dirt and grease regularly. It is recommended that this be done monthly. If conditions are such that the condenser is totally blocked in a month, the frequency of cleaning should be increased. Clean the condenser with a vacuum cleaner or stiff brush. If extremely dirty, a commercially available condenser cleaner may be required.

Failure to maintain a clean condenser coil can initially cause high temperatures and excessive run times. Continuous operation with a dirty or clogged condenser coil can result in compressor failure. Neglecting the condenser coil cleaning procedures will void any warranties associated with the compressor and cost to replace the compressor.

## Section 5 Diagrams

---

### Smart Scale in Cheese Grate Assembly

with No Tablet

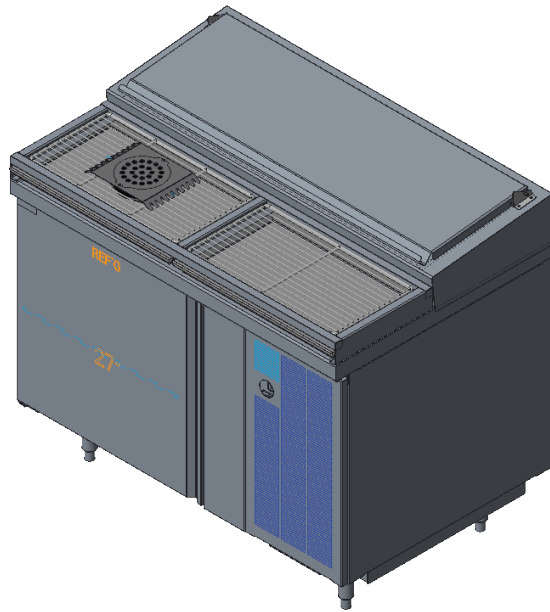

### Smart Scale in Cheese Grate Assembly

with EVO Tablet mounted to cover

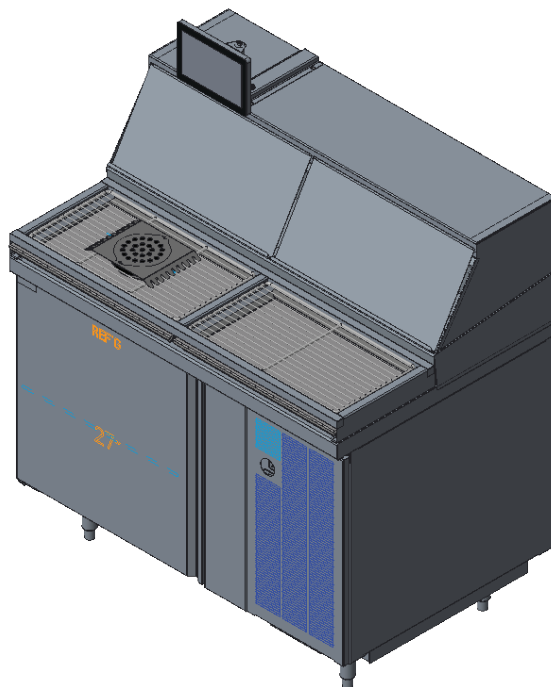

## Smart Scale in Cheese Grate Assembly

with EVO Tablet mounted to wall

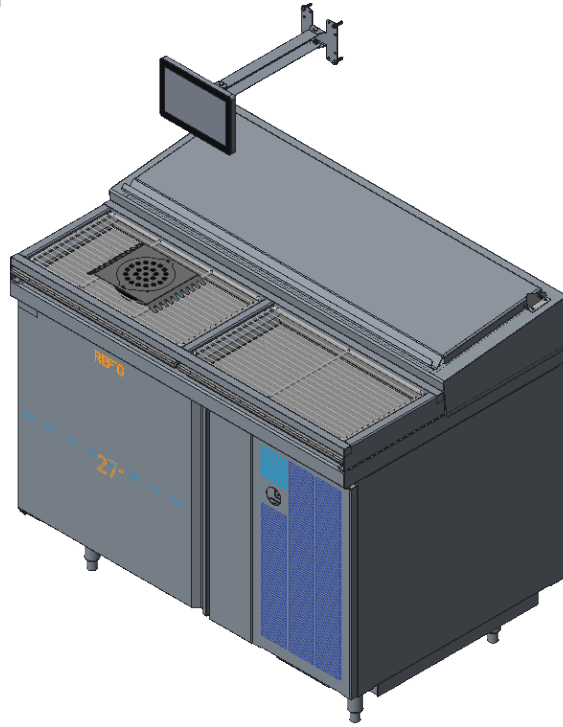

### Additional Notes:

- Scale and Tablet location can be positioned left or right on unit.
- Scale is battery operated...EVO table is powered by cord/plug.
- Receptacle for EVO tablet is to be customer supplied.

THIS PAGE INTENTIONALLY LEFT BLANK

THIS PAGE INTENTIONALLY LEFT BLANK

<b>Import:</b>  <b>Germany</b> <b>Welbilt Deutschland</b> Auf der Weih 11 35745 Herborn Germany +49 2772 58050	<b>Import:</b>  <b>United Kingdom</b> <b>Welbilt UK Limited</b> Provincial Park, Nether Lane Ecclesfield Sheffield, S35 9ZX United Kingdom +44 1483 464900
---	--



Welbilt offers fully-integrated kitchen systems and our products are backed by KitchenCare® aftermarket parts and service. Welbilt's portfolio of award-winning brands includes **Cleveland™**, **Convotherm®**, **Crem®**, **Delfield®**, **fitkitchen®**, **Frymaster®**, **Garland®**, **Kolpak®**, **Lincoln®**, **Manitowoc®**, **Merco®**, **Merrychef®** and **Multiplex®**.

*Bringing innovation to the table* • [welbilt.com](http://welbilt.com)