User Manual

Sally THE
ROBOT

October, 2019

User Manual v3

Address

Chowbotics
1502 Crocker Ave
Hayward, CA 94544

Contact

+1 (831) CHOWBOT
+1 (831) 246-9268

Online

Email : info@chowbotics.com
Website: www.chowbotics.com

CHOWBOTICS™





The Future of Fresh is Here...

We're pioneering a whole new industry in the most delicious way possible. With proprietary technology, our robots count calories, deliver precise portions, and serve up vibrant, forward-thinking food.

Our mission is to bring fresh food to places where it wouldn't otherwise exist.

Sally User Manual

Introduction	6
What's in this Manual	9
Hazard prevention	10
What's in the box:	12
Hardware Systems	14
Tablet Interface	30
Basic Use	33
Canister Assembly: Outer Canisters	34
Canister Assembly: Inner Canisters	36
Canister Assembly: Dressing Canister	38
Canister Loading Procedure: Mounting Points	42
Care & Cleaning	45
Daily Maintenance Tasks	46
Weekly Maintenance Task	52
Monthly Maintenance Tasks	57
Troubleshooting	63
Ingredient Not Dispensing	64
Ingredient is Dispensing too Much or too Little	65

Table of Contents

Loading Error Detected/ Loud Noise 66

App Crash/ Unresponsive 67

Machine Not Moving/ Unresponsive 68

Receipt Not Printed 69

Contact Us **71**



Introd





uction

SAFETY PRECAUTIONS



Rotating Parts Hazard

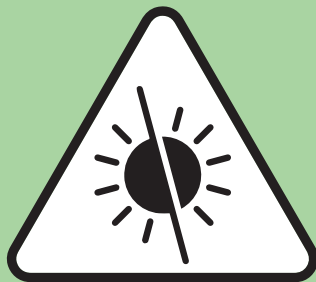

Avoid Direct Sunlight



Tipping Hazard



Risk of Fire

What's in this Manual

This manual describes the operating features of Sally the Salad Robot. The setup and operating procedures given in this manual are only applicable to model 2.0 sally machines.

Voidance of Warranty

Sally is approx. 800lbs and should only be lifted using appropriate machinery. Attempting to move Sally could result in personal injury or death. Two people are required when attempting to relocate the machine. Chowbotics will not be liable for injuries related to moving Sally. Damage caused by moving Sally could void the customer warranty. If you have questions on how to move Sally properly, **contact us at +1 (831) CHOWBOT (831- 246-9268).**

This list is not comprehensive of all actions that could void the warranty.

Where to Place Sally

When finding a suitable location for Sally there are a few considerations to take into account. Do not operate or store Sally outdoors. Sally should be kept in a dry area. Avoid direct sunlight. Avoid uneven surfaces. Sally must be positioned at least **8 inches** away from all surrounding walls, structures, or other equipment.

Icing Prevention

WARNING: POWER OFF THE MACHINE DURING CLEANING OR MAINTENANCE TO PREVENT ICE BUILD UP.

Ice build-up can occur if the door is left open while the machine is running or if the home canister cap is not in the lower position over dispensing chute for extended periods (up to 15 mins). Ice build up prevents the machine from running properly and can result in downtime of up to 24 hours to de-ice.

Moving Parts

Several moving components make up Sally's interior hardware system. To prevent injury, have the door panel closed when motors are moving. When opening Sally, be sure the carousel and motors have come to a complete stop before handling.

Hazard prevention

Do not tip Sally or lay sideways for any reason.

Do not allow unauthorized persons, such as minors or customers, to Restock Sally for any reason.

Do not reach into the dispensing chute from the dispensing bin for any reason. Do not use tools or foreign objects in the

dispensing chute for any reason.

If the power supply cord is damaged, it must be replaced by the manufacturer, its service agent or similarly qualified persons.

Electrical Requirements

Sally requires a dedicated 20A circuit at 120VAC. This means a circuit breaker that only Sally uses, with nothing else plugged into the circuit. Sally uses a Ground Fault Circuit Interrupter (GFCI) which detects electrical defects and immediately trips if a current unbalance is present or a leakage to Earth Ground is detected. This means that Sally requires a three-pin NEMA 5-15R receptacle, with Line, Neutral, and Earth Ground present and correctly wired in Compliance with the US National Electric Code (NEC). Any electrical contractor will be familiar with the requirements of both Federal and Local building and electrical codes. Installers are recommended to use a single receptacle per circuit, so that no other devices can be plugged in.



Child Safety Precautions

This appliance can be used by children aged from 8 years and above and persons with reduced physical, sensory or mental capabilities or lack of experience and knowledge if they have been given supervision or instruction concerning use of the appliance in a safe way and understand the hazards involved. Children shall not play with this appliance. Cleaning and user maintenance shall not be performed by children without supervision.

Important

Chowbotics reserves the right to change specifications and product design without notice. Such revisions do not entitle the buyer to corresponding changes, improvements, additions, or replacements for previously purchased equipment.

WARNING: Keep clear of surrounding walls, structures, or other equipment by at least **8 inches** to ensure proper ventilation.

WARNING: Keep ventilation openings, in the appliance enclosure or in the built-in structure, clear or obstruction.

WARNING: Do not use mechanical devices or other means to accelerate the defrosting process, other than those recommended by the manufacturer.

WARNING: Do not store explosive substances such as aerosol cans with a flammable propellant in this appliance.

Recognized as a Top Food Trend
The New York Times

Sally
THE ROBOT

Salads, bowls, & snacks



**Fresh,
Delicious
Meals**

POWERED BY CHOWBOTICS® Need help? 1.831.chowbot



FreshSeal
Airtight
technology
for maximum
freshness

Eat With Confidence

- Service
Daily
- Refrigerated
at a Cool 38°
- Airtight
for Freshness





What's in the box:

- Sally machine
- Sally stand
- Keys
- Welcome package
- Kitchen Accessories
- Spare hardware
- Receipt Printer (optional)
- Card Reader (optional)

Customizable

22 ingredient canisters that make over 1,000 refrigerated options for made-to-order meals.

Always Available

Offer fresh food 24/7.

Optional credit card terminal and payroll deduction.

Ease of Use

Simple to use, operate and maintain. Designed with transient workers in mind.

Keeps it Fresh

Extends shelf life and minimizes the risk of food-borne illness. Ingredients last longer and less power is utilized.

Cost Savings

Reduce food waste and labor costs while still allowing for customization.

Increases Productivity

Makes 8-component meals in seconds. Serves up to 100 meals before replacing component ingredients.

Complete Nutrition

Full nutritional information available for every dish including: Protein, Fiber, Fat, Carbs, and total Calories.

Sally 2.0 Specs

Sally THE ROBOT



Electrical Rating	20A Dedicated Service 120VAC, 20A, 60Hz NEMA 5-15R
Refrigeration System	Refrigerant: R134-a
Connectivity	Cellular (Ethernet and WiFi not recommended)
Required Operating Environment	Indoors, temperature controlled, out of direct sunlight
Tablet Display Size	15.6"
ChowboticsTV Screen	32" LED HD (720p)
Weight	750 lb
Dimensions with ChowboticsTV*	31 ³ / ₄ " W 41" D 90" H
Install Clearance with ChowboticsTV	8" for both sides & back, 24" for top
Dimensions Including Clearance	47 ³ / ₄ " W 49" D 114" H
Separate Ingredient Canisters	22
Total Combinations of Bowls	>1000
Number of Bowls Before Refilling	40 – 100**
Bowl Storage Capacity	70 bowls and lids
Casters	Swivel with brake

*Sally arrives without ChowboticsTV attached with dimensions of 31³/₄" W | 38" D | 73" H
 **Depends on ingredients, portion size, and bowl type



Shipping Dimensions

Crate with Sally 2.0 42" x 36" x 82", 822 lbs

Pallet with ChowboticsTV,
Spare Canisters, Accessories/
Spare Parts Kit, 500 Bowls & Lids 46" x 34" x 71", 275 lbs

Front

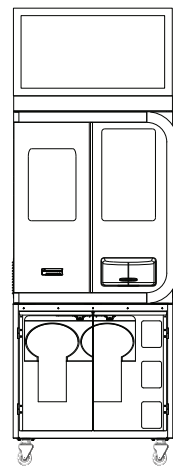

Side

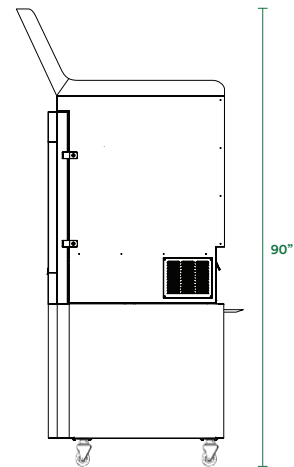

- 8" min clearance on all sides | Maximum height measurements
- We recommend an outlet cover to prevent your Sally from being unplugged

info@chowbotics.com +1 (650) 362-3700
 sales@chowbotics.com 1502 Crocker Ave, Hayward, CA 95455

CHOWBOTICS®
 by DOORDASH





Vendor Sabert
Dimensions 8.06"(Diameter) x 2.31"(Height)
Volume 32 oz
Item Number 49032D300
Usage Salads, Grain bowl, Pasta

Bowl [Order Here](#)
Lid [Order Here](#)

Vendor Harvest Pack
Dimensions 8.14"(Diameter) x 2.44"(Height)
Volume 32 oz
SKU BGSB106-500
Usage Salads, Grain bowl, Pasta

[Order Bowls & Lids](#)



FRONT

1. Tablet Interface
2. Card Reader
3. Window
4. Door Panel Latches
5. Dispensing Area
6. Bowl Door

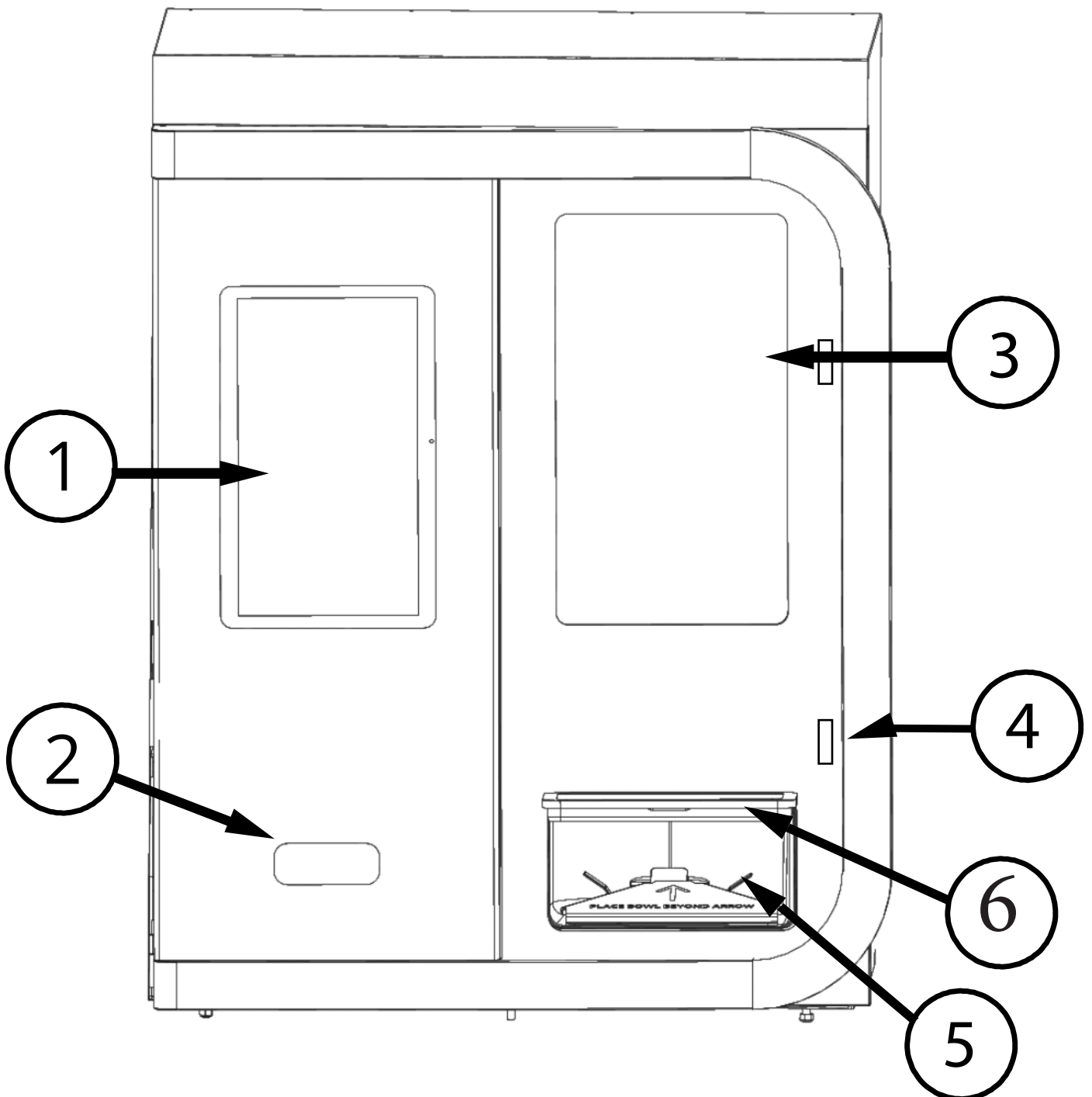

REAR

REAR PANEL

- 1. Temperature LCD
- 2. Power Switch

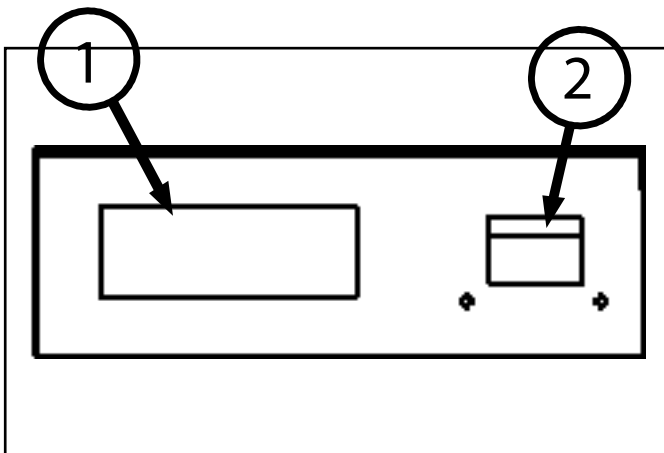
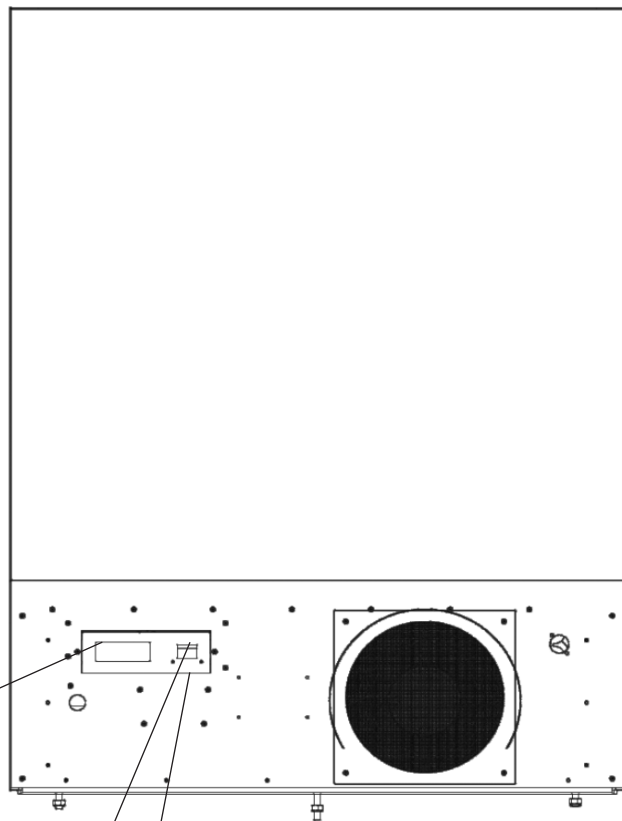

Exterior Layout

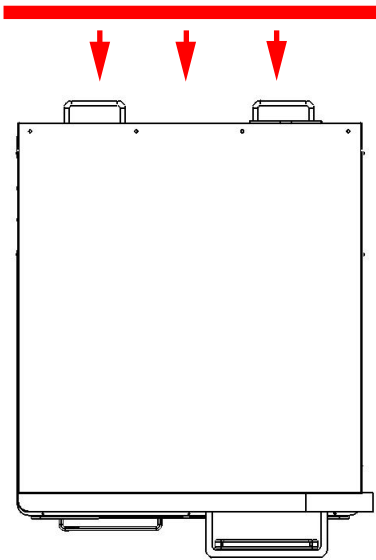

WARNING: Keep clear of surrounding walls, structures, and other equipment by at least **8 inches** to ensure proper ventilation.

Interior Layout

UPPER DECK

1. Canister Carousel
2. Dispensing Chute
3. Outer Motor
4. Inner Motor
5. Motor Arm
6. Interior Mat
7. Guide Rail

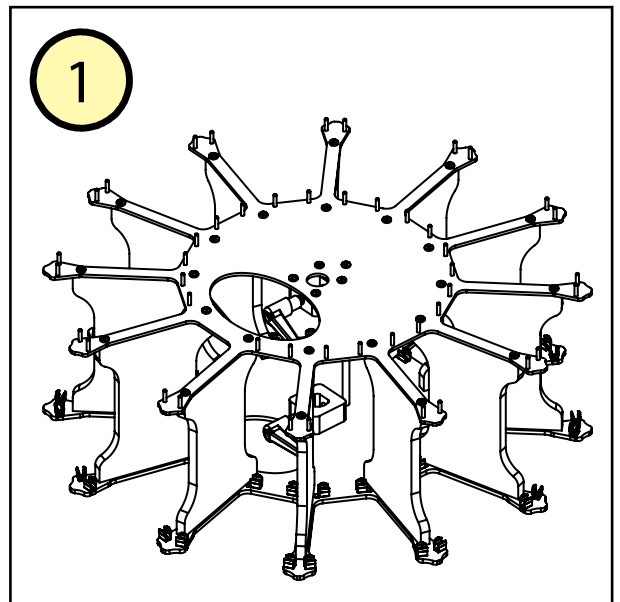

Introduction

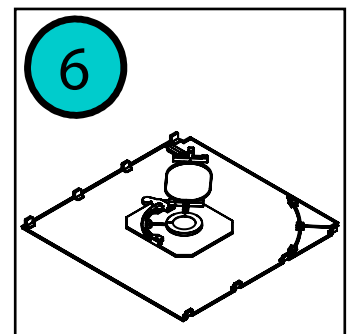
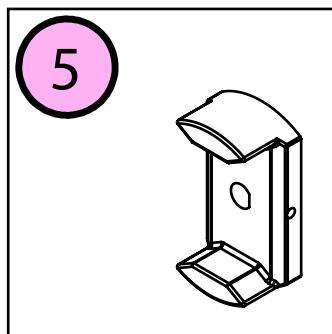
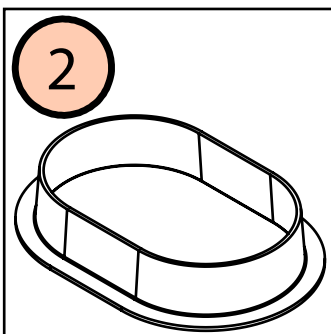
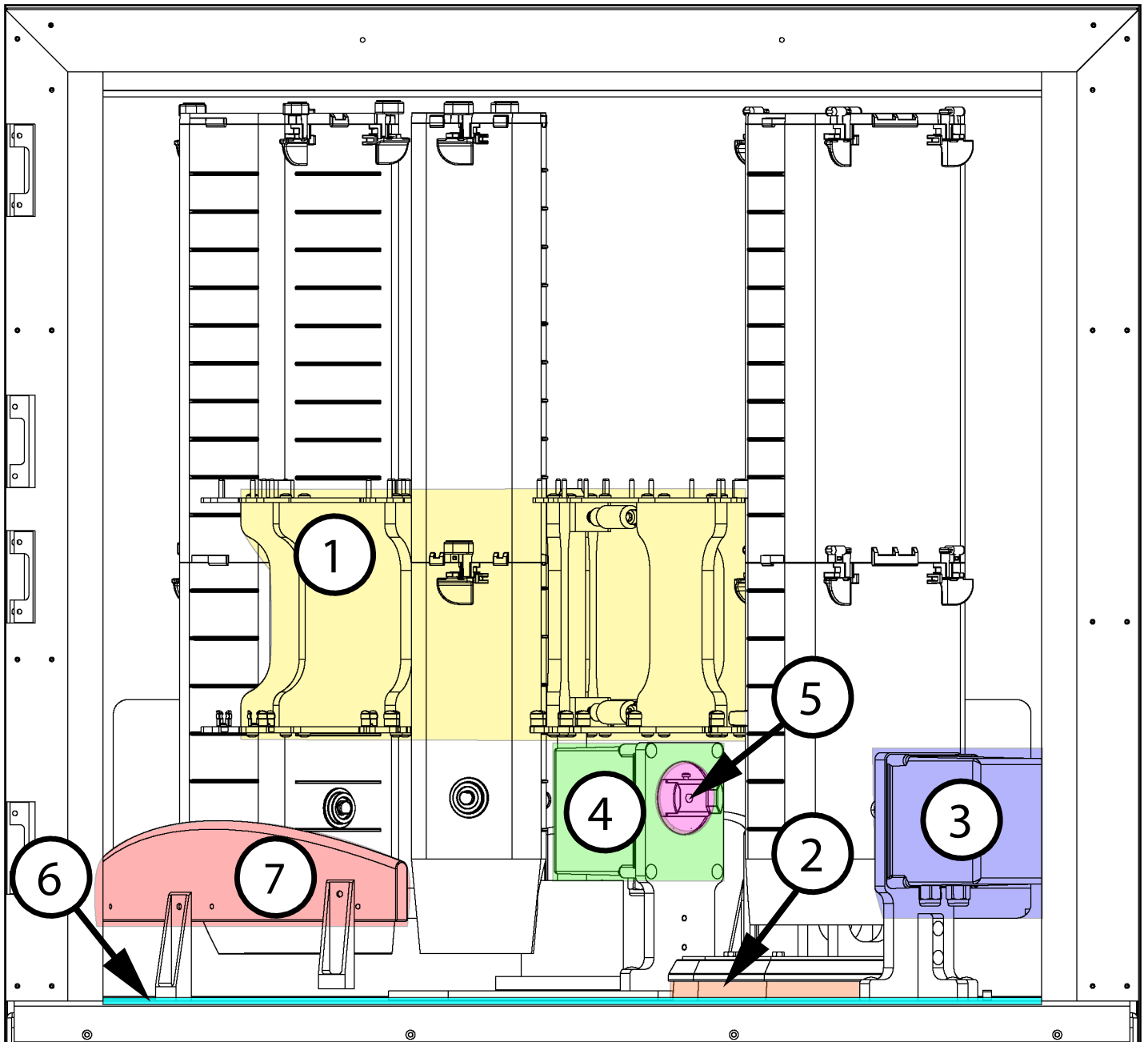

DOOR PANEL (INTERIOR)

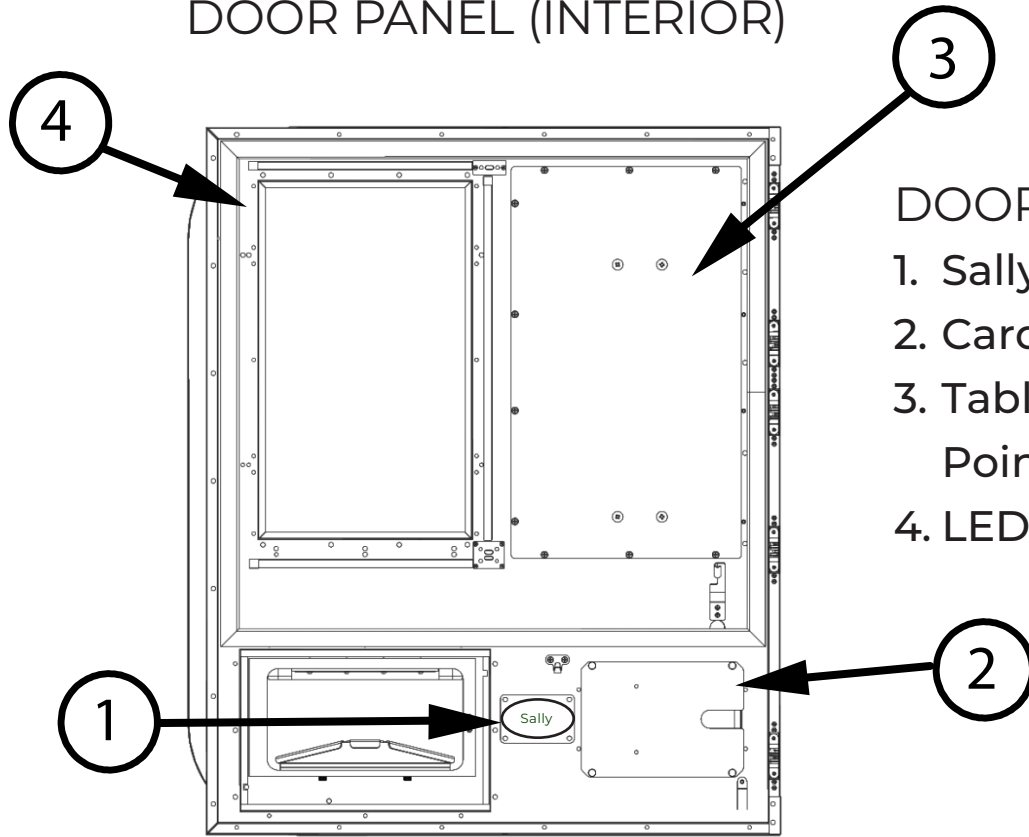

DOOR PANEL (INTERIOR)

1. Sally Number
2. Card Reader Access Point
3. Tablet Assembly Access Point
4. LED Strip Lighting

LOWER DECK

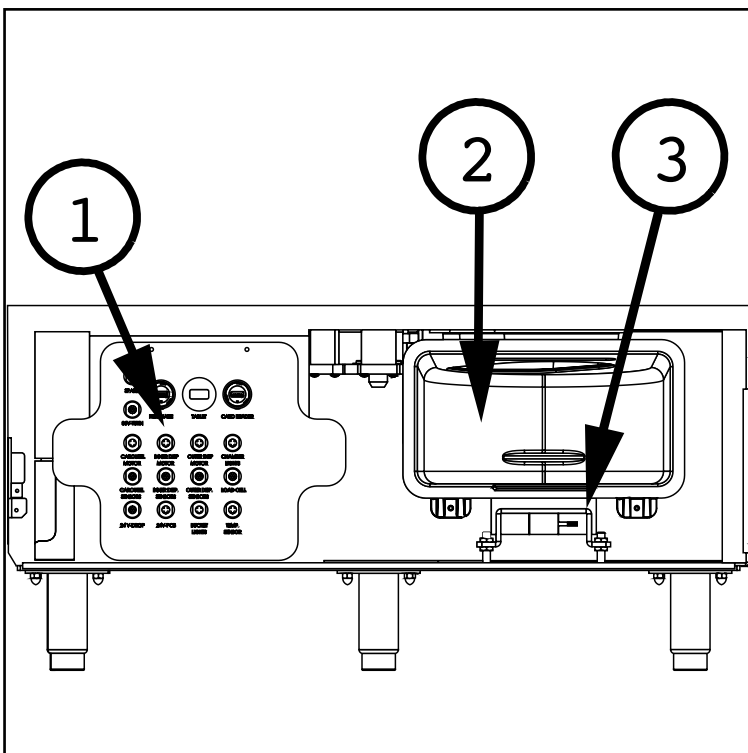

LOWER DECK

1. Control Panel
2. Bin (Dispensing Area)
3. Bin Plate

BIN (DISPENSING AREA)

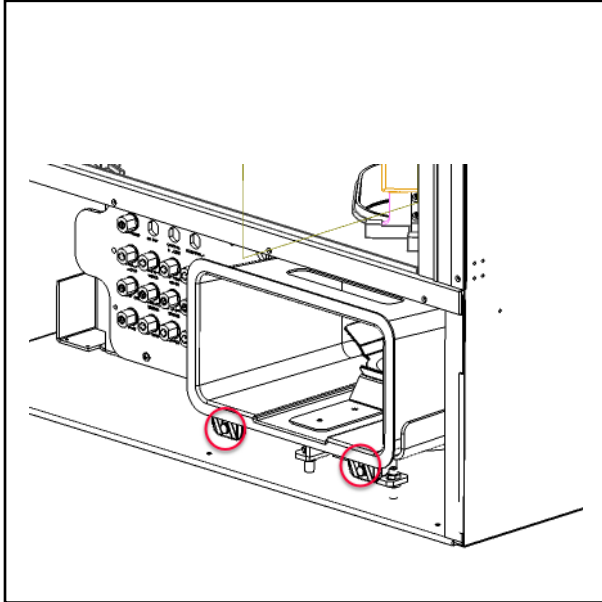

Interior Layout (Continued)

BIN ASSEMBLY

1. Bin Thumbscrews (highlighted circles above)
2. Bowl Flower Ramp

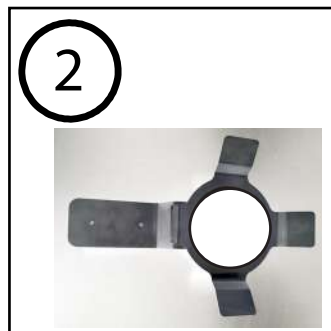
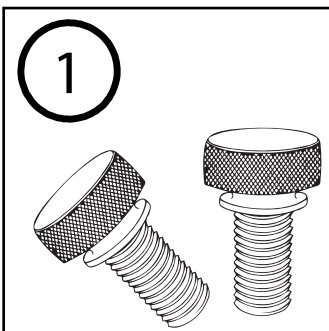

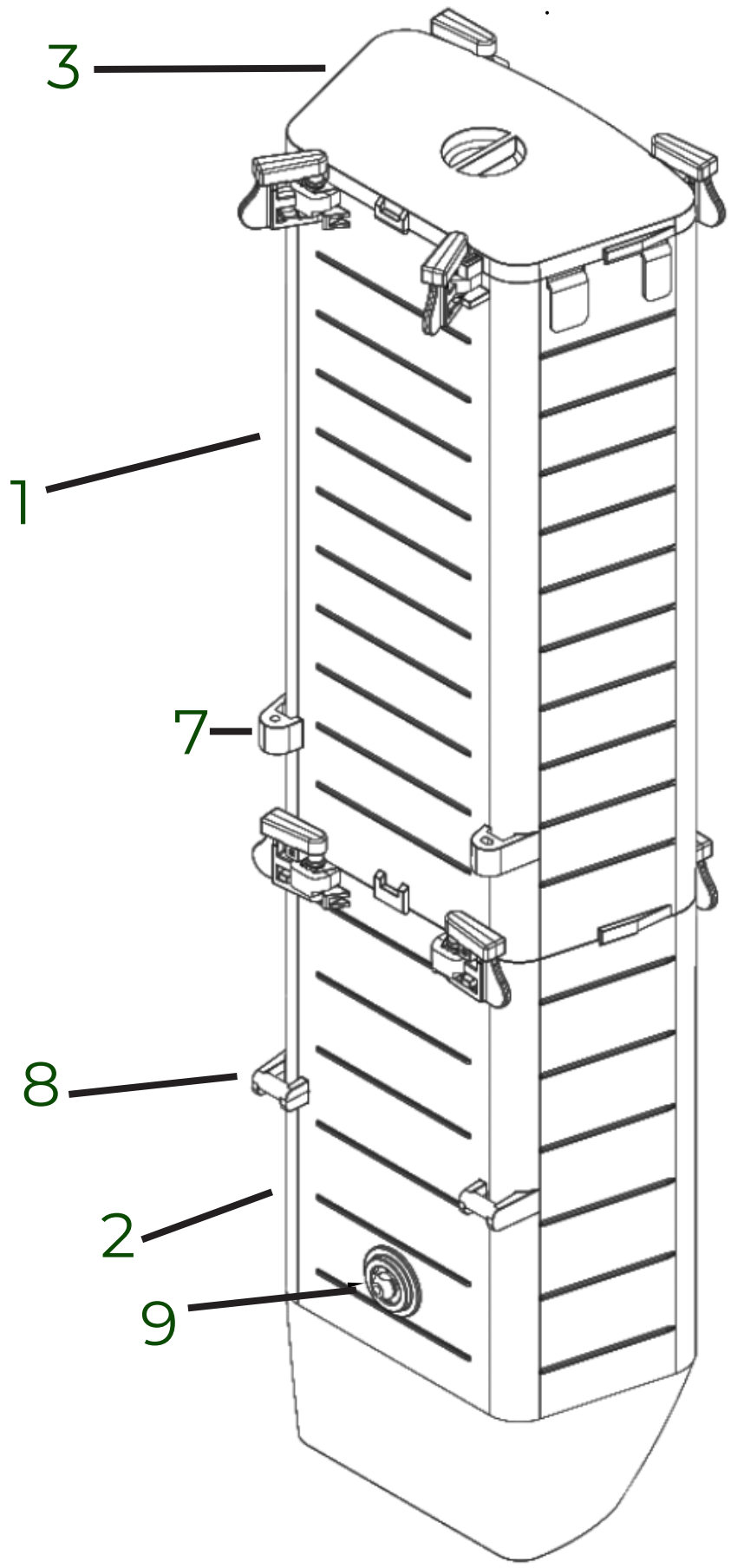

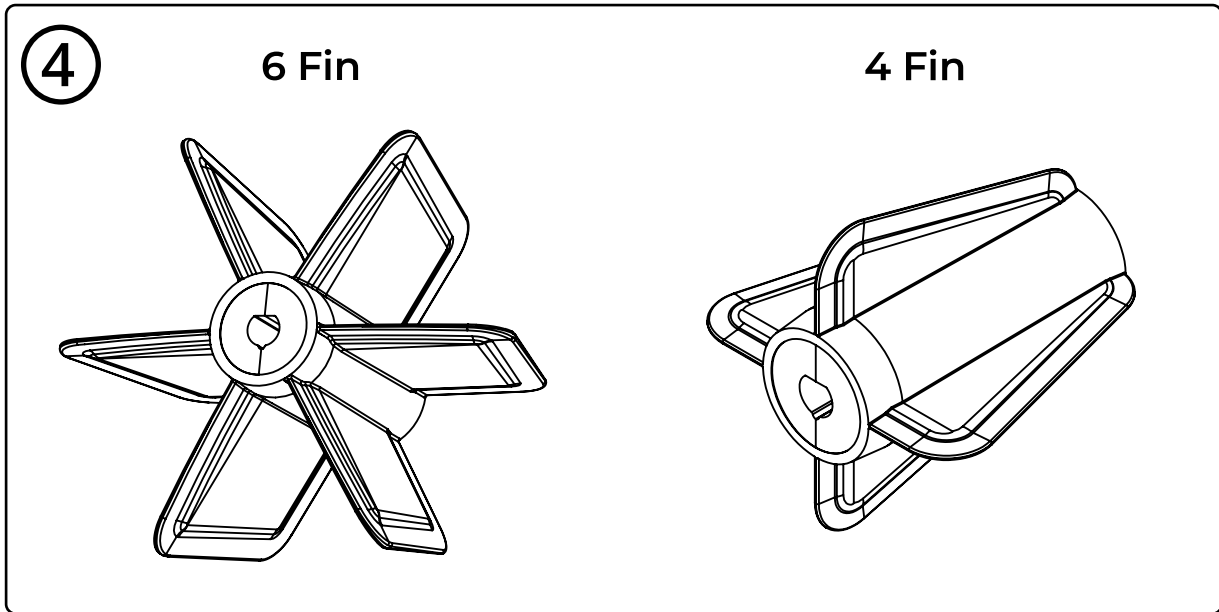

1. Top Half
2. Bottom Half
3. Lid
4. Paddle (Fin Counts)
5. Shaft Handle
6. Paddle Shaft
7. Pin Mounts
8. Clamp Mounts
9. Locking Mechanism

Outer & Inner Canister Layout

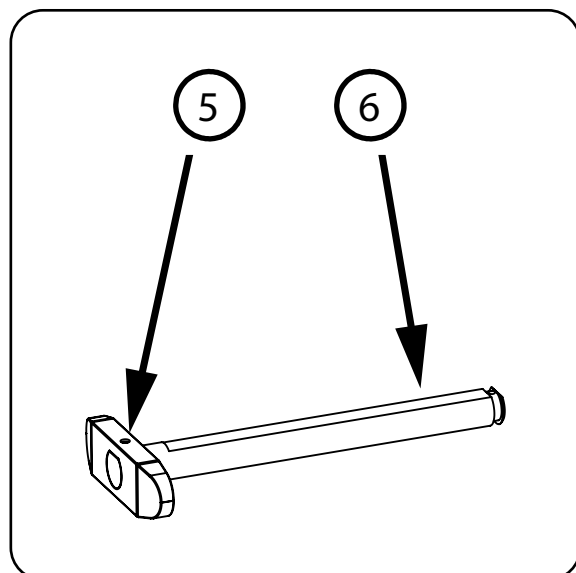

Dressing Canister Layout

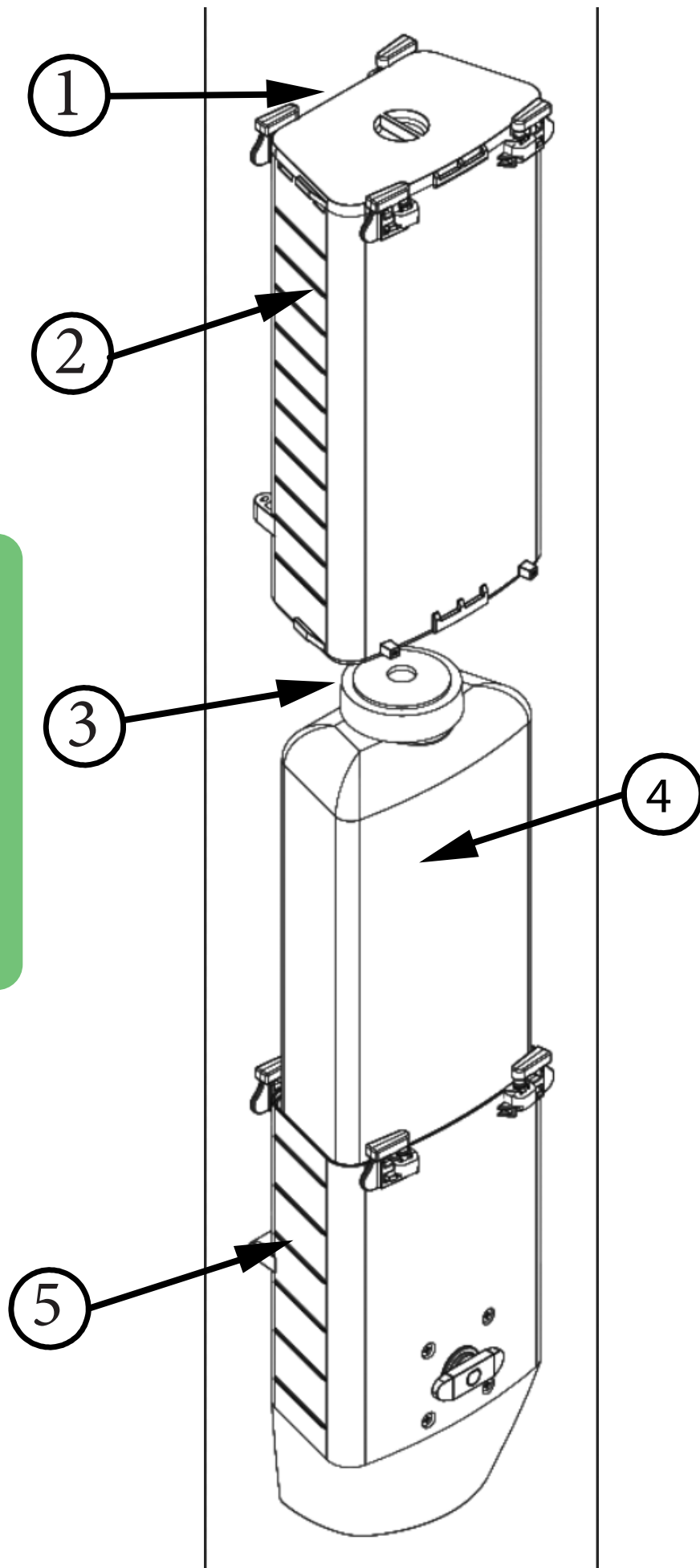

INTERNAL ASSEMBLY

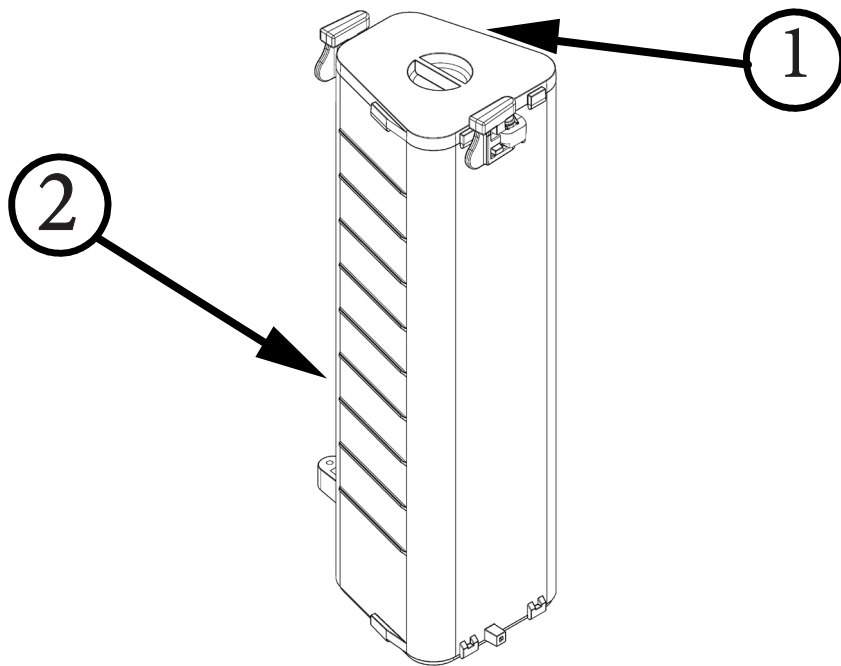

- 1. Lid
- 2. Top Half
- 3. Bottle Cap
- 4. Dressing Bottle
- 5. Bottom Half
- 6. Paddle Shaft
- 7. Pump Base
- 8. Clamp Release

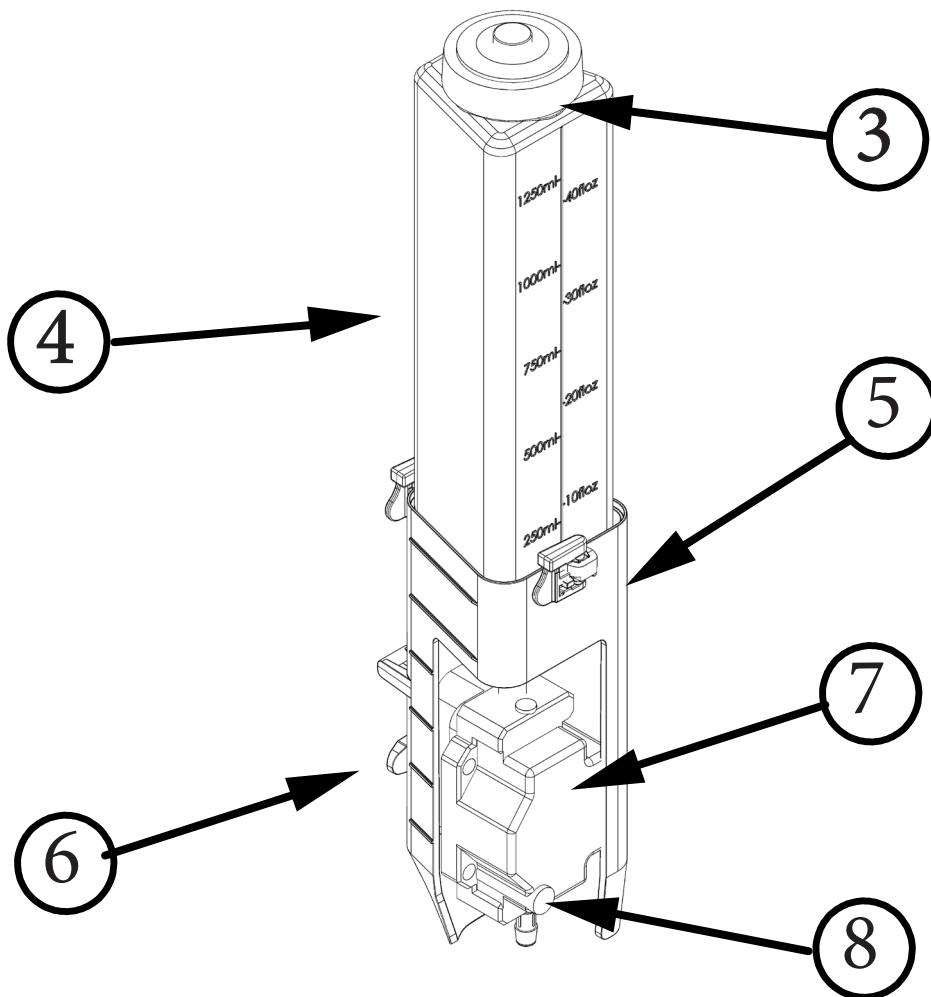

1. Top Half
2. Bottom Half
3. Lid
4. Rubber Insulation Foot
5. Raiser Mechanism (paddle shaft is built-in)

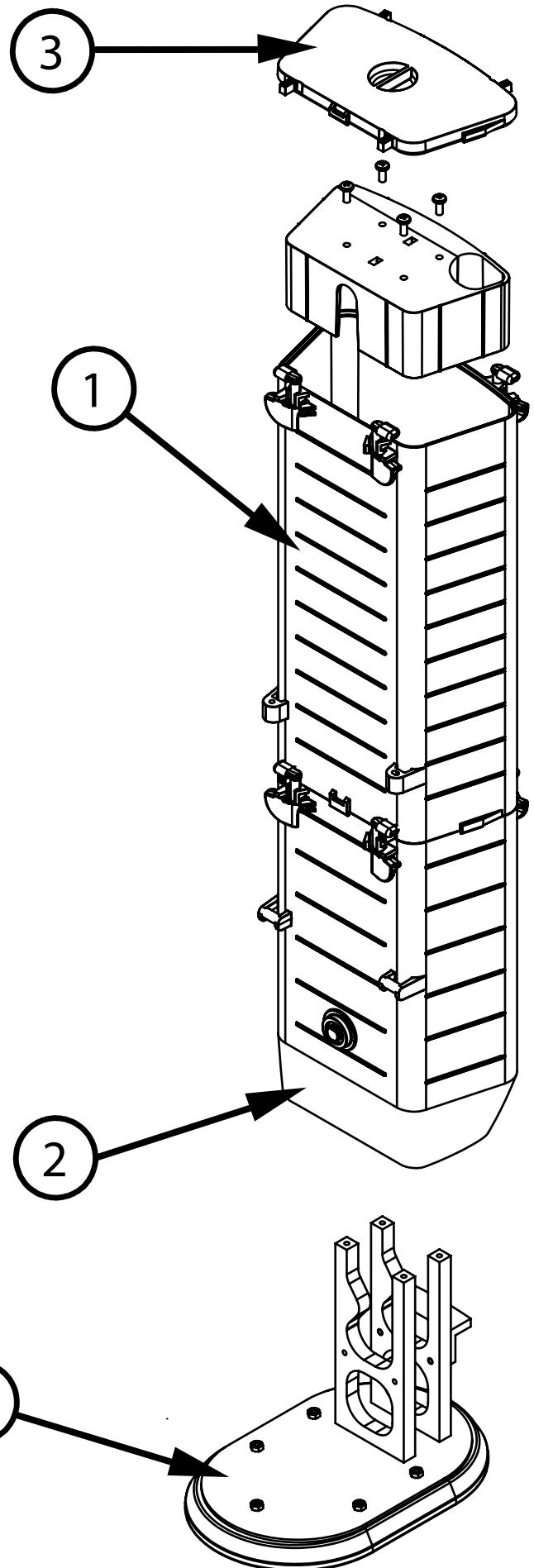
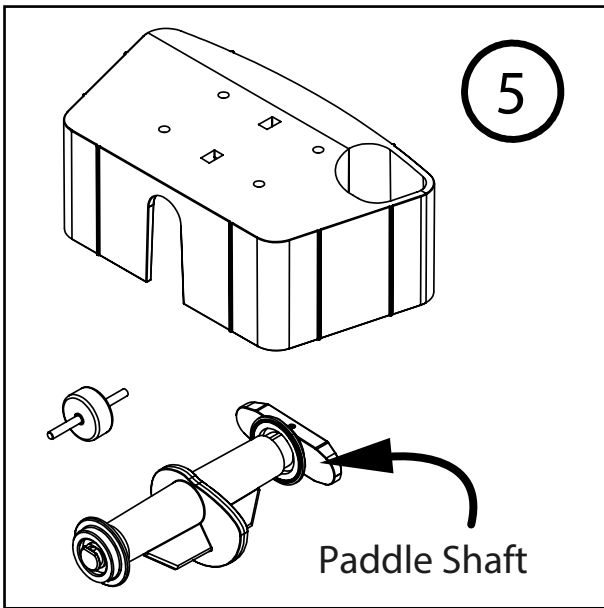

Note: We do not recommend disassembling the home canister. The homing canister must remain in intended location for operation. Food does not load in this canister. Not to be used for dispensing.

Home Canister Layout

Tablet Interface

Tablet interface

Overview:

The tablet is housed within the door panel of the machine. This tablet is not to be removed or tampered with, and is not intended for use

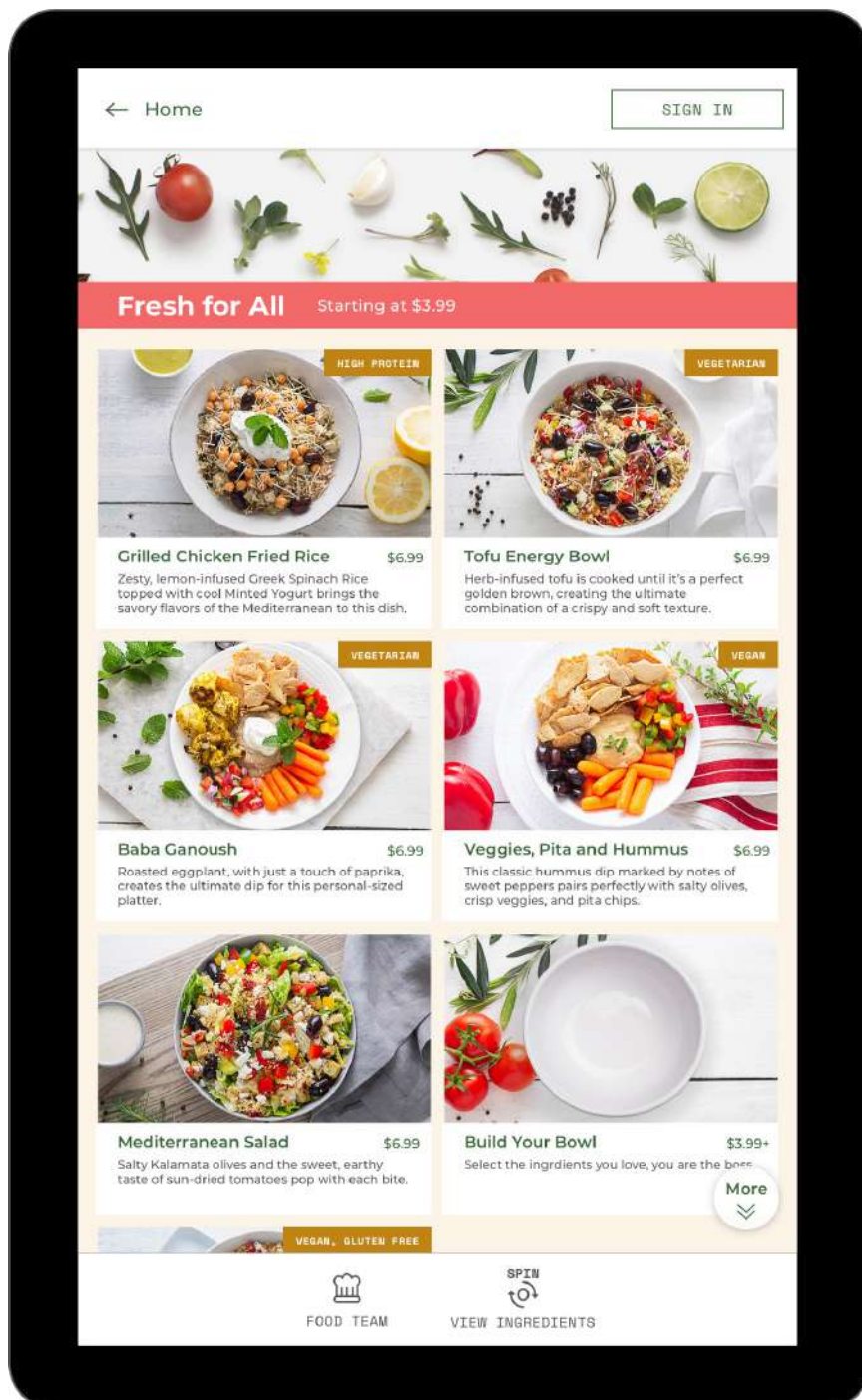

Terms and Writing Conventions

This user guide contains terms and graphical elements. Familiarizing yourself with these terms, elements, and conventions will help you perform tasks outlined throughout this manual.

Robot: Another term used for Sally the Robot.

Press, Tap, Click: Describes actions used to make selections on screen.

Button and/or Icon: Refers to any software graphic that responds when selected.

Screen: An area within the Sally app.

Tablet Keyboard: When typing is required, a hidden software keyboard will emerge from the bottom of the tablet screen.

Disabled/Enabled: When disabled, Sally will have limited functionality. When enabled, Sally will be fully functional.

Filling: Refers to the filling of ingredients into a canister.

Loading: Refers to the installation of a canister into Sally's interior compartment.

Culinary Overview

Please contact your Customer Success Manager for more information regarding ingredient preparation, presentation, and detailed information for dispensing purposes. For additional information feel free to check out our website at <http://chowbotics.com>

Sally is a low maintenance machine, however, there are a few tasks that must be managed regularly. Please review Care & Cleaning recommendations outlined in following sections.

Important

Chowbotics reserves the right to change specifications and product design without notice. Such revisions do not entitle the buyer to corresponding changes, improvements, additions, or replacements for previously purchased equipment.



Basic

c Use



Canister Assembly: Outer Canisters

Note: Assembly instructions for canister hardware must be carefully reviewed. Consult the Quick Reference Guides (included separately) for convenience.

Bottom: (half with a narrowed end): stand in front of you with the wider side facing you.



Paddle: (the hole through it has a flat side): put the paddle into the canister with the wider side matching the wider part of the canister, make sure the paddle hole has the flat side down.

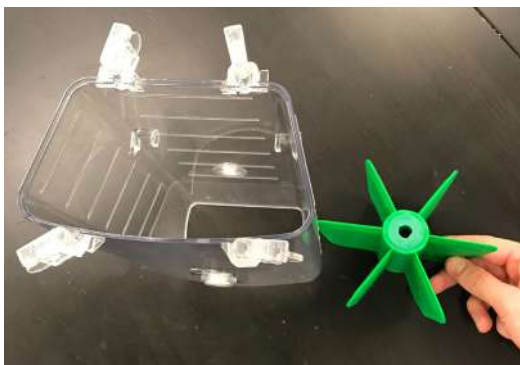

Paddle shaft: also has a flat side that was designed to line up with the flat side on the paddle. Line up all the holes and make sure the flat side of the shaft is down.



Insert the shaft all the way through the canister, keeping the black handle against the wider part of the outer canister or the more narrow part of the inner canister.

Basic Use

Top: place the top half onto the bottom half (wider side facing you). To secure it, swing all four latches away from the center of the canister. Be sure to grip both the top and bottom of the latches. Tip: Nudge the latches upward slightly making it easier to snap them in place.

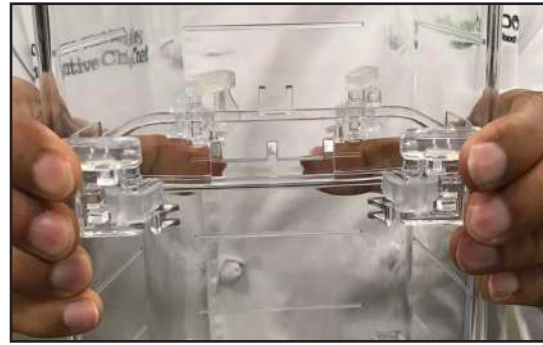
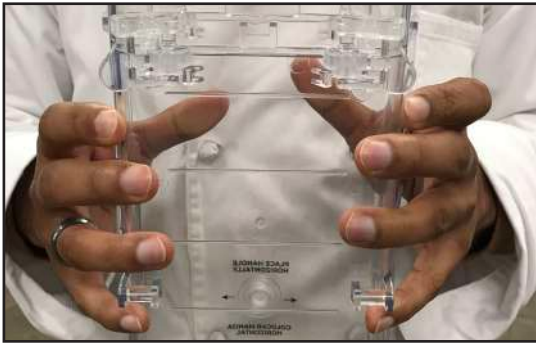

Shufflers: (two clips on top: one wide, one narrow) the top of the canister has grooves on it that align with the clips of the shuffler. If the ingredient for the canister requires a shuffler, be sure that these clip widths match the grooves of the canister. Ingredients that require shufflers will be specified by our Culinary Toolkit (Included Separately).



Lid: place lid into position. Secure the lid in place by swinging all four latches away from the center of the canister. Be sure to grab the top and bottom of the latches.

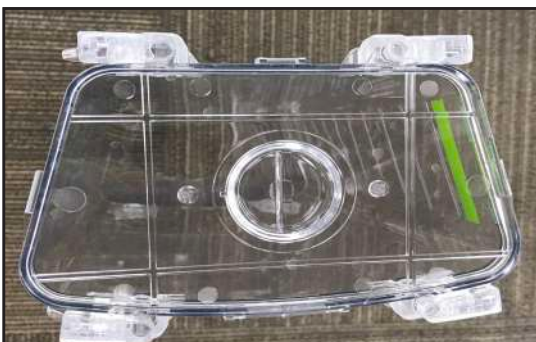

Canister Assembly: Inner Canisters

Note: Assembly instructions for canister hardware must be carefully reviewed. Consult the Quick Reference Guides (included separately) for convenience.

Bottom: (Half with narrowed end): lay flat side down with narrow end facing you.

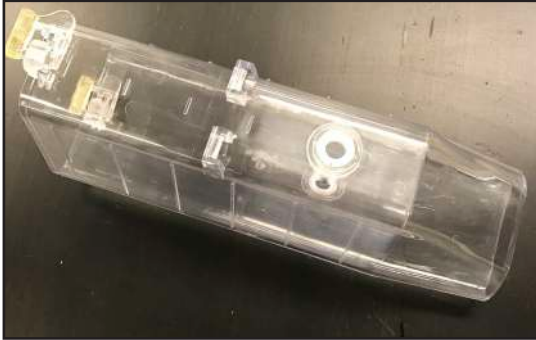

Paddle: (the hole through it has a flat side): Using one hand to hold the canister, put the paddle into the canister with the narrow side facing up, make sure the paddle hole has the flat side down.

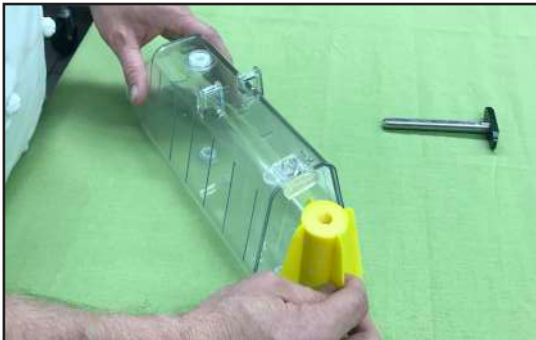

Paddle shaft: also has a flat side that was designed to line up with the flat side on the paddle. Line up all the holes and make sure the flat side of the shaft aligns with the flat side of the hole along the paddle. Insert the shaft all the way through the canister, keeping the black handle on top.



Insert the shaft all the way through the canister, keeping the black handle against the wider part of the outer canister or the more narrow part of the inner canister.

Basic Use

Top: Stand the bottom half upright and put the top on the bottom. To secure it, swing all four latches away from the center of the canister. Be sure to grip both the top and bottom of the latches.

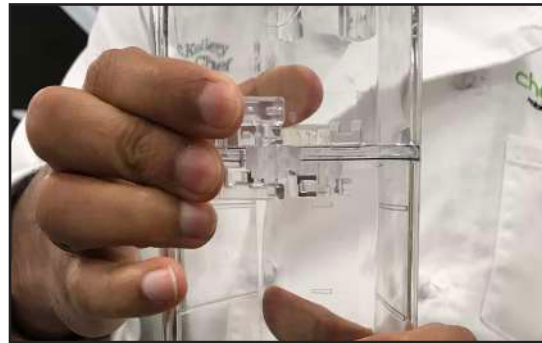

Shufflers: Inner canisters do not require shufflers.

Lid: place the lid into position. Secure the lid in place by swinging all four latches away from the center of the canister. Be sure to grab the top and bottom of the latches.

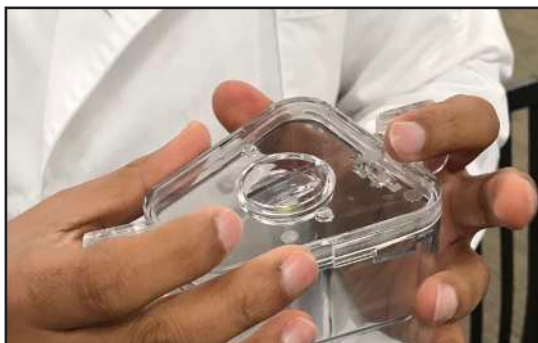

Canister Assembly: Dressing Canister

Note: Assembly instructions for canister hardware must be carefully reviewed. Consult the Quick Reference Guides (included separately) for convenience.

Bottom: Lay with open section facing up.



Hose: Half way down the hose is a ring. This ring seats into a slot at the top of the black pump base. To install hose, start by inserting the ring into the matching slot and continue to work the hose into position along the channel down the black pump base. At the end of the hose, another ring will seat into the accompanying slot at the bottom of the pump base.



Clamp Release: Lift up the knob on the clamp release and swing the clamp shut. The clamp should be pushed down to lock in place.

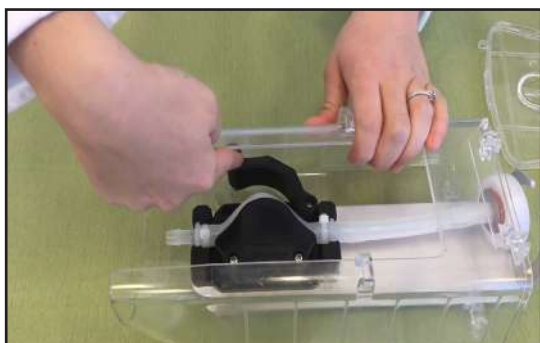

Basic Use

Dressing bottle: Screw the dressing bottle onto the bottle attachment, after this has been screwed in place, dressing can be filled through the top. Screw the bottle lid securely to the top.



Top: Place the top of the canister on the bottom. To secure it, swing all four latches away from the center of the canister. Be sure to grip both the top and bottom of the latches. The lid does not need to be removed from top half of canister.



Home Canister:

Note: The Home Canister is not to be used for ingredient dispensing and should not be loaded with food!

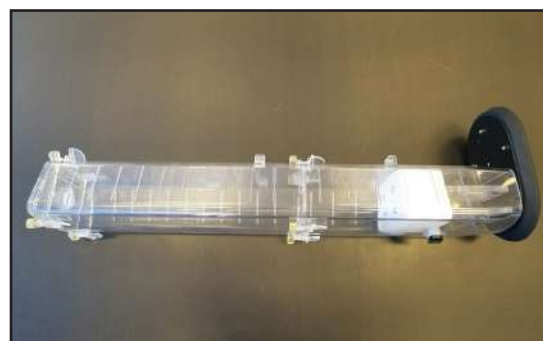

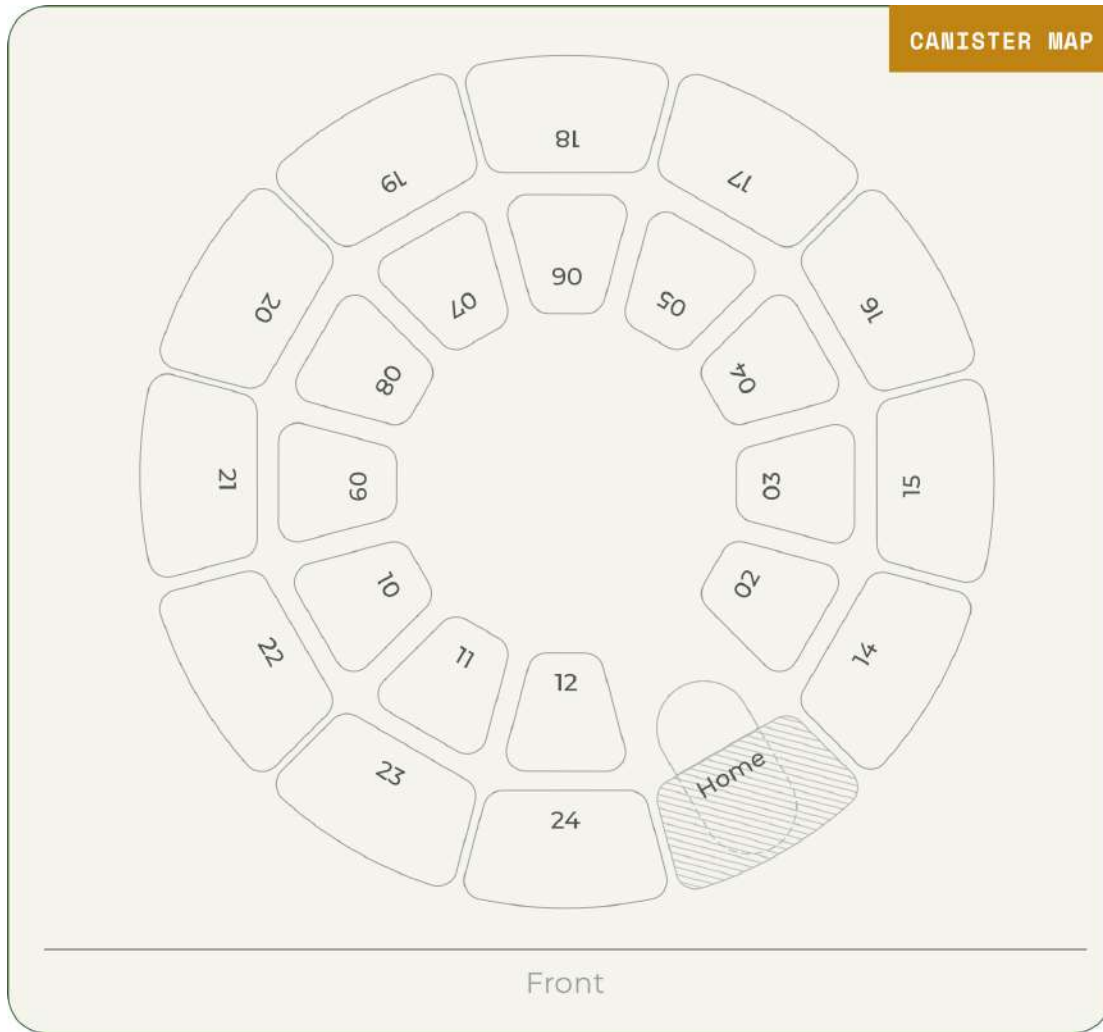

Canister Positions:

In total, there are 22 canister slots available to stock with ingredients.

Canister slots 1 and 13 (not shown in "Restock Sally" directory) are reserved for the Home Canister and are not to be used for ingredient dispensing. This sector of the carousel does not have mounting points in the inner canister slot to accommodate the home canister.

Canisters are listed in a linear fashion by canister number and are sorted by row:

- Inner canisters are labeled 2-12 and can be found along the top row of this screen.
- Outer canisters are labeled 14-24 and can be found along the bottom row of this screen.

When a canister information box is selected, Sally will rotate the carousel and will position the chosen canister slot front and center of the machine.

Basic Use

Filling Canisters:

Note: Make sure to load ingredients into the correct canisters according to spec sheet

Before filling verify shaft handles are flat or use the appropriate canister stand (included). Be aware that inner canisters do not stand upright on their own. **Note: If you have the shaft handle the wrong way, you will have to re-adjust later and may have product fall out of the canisters.**

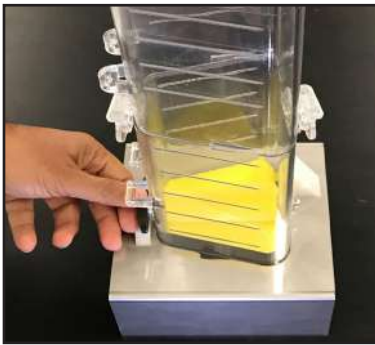

Use the appropriate funnel & stand to fill ingredients quicker and easier (included).

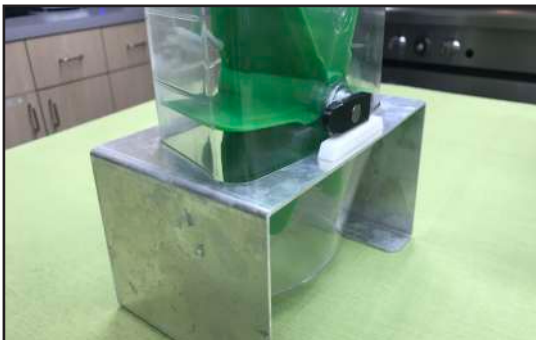

Follow the menu sheet which will have detailed instructions on how to load each of the ingredients. Failure to follow the prep sheet specifically can cause dispensing issues during operation. Making sure that you are using the right type of canister, and in some cases not filling the canister all the way. **Note: Do not packdown/force ingredients, fill only to specified heights.**



Canister Loading Procedure: Mounting Points

1. Once Sally has rotated the chosen canister slot to the front and center of the machine, wait until the machine has come to a complete stop.
2. Unlock the door latches using the key (if applicable) then unlatch the door by lifting the back half of the latch all the way towards you.
3. If loading an inner canister, an outer canister may need to be removed in order to access the inner canister slot. Remove the outer canister and set aside until finished loading the inner canister.

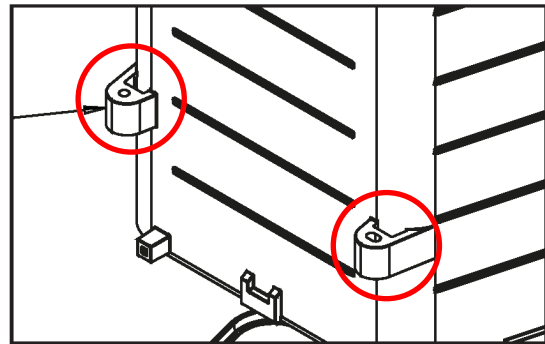
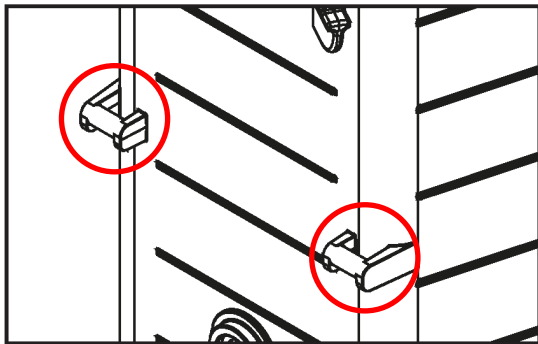

4. Locate the canister mounting points on the back of the canister
5. Two pin mounts near the midsection that coincide with pins located in each canister slot on Sally's Carousel (as shown above).
6. There are two clamp mounts near the bottom that coincide with clamps on the lower mounting points on Sally's Carousel (as shown above).



7. Holding the Canister from the top and bottom, seat the two pin mounts on the canister over the pins on the carousel in the according size canister's slot, and in

Basic Use



the same motion, seat the two clamp mounts into the clamps on the bottom of the carousel.

8. **Important: Test to make sure the canister is secure with a gentle tug on the top and bottom of the canister, there should be minimal movement. Be sure the canister is properly seated into position and firmly mounted in mounting points on the carousel. Improper loading of canister will interfere with the operation of Sally.**
 9. Close the door and return to the canister information screen to continue steps 3-8 for all remaining canisters.
 10. When finished loading ingredients, press the "Save" button and all canister slot information will be stored.
 11. Press the "Back" button to return to the admin home page, Sally will respond by performing a homing operation and will lower the home canister foot when the operation is complete.
-

Locking the Door

To lock or unlock Sally, a physical key must be inserted into a locking mechanism on both door latches to the right of Sally. To lock the door, insert the key into each door latch and rotate clockwise. Rotate counterclockwise to unlock. To replace a missing, damaged, or stolen key, please **contact support at support@chowbotics.com or +1 (831) CHOWBOT (831-246-9268).**



Care & Cleaning



Daily Maintenance Tasks

Why: To reduce the chance of contamination and to maintain equipment operation.

Time required: 2-3 minutes to prepare 15 - 30 minutes to complete.

Time of day: At close (For 24-hour restaurants: During low-volume periods).

WARNING: POWER OFF THE MACHINE DURING CLEANING OR MAINTENANCE TO PREVENT ICE BUILD UP.

Ice build-up can occur if the door is left open while the machine is running or if the home canister cap is not in the lower position over dispensing chute for extended periods (up to 15 mins). Ice build up prevents the machine from running properly and can result in downtime of up to 24 hours to de-ice.

Precaution: Be aware of hands and fingers while handling hardware inside Sally.

Tools and supplies:

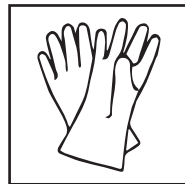

STEPS:

1. Prepare machine for Cleaning
2. Wipe Down Bin (Dispensing Area)
3. Clean Empty Canisters
4. Wipe Down Home Canister Cap
5. Wipe Down Tablet Screen
6. Re-enable the Machine

(1) Prepare The Machine For Cleaning

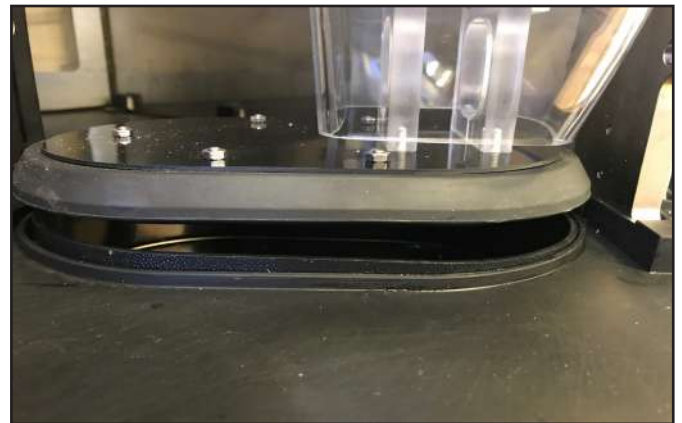

1. **POWER OFF:** From the back exterior panel, flip the on/off switch to power on the machine.
2. **RAISE HOME CANISTER FOOT:** To raise the home canister foot, reach in between the canister and the front motor (outer motor). Grabbing both the motor jaws and the shaft handle together, carefully rotate clockwise (away from you) until you see the home canister foot raise completely. Manually adjust the motor jaws back to a vertical position so the shaft handles may pass through. Test the carousel by carefully and gently turning in either direction; the carousel should move freely and should not feel any resistance or run into the motor jaws .

(2) Wipe Down The Bin (Dispensing Area)

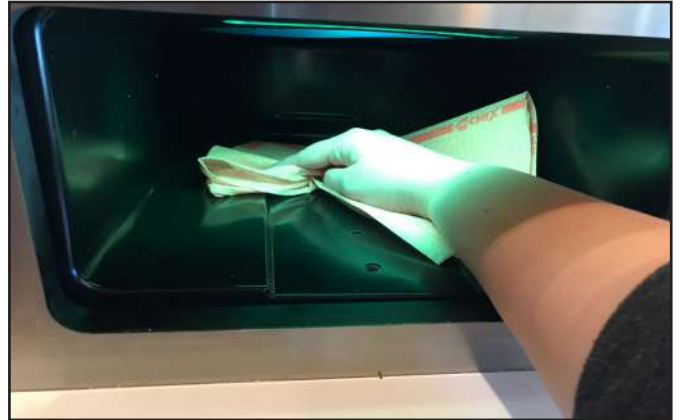

1. Remove the bowl ramp by gently lifting up.
2. Spray a clean, sanitized towel with sanitizer solution.
3. Wipe down the entire bin, making sure to remove any food particles.
4. Wipe down the ramp with a fresh clean, sanitized towel.
5. When complete, reinstall the bowl ramp.

(3) Clean Empty Canisters (Disassembly)

When removing canisters, be sure the door of Sally is not left open unnecessarily to keep the temperature of ingredients as stable as possible.

Disassembly of Outer & Inner Canisters:

Lid: Remove by swinging all four latches towards the center of the canister at the top of the canister. Be sure to grab the top and bottom of the latches. (This component is dishwasher safe.)

Shufflers: Remove applicable shufflers and empty any remaining contents. (This component is dishwasher safe.)



Care & Cleaning

Top: Remove by swinging all four latches towards the center of the canister from the midsection. Be sure to grab the top and bottom of the latches. (This component is dishwasher safe.)

Paddle shaft: Remove by pulling firmly on the shaft handle until the shaft has freed from the canister. (This component is dishwasher safe.)

Paddle: Pull the paddle out. (This component is dishwasher safe.)

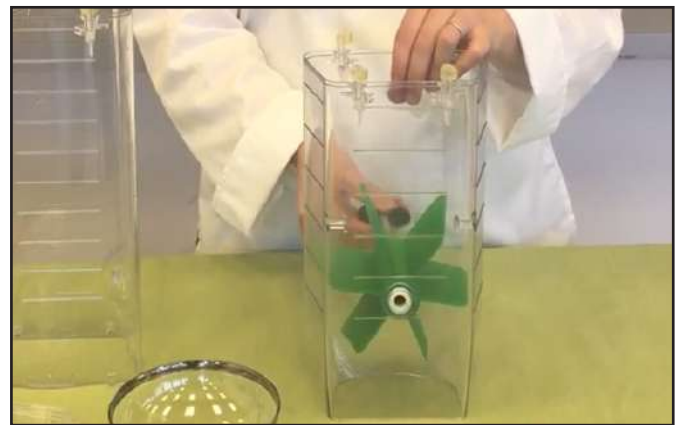

Disassembly of Dressing Canisters:

Top: From the midsection, swing all four latches towards the center of the canister. Be sure to grab the top and bottom of the latches. The lid does not need to be removed. (This component is dishwasher safe.)

Dressing bottle: Turn the entire assembly upside-down. Unscrew the dressing bottle from the bottle attachment. The bottle lid does not need to be removed. (This component is dishwasher safe.)



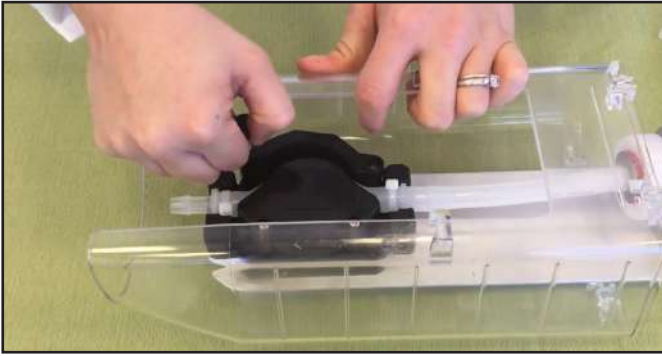

Clamp Release: Lay bottom half of canister with open section facing up. Lift up the knob on the clamp release and swing the clamp open.

Hose & Bottle Attachment: Starting from the bottom of the pump base, pull the hose out of the channel. Use two hands if necessary to free the rest of the piece. (This component is dishwasher safe.) The bottom half does not need to be disassembled further. (This component is dishwasher safe.)

(4) Wipe Home Canister Foot

Although The Home Canister is not to be used for ingredient dispensing and should not be loaded with food, the rubber foot needs to be cleaned regularly.

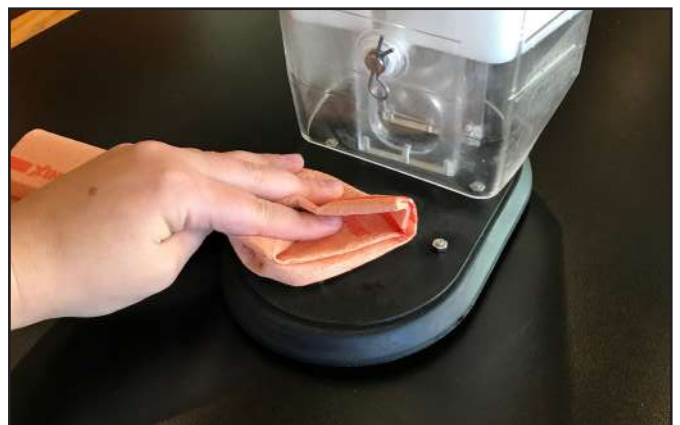

1. Remove the home canister from the carousel.
2. Spray a clean, sanitized towel with sanitizer solution.
3. Wipe down the entire foot (bottom and top), making sure to remove any food particles.
4. When complete, reload the home canister. **Be sure the shaft handle is horizontal and the foot is in the raised position.**

(5) Wipe Down Tablet Screen

Using a microfiber cloth, gently wipe down the tablet display and remove any fingerprints present. **Note: Do not use paper-based wipes. Do not use Windex, or any other alcohol-based cleaning solution.**

(6) Re-Enable the machine

Make sure all black shaft handles are horizontal. **Important: Improper loading of canisters will interfere with the operation of Sally.**

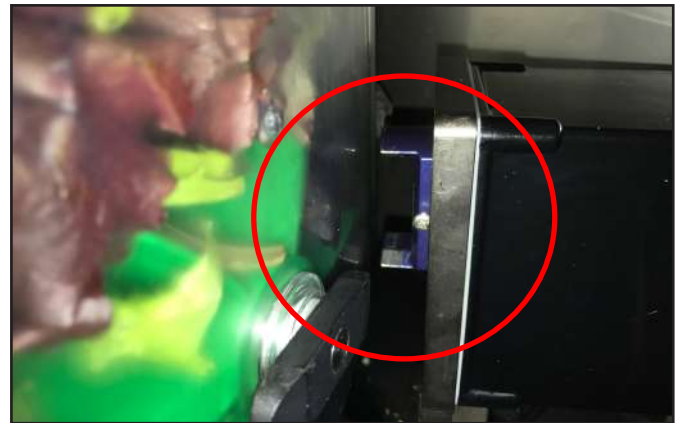

5. If a shaft handle is within reach of the motor jaws, gently and carefully move the carousel so that the motor jaws are clear. Double check that the jaws are vertical so the shaft handles may pass through. **Note: Failure to do so will interfere with the operation of Sally.**
6. Power on the machine.
7. After automatically launching the app, Sally will respond by homing and will end at the user home page.
8. If a receipt printer is connected, be sure the blue light is on before continue normal operation (See “Connecting to Bluetooth” for more information).

Weekly Maintenance Task

Why: To reduce the chance of contamination and to maintain equipment operation

Time required: 2-3 minutes to prepare 15 - 30 minutes to complete (including weekly tasks)

Time of day: At close (For 24-hour restaurants: During low-volume periods)

WARNING: POWER OFF THE MACHINE DURING CLEANING OR MAINTENANCE TO PREVENT ICE BUILD UP.

Ice build-up can occur if the door is left open while the machine is running or if the home canister cap is not in the lower position over dispensing chute for extended periods (up to 15 mins). Ice build up prevents the machine from running properly and can result in downtime of up to 24 hours to de-ice.

Precaution: Be aware of hands and fingers while handling hardware inside Sally.

Tools and supplies:

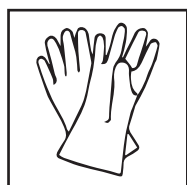

STEPS:

1. Prepare machine for Cleaning
2. Remove the Mat
3. Wash the Mat
4. Re-install the Mat
5. Re-enable the Machine

Sally Interior Mat

This mat is a custom designed single piece of silicone rubber, engineered to snugly fit on the floor of Sally's interior compartment. When installed correctly, the mat should lay flat. The mat is dishwasher safe or can be cleaned using the three compartment sink method. Be sure to allow the mat to air dry completely before re-installing.

(1) Prepare The Machine For Cleaning

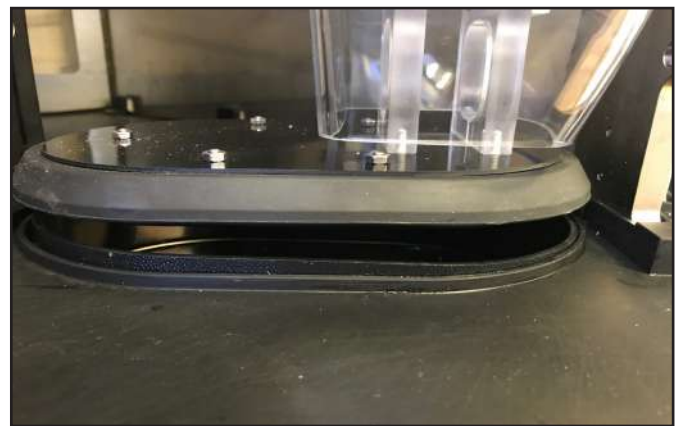

1. **POWER OFF:** From the back exterior panel, flip the on/off switch to power on the machine.
2. **RAISE HOME CANISTER FOOT:** To raise the home canister foot, reach in between the canister and the front motor (outer motor). Grabbing both the motor jaws and the shaft handle together, carefully rotate clockwise (away from you) until

(2) Removing the Mat



1. Reach into the gap at the base of the wheel and pop the flap out to right side.
2. Peel the front right corner and fold right to left.

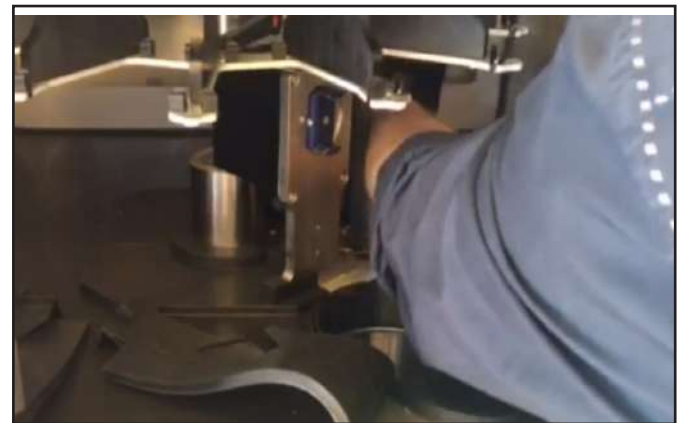

3. Carefully peel the two flaps along either side of the guide rail backwards.
4. From behind the dispensing opening, start at the front right corner and roll the mat backwards into the back right corner. Continue rolling the mat by maneuvering along the back behind the wheel base to the left and back around to the front left corner.
5. Grabbing the entire mat together, it can now be easily removed from the interior compartment for cleaning.

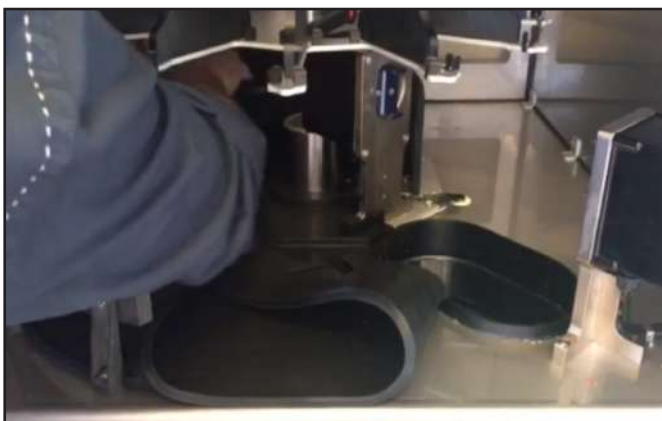

(3) Wipe Down Interior Compartment Floor

1. Spray a clean, sanitized towel with sanitizer solution.
2. Wipe down the entire surface, making sure to remove any food particles.
3. Allow surface to dry before re-installing the mat.

(4) Re-installing the Mat

When upright, the mat should align with the layout of the interior compartment floor. The dispensing opening should be on the front right corner to you when facing the mat.



1. Take the right side of the mat and fold over onto the left.
2. Next, fold the mat forward, make a quarter square of its initial size.
3. Carefully pick up the mat and take it to Sally's interior compartment for installation, making sure the bottom of the bundle is set down in the front left corner between the middle wheel and the guide rail.
4. Unfold the mat once towards the back wall.
5. Next, reach around and uncoil the back behind the wheel.



- Continue aligning the mat along the back of Sally, working your way towards the front along the right side. **Note: all the brackets along the floor of the compartment should fit perfectly with the slots on the mat, the mat should lay flat.**
- Lastly, tuck the flap in the center of the mat into the gap at the base of the wheel, making sure it lays flat.

(5) Re-Enable the machine

Make sure all black shaft handles are horizontal. **Important: Improper loading of canisters will interfere with the operation of Sally.**

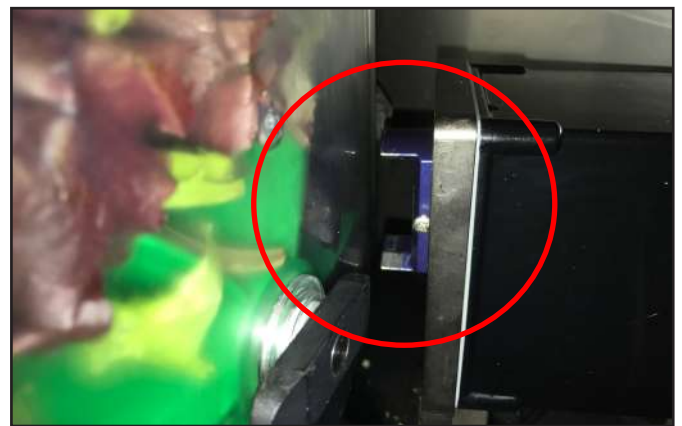

- If a shaft handle is within reach of the motor jaws, gently and carefully move the carousel so that the motor jaws are clear. Double check that the jaws are vertical so the shaft handles may pass through. **Note: Failure to do so will interfere with the operation of Sally.**
- Before loading canister, identify the home canister slot along the carousel. The home canister slot is missing canister mounting points along the inner side of the slot. Once the correct slot has been located, reload the home canister. **Be sure the shaft handle is horizontal and the foot is in the raised position.**
- Power on the machine.
- After automatically launching the app, Sally will respond by homing and will end at the user home page.
- If a receipt printer is connected, be sure the blue light is on before continue normal operation (See "Connecting to Bluetooth" for more information).

Feel free to contact support with any questions about the Sally Mat **contact us at support@chowbotics.com or call us at +1 (831) 246-9268.**

Monthly Maintenance Tasks

Why: To reduce the chance of contamination and to maintain equipment operation

Time required: 2-3 minutes to prepare 10 minutes to complete

Time of day: At close (For 24-hour restaurants: During low-volume periods)

WARNING: POWER OFF THE MACHINE DURING CLEANING OR MAINTENANCE TO PREVENT ICE BUILD UP.

Ice build-up can occur if the door is left open while the machine is running or if the home canister cap is not in the lower position over dispensing chute for extended periods (up to 15 mins). Ice build up prevents the machine from running properly and can result in downtime of up to 24 hours to de-ice.

Precaution: Be aware of hands and fingers while handling hardware inside Sally.

Tools and supplies:

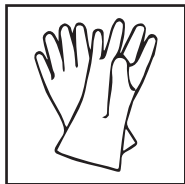

STEPS:

1. Prepare machine for Cleaning
2. Clean Lower Deck
3. Clean Dispensing Chute
4. Clean the Bin Tray
5. Wipe Down Interior Walls
6. Re-enable the Machine

(1) Prepare the Machine for Cleaning

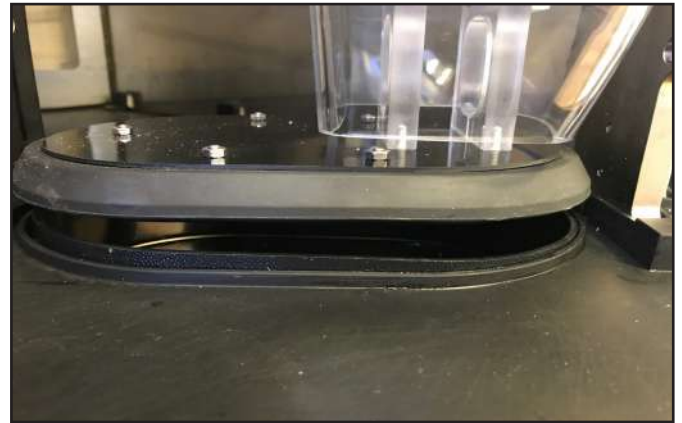

1. **POWER OFF:** From the back exterior panel, flip the on/off switch to power on the machine.
2. **RAISE HOME CANISTER FOOT:** To raise the home canister foot, reach in between the canister and the front motor (outer motor). Grabbing both the motor jaws and the shaft handle together, carefully rotate clockwise (away from you) until you see the home canister foot raise completely. Manually adjust the motor jaws back to a vertical position so the shaft handles may pass through. Test the carousel by carefully and gently turning in either direction; the carousel should move freely and should not feel any resistance or run into the motor jaws.
3. **REMOVE ALL CANISTERS:** Remove all canisters from the carousel and set aside. This includes the Home Canister.

(2) Clean Lower Deck



1. Spray a clean, sanitized towel with sanitizer solution.
2. With one hand, gently lift up the bundle of wires on the floor of the lower deck.
3. With the other hand, clean the entire floor by gently wiping under the wiring and

(3) Clean the Dispensing Chute

Remove any canisters that block access to the dispensing chute and set aside. Spray a clean, sanitized towel with sanitizer solution. Wipe down the walls of the chute, making sure to remove any food particles.



under the bin tray, making sure to remove any food particles.

(4) Clean the Bin Tray

1. Remove the bowl ramp by gently lifting the part out of the bin.
2. Unscrew the two thumbscrews on the front of the bin and set aside.



3. Pull out the bin and set aside.

-
4. Spray a clean, sanitized towel with sanitizer solution.
 5. Wipe down the entire bin, making sure to remove any food particles.
 6. Wipe down the ramp with a fresh clean, sanitized towel.
 7. Return the bin to the bin tray by aligning the thumbscrew holes that match on the front of the bin tray.
 8. Secure in place with the two thumbscrews.
 9. When complete, Insert the bowl ramp.

(5) Wipe Down Interior walls

1. Spray a clean, sanitized towel with sanitizer solution.
2. Wipe down the all the interior walls, making sure to remove any food particles. If it is difficult to reach certain spots, we recommend using a stool or small ladder.
Note: Do not lean heavily on the machine to reach.
3. For a deep clean, wipe down the guide rail and the upper level of the carousel.



(6) Re-Enable the machine

Make sure all black shaft handles are horizontal. **Important: Improper loading of canisters will interfere with the operation of Sally.**



1. If a shaft handle is within reach of the motor jaws, gently and carefully move the carousel so that the motor jaws are clear. Double check that the jaws are vertical so the shaft handles may pass through. **Note: Failure to do so will interfere with the operation of Sally.**
2. Power on the machine.
3. After automatically launching the app, Sally will respond by homing and will end at the user home page.
4. If a receipt printer is connected, be sure the blue light is on before continue normal operation (See “Connecting to Bluetooth” for more information).

Feel free to contact support with any questions about the Sally Mat **contact us at support@chowbotics.com or call us at +1 (831) 246-9268.**



Troubleshooting

Ingredient Not Dispensing

Caution: Be aware of hands and fingers while handling hardware inside Sally.

Symptom	Possible Cause	Check	Remedy
Ingredient not dispensing	an ingredient has clumped	From the Sally App, navigate to the admin page. Choose "Restock Sally." Select the canister information box for the ingredient in question. Check to see if the ingredient in the canister has clumped together. There might be a gap between the paddle fins and the ingredient as an indicator.	Some ingredients require daily management to prevent clumping. First, remove the canister. Hold onto the shaft handle to prevent any rotation and gently tip the canister upside-down and back a few times until pieces have separated. A gentle shake will also work. Make sure the shaft handle is horizontal before reloading the canister.
	Wrong ingredient is in the canister slot for that selection	From the Sally App, navigate to the admin page. Choose "Restock Sally" from the admin navigation bar. Select the canister information box for the ingredient in question. Check to see if the ingredient in the canister is the same as the ingredient registered to that canister slot. (Note: Outer canisters will need to be removed to access inner canisters).	If the wrong ingredient is in the canister slot, it is likely that another canister slot will need to be reconfigured or exchanged. Double check each ingredient registered to each canister slot. (Note: Outer canisters will need to be removed to access inner canisters).

Ingredient is Dispensing too Much or too Little

Caution: Be aware of hands and fingers while handling hardware inside Sally.

Symptom	Possible Cause	Check	Remedy
Ingredient is dispensing too much or too little	Ingredients was improperly prepared or is not to specifications.	Consult your customer success manager	If possible, correct the issue for the ingredient and reload the canister. If unable to correct the issue or if ingredient is still not to specifications, we recommend removing the ingredient from the menu (as well as the selected ingredients list in the "ingredient selection" screen).
	Wrong ingredient is in the canister slot for that selection.	From the Sally App, navigate to the admin page. Choose "Restock Sally." Select the canister information box for the ingredient in question. Check to see if the ingredient in the canister is the same as the ingredient registered to that canister slot. (Note: Outer canisters will need to be removed to access inner canisters).	If the wrong ingredient is in the canister slot, it is likely that another canister slot will need to be reconfigured or exchanged. Double check each ingredient registered to each canister slot. (Note: Outer canisters will need to be removed to access inner canisters).
	Weight value for that ingredient had been adjusted to dispense more/less of that ingredient per serving.	From the Sally App, navigate to the admin page. Navigate to "Ingredient Selection" and select an individual ingredient to see the weight and price value for this ingredient.	Consult Customer Success Manager to confirm default weight values for the ingredient in question. Modify the weight value if needed. Press "+ADD" when finished.

Loading Error Detected/ Loud Noise

Caution: Be aware of hands and fingers while handling hardware inside Sally.

Symptom	Possible Cause	Check	Remedy
Loading Error detected/ Loud noise	Canister shaft handles unable to pass through motor	Test if carousel is able to make a full revolution without any conflict.	Identify which shaft handle is vertical and rotate to a horizontal position. Note: some ingredients may pass through paddle when rotating.
	Canister improperly loaded onto carousel		Identify which canister is not properly mounted and reseal into both mounting points. Test to make sure the canister is secure with a gentle tug on the top and bottom of the canister, there should be minimal movement.
	Foreign object inside interior compartment		Identify possible foreign object (such as cleaning equipment or other item) and remove from interior compartment.
	The motor needs to be adjusted		Manually adjust the motor to a vertical position so the shaft handles may pass through. Note: For inner motor adjustments, remove the home canister to access the motor.
	Motor Jig needs to be adjusted		At the top of the outer motor are two adjustment screws. Relocate the position of these screws along the jig mount so that canisters can pass by the nose of the jig.

App Crash/ Unresponsive

Caution: Be aware of hands and fingers while handling hardware inside Sally.

Symptom	Possible Cause	Check	Remedy
App crash/ App Unresponsive	Program has timed out	N/A	Restart the machine by powering off then back on again.
	Software and/or firmware is out of date	Check if there is an available software or firmware update	Update to the latest version of software/firmware or contact support.

Machine Not Moving/ Unresponsive

Caution: Be aware of hands and fingers while handling hardware inside Sally.

Symptom	Possible Cause	Check	Remedy
Machine Not Moving/ Unresponsive	Temperature unstable/too high	<p>Check temperature reading (rear LCD panel or through the app). Sally will not operate when the temperature reaches 45°F (7°C) or higher for a period of 15 mins or longer.</p> <p>Check that the home canister cap is in the lowered position over the dispensing chute.</p> <p>Note: This may happen if Sally's door has been left open while the machine is running, (ex: while cleaning or when loading canisters).</p> <p>Note: Sally will provide an additional 30 minute grace period after restocking canisters to reach a safe operating temperature.</p>	<p>Note: depending on the length of time ingredients have been at a higher temperature, ingredients may have been compromised and will need to be replaced.</p> <ol style="list-style-type: none"> Keeping the door closed and the insulation cap in the lowered position, wait for Sally to reach safe operating temperature (41-44°F or 3-6°C). If after 1 hour Sally is unable to reach a safe operating temperature, contact support for further instruction.
	Machine is disabled	<p>Check if there is a "Machine is disabled" message on the screen.</p>	<p>Re-enable the machine from the error message window. Sally should begin to rotate and return to the home canister when this operation is complete.</p>
	Collision detected	<p>Test if carousel is able to make a full revolution without any conflict.</p>	<p>Consult "Collision Detected" Troubleshooting guide.</p>
	Software and/or firmware is out of date	<p>Check if there is an available software or firmware update.</p>	<p>Update to the latest version of software/firmware or contact support.</p>

Receipt Not Printed

Caution: Be aware of hands and fingers while handling hardware inside Sally.

Symptom	Possible Cause	Check	Remedy
Receipt not printed	Not connected to bluetooth	<ol style="list-style-type: none"> 1. Make sure the printer is powered on. 2. Is there a blue light illuminated on the printer? 	<ol style="list-style-type: none"> 1. If the blue light is off, try powering the printer off then on before attempting to reconnect. 2. If blue light is on, the receipt printer may need to be re-connect through the app. Contact support for further instruction. (Note: you may need to power the printer off then on to re-connect successfully).
	Receipt paper is out/ Jammed	<p>Check the paper by depressing the printer hood release button (The machine will make a loud beep until closed).</p>	<ol style="list-style-type: none"> 1. If the paper is out, refill with the correct receipt paper and close the hood. (DO NOT DISCARD the receipt paper dowel inside the roll). 2. If jammed, unroll enough of the receipt paper to clear the jam. Close the hood when finished.

Need Help?

Please [contact support at +1 \(831\) CHOWBOT \(831-246-9268\)](tel:+1831469268) or reach us at support@chowbotics.com if you have any questions or are unable to resolve an issue.

It is always helpful to have the Sally Number (found on the inside of door panel) handy when calling.

When calling for help with a problem, please give as much information pertaining to the nature of the trouble as possible. This might include examples of what is or is not happening, and troubleshooting steps taken, if applicable.



Contact

**Do you have Questions?
Contact US.**

1 (831) 246-9268 (Technical Support)

Support@chowbotics.com

Info@chowbotics.com



Link : <http://www.chowbotics.com>

Call: +(831) 246-9268



By Chowbotics

Address

Chowbotics
1718 Broadway
Redwood City, CA

Contact

+1 (831) 246-9268
Support@chowbotics.com

Online

Email : info@chowbotics.com
Website: www.chowbotics.com