

# 3M™ Water Filtration Products

## TFS450 Reverse Osmosis Water Filtration System Owners Manual

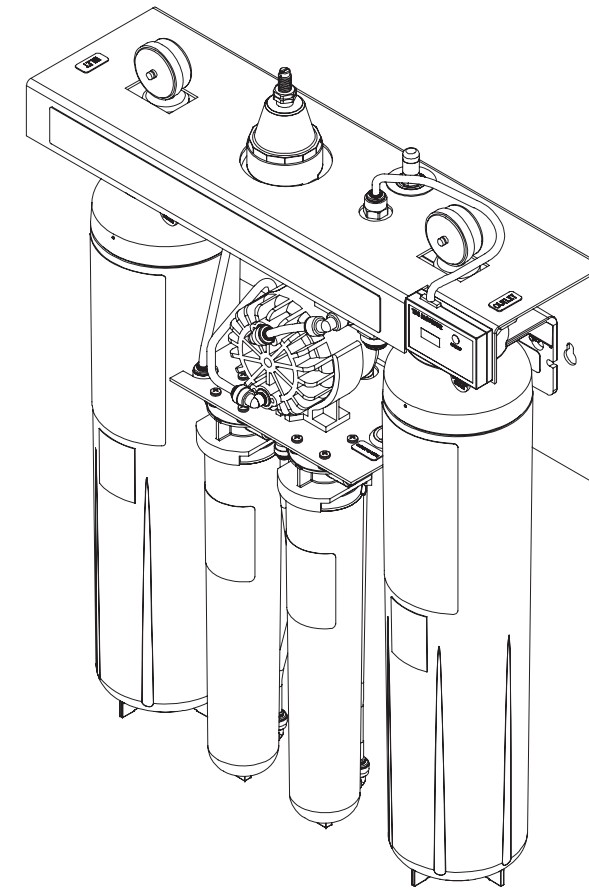

Congratulations on the purchase of the 3M TFS450 reverse osmosis water filtration system.

This system incorporates many unique features to provide the highest quality product while reducing operating and maintenance costs associated with foodservice equipment. The TFS450 system delivers Recipe Quality Water™ for better tasting premium coffee and other beverages and for reduced equipment maintenance costs due to the reduction in lime scale formation.



**3M Purification Inc.**  
400 Research Parkway  
Meriden, CT 06450, USA  
Toll Free: 866.990.9785  
Worldwide: 203.237.5541  
Fax: 203.238.8701  
[www.3Mfoodservice.com](http://www.3Mfoodservice.com)  
[www.3Mpurification.com](http://www.3Mpurification.com)

Schrader is a trademark of Schrader-Bridgeport International, Inc.  
Recipe Quality Recipe is a trademark of 3M Company used under license.  
3M is a trademark of 3M Company.  
© 2012 3M Company. All rights reserved.  
INSTR4321 0812B  
Please Recycle. Printed in U.S.A.

**Installer:** Please leave with owner.

**Owner:** Please retain for operation and future maintenance instructions.



# Table of Contents

Preface

Safety Information.....Page 3

    Page 4

TFS450 System Overview .....Page 5

Parts List.....Page 5

TFS450 RO Filtration System Diagram.....Page 6

Installation and Plumbing Diagrams .....Page 7

Installation Kit .....Page 7

Feedwater Parameters.....Page 8

Equipment Set-up and Installation.....Page 8

- Equipment Location .....Page 8
- Mounting the TFS450 RO Filtration System.....Page 8
- Plumbing Connections .....Page 9
- Storage Tank Connections.....Page 9
- How To Use “Push-In” Fittings .....Page 10

Installation of Filter Cartridges.....Page 10

- Pre-filter Cartridge .....Page 10
- Final (Post) Filter Cartridge .....Page 11
- Reverse Osmosis Cartridges (2) .....Page 11

Start-Up Procedure .....Page 11

- Tank Air Charge Adjustment.....Page 11
- Adjustment of TDS (Total Dissolved Solids) Using the Blending Valve.....Page 12
- Automatic Bypass Pressure Adjustment.....Page 12

Cartridge Change Procedure.....Page 13

- De-Pressurization Process.....Page 13
- Pre-filter Cartridge Replacement Procedure .....Page 13
- Final (Post) Filter Cartridge Replacement Procedure .....Page 13
- Reverse Osmosis Membrane Replacement Procedure .....Page 13
- Restarting and Purging the TFS450 RO Filtration System.....Page 13

Troubleshooting Guide .....Page 14

TFS450 RO Filtration System Replacement Parts.....Page 15

Limited Warranty.....Page 15

## Replacement Parts

For replacement parts/service call 866.990.9785 or visit [www.3Mfoodservice.com](http://www.3Mfoodservice.com) for a parts distributor and/or service representative nearest your location.

Cartpak with All Four Cartridges	56248-01
Cartpak with two RO Membranes (90%)	56248-02

Item	Description	Part Number
1	Pre-filter Cartridge HF95	56135-07
2	Final (Post) Filter Cartridge HF90	56135-03
3	RO Membrane 90% (2 req.)	56250-01
3 Alternate	RO Membrane 95% (2 req.)	56987-16
4	Permeate Pump	89-1331202
5	TDS Meter	
6	Pressure Gauge (2 req.)	
7	Pressure Regulator	
9	½” Ball Valve (Not Shown)	
10	Bypass Plug (Not Shown)	85-8510

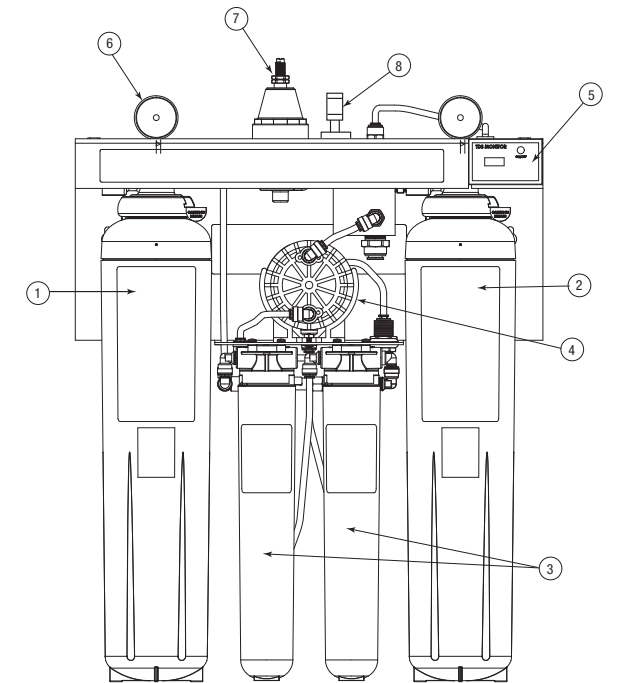

**Limited Warranty:** 3M Purification Inc. warrants the TFS450 reverse osmosis water filtration system only to be free from defects in material and workmanship for one (1) year from the date of purchase. The disposable filter cartridge is warranted from defects in material and workmanship for a period of one (1) year from the date of purchase. This warranty does not cover failures resulting from abuse, misuse, alterations or damage not caused by 3M Purification Inc. or failure to follow installation and use instructions. No warranty is given as to the service life of any filter cartridge or membrane as it will vary with local water conditions and consumption. **3M PURIFICATION INC. MAKES NO OTHER WARRANTIES OR CONDITIONS, EXPRESS OR IMPLIED, INCLUDING, BUT NOT LIMITED TO, ANY IMPLIED WARRANTY OR CONDITION OF MERCHANTABILITY OR FITNESS FOR A PARTICULAR PURPOSE OR ANY IMPLIED WARRANTY OR CONDITION ARISING OUT OF A COURSE OF DEALING, CUSTOMER OR USAGE OF TRADE.** If the Products fails to satisfy this Limited Warranty during the warranty period, 3M Purification Inc., at it's option, will replace the Product or refund your Product purchase price. This warranty does not cover labor. **The remedy stated in this paragraph is Customer's sole remedy and 3M Purification Inc.'s exclusive obligation. For additional information, see the entire Limited Warranty located in the product Installation and Operation Instruction Manual.**

This warranty gives you specific legal rights, and you may have other rights which may vary from state to state, or country to country. For any warranty questions, please call 866.990.9785 or mail your request to: Warranty Claims, 3M Purification Inc., 400 Research Parkway, Meriden, CT 06450. Proof of purchase (original sales receipt) must accompany the warranty claim, along with a complete description of the Product, model number and alleged defect.

**Limitation of Liability.** 3M Purification Inc. will not be liable for any loss or damage arising from this 3M Purification Inc. product, whether direct, indirect, special, incidental, or consequential, regardless of the legal theory asserted, including warranty, contract, negligence or strict liability. Some states and countries do not allow the exclusion or limitation of incidental or consequential damages, so the above limitation or exclusion may not apply to you.

## Troubleshooting Guide

Problem	Potential Cause	Corrective Action	Notes
Units Run Low or Out of Water	Storage tank undersized	Install additional storage tank capacity	Contact Dealer
	Low Feed Water Pressure	Add TFS450-BP Water Booster Pump	
	RO Membranes Fouled	Replace RO Membranes	Feed Water Pressure, Temperature, Production Flow Rate and Reject Flow Rate should be checked before replacing membrane
		Ensure Reject Flow Line is not kinked or plugged. Replace if needed. (3/8" OD tube minimum diameter required)	
	Storage Tank Air Charge is over 30 psi (207 kPa)	Drain tank using sample valve. With sample valve open to reduce the air charge using the Schrader Air Valve, 28-30 psi (193-207 kPa). Close sample valve .	Unscrew Blue Cap to access a Schrader Air Valve
	Pre-filter or (post) Final Filter is plugged by particulate (Particles) (see note 1)	Replace Pre-filter Cartridge Replace Post-filter	A more frequent Pre-filter and Post-filter change-out schedule may be needed (see note 1)
Slow leak in the Distribution Line	Repair Leak	The unit produces filtered water slowly. A dripping leak can prevent the tank from filling.	
TDS of Product Water too Low	Blend too low	Re-adjust Blending Valve to allow more blending	Use adjustment procedure on page 12.
TDS of Product Water too High	Blending too high	Re-adjust Blending Valve to allow less blending	Use adjustment procedure on page 12.
TDS of Product Water too High with no blending	RO Membranes fouled	Replace RO membranes (see note 2) with higher (95% retention rating).	Pre-treat with a Water Softener
TDS meter not Operating	Low Battery	Replace batteries	

(1) **IMPORTANT NOTE:** The differential pressure (hence the degree of plugging) across the Pre-filter may be measured and monitored by the difference between the inlet water pressure and the pressure at the gauge atop the Pre-filter cartridge when the system is running. Similarly for the Final (Post) filter by the difference between the two pressure gauges on top of the TFS450 Filtration System.

(2) See Replacement Parts List for 95% Retention RO Filters.

## Safety Information

Read, understand and follow all safety information contained in these instructions prior to installation and use of the 3M TFS450 reverse osmosis water filtration system. Retain these instructions for future reference.

### Intended use:

The TFS450 is intended for use in filtering potable water for foodservice coffee, espresso, cold beverage, and steamer equipment and has not been evaluated for other uses. The system must be installed indoors near the point-of-use and must be installed by qualified professional installers according to these installation instructions.

EXPLANATION OF SIGNAL WORD CONSEQUENCES	
 <b>WARNING</b>	Indicates a potentially hazardous situation, which, if not avoided, could result in death or serious injury and/or property damage.
<b>CAUTION</b>	Indicates a potentially hazardous situation, which, if not avoided, may result in property damage.

 <b>WARNING</b>	
<b>To reduce the risk associated with choking:</b>	
<ul style="list-style-type: none"> <li>Do not allow children under 3 years of age to have access to small parts during the installation of this product.</li> </ul>	
<b>To reduce the risk associated with ingestion of contaminants:</b>	
<ul style="list-style-type: none"> <li>Do not use with water that is microbiologically unsafe or of unknown quality without adequate disinfection before or after the system. Systems certified for cyst reduction may be used on disinfected water that may contain filterable cysts. EPA Establishment Number 070595-CT-001</li> <li>An approved air gap must exist between the RO System reject drain line and the drain opening to meet plumbing codes.</li> </ul>	
<b>To reduce the risk associated with hazardous voltage due to an installer drilling through existing electric wiring or water pipes in the area of installation:</b>	
<ul style="list-style-type: none"> <li>Do not install near electric wiring or piping which may be in path of a drilling tool when selecting the position to mount the filter bracket.</li> </ul>	
<b>To reduce the risk of physical injury:</b>	
<ul style="list-style-type: none"> <li>Shut off inlet water supply and depressurize system as shown in manual prior to cartridge removal.</li> <li>All hydro-pneumatic pressurized tanks must have an appropriate pressure relief valve installed.</li> </ul>	
<b>To reduce the risk associated with back strain:</b>	
<ul style="list-style-type: none"> <li>Follow safe lifting procedures.</li> </ul>	
<b>To reduce the risk of injury with household bleach:</b>	
<ul style="list-style-type: none"> <li>Read and follow manufacturers directions and cautions.</li> <li>Keep out of reach of children.</li> <li>Do not intermix with other chemicals.</li> </ul>	

## CAUTION

### To reduce the risk associated with property damage due to water leakage:

- **Read and follow** Use Instructions before installation and use of this system.
- Installation and use **MUST** comply with all state and local plumbing codes.
- Before installation, shut-off main water supply and depressurize and drain pipes.
- **Protect from freezing**, remove filter cartridge when temperatures are expected to drop below 40° F (4.4° C).
- **Do not install** systems in areas where ambient temperatures may go above 110° F (43.3° C).
- **Do not install** on hot water supply lines. The maximum operating water temperature of this filtration system is 100°F (37.8°C).
- **Do not install** if water pressure exceeds 100 psi (689 kPa). If your water pressure exceeds 80 psi (552 kPa), you must install a pressure limiting valve. Contact a plumbing professional if you are uncertain how to check your water pressure.
- **Do not install** where water hammer conditions may occur. If water hammer conditions exist you must install a water hammer arrester. Contact a plumbing professional if you are uncertain how to check for this condition.
- Where a backflow prevention device is installed on a water system, a device for controlling pressure due to thermal expansion must be installed.
- **Do not use** a torch or other high temperature sources near filtration system, cartridges, plastic fittings or plastic plumbing.
- On plastic fittings, never use pipe sealant or pipe dope. Use PTFE thread tape only, pipe dope properties may deteriorate plastic.
- Take care when using pliers or pipe wrenches to tighten plastic fittings, as damage may occur if over tightening occurs.
- Do not install in direct sunlight or outdoors.
- Do not install near water pipes which will be in path of a drilling tool when selecting the position to mount the bracket.
- Mount filter in such a position as to prevent it from being struck by other items used in the area of installation.
- Ensure that the location and fasteners will support the weight of the system when installed and full of water.
- Ensure all tubing and fittings are secure and free of leaks.
- Do not install unit if collet is missing. Contact 3M Purification Inc. if collets are missing from any fittings.
- SHUT OFF FUEL OR ELECTRIC POWER SUPPLY TO WATER HEATER after water is shut off.
- All hydro-pneumatic pressurized tanks must have an appropriate pressure relief valve installed.
- The Pre and Post filter cartridges **MUST** be replaced every 12 months, at the rated capacity or sooner if a noticeable reduction in flow rate occurs.
- The RO Membrane **MUST** be replaced every 24 months, at the rated capacity or sooner if a noticeable reduction in flow rate occurs.

## IMPORTANT NOTES

- Failure to follow installation, operation and maintenance instructions may result in leakage and will void warranty.
- Allow minimum of 6” (20 cm) clear space under the assembly to facilitate cartridge changes.
- Install with inlet, outlet, tank and reject ports as labeled. Make sure not to reverse connections.

## Preface

The TFS450 reverse osmosis filtration system requires three elements for most applications.

1. **Potable inlet water with an average supply pressure of at least 70 psi (483 kPa).** This is necessary in order to achieve the TFS450 daily production rating of 300 gallons per day at 70 psi (483 kPa) and 77°F (25°C) without blending. (See Figure 1). If the inlet supply pressure average is less, it is recommended to install the TFS450-BP Water Booster Pump (Part Number [62339-01](#)). (Sold Separately)
2. **The TFS450 reverse osmosis (RO) filtration system** with two RO membrane cartridges and head assemblies bracketed for a pre-filter (required) and a final (post) filter (required for beverage applications). The System includes a precision blending valve that allows adjustment of the mineral content of the product water from 10% (with no blending) to about 50% of the mineral content of the inlet water. A battery powered built-in TDS (Total Dissolved Solids) meter provides monitoring of the product water. A pressure regulator opens a bypass line and thus maintains continuous flow to downstream equipment at times of high demand. All product waters (RO water, blended water, and bypass water) are filtered only when final (post) filter is used.
3. **A pressurized external storage tank** with sufficient draw-down to maintain the short-term volume and flow requirements of all downstream equipment if operated simultaneously. For most foodservice applications, the recommended draw-down tank volumes are either 10 gallons (37.8 liters), 20 gallons (75.7 liters) or 40 gallons (151.4 liters). (Tanks sold separately)

This manual includes instructions for the installation, Cartridge Change Procedure, and Troubleshooting of the three elements.

## Cartridge Change Procedure

## CAUTION

### To reduce the risk associated with property damage due to water leakage:

- The pre and post filter cartridges **MUST** be replaced every 12 months, at the rated capacity or sooner if a noticeable reduction in flow rate occurs.
- The RO membrane **MUST** be replaced every 24 months, at the rated capacity or sooner if a noticeable reduction in flow rate occurs.

### De-Pressurization Process

1. Turn off the inlet water valve.
2. Close the tank valve.
3. Open the tank sample valve and the outlet sample valve.
4. Wait until water flow from each sample valve stops. Check the post filter pressure gage. Gage should read 0 psi. The system is now de-pressurized.

**IMPORTANT NOTE:** The tank will still be under pressure.

### Pre-filter Cartridge Replacement Procedure

1. De-pressurize the system, as instructed above.
2. To remove the pre-filter, press the yellow tab and turn the cartridge to the left ¼ turn. Pull down to remove and discard it.
3. Insert a new filter by aligning the tabs with the filter head. Push up to insert and turn to the right ¼ turn.

**IMPORTANT NOTE:** After installation, the first 10 gallons (38 liters) of product water should be discarded through the tank sample valve to properly flush the new filter.

### Final (Post) Filter Cartridge Replacement

1. De-pressurize the system, as instructed above.
2. To remove the final (post) filter, press the yellow tab and turn to the left (counterclockwise) ¼ turn. Pull down to remove and discard filter.
3. Insert a new filter by aligning the tabs with the filter head. Push up to insert and turn to the right (clockwise) ¼ turn.

**IMPORTANT NOTE:** After installation, the first 10 gallons (38 liters) of product water should be discarded through the outlet sample valve to properly flush the new filter.

### RO Membrane Replacement Procedure

1. It is recommended that these two cartridges be changed one at a time so that the reject tubing on the bottom is connected properly and in the same location. Proper performance of the TFS450 system depends upon the correct connections of reject-line tubing from each of the two RO membranes.
2. De-pressurize the system as instructed above.
3. Remove the left RO membrane first. Rotate the filter ¼ turn to the left and pull down to disconnect the cartridge from the head.
4. Disconnect the reject tubing by pushing in and holding the white collet on the plastic fitting on the **bottom** of the filter cartridge to release the tubing.

**IMPORTANT NOTE:** Do not disconnect the opposite end of this tubing from the system. **It should remain connected to the inlet of the right-hand housing.** Discard the used cartridge.

5. Remove the white plug from the plastic fitting on the new cartridge and connect the reject tubing.
6. Insert the new cartridge by aligning the tabs with the filter head. Push up to insert and turn to the right ¼ turn.
7. Repeat the same procedure for RO membrane on the right side. The opposite end of the reject tubing from the system, in this case, will be connected into the flow control and permeate pump.

**IMPORTANT NOTE:** The first full tank of water filtered after replacing the RO membrane should be discarded, as it was with the system start-up.

### Restarting and Purging the TFS450 System

1. Close the tank and outlet shut-off valves.
2. If you have booster pump, plug in. Open the outlet sample valve.
3. Open the inlet water shut-off valve.
4. Wait for a steady stream of water from the sample valve. This will purge air from the system.
5. Close the sample valve and check for leaks.
6. Open the tank and outlet shut-off valves.

Fill Times for TFS450 Tanks*	
Tank Drawdown Volume	Approximate Time to Fill
10 gallons (37.8 liters)	0.8 hours
20 gallons (75.7 liters)	1.6 hours
40 gallons (151 liters)	3.2 hours

\*@70°F (21°C) Water Temperature

### Adjustment of TDS (Total Dissolved Solids) Using the Blending Valve

#### IMPORTANT NOTES:

- Typical TDS (Total Dissolved Solids) values for coffee are 80-200 ppm and occasionally lower for espresso, depending upon taste preference.
- The blending valve should be set at start-up and checked periodically, for example when changing filter cartridges. The valve is a precision metering valve that may be locked using a small allen wrench.
- In order to set the blending valve, it is important that no bypass water be mixed with the blended RO water. Thus, the TDS of the blended water must be measured from a sample taken from the tank or from the line going to the tank while the valve is being adjusted. Use the sample valve at the tank to collect the samples. The TDS of the sample must be measured using a TDS meter (not supplied). The TDS meter on the TFS450 RO filtration system may not be used to set the blending valve. The meter will read the TDS of water exiting the system, and this is not always blended RO water.

1. Close the outlet shut-off valve to downstream equipment and the tank shut-off valve and open the sample valve at the tank.
2. After about two (2) minutes, collect a sample and measure the TDS using a TDS meter (not supplied).
3. Rotate the blending valve to the left (counterclockwise) to increase the product water TDS and to the right (clockwise) to decrease the product water TDS. The valve should be opened intermittently at 1.0 to 1.5 turns at a time. Check the TDS after each incremental opening and again two (2) minutes after the desired TDS value is reached. Re-adjust and check, as needed.
4. Lock the blending valve using a 0.05 inch allen wrench.
5. Close the tank sample valve, open the tank shut-off valve and open outlet valve.

**IMPORTANT NOTE:** The TDS Meter is push-button operated and requires two (2) 357A batteries.

### Automatic Bypass Pressure Adjustment

When the pressure in the remote storage tank falls below the bypass pressure set on the pressure regulator, the automatic bypass will begin to open to allow a flow of filtered water to maintain the product water demand flow. The bypass pressure setting should be checked and adjusted if necessary at system start-up and periodically when the filter cartridges are changed. The regulator is shipped in the "closed" position and must be set to 30 psi (207 kPa) prior to system start-up. The setting should be checked and adjusted periodically, for example when the filter cartridges are changed.

**IMPORTANT NOTE:** Do not set bypass pressure greater than 30 psi (207 kPa).

1. Close the shut-off to the outlet to downstream equipment and the tank shut-off valve.
2. Open the tank sample ball valve and direct the flow to drain or to a collection vessel. This step relieves outlet pressure supplied by the RO membranes and the blended water being produced.
3. Adjust the pressure to 30 psi (207 kPa) as seen on the final (post) filter pressure gauge (on the right side of the filtration system). Rotating to the right (clockwise) increases the pressure setting. Rotating to the left (counterclockwise) decreases the pressure setting. At start-up, this step may require several revolutions.
4. Relieve pressure using the sample valve on the outlet to decrease gauge reading. Note the pressure and re-adjust the regulator, as necessary.
5. Tighten the lock nut to secure the pressure regulator.
6. Open outlet valve. Close both sample valves and open the tank shut-off valve.
7. The tank will now begin to fill with RO water. The necessary times to fill tanks of various drawdown volumes are given in the table above. Allow the system to run until the tank is full and you can no longer hear the permeate pump clicking. The first tank of water should be sent to drain to properly flush the RO System. The tank may be drained by opening the tank sample valve and directing the flow to drain. (The tank may also be drained by opening the outlet sample valve and directing the flow to drain. Using the outlet sample valve further serves to properly flush the final (post) filter cartridges.)
8. System is now ready to use

### TFS450 System Overview

Module/Element	Part Number	3M ID
TFS450-BP Water Booster Pump Module (Sold Separately)	62339-01	
TFS450 RO Filtration System with Pre- and Post Filters Included	56239-01	70-0202-1775-1
TFS450 RO Filtration System without Pre and Post Filters and Bypass Plug in Final Filter Head	56230-02	70-0202-1776-9
Tank 20-Gallon Draw-Down (Sold Separately)	55984-08	
Tank 40-Gallon Draw-Down (Sold Separately)	55984-09	

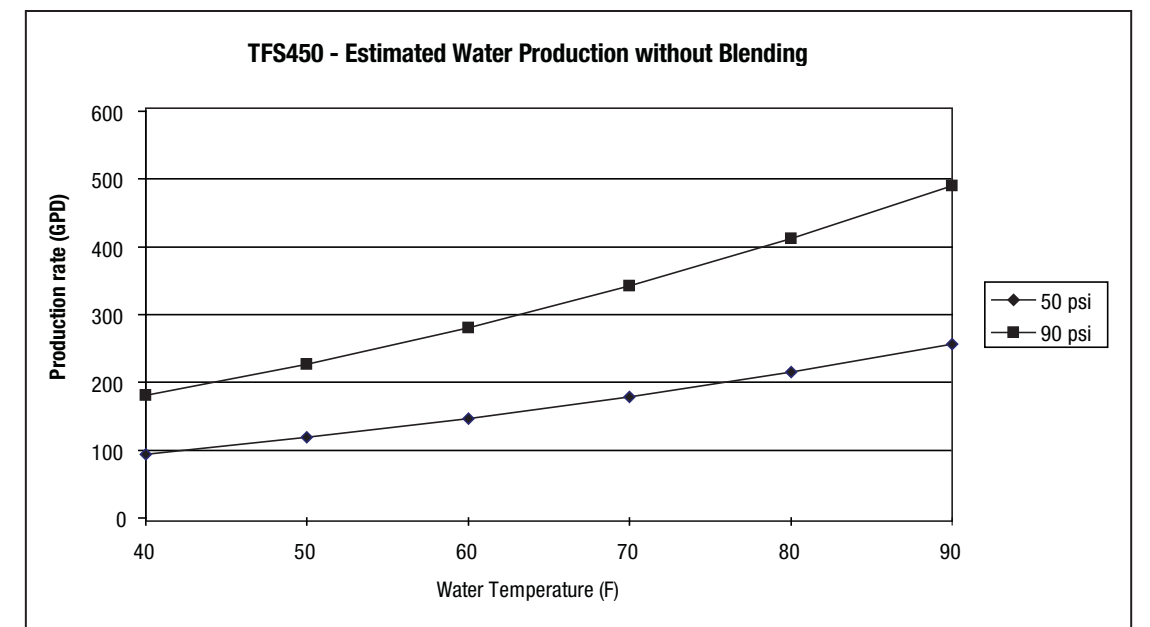

Figure 1

### Parts List

The following parts are included with the TFS450 reverse osmosis filtration system. Unpack the contents from the product box and check to verify that all of the parts are included. Should any parts be missing, please contact 3M Purification at 866.990.9785.

Description	56239-01 (Qty)	56239-02 (Qty)
Base unit assembly (see Figure 2)	1	1
Pre-filter Cartridge HF95	1	0
Final (Post) Filter Cartridge HF90	1	0
Final (Post) Filter Bypass Plug	0	1
RO Membrane Cartridge	2	2
TDS meter	1	1
Installation Manual	1	1

## TFS450 RO Filtration System

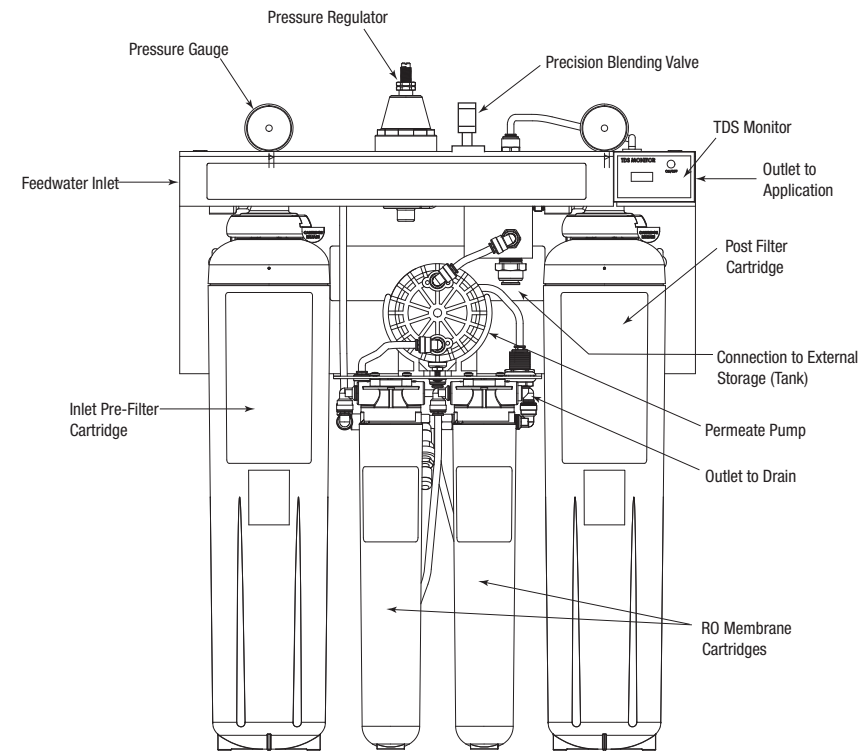

TFS450 RO Filtration System

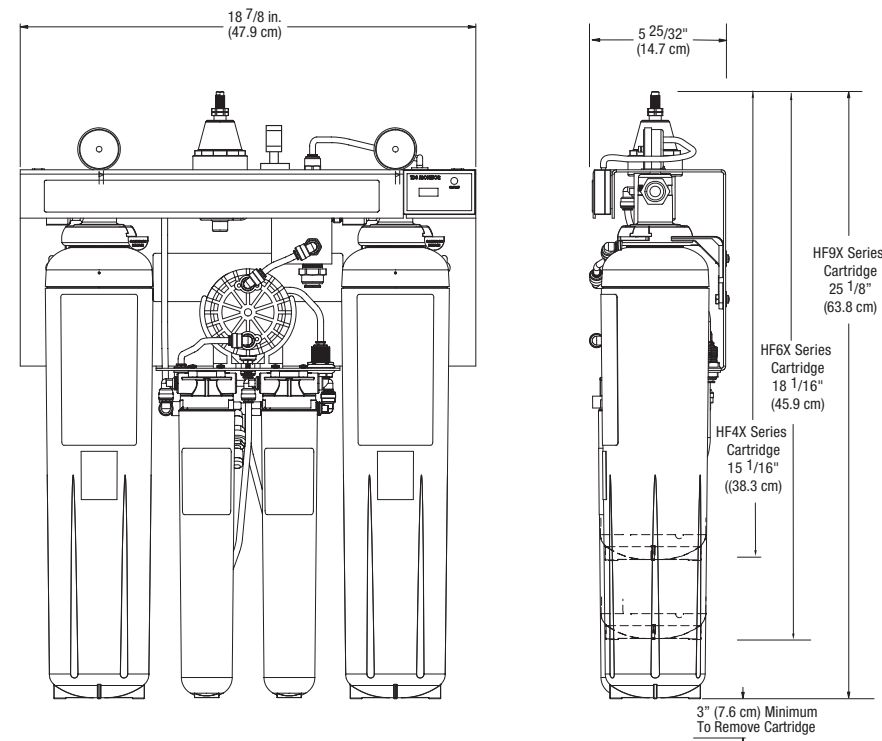

TFS450 RO Filtration System Dimensions

Figure 2

## Final (Post) Filter Cartridge

The final (post) filter cartridge reduces possible off characteristics from the system and the storage tank and provides cyst-rated filtration of all product water, including by-pass and blending water. For steamer operation, a final (post) filter may not be required. Thus, a by-pass plug is available. Choices of cyst-rated final (post) filters are listed in the table below. Choose a final (post) filter according to the maximum possible demand flow rate when all downstream equipment is operating simultaneously. The TFS450 RO filtration system supplied with both pre-filter and final (post) filter includes the HF-90 final (post) filter cartridge listed in the table.

Part Number	Description	Chlorine Taste and Odor Capacity		Maximum Flow Rate	
		Gpm	Lpm	Gal	Liters
56151-01	HF20	1.5	5.7	9,000	34,100
56151-05	HF30	1.67	6.3	14,000	53,000
56133-03	HF40	2.1	7.9	25,000	94,600
56134-03	HF60	3.34	12.6	35,000	132,500
56135-03	HF90	5.0	18.9	54,000	204,200
62147-03	Bypass Plug	-	-	-	-

- Remove the red cap from the (post) filter cartridge.
- Align the tabs on the cartridge to the openings in the final (post) filter head on the far right side of the TFS450 RO filtration system and push up to insert the filter.
- Turn the final (post) filter ¼ turn to the right until a click is heard, indicating that the filter is properly seated.

## Reverse Osmosis Cartridges (2)

The two (2) RO membrane filter cartridges are identical. The drain lines to the bottom of each must be assembled properly or the system will not perform properly.

- Install the left side cartridge first. Align the tabs and turn ¼ turn to the right to secure the cartridge into the head. Remove the white plug from the bottom port and insert the reject tubing labeled "LEFT".
- Install the second cartridge into the right-side head using the same procedure. Remove the white plug from the bottom port and insert the tubing labeled "RIGHT".

**IMPORTANT NOTE:** Double check the fittings into the positions labeled "LEFT" and "RIGHT". Proper operation of the system depends upon the correct installation of these two connections.

## Start-Up Procedure

At startup, the procedures outlined below must be completed in the sequence:

- Measure and Adjust tank Air Charge
- Adjustment of TDS (Total Dissolved Solids) by Setting the Blending Valve
- Automatic Bypass Pressure Adjustment

## Tank Air Charge Adjustment

**IMPORTANT NOTE:** Improper tank precharge pressure will impact system water production. The tank precharge pressure must be adjusted at start-up. Tank precharge pressure must be then be adjusted annually.

**IMPORTANT NOTE:** The tank is empty as supplied. If measuring and adjusting the tank pressure after start-up, be sure the tank is empty.

- If you have booster pump, unplug. Close the inlet water shut-off valve and the outlet (product) water shut-off valve.
- Open the tank shut-off valve and drain the tank. If conducting the re-adjustment after start-up, the tank may be emptied through either the tank sample valve or the sample valve on the outlet line. Leave one or both of these open during the measurement and adjustment.
- Locate the Schrader Air Valve on the tank. Using a standard bicycle or automobile pressure gauge that is capable of reading pressure accurately from 0-40 psi (0-276 kPa), connect the air pressure gauge to the Schrader Air Valve and read the tank's air pressure.
- The pressure as shipped is about 26 psi (179 kPa). The air pressure for proper system operation should be 28-32 psi (193-221 kPa). If the air pressure is below 28 psi (193 kPa) or above 32 psi (221 kPa), complete the following steps.
  - Using a standard bicycle pump, add or release air pressure in the tank.
  - Repeat until the pressure is 28-32 psi (193-221 kPa).
- Close the tank sample valve and the sample valve on the outlet line. Open inlet and outlet valves. If you have booster pump, plug in. Allow sufficient time for the tank to refill before operating equipment. Approximate tank fill times are given in the table on next page.

## How To Use “Push-In” Fittings (Collet)

### CAUTION

#### To reduce the risk associated with property damage due to water leakage:

- Ensure all tubing and fittings are secure and free of leaks.
- Do not install unit if collet is missing. Contact 3M Purification if collets are missing from any fittings.

This product is outfitted with user friendly Push-In connectors. Proper use of the connectors is shown in Figure 4. It is most important that the tubing selected for use with these connectors be of high quality, exact size and roundness, and with no surface nicks or scratches. If it is necessary to cut the tubing, use a plastic tubing cutter or sharp razor knife. Make a clean square cut. Should a leak occur at a Push-In connector, the cause is usually defective tubing.

- To Fix:**
1. Relieve pressure
  2. Release tubing
  3. Cut off at least 1/4” from end
  4. Reattach tubing
  5. Confirm connection is leak free

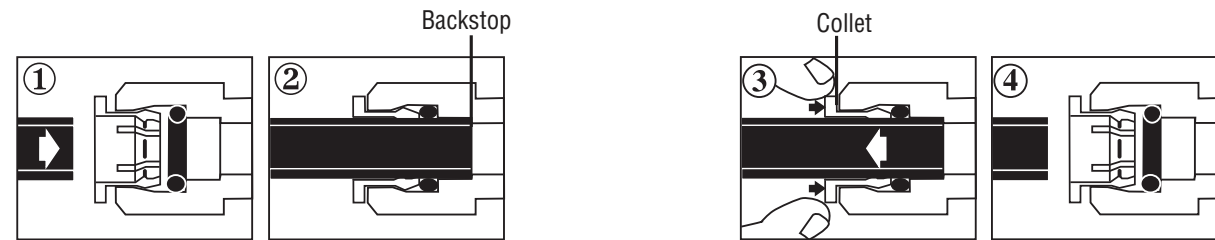

**To Attach Tubing**  
Push tubing in as far as it will go. Tubing must be inserted past o-ring and hit backstop. Pull tube to ensure it is secured.

**To Release Tubing**  
Push in collet to release tubing. With collet held, pull tubing straight out.

Figure 4

## Installation of Filter Cartridges

### Pre-filter Cartridge

A pre-filter cartridge that reduces chlorine from the feed water is required for proper operation of the TFS450 RO filtration system. If installing the TFS450 RO filtration system without a pre-filter, pre-filter choices are listed in the table below. Select a pre-filter that matches the anticipated maximum water volume that will be processed in no less than twelve months. The pre-filter must be removed and replaced at that time. The TFS450 RO filtration system supplied with both pre-filter and final (post) filter includes the HF-95 pre-filter cartridge listed in the table.

Part Number	Description	Chlorine Taste and Odor Capacity		Maximum Service Flow Rate	
		Gallons	Liters	Gpm	Lpm
56152-27	HF27 GAC	4,800	18,200	1.5	5.7
56152-37	HF37 GAC	5,500	20,800	1.67	6.3
56152-21	HF25 Block	10,000	37,500	1.5	5.7
56152-05	HF35 Block	12,600	47,700	1.67	6.3
56133-07	HF45 Block	25,000	94,600	2.1	7.9
56134-07	HF65 Block	35,000	132,500	3.34	12.6
56135-07	HF95 Block	54,000	202,400	5.0	18.9

- Remove the red cap from the pre-filter cartridge.
- Align the tabs on the cartridge to the openings in the pre-filter head on the left side of the filtration system and push up to insert the filter.
- Turn the pre-filter ¼ turn to the right until a click is heard, indicating that the filter is properly seated.

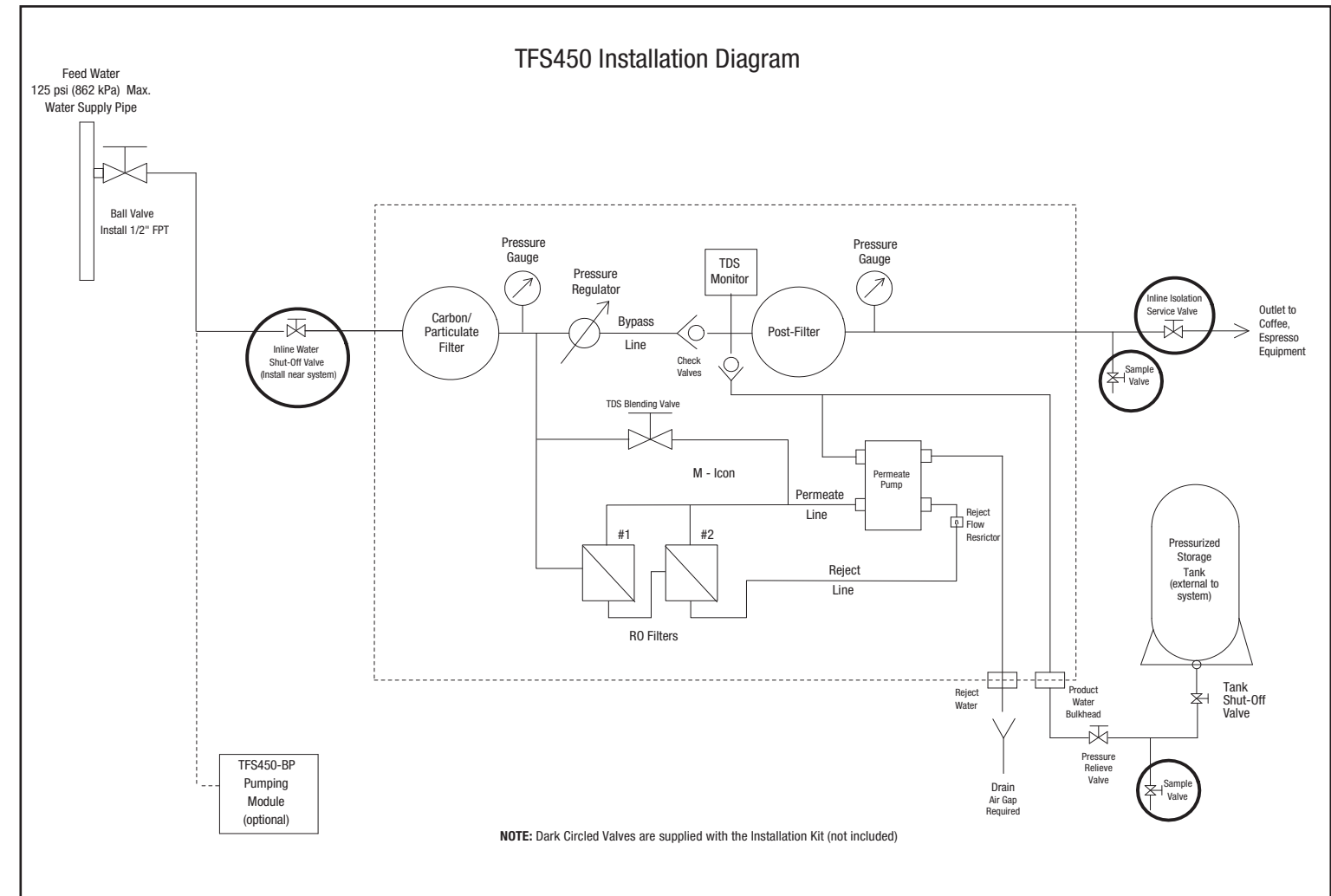

Figure 3  
TFS450 Plumbing Diagram

### Installation Kit (Part Number 50913-01)

The installation kit is sold separately. It includes inlet water and outlet water shut-off valves, two sample flush valve kits – one for the product water to downstream equipment and the second for installation on the tank line – and 15 ft (4.6 m) of ½” (OD) tubing to connect the membrane module to the external storage tank. If the kit is not purchased, these components must be provided by the installer.

## Feedwater Parameters

### CAUTION

To reduce the risk associated with property damage due to water leakage:

- **Read and follow** Use Instructions before installation and use of this system.
- Installation and use **MUST** comply with all state and local plumbing codes.
- Before installation, shut-off main water supply and depressurize and drain pipes.
- **Do not install** systems in areas where ambient temperatures may go above 110° F (43.3° C).
- **Do not install** on hot water supply lines. The maximum operating water temperature of this filtration system is 100°F (37.8°C).
- **Do not install** if water pressure exceeds 100 psi (689 kPa). If your water pressure exceeds 80 psi (552 kPa), you must install a pressure limiting valve. Contact a plumbing professional if you are uncertain how to check your water pressure.
- **Do not install** where water hammer conditions may occur. If water hammer conditions exist you must install a water hammer arrester. Contact a plumbing professional if you are uncertain how to check for this condition.

**IMPORTANT NOTE:** Be sure to confirm that the feedwater falls within the limits shown below. If unsure of the feedwater quality, check with your 3M distributor:

Inlet water pressure	40-100 psi (276-690 kPa)
Feed TDS (Total Dissolved Solids)	230-1400 PPM*
Hardness	< 10 grains (171 mg/L)
Iron (Fe)	< 0.1 mg/L
Hydrogen Sulfide	none allowable
Feed pH	4-11
Free chlorine	< 2 mg/L
Manganese (Mn)	< 0.05 mg/L
Turbidity	< 5 NTU

\* May be operated up to 1400 ppm water, however outlet TDS may exceed steamer requirements if over 800 ppm. If TDS is over 1400 ppm and /or hardness over 10 grains (171 mg/L), a softener is recommended.

## Equipment Set-up and Installation

### Equipment Location

Prior to installing the TFS450 RO filtration system components, carefully plan the installation location for all system components.

Obtain additional hardware for plumbing connections (as needed).

1. Position the auxiliary storage tank in the desired location.
2. The TFS450 RO filtration system should be installed within 15 ft (4.6 m) of the tank.
3. The TFS450-BP water booster pump (if installed) should be installed within 10 ft (3.05 m) of the TFS450 RO filtration system.
4. Access to feed-water and drain line connections are required.
5. All components should be accessible and have at least 6" (15 cm) of clearance on all sides to facilitate servicing.

### Mounting the TFS450-RO Filtration System

1. Locate the position of the assembly. The horizontal hole spacing is 16" (40.6 cm) center-to-center.
2. Draw a level line on the wall where bracket is to be mounted. Measure and mark locations for screws.
3. Install mounting screws (not included) into each of the hole locations. Be sure to leave ¼" (0.6 cm) space between the bottom of the screw head and the wall so that the bracket can be hung.

### CAUTION

**To reduce the risk associated with property damage due to water leakage:**

- Mount filter in such a position as to prevent it from being struck by other items used in the area of installation.
- Ensure that the location and fasteners will support the weight of the system when installed and full of water.

4. Hang the assembly from the mounting screws.
5. Once the bracket is hung, tighten the mounting screws so that the bracket is snug between the screw and the wall.

## Plumbing Connections

**1. If using the TFS450-BP water booster pump, please refer to the TFS450-BP water booster pump Owners Manual.**

**2. Inlet Side of TFS450 RO filtration system:**

- Install the ½" inlet-water shut-off valve and nipple as supplied with the installation kit on the inlet (left) side of the pre-filter head. Install ½" tubing from the inlet water source or from the TFS450-BP water booster pump to the inlet-water shut-off valve on the TFS450 RO filtration system. The fitting to the inlet water shut-off valve is ½" NPT (female).

**3. Outlet Side of TFS450 RO Filtration system and Sample Valve:**

- Install a ½" nipple and ball valve to the tee outlet and to the leg of the tee. The valve on the leg of the tee is for pressure release, flushing and sampling. Install ½" tubing from the opposite side of the tee to the downstream equipment.

**4. Reject Connection:**

- Run a ¾" tube from the reject to drain port on the TFS450 RO filtration system to the drain.

### WARNING

**To reduce the risk associated with the ingestion of contaminants:**

- An approved air gap must exist between the RO System reject drain line and the drain opening to meet plumbing codes.

## Storage Tank Connections:

**IMPORTANT NOTE:** A pressure relief valve (not included) should always be installed on the storage tank plumbing line.

A pressurized external storage tank (purchased separately) is required to achieve the short-term demand volumes and flow rates for downstream equipment. Choose the tank size to match the short-term volume requirement of all downstream equipment. Part numbers and draw down volumes for three tanks are included below.

Part Number	Drawdown Volume	
	Gallons	Liters
55984-07	10	37.8
55984-08	20	75.7
55984-09	40	151

- Check the air precharge pressure in the tank using the Schrader® valve on the tank. With the tank empty, the pressure should read slightly less than 30 psi (207 kPa). Adjust the air pressure to about 30 psi (207 kPa) using procedure on Page 11.

- Place the tank in an area where it will not be bumped or jarred.

- Using the ½" tubing from the installation kit connect one end to the product bulkhead fitting – outlet to tank on the TFS 450 RO filtration system. The tank and bulkhead fittings are each quick connect.

**IMPORTANT NOTE:** Do not connect the opposite end to the tank until after reading the following.

- It is recommended that the pressure regulator be checked and adjusted at this time and before startup. The automatic bypass delivers (non-RO) water to maintain the demand flow rate. This occurs when the pressure in the tank falls below the regulator's set point and is unable to deliver RO water. The downstream equipment will thus never be starved for product water even during periods of high demand.

- Cut the tubing at a convenient point and install the tank sample valve kit from the installation kit (½" quick-connect fittings). This valve may be used to drain the tank and to procure product water samples. Provisions to collect and/or to drain the water taken from this valve must be considered.

- Connect the remaining tubing from the sample valve to the tank.