

# 3M™ Water Filtration Products

## Installation and Operation Instructions for ScaleGard™ HP Reverse Osmosis System

(Original Instructions)

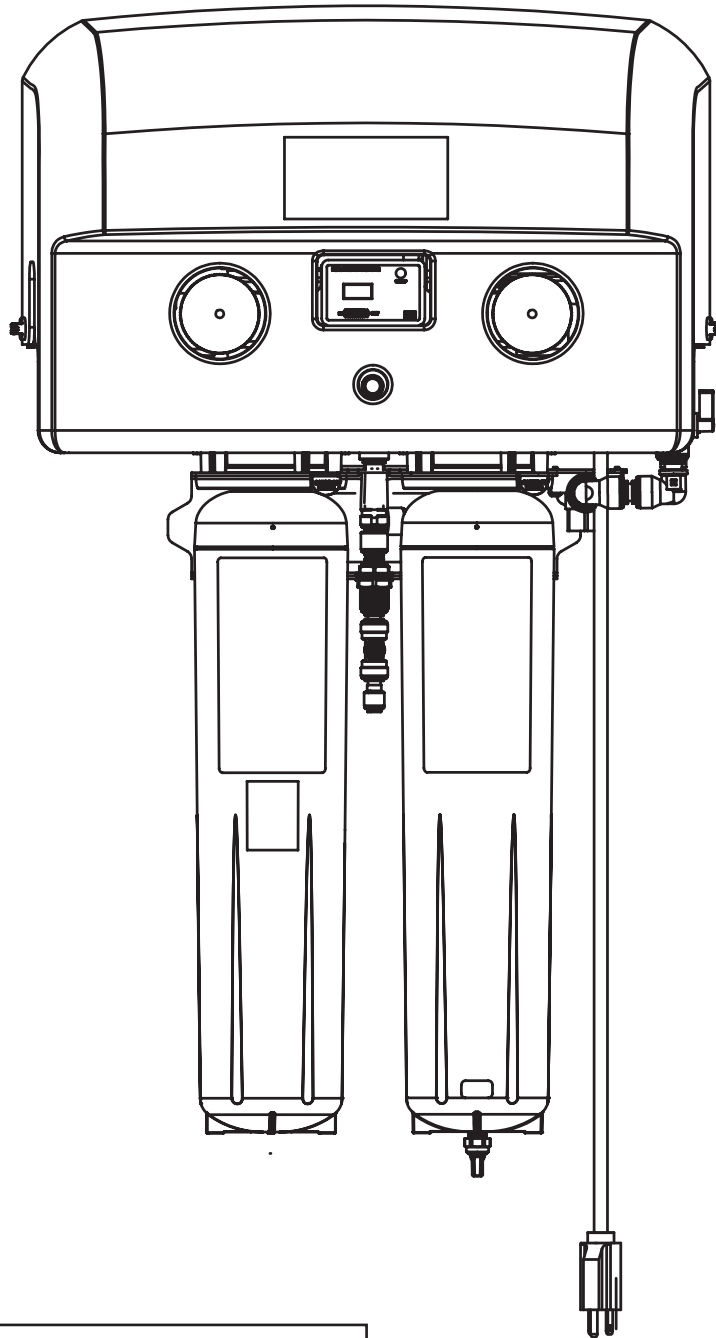

System tested and certified by NSF International against NSF/ANSI Standard 58 for material safety and the claims specified on the Performance Data Sheet and against CSA B483.1.

Installer: Please leave this manual with owner/operator.

Owner/Operator: Please retain for operation and future instructions.

# Table of Contents

---



Safety Information.....	3, 4
Parts List .....	5
Feedwater Requirements.....	6
Other Requirements .....	6
Equipment Set-Up and Installation.....	7
System Start-Up.....	10
Routine Maintenance.....	15, 16
Troubleshooting Guide.....	17
Product Replacement Parts .....	18
Limited Warranty.....	Back Cover

# SAFETY INFORMATION

Read, understand, and follow all safety information contained in these instructions prior to installation and use of the 3M™ Water Filtration Products ScaleGard™ HP reverse osmosis system. Retain these instructions for future reference.

**Intended use:**

The ScaleGard™ HP reverse osmosis system is intended for use in filtering potable water and has not been evaluated for other uses. The product is installed at the point of use and must be installed as specified in the installation instruction by a qualified professional.

<b>EXPLANATION OF SIGNAL WORD CONSEQUENCES</b>	
 <b>WARNING</b>	Indicates a potentially hazardous situation, which, if not avoided, could result in death or serious injury and/or property damage.
 <b>CAUTION</b>	Indicates a potentially hazardous situation which, if not avoided, may result in minor or moderate injury and/or property damage.
<b>NOTICE</b>	Indicates a potentially hazardous situation, which, if not avoided, may result in property damage.

 <b>WARNING</b>
<p><b>Read entire manual. Failure to follow all guides and rules could cause personal injury or property damage.</b></p> <ul style="list-style-type: none"> <li>• Check with your local public works department for plumbing codes. You must follow their guidelines as you install the water filtration system.</li> <li>• Your water filtration system will withstand up to 125 pounds per square inch (psi) water pressure.</li> <li>• An approved 20 gallon or 40 gallon tank must be used.</li> <li>• An approved post filter is recommended.</li> </ul>
<p><b>To reduce the risk associated with choking:</b></p> <ul style="list-style-type: none"> <li>• DO NOT allow children under 3 years of age to have access to small parts during the installation of this product.</li> </ul>
<p><b>To reduce the risk of serious injury associated with the potential ingestion of chemicals or contaminants:</b></p> <ul style="list-style-type: none"> <li>• Do not use with water that is microbiologically unsafe or of unknown quality without adequate disinfection before or after the system.</li> <li>• Flush RO Cartridge: Before use, you must flush the RO cartridge as specified in the installation instructions, and discard any water generated until flush is complete. Failure to do so could cause serious injury from exposure to chemicals that can be extracted from the RO membrane during this initial flush.</li> <li>• Sanitize and Flush Tank: Before use, you must sanitize and flush the hold tank as specified. Sanitizing the hold tank minimizes the risk for exposure to contaminants. Failure to flush the hold tank with water after sanitizing could cause serious injury from exposure to sanitizer present.</li> </ul>
<p><b>To reduce the risk associated with hazardous voltage due to an installer drilling through existing electric wiring or water pipes in the area of installation:</b></p> <ul style="list-style-type: none"> <li>• DO NOT install near electric wiring or piping which may be in path of a drilling tool when selecting the position to mount the filter bracket.</li> </ul>
<p><b>To reduce the risk associated with back strain:</b></p> <ul style="list-style-type: none"> <li>• Follow safe lifting procedures.</li> </ul>
<p><b>To reduce the risk of physical injury:</b></p> <ul style="list-style-type: none"> <li>• All hydro-pneumatic pressurized tanks MUST have an appropriate pressure relief valve installed. Pressure relief valve must be maintained and inspected every 6 months. Contact a plumbing professional if you are uncertain how to select/install/maintain a pressure relief valve.</li> </ul>
<p><b>To reduce the risk of injury associated with household bleach:</b></p> <ul style="list-style-type: none"> <li>• READ and follow manufacturer's directions and cautions.</li> <li>• KEEP OUT of the reach of children.</li> <li>• DO NOT intermix with other chemicals.</li> <li>• WEAR appropriate Personal Protection Equipment (PPE)</li> </ul>
<p><b>To reduce the risk associated with ingestion of water contaminated with sanitizer:</b></p> <ul style="list-style-type: none"> <li>• After installation and after sanitizing the hold tank, sanitizers must be flushed from the system before first use as directed within the installation instructions.</li> <li>• Failure to flush the hold tank with water after sanitizing could cause serious injury from exposure to sanitizer present.</li> </ul>

 <b>CAUTION</b>
<p><b>To reduce the risks associated with environmental contamination which, if not avoided, could result in minor or moderate injury:</b></p> <ul style="list-style-type: none"> <li>• At the end of useable life, dispose of this system in accordance with applicable local regulations or laws.</li> </ul>
<p><b>To reduce the risks associated with impact which, if not avoided, could result in minor or moderate injury:</b></p> <ul style="list-style-type: none"> <li>• Depressurize system as shown in manual prior to cartridge removal.</li> </ul>
<p><b>To reduce the risks associated with heavy objects which, if not avoided, could result in minor or moderate injury:</b></p> <ul style="list-style-type: none"> <li>• Follow safe lifting procedures.</li> </ul>

**IF CONNECTION IS MADE TO A POTABLE WATER SYSTEM, THE SYSTEM SHALL BE PROTECTED AGAINST BACKFLOW.**

**NOTICE**

**To reduce the risk associated with property damage due to water leakage or flooding:**

- Read and follow Use Instructions before installation and use of this system.
- The pre-filter and post filter cartridges **MUST** be changed every 12 months, or sooner if the rated capacity is achieved or a noticeable reduction in flow rate occurs.
- The RO membrane cartridge **MUST** be changed every 24 months, or sooner if a noticeable decrease in flow or TDS reduction occurs.
- Failure to replace the filters and RO membrane cartridges at recommended intervals may lead to reduced filter performance and failure of the filters, causing property damage from water leakage or flooding.
- Installation and use **MUST** comply with all state and local plumbing codes.
- Protect from freezing, remove all cartridges when temperatures are expected to drop below 40°F (4.4°C).
- **DO NOT** install systems in areas where ambient temperatures may go above 100°F (37.8°C).
- **DO NOT** install on hot water supply lines. The maximum operating water temperature of this filter system is 100°F (37.8°C).
- **DO NOT** install if water pressure exceeds 125 psi (862 kPa). Contact a plumbing professional if you are uncertain how to check your water pressure.
- **DO NOT** install where water hammer conditions may occur. If water hammer conditions exist you must install a water hammer arrester. Contact a plumbing professional if you are uncertain how to check for this condition.
- Where a backflow prevention device is installed on a water system, a device for controlling pressure due to thermal expansion **MUST** be installed. Contact a plumbing professional if you are uncertain how to select/install/maintain a thermal expansion device.
- Where a booster pump is installed on the feed water inlet line, you **MUST** maintain and inspect the attached pressure switch regularly in accordance with the booster pump manufacturer's instructions. Contact a plumbing professional if you are uncertain how to maintain your booster pump system.
- Where a booster pump is installed on the feed water inlet line, you **MUST** install an appropriate pressure relief valve. Pressure relief valve must be maintained and inspected every 6 months. Contact a plumbing professional if you are uncertain how select/install/maintain a pressure relief valve.
- **DO NOT** install in direct sunlight or outdoors.
- **DO NOT** install near water pipes which will be in path of a drilling tool when selecting the position to mount the bracket.
- Mount RO system in such a position as to prevent it from being struck by other items used in the area of installation.
- Ensure that the location and fasteners will support the weight of the system when installed and full of water.
- Ensure all tubing and fittings are secure and free of leaks.
- **DO NOT** install unit if collet is missing. Contact 1-866-990-9785 if collets are missing from any fittings.
- Use compatible flexible tubing with 'push in connections' (such as PEX tubing, PE tubing, PP tubing).
- **DO NOT** install with rigid piping (such as copper, aluminum, stainless steel, chrome plated, or anodized tubing).
- All hydro-pneumatic pressurized tanks **MUST** have an appropriate pressure relief valve installed. Pressure relief valve must be maintained and inspected every 6 months. Contact a plumbing professional if you are uncertain how to select/install/maintain a pressure relief valve.

**IMPORTANT NOTES**

- Failure to follow instructions will void warranty.
- Allow a minimum of 3" (6.72 cm) clear space under filter to facilitate cartridge change.
- Install with the inlet and outlet ports as labeled. Make sure not to reverse connections.
- Some local codes may require the use of a licensed plumber or certified installer when disrupting a potable water line.
- This appliance can be used by children aged from 8 years and above and persons with reduced physical, sensory, or mental capabilities or lack of experience and knowledge if they have been given supervision or instruction concerning use of the appliance in a safe way and understand the hazards involved.
- Children shall not play with the appliance.
- Cleaning and user maintenance shall not be made by children without supervision.
- For cold water use only.

# Parts List

The following parts comprise the ScaleGard™ HP Reverse Osmosis System. Please unpack the contents from the product box and check to verify that all of the parts listed below are included. Should any parts be missing, please contact 3M Purification Inc. at 1-866-990-9785.

Description	Quantity	Part Number
ScaleGard™ HP Reverse Osmosis System	1	<a href="#">5629101</a> (110-120VAC with Pre-filter and RO)
		<a href="#">6239301</a> (110-120VAC w/out Pre-filter and RO)
		<a href="#">6239302</a> (220-240VAC w/out Pre-filter and RO)
<a href="#">HF90-CL-RO</a> (Pre-Filter)	1	<a href="#">5613529</a>
HFRO 500 (RO membrane)	1	<a href="#">5626903</a>

## Sold Separately

Description	Quantity	Part Number
<a href="#">BEV140/BEV160/BEV190</a> Post Filter (Recommended/Sold Separately)	1	<a href="#">5616201/5616301/5616401</a>
20 Gallon Pressure Tank (Required/Sold Separately)	1	<a href="#">5598408</a>
40 Gallon Pressure Tank (Required/Sold Separately)	1	<a href="#">5598409</a>

## Equipment Components Sold Separately

Description	Quantity	Part Number
Install Kit (Sold Separately)	1	<a href="#">6841441</a>
SGHP Pre-Expansion Assembly Manifold	1	<a href="#">6235205</a>
SGHP RO-Expansion Assembly Manifold	1	<a href="#">6232705</a>
HFRO 700 (RO Membrane)	1	<a href="#">5626904</a>
HFRO 33% Recovery Kit	1	<a href="#">50-93201</a>

# Feedwater Requirements

## NOTICE

See safety information regarding reducing the risk associated with property damage due to water leakage or flooding on page 4 prior to set-up and installation of the system.

## IMPORTANT NOTES

- Be sure to confirm that the feedwater falls within the limits shown below. If unsure of the feedwater quality, check with your 3M™ Water Filtration Products distributor.

Inlet water pressure .....	30-125 psi (207-862 kPa)
Feed TDS .....	1,000 ppm Maximum
Hardness.....	<10 grains (171 mg/l)
Iron (Fe) .....	<0.1 mg/l
Hydrogen Sulfide.....	None Allowed
Feed pH .....	4-11
Free Chlorine.....	<0.1 mg/l
Manganese (Mn) .....	<0.05 mg/l
Turbidity .....	<5 NTU
Temperature.....	>50°F*

\*If at any time during the year water temperature falls below 50 °F, see challenge water recommendations below.

## Challenge Water Recommendations (Contact dealer/distributor for assistance in water testing)

If there is iron or manganese above recommended limits present in the incoming water, it is recommended to install water softening system upstream of ScaleGard™ HP System.

If incoming water hardness is greater than 10 grains (171 mg/l), it is recommended to install water softening system upstream.

If the particle count is >1000 counts/ml for particles less than 2 micron size or turbidity is greater than the recommended 5 NTU limit, then additional pre-filtration may be required. Contact your dealer/distributor for details.

### It is recommended to install an SGHP RO-EXP and SGHP Pre-EXP under the following conditions:

1. If more production capacity is needed.
2. If installed in a location where water temperature drops below 50°F (10°C) during any part of the year.
3. If the particle count is >1000 counts/ml for particles less than 2 micron size or turbidity is greater than 5 NTU limit.
4. If the incoming water TDS is greater than 1000 ppm limit.

## Other Requirements

Power..... 110V (PN-5629101, 6239301), 220V (PN-6239302)

# Equipment Set-Up and Installation

## NOTICE

See safety information regarding reducing the risk associated with property damage due to water leakage or flooding on page 4 prior to set-up and installation of the system.

### Equipment Location

Prior to installing the ScaleGard™ HP Reverse Osmosis System, carefully plan the installation location for all system components.

Position the ScaleGard HP reverse osmosis base unit and the pressure tank in desired locations as per (Figure 1).

1. Access to feedwater, drain line connections and electrical outlet is required.
2. The ScaleGard HP System must be accessible and have at least 3 inches (7.6 cm) clearance on all sides of the system to facilitate servicing. An additional 10 inches (25.4 cm) will be needed on both sides of the ScaleGard HP system to allow for the future installation of the SGHP Pre-EXP or the SGHP RO-EXP manifolds.
3. The pressure tank should be installed within 15 ft (4.6 m) of the ScaleGard HP reverse osmosis base unit and 0.5" or larger tubing diameter is required to complete installation.

Figure 1 — Plumbing Diagram

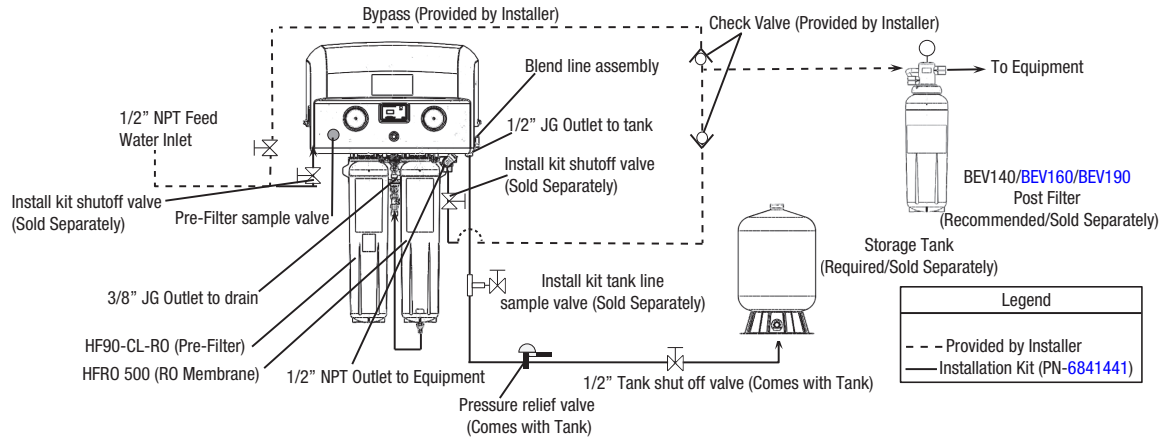

## Wall Mounting the ScaleGard™ HP Base Unit (Mounting Template included with unit)

1. Draw a level line on the wall where the bracket is to be mounted. Hold bracket key holes on level line and mark locations for screws.
2. Install mounting screws (not included) into each of the initial key holes as shown in figure 2. Be sure to leave 1/8" to 1/4" (0.3 to 0.6 cm) space between the bottom of the screw head and the wall so that the bracket can be hung. (assume system weight of 57 lbs. (25.9 kg))

### NOTICE

**To reduce the risk associated with property damage due to water leakage or flooding:**

- Mount ScaleGard™ HP base unit in such position as to prevent it from being struck by other items being used in the area of installation. Ensure that the location and fasteners will support the weight of the system when installed.

### IMPORTANT NOTES

- Allow a minimum of 3" (7.6 cm) clear space under filter to facilitate cartridge change.

3. Hang manifold from the mounting screws.
4. Once the bracket is hung, tighten the mounting screws so that the bracket is snug between the screw and the wall.
5. Install remaining mounting screws in locations as shown in figure 2.

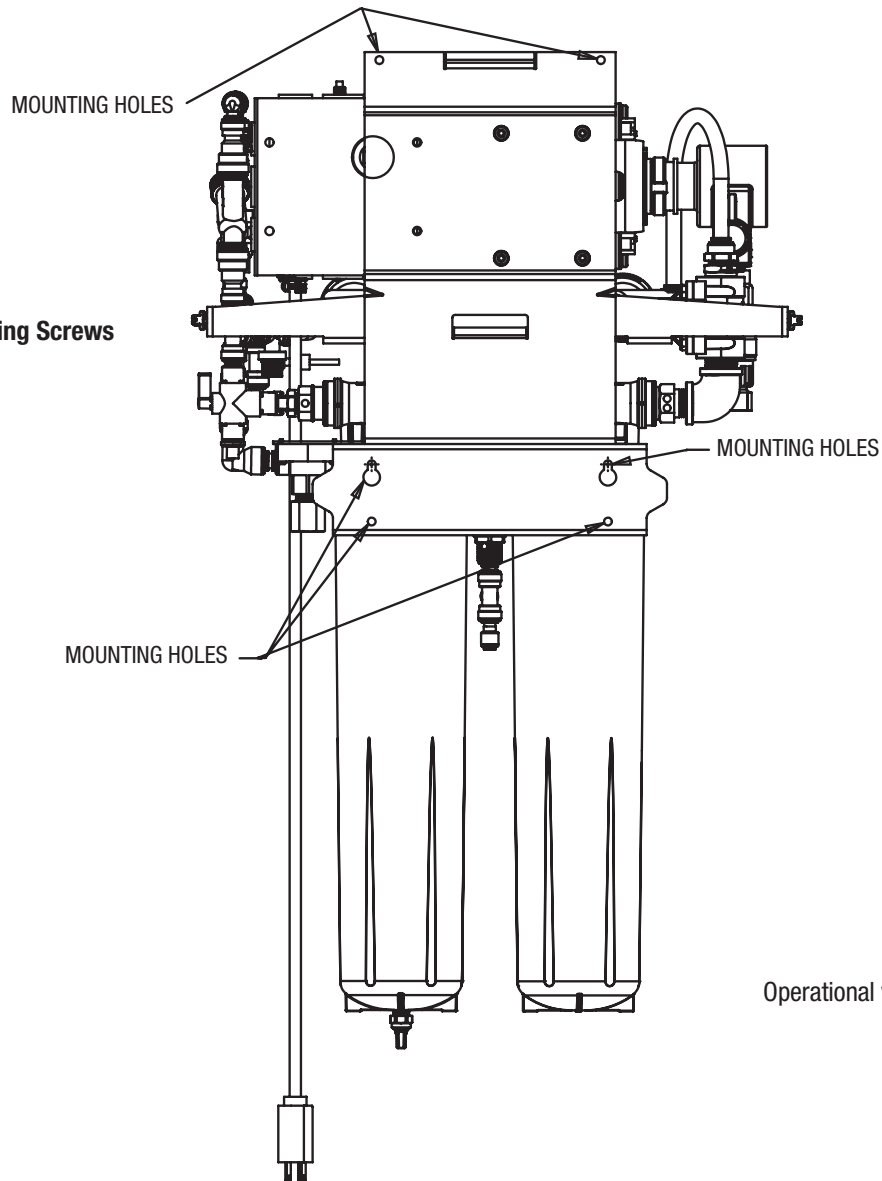

Figure 2 — Installing Mounting Screws

Operational weight - 57 lbs.

## Plumbing Connections

1. Install feed water line to marked "Inlet" 1/2" NPT inlet connection.
2. Install RO water line from marked "Tank Outlet" to pressure tank (Sold Separately). Assemble and install pressure tank fittings per instructions provided with tank.
3. Install RO water line from marked "Equipment Outlet" to the foodservice equipment. Installation of a post filter is recommended downstream of the RO system (Recommended/Sold Separately).
4. Install drain line from marked "Drain Outlet" to the drain . An approved air gap must exist between the RO system reject drain line and the drain opening to comply with state and local plumbing codes.
5. Install 1/2" Bypass line as shown on Figure 1 Plumbing Diagram (if required).
6. Check air pressure on the pressure tank using the valve on the tank. With the tank empty, the pressure should read between 10 +/- 2 psig (69 +/- 14 kPa). Adjust as required.
7. Plumbing connections for the ScaleGard™ HP reverse osmosis system are now complete.

### IMPORTANT NOTE:

The cartridges have unique keys and are color coded. The pre-filter cartridge has a blue label and is keyed to fit into the left cartridge head on the manifold. The RO membrane cartridge has a green label and is keyed to fit into the right cartridge head on the manifold.

## RO Membrane Cartridge (green label) Installation

Figure 3 — Flow Control Installation



Remove RO Membrane Cartridge Drain Plug



Remove red sanitary cap from RO Membrane cartridge. Ensure o-rings are seated into their grooves. Install with a quarter right turn until cartridge locks into position.



Insert Flow Control Into Elbow



Insert elbow into RO Membrane Cartridge drain fitting



Insert reject line into elbow. Flow control installation is now complete.

## Pre-Filter and Post Filter Cartridge (blue label) Installation

1. Remove red sanitary cap from new cartridge. Ensure o-rings are seated into their grooves and lubricate with water. Install with a quarter turn to the right until cartridge come to a complete stop. NOTE: Cartridges are keyed to fit in proper location only.

## System Start Up

1. Turn on the feedwater supply.
2. Open unit inlet shutoff valve.
3. Power the unit by plugging into electrical outlet.
4. Open Pre-Filter flush valve to vent air from system and flush for 10 gallons (approximately 5 minutes).
5. Close Pre-Filter flush valve. The unit operating pressure gauge (left gauge) should read between 110-120 psi. (See Operating Pressure instructions to adjust)
6. Complete blending valve adjustment procedure below. (See instructions below)
7. Close the blend line shut off valve. (Figure 5, #1)
8. Allow storage tank to fill until the RO system turns OFF on full tank (See chart). Tank operating pressure for the 110-120VAC version is ON at 40 psi (276 kPa, 2.76 bar) and OFF at 60 psi (414 kPa, 4.14 bar) (right gauge). Tank operating pressure for the 220-240VAC is ON at 50 psi (345 kPa, 3.45 bar) and OFF at 70 psi (483 kPa, 4.83 bar).
9. Flush membrane by opening tank line sample valve and empty storage tank to drain. Operate the system for at least 24 hours to flush the RO membrane. Discharge all water generated during the flushing procedure to drain. Close the tank line sample valve after flushing is complete.
10. Sanitize the storage tank and RO system according to the storage tank and RO system sanitizing instructions on page 11.
11. Open the blend line shut off valve (if product water blending is desired). Allow storage tank to refill. System is now ready for use.

### Required (Sold Separately)

Part Number	Pressure Volume	Approximate Time to Fill
5598408	20 gallons (76 liters)	0.6 hours
5598409	40 gallons (151 liters)	1.2 hours

Figure 4 (Reset Button)

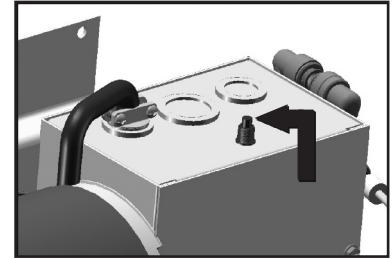

## Start Up Test Checklist

Close the tank shut off valve, open the tank line sample valve.

- Pump turns on ✓
- Water will flow thru the tank line sample valve and drain line ✓

Keep the tank shut off valve closed and close the tank line sample valve.

- Pump turns off ✓
- Water will stop flowing from the drain line. ✓
- The operating pressure gauge will read 0 psi (0 kPa) at this point. ✓
- Tank pressure gauge will read 60 psi (414 kPa, 4.14 bar) for 110-120 VAC systems and 70 psi (483 kPa, 4.83 bar) for 220-240 VAC systems ✓

Open the tank line sample valve.

- Pump will turn on. ✓
- Tank pressure gauge will read 0 psi (0 kPa). ✓
- Permeate being rinsed for first 25 seconds ✓
- After 30 seconds of operation, check production rate. ✓
- After 30 seconds of operation, check operating pressure. The operating pressure gauge should read 110-120 psi. ✓
- After 30 seconds of operation, check TDS reductions. ✓

Close the tank line sample valve and open the tank shut off valve. Allow storage tank to fill.

- Verify the tank pressure gauge increases to 60 psi (414 kPa, 4.14 bar) for 110-120 VAC systems and 70 psi (483 kPa, 4.83 bar) for 220-240 VAC systems ✓
- Verify the pump turns off and the drain line flow stops. ✓

## Blending Valve Adjustment Instructions:

### IMPORTANT NOTES:

- Typical TDS (Total Dissolved Solids) values for coffee are 80-200 ppm (parts per million) and occasionally lower for espresso, depending upon taste preference. Typical TDS valves for steam and combi ovens are less than 50ppm.
- The blending valve should be set at start-up and checked periodically. This valve is a precision metering valve that has a lock nut.
- To set blending valve use TDS monitor set in the "out" position.

1. Open the blend line shut off valve.
2. Allow the unit to run for 2 minutes.
3. To adjust blending, rotate the blending valve to the left (counterclockwise) to increase the product water TDS and to the right (clockwise) to decrease the product water TDS (See Figure 5 item #2 below). The blending valve should be opened intermittently a quarter turn at a time. Check the TDS after each incremental adjustment and again two (2) minutes after the desired TDS value is reached. Re-adjust and check, as needed. (See Figure 5-item #2 below)
4. Lock the blending valve using the lock nut.
5. After product water TDS is set, it should be checked periodically during operation to confirm it is at the desired level.

**IMPORTANT NOTE:** The TDS Monitor is push-button operated and requires two (2) 357A batteries. (Included in TDS meter)

## Membrane Flushing Instructions:

### **⚠ WARNING:**

Flush RO Membrane Cartridge: Before use this cartridge must be flushed as specified in the Installation Instructions. Discard any water generated before the flush procedure is completed. Failure to do so could cause serious injury from exposure to chemicals that can be extracted from the RO membrane during this initial flush.

1. Open the tank line sample valve.
2. Close the blend line shut off valve. (Figure 5, #1)
3. Operate the unit for 24 hours minimum to flush the RO membrane. Discharge all water generated during the flushing procedure to drain.
4. Close the tank line sample valve.
5. Open the blend line shut off valve if required for the application.
6. Allow unit to operate and fill the storage tank.

## Storage Tank and RO System Sanitizing Instructions:

Sanitizing the storage tank requires:

- Common household bleach (5.25% non-scented) or sanitizing agent
  - Eye dropper or plastic oral syringe
- a.) Unplug the unit from the electrical outlet.
  - b.) Connect a length of tubing to the tank line sample valve and route this line to drain.
  - c.) Open the tank line sample valve and empty the storage tank.
  - d.) Close the tank line sample valve
  - e.) Disconnect the 1/2" line from marked "Tank Outlet" to storage tank.
  - f.) Insert 15ml (0.5 ounces) of bleach or sanitizing agent into 1/2" line to storage tank.
  - g.) Reconnect the 1/2" line to storage tank.
  - h.) Plug the unit into the electrical outlet and operate the unit for 10 minutes.
  - i.) Unplug unit from the electrical outlet.
  - j.) Wait 4-5 hours.
  - k.) Open the tank line sample valve and empty the storage tank.
  - l.) Close tank line sample valve and remove drain tube.
  - m.) Plug the unit into the electrical outlet. Operate system until storage tank is full.
  - n.) Sanitizing is now complete.
  - o.) If there is any residual chlorine/bleach taste, drain storage tank completely a second time.

Figure 5

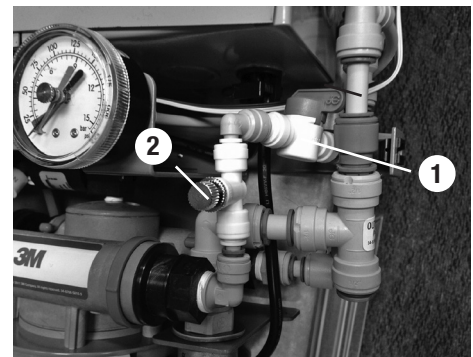

1 - blend line shutoff valve  
2 - blending valve

**Figure 6 — Unit Flow Chart**

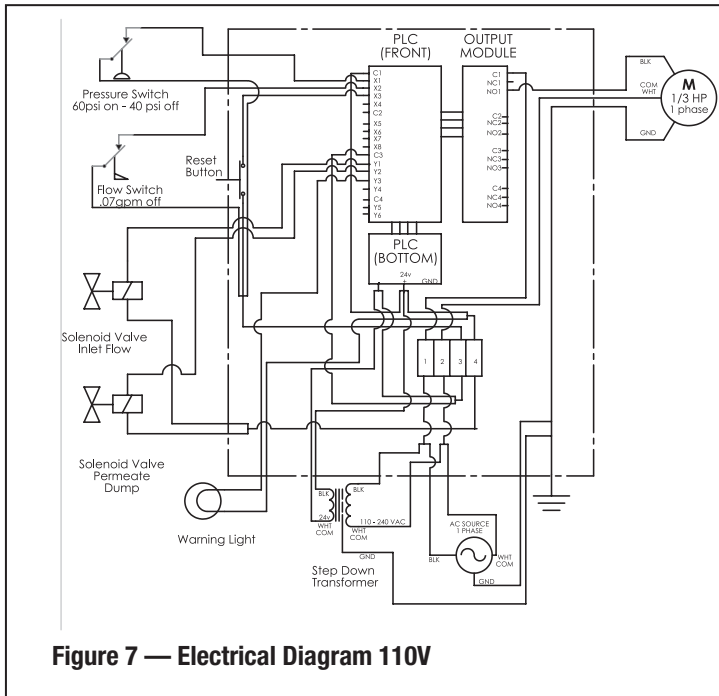
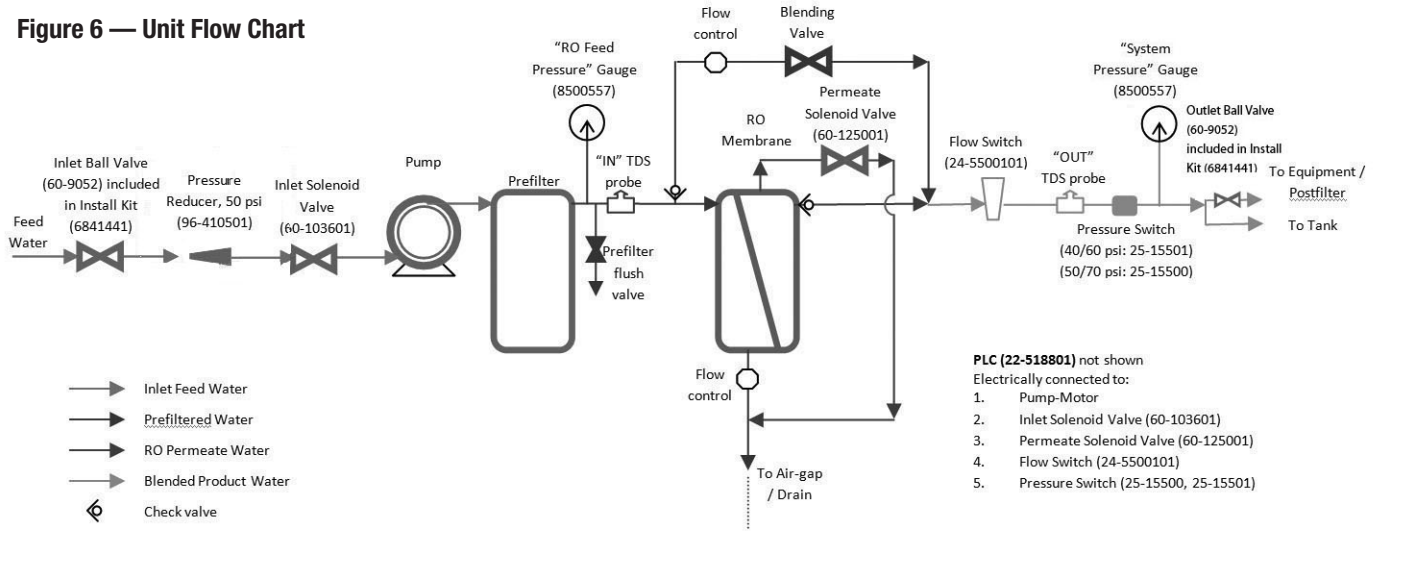

**Figure 7 — Electrical Diagram 110V**

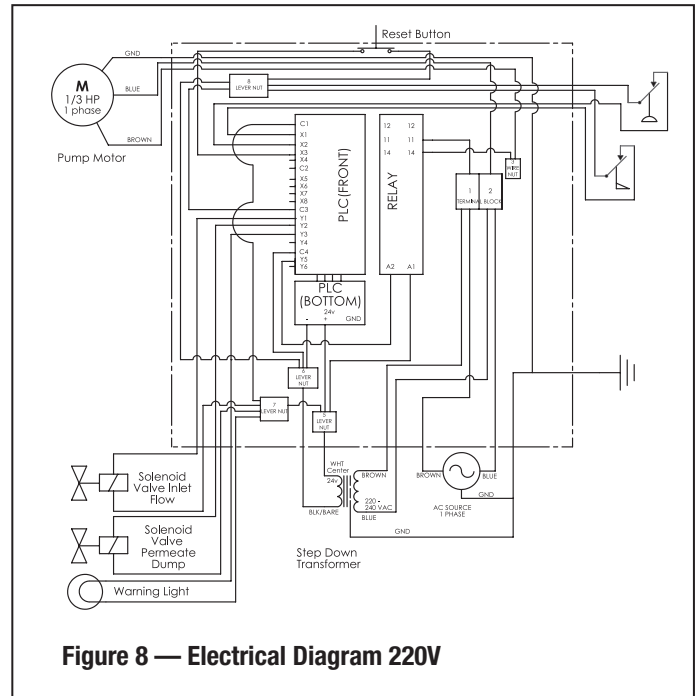

**Figure 8 — Electrical Diagram 220V**

**Advanced Diagnosis for Certified Technicians ONLY**

**Caution/Warning: High Voltage in the Control Box**

Output	LED Color	Meaning	Normal Running Condition
PWR	Green	On when the units power cord is plugged in	ON
RUN	Green	On if PLC is powered with switch in run position	ON
ERR	Green	On when PLC is not functioning properly	OFF
X1	Green	On when the pressure-switch is closed telling PLC to make water	ON
X2	Green	On when the flow-switch is closed signaling good flow	ON
X3	Green	On when the reset button is being pressed down	OFF
Y1	Red	On when the Inlet solenoid is being signaled by PLC to open (make RO-water)	ON
Y2	Red	On when the permeate rinse solenoid is being signaled by PLC to open (rinse)	On for 25 seconds then OFF
Y3	Red	On when The service indicator light is being signaled by PLC to turn on	OFF
N01 (110-120VAC)	Red	On when the motor/pump is being signaled by PLC to turn on (make RO water)	ON
Y5 (220-240VAC)	Red		

# ScaleGard™ HP PLC (Programable Logic Controller) Program Version 9.8 Sequence of Operation

Plug unit in, both the Power and Run LED's are Green

**A. If Tank Switch is > 60 psi (414 kPa, 4.14 bar) for 110-120VAC systems or 70 psi (483 kPa, 4.83 bar) for 220-240VAC systems, the unit is off on full tank**

1. Unit will cycle on when tank switch senses < 40 psi

**B. If Tank Switch is < 40 psi**

1. Inlet solenoid valve and permeate rinse solenoid open
2. 2 second delay, motor / pump start
3. 25 second delay permeate rinse solenoid closes
4. Monitoring of the flow switch starts

**a. If flow switch is closed (flow detected) unit continues to operate filling the tank**

1. Tank switch senses pressure > 60 psi (414 kPa, 4.14 bar) for 110-120VAC systems or 70 psi (483 kPa, 4.83 bar) for 220-240VAC systems
2. Motor / pump shut down
3. 5 second delay inlet solenoid valve shuts off
4. Unit is shut down on full tank.
5. When pressure in tanks fall below 40 psi (276 kPa, 2.76 bar) for 110-120VAC systems or 50 psi (345 kPa, 3.45 bar) for 220-240VAC systems, return to B.1

**b. If flow switch is open (no flow detected)**

1. No flow signal is ignored for 15 seconds and the "TOGGLE CYCLE" starts

## "TOGGLE CYCLE"

1. Motor / Pump stop
2. 2 second delay the inlet solenoid closes
3. 1 second delay the inlet solenoid opens
4. 1 second delay the motor / pump start
5. 12 second delay check flow for three consecutive readings at 2 second intervals

Note: The "TOGGLE CYCLE" can/will repeat 4 times.

**1. RETURN to NORMAL OPERATION** If the flow switch closes (sensing flow) for 3 consecutive readings during any of the "toggle cycles", the unit will return to normal operation (B.1)

**2. TOGGLE SHUT DOWN** If the flow switch opens (sensing low flow) at any time during the toggle cycle the unit will go into the TOGGLE SHUT DOWN mode

## "TOGGLE SHUT DOWN"

1. Motor / pump shut down
2. 5 second delay the inlet solenoid valve closes
3. ERROR light blinking
4. After 10 minutes the unit returns to operation (B.1)

The unit will count the number of toggle shut downs.

If the unit shuts down in the 10 minute toggle mode 10 times the shut down time is increased to 60 minute shut down.

The unit will shut down in the 60 minute shut down mode 1 time and the shut down mode will return to the 10 minute mode with the counter reset and counting to 10 again.

**3. ERROR SHUT DOWN** If the flow switch stays open (no flow) after the 4th repeat the unit will shut down in "ERROR SHUT DOWN".

1. The motor / pump shut down
2. 5 second delay inlet solenoid valve closes
3. ERROR light on solid red.
4. Unit will have to manually be restarted.

The unit can/will be reset back to normal operation during the toggle mode by:

1. Unplugging the unit or pressing the reset button on the top of the PLC box
2. Unit cycles off on full tank

## Operating Pressure Adjustment Instructions

1. Unplug the ScaleGard™ HP Reverse Osmosis Unit.
2. Remove the shroud from the unit. (See diagram)
3. Close the storage tank valve. Open tank line sample valve to relieve system pressure. Connect a length of tubing from the tank line sample valve with discharge to drain.
4. Remove the prefilter cartridge from the left cartridge head on the manifold. (See diagram)
5. Install bypass plug (3M part # 6217402) into the left cartridge head on the manifold. (Note: Operating pressure cannot be set/adjusted with used pre-filter cartridges)
6. Close the blend line shut off valve (see Figure 5 #1).
7. Remove the pressure adjustment lock nut on the water pump to access the set screw (see diagram below).
8. Plug in the ScaleGard HP, this will start the unit.
9. Operate the unit for 1 minute (minimum) before adjusting the operating pressure.
10. Use the set screw to adjust the operating pressure to 110-120 psi. (displayed on the left gauge).
11. Use an appropriate tool to make this adjustment using the screw slot. Turn the screw in to increase the operating pressure out to decrease the operating pressure. Note: A small amount of water may leak around the set screw, this is normal.
12. When the operating pressure is set, replace the lock nut and recheck the operating pressure, readjust if necessary. (Do not over tighten lock nut). Check for water leaks, repair as necessary.
13. Unplug the SGHP RO unit.
14. Remove the bypass plug and reinstall the pre filter cartridge.
15. Close the tank line sample valve. Remove tubing.
16. Open the blend line shut off valve.
17. Replace the shroud on the unit.
18. Plug in the SGHP RO unit Note: if the operating pressure is lower than the adjusted pressure, DO NOT READJUST. The reduced pressure is due to a restriction in the prefilter cartridge. It is recommended to change the prefilter cartridge.



Lock Nut/set screw

Operating Pressure Gauge



Shroud

Blend Valve Line

Pre-Filter



Bypass Plug (PN-6217402)

# Routine Maintenance Cartridge Change out Instructions (Pre/ Post Filter and RO Membrane Cartridge)

## **⚠ WARNING**

**Read entire manual. Failure to follow all guide and rules could cause personal injury or property damage.**

- Check with your local public works department for plumbing codes. You must follow their guidelines as you install the water filtration system.
- Your water filtration system will withstand up to 125 pounds per square inch (psi) water pressure.

**To reduce the risk associated with choking:**

- DO NOT allow children under 3 years of age to have access to small parts during the installation of this product.

**To reduce the risk of serious injury associated with the potential ingestion of chemicals or contaminants:**

- Do not use with water that is microbiologically unsafe or of unknown quality without adequate disinfection before or after the system.
- Flush RO Cartridge: Before use, you must flush the RO cartridge as specified in the installation instructions, and discard any water generated until flush is complete. Failure to do so could cause serious injury from exposure to chemicals that can be extracted from the RO membrane during this initial flush.
- Sanitize and Flush Tank: Before use, you must sanitize and flush the hold tank as specified in the installation instructions. Sanitizing the hold tank minimizes the risk for exposure to contaminants. Failure to flush the hold with water after sanitizing could cause serious injury from exposure to sanitizer present.

## **NOTICE**

**To reduce the risk associated with property damage due to water leakage or flooding:**

- Read and follow Use Instructions provided with the original system prior to use of this replacement cartridge.
- The pre-filter and post-filter cartridges **MUST** be changed every 12 months, or sooner if the rated capacity is achieved or a noticeable reduction in flow occurs.
- The RO membrane cartridge **MUST** be changed every 24 months, or sooner if a noticeable decrease in flow or TDS reduction occurs.
- Failure to replace the filters and RO membrane cartridges at recommended intervals may lead to reduced filter performance and failure, causing property damage from water leakage or flooding.
- Protect from freezing, remove all cartridges when temperatures are expected to drop below 40°F (4.4°C).
- DO NOT install systems in areas where ambient temperatures may go above 100°F (37.8°C).
- DO NOT install on hot water supply lines. The maximum operating water temperature of this filter system is 100°F (37.8°C).
- DO NOT install if water pressure exceeds 125 psi (862 kPa). Contact a plumbing professional if you are uncertain how to check your water pressure.

## **IMPORTANT NOTE:**

The cartridges have unique keys and are color coded. The pre-filter cartridge has a blue label and is keyed to fit into the left cartridge head on the manifold. The RO membrane cartridge has a green label and is keyed to fit into the right cartridge head on the manifold.

## **Shut Off Procedure**

RO membrane cartridge **MUST** be changed every 24 months or sooner. The pre-filter and post filter cartridges **MUST** be changed every 12 months or sooner.

1. Unplug system from the electrical outlet, which will shutoff feedwater to RO unit.
2. Confirm the operating pressure gauge (left) decreases to 0 psi. Note: Tank pressure gauge (right) will not decrease from the observed pressure.

## **Pre-Filter Cartridge (blue label) Replacement:**

1. Push and hold yellow tab to release cartridge locking mechanism while simultaneously rotating cartridge to the left.
2. Using both hands and holding the cartridge from the bottom, rotate the cartridge a quarter turn to the left and gently pull down.  
NOTE: A small amount of water will drain from manifold as cartridge is removed.
3. Remove red sanitary cap from new cartridge. Ensure o-rings are seated into their grooves. Install with a quarter turn to the right until cartridge come to a complete stop. NOTE: Cartridges are keyed to fit in proper location only.

## **RO Membrane Cartridge (green label) Replacement:**

1. Remove the reject tubing from the RO membrane cartridge. (See Figure 1).
2. Push and hold yellow tab to release RO membrane cartridge locking mechanism while simultaneously rotating RO membrane cartridge to the left.
3. Using both hands and holding the RO membrane cartridge from the bottom, rotate the RO membrane cartridge a quarter turn to the left and gently pull down. NOTE: A small amount of water will drain from manifold as cartridge is removed.

# Routine Maintenance Cartridge Change out Instructions (Pre-Filter and RO Membrane Cartridge)

## RO Membrane Cartridge (green label) Replacement Cont.:

4. Remove sanitary cap from new RO membrane cartridge. Ensure o-rings are seated into their grooves. Remove drain fitting plug from new RO membrane cartridge. Install with a quarter turn to the right until RO membrane cartridge comes to a complete stop.  
NOTE: RO membrane cartridges are keyed to fit in proper location only.
5. Insert new flow control into the elbow (included with new RO membrane cartridge). Install this sub assembly into the drain fitting (cartridge bottom) See Figure 3.
6. Connect reject line into elbow.
7. **IMPORTANT:** Complete System Start Up and Membrane Flushing procedure before system is brought back into use. See pages 10-11.

**Figure 9 (How to Use "Push-in" Connectors)**

This product is outfitted with a user friendly 'Push In' connector at the vent valve. Proper use of the connectors is shown in the figure below. It is most important that the tubing selected for use with these connectors be of high quality, exact size and roundness, and with no surface nicks or scratches. If it is necessary to cut the tubing, use a plastic tubing cutter or sharp razor knife. Make a clean square cut. Should a leak occur at a "Push-In" connector, the cause is usually a problem with the tubing.

**To Fix:**

1. Relieve pressure
2. Release tubing
3. Cut off at least 1/4" from end
4. Reattach tubing
5. Confirm connection is leak free

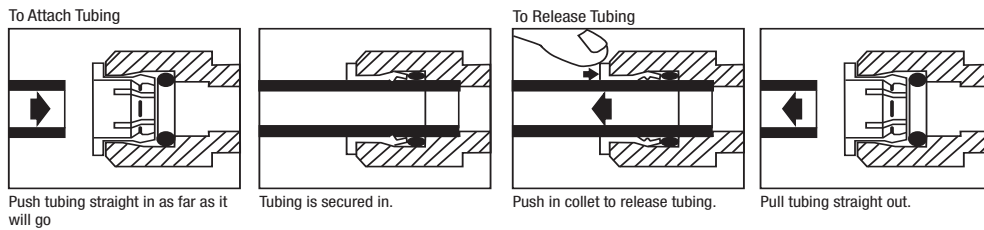

# Troubleshooting Guide

Technical Support - 1-866-990-9785

Problem	Possible Cause	Solution	Notes
Unit Runs Low or Out of Water	Undersized tank for store demand	Install additional storage tank capacity	Contact Dealer
	RO production is to low for store demand	Install RO add-on head and cartridge	Contact Dealer
		Upgrade from HFRO 500 to HFRO 700 Cartridge	
	Slow leak in the distribution line	Repair leak	The unit produced RO water slowly. A dripping leak can prevent the tank from filling.
RO membrane flow control improperly installed or missing	Properly install RO membrane flow control	Note: Reference RO cartridge change-out instructions	
System shuts down and "service" indicator light turns on blinking	Pre-Filter plugs left hand gauge reads less than 90	Replace Pre-Filter	—
	Low production rate	Wait for 10-60 minutes to see if system restarts	
	RO membrane fouls, low production	Replace RO membrane	
System shuts down and "service" indicator light turns on solid	Pre-Filter plugs left hand gauge reads less than 90	Replace Pre-Filter	A more frequent schedule change-out may be needed (Refer to Challenge Water Recommendations on page 6)
	RO membrane fouls (normal conditions)	Replace RO membrane	Check for: 1. feedwater pressure, 2. production flow rate, 3. drain flow rate before replacing RO membrane
		Ensure drain line is not kinked or plugged. Replace if needed.	
	RO membrane fouls (high feed water hardness/TDS)	Install RO add-on head and cartridge	Contact Dealer
		Install a HFRO 33% Recovery Kit	
		Install water softener upstream	
	RO membrane fouls (high particle load in incoming water)	Install prefilter and RO expansion heads and cartridges	
	Interrupted feedwater supply	Press Reset button on top of electrical enclosure	Reference system startup procedure
Water temperature below 50 °F	Install RO expansion head and cartridge		
Low feedwater pressure (below 30 psi)	Contact plumber to resolve problem	Reference system startup procedure once low feed water problem is resolved	
Iron or Manganese in incoming water	Contact your dealer/distributor to install specific iron or manganese reduction system		
TDS of product water too low	Blend too low	Re-adjust blending valve to allow more blending	Reference Blending Valve Adjustment
TDS of product water too high	Blend to high	Re-adjust blending valve to allow less blending	Reference Blending Valve Adjustment
TDS of product water too high with no blending	RO membrane needs to be replaced	Replace RO membranes	—
TDS monitor not operating	Low battery	Replace TDS monitor batteries	—

## Replacement Parts

Part Number	Description
96-410501	Pressure Reducer/Regulator (Contact Dealer)
60-9052	Inlet ball valve (Contact Dealer)
22-518801	Pre-programmed PLC for <a href="#">5629101</a> and <a href="#">6239301</a> (Contact Dealer)
<a href="#">25-212401</a>	Relay Output Module for <a href="#">5629101</a> and <a href="#">6239301</a>
22-518802	Pre-programmed PLC for <a href="#">6239302</a> , 629303, 6239304 (Contact Dealer)
22-115401	Relay Output Module for <a href="#">6239302</a> , 6239303, and 6239304
8500557	Pressure Gauge (Contact Dealer)
60-125001	Permeate Solenoid (Contact Dealer)
85-9274	Shroud (Contact Dealer)
<a href="#">89-3220101</a>	Pump Head (Contact Dealer)
89-2302	Pump Motor (Contact Dealer)
<a href="#">5613529</a>	<a href="#">HF90-CL-RO</a> Pre-Filter
<a href="#">5626903</a>	HFRO 500 Cartridge
5626904	HFRO 700 Cartridge
<a href="#">50-93201</a>	HFRO 33% Recovery Kit
<a href="#">6232631</a>	TDS Monitor
<a href="#">24-500101</a>	Flow Switch
25-15501	Pressure Switch (40/60 psi)
25-15500	Pressure Switch (50/70 psi)
<a href="#">60-103601</a>	Inlet Solenoid (Contact Dealer)
6217402	Bypass Plug
<a href="#">5613303</a>	Post Filter <a href="#">HF40</a> Replacement Cartridge for <a href="#">BEV140</a> (Recommended/Sold Separately)
<a href="#">5613403</a>	Post Filter <a href="#">HF60</a> Replacement Cartridge for <a href="#">BEV160</a> (Recommended/Sold Separately)
<a href="#">5613503</a>	Post Filter <a href="#">HF90</a> Replacement Cartridge for <a href="#">BEV190</a> (Recommended/Sold Separately)

# Notes

**Product Use:**

Many factors beyond 3M Purification Inc.'s (3M's) control and uniquely within user's knowledge and control can affect the use and performance of a 3M product in a particular application. User is solely responsible for evaluating the 3M product and determining whether it is fit for a particular purpose and suitable for user's method of application.

**Warranty, Limited Remedy, and Disclaimer:**

3M warrants that this product (excluding filter cartridge or filter membrane) will be free from defects in material and manufacture for the period of (1) year from the date of purchase. The filter cartridge or membrane is warranted to be free from defects in material and manufacture for one (1) year. No warranty is given as to the service life of any filter cartridge or membrane as it will vary with local water conditions and water consumption. **3M MAKES NO OTHER WARRANTIES OR CONDITIONS, EXPRESS OR IMPLIED, INCLUDING, BUT NOT LIMITED TO, ANY IMPLIED WARRANTY OR CONDITION OF MERCHANTABILITY OR FITNESS FOR A PARTICULAR PURPOSE OR ANY IMPLIED WARRANTY OR CONDITION ARISING OUT OF A COURSE OF DEALING, CUSTOM OR USAGE OF TRADE.**

If the 3M product does not conform to this warranty, then the sole and exclusive remedy is, at 3M's option, replacement of the 3M product or refund of the purchase price.

**Limitation of Liability:**

Except where prohibited by law, 3M will not be liable for any loss or damage arising from the 3M product, whether direct, indirect, special, incidental or consequential, regardless of the legal theory asserted, including warranty, contract, negligence or strict liability.



**3M Purification Inc.**  
400 Research Parkway  
Meriden, CT 06450, U.S.A.  
Tel (866) 990-9785  
(203) 237-5541  
Fax (203) 238-8701  
www.3MFoodservice  
www.3Mpurification.com

3M and ScaleGard are trademarks of 3M Company.  
© 2020 3M Company. All rights reserved.  
Please recycle. Printed in U.S.A.  
34-8726-0696-6