

3M™ Water Filtration Products

## Scale Feeder Manifold Water Filtration System Instruction Manual

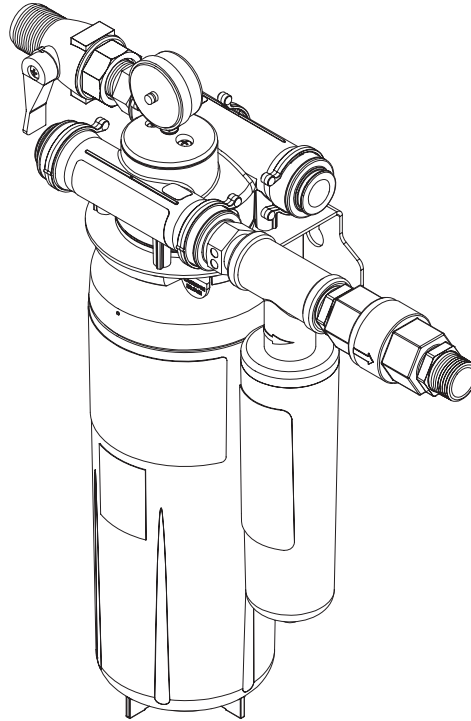

**For SF1XX**

**High Flow Series Water Filtration Systems**

Installer: Please leave this manual with owner/operator.

**3M**

# 3M™ Water Filtration Products

## Table of Contents

Safety Information .....	2
Warning Statements .....	2
Caution/Important Notes .....	3
SF1XX Manifold and ScaleGARD HT Systems .....	3
Inlet and Outlet Connections.....	3
Product Dimensions.....	4
How to Use The “Inlet/Outlet” Fitting Retention Clips .....	4
Equipment Installation .....	5
Equipment Start-up Procedure .....	6
Cartridge Change-out Procedure .....	6
Troubleshooting .....	6
Replacement Parts Listing .....	7
Warranty.....	8

## ***SAFETY INFORMATION***

Read, understand, and follow all safety information contained in these instructions prior to installation. Retain these instructions for future reference.

### **Intended Use:**

The manifold and water filtration systems are intended for use in filtering potable water in the foodservice industry and have not been evaluated for other uses. These systems are installed at the point of use and must be installed as specified in the installation instructions.

<b>EXPLANATION OF SIGNAL WORD CONSEQUENCES</b>	
<b>⚠ WARNING</b>	Indicates a potentially hazardous situation, which, if not avoided, could result in death or serious injury and/or property damage.
<b>⚠ CAUTION</b>	Indicates a potentially hazardous situation which, if not avoided, may result in minor or moderate injury and/or property damage.
<b>CAUTION</b>	Indicates a potentially hazardous situation, which, if not avoided, may result in property damage.

<b>⚠ WARNING</b>
<p><b>To reduce the risk associated with choking:</b></p> <ul style="list-style-type: none"> <li>• Do not allow children under 3 years of age to have access to small parts during the installation of this product.</li> </ul>
<p><b>To reduce the risk associated with the ingestion of contaminants:</b></p> <ul style="list-style-type: none"> <li>• Do not use with water that is microbiologically unsafe or of unknown quality without adequate disinfection before or after the system.</li> </ul>
<p><b>To reduce the risk associated with hazardous voltage due to an installer drilling through existing electric wiring or water pipes in the area of installation:</b></p> <ul style="list-style-type: none"> <li>• Do not install near electric wiring or piping which may be in path of a drilling tool when selecting the position to mount the filter bracket.</li> </ul>
<p><b>To reduce the risk of physical injury:</b></p> <ul style="list-style-type: none"> <li>• Depressurize system as shown in manual prior to cartridge removal.</li> </ul>
<p><b>To reduce the risk associated with back strain:</b></p> <ul style="list-style-type: none"> <li>• Follow safe lifting procedures.</li> </ul>

## CAUTION

### To reduce the risk associated with property damage due to water leakage:

- **Read and follow** Use Instructions before installation and use of this system.
- Installation and Use **MUST** comply with all state and local plumbing codes.
- **Protect from freezing**, remove filter cartridge when temperatures are expected to drop below 40°F (4.4°C);
- **Do not install** on hot water supply lines. The maximum operating water temperature of this filter system is 100°F (37.8°C).
- **Do not install** if water pressure exceeds 125 psi (862 kPa). If your water pressure exceeds 80 psi (552 kPa), you must install a pressure limiting valve. Contact a plumbing professional if you are uncertain how to check your water pressure.
- **Do not install** where water hammer conditions may occur. If water hammer conditions exist, you must install a water hammer arrester. Contact a plumbing professional if you are uncertain how to check for this condition.
- Any non-metallic fittings used in the installations must be of adequate rating for the line pressure.
- **Do not** use a torch or other high temperature sources near filter system, cartridges, plastic fittings or plastic plumbing.
- On plastic fittings, never use pipe sealant or pipe dope. Use PTFE thread tape **only**, pipe dope properties may deteriorate plastic.
- Take care when using pliers or pipe wrenches to tighten plastic fittings, as damage may occur if overtightening occurs.
- **Do not** install in direct sunlight or outdoors.
- **Do not** install near water pipes which will be in path of a drilling tool when selecting the position to mount the bracket.
- Mount filter in such a position as to prevent it from being struck by other items used in the area of installation.
- Ensure that the location and fasteners will support the weight of the system (Approx. 10.5 lbs [4.8 kg]) when installed and full of water.
- Ensure all tubing and fittings are secure and free of leaks.
- The disposable filter cartridge **MUST** be replaced every 12 months or at the rated capacity or if a noticeable reduction in flow rate occurs.

## IMPORTANT NOTES

- Failure to follow instructions may void warranty.
- Allow a minimum of 3" (7.6 cm) clear space under filter to facilitate cartridge change.
- Install with the inlet and outlet ports as labeled. Make sure not to reverse connections.
- Some local codes may require the use of a licensed plumber or certified installer when disrupting a potable water line.

### SF1XX Manifold and ScaleGARD™ HT Systems

SF1XX High Flow series water filtration systems combine chlorine taste and odor reduction with particulate reduction, and help protect equipment from the potentially harmful effects of scale formation, even at application temperatures to 200°F (93°C). The inlet water enters the manifold on the left rear side and exits through the scale-inhibitor feeder on the right front side. The capacity of the system is equal to the flow rate and capacity rating for the filter cartridges used.

### Inlet and Outlet Connections

The water inlet is on the left rear side and the outlet is on the right front side. These are identified with labels. The fitting size is 3/4" NPT (Male). A built-in check valve (non-return) is incorporated into the outlet.

## Product Dimensions

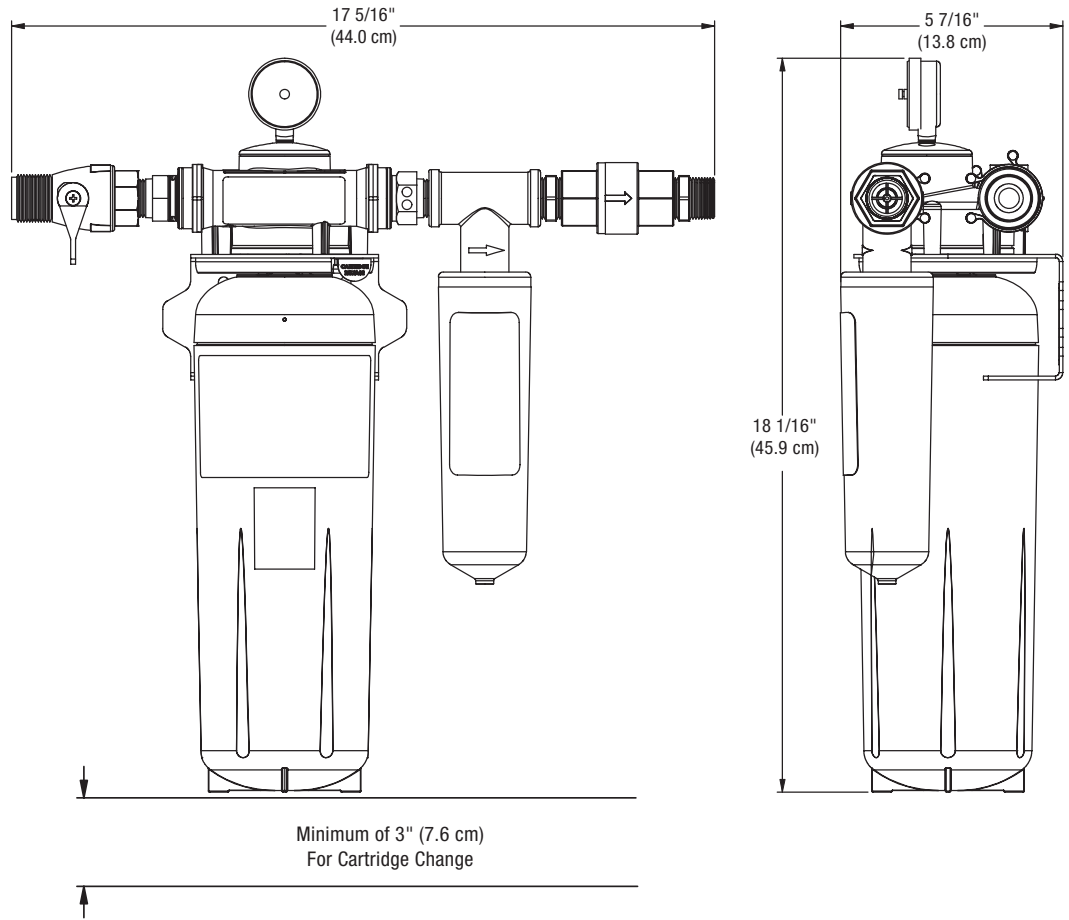

## How to Use the Inlet/Outlet Fitting Retention Clips

This product is outfitted with inlet/outlet fittings. The fittings can be attached or removed from the system without tools. Retention clips are semi-circular in shape with three internal tabs, bottom, center and top. Tab interlaces with windows in the manifold head near each connection port. Clip is flexible and easily assembled following these instruction and illustrations.

1. Insert fitting into manifold.
2. With fitting inserted into manifold port, snap clip into place beginning at the bottom window
3. Push center tab into center window.
4. Finally push top tab into top window.

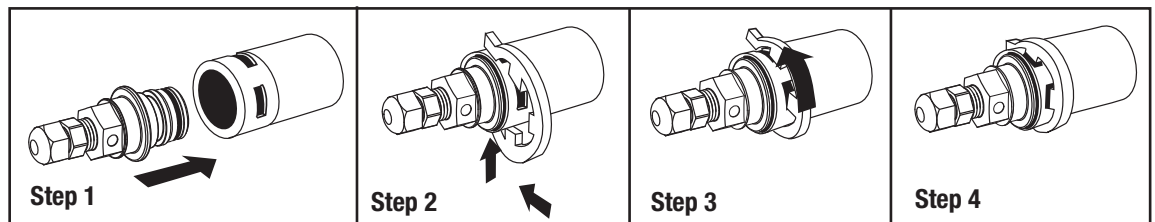

## Equipment Installation

### CAUTION

#### To reduce the risk associated with property damage due to water leakage:

- **Do not** use a torch or other high temperature sources near filter system, cartridges, plastic fittings or plastic plumbing.
- On plastic fittings, never use pipe sealant or pipe dope. Use PTFE thread tape **only**, pipe dope properties may deteriorate plastic.
- Take care when using pliers or pipe wrenches to tighten plastic fittings, as damage may occur if overtightening occurs.
- **Do not** install near water pipes which will be in path of a drilling tool when selecting the position to mount the bracket
- Mount filter in such a position as to prevent it from being struck by other items used in the area of installation.
- Ensure that the location and fasteners will support the weight of the system when installed.
- Ensure all tubing and fittings are secure and free of leaks.

### IMPORTANT NOTES

- Failure to follow instructions may void warranty.
- Allow a minimum of 3" (7.6 cm) clear space under filter to facilitate cartridge change.
- Install with the inlet and outlet ports as labeled. Make sure not to reverse connections.
- Some local codes may require the use of a licensed plumber or certified installer when disrupting a potable water line.

## The SF1XX manifold may be used with metal or non-metallic piping systems.

### CAUTION

#### To reduce the risk associated with property damage due to water leakage:

- Any non-metallic fittings used in the installations must be of adequate rating for the line pressure.

1. Shut off incoming cold water supply.
2. Select the installation location. **IMPORTANT NOTE:** Allow a minimum of 3 in (7.6 cm) of space below the cartridge for change-outs.
3. Select fasteners (not included) and tools appropriate for the installation location (wall, support structure mounted to wall studs, concrete, etc.).

### CAUTION

#### To reduce the risk associated with property damage due to water leakage:

- Ensure that the location and fasteners will support the weight of the system (Approx. 10.5 lbs [4.8 kg]) when installed and full of water.

4. Mount the manifold/filter system to a wall using the mounting holes provided on the back plate of the metal bracket.
  - It is recommended to first draw a level line on the mounting surface at the height of the fasteners.
  - Mark the location of the fasteners using the bracket as a template or by measuring the distance between the mounting holes.
  - Install the fasteners and allow 1/4"-3/8" (6-10 mm) of each fastener to protrude from the surface.
  - Install the manifold onto the fasteners.
  - Tighten the fasteners.
5. Install inlet (left rear) and outlet fittings (right front). All connections terminate with a 3/4" NPT (male) fitting. The inlet kit includes the fitting and a ball valve. The kit for the right front side outlet includes the fitting, a stainless-steel tee, a nipple, a check valve and another nipple. Refer to section "How to Use the Inlet/Outlet Fitting Retention Clips" are on page 4. (PTFE tape is not included).
6. Remove the sanitary caps from the cartridge, and apply a light coat of water or food-grade lubricant to the o-rings on each of the cartridges.
7. Align the tabs of the water filter cartridge with the slots in the retaining plate and insert the cartridge into the manifold.
8. Turn the cartridge to the right until a clicking sound is heard; the clicking sound indicates the cartridge is properly engaged.
9. Install the scale-inhibitor cartridge by engaging the threads in the stainless steel tee and turning to the right (clockwise) until snug, regardless of the final label orientation.

**Equipment Start-up Procedure**

1. Turn on incoming water to system.
2. Pressurize system by rotating the inlet ball valve handle 1/4 turn counter-clockwise to the “ON” position.
3. Check for leaks.
4. Use any downstream vent to remove trapped air.
5. Flush system in accordance with the Performance Data Sheet for the water filter cartridge. System is now ready to use.

**Cartridge Change-out Procedure**

<b>CAUTION</b>
<p><b>To reduce the risk associated with property damage due to water leakage:</b></p> <ul style="list-style-type: none"> <li>• <b>Read and follow</b> Use Instructions before installation and use of this system.</li> <li>• Installation and Use <b>MUST</b> comply with all state and local plumbing codes.</li> <li>• The disposable filter cartridge <b>MUST</b> be replaced every 12 months or at the rated capacity or if a noticeable reduction in flow rate occurs.</li> </ul>

The water filter cartridge will need to be changed every 6-12 months or when low pressure is indicated on the manifold’s pressure gauge, whichever occurs first. Depending on local water quality, you may need to change the cartridges prior to the recommended change-out.

1. Shut off the inlet water by rotating the inlet ball valve 1/4 turn clockwise to the “OFF” position.
2. Depressurize system.
3. Push tab to release cartridge locking mechanism while simultaneously rotating cartridge slightly to the left.
4. Using both hands and holding cartridge from the bottom, rotate the cartridge a quarter turn to the left and gently pull down. **IMPORTANT NOTE:** A small amount of water will drain from manifold as cartridge is removed.
5. Remove sanitary cap from new cartridge. Install cartridge with a quarter turn to the right until cartridge comes to a complete stop.
6. Remove the small scale inhibitor cartridge by rotating to the left (counterclockwise) until the threads are disengaged. Replace with a new cartridge by rotating to the right (clockwise) until the threads are fully engaged and snug, regardless of final label orientation.
7. Slowly turn the inlet ball valve on the manifold 1/4 counter-clockwise to the “ON” position and check for leaks.
8. Flush system in accordance with the Performance Data Sheet. System is now ready for use.

**Troubleshooting**

No water flow through system	Inlet valve closed	Check shut-off valve position
	Filter clogged	Replace cartridge
Not enough water to the downstream application(s)	Low incoming water pressure	Check source
	Filter clogged	Replace cartridge
Short filter life	Temporarily dirty water	Change cartridge or install an additional upstream pre-filter.

## Replacement Parts Listing

Item	Part no.	Description	Qty*	Function
1	6228601	SF1XX Manifold Assembly	1	Assembly, complete
2a	56134-07	HF65 Replacement Cartridge for SF165 System	1	Water filtration
2b	See Catalog for Options	Replacement Cartridge Options	1	Water filtration
3	5582106	HF8-S Replacement Cartridge	1	Scale-inhibitor addition
4	85005-49	Pressure gauge	1	Monitor outlet water pressure
5	85-8528	Clip	1	Retain inlet/outlet fittings
6	63597320	O-ring	1	Seal inlet/outlet fittings
7	6225005	Inlet fitting kit –left rear	1	Inlet fitting with ball valve
8	6225007	Outlet fitting kit – right front	1	Outlet to equipment
9	60-235380	3/4" x 3/4" ball valve	1	Inlet water shut-off
10	Inquire	Retainer Kit	1	Secure cartridge

\*Per part number, not per system or assembly.

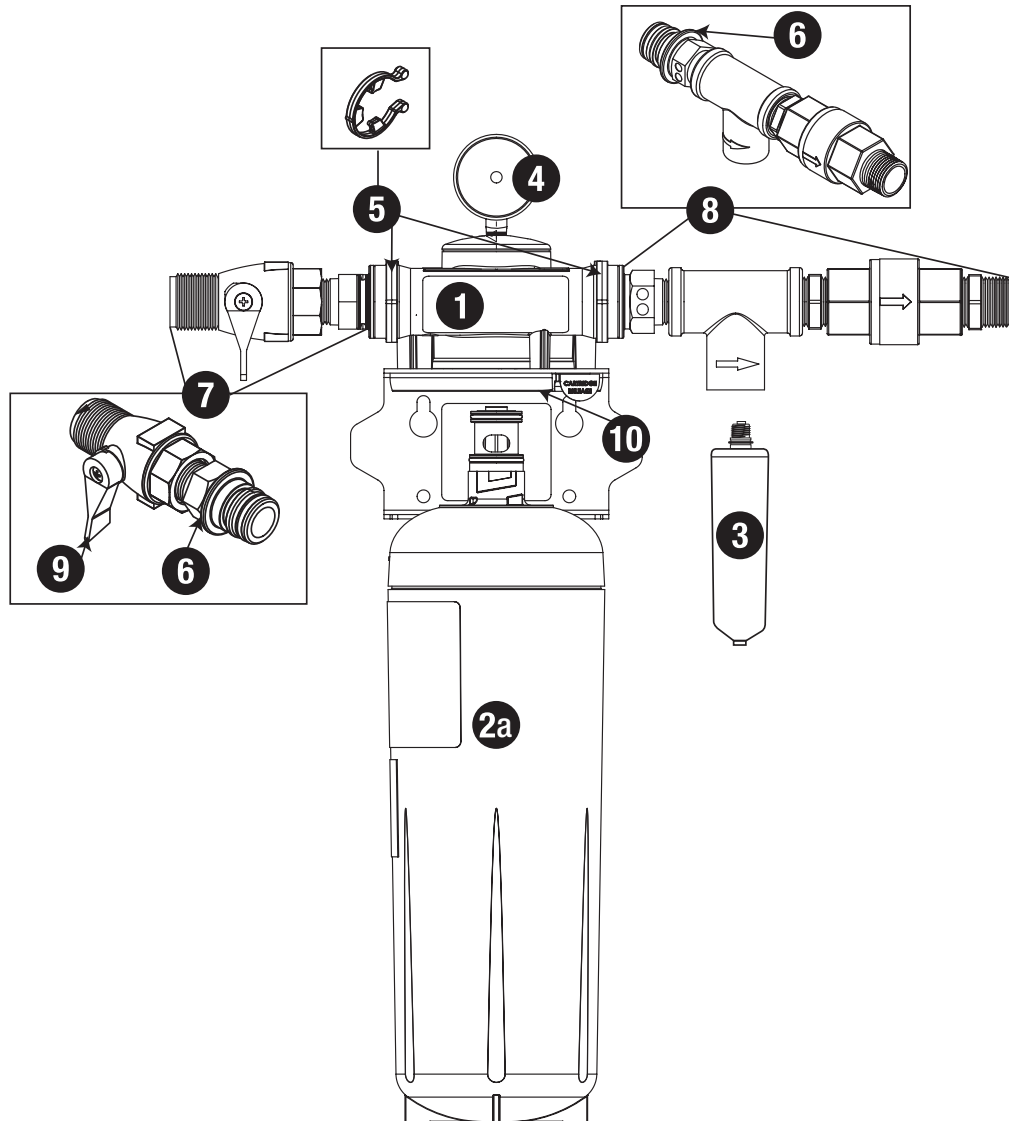

### Limited Warranty

3M Purification Inc. warrants SF1XX only to be free from defects in material and workmanship for five (5) years from the date of purchase. The disposable filter cartridge is warranted from defects in material and workmanship for a period of one (1) year from the date of purchase. This warranty does not cover failures resulting from abuse, misuse, alterations or damage not caused by 3M Purification Inc. or failure to follow installation and use instructions. No warranty is given as to the service life of any filter cartridge or membrane as it will vary with local water conditions and consumption. **3M PURIFICATION INC. MAKES NO OTHER WARRANTIES OR CONDITIONS, EXPRESS OR IMPLIED, INCLUDING, BUT NOT LIMITED TO, ANY IMPLIED WARRANTY OR CONDITION OF MERCHANTABILITY OR FITNESS FOR A PARTICULAR PURPOSE OR ANY IMPLIED WARRANTY OR CONDITION ARISING OUT OF A COURSE OF DEALING, CUSTOMER OR USAGE OF TRADE.** If the Product fails to satisfy this Limited Warranty during the warranty period, 3M Purification Inc., at its option, will replace the Product or refund your Product purchase price. This warranty does not cover labor. **The remedy stated in this paragraph is Customer's sole remedy and 3M Purification Inc.'s exclusive obligation.**

This warranty gives you specific legal rights, and you may have other rights which may vary from state to state, or country to country. For any warranty questions, please call 866.990.9785 or mail your request to: Warranty Claims, 3M Purification Inc., 400 Research Parkway, Meriden, CT 06450. Proof of purchase (original sales receipt) must accompany the warranty claim, along with a complete description of the Product, model number and alleged defect.

**Limitation of Liability:** 3M Purification Inc. will not be liable for any loss or damage arising from this 3M Purification Inc. product, whether direct, indirect, special, incidental, or consequential, regardless of the legal theory asserted, including warranty, contract, negligence or strict liability. Some states and countries do not allow the exclusion or limitation of incidental or consequential damages, so the above limitation or exclusion may not apply to you.

