

INSTALLATION AND OPERATING INSTRUCTIONS

HWS SERIES HOT WATER SOFTENERS

MODELS:
HWS050
HWS100

Installer, please leave with homeowner.



3M Purification Inc.
400 Research Parkway
Meriden, CT 06450, USA
Toll Free: 866.990.9785
Worldwide: 203.237.5541
Fax: 203.238.8701
www.3Mfoodservice.com
www.3Mpurification.com



SAFETY INFORMATION

Read, understand, and follow all safety information contained in these instructions prior to installation and use of the 3M HWS hot water softeners. Retain these instructions for future reference.

Intended use:

The HWS hot water softeners are intended for use in softening hot water in Foodservice installations. The system is intended for indoor installations near the entry point of a foodservice water line, and must be installed by qualified professional installers according to these installation instructions.

EXPLANATION OF SIGNAL WORD CONSEQUENCES	
⚠ WARNING	Indicates a potentially hazardous situation, which, if not avoided, could result in death or serious injury and/or property damage.
⚠ CAUTION	Indicates a potentially hazardous situation which, if not avoided, may result in minor or moderate injury and/or property damage.
CAUTION	Indicates a potentially hazardous situation, which, if not avoided, may result in property damage.

⚠ WARNING
To reduce the risk associated with ingestion of contaminants due to use with water that is microbiologically unsafe or of unknown quality:
<ul style="list-style-type: none"> Do not use with water that is microbiologically unsafe or of unknown quality without adequate disinfection before or after the system.
To reduce the risk associated with hazardous voltage:
<ul style="list-style-type: none"> If the electrical system requires use of the cold water system as an electrical safety ground, a jumper must be used to ensure a sufficient ground connection across the softener installation piping — refer installation to qualified personnel. Do not use the softener if the wall-mounted power supply is damaged — contact qualified service personnel for repair.
To reduce the risk associated with back strain:
<ul style="list-style-type: none"> Follow safe lifting procedures.

CAUTION
To reduce the risk associated with property damage due to water leakage:
<ul style="list-style-type: none"> Read and follow Use Instructions before installation and use of this system; Installation must comply with existing state or local plumbing codes; Protect from freezing. Drain system when temperatures drop below 40°F (4.4°C); Do not install if water pressure exceeds 100 psi (689 kPa). If the system water pressure exceeds 100 psi, the installation must use a pressure limiting valve. Contact a licensed plumbing professional if you are uncertain how to check your water pressure; Do not install system where water lines could be subjected to vacuum conditions without appropriate measures for vacuum prevention; When water supply is shut off, shut off fuel or electric power to water heater; Do not use torches or other heat sources near plastic plumbing, as damage may occur; Take care when using pliers or pipe wrenches to tighten plastic fittings, as damage may occur; On plastic fittings, use thread sealing tape only. Never use pipe sealant or pipe dope on plastic fittings, as damage may occur; Do not bend spring on float assembly or damage to the vent may result; Do not install this system in direct sunlight or outdoors without protection from precipitation.
To reduce the risk associated with property damage due to plugged water lines:
<ul style="list-style-type: none"> Pay particular attention to correct orientation of control valve. Water flow should match arrow on control valve. The Inlet and Outlet of other water treatment equipment products will vary depending on the control valve brand used.

IMPORTANT NOTES
<ul style="list-style-type: none"> Failure to follow instructions may result in leakage and will void warranty.

Limited Warranty

3M Purification Inc. warrants HWS050 and HWS100 will be free from defects in material and manufacture for the following periods from the date of purchase:

- One (1) year on the entire unit
- Five years on mineral tank only (does not include internal components)
- Five years on control valve body only (does not include internal or external components)
- Five years on salt storage container and components.*

This warranty does not cover failures resulting from abuse, misuse, alteration or damage not caused by 3M Purification Inc. or failure to follow installation and use instructions. **3M PURIFICATION INC. MAKES NO OTHER WARRANTIES OR CONDITIONS, EXPRESS OR IMPLIED, INCLUDING, BUT NOT LIMITED TO, ANY IMPLIED WARRANTY OR CONDITION OF MERCHANTABILITY OR FITNESS FOR A PARTICULAR PURPOSE OR ANY IMPLIED WARRANTY OR CONDITION ARISING OUT OF A COURSE OF DEALING, CUTOMER OR USAGE OF TRADE.** If this Product fails to satisfy this Limited Warranty during the warranty period, 3M Purification Inc. will replace the Product or refund your Product purchase price. This warranty does do cover labor. **The remedy stated in this paragraph is the Customer’s sole remedy and 3M Purification’s exclusive obligation.**

This warranty gives you specific legal rights, and you may have other rights which vary from state to state, or country to country. For any warranty questions, please call 855.3M.WATER (855.369.2837) or mail your request to: Warranty Claims, 3M Purification Inc., 400 Research Parkway, Meriden, CT 06450. Proof of purchase (original sales receipt) must accompany the warranty claim, along with a complete description of the Product, model number and alleged defect.

Limitation of Liability: 3M Purification Inc. will not be liable for any loss or damage arising from this 3M Purification Inc. product, whether direct, indirect, special, incidental, or consequential, regardless of the legal theory asserted, including warranty, contract, negligence or strict liability. Some states and countries do not allow the exclusion or limitation of incidental or consequential damages, so the above limitation or exclusion may not apply to you.

*water softeners only

<p>WATER TREATMENT SYSTEM PRODUCT REGISTRATION CARD</p> <p style="text-align: center;">3M Purification Inc., 400 Research Parkway, Meriden, CT U.S.A.</p> <div style="border: 1px solid black; padding: 5px; width: fit-content; margin: 10px auto;"> DATE OF PURCHASE Mo. Yr. </div> <p>PLEASE PRINT THANK YOU</p>	<p>Your Name _____</p> <p>Business Name _____</p> <p>Address _____ <small>Street City State & Zip Code</small></p> <p>Telephone Number (____) _____</p> <p>E-mail Address _____</p> <p>NOTICE: Personal information collected in this card will only be used for 3M Product Registration purposes.</p>
--	--

Model # _____

Where Purchased _____

Business Address _____
Street City State & Zip Code

Equipment this system is used on _____

Model # (if known) _____ Manufacturer _____

If the filter is used on more than one machine, please list below.

Equipment	Model	Manufacturer
_____	_____	_____
_____	_____	_____

TABLE OF CONTENTS

SECTION	DESCRIPTION
1	BEFORE INSTALLATION
2	INSTALLATION
3	REGENERATION INSTRUCTIONS (Timer Setting Instructions)
4	SERVICE INSTRUCTIONS
5	SPECIFICATIONS AND OPERATING DATA
6	PARTS
7	MAINTENANCE

SECTION 1: BEFORE INSTALLATION

Before starting the installation we suggest reading this manual all the way through for an overview, and then follow the installation steps in the proper sequence. IMPROPER INSTALLATION could void the warranty. Installation should be completed by a qualified plumber.

INSPECTING AND HANDLING THE WATER SOFTENER:

Inspect the equipment for shipping damage. If damaged, notify the transportation company and request a damage inspection.

Handle the equipment with care. Damage can result if dropped or if the brine tank is set on sharp, uneven projections on the floor. When handling, do not turn the water softener unit upside down.

MAKE SURE YOUR WATER HAS BEEN THOROUGHLY TESTED:

An analysis of the water should be made prior to the selection of water conditioning equipment. The dealer will generally perform this service, and may send a sample to the factory for analysis and recommendations. Enter the analysis below for a permanent record.

IMPORTANT NOTES

Hydrogen sulfide (H₂S) must be tested for at the well site. For accuracy, the sample must be drawn with the pump RUNNING, and the test be completed within ONE minute after the sample is drawn.

Softeners are designed to remove hardness but can handle reasonable amounts of soluble iron if consideration is given to content when selecting model and regeneration settings. To treat sulfur (hydrogen sulfide), bacterial iron, precipitated iron or very high levels of soluble iron requires special equipment in addition to a water softener. For best results, a Chem-Free Iron Reduction Filter is recommended for use on waters containing more than 2 ppm of iron.

Analysis Of Your Water

CONTAMINANT	YOUR WATER
Hardness	_____gpg
Iron (Fe)	_____ppm
Manganese (Mn)	_____ppm
pH	_____
Tannins (Humic Acid)	_____ppm
Hydrogen Sulfide (H ₂ S)	_____ppm
Other_____	_____ppm
Other_____	_____ppm

SECTION 7: MAINTENANCE

REPLENISHMENT OF SALT SUPPLY:

The salt storage capacity of the brine tank is approximately 280 lbs. (127 kg). During each regeneration a specific amount of salt is consumed, thus requiring its periodic replenishment (the frequency is dependent on the regeneration schedule). Always replenish salt before the supply is exhausted to assure a continuous supply of softened water.

TYPE OF SALT TO USE:

Any type of water softener salt may be used. There are advantages and disadvantages to every type of salt. Please ask the local dealer for his advice. The unit is designed to compensate for the disadvantages.

BRINE TANK CLEAN-OUT:

To prevent service problems the brine tank should be emptied and flushed out with a garden hose when dirt and other insolubles accumulate. The clean-out frequency depends on the type salt used and regeneration frequency. The clean-out should be done when the salt level is low. Steps to follow:

- 1) Disconnect brine line at either end.
- 2) Turn brine tank upside down and discard old salt. Remove salt grid plate.
- 3) Rinse out with a garden hose.
- 4) Reconnect brine line.
- 5) Add enough water to brine tank to cover the air check in the brine well 1" before adding new salt. Perform approximately once a year if rock salt is used; with other types of salt, approximately once every other year.

PREVENTING IRON-FOULING OF MINERAL BED:

If iron is present in the water supply, the softener mineral bed will eventually become iron-fouled, resulting in reduced softening capacity and rust-stained fixtures. Mixing one to two ounces of IRON-X Mineral Cleaner with every 80 lbs. of salt added to brine tank will minimize these problems from occurring. IRON-X is available from the dealer.

PERIODICALLY CHECK TIME OF DAY SETTING:

Power outages will cause TIME OF DAY timer setting to become incorrect. To reset, refer to appropriate HOW TO SET TIME CLOCK REGENERATION CONTROL, Section 3.

MALFUNCTION OF UNIT:

The water softener, under normal conditions, should provide years of trouble-free service; however, since it is a mechanical device, it can malfunction. (Refer to Section 4, SERVICE INSTRUCTIONS, if necessary).

CHANGE OF OPERATING CONDITIONS:

Should the daily water usage, or water quality change, the regeneration program settings may have to be adjusted. Consult the dealer if any of the above occur.

CHECK WATER PRESSURE AND PUMPING RATE:

Two water system conditions must be checked carefully to avoid unsatisfactory operation or equipment damage:

- 1) MINIMUM water pressure required at the softener tank inlet is 20 psi. IF PRESSURE IS OVER 100 PSI, A PRESSURE REDUCING VALVE MUST BE INSTALLED IN THE WATER SUPPLY LINE AHEAD OF THE WATER SOFTENER.

CAUTION
<p>To reduce the risk associated with property damage due to water leakage:</p> <ul style="list-style-type: none"> • Do not install if water pressure exceeds 100 psi (689 kPa). If the system water pressure exceeds 100 psi, the installation must use a pressure limiting valve. Contact a licensed plumbing professional if you are uncertain how to check your water pressure. • Do not install system where water lines could be subjected to vacuum conditions without appropriate measures for vacuum prevention.

IMPORTANT NOTE
<p>If the source is a municipal or a community water supply and daytime water pressure is 85 psi or more, nighttime pressure may exceed 100 psi. Call the local water department or plant operator to obtain pressure readings. If the source is a private well, the gauge on the pressure tank will indicate the high and low system pressure. Record water pressure data below:</p>

WATER PRESSURE

Low _____ psi High _____ psi

- 2) If the source of water is a private well, the pumping rate of the well pump must be sufficient for satisfactory operation and BACK-WASHING of the WATER SOFTENER. (See SPECIFICATIONS AND OPERATING DATA, Section 5).

LOCATE WATER CONDITIONING EQUIPMENT CORRECTLY:

Select the location of the water softener with care. Various conditions which contribute to proper location are as follows:

- 1) Locate as close as possible to water supply source.
- 2) Locate as close as possible to a floor or other adequate drain.
- 3) Locate in correct relationship to other water conditioning equipment (Figure 1).
- 4) Temperatures above 150° F (66° C) will damage the softener and void the factory warranty.
- 5) Do NOT install the softener in a location where freezing temperatures occur. Freezing may cause permanent damage and will also void the factory warranty.
- 6) Allow sufficient space around the unit for easy servicing.
- 7) Provide a non-switched 110V, 60Hz power source for the control. (Reference transformer to verify proper power supply voltage.)

**ONLY THOSE PARTS CIRCLED IN DRAWING AND/OR LISTED BELOW ARE STOCK ITEMS
ALL OTHERS ARE SPECIAL ORDER, NON-RETURNABLE**

PARTS LIST - 12 DAY TIMER

REF.	PART NO.	DESCRIPTION
A	14381X	Skipper Wheel Assy. (Incl. Ref. Items 4-10)
B	13010XT	24-Hour Gear Assy. (Incl. Ref. Items 11-16)
C	60514-02	Brine Cam Assy. Minutes of Refill Salt (Incl. Ref. Items 30 - 34)
D	60102-031	Piston Kit (Incl. Ref. Items 41-45)
E	60125-05	Seal Kit, HW (Incl. Ref. Items 46 & 47)
F	60022-501	Brine Line Flow Control Assy., 0.50 GPM, (Incl. Ref. Items 75-78)
G	10090X	Adapter Coupling Assy. (Incl. 2 ea. Ref. Items 84-86 & 4 ea. Item 83)
H	60040	3/4" Bypass Valve, 316SS, Hot/Cold
1	22602	Valve Cover, Specify Model
25	19659	Motor, 24V/60 Hz
26	11384	Motor Mtg. & Ground Screw
28	13170	Main Gear
36	U321	Transformer, 110V/60Hz - 24V/60Hz
50	13304	Distributor Tube O-Ring
49	10381-01	Tank O-Ring
60	13361	Stand-off
61	13497	Air Disperser
62	12638-01	Drain O-Ring, HW
63	13301-01	Injector O-Ring, HW
65	10226-1	Injector Throat - Specify Size
66	10227	Injector Screen
67	10225-1	Injector Nozzle - Specify Size
68	13303-01	Injector Cover O-Ring
69	13166	Injector Cover
70	13387	Screw, Injector Mounting
71	13315	Injector Mounting Screw
72		Drain Line Flow Control Button: 4.0 GPM
73	12091	Drain Line Flow Control Retainer
74	13173	Drain Line Fitting
79	12338	Brine Line Screen
80	12767	Brine Line Tube Insert
81	10332	Brine Line Ferrule
82	10330	Brine Line Fitting Nut
83	10329	Adapter Coupling O-Ring
84	13305	Adapter Coupling
85	13709	Adapter Clip (Incl. 2 ea. Ref. Item 83)
86	13255	Adapter Coupling Screw
92	13314	Seal, Bypass
	14105	

FACTS TO REMEMBER WHILE PLANNING THE INSTALLATION:

⚠ WARNING

To reduce the risk associated with hazardous voltage:

- If the electrical system requires use of the cold water system as an electrical safety ground, a jumper must be used to ensure a sufficient ground connection across the softener installation piping — refer installation to qualified personnel.

CAUTION

To reduce the risk associated with property damage due to water leakage:

- **Installation must comply** with existing state or local plumbing codes.
- **Do not** install if water pressure exceeds 100 psi (689 kPa). If the system water pressure exceeds 100 psi, the installation **must** use a pressure limiting valve. Contact a licensed plumbing professional if you are uncertain how to check your water pressure.
- Do not install system where water lines could be subjected to vacuum conditions without appropriate measures for vacuum prevention.
- **Do not** use torches or other heat sources near plastic plumbing, as damage may occur.
- Take care when using pliers or pipe wrenches to tighten plastic fittings, as damage may occur.
- On plastic fittings, use thread sealing tape only. Never use pipe sealant or pipe dope on plastic fittings, as damage may occur.

To reduce the risk associated with property damage due to plugged water lines:

- Pay particular attention to correct orientation of control valve. Water flow should match arrow on control valve. The Inlet and Outlet of other water treatment equipment products will vary depending on the control valve brand used.

Remember that the filter **INLET** is attached to the pipe that supplies water (i.e. runs to the pump) and **OUTLET** is the line that runs toward the water heater or other water treatment equipment device.

Before commencing the installation, it is advisable to study the existing piping system and to determine the size, number and type of fittings required. Typical system schematics shown in Figure 1 will be of assistance.

**CONTROL VALVE
- 12 DAY TIMER**

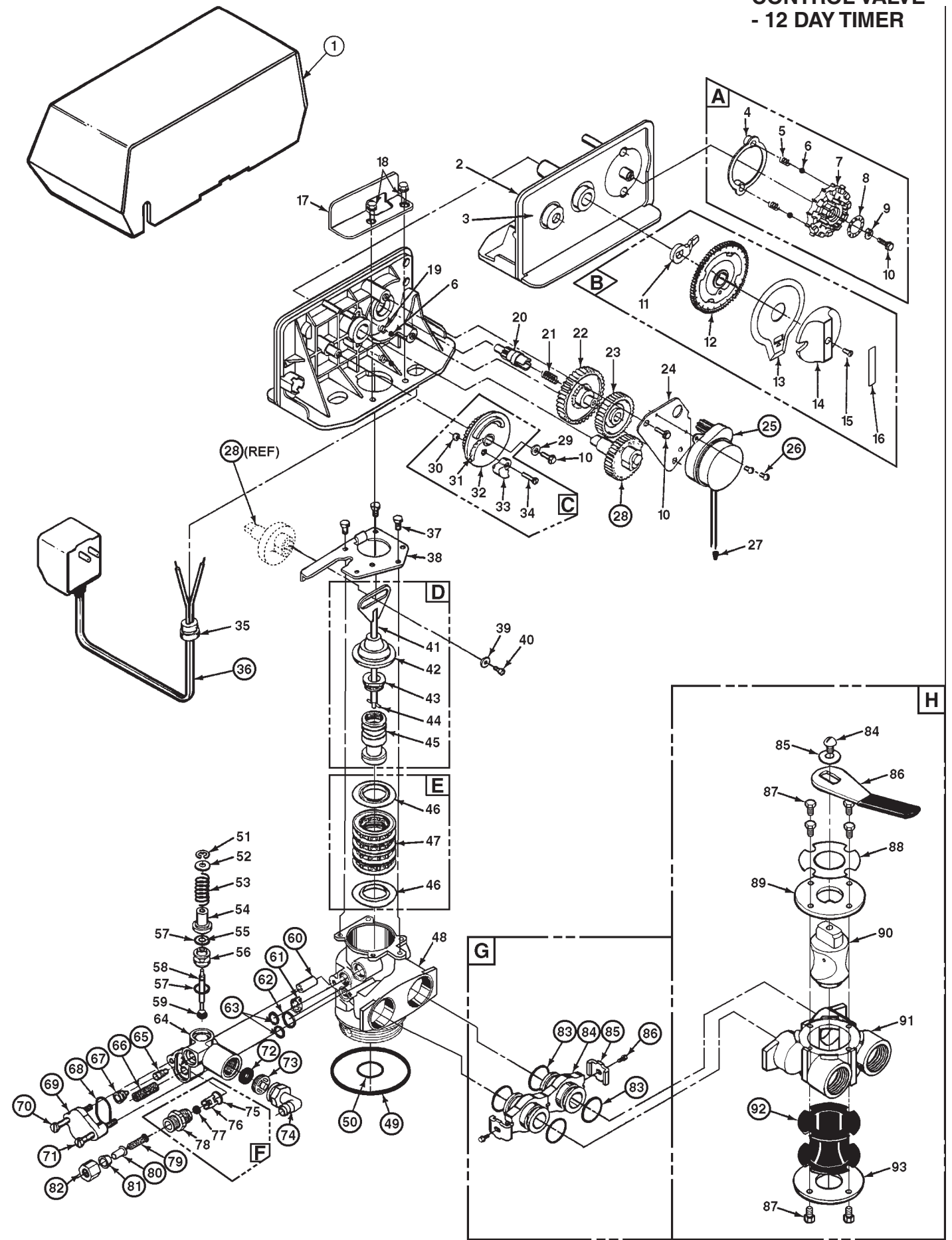

SECTION 2: INSTALLATION

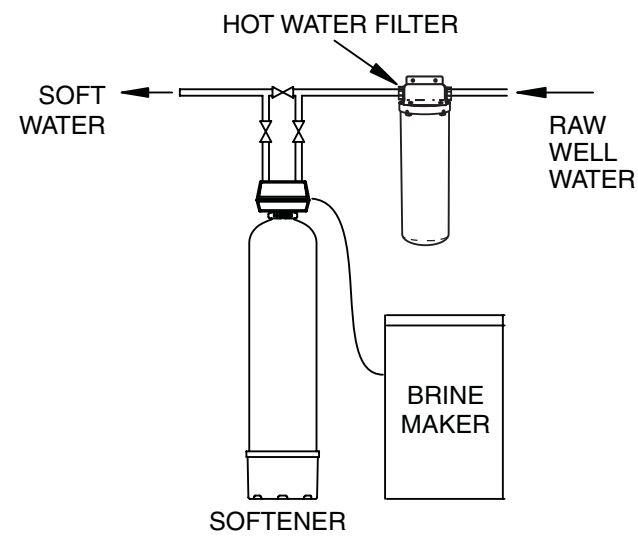

Figure 1. INSTALLATION SCHEMATIC

CAUTION

To reduce the risk associated with property damage due to water leakage:

- When water supply is shut off, shut off fuel or electric power to water heater;
- **Do not** use torches or other heat sources near plastic plumbing, as damage may occur;
- Take care when using pliers or pipe wrenches to tighten plastic fittings, as damage may occur;
- On plastic fittings, use thread sealing tape only. Never use pipe sealant or pipe dope on plastic fittings, as damage may occur;

To reduce the risk associated with property damage due to plugged water lines:

- Pay particular attention to correct orientation of control valve. Water flow should match arrow on control valve. The Inlet and Outlet of other water treatment equipment products will vary depending on the control valve brand used.

Step 1

If not factory pre-installed, attach BYPASS VALVE using ADAPTER COUPLINGS, CLIPS and SCREWS to CONTROL VALVE (Figure 2).

Step 2

Verify all packing materials have been removed from the brine tank.

Step 3

Shut off water at supply valve. On a private well system, turn off power to pump and drain pressure tank. Make certain pressure is relieved from complete system by opening nearest faucet to drain system. SHUT OFF FUEL SUPPLY TO WATER HEATER.

Step 4

Cut main supply line as required to fit plumbing to INLET and OUTLET of unit.

Step 5

Attach plumbing. DO NOT apply heat to any fitting connected to BYPASS or CONTROL VALVE as damage may result to internal parts or connecting adapters. Make certain water flow enters through inlet and discharges through outlet.

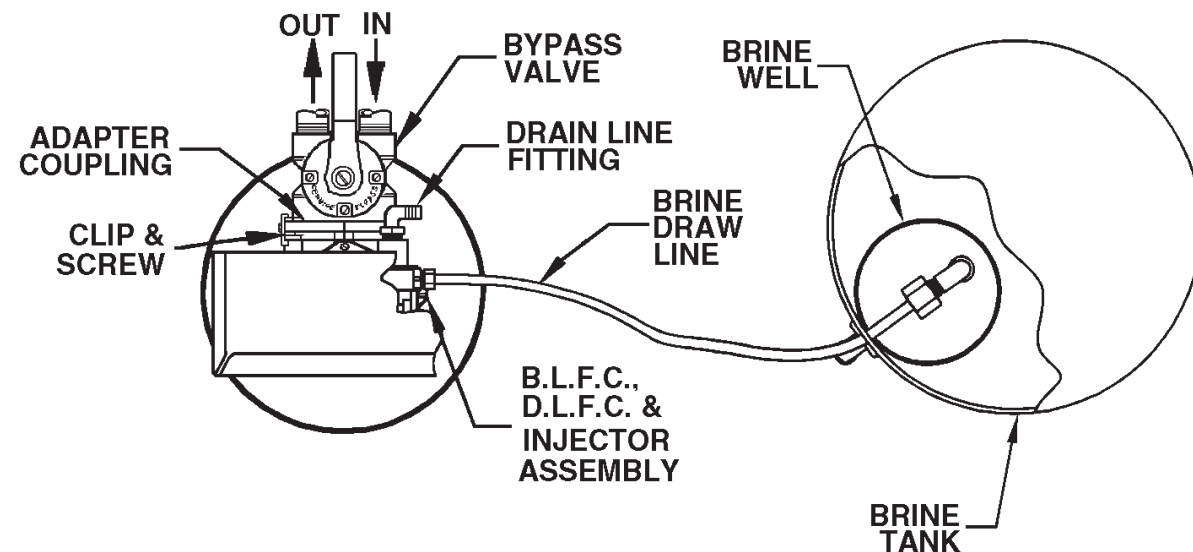

Figure 2. SOFTENER AND BRINE TANK ASSEMBLY, TOP VIEW

SECTION 6: PARTS

COMPONENT PARTS LIST

REF NO.	DESCRIPTION	HWS050	HWS100
1	Control Valve, Time Clock Initiation, with Cover, less Bypass (HWS Series)	B100407-5S1-2S	B100407-5S1-2S
2	Media Tank w/Base	MTV1019B-BLU	MTV1040B-BLU
3	Media	H-050P	H-10P
4	Distributor Assy.	60795-10	60795-10
5	Brine Line Tubing	13000X	13000X
6	Overflow Fitting	BT16	BT16
7	Brine Tank Shell w/Cover	BT1833BLU	BT1833BLU
8	Brine Well w/Cap	BTCS11-28	BTCS11-28
9	Grid Plate	Optional	Optional
10	Safety Brine Valve	60027-FFA	60027-FFA
11	Float Assembly	60028SAN	60028SAN
12	Air Check Assembly	60003	60003

NOTE: When ordering components, always specify model number.

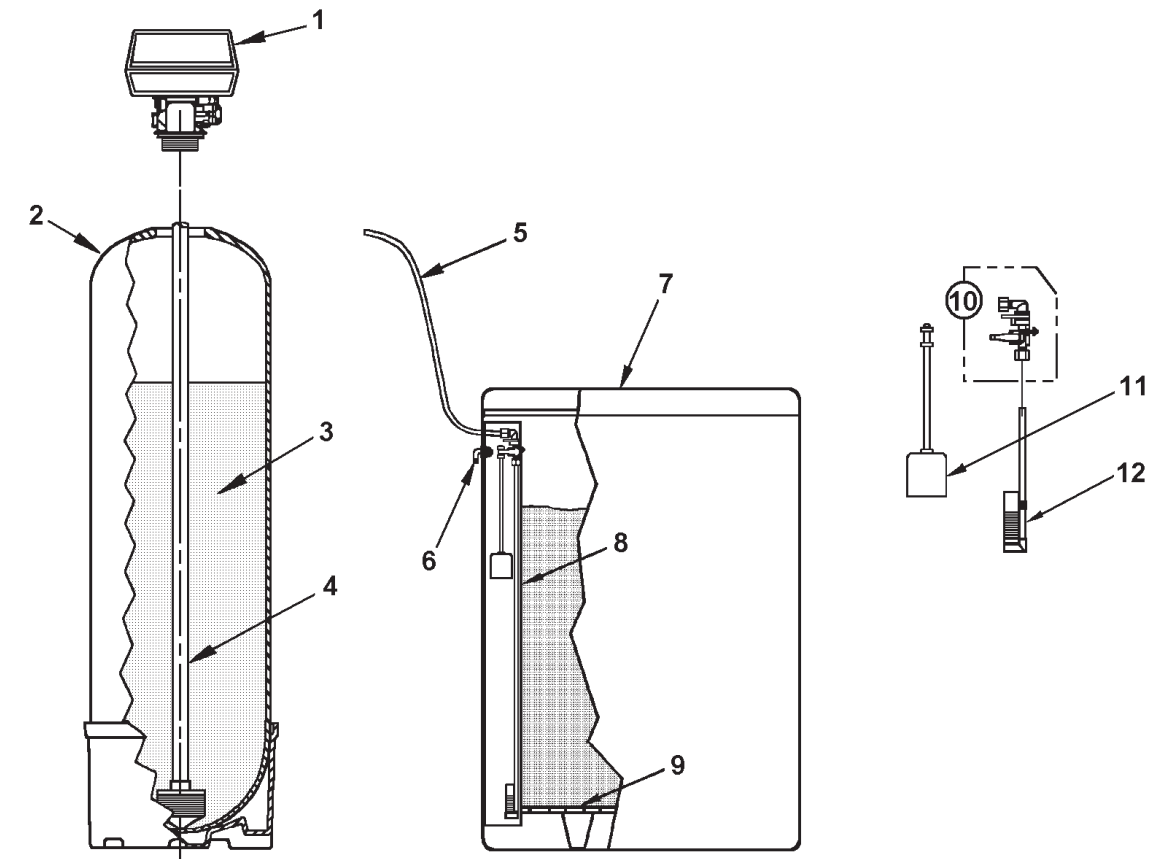

Step 6

Attach DRAIN LINE to DRAIN LINE FITTING. To prevent back pressure from reducing flow rate below minimum required for backwash, DRAIN LINE MUST be sized according to run length and relative height. Be careful not to bend flexible drain tubing sharply enough to cause "kinking" (if kinking occurs DRAIN LINE MUST BE REPLACED). Typical examples of proper DRAIN LINE diameters are:

- (1) 1/2 in. ID up to 15 ft. when discharge is lower than INLET.
- (2) 5/8 in. ID up to 15 ft. when discharge is slightly higher than INLET.
- (3) 3/4 in. ID when drain is 25 ft. away and/or drain is installed overhead.

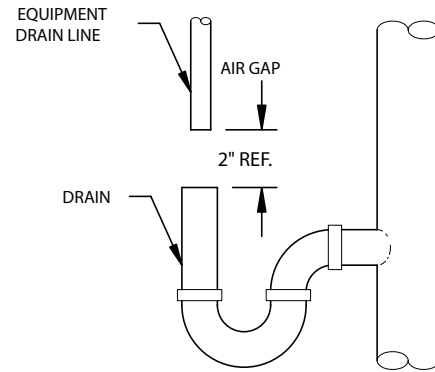

Figure 3. TYPICAL DRAIN

Step 7

Position DRAIN LINE over drain and secure firmly. To prevent backsiphoning of waste water, provide an air gap of at least 2 in. or 2 pipe diameters between end of drain hose and drain (Figure 3). **DO NOT** raise DRAIN LINE more than 10 ft. above floor.

Step 8

Connect one end of the 3/8 in. poly line to BRINE VALVE located on the right side of CONTROL VALVE. Connect other end to ELBOW inside of BRINE WELL. Brass insert sleeves and plastic ferrules must be used where necessary. (Figure 2 and CONTROL VALVE PARTS Drawing, Section 6).

Step 9

Install OVERFLOW LINE to brine tank OVERFLOW FITTING (Figure 2). Discharge of line must be lower than OVERFLOW FITTING. **DO NOT INTERCONNECT OVERFLOW LINE WITH VALVE DRAIN LINE.**

Step 10

Make certain BYPASS VALVE IS IN "BYPASS" position. After all plumbing connections have been completed, open main water shut-off valve or restore power to well pump. Check for leaks and correct as necessary.

Step 11

Manually stage control to BACKWASH POSITION by turning "MANUAL REGENERATION KNOB", clockwise to "BACKWASH" position, refer to HOW TO SET TIME CLOCK REGENERATION CONTROL (Section 3).

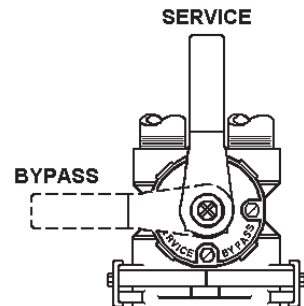

Figure 4. BYPASS VALVE

Step 12

Partially open (approximately 1/4 of the way) the INLET valve in plumbing or BYPASS VALVE (Figure 4). This will allow the unit to fill slowly from the bottom up, eliminating air entrapment. Allow unit to fill slowly, failure to do so could result in loss of resin to the drain. Once a steady stream of water, no air, is flowing to drain, the INLET OR BYPASS VALVE can be fully opened. Manually advance control to SERVICE POSITION. Plug transformer into a non-switched 110V, 60Hz power source. (Reference transformer to verify proper power supply voltage.)

Step 13

Set REGENERATION FREQUENCY. Refer to REGENERATION FREQUENCY SCHEDULES (Section 3) to determine correct frequency, then refer to HOW TO SET TIME CLOCK REGENERATION CONTROL (Section 3) for instructions on setting frequency.

IMPORTANT NOTE

Regeneration settings are factory **preset** for the most efficient salt use and minimum water consumption used for regeneration (as little as 50 gallons). REGENERATION FREQUENCY SCHEDULES are designed for use with factory regeneration settings (listed in SPECIFICATIONS AND OPERATING DATA, Section 5).

The control valve design permits adjustment of the salt dosage. This adjustment may be necessary when unusual operating conditions exist, such as high concentrations of iron or hardness and/or high flow rates or daily water consumption. This adjustment is easily performed by loosening the screw holding the white cam (on backside of timer) and adjusting the pointer to the desired refill time. Refill rate is controlled by a flow control to 0.5 gpm. By adjusting the amount of time the unit is allowed to refill the brine tank, the salt dosage can be adjusted. Each gallon of fresh water added to the brine tank will dissolve 3 lbs. of salt.

EXAMPLE: If a salt dosage of 6 lbs. is desired, the salt refill time should be set to 4 minutes.

4 minutes x 0.5 gpm = 2 gals.

2 gals. x 3 lbs/gal = 6 lbs.

SECTION 5 : SPECIFICATIONS AND OPERATING DATA

TIMER INITIATED MODELS:

ITEM	HWS050	HWS100
Nominal Media Volume, cu. ft. (cu. mtr.)	0.50 (0.02)	1.0 (0.03)
Salt dosage, lbs. (kg): Factory Setting Maximum Setting	3.0 (1.4) 6.0 (2.7)	6.0 (2.7) 15.0 (6.8)
Nominal Softening Capacity, grains (grams): (1) At factory salt setting At maximum salt setting	13,000 (842) 16,000 (1057)	18,600(1205) 30,000(1944)
Operating Flow Rates, gpm (lpm): (2) Service (10 minutes or less)	5.0 (18.4)	8.5 (32.2)
Pressure Loss @ Operating Flow Rates, psi (kPa): Service	2.0 (14)	6.0 (42)
Regeneration Flow Rates, gpm (lpm): Backwash (3) Brine/Rinse Rapid Rinse Brine Refill	4.0 (15.1) 0.6 (2.3) 4.0 (15.1) 0.5 (1.9)	4.0 (15.1) 0.6 (2.3) 4.0 (15.1) 0.5 (1.9)
Inlet/Outlet Pipe Size, in. (cm)	3/4" FPT (1.9)	3/4" FPT (1.9)
Mineral Tank Dia. x Height, in. (cm)	10x19 (40x76)	10x40 (40x160)
Overall Depth & Height w/Control Valve, in. (cm)	10x28 (25x112)	10x49 (40x196)
Brine Tank, W x D x H, in. (cm)	18x26 (46x66)	18x26 (46x66)
Approx. Salt Storage, lbs. (kg)	280 (127)	280 (127)
Approx. Shipping Weight, lbs. (kg)	65 (30)	100 (45)

Maximum operating temperature 150° F (66° C); Electrical requirements 110V/60Hz (220V/50Hz); Operating pressure 20-100 psi (138 - 689 kPa). All types water softener salt may be used (See MAINTENANCE). Specifications subject to change without notice.

NOTES:

- 1) Actual capacity may vary substantially depending on water analysis and operating conditions.
- 2) For satisfactory performance indicated flow rates and duration should not be exceeded. Flow rates specified are adequate for normal applications.
- 3) For system to operate properly, pumping rate of well pump (if applicable) MUST be sufficient to backwash unit at rate specified.

Step 14

Set TIME OF DAY (refer to appropriate HOW TO SET TIME CLOCK REGENERATION CONTROL, Section 3). When shifting to daylight saving time (and back), you may wish to adjust TIME OF DAY accordingly.

IMPORTANT NOTE

TIME OF REGENERATION is pre-set for 2:00 a.m. because at this time water consumption is generally minimal (a built-in hard water bypass does, however, permit water to be drawn during regeneration). Should the application require **regular** use of water during the 2:00 to 3:00 a.m. regeneration period, or if other water treatment equipment is also set for 2:00 a.m. regeneration, the TIME OF REGENERATION will need changing. To change, adjust time of day on 24-HOUR GEAR ahead or behind actual time of day. For example, if 1:00 a.m. regeneration is desired and actual time of day is 10:00 a.m., **advance** 24-HOUR GEAR one hour to 11:00 a.m.; or, should 3:00 a.m. regeneration be desired, set gear **back** one hour to 9:00 a.m.

Step 15

Before loading salt, using a pail or garden hose, add enough water to brine tank to cover the air check in the brine well by approx. one (1) inch. Then add initial salt fill to brine tank, and one cup full of unscented laundry bleach to brine well.

Step 16

RESTORE FUEL SUPPLY OR POWER TO WATER HEATER. Put softener through complete regeneration to sanitize the system before use (Refer to HOW TO SET TIME CLOCK REGENERATION CONTROL for instructions on manual regeneration).

Installation is now complete, and the water softener is now ready for service!

SECTION 4: SERVICE INSTRUCTIONS

Problem	Cause	Solution
1. Hard water (unit not using salt; liquid level in brine tank NOT too high)	A. Electrical service to unit interrupted	A. Assure permanent electrical service (check fuse, plug, pull chain, or switch)
	B. Timer not working.	B. Replace timer motor .
	C. Timer improperly set	C. Increase frequency of regeneration and/or salt setting.
	D. Safety brine valve not opening	D. Replace safety brine valve
	E. Salt "bridged" in brine tank	E. Breakup salt
2. Hard water (unit using salt; liquid level in brine tank NOT too high)	A. Bypass open	A. Close bypass (replace if necessary)
	B. Timer improperly set	B. Increase frequency of regeneration or reset timer if needed.
	C. No salt in brine tank	C. Add salt; maintain above water level
	D. Excessive water usage	D. Increase frequency of regeneration and/or salt setting (See HOW TO SET TIMER)
	E. Unit installed backwards	E. Reinstall unit
	F. Unit undersized	F. Replace with larger unit
3. Liquid level in brine tank TOO high	A. Brine valve not closing	A. Replace brine valve
	B. Salt setting too high	B. Reset timer
	C. Injector or Injector screen plugged	C. Clean injector and screen
	D. Drain line frozen, plugged or restricted	D. Free drain
	E. Salt "mushed" or sand from salt plugging bottom of brine tank	E. Clean out brine tank (see instructions)
	F. Incorrect brine line flow control (BLFC)	F. Replace with correct flow control (see specifications)
4. System regenerates at wrong time of day	A. Power outage occurred.	A. Reset timer
5. Water continuously flows to drain	A. Foreign material in control valve	A. Remove piston assembly and inspect bore: remove foreign material and check control in various regeneration positions
	B. Internal control leak	B. Replace seals and/or piston assembly
	C. Control valve jammed in brine or backwash position	C. Replace piston, seals and spacers
6. Water tastes salty	A. Salt setting too high	A. Reset program cycle
	B. Distributor tube too short	B. Replace
7. White spots on glassware and dark surfaces	A. Sodium residual resulting from water having very high hardness or total dissolved solids (TDS)	A. Installation of additional water treatment equipment such as reverse osmosis or demineralization
8. Low water pressure (low flow rate)	A. Iron build-up in line to water conditioner	A. Clean line to water conditioner
	B. Iron build-up in water conditioner	B. Clean control and add Iron-X Mineral Cleaner to resin bed: increase frequency of regeneration
	C. Well pumping sand	C. Install sand trap
	D. Pump losing capacity	D. Contact pump repair service
9. "Rotten egg" smell (from hot water only)	A. Magnesium rod in water heater	A. Replace with aluminum rod or remove
10. "Rotten egg" smell (from both hot and cold water)	A. Hydrogen sulfide ("sulfur") in water supply	A. Install Sul-X Sulfur Reduction System
	B. Bacterial iron in water supply	B. Install Chem-Free Iron Reduction System
	C. Algae in water supply	C. Pour approximately 1/2 cup laundry bleach into brine well just before regeneration as frequently as necessary
11 Loss of resin through drain	A. Air in water system	A. Assure that well system has proper air eliminator control: check for dry well condition
	B. Incorrect Drain Line Flow Control (DLFC).	B. Replace with correct DLFC.
	C. Unit regenerating with cold water.	C. Reinstall so unit uses hot water for regeneration.

SECTION 3: REGENERATION INSTRUCTIONS

INSTRUCTIONS FOR USING REGENERATION FREQUENCY SCHEDULES:

- 1) Determine ADJUSTED HARDNESS by adding three (3) times the iron content in parts per million (ppm) to the hardness in grains per gallon (gpg). The resulting number is ADJUSTED HARDNESS.

EXAMPLE: Hardness is 14 gpg and iron is 2 ppm. ADJUSTED HARDNESS is 20 gpg (14 plus 3 times 2).

- 2) Select REGENERATION FREQUENCY SCHEDULE corresponding to the model. Locate box intersected by DAILY WATER USE and ADJUSTED HARDNESS (if ADJUSTED HARDNESS is between two numbers in schedule, use higher number). Number in box represents FREQUENCY or NUMBER OF times per 12 DAYS timer should be set to regenerate. Refer to HOW TO SET TIME CLOCK REGENERATION CONTROL to set correct frequency.

EXAMPLE: Rounding is always down. You have Model HWS050 (13,000 grain capacity at factory salt setting), 450 gpd usage and 5 gpg adjusted hardness. Refer to appropriate REGENERATION FREQUENCY SCHEDULE and locate box intersected by 450 gpd and 5 gpg adjusted hardness. The figure "3" in box indicates a REGENERATION frequency of THREE TIMES PER 12 DAYS (if a "1", "2", "4", etc. were in box, frequencies of once, twice and four times per twelve days, respectively, would be indicated.) This can be calculated as $13,000 / (5 \times 450) = 5.8$ days between regeneration, rounding down to every 4 days or 3 times in a 12 day cycle, as indicated.

REGENERATION FREQUENCY SCHEDULES (TIMES PER 12 DAYS)

MODEL: HWS050

Gallons Per Day	HARDNESS - GPG							
	5	10	15	20	25	30	35	40
50	1	1	1	1	2	2	2	2
100	1	1	2	2	3	3	3	4
150	1	2	2	3	4	4	6	6
200	1	2	3	4	4	6	6	6
250	2	3	4	4	6	6	12	12
300	2	3	4	6	6	12	12	12
350	2	3	6	6	12	12	12	NR
400	2	4	6	6	12	12	NR	NR
450	2	4	6	12	12	NR	NR	NR
500	3	4	6	12	12	NR	NR	NR

MODEL: HWS100

Gallons Per Day	HARDNESS - GPG							
	5	10	15	20	25	30	35	40
50	1	1	1	1	1	1	2	2
100	1	1	1	2	2	2	2	3
150	1	1	2	2	3	3	3	4
200	1	2	2	3	3	4	4	4
250	1	2	3	3	4	4	6	6
300	1	2	3	4	4	6	6	6
350	2	2	3	4	6	6	6	12
400	2	3	4	4	6	6	12	12
450	2	3	4	6	6	12	12	12
500	2	3	4	6	6	12	12	NR

NR - Not Recommended

HOW TO SET TIME CLOCK REGENERATION CONTROL

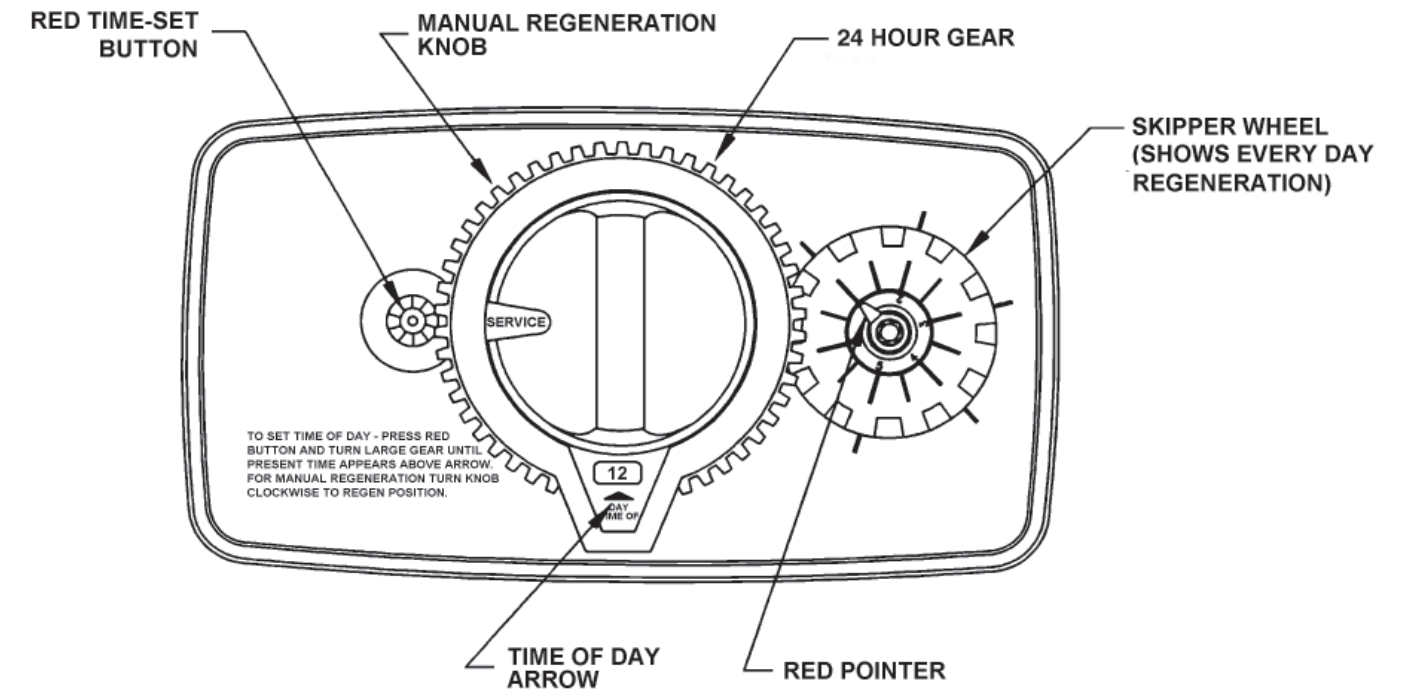

HOW TO SET DAYS ON WHICH WATER SOFTENER IS TO REGENERATE:

Rotate the skipper wheel until the number "1" is at the red pointer. Set the days that regeneration is to occur by sliding tabs on the skipper wheel outward to expose trip fingers. Each tab is one day. Finger at red pointer is tonight. Moving clockwise from the red pointer, extend or retract fingers to obtain the desired regeneration schedule.

HOW TO SET THE TIME OF DAY:

- 1) Press and hold the red button in to disengage the drive gear.
- 2) Turn the large gear until the actual time of day is opposite the time of day pointer.
- 3) Release the red button to again engage the drive gear.
- 4) Time of regeneration is preset for 2:00 a.m.

HOW TO MANUALLY REGENERATE THE WATER SOFTENER AT ANY TIME.

Turn the manual regeneration knob clockwise.

A slight, clockwise movement of the manual regeneration knob engages the program wheel and starts the regeneration program.

The black center knob will make one revolution in the following approximately three hours and stop in the position shown in the drawing (SERVICE POSITION).

Even though it takes three hours for this center knob to complete one revolution, the regeneration cycle of the unit might be set only one-third of this time.

In any event, conditioned water may be drawn after rinse water stops flowing from the water softener drain line.