



IMPORTANT FOR FUTURE REFERENCE Please complete this information and retain this manual for the life of the equipment:
Model #: _____
Serial #: _____
Date Purchased: _____

Installation & Operation Manual

Steam Coil Cabinet Base Convection Steamers SCX-16 & SCX-24



Model SCX-16

WARNING

Improper installation, adjustment, alteration, service or maintenance can cause property damage, injury or death. Read the installation, operating and maintenance instructions thoroughly before installing or servicing this equipment.

CROWN FOOD SERVICE EQUIPMENT

 A Middleby Company

70 Oakdale Road, Downsview (Toronto) Ontario, Canada, M3N 1V9

Telephone: 919-762-1000



www.crownsteamgroup.com



SAFETY PRECAUTIONS

Before installing and operating this equipment, be sure everyone involved in its operation is fully trained and aware of precautions. Accidents and problems can be caused by failure to follow fundamental rules and precautions.

The following symbols, found throughout this manual, alert you to potentially dangerous conditions to the operator, service personnel, or to the equipment.

 DANGER	This symbol warns of immediate hazards that will result in severe injury or death.
 WARNING	This symbol refers to a potential hazard or unsafe practice that could result in injury or death.
 CAUTION	This symbol refers to a potential hazard or unsafe practice that could result in injury, product damage, or property damage.
NOTICE	This symbol refers to information that needs special attention or must be fully understood, even though not dangerous.

IMPORTANT NOTES FOR INSTALLATION AND OPERATION

WARNING

This is the safety alert symbol. It is used to alert you to potential personal injury hazards. Obey all safety messages that follow this symbol to avoid possible injury or death.

WARNING

Improper installation, operation, adjustment, alteration, service or maintenance can cause property damage, injury or death. Read the installation, operating and maintenance instructions thoroughly before installing, operating or servicing this equipment.

CAUTION

Operating, testing, and servicing should only be performed by qualified personnel.

NOTICE

Contact the factory, the factory representative or local service company to perform maintenance and repairs.

NOTICE

Do Not attempt to operate this unit in the event of power failure.

NOTICE

This product is intended for commercial use only. NOT FOR HOUSEHOLD USE.

NOTICE

This manual should be retained for future reference.

It is recommended that this manual be read thoroughly and that all instructions be followed carefully.

Copyright © 2022 by Crown. All rights reserved. Published in the United States of America.

RETAIN THIS MANUAL FOR FUTURE REFERENCE.

Table of Contents

Important Notes For Installation and Operation	2
Service Connections	4
Introduction	6
Installation Instructions	7
Information to Steam Fitter	9
Operation	11
Periodic Maintenance	13
Cleaning.....	15
Adjustments	16
Troubleshooting	17

SERVICE CONNECTIONS

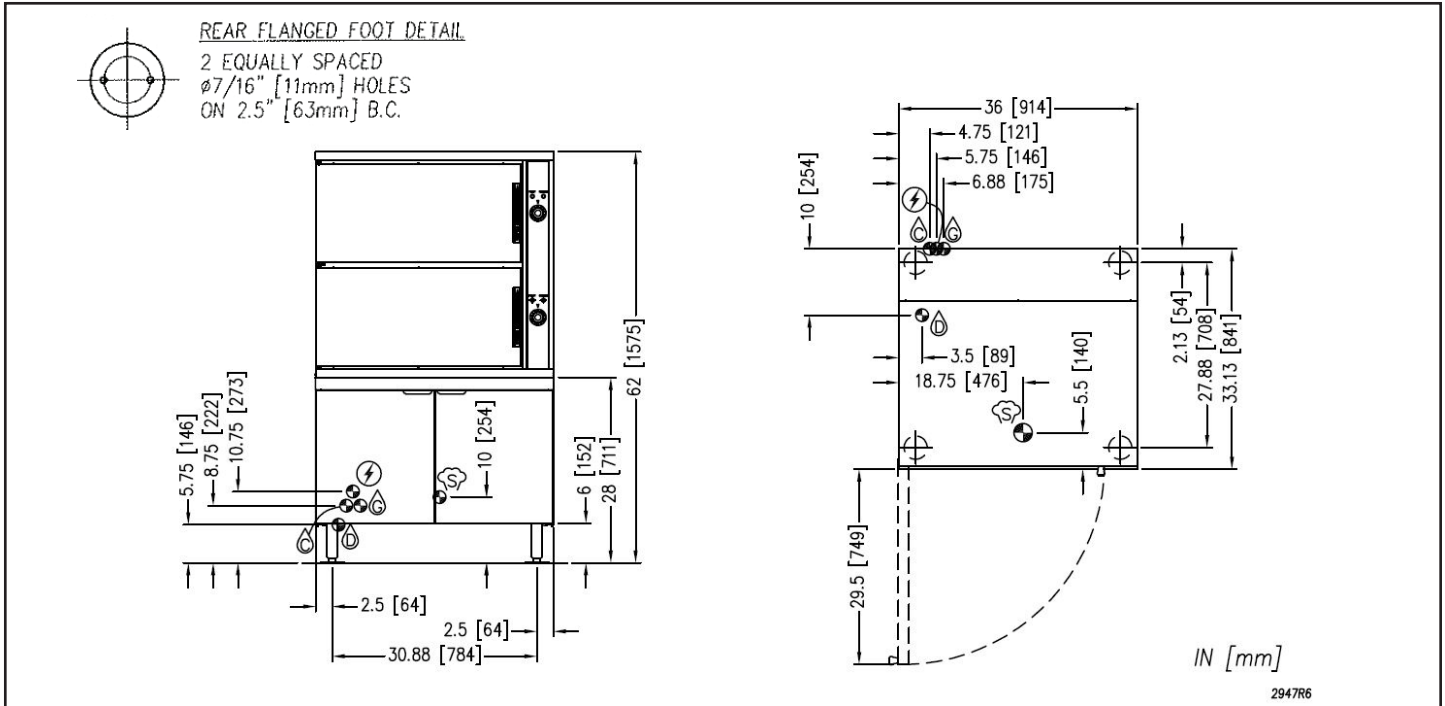

SERVICE CONNECTIONS

- Ⓒ – COLD WATER: 3/8" O.D. tubing at 25-50 PSI (170-345 kPa).
- Ⓓ – DRAIN: 2" (51 mm) IPS piped to open floor drain. No solid connection.
- Ⓔ – ELECTRICAL CONNECTION: 1/2" (13 mm) conduit connection to controls. 2 Amps per compartment, 120-60-1 or 220-50-1.
- Ⓕ – STEAM SUPPLY: 3/4" IPS at 25-45 PSI (170-310 kPa)*

* Pressure reducing valve required if incoming pressure exceeds 50 PSI (345 kPa)

COMPARTMENT PAN CAPACITY, WEIGHT AND CLEARANCE

MODEL	PAN DEPTH				
	1"	2-1/2"	4"	4" & 1"	4" & 2-1/2"
SCX-16	16	8	4	2 x 4" 2 x 1"	2 x 4" 1 x 2-1/2"

MODEL	SHIPPING WEIGHT (36" CABINET)	MINIMUM CLEARANCE	
		SIDES	BACK
SCX-16	800 lbs. [363 kg]	0	0

WATER QUALITY STATEMENT

Water is the essential ingredient in steam equipment, water quality is the major factor affecting the performance of your appliance. Crown Steam Group offers a Comprehensive Water Treatment System which exceeds our minimum water requirements. Proof of installation and proper cartridges replacement is required for warranty coverage. Water supply to Crown Steam Group steamers must be within these guidelines.

Total dissolved solids.....	Less than 60 PPM	Chlorine	Less than 1.5 PPM
Total alkalinity	Less than 20 PPM	pH Factor	6.8 - 7.3
Silica.....	Less than 13 PPM		

Water which does not meet these standards should be treated with the installation of Middleby's Water Treatment System. Call 919-762-1000 if you have questions concerning your water meeting these parameters.

*Failure or malfunction of this appliance due to poor water quality is not covered under warranty.

Reference www.crownsteamgroup.com for complete warranty details and instructions.

DISCLAIMER

Terry System Cartridge Changes / Installation – "2-3 gallons of water MUST be purged at each cartridge change or new installation prior to water supply being fed to the steamer. Failure to do so can result in component damage within the steamer which is not covered under warranty. For additional guidance on proper installation, refer to install documentation provided with each Terry System and Replacement Cartridge Set."

As continued product improvement is a policy of Crown, specifications are subject to change without notice.

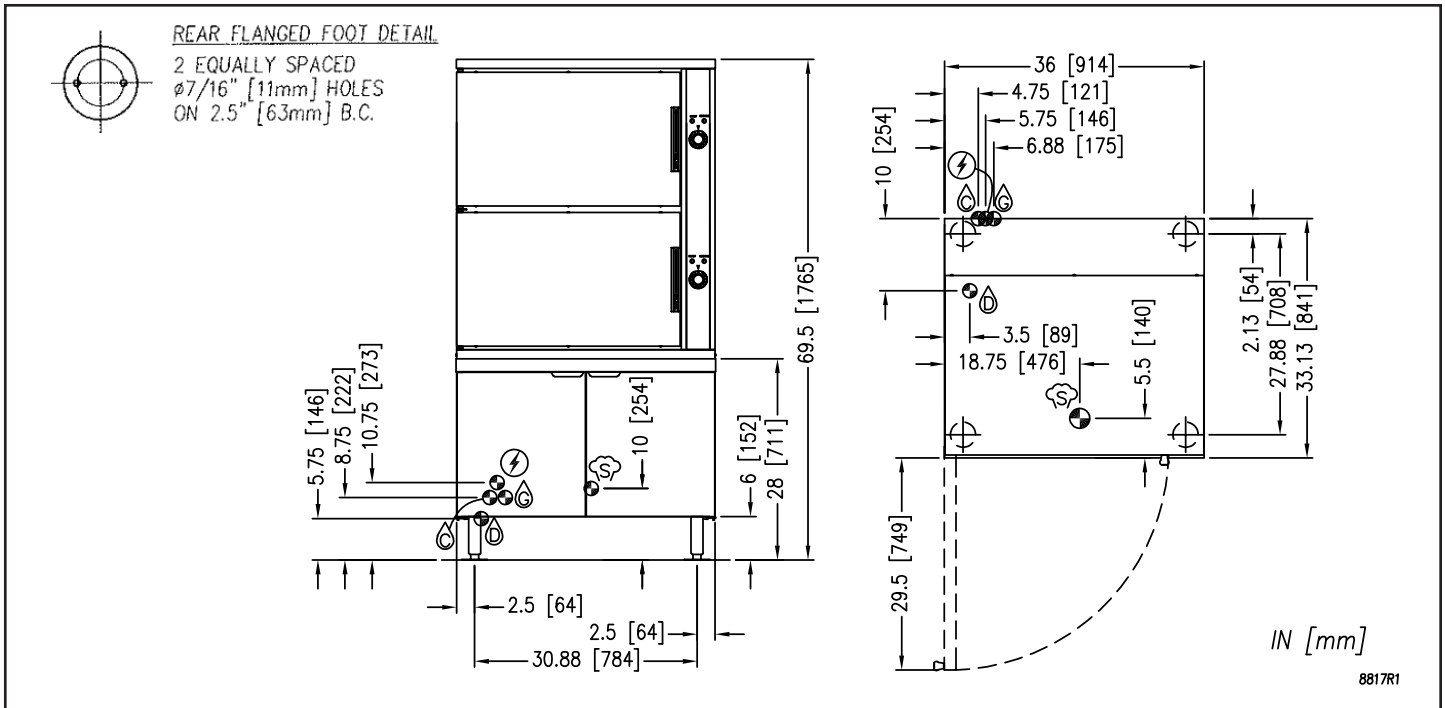

SERVICE CONNECTIONS

- ⚡ – ELECTRICAL CONNECTION: 1/2" (13 mm) conduit connection to controls. 2 Amps per compartment, 120-60-1 or 220-50-1.
- ⊕ – BOILER FEED WATER: COLD WATER: 1/2" NPT, 25-50 psi (170-345 kPa).
- ⊖ – CONDENSATE: COLD WATER: 1/2" NPT, 25-50 psi (170-345 kPa).
- ⊙ – STEAM TAKE-OFF CONNECTION: 3/4" (19 mm) optional to operate adjacent equipment.
- ⊕ – DRAIN: 2" (51 mm) IPS piped to open floor drain. No solid connection.

* Pressure reducing valve required if incoming pressure exceeds 45 PSI (310 kPa)

COMPARTMENT PAN CAPACITY, WEIGHT AND CLEARANCE

MODEL	PAN DEPTH				
	1"	2-1/2"	4"	4" & 1"	4" & 2-1/2"
SCX-24	24	12	8	4 x 4" 12 x 1"	4 x 4" 2 x 2-1/2"

MODEL	SHIPPING WEIGHT (36" CABINET)	MINIMUM CLEARANCE	
		SIDES	BACK
SCX-24	850 lbs. [386 kg]	0	0

WATER QUALITY STATEMENT

Water is the essential ingredient in steam equipment, water quality is the major factor affecting the performance of your appliance. Crown Steam Group offers a Comprehensive Water Treatment System which exceeds our minimum water requirements. Proof of installation and proper cartridges replacement is required for warranty coverage. Water supply to Crown Steam Group steamers must be within these guidelines.

Total dissolved solids.....	Less than 60 PPM	Chlorine	Less than 1.5 PPM
Total alkalinity	Less than 20 PPM	pH Factor	6.8 - 7.3
Silica.....	Less than 13 PPM		

Water which does not meet these standards should be treated with the installation of Middleby's Water Treatment System. Call 919-762-1000 if you have questions concerning your water meeting these parameters.

*Failure or malfunction of this appliance due to poor water quality is not covered under warranty.

Reference www.crownsteamgroup.com for complete warranty details and instructions.

DISCLAIMER

Terry System Cartridge Changes / Installation – "2-3 gallons of water MUST be purged at each cartridge change or new installation prior to water supply being fed to the steamer. Failure to do so can result in component damage within the steamer which is not covered under warranty. For additional guidance on proper installation, refer to install documentation provided with each Terry System and Replacement Cartridge Set."

As continued product improvement is a policy of Crown, specifications are subject to change without notice.

INTRODUCTION

DESCRIPTION

Models SCX-16 and SCX-24, convection steamers mounted on 36" cabinet base and a steam coil boiler, designed to ASME Code and approved as a steam boiler restricted to operation at pressure not to exceed 15 psi. SCX-16 steamer has a pan capacity of 16 (2 1/2") pans.

SCX-24 steamer has a pan capacity of 24 (2 1/2") pans.

BASIC FUNCTION

The sequence of operation is as follows:

1. Turn on the main power switch. A green pilot light will indicate main power is on and steam generating will begin. In approximately 20 minutes, sufficient amount of pressurized steam will have been generated in the heat exchanger and the READY pilot light will come on. OFF shuts off the steam supply to the boiler and opens the automatic blowdown valve, if so equipped, emptying the boiler and releasing water and steam to the drain. The manual blowdown valve will have to be opened to drain if not equipped with automatic blowdown valve.
2. Boiler pressure gauge should read 9 - 11 psi during operation, 0 psi during shutdown.
3. The compartment cooker is ready for use when the READY light is on. Place pans of food to be cooked into compartment(s) and close door(s).
4. Set timer(s) to cook time desired. Cooking will commence and cooking time may be interrupted at any time by opening door(s) and resumed again by closing door(s).
5. The buzzer will sound indicating the end of the cooking cycle and that steam has stopped entering the compartment(s). The COOKING pilot will go off and the READY light will come on. Turn the timer(s) to the OFF position to stop the buzzer.

INSTALLATION INSTRUCTIONS

GENERAL

The steam boiler is designed to ASME Code and approved as a steam heating boiler restricted to operation at pressure not to exceed 15 psi.

UNPACKING

IMMEDIATELY INSPECT FOR SHIPPING DAMAGE

Immediately after unpacking, check for possible shipping damage. If the appliance is found to be damaged, save the packaging material and contact the carrier within 15 days of delivery.

We cannot assume responsibility for damage or loss incurred in transit.

Before installing, verify the electrical rating agrees with the specification on the rating plate.

LOCATION

Position the appliance in its installation location. Check that there are sufficient clearances to service the controls, door swing, etc. Also adequate clearance must be left for making the required supply and drain connections.

Allow enough space between any other piece of equipment or wall for service access. Service to the controls may be required on the left and/or right side panels of the cabinet.

INSTALLATION CODES AND STANDARDS

The appliance must be installed in accordance with:

In Canada:

Provincial and local codes, or in the absence of local codes, with the Canadian Electric Code, CSA C22.1 (latest edition). Copies may be obtained from the Canadian Standards Association, 178 Rexdale Blvd., Etobicoke, Ontario, Canada, M9W 1R3.

In the U.S.A.:

State and local codes, or in the absence of local codes, with the National Electrical Code, ANSI/NFPA-70 (latest edition). Copies may be obtained from The National Fire Protection Association, Batterymarch Park, Quincy, MA, USA, 02269.

LEVELLING AND ANCHORING THE CABINET

1. Place appliance in the installation position.
2. Place a carpenter's level on top of the appliance and turn the adjustable feet to level side-to-side and front-to-back.
3. Mark hole locations on the floor through the anchoring holes provided in the flanged adjustable feet.
4. Remove appliance from installation position and drill holes in locations marked on the floor. (See *Installation Diagram* on page 4.) Insert proper anchoring devices (not supplied).
5. Place appliance back in the installation position.
6. Place carpenter's level on top appliance and re-level side-to-side and front-to-back.
7. Bolt and anchor appliance securely to the floor.
8. Seal bolts and flanged feet with silastic or equivalent compound.

ELECTRICAL CONNECTIONS

 **WARNING**

Electrical and grounding connections must comply with the applicable portions of the National Electrical Code and/or other local electrical codes.

 **WARNING**

Disconnect electrical power supply and place a tag at the disconnect switch to indicate you are working on the circuit.

When making electrical connections, use copper wire suitable for at least 200 °F (90 °C). The steamer must be grounded in accordance with the National Electrical Code or applicable local codes. The wiring diagram is located on the inside of the right panel.

EXHAUST HOOD

An exhaust system should be located directly above the boiler to exhaust steam and heat generated by the appliance.

INFORMATION TO STEAM FITTER

1. Assuming availability of 30 psi supply steam pressure immediately to the appliance, then pipe sizes of 1/2" or 3/4" or 1" will deliver respectively 90, 165 or 385 lbs. of steam per hour to the appliance Heat Exchanger. From the foregoing to use 1/2" pipe line would most likely prove inadequate.

An extremely important consideration is the pressure drop that will occur through the steam supply line from its point of origin to the appliance. The greater the length of piping and number of valves and elbows, the greater will be the pressure losses.

Consider a pressure drop of 1 (one) psi for each straight length of pipe equivalent to 120 diameters of that pipe. Thus, a 1" pipe having a straight length of 120" (10 feet) is equivalent to 120 diameters of that pipe and will have a pressure loss of 1 psi through that pipe.

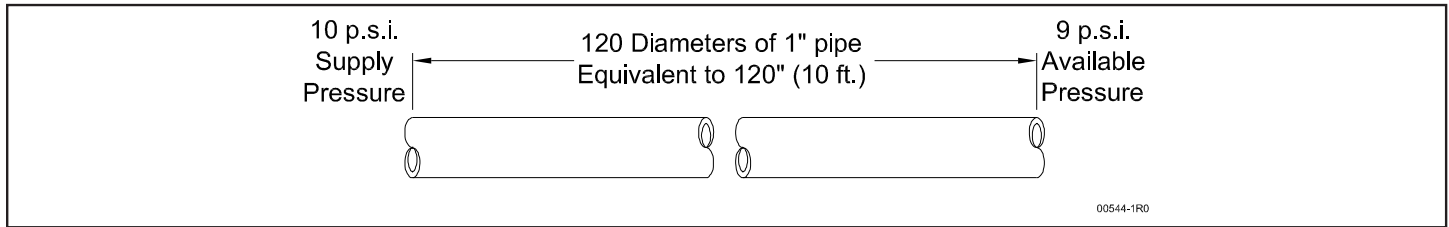

NOTE: In 3/4" pipe size, that a Standard 90° Elbow and Angle Valve and a Globe Valve are equivalent to 1.8 feet, 10 feet and 18 feet respectively of straight pipe.

Similarly, in a 1" pipe size, a standard 90° Elbow and Angle Valve and a Globe Valve are equivalent to 2.2 feet, 12 feet and 23 feet respectively of straight pipe.

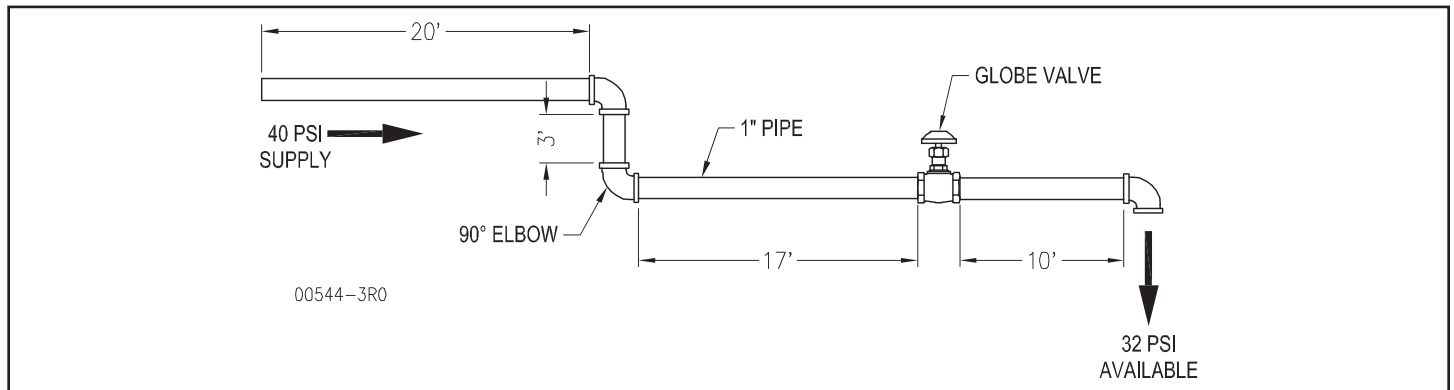

Total of above = 20 + 2.2 + 3 + 2.2 + 17 + 23 + 10 + 2.2 = 79.6 feet. Since each 10 feet is equivalent to 1 psi pressure loss, 79.6 feet is equivalent to approximately 32 psi from an original Boiler supply of 40 psi.

It is suggested that, wherever possible, the steam supply line to the appliance is a separate line from the steam source. If the appliance must be supplied from a line supplying other appliances, the pipe sizes and pressure will have to be verified. Further, during idle periods, when the steam in the supply line is not in use, water will form from condensed steam in the supply line. It is advisable to prevent water pockets from forming in the steam line and impeding the steam flow when it is required. Therefore, the steam supply line should be installed level or run slightly downwards towards the appliance. Install a Ball Float Trap near the appliance to drain out water (condensed steam) from the line to assure clean dry steam to the appliance.

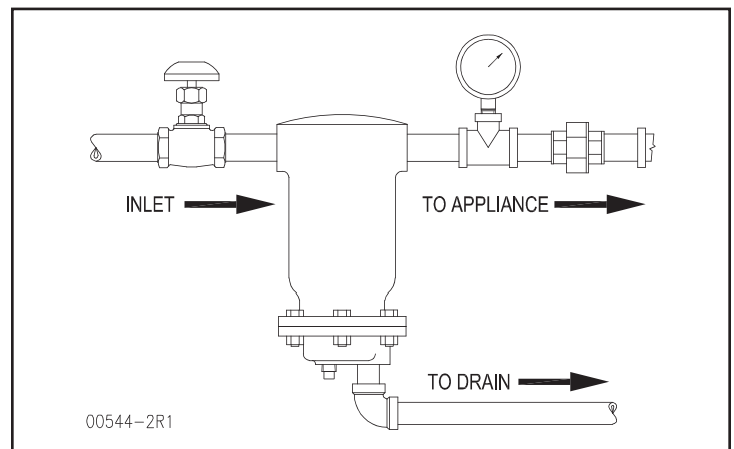

PLUMBING CONNECTIONS (SEE *SERVICE CONNECTIONS* SECTION)

 **WARNING**

Plumbing connections must comply with applicable sanitary, safety, and plumbing codes.

Water Supply Connection

The incoming cold water supply connection, at the rear of the boiler cabinet, requires 3/8" tubing and water pressure of 25 - 50 psig. A manual shut-off valve must be provided convenient to the appliance, this valve should be open when the boiler is in operation.

 **WARNING**

If your equipment was supplied with split water lines and a water treatment system, connect the system to the connection marked "FILTERED WATER IN" only (Use cold water). Make a second connection to the "CONDENSER WATER IN" from a cold and unfiltered water supply.

NOTICE

FAILURE OR MALFUNCTION OF THIS APPLIANCE DUE TO POOR WATER QUALITY IS NOT COVERED UNDER WARRANTY. SEE WATER QUALITY STATEMENT (PAGE 4, 5).

Drain Connection

The boiler drain (2" IPS) should be piped to a floor drain near the steamer (NOT directly under the steamer). There should be no solid drain connection; an "open gap" between the boiler and the floor drain is required.

OPERATION

OPERATION OF THE BOILER

Turn on water and steam supply to appliance.

Open cabinet door and turn main power switch ON. Pilot light ignites and water begins to fill boiler - observe water gauge sight glass to verify that proper water level is reached.

Once the proper water level is reached, the steam in valve will open and begin to heat water. In approximately 20 minutes, sufficient amount of pressurized steam will have been generated in the heat exchanger. The boiler pressure gauge in the cabinet should indicate steam pressure in a range of 9 to 11 psig. The appliance is now ready for steam generation.

SHUT DOWN

Turn off power switch, open manual drain valve. If unit is equipped with automatic blowdown valve, it will open and drain exchanger. Steam valve will close cutting off supply to exchanger.

COOKER SECTION

CAUTION

Live steam and accumulated hot water in the compartment may be released when the door is opened.

Start-up procedures for your steamer must be completed once daily prior to operation (see instruction plate or above for boiler start up procedures).

If appliance is equipped with optional - "Load Compensating Timer" a pre-heat thermostat is installed in each compartment. This allows the compartment to pre-heat to 185 °F before the cooking time starts. Set timer for one minute. Ready light will go out and cook light will come on; steam will enter compartment. Once compartment has reached the pre-heat temperature (185 °F) the timer will start. After the time selected has elapsed, buzzer will sound indicating the end of the cooking cycle. Steam generation will cease, Cook light will go out and Ready light will come on. To silence buzzer turn timer to its off position.

With ready pilot light on, preheat steamer compartment for one minute when the steamer is to be first used for the day or whenever the compartment is cold.

1. Close compartment doors and set timer to "1 minute".
2. When buzzer sounds, set timer to the "OFF" position.
3. Steamer is now ready for cooking.
4. With cooking compartment preheated and ready pilot light on, place pans of food to be cooked into compartment and shut door.
5. Set timer to cooking time desired. Cooking cycle may be interrupted at any time by opening door and resumed again by closing door.
6. When buzzer sounds, it indicates the end of the cooking cycle and that no more steam is entering the compartment. Cooking pilot light will go off and ready pilot light will come on. Buzzer must be shut off by turning the timer to its off position.

 **CAUTION**

An obstructed drain can cause personal injury or property damage.

Frequently check that the compartment drain and plumbing is free of all obstructions. Never place food containers, food or food portion bags in the cooking compartment in such a way that the compartment drain becomes obstructed.

 **IMPORTANT**

Each compartment is equipped with a removable drain screen. Frequently check the drain screen for accumulation of food particles. Should food particles accumulate against, or clog the drain screen, remove it, clean it thoroughly and then replace it in its original position.

SHUT DOWN

1. To shut down cooking compartment, set timers to their OFF position and leave doors slightly open.
2. At the end of the day, the steam supply must be shut off. Open the door of cabinet base and turn off power switch. Open manual drain valve. If unit is equipped with automatic blowdown valve, it will open and drain the boiler.

 **CAUTION**

If steam supply does not shut off during blowdown, immediately discontinue use of appliance and call for service.

PERIODIC MAINTENANCE

WARNING

Disconnect the unit from the power supply before cleaning or servicing appliance.

NOTICE

Contact the factory, the factory representative or a local service company to perform maintenance and repairs should the appliance malfunction. Refer to warranty terms.

IMPORTANT INSTRUCTIONS

Be sure to flush your boiler water level control daily. Failure to follow this procedure can cause the control to malfunction resulting in serious boiler damage.

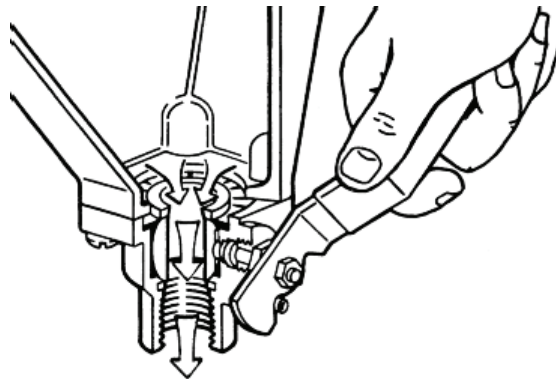

The Boiler Water Level Control installed on your boiler requires periodic maintenance. As boiler water circulates into the float chamber, sand, scale and other sediment may be deposited in the float chamber. While the chamber has been designed with a large accumulation bowl, it is necessary to flush the sediment from the chamber by blowing down the control so that the accumulation of sediment does not interfere with the movement of the float in the control.

Control must be flushed at least once a day.

CAUTION

Protect yourself. When flushing control, hot water and steam will flow out of the drain.

When flushing control, note water level in gauge glass, allow the boiler to fill if necessary, and also to come up to temperature.

Before flushing control, note that water level in gauge glass is within operating range and the boiler pressure is at least 6 psi. While the boiler is being operated, open blowdown valve at bottom of control by rotating the handle counterclockwise about 1/4 turn to fully open the valve.

Opening the blowdown valve also checks the cut-off operation. Float should drop shutting steam off, hot water and steam will flow out the drain flushing away sediment.

 **CAUTION**

If steam supply does not shut off during blowdown, immediately discontinue use of appliance and call for service.

Continue draining water for about fifteen (15) seconds, from control until water is clean. Manually close valve. Recheck gauge glass. If water level has dropped significantly, wait for the boiler to restore water level and pressure and repeat if necessary.

1. Water level control should be opened daily to blowdown sediment and scalant.
2. Observe that the water in gauge glass is clean and clear. Extreme murkiness in water indicates inadequate water quality.
3. Safety valve should be tripped during operation once a week to assure that it functions properly.
4. De-scaling is based on water quality and usage.

 **CAUTION**

Take extra caution when blowing down water level control or tripping safety valve as extreme hot water and live steam are present.

REMOVAL OF SCALE DEPOSITS

This equipment should be installed with the Middleby TruH2O water treatment system which, when properly maintained can provide a scale-free environment for your steamer. However, because water quality can vary it is recommended that the steamer be checked every 90 to 120 days for scale build up. Regular maintenance should be carried out at this time.

DESCALING BOILER

 **CAUTION**

Improper use of this procedure may damage your appliance!

1. With Generator tank empty, close manual blowdown valve.

If appliance is equipped with Automatic Blowdown, turn water supply OFF to appliance. Turn power switch ON, this will energize and close blowdown valve.
2. Remove 3/4" pipe cap from fitting located at top front of generator tank.
3. Insert appropriate hose or tube through opening in generator tank and pour in (1/2) half U.S. gallon of CLR Descaling Solution.
4. Replace 3/4" pipe cap OR union fitting.
5. Open water supply to appliance allowing water to fill Generator tank to required level. On appliances with Manual Blowdown, turn ON power switch, Boiler will fill to the required level.
6. Let appliance cycle. Allow two hours for descaling and cleaning. **DO NOT TURN ON STEAM** to attached appliances or to upper compartment.
7. Open both the blowdown and water level control valves for complete drainage and then close both valves.

On appliances equipped with Automatic Blowdown, turn OFF power switch and open water level control valve, this will allow complete drainage. Once drained, close water level control valve.
8. Turn appliance switch ON. When generator tank is completely filled, turn power switch OFF, this will rinse and drain Generator Tank. Appliances with Manual Blowdown Valve must be opened to drain.
9. Complete Step 8 twice to assure boiler is completely rinsed.
10. Appliance is now ready for use.

CLEANING

 **WARNING**

Never spray water into electric controls.

 **CAUTION**

Do not use cleaning agents that are corrosive.

 **CAUTION**

Live steam and accumulated hot water in the compartment may be released when the door is opened.

 **CAUTION**

Disconnect the power supply during cleaning or servicing.

1. Keep exposed cleanable areas of unit clean at all times.
2. Thoroughly wash oven cavities, door liners, and pan racks at the end of each day, or as required, with a mild detergent and water to prevent bacterial growth and odors.
3. Remove drain screens from inside compartment drains. Using a plastic bottle brush and mild detergent, clean inside the drain opening ensuring there is no food residue or blockage. Clean the drain screen and replace in its original position.
4. Wash gasket sealing surface daily with mild detergent to remove harmful food acids.
5. Rinse entire unit and dry. **DO NOT GET WATER** in electrical box or any electrical component.

ADJUSTMENTS

CALIBRATE PRESSURE SWITCHES

NOTICE

Pressure switches are factory set.
Calibration is only required if pressure switches are replaced or if adjustment is required.

⚠ CAUTION

Adjusting knob and nut will turn easily until they hit a stop. Do not over torque. Over torquing may cause damage.

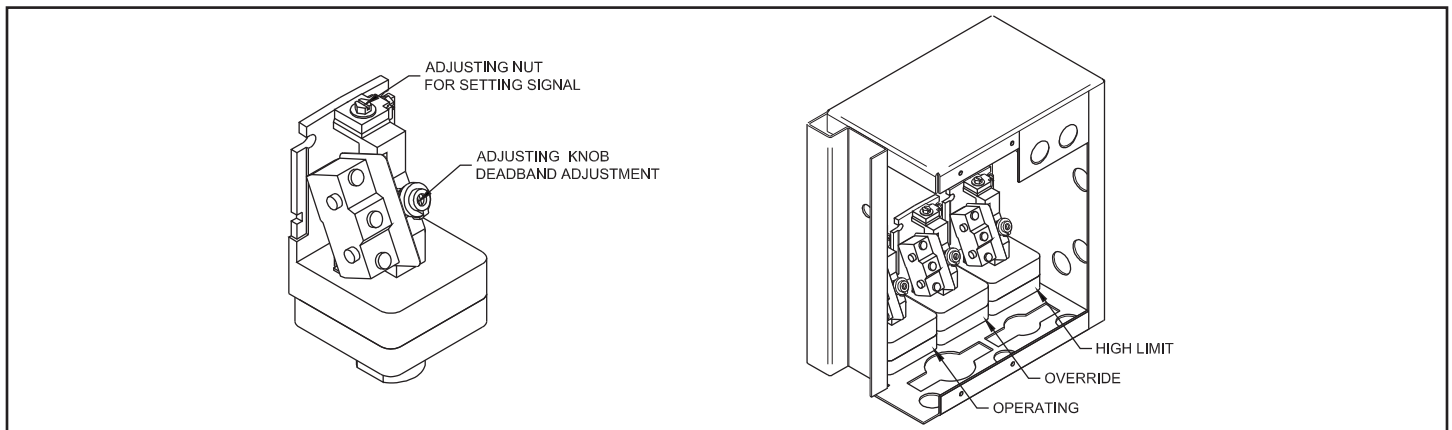

1. Turn the adjusting knob clockwise to the deadband to maximum.
2. Turn the adjusting nut clockwise to maximum.
3. Adjust in the following sequence:
 - High limit pressure switch.
 - Override pressure switch (if equipped).
 - Operating pressure switch.
 - Use relief valve to release pressure from boiler for setting adjustments.

High Limit Pressure Switches

Allow pressure to build until unit shuts off. This should occur at 15 PSI. Set the adjusting nut to switch off at 14.5 PSI on the gauge.

Override Pressure Switches

Set the adjusting nut to switch off at 13 PSI on the gauge.

Operating Pressure Switches

Set the high signal to switch off at 11 PSI on the gauge.

4. Release pressure in boiler below 9 PSI. The boiler should fire and once the pressure has reached 11 PSI, the boiler should shut off. Repeat this process several times to make sure boiler operates between 9 and 11 PSI.

Once completed, pressure switches have been calibrated.

TROUBLESHOOTING

NOTICE

Contact the factory, the factory representative or local service company to perform maintenance and repairs. Refer to warranty terms.

NOTICE

At least twice a year have an authorized service person clean and adjust the unit for maximum performance.

DOOR LEAKS

1. Check for damage to door gasket.
2. Compartment drain opening or associated piping may be blocked.

WATER ACCUMULATES IN THE COMPARTMENT

1. Compartment drain screen clogged. Remove and clean thoroughly and replace.

WATER NOT BEING SUPPLIED TO HEAT EXCHANGER

1. Water supply is "OFF".
2. Defective water fill solenoid.
3. Water level control clogged or defective, unable to operate fill valve.
4. Check drain valve is closed. Also check that water level control valve is closed.
5. Supply water pressure too low.

AUTOMATIC BLOWDOWN VALVE DOES NOT DRAIN

1. Defective Blowdown valve.
2. Heat exchanger build up of scalant clogging drain lines and valve.

Heat Exchanger Achieves Pressure Slower Than Normal

1. Heavy build up of lime on heat exchanger tubes.
2. Steam supply pressure too low.

SAFETY VALVE BLOWS

1. Defective safety valve.
2. Pressure too high. Pressure switch requires adjustment (lower) or may be defective.

NOTES

NOTES

SCX-16 & SCX-24

Steam Coil Cabinet Base Convection Steamers



A product with the Crown name incorporates the best in durability and low maintenance. We all recognize, however, that replacement parts and occasional professional service may be necessary to extend the useful life of this appliance. When service is needed, contact a Crown Authorized Service Agency, or your dealer. To avoid confusion, always refer to the model number, serial number, and type of your appliance.



CROWN FOOD SERVICE EQUIPMENT

 A Middleby Company

70 Oakdale Road, Downsview (Toronto) Ontario, Canada, M3N 1V9
Telephone: 919-762-1000 www.crownsteamgroup.com