



IMPORTANT FOR FUTURE REFERENCE

Please complete this information and retain this manual for the life of the equipment:

Model #: _____

Serial #: _____

Date Purchased: _____

INSTALLATION & OPERATION MANUAL

Gas Cabinet Base Compartment Cookers GC-2 GC-3 GDA-2 GDA-3

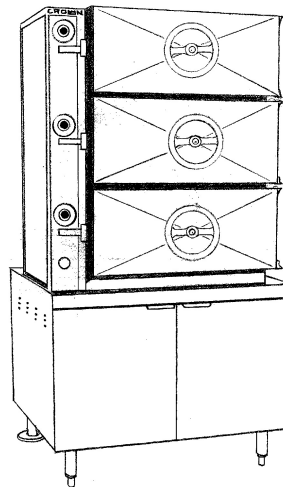

⚠ WARNING

Improper installation, adjustment, alteration, service or maintenance can cause property damage, injury or death. Read the installation, operating and maintenance instructions thoroughly before installing or servicing this equipment.

CROWN FOOD SERVICE EQUIPMENT

Division of Middleby Canada Company Inc.

70 Oakdale Road, Downsview (Toronto) Ontario, Canada, M3N 1V9

Telephone: 919-762-1000

www.crownsteamgroup.com

Printed in Canada



IMPORTANT NOTES FOR INSTALLATION AND OPERATION

It is recommended that this manual be read thoroughly and that all instructions be followed carefully.

	This is the safety alert symbol. It is used to alert you to potential personal injury hazards. Obey all safety messages that follow this symbol to avoid possible injury or death.
---	---

	WARNING: Improper installation, operation, adjustment, alteration, service or maintenance can cause property damage, injury or death. Read the installation, operating and maintenance instructions thoroughly before installing, operating or servicing this equipment.
---	---

This manual should be retained for future reference.

	FOR YOUR SAFETY: Do not store or use gasoline or other flammable vapors or liquids in the vicinity of this or any other appliance.
--	---

Intended for commercial use only. Not for household use.

PURCHASER: Instructions to be followed in the event that the operator of this appliance smells gas must be posted in a prominent location. This information shall be obtained by consulting the local gas supplier.

Keep the appliance area free and clear from combustibles.

Do not obstruct the flow of combustion and ventilation air.

Adequate clearances must be maintained for servicing and proper operation.

Do not attempt to operate this unit in the event of a power failure.

NOTICE: Contact the factory, the factory representative or local service company to perform maintenance and repairs.

TABLE OF CONTENTS

DESCRIPTION	PAGE
1.0 Service Connections	4
2.0 Installation Instructions	6
3.0 Operation Instructions	11
4.0 Operation Instructions for Boilers with CSD-1 Controls	17
5.0 Cooking Guidelines	20
6.0 Cleaning	22
7.0 Maintenance	23
8.0 Troubleshooting	29

INSTALLATION AND OPERATION MANUAL, PRESSURE COOKERS, GC-2, GC-3, GDA-2, GDA-3

1.0 SERVICE CONNECTIONS

- ⚡ – ELECTRICAL CONNECTION: 1/2" conduit connection to controls. 2 AMPS per compartment, 120-60-1 or 220-50-1.
- 💧 – DRAIN: 2"IPS piped to open floor drain. No Solid Connection.
- 🔥 – GAS CONNECTION: 3/4"IPS supply line required.
- ❄️ – COLD WATER: 3/8" O.D. tubing at 25-50 PSI(170-345 kPa).
- 🌀 – STEAM TAKE-OFF CONNECTION: 3/4"IPS optional to operate adjacent equipment.

WATER QUALITY STATEMENT

Water quality is the major factor affecting the performance of your appliance. If you are unsure of water quality, consult a local water treatment specialist and have the water analyzed. Your water supply must be within these general guidelines:

Total dissolved solids	Less than 60 PPM
Total alkalinity	Less than 20 PPM
Silica	Less than 13 PPM
Chlorine	Less than 1.5 PPM
pH Factor	7.0-8.5

Water which fails to meet these standards should be treated by installation of water conditioner.

FAILURE OR MALFUNCTION OF THIS APPLIANCE DUE TO POOR WATER QUALITY IS NOT COVERED UNDER WARRANTY.

MODEL	GAS SUPPLY		
	WATER COLUMN PRESSURES	BTU/HR.	kW/HR.
GC-2 or GC-3	Natural	200,000	58.6
	Propane min. 7" (178mm) min. 11" (279 mm)	250,000	73.3

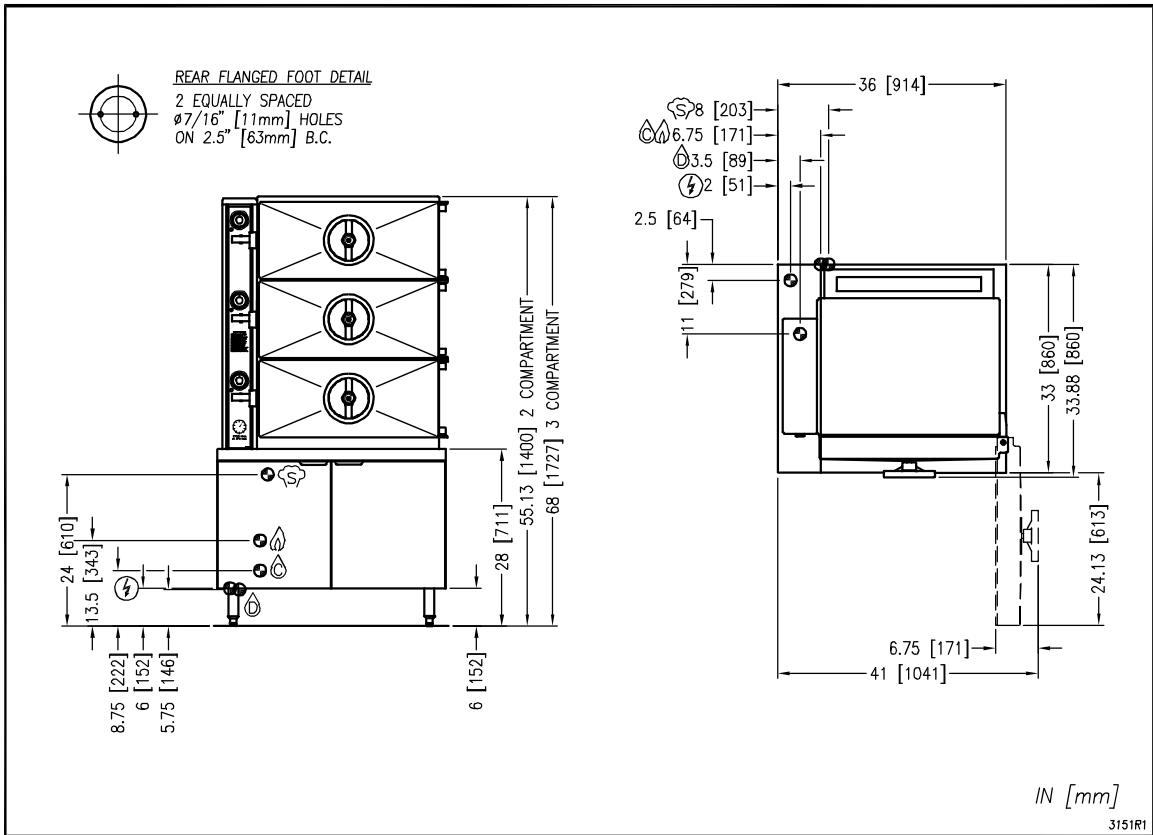

As continued product improvement is a policy of Crown, specifications are subject to change without notice.

INSTALLATION AND OPERATION MANUAL, PRESSURE COOKERS, GC-2, GC-3, GDA-2, GDA-3

1.0 SERVICE CONNECTIONS (Continued)

- ⚡ – ELECTRICAL CONNECTION: 1/2" conduit connection to controls.
2 AMPS per compartment, 120-60-1 or 220-50-1
- Ⓜ – DRAIN: 2"IPS piped to open floor drain. No Solid Connection.
- ⚡ – GAS CONNECTION: 3/4"IPS supply line required.
- Ⓜ – COLD WATER: 3/8" O.D. tubing at 25-50 PSI(170-345 kPa).
- Ⓜ – STEAM TAKE-OFF CONNECTION: 3/4"IPS optional to operate adjacent equipment.

WATER QUALITY STATEMENT

Water quality is the major factor affecting the performance of your appliance. If you are unsure of water quality, consult a local water treatment specialist and have the water analyzed. Your water supply must be within these general guidelines:

Total dissolved solids	Less than 60 PPM
Total alkalinity	Less than 20 PPM
Silica	Less than 13 PPM
Chlorine	Less than 1.5 PPM
pH Factor	7.0-8.5

Water which fails to meet these standards should be treated by installation of water conditioner.

FAILURE OR MALFUNCTION OF THIS APPLIANCE DUE TO POOR WATER QUALITY IS NOT COVERED UNDER WARRANTY.

MODEL	GAS SUPPLY			
GDA-2 or GDA-3	WATER COLUMN PRESSURES		BTU/HR.	kW/HR.
	Natural min. 7" (178mm)	Propane min. 11" (279 mm)	250,000 300,000	73.3 87.9

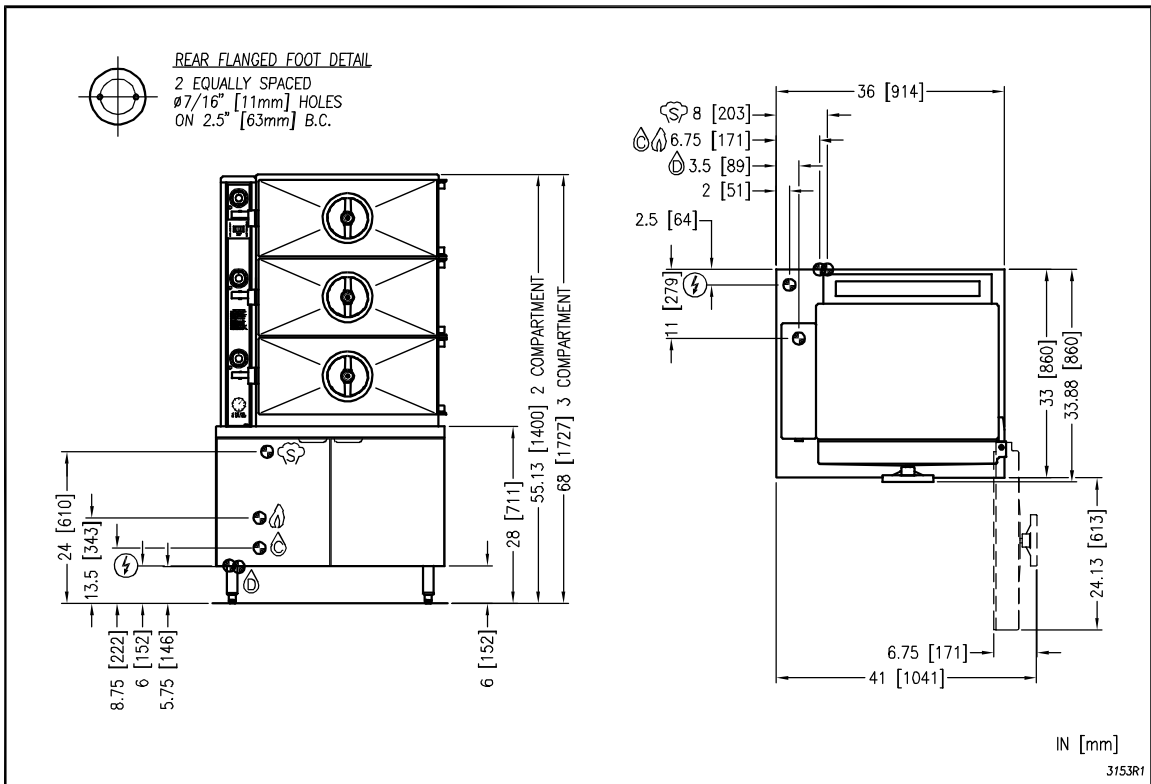

As continued product improvement is a policy of Crown, specifications are subject to change without notice.

2.0 INSTALLATION INSTRUCTIONS

GENERAL

Models GC-2 and GC-3 Cookers have two and three pressurized steaming compartments for cooking vegetables, fish, eggs, and other foods.

Models GDA-2 and GDA-3 Cookers have two or three compartments; the upper compartment can be switched to provide either pressurized or pressureless steaming while the lower compartment(s) provide pressurized cooking only.

The gas boiler in the cabinet base is rated, 250,000 BTU/hr and available in 300,000 BTU/hour, in natural or propane gas.

Accessory 12 x 20" stainless steel pans are available, solid or perforated, in 2.5, 4 and 6" depth.

ACCOMMODATION

MODEL	COMPARTMENTS	TOTAL NUMBER OF PANS			NUMBER OF PANS PER COMPARTMENT		
		2.5" DEPTH	4" DEPTH	6" DEPTH	2.5" DEPTH	4" DEPTH	6" DEPTH
GC-2, GDA-2	2	16	8	4	8	4	2
GC-3, GDA-3	3	24	12	6			

Each compartment has a 0 - 60 minute timer and a buzzer that requires manual shut-off. Doors cannot be opened during cooking; each door is equipped with an interlock feature that stops delivery of steam to the compartment before the door can be opened.

An optional Steam Take-Off Connection (3/4" NPT) can provide steam for adjacent equipment.

2.0 INSTALLATION INSTRUCTIONS (Continued)

INSTALLATION

UNPACKING

Immediately after unpacking, check for possible shipping damage. If the appliance is found to be damaged, save the packaging material and contact the carrier within 15 days of delivery. Before installing, verify the electrical and gas rating agrees with the specification on the rating plate.

LOCATION

Position the boiler in its installation location. Check that there are sufficient clearances to service the controls, door swing, etc. Also adequate clearance must be left for making the required supply and drain connections.

Allow enough space between any other piece of equipment or wall for service access. Service to the controls may be required on the left and/or right side panels of the cabinet.

INSTALLATION CODES AND STANDARDS

Gas installation to conform to local codes, or in absence of local codes, with the National Fuel Gas Code - ANSI Z223.1/NFPA 54, or the Natural Gas and Propane Installation Code, CSA B149.1, as applicable, including:

1. The appliance and its individual shut off valve must be disconnected from the gas supply piping system during any pressure testing of that system at pressures in excess of ½ psi (3.5 kPa).
2. The appliance must be isolated from the gas supply piping system by closing its individual manual shut off valve during any pressure testing of the gas supply piping system at test pressures equal to or less than ½ psi (3.5 kPa).

Electrical grounding must be provided in accordance with local codes, or in the absence of local codes, with the National Electrical Code ANSI/NFPA 70. In Canada, installation must be in accordance with the Canadian Electrical Code CSA C22.2.

2.0 INSTALLATION INSTRUCTIONS (Continued)

LEVELLING AND ANCHORING THE CABINET

1. Place appliance in the installation position.
2. Using a spirit level or pan of water, level the appliance. Then elevate the right side about 1/8" to assure proper compartment drainage.
3. Mark hole locations on the floor through the anchoring holes provided in the rear flanged adjustable feet.
4. Remove appliance from installation position and drill holes in locations marked on the floor. (See installation diagram on page 4.) Insert proper anchoring devices (not supplied).
5. Place appliance back in the installation position.
6. Recheck level.
7. Bolt and anchor appliance securely to the floor.
8. Seal bolts and flanged feet with silastic or equivalent compound.

ELECTRICAL CONNECTIONS

	WARNING: Electrical and grounding connections must comply with the applicable portions of the National Electrical Code and/or other local electrical codes.
---	--

	WARNING: Disconnect electrical power supply and place a tag at the disconnect switch to indicate you are working on the circuit.
---	---

ELECTRICAL CONNECTIONS

When making electrical connections, use copper wire suitable for at least 200°F (90°C). The steamer must be grounded in accordance with the National Electrical Code or applicable local codes. The wiring diagram is located on the inside of the right panel.

EXHAUST HOOD

An exhaust system should be located directly above the steamer to exhaust steam and heat generated by the steamer.

2.0 INSTALLATIONS INSTRUCTIONS (Continued)

SERVICE CONNECTIONS

	NOTICE: If this equipment is being installed at over 2,000 feet altitude and was not so specified on order, contact service department. Failure to install with proper orifice sizing may void the warranty.
---	---

PLUMBING CONNECTIONS

	WARNING: Plumbing connections must comply with applicable sanitary, safety, and plumbing codes.
---	--

WATER SUPPLY CONNECTION

The incoming cold water supply connection, at the rear of the cooker cabinet, requires 3/8" tubing and water pressure of 25 - 50 psi. A manual shut-off valve must be provided convenient to the appliance; this valve should be open when the boiler is in operation.

FAILURE OR MALFUNCTION OF THIS APPLIANCE DUE TO POOR WATER QUALITY IS NOT COVERED UNDER WARRANTY. SEE WATER QUALITY STATEMENT (PAGE 4 AND 5.)

DRAIN CONNECTION

The cooker drain (2" IPS) should be piped to a floor drain near the cooker. There should be no solid drain connection; an "open gap" between the steamer and the floor drain is required.

GAS CONNECTION

1. The data plate on the cabinet door of the boiler indicates the type of gas your unit is equipped to burn. DO NOT connect to any other gas type.

Keep the appliance area free and clear from combustible substances. Do not obstruct the flow of combustion and ventilation air.

2. A 3/4" NPT line is provided at the rear for the connection. Each boiler is equipped with an internal pressure regulator which is set at 3.5" W.C. manifold pressure for natural gas or 10.5" W.C. for L.P. gas. Use the 1/8" pipe tap on the burner manifold for checking pressure.

2.0 INSTALLATION INSTRUCTIONS (Continued)

GAS CONNECTION (Continued)

An adequate gas supply is necessary. Undersized or low pressure lines will restrict the volume of gas required for satisfactory performance. A steady supply pressure, between 7" W.C. and 14" W.C. for natural gas and 11" W.C. and 14" W.C. for propane gas is recommended. With all units operating simultaneously, the manifold pressure on all units should not show any appreciable drop. Fluctuations of more than 25% on natural gas, and 10% on propane gas, will create pilot problems and affect burner operating characteristics. Contact your gas company for correct supply line sizes.

Purge the supply line to clean out any dust, dirt, or foreign matter before connecting the line to the unit.



CAUTION: The pipe thread compound used when installing pipes must be a type that is resistant to the action of liquified petroleum or propane gases.

Codes require that a gas shut-off valve be installed in the gas line prior to the steamer. Make sure the pipes are clean and free of obstructions, dirt, and piping compound.

NOTICE: If applicable, the vent line from the gas appliance pressure regulator shall be installed to the outdoors in accordance with local codes or, in the absence of local codes, with the *National Fuel Gas Code, ANSI Z223.1/NFPA 54*, or the *Natural Gas and Propane Installation Code CSA B149.1*, as applicable.



WARNING: Prior to start-up, check all joints in the gas supply line for leaks. Use soap and water solution. Do not use an open flame.

3.0 OPERATION INSTRUCTIONS

	CAUTION: Operating, testing, and servicing should only be performed by qualified personnel.
---	--

	CAUTION: The appliance and its parts are hot. Use care when operating, cleaning and servicing the appliance.
---	---

INITIAL OPERATIONS CHECK

The pressure gauge on the face of the Cooker Control Panel should indicate pressure of 5 to 6 psi. Open cooker compartment door and set timer dial to 5 minutes and pull out operating handle and observe that steam is entering the compartment.

	CAUTION: Stand clear of compartment opening as live steam is being released.
---	---

Set timer dial back to "O" and the buzzer will sound and may only be silenced by pushing in on the operating handle. Check each compartment in this manner.

Close compartment door and turn handwheel clockwise so the door gasket seals.

Set timer at 5 minutes. Pull out operating handle and set in position. Steam should be heard entering the compartment; also you should hear a hissing sound as compartment air exits the vent at the rear side, until replaced by steam.

Observe that door gasket seals properly and that no leaks are evident.

After five minutes: Timer should read "0", steam will stop entering compartment, the exhaust valve will open allowing steam and condensate water to exit, and the buzzer will sound.

To silence the buzzer, push in the operating handle.

Observe flow at the open drain. Steam from the compartment is cooled by a flow of cold water from the thermostatically controlled valve. Pause one minute to allow steam and condensate to exit. Turn handwheel counterclockwise to avoid pressure on the door gasket when not in use.

3.0 OPERATION INSTRUCTIONS (Continued)

Move the door latch to the left to release and open the door. Check each compartment in this manner.

The gas boiler cycles on and off maintaining steam pressure in the boiler from 9 to 11 psi.

Turn main power switch OFF. Open the manual Blowdown valve. This will release hot water and steam from the boiler tank which mixes with cold water released by the thermostatically controlled solenoid valve and travels to the drain.

If equipped with automatic blowdown valve, hot water and steam will be released once the main power switch has been turned off.

	WARNING: The steamer and its parts are hot. Use care when operating, cleaning, or servicing the steamer.
---	---

	CAUTION: Live steam and accumulated hot water in the compartment may be released when the door is opened.
---	--

COMPARTMENT CONTROLS (Figure 1)

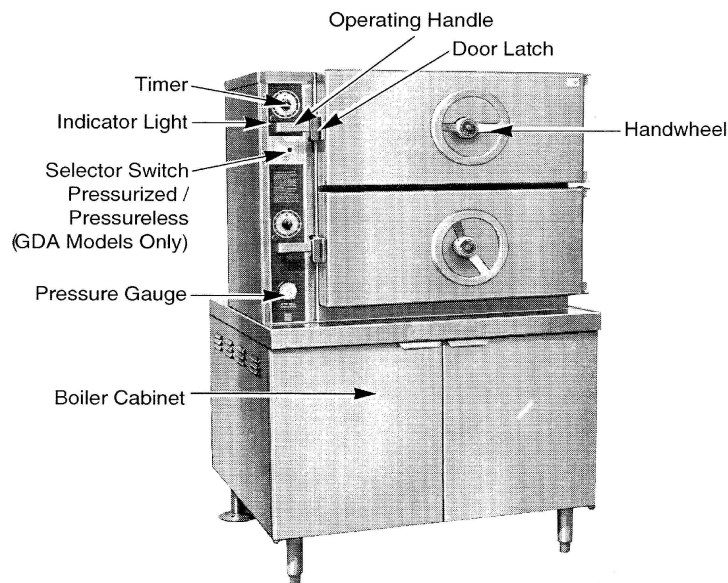

3.0 OPERATION INSTRUCTIONS (Continued)

COMPARTMENT CONTROLS (Figure 1)

Timer (0 to 60 minutes) -	Sets the steam time for the compartment.
Indicator Light -	Timed cycle is in progress when lit.
Selector Switch - (GDA Models Only)	PRESSURIZED means top compartment operates at 6 psi. PRESSURELESS means top compartment steams without pressure, the exhaust valve is open to the drain.
Operating Handle -	PULL OUT to send steam to compartment, lock door, and enable operation. PUSH IN to silence buzzer at end of cycle.
Door Latch -	Holds door closed and prevents door from fully opening until operating handle is pushed in; move the door latch to the left to fully open door after steam and condensate drain (1 minute) and handwheel is turned fully counterclockwise.
Handwheel -	Turn clockwise to seal door at start of cycle. After pressure release at end of cycle, turn counterclockwise to open.
Buzzer (not shown) -	Sounds an audible signal when timer cycle is complete. To silence buzzer, push in operating handle.
Pressure Gauge -	Indicates steam pressure: 6 psi with compartments inactive, 4.5 - 6 psi during a cooking cycle.

3.0 OPERATION INSTRUCTIONS (Continued)

STEAMING

Each cooker compartment is controlled by its own controls. When a compartment is not operating, the drain is open and the steam inlet valve from the boiler is closed. Food, properly portioned and in appropriate solid or perforated pans, is placed on rack supports (or wire shelves) in the steaming compartment. After closing and sealing the door, setting the timer, and pulling out the operating handle, the steam inlet valve from the boiler opens, allowing steam at a pressure of 6 psi to enter the compartment. Air from the sealed compartment exits through the vent until the temperature reaches 180°F; then the vent closes and the compartment can become pressurized. [On GDA models only, if the top compartment has been switched to pressureless steaming, steam enters the compartment and is exhausted to the drain without pressurizing the compartment.] Steaming continues until the timer reaches "0" and the buzzer sounds. To silence the buzzer, push in the operating handle. Wait one minute for steam or hot water to drain away. Open the door and remove the cooked food.

The cabinet (lower portion of steamer) contains the gas steam generator or boiler.

PREHEAT COMPARTMENTS

If the steamer has been standing idle and the compartments are cold, preheat before loading.

3.0 OPERATION INSTRUCTIONS

	WARNING: Do not force the gas control knob. Use only your hand to turn the gas control knob. Never use any tool. If the gas control knob will not operate by hand the gas control should be replaced by a qualified service technician.
---	--

	WARNING: Do not disassemble the gas control; it contains no replaceable components. Attempted disassembly or repair may damage the gas control.
---	--

	WARNING: In the event of main burner ignition failure, a 5 minute purge period must be observed prior to re-establishing ignition source.
---	--

For CSD-1 equipped boilers, see section 4.0 for Operation Instructions for CSD-1 Equipped Boiler.

BOILER CONTROLS (Inside Cabinet)

- | | |
|-------------------------|--|
| Main Power Switch | <ul style="list-style-type: none">- ON fills the boiler tank and turns the boiler controls on. You should allow 20 minutes to fill the tank and generate steam.- OFF shuts off the boiler controls and opens the automatic blowdown valve, emptying the boiler tank and releasing water and steam to the drain. This should be done at least once daily to remove sediment, lime, or scale. |
| Pilot Light | <ul style="list-style-type: none">- Indicates main power is ON. |
| Boiler Pressure Gauge | <ul style="list-style-type: none">- Should read 9 to 11 psi during operation; 0 psi during shutdown. |
| Water Level Sight Glass | <ul style="list-style-type: none">- Observe level of water in the boiler and water quality. Murkiness in the water indicates inadequate water quality; the owner must supply proper water to the boiler (see page 4, Water Quality Statement). |
| Water Level Control | <ul style="list-style-type: none">- While ON, briefly open the water level control daily to remove any sediment that might accumulate. (See page 23 for detailed instructions). |

BOILER CONTROLS (Inside Cabinet) Continued

- Safety Valve - This valve will release (pop off) if the boiler has too much pressure. Once a week, this valve should be tripped during operation to make sure it functions properly.
- Pressure Regulator - Reduces the steam pressure from the boiler to the steamer compartments to 6 psi. Twice a year, unscrew the large hex head plug located at the bottom of the regulator and remove and clean the strainer. Carefully reassemble.

	CAUTION: If you smell gas during the lighting procedure, immediately shut off the gas supply until the leak has been corrected.
---	--

1. START-UP - BOILER OPERATION WITH STANDING PILOT IGNITION

Open manual gas shut off supply valve and if the appliance has a manual blowdown valve, close it. Open cabinet door and turn ON power switch located on left side. Green pilot light will come on, water will begin to enter boiler and required water level will be reached in about three minutes. Observe water gauge glass to verify.

The dial on the combination gas control valve has three positions (ON-PILOT-OFF) for manual gas control of main burners and pilot. Turn DIAL to PILOT. Depress dial and light burner located on centre main burner of boiler. Maintain dial in depressed position for about 30 seconds and release. Observe that the pilot burner flame stays on. If at any time the flame should become extinguished, a 5 minute period of complete shut off of gas supply is required before relighting.

Turn dial to ON and burners should ignite. Steam generation will now commence and be completed in approximately 15 minutes. Steam generation should reach approximately 11 psi as indicated on the pressure gauge on the boiler.

2. START UP - BOILER OPERATION WITH ELECTRONIC IGNITION

Open manual gas supply valve.

Open cabinet door and turn main power switch ON. Green pilot light will come on, water will begin to enter boiler and required water level will be reached in about three minutes. Observe water gauge sight glass to verify.

4.0 OPERATION INSTRUCTIONS FOR BOILERS WITH CSD-1 CONTROLS



WARNING: In the event of main burner ignition failure, a 5 minute purge period must be observed prior to re-establishing ignition source.

INITIAL START-UP PROCEDURE

1. Open the manual gas shut-off supply valve.
2. Close the manual blowdown valve, if so equipped.
3. Light the pilot burner.

The dial on the gas combination valve has three positions (ON - OFF - PILOT) for manual gas control of main burners and pilot burner. Turn the dial on the gas combination valve to "PILOT", depress the dial and light the pilot burner on the centre burner. Maintain the dial in depressed position for about 30 seconds and release. Observe the pilot flame stays ON. Turn dial to "ON".

If at any time the flame should become extinguished, a five (5) minute purging is required before relighting is attempted.

4. Open cabinet door and turn "ON" the power switch.

The green pilot light will come "ON". Water should begin to enter the boiler. When enough water has entered the boiler the (amber) "STANDBY" pilot light will come on.

5. Press the "RESET" switch to begin boiler operation.

The "STANDBY" pilot light will go off and the boiler will begin operation.

4.0 OPERATION INSTRUCTION FOR BOILERS WITH CSD-1 CONTROLS (Continued)

Daily Startup Procedure

1. Close the manual blowdown valve, if so equipped.
2. Examine that the pilot burner flame is burning. If the pilot burner is out, a five (5) minute period of complete gas supply shut off is required before relighting.
3. Open cabinet door and turn "ON" the power switch.

The green pilot light will come "ON". Water will begin to enter the boiler. When enough water has entered the boiler the (amber) "STANDBY" pilot light will come on.

4. Press the "RESET" switch to begin the boiler operation. The "STANDBY" pilot light will go off and the boiler will begin operation.

Daily Shutdown Procedure

1. Turn "OFF" the power switch. Observe that the burners go off.
2. Open the manual blowdown valve, if so equipped. If the appliance is equipped with an automatic blowdown solenoid valve, the boiler's contents, water and steam will be blown out and exhausted through the appliance drain. The cold water solenoid valve will be activated.

Complete Shutdown Procedure

If the appliance is not intended to be operational for a lengthy period, then shut it down completely.

1. Open the manual blowdown valve, if so equipped.
2. Shut off all supplies of power, gas and water to the appliance.

Normal Boiler Operating Cycle

Water Fill Cycle

On the initial filling of the boiler, the reset switch must be activated to initialize the safety lockout circuit. Once the water in the boiler has reached the proper level, the level control will open the circuit to the fill solenoid valve, stopping the flow of water to the boiler. As the water is consumed in the production of steam, the level control will close the circuit to the fill solenoid and water will be supplied to the boiler.

4.0 OPERATION INSTRUCTION FOR BOILERS WITH CSD-1 CONTROLS (Continued)

Firing Cycle

The gas valve is operated by pressure sensing devices. On the initial operation of the boiler, steam generation should reach 11 psi in approximately 15 minutes. At this point the "Operating Pressure" switch will open, closing the gas valve. When pressure drops to 9 psi, the pressure switch closes, the gas valve will open and ignition should occur.

Should the pressure rise more than 14.5 psi the "Override Pressure Switch" will close the circuit to the override solenoid valve, releasing excess steam.

Condensing Drain

A thermostat is located in the drain assembly and is activated by the temperature of steam. The thermostat opens the cooling solenoid valve, in turn supplying water to the drain to condense steam.

Automatic Blowdown Valve

If the unit has an automatic blowdown valve, it is activated by the main power switch. The boiler will be drained should the main power switch be turned "OFF".

SAFETY LOCKOUT CONDITIONS

High Temperature Condition

A high temperature safety device is installed on the boiler. Should the temperature exceed the limit of this device, the boiler will be shut down and put in a state of lockout. The "Temperature" pilot light (red), and the "Standby" pilot (amber), will come on.

High Pressure Condition

A high pressure safety switch is installed on the boiler. Should the pressure exceed the limit of this device, the boiler will be shut down and put into a state of lockout. The "Pressure" pilot light (red), and the standby pilot light (amber), will come on. Should this device fail to operate, the safety relief valve will open.

Low Water Condition

A second low water safety cut off is supplied with the boiler. Should the water level fall below normal operating levels, this device will shut down and put the boiler in a state of lockout. The "Low Water" pilot light (red), and the "Standby" pilot light (amber) will come on.

5.0 COOKING GUIDELINES

The cooking guidelines in this manual are suggestions only. You should experiment with your food products to determine cooking times that will give you the best results. Variables which affect cooking time include size, weight, thickness of foods, temperature, density, previous condition of the foods (fresh, pre-blanching or frozen) and degree of doneness desired.

To allow steam to circulate around the pans, food must be spread evenly and not piled too high. Best results are obtained after the compartments are allowed to preheat. When all compartments are to be loaded at the same time, it is best to allow the first compartment to reach 4 - 4.5 psig before starting the next compartment. When processing frozen vegetables, use half the suggested pan weights and allow sufficient time for cooking doneness.

COOKING GUIDELINES

PRODUCT	PAN DEPTH	PERFORATED OR SOLID	WEIGHT/QUANTITY PER PAN	STEAM TIME MINUTES	PANS PER COMPARTMENT
VEGETABLES (Fresh)					
Beans, lima	2.5"	Perf.	5 lbs.	10 - 12 13 - 15	1 - 3 4 - 6
Beans, string or wax	2.5"	Perf.	6 lbs.	15 - 20 20 - 25	1 - 3 4 - 6
Broccoli, florets	2.5"	Perf.	6 lbs.	8 - 10 10 - 12	1 - 3 4 - 6
Broccoli, stalks	2.5"	Perf.	6 lbs.	10 - 15 15 - 20	1 - 3 4 - 6
Carrots, sliced	2.5"	Perf.	9 lbs.	18 - 21 21 - 25	1 - 3 4 - 6
Corn	2.5"	Perf.	5 lbs.	9 - 10 11 - 13	1 - 3 4 - 6
Peas	2.5"	Perf.	5 lbs.	6 - 7 8 - 9	1 - 3 4 - 6
Potatoes, chunked	2.5"	Perf.	10 lbs.	20 - 25 25 - 30	1 - 3 4 - 6
Rice, add 1 gallon water	4"	Solid	4 lbs.	22 - 24 25 - 27	1 - 2 3 - 4
Spinach, cut, cleaned	4"	Perf.	3 lbs.	3 - 5 4 - 6	1 - 2 3 - 4
Vegetables, canned	2.5"	Solid	7 lbs.	4 - 5 5 - 8	1 - 3 4 - 6
OTHER FOODS					

INSTALLATION AND OPERATION MANUAL, PRESSURE COOKERS, GC-2, GC-3, GDA-2, GDA-3

PRODUCT	PAN DEPTH	PERFORATED OR SOLID	WEIGHT/QUANTITY PER PAN	STEAM TIME MINUTES	PANS PER COMPARTMENT
Chicken	2.5"	Perf.	8 lbs.	18 - 25 25 - 30	1 - 3 4 - 6
Eggs, out-of-shell	2.5"	Solid	4 doz.	6 - 7 7 - 8	1 - 3 4 - 6
Eggs, in-shell	2.5"	Perf.	3 doz.	2 - 3 4 - 6	1 - 3 4 - 7
Fish, fillets	2.5"	Perf.	3 lbs.	8 - 12 10 - 15	1 - 3 4 - 6
Meatloaf	2.5"	Solid (for broth)	15 lbs.	35 - 40 40 - 45	1 - 3 4 - 6
Spaghetti, add 7 quarts of water	4"	Solid	3 lbs.	20 - 22 23 - 26	1 - 2 3 - 3
Turkey	2.5"	Perf.	10 - 12 lbs.	50 - 60 60 - 75	1 - 3 4 - 6

6.0 CLEANING



WARNING: Disconnect the power supply to the appliance before cleaning or servicing.



CAUTION: Do not use cleaning agents that are corrosive.

Keep exposed cleanable areas of unit clean at all times. Use a mild soap and warm clean water. Rinse thoroughly with clean water and wipe dry with a clean soft cloth.

Remove pans, shelves, slide racks and compartment strainers and clean using mild warm clean soapy water.

Remove food sediment from compartment and thoroughly wash oven cavities, door liners and door gaskets at the end of each day or as required.

Never use steel wool on stainless steel.

Do not apply food oils or petroleum lubricants to the door gaskets.

Replace racks, shelves and compartment strainers.

Turn handwheel fully counterclockwise to retract the gasket plate and avoid pressure on the door gasket when the cooker is not in use.

7.0 MAINTENANCE

1. Water level control should be opened daily to blow down sediment and scalant.
2. Observe that water in gauge glass is clean and clear. Extreme murkiness in water indicates inadequate water quality.
3. Safety valve should be tripped during operation once a week to assure that it functions.
4. Keep all exposed cleanable areas of unit clean at all times.
5. De-Scaling is based on water quality and useage.



CAUTION: An obstructed drain can cause personal injury or property damage.

Do not allow any sediment to be exhausted through exhaust valves (compartment drains). Remove all sediment and clean. Greasy foods may leave deposits that will accumulate in the exhaust drain and drain lines. To remove close doors and seal, set timers and at frequent intervals release operating arm and blowdown unit, releasing steam through valves and drain lines to dissolve grease.

The thrust screw in each compartment door should be lubricated each month to prevent handwheel from becoming difficult to turn. To lubricate, turn handwheel clockwise until gasket plate is fully extended. Grasp finger hooks on door plate and lift up and out. Apply grease NLG12 consistency of 285W60 viscosity liberally on thrust screw, rotate handwheel to ensure complete coverage. Replace gasket plate.

Be sure to flush your boiler water level control daily. Failure to follow this procedure can cause the control to malfunction resulting in serious boiler damage.

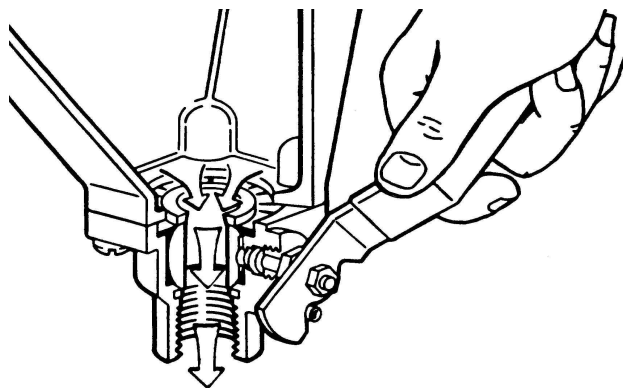

7.0 MAINTENANCE (Continued)

The Boiler Water Level Control installed on your boiler requires periodic maintenance. As boiler water circulates into the float chamber, sand, scale and other sediment may be deposited in the float chamber. While the chamber has been designed with a large accumulation bowl, it is necessary to flush the sediment from the chamber by blowing down the control so that the accumulation of sediment does not interfere with the movement of the float in the control. Control must be flushed at least once a day.



CAUTION: Protect yourself. When flushing control, hot water and steam will flow out of the drain.

When flushing control, note water level in gauge glass, allow the boiler to fill if necessary, and also to come up to temperature.

Before flushing control, note that water level in gauge glass is within operating range and the boiler pressure is at least 6 psi. While the boiler is being fired, open blowdown valve at bottom of control by rotating the handle counterclockwise about 1/4 turn to fully open the valve. Opening the blowdown valve also checks the cut-off operation. Float should drop shutting elements off, hot water and steam will flow out the drain flushing away sediment.

7.0 **MAINTENANCE** (Continued)



CAUTION: Protect yourself. When flushing control, hot water and steam will flow out of the drain.

When flushing control, note water level in gauge glass, allow the boiler to fill if necessary, and also to come up to temperature.

Before flushing control, note that water level in gauge glass is within operating range and the boiler pressure is at least 6 psi. While the boiler is being fired, open blowdown valve at bottom of control by rotating the handle counterclockwise about 1/4 turn to fully open the valve. Opening the blowdown valve also checks the cut-off operation. Float should drop shutting burners off, hot water and steam will flow out the drain flushing away sediment.



CAUTION: If burner does not shut off during blowdown, immediately discontinue use of appliance and call for service.

Continue draining water for about fifteen (15) seconds, from control until water is clean. Manually close valve. Recheck gauge glass. If water level has dropped significantly, wait for the boiler to restore water level and pressure and repeat if necessary.

ADJUSTMENTS

At least twice a year have an authorized service person clean and adjust the unit for maximum performance.

7.0 MAINTENANCE (Continued)

BOILER DESCALING INSTRUCTIONS

It is recommended that the boiler should be checked every 90 to 120 days for scale build up. Regular maintenance should be carried out at this time.

If the boiler has been descaled, a new Anode should be installed in the boiler to help extend its life.

1. With boiler empty, close manual blowdown valve. If appliance is equipped with automatic blowdown, turn water supply OFF to appliance. Turn power switch ON. This will energize and close blowdown valve.
2. Remove 3/4" pipe plug from fitting on left front of boiler.
3. Insert appropriate hose or tube through fitting and pour in (½) half gallon (U.S.) of CLR Descaling Solution or use the Optional Deliming Assembly DPA-1 available from your dealer.

For appliances equipped with CSD-1, descaling solution must be introduced through hand hole.

4. Replace 3/4" pipe plug securely.
5. Open water supply to appliance allowing water to fill boiler to required level.
6. Let appliance cycle, allow two hours for descaling and cleaning. **DO NOT TURN STEAM ON TO THE COMPARTMENTS.**
7. Open both the blowdown and low water level control valves for complete drainage and then close both valves.

Appliance equipped with automatic blowdown - turn OFF power switch and open low water control valve. This will allow complete drainage. Once drained close water level control valve.

8. Turn appliance switch ON. When boiler is completely filled, turn power switch OFF. This will rinse and drain boiler. Appliance with manual blowdown valve must be opened to drain.
9. Complete Step 8 twice to assure boiler is completely rinsed.
10. Appliance is now ready for use.

7.0 MAINTENANCE (Continued)

TO CALIBRATE PRESSURE SWITCHES

NOTE: Pressure switches are factory set. Calibration is only required if pressure switches are replaced or if adjustment is required.

Pressure switch range is from 1 to 15 psi.

Adjust all settings to maximum on high signal adjustment screw on pressure switches.

Adjust in the following sequence:

- High limit pressure switch.
- Override pressure switch.
- Operating pressure switch.
- Turning screw clockwise to increase, counterclockwise to decrease pressure.
- Use relief valve to release pressure from boiler for setting adjustments.

1. HIGH LIMIT PRESSURE SWITCHES

Allow pressure to build until unit shuts off. This should occur at 15 psi. Set the high signal to switch at 14.5 psi on the gauge and the low signal to 13.0 psi.

2. OVERRIDE PRESSURE SWITCHES

Allow pressure to increase to 13 psi. Set the high signal to switch at 13 psi on the gauge and the low signal to 11 psi.

3. OPERATING PRESSURE SWITCHES

Set the high signal to switch at 11 psi on the gauge and the low signal to 9 psi.

4. Release pressure in boiler to below 9 psi. Burner will come on. Once pressure has reached 11 psi, burners will shut off. Repeat this process several times to make sure burners come on at 9 psi and shut off at 11 psi.

7.0 MAINTENANCE (Continued)

TO CALIBRATE PRESSURE SWITCHES (Continued)

Once completed, pressure switches have been calibrated.

Should your unit not have the High Limit pressure switch, start procedure at Override pressure switch.

SERVICE

Contact your local authorized service office for any repairs or adjustments needed on this equipment.

NOTICE: Contact the factory, the factory representative or local service company to perform maintenance and repairs.

8.0 TROUBLESHOOTING

COOKER:

DOOR HASP WILL NOT ENGAGE

1. Door loose and requires new bushings.
2. Hasp requires adjustment by adding or removing of washers under hasp.

HANDWHEEL HARD TO TURN

1. Foreign matter on thrust screw or lack of lubricant.
2. Thrust screw bent or worn.

DOOR GASKET LEAKS

1. Gasket screw loose.
2. Gasket damaged or at end of useful life.
3. Door loose and not aligned correctly.
4. Gasket plate installed incorrectly.
5. Handwheel binding so that not enough pressure to seal door.

WATER ACCUMULATES IN COMPARTMENTS

1. Appliance not levelled properly.
2. Compartment screen plugged.
3. Exhaust valve plugged or defective.
4. Exhaust drain line plugged.

COMPARTMENT PRESSURIZED AT END OF COOKING CYCLE

1. Exhaust valve plugged or defective.

8.0 TROUBLESHOOTING (Continued)

STEAM ESCAPES FROM COMPARTMENT DURING COOKING CYCLE

1. Compartment vent plugged.
2. Exhaust valve plugged or defective.

COOKING CYCLE CANNOT BE ACTIVATED

1. Loose wire terminations.
2. Steam valve plugged or defective.
3. Timer defective.
4. Micro switch on operation arm defective or requires adjustment.

WATER ENTERS COMPARTMENT THROUGH STEAM VALVE

1. Water level control defective or requires cleaning.

BOILER

At least twice a year have an authorized service person clean and adjust the unit for maximum performance.

WATER NOT BEING SUPPLIED TO BOILER

1. Water supply is "OFF".
2. Defective water fill solenoid.
3. Water level control clogged or defective, unable to operate fill valve.
4. Check drain valve is closed.
5. Supply water pressure too low.

8.0 TROUBLESHOOTING (Continued)

AUTOMATIC BLOWDOWN VALVE DOES NOT DRAIN

1. Defective blowdown valve.
2. Heat exchanger build up of scalant clogging drain lines and valve.

BOILER ACHIEVES PRESSURE SLOWER THAN NORMAL

1. Heavy build up of lime or scalant hampering heat transfer. Call for service to inspect interior of boiler. Should a considerable amount of scalant be found, have steam lines, water level control and valve also inspected.

SAFETY VALVE BLOWS

1. Defective safety valve.
2. Pressure too high, pressure switch requires adjustment (lower) or may be defective.

8.0 TROUBLESHOOTING (Continued)

BURNERS PRODUCE CARBON DEPOSITS

1. Wrong size orifices.
2. Burner air not adjusted properly.
3. Wrong gas supply.
4. Incorrect pressure at supply.

BURNERS DO NOT COME ON

1. Gas supply to unit is "OFF".
2. Manual shut off valve is "OFF".
3. Pilot is out.
4. Power supply is "OFF".
5. Water level has not been reached. Check water supply and water level control.
6. Pilot may require flame adjustment on option electronic ignition units.
7. If water at proper level, check relay which energizes pressure switch and gas valve.
8. Pressure switch may need to be replaced if relay is operating.
9. Check gas control. If energized but not operating, have replaced.

8.0 TROUBLESHOOTING (Continued)

PILOT LIGHT DOES NOT IGNITE (ELECTRONIC IGNITION)

1. Gas control knob is in "OFF" position.
2. Loose or dirty wire connection to ignition module, clean/or tighten.
3. Ignition cable shorting out. Check that it is not in contact with metal or damaged.
4. Defective ignition module.
5. Unit is 100% lock out. Turn off and try in five minutes.
6. Dirty flame sensor. Clean with emery cloth.
7. Pilot burner/ignitor sensor, cracked ceramic insulator. Have replaced.
8. Check for too much draft in room.