



IMPORTANT FOR FUTURE REFERENCE

Please complete this information and retain this manual for the life of the equipment:

Model #: _____

Serial #: _____

Date Purchased: _____

INSTALLATION & OPERATION MANUAL

Electric Tilting Skillets ETS-30 ETS-40

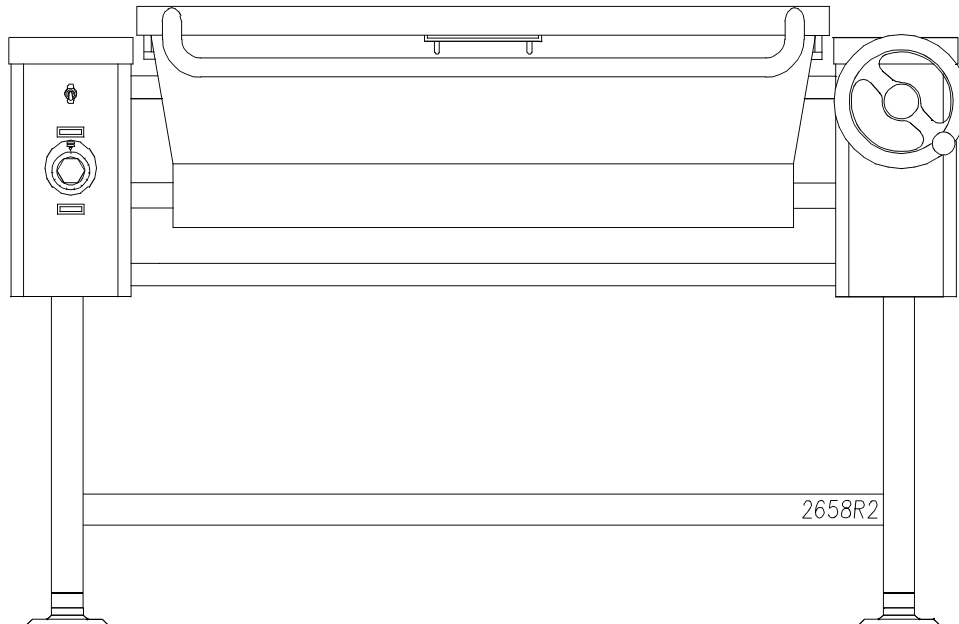

 **WARNING**

Improper installation, adjustment, alteration, service or maintenance can cause property damage, injury or death. Read the installation, operating and maintenance instructions thoroughly before installing or servicing this equipment.

CROWN FOOD SERVICE EQUIPMENT

 A Middleby Company

70 Oakdale Road, Downsview (Toronto) Ontario, Canada, M3N 1V9

Telephone: 919-762-1000 www.crownsteamgroup.com

Printed in Canada



INSTALLATION AND OPERATION MANUAL, ELECTRIC TILTING SKILLETS,
MODELS: ETS-30, ETS-40

INSTALLATION AND OPERATION

It is recommended that this manual be read thoroughly and that all instructions be followed carefully.



WARNING: This is the safety alert symbol. It is used to alert you to potential personal injury hazards. Obey all safety messages that follow this symbol to avoid possible injury or death.



WARNING: Improper installation, operation, adjustment, alteration, service or maintenance can cause property damage, injury or death. Read the installation, operating and maintenance instructions thoroughly before installing, operating or servicing this equipment.

NOTICE: Contact the factory, the factory representative or local service company to perform maintenance and repairs.

This manual should be retained for future reference.

Adequate clearances must be maintained for safe and proper operation.

INSTALLATION AND OPERATION MANUAL, ELECTRIC TILTING SKILLETS,
MODELS: ETS-30, ETS-40

TABLE OF CONTENTS

DESCRIPTION	PAGE
Service Connections	4
1.0 Installation Instructions	5
2.0 Operation	6
3.0 Cooking Schedule	7
4.0 Cleaning Instructions	11
5.0 Troubleshooting	12
6.0 Periodic Maintenance	12

INSTALLATION AND OPERATION MANUAL, ELECTRIC TILTING SKILLETS, MODELS: ETS-30, ETS-40

SERVICE CONNECTIONS

- ⚡ - Electrical connection to be as specified on data plate.
- 💧 - COLD WATER: 3/8" O.D. tubing to faucet (OPTIONAL)
- 🔥 - HOT WATER: 3/8" O.D. tubing to faucet (OPTIONAL)

ELECTRICAL CHARACTERISTICS

Available kW			AMPS PER LINE								
MODEL	STD.	OPT.	kW	PHASE	208V	220V	240V	380V	415V	480V	
ETS-30	18	12	12	1	57.7	54.5	50.0	N/A	N/A	N/A	
				3	33.3	31.5	28.9	18.2	16.7	14.4	
ETS-40	27	18		1	86.5	81.8	75.0	N/A	N/A	N/A	
				3	50.0	47.2	43.3	27.3	25.0	21.7	
MIN. CLEARANCE				18	1	86.5	81.8	75.0	N/A	N/A	N/A
SIDES	6 [152]				3	50.0	47.2	43.3	27.3	25.0	21.7
BACK	6 [152]		27		3	75.0	70.9	65.0	41.0	37.6	32.5

DIMENSIONS

MODEL	SHIPPING WT.	CAPACITY	UNITS	A	B	C	D	E	F	G		H	
										Ø2	Ø3	Ø2	Ø3
ETS-30	501 lbs. [228 kg]	30 U.S. gal. 114 litres	inches mm	49.75	32.88	23.50	43.13	9.25	67.63	39	43.5	10.63	11.13
				1264	835	597	1095	235	1718	991	1105	270	283
ETS-40	547 lbs. [248 kg]	40 U.S. gal. 152 litres	inches mm	59	42.88	23	52.50	9.25	67.5	38.75	43.25	10.25	10.75
				1499	1089	584	1334	235	1715	984	1099	260	273

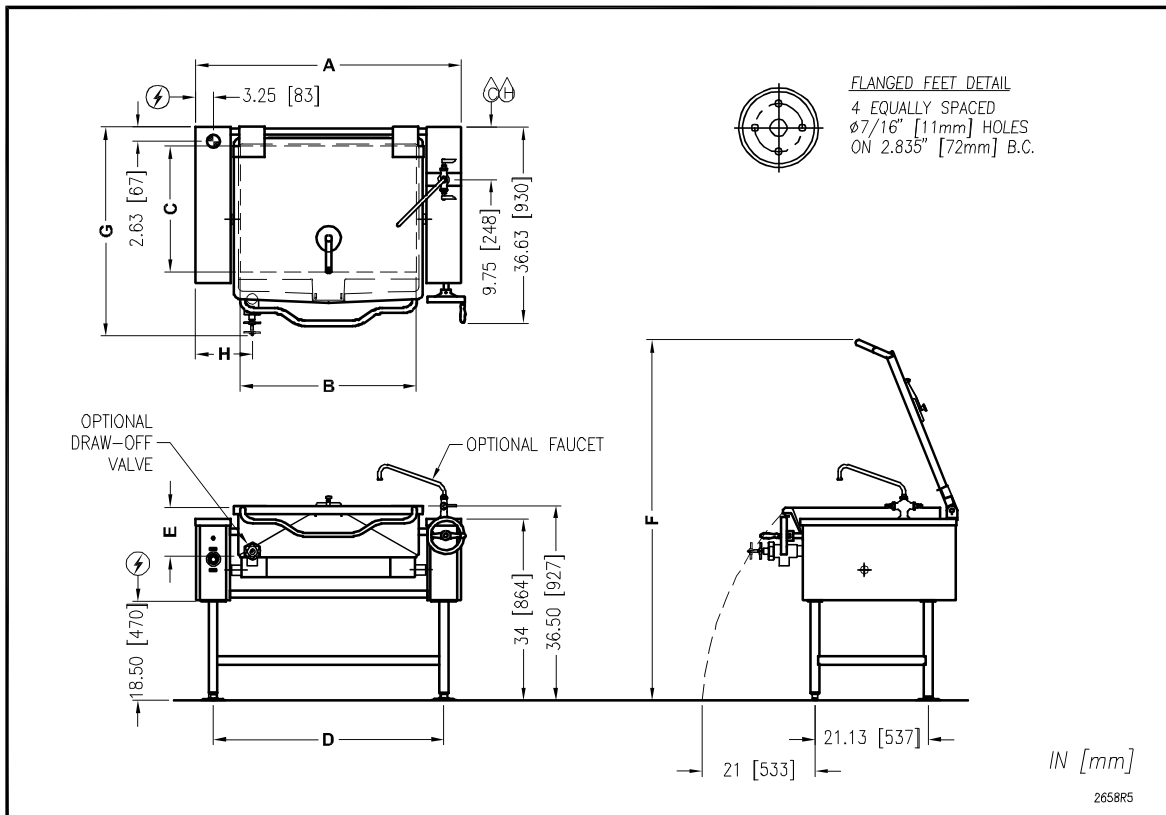

As continued product improvement is a policy of Crown, specifications are subject to change without notice.

INSTALLATION AND OPERATION MANUAL, ELECTRIC TILTING SKILLETS,
MODELS: ETS-30, ETS-40

1.0 INSTALLATION INSTRUCTIONS

Set skillet in place and level appliance using spirit level. Mark hole locations on floor through anchoring holes provided in flanged adjustable feet.

Remove appliance and drill holes in locations marked on floor and insert proper anchoring devices.

Re-level the appliance, leveling the unit left to right and front to back.

Bolt and anchor appliance securely to the floor. Seal bolts and flanged feet with Silastic or equivalent compound.

SERVICE CONNECTIONS

All internal wiring for the skillet is complete.

Make service connections as indicated on page 4.

This must be a waterproof connection from incoming lines.

Ground skillet to terminal provided in control housing. A wiring diagram is provided and is located inside the control cover panel.

If faucet is provided connect water supply and check for proper operation.



WARNING: If this appliance is equipped with casters, the installation shall be made with flexible power supply conduit and adequate means must be provided to limit the movement of the appliance without depending on, or transmitting stress, to the electrical conduit; restraining means may be attached to the bracket near the entry of the power supply connection on the appliance.

If the unit is also equipped with an optional water fill valve it too must be installed with a flexible water supply tube, a quick disconnect and strain relief.

INSTALLATION AND OPERATION MANUAL, ELECTRIC TILTING SKILLETS,
MODELS: ETS-30, ETS-40

2.0 OPERATION

Ensure the power supply is connected to unit and that circuit breakers are on.

Tilt skillet to ascertain that it moves easily. Turn handle as far as it will go and return to upright position.

Turn power switch "ON". Set thermostat dial to desired temperature. Preheat skillet and allow it to cycle several times to equalize the heat across entire pan surface. Cooking will occur faster with the cover down.

At the end of cooking turn thermostat to "OFF", turn power switch "OFF", remove product.

NOTE: The skillet is equipped with a safety switch that is activated when the pan is tilted. In the tilted position, power supply to the heating elements is interrupted. The unit can only be operated in the down position.



WARNING: Never tilt pan with cover down.



WARNING: When this appliance is installed with casters, a restraint to prevent damage to the power supply conduit should have been installed. If disconnection of the restraint is necessary, reconnect this restraint after the appliance has been returned to its originally installed position.

INSTALLATION AND OPERATION MANUAL, ELECTRIC TILTING SKILLETS,
MODELS: ETS-30, ETS-40

3.0 COOKING SCHEDULE

The tilting skillet is one of the most versatile pieces of equipment to be found in any restaurant or institutional kitchen. It enables the cook to stew, simmer, pan fry, braise, grill or sauté and all with a very uniform heat pattern. The figures given below are suggested quantities and temperature settings and estimated numbers of orders per load and per hour. When two temperatures are given, first is to start the product, second to finish the product.

The following temperatures should be used:

Simmering	Maximum of 200°F	Thermostat Setting 1 - 4
Sautéing	225 - 275°F	Thermostat Setting 5 - 6
Searing	300 - 350°F	Thermostat Setting 7 - 8
Frying	325 - 375°F	Thermostat Setting 8 - 9
Grilling	350 - 425°F	Thermostat Setting 9 -10

<u>ITEM</u>	<u>PORTION SIZE</u>	<u>THERMOSTAT SETTINGS</u>	<u>BATCHES PER HOUR</u>	<u>ETS-30 PER LOAD</u>		<u>ETS-40 PER LOAD</u>	
				<u>QTY</u>	<u>YIELD</u>	<u>QTY</u>	<u>YIELD</u>
BREAKFAST FOODS							
Bacon	3 Slices	350° F	12	2	10	3	15
Eggs							
Boiled Hard	1 Egg	225° F	5	50	50	75	75
Boiled Soft	1 Egg	225° F	8	50	50	75	75
Fried	1 Egg	400° F	4	30	30	45	45
Poached	1 Egg	225° F	5	36	36	60	60
Scrambled	1 ½ Eggs	300° F 200° F	1	18 gal.	720	28 gal.	1100
French Toast	3 Slices	450° F	7	35 slices	12	50 slices	17
Regular Oatmeal	½ cup	250° F	2	20	500	40	1000
Pancakes	2 each	400° F	10	30 each	15	50 each	25
FISH							
Clams	1 pt.	400° F	10	10 quarts	20	15 quarts	30
Fish Cakes	2 - 3 oz.	400° F	5	70 - 3 oz.	35	110- 3 oz.	55
Haddock Fillet	4 oz.	400° F	4	60 - 4 oz.	60	90 - 4 oz.	90

INSTALLATION AND OPERATION MANUAL, ELECTRIC TILTING SKILLETS,
MODELS: ETS-30, ETS-40

<u>ITEM</u>	<u>PORTION SIZE</u>	<u>THERMOSTAT SETTINGS</u>	<u>BATCHES PER HOUR</u>	<u>ETS-30 PER LOAD</u>		<u>ETS-40 PER LOAD</u>	
				<u>QTY</u>	<u>YIELD</u>	<u>QTY</u>	<u>YIELD</u>
Halibut Steak	5 oz.	450° F	3	60 - 4 oz.	60	90 - 4 oz.	90
Lobster	1 - 1 lb.	350° F	4	20 - 1 lb.	20	30 - 1 lb.	30
Swordfish	5 oz.	450° F	3	50 - 5 oz.	50	75 - 5 oz.	75
SAUCES							
Brown Gravy	1 oz.	350° F - 200° F	2	18 gals.	2300	35 gals.	4500
Cream Sauce	2 oz.	250° F - 175° F	1	18 gals.	1150	35 gals.	2250
Cream Soup	6 oz.	200° F	1	18 gals.	375	35 gals.	725
French Onion Soup	6 oz.	225° F	1	18 gals.	350	35 gals.	700
Meat Sauce	4 oz.	350° F - 200° F	1	18 gals.	575	35 gals.	1100
MEAT - POULTRY							
Bacon	3 slices	350° F	12	2 lb.	10	3 lb.	15
Beef							
American Chop Suey	6 oz.	400° F - 225° F	2	18 gals.	350	35 gals.	700
Beef Stew	8 oz.	300° F	--	18 gals.	280	35 gals.	560
Corned Beef Hash	5 oz.	400° F	5	16 lb.	50	25 lb.	75
Cheeseburger	3 oz.	300° F	12	7 lb.	35	10 lb.	50
Hamburger	3 oz.	300° F	15	7 lb.	35	10 lb.	50
Meatballs	1 oz.	400° F - 225° F	3	12 ½ lb.	65	18 lb.	100
Pot Roast	2 oz.	350° F - 200° F		120 lb.	500	180 lb.	750
Salisbury Steak	5 oz.	400° F	3	16 lb.	50	24 lb.	75
Sirloin Steak	6 oz.	400° F	5	15 lb.	40	22 ½ lb.	60
Swiss Steak	4 oz.	300° F - 200° F	1	25 lb.	100	40 lb.	160

INSTALLATION AND OPERATION MANUAL, ELECTRIC TILTING SKILLETS,
MODELS: ETS-30, ETS-40

<u>ITEM</u>	<u>PORTION SIZE</u>	<u>THERMOSTAT SETTINGS</u>	<u>BATCHES PER HOUR</u>	<u>ETS-30 PER LOAD</u>		<u>ETS-40 PER LOAD</u>	
				<u>QTY</u>	<u>YIELD</u>	<u>QTY</u>	<u>YIELD</u>
Chicken							
Pan Fried	2-1/4's	350° F	3	50 pieces	25	80 pieces	40
Whole	2 oz.	350° F - 200° F		16 - 5 lb.	200	24 - 5 lb.	265
Frankfurters							
Grilled	2 oz.	300° F	8	22 lb.	176	33 lb.	264
Boiled	2 oz.	250° F	12	16 lb.	128	25 lb.	200
Ham Steak	3 oz.	400° F	8	10 lb.	50	15 lb.	75
Pork Chops	5 oz.	350° F	4	15 lb.	50	25 lb.	75
Sausage Links	3 links	350° F	7	30 lb.	120	45 lb.	180
Turkey							
Off Carcass	2 oz.	400° F - 200° F	--	3 - 26 - 30 lb.	200	4 - 26 - 30 lb.	275
On Carcass	2 oz.	400° F - 200° F	--	4 - 16 - 20 lb.	175	6 - 16 - 20 lb.	265
MISCELLANEOUS							
Grilled Chicken	1 Sandwich	400° F	8	35 Sand.	35	50 Sand.	50
Macaroni & Cheese	8 oz.	200° F	2	18 gals.	300	35 gals.	525
Rice	4 oz.	350° F - 225° F	1	20 lb. raw	320	40 lb.	650
Spaghetti	4 oz.	350° F - 225° F	2	8 lb. raw	200	12 lb.	300
VEGETABLES							
Canned	3 oz.	400° F	6	30 lb.	125	45 lb.	200
Fresh							
Beans, Wax, Green	3 oz.	400° F	3	25 lb.	125	50 lb.	250
Beets	3 oz.	400° F	1	30 lb.	125	60 lb.	300
Broccoli	3 oz.	400° F	3	25 lb.	125	40 lb.	200

INSTALLATION AND OPERATION MANUAL, ELECTRIC TILTING SKILLETS,
MODELS: ETS-30, ETS-40

<u>ITEM</u>	<u>PORTION SIZE</u>	<u>THERMOSTAT SETTINGS</u>	<u>BATCHES PER HOUR</u>	<u>ETS-30 PER LOAD</u>		<u>ETS-40 PER LOAD</u>	
				<u>QTY</u>	<u>YIELD</u>	<u>QTY</u>	<u>YIELD</u>
Cabbage	3 oz.	400° F	5	20 lb.	80	30 lb.	125
Carrots	3 oz.	400° F	2	35 lb.	150	70 lb.	300
Cauliflower	3 oz.	250° F	5	15 lb.	75	25 lb.	125
Corn	1 Ear	400° F	8	50 Ears	50	75 Ears	75
Potatoes	3 oz.	400° F	2	40 lb.	200	60 lb.	300
Spinach	4 oz.	250° F	10	6 lb.	25	9 lb.	35
Turnip	4 oz.	400° F	2	20 lb.	100	30 lb.	150
Frozen							
Beans, French Green	3 oz.	400° F	6	15 lb.	60	22 ½ lb.	90
Lima Beans	3 oz.	250° F	4	15 lb.	60	22 ½ lb.	90
Broccoli	3 oz.	400° F	8	12 lb.	50	18 lb.	75
Sliced Carrots	3 oz.	250° F	6	15 lb.	60	22 ½ lb.	90
Small Whole Carrots	3 oz.	250° F	3	15 lb.	50	22 ½ lb.	90
Corn	3 oz.	250° F	18	15 lb.	50	22 ½ lb.	90
Small Whole Onions	3 oz.	250° F	7	15 lb.	50	22 ½ lb.	90
Peas	3 oz.	400° F	10	15 lb.	75	22 ½ lb.	110
Spinach	3 oz.	400° F	3	15 lb.	75	22 ½ lb.	110
DESSERTS, PUDDINGS, SWEET SAUCES							
Butterscotch Sauce	1 oz.	200° F	1	18 gals.	2300	35 gals.	4500
Cherry Cobbler	3 oz.	200° F	1	18 gals.	750	35 gals.	1500
Chocolate Sauce	1 oz.	200° F	1	18 gals.	2300	35 gals.	4500
Cornstarch Pudding	4 oz.	200° F	1	18 gals.	575	35 gals.	1100
Fruit Gelatin	3 oz.	250° F	2	18 gals.	750	35 gals.	1500

INSTALLATION AND OPERATION MANUAL, ELECTRIC TILTING SKILLETS,
MODELS: ETS-30, ETS-40

4.0 CLEANING INSTRUCTIONS

NOTICE: As a safety precaution disconnect the power supply during cleaning and servicing.

The Electric Tilting Skillet should be cleaned after each use.

Soak cooking surface with water and a mild soap to remove any food stuck to surface.

Wash entire unit surface with mild detergent and water. Rinse entire unit and dry.



WARNING: Do not get water in electrical components.

Ensure that pour spout, strainer, cover and sides of unit are also cleaned.

INSTALLATION AND OPERATION MANUAL, ELECTRIC TILTING SKILLETS,
MODELS: ETS-30, ETS-40

5.0 TROUBLESHOOTING

Unit will not operate:

1. Power supply not "ON".
2. Pan not in down position.
3. Defective thermostat or elements.

Pan difficult to operate:

1. Unit not level.
2. Thrust bearings worn out.
3. Dirt in bearings causing it to bind.
4. Shaft bent.

6.0 PERIODIC MAINTENANCE

1. Grease tilt worm and gear as required. Use Petro-Canada type 0G-2 or equivalent.
2. Grease pivot bearings via lubricating nipple as required.
3. Check that screws in element terminals are not loose. Loose connections may cause arcing and burn off connection causing element failure.