

Target National Account

EnergyX[®] System

Factory Installed Energy Recovery
48/50HC WeatherMaster[®] Commercial Rooftop Units
12.5 Nominal Ton Units
with Puron[®] (R-410A) Refrigerant
and I/O Flex 6126 Controls



turn to the experts 

Supplemental Installation Instructions

This document is a supplemental installation instruction for Target rooftop units with the EnergyX factory installed Energy Recovery Ventilator. It is to be used with the base HC 12.5 Ton rooftop unit Installation Instructions.

NOTE: Read the entire instruction manual before starting the installation

TABLE OF CONTENTS

SAFETY CONSIDERATIONS	2	ERV (DCV) Mode —	14
GENERAL	3	Exhaust Control	15
INSTALLATION	5	TROUBLESHOOTING	15
Install Roofcurb	5	Complete ERV Stoppage	15
Vertical Airflow Configurations	5	On-board Pressure Transducers	15
Horizontal Airflow Configurations	5	EnergyX Control Board LEDs	15
Rig and Place Unit on Curb	5	MAJOR SYSTEM COMPONENTS	15
Install Hold Down Brackets	5	EnergyX Control Board (EXCB)	18
Positioning	6	Enthalpy Wheel	19
Outside Air Hood Installation	8	Modulating Fan	19
Exhaust Air Hood Installation	8	Options and Accessories	19
Make Electrical Connections	9	Frost Protection (factory-install only)	19
Main Power	9	Wheel Motor Status (field install only)	19
Control Power	9	SERVICE & MAINTENANCE	20
Base Unit Components	9	Cleaning	20
START UP	9	Wheel and Segment Cleaning	20
Start-Up Check List	9	Filters	20
Base Unit Evaporator Fan	9	Outdoor-Air Inlet Screens	20
OPERATING SEQUENCE	9	Lubrication	20
General	9	Wheel Drive Adjustment	20
Communications	9	Wheel Air Seal Adjustment	20
12.5 Ton Modulating ERV	13	Wheel and Segment Removal/Installation	21
Occupancy	14	Wheel Segment Removal/Installation	21
Modes of Operation	14	Whole Wheel Removal/Installation (36" wheels) ..	22
Off Mode —	14	Outside Air and Exhaust Hood Removal	23
Test Mode —	14	Outside Air Hood Removal	23
Defrost Mode —	14	Exhaust Air Hood Removal	24
		Outside Air and Exhaust Fan Replacement	24
		Outside Air Fan Removal	24
		Exhaust Fan Removal	26

APPENDIX 28

Appendix A — Certified Dimension Drawings 29

Appendix B — Exhaust Fan Performance 33

 EnergyX Modulating Volume 12.5 Ton Unit 33

Appendix C — Electrical Data 34

 Table 8 - 48HC with ERV:
 Unit Wire/Fuse or HACR Breaker Sizing Data 34

 Table 9 - 48HC with ERV and Factory-Installed
 HACR Breaker 35

 Table 10 - 48HC with ERV and
 2-Speed Indoor Fan Option 36

 Table 11 - 48HC with ERV,
 Factory-Installed HACR Breaker and
 2-Speed Indoor Fan Option 37

 Table 12 - 50HC with Electric Heat and ERV:
 Unit Wire/Fuse or HACR Breaker Sizing Data 38

 Table 13 - 50HC with Electric Heat, ERV and
 Factory-Installed HACR Breaker 40

 Table 14 - 50HC with Electric Heat, ERV
 and 2-Speed Indoor Fan Option 42

 Table 15 - 50HC with Electric Heat, ERV,
 Factory-Installed HACR Breaker and
 2-Speed Indoor Fan Option 44

Appendix D — I/O Flex 6126 Controller 47

Appendix E — Carrier BACview/Virtual BAC view
Commissioning 57

ENERGYX UNIT START-UP CHECKLIST 63

SAFETY CONSIDERATIONS

Improper installation, adjustment, alteration, service, maintenance, or use can cause explosion, fire, electrical shock or other conditions which may cause personal injury or property damage. Consult a qualified installer, service agency, or your distributor or branch for information or assistance. The qualified installer or agency must use factory-authorized kits or accessories when modifying this product. Refer to the individual instructions packaged with the kits or accessories when installing.

Follow all safety codes. Wear safety glasses and work gloves. Use quenching cloths for brazing operations and have a fire extinguisher available. Read these instructions thoroughly and follow all warnings or cautions attached to the unit. Consult local building codes and appropriate national electrical codes (in USA, ANSI/NFPA70, National Electrical Code (NEC); in Canada, CSA C22.1) for special requirements.

It is important to recognize safety information. This is the safety-alert symbol . When you see this symbol on the unit and in instructions or manuals, be alert to the potential for personal injury.

Understand the signal words DANGER, WARNING, CAUTION, and NOTE. These words are used with the safety-alert symbol.

DANGER identifies the most serious hazards which **will** result in severe personal injury or death. WARNING signifies hazards which **could** result in personal injury or death.

CAUTION is used to identify unsafe practices, which **may** result in minor personal injury or product and property damage.

NOTE is used to highlight suggestions which **will** result in enhanced installation, reliability, or operation.

WARNING

ELECTRICAL SHOCK HAZARD

Failure to follow this warning could cause personal injury or death.

Before performing service or maintenance operations on unit, always turn off main power switch to unit and install lock(s) and lockout tag(s). Unit may have more than one power switch. Ensure electrical service to rooftop unit agrees with voltage and amperage listed on the unit rating plate.

CAUTION

UNIT DAMAGE HAZARD

Failure to follow this caution may cause equipment damage.

This unit uses a microprocessor-based electronic control system. Do not use jumpers or other tools to short out components or to bypass or otherwise depart from recommended procedures. Any short-to-ground of the control board or accompanying wiring may destroy the electronic modules or electrical components.

CAUTION

CUT HAZARD

Failure to follow this caution may result in personal injury.

Sheet metal parts may have sharp edges or burrs. Use care and wear appropriate protective clothing, safety glasses and gloves when handling parts and servicing air conditioning equipment.

GENERAL

This publication contains Installation, Start-Up, Controls, Operation, Troubleshooting and Service information for the EnergyX Energy Recovery System, factory installed on a 48/50HC (12.5 nominal ton) rooftop unit. This document is a supplemental installation instruction and is to be used in conjunction with the base rooftop unit Installation Instructions.

The EnergyX Energy Recovery system is designed to pre-condition the outside air prior to it entering the rooftop unit evaporator using building exhaust air as a heat sink / source. The EnergyX system provides latent and sensible energy exchange between the outside ventilation air and the building exhaust air. This preconditioning of air allows higher operating efficiencies, increased comfort control, potential downsizing of the base rooftop unit while still meeting the ASHRAE ventilation requirements. Operational cost savings are realized by the high efficiency Energy Recovery device meeting the cooling and heating call for a larger portion of the operating cycle than just a normal damper or economizer device. This is demonstrated by the EnergyX AHRI Guideline-V Combined Efficiency Factor.

EnergyX HC14 units are shipped in the vertical supply and return duct configurations only. A field installed horizontal curb adapter kit is available for horizontal return and supply configuration.

The EnergyX Energy Recovery Wheel is rated in accordance with AHRI 1060 and is UL listed.

See Table 1 for Physical Data.

Physical Data

Table 1 – Physical Data

Model	48/50HC Size 14 (12.5 Ton)
EnergyX Unit Type	Modulating Air Flow Capability
ERV WHEEL OA (CFM)	1,875
ERV WHEEL EA (CFM)	1,550
ENERGY RECOVERY WHEEL	
TYPE	Enthalpy Lightweight Polymer with Silica Gel Desiccant Coating
MODEL (AirXchange)	ERC-3019C
SIZE (Dia. X Depth) (in.)	30–in x 3–in
NOMINAL DRIVE MOTOR HP	0.1
SUPPLY FAN #1	
QTY - TYPE	1 - Impeller
DRIVE TYPE	Direct
BLOWER SIZE (DIAMETER)	15.74 – in (400mm)
NOMINAL MOTOR HP	1.179
EXHAUST FAN #1	
QTY - TYPE	1 - Impeller
DRIVE TYPE	Direct
BLOWER SIZE	19.68 – in (500mm)
NOMINAL MOTOR HP	3.619
FILTERS	
TYPE	2-in. Pleated, 30% Efficiency
SUPPLY AIR (QTY) - SIZE	(2) 16–in x 20–in x 2–in
EXHAUST AIR (QTY) - SIZE	(2) 16–in x 20–in x 2–in
TYPE	Aluminum Water Filter
Water Entrapment (QTY) - SIZE	(1) 48.219–in x 17.15–in x 1–in

EnergyX

INSTALLATION

An EnergyX unit is installed as a single piece unit. To install an EnergyX unit, follow the base rooftop unit installation instructions with the following exceptions and additions:

Install Roofcurb

Vertical Airflow Configurations —

The EnergyX unit uses the standard HC base unit roofcurb. No extra curb support rails or extensions are required. See the unit nameplate for model number designation. Refer to the base rooftop installation manual and “Install Hold Down Brackets” below for roofcurb instructions. Ductwork must be attached to the curb.

Rig and Place Unit on Curb

Inspect the EnergyX system for damage. File a claim with the shipping company if shipment is incomplete or damaged.

⚠ CAUTION

UNIT DAMAGE HAZARD

Failure to follow this caution may result in equipment damage.

All panels must be in place when rigging. Unit is not designed for handling by fork truck.

Install Hold Down Brackets —

Target curbs and curb adapters include hold down brackets provided by the roof curb manufacturer. Brackets must be installed on curb and attached to unit base rails. See Fig. 1 for details

If using EnergyX unit with a curb adapter, the curb adapter must be secured to existing curb, and the curb adapter secured to the unit with hold down brackets.

NOTE: Hold down brackets must be affixed to the curb and rooftop unit prior to removing rigging support.

See the rigging label on the exterior of the base unit and Fig. 2. This label is provided for guidance purposes **ONLY**. The unit’s actual weight and center of gravity will vary based on the specific combination of factory options included with the unit. Use prudent judgment when rigging and lifting the unit to account for weight variances and make adjustments for the actual center of gravity as necessary.

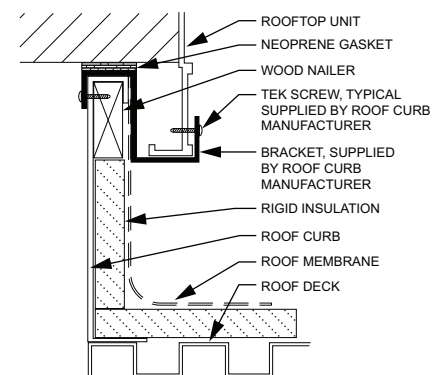
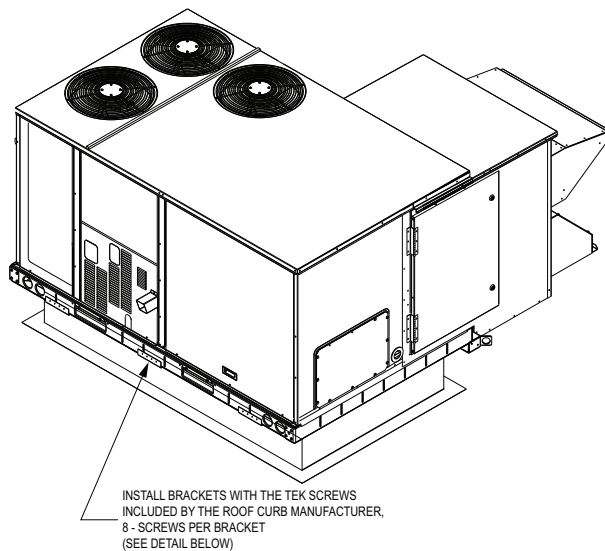
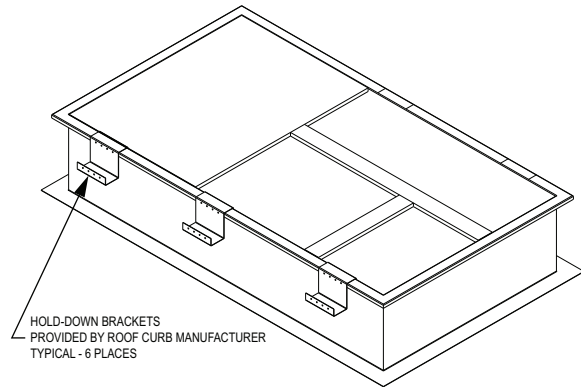
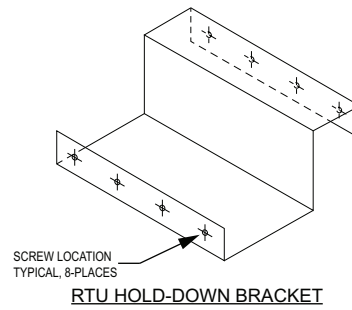

DETAIL: RTU HOLD-DOWN BRACKET INSTALLATION

Fig. 1 - SRT ERV Hold Down Brackets — Location and Installation

C13080



⚠ CAUTION - NOTICE TO RIGGERS: ⚠ AVERTISSEMENT - REMARQUE À L'ATTENTION DES MONTEURS

ALL PANELS MUST BE IN PLACE WHEN RIGGING.
TOUS LES CAPOTS DOIVENT ÊTRE EN PLACE AVANT LE LEVAGE

- Hook rigging shackles through holes in base rail and rigging bracket, as shown in Detail "A" and "B".
- Use wooden top skid, when rigging, to prevent rigging straps from damaging unit.
- Accrochez les manilles aux trous de la traverse de base et du support de gréement tel que montré aux dessins de détail "A" et "B".
- Utiliser des cales en bois lors du levage pour éviter que les élingues n'endommagent le haut de l'appareil.

914-1371 (36"-54")

"B"

"A"

"B"

"A"

SEE DETAIL B
VOIR DÉTAIL «B»

SEE DETAIL A
VOIR DÉTAIL «A»

PLACE ALL SEAL STRIP IN PLACE BEFORE PLACING UNIT ON ROOF CURB
INSTALLER TOUTES LES BANDES D'ISOLATION EN PLACE AVANT DE PLACER L'APPAREIL SUR LE REBORD DE TOIT.

DUCT END PASSAGES CONDUITES

DETAIL "A"
DÉTAIL «A»

DETAIL "B"
DÉTAIL «B»

UNIT	MAX. WEIGHT POIDS MAXIMUM		A		B		C		
	LB	KG	IN	MM	IN	MM	IN	MM	
	LIVRES	KG	PO	MM	PO	MM	PO	MM	
48HC D14 W/ERV	2710	1232	116.0	2945	73.4	1864	59.5	1510	
50HC D14 W/ERV	2640	1200	116.0	2945	73.4	1864	59.5	1510	
48HC**14****-T	2659	1208	116.0	2945	73.1	1856	59.5	1510	
50HC**14****-T	2589	1177	116.0	2945	73.1	1856	59.5	1510	
								50TM501706	B

NOTE: Units with "*****-T" in the model number are for Target only!

Fig. 2 - Rigging Label, 48-50HC Size 14 Units With ERV

C12813

Positioning

Maintain unit clearances as listed as shown in Fig. 3 for minimum distance from combustible materials, proper airflow, and service access. Follow all local codes for proper clearances – the local code requirements take precedence over any clearance listed in this document. Contact your local Carrier representative for clearance obstructions and any potential resulting affect on unit warranty.

Follow all other curb, rigging, and positioning installation guidance in base rooftop unit installation instructions.

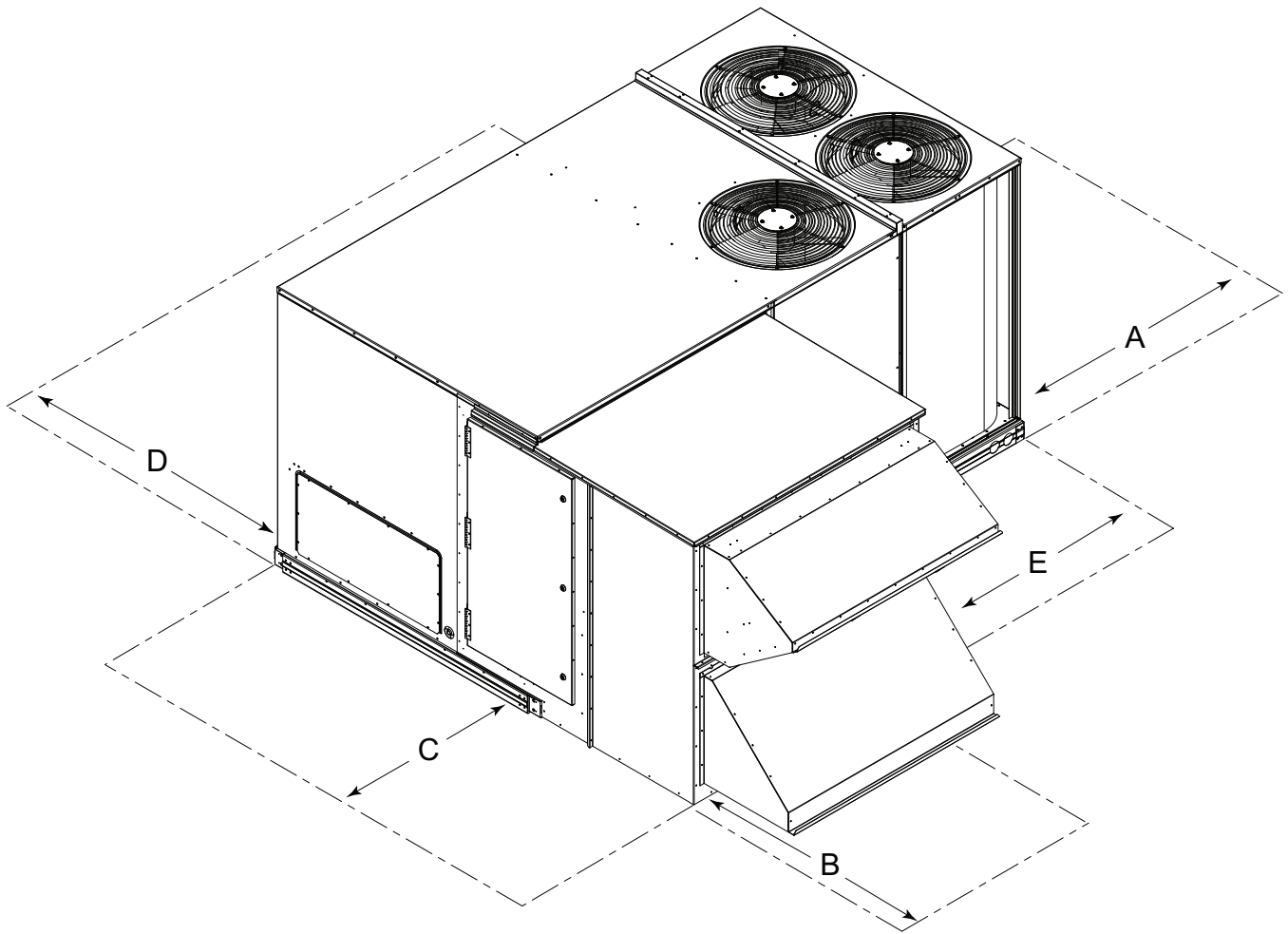

C13081

LOCATION	DIMENSION	CONDITION
A	48-in (1219 mm) 18-in (457 mm) 18-in (457 mm) 12-in (305 mm)	Unit disconnect is mounted on panel No disconnect, convenience outlet option Recommended service clearance Minimum clearance
B	36-in (914 mm)	Recommended service clearance
C	54-in (1372 mm)	Recommended service clearance
D	48-in (1219 mm) 42-in (1067 mm) 36-in (914 mm) Special	No flue discharge accessory installed, surface is combustible material Surface behind servicer is grounded (e.g., metal, masonry wall, another unit) Surface behind servicer is electrically non-conductive (e.g., wood, fiberglass) Check for adjacent units or building fresh air intakes within 10-ft (3 m) of this unit's flue outlet
E	36-in (914 mm)	Recommended service clearance

NOTE: Unit not designed to have overhead obstruction. Contact Application Engineering for guidance on any application planning overhead obstruction or for vertical clearances.

Fig. 3 - Clearances for ERV on Size 14 HC Base Units

Outside Air Hood Installation

1. Gasket the entire perimeter of the outside air hood along the flange using gasket provided.
2. Connect the green tubing from the hood to the top quick connect (labeled "HIGH").
3. Connect yellow tubing from the hood to the bottom quick connect (labeled "LOW").
4. Attach outside air hood to ERV by fastening the provided seal tek screws around the perimeter of the outside air hood (see Fig. 4).

Exhaust Air Hood Installation

1. Gasket the entire perimeter of the exhaust air hood along the flange using gasket provided.
2. Attach exhaust air hood to ERV by fastening the provided seal tek screws around the perimeter of the exhaust air hood (see Fig. 5).

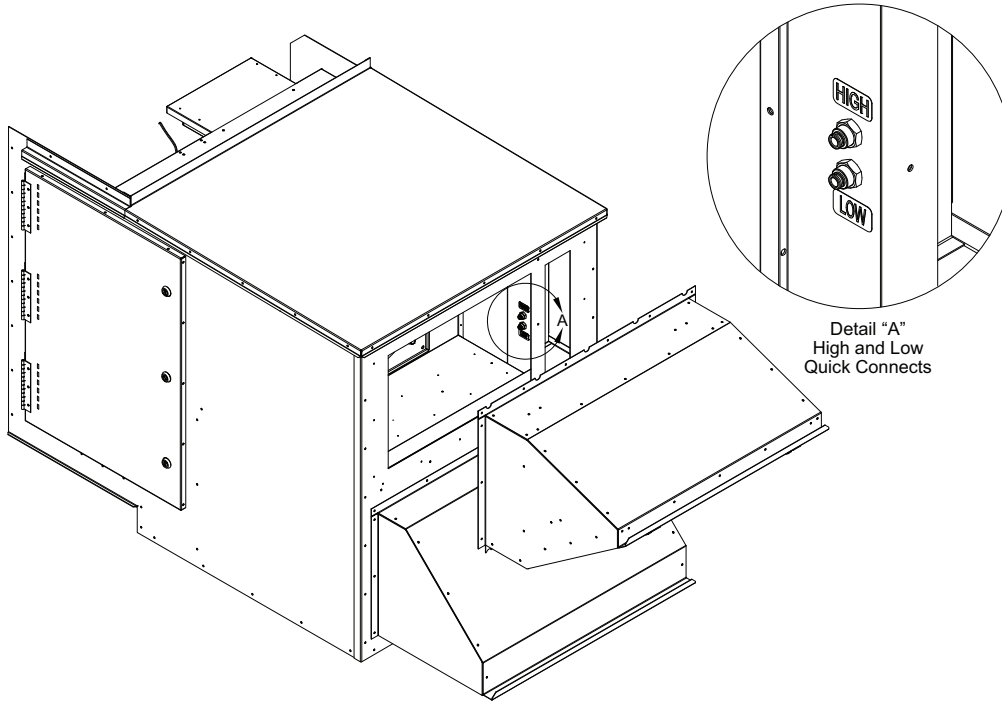

Fig. 4 - Outside Air Hood Installation

C11491

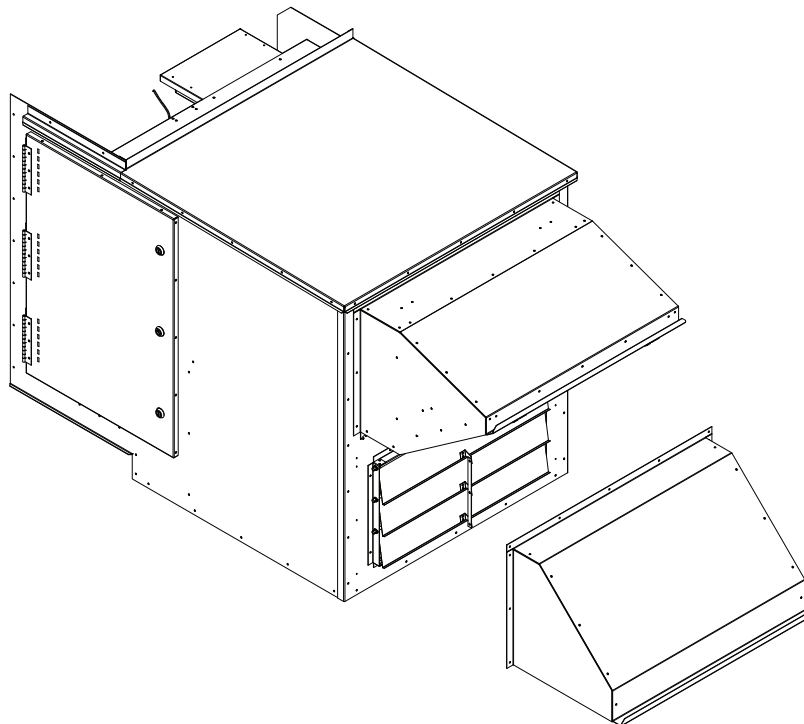

Fig. 5 - Exhaust Air Hood Installation

C13082

Make Electrical Connections

See the base unit name plate for the ETL certified singlepoint electrical values and component electrical information. See the base unit control box and EnergyX access doors for the electrical wiring diagrams specific to each section.

Main Power —

Follow all base unit installation instructions, using electrical values shown on unit nameplate; only one main power supply is required. The EnergyX base rooftop unit and energy recovery module is ETL listed as a single point power supply only.

On some voltage ERV's, there is a step down transformer that is factory supplied to power components that are not line side voltage. Field wiring or alteration of these components is neither required nor desired.

⚠ CAUTION

UNIT DAMAGE HAZARD

Failure to follow this caution may result in equipment damage.

Some electric heat modules require a dual-point electrical service connection independent from all other electrical circuits in the unit. Consult the unit installation instructions, unit wiring diagrams and/or electric heater installation instructions for verification.

Control Power —

Follow all base unit installation instructions for low voltage wiring. The ERV control board is factory wired into the base unit communications. All external control wires still connect to the RTU terminal strip as in the base unit installation instructions.

See Appendix D of this manual for details on connections for the I/O Flex 6126 controller.

Base Unit Components

Follow the base unit installation instructions to install all other base unit components, including (but not limited to) flue hoods, condensate trap and other accessory devices.

START UP

The EnergyX unit is operated in coordination with the base rooftop unit. Follow the base unit instructions and Controls book for proper start-up with addition of the following:

Start-Up Check List

Use the EnergyX Start-Up checklist (see page 59) in conjunction with the base unit Start-Up checklist from the

base Controls book. Fill in all blank data entries that are applicable to the exact unit being installed. The ERV model and serial numbers are printed in the ERV control box. Save the checklist for future service and maintenance use. It is recommended that a copy of the checklist be left with the unit in the literature slot on the base unit control box access door.

Base Unit Evaporator Fan

First follow the base unit instructions to balance the RTU indoor fan. The ERV fans should be off during base unit fan set-up. Before start-up and testing the ERV, verify that the minimum damper positions are set to 0 and if not change them to 0.

OPERATING SEQUENCE

General

An EnergyX unit is a 48/50HC rooftop unit and energy recovery ventilator (ERV). It operates the ERV module in an integrated manner with the base rooftop unit. The base rooftop unit functions per the base unit sequence of operation. The ERV will operate based on communication from the I/O Flex 6126 controller. The following section discusses the ERV operation in detail. In summary, the ERV operates to provide pre-conditioned outside air for ventilation requirements.

In general the ERV monitors occupancy and indoor fan state of the base unit to determine when to activate. The outside air fan bring in outside air which passes it through the enthalpy wheel and into the rooftop unit. The building return air is pulled through the enthalpy wheel by the exhaust fan and released outside. During operation the enthalpy wheel is rotating to use the building air to pre-condition the outside air.

IMPORTANT: Refer to Appendix D for details on the I/O Flex controller for the EnergyX system.

Communication

The ERV relies on communication with I/O Flex 6126 to operate. The ERV monitors I/O Flex 6126 points to determine operation. The ERV writes to values in I/O Flex 6126 to provide the user with its running status. If communication is lost the ERV will shut down and remain in the Off mode until communication is established. Refer to the troubleshooting section for details on communication failures. Table 2 shows the I/O Flex 6126 points that the ERV monitors for operation and a brief description of their functions. Table 3 shows the I/O Flex 6126 points that the ERV uses for its configurations and a brief description of each. Table 4 shows the I/O Flex 6126 points that the ERV writes to based on its running status.

Table 2 – Inputs - Points the ERV Read

Value	Expanded Text	Range	Units	Default	Function
NVO_MODE	nvoUnitStatus.mode	xxxx			Determine what mode RTU is in
OCCUPIED	Currently Occupied	No/Yes			Determine if RTU is occupied
IDFSTATE	Indoor Fan State	Off/On			Determine if the RTU indoor fan is running
FANSPEED	Commanded Fan Speed	xxx	%		Determine if the RTU indoor fan is running
IAQ	IAQ Level (sensor)	xxxx			Space CO2 sensor level (PPM)
IAQIN	IAQ Level (switch)	Low/High			Determine if CO2 is high or low
SAT	Supply Air Temperature	xxx.x	° F		RTU supply air temp
OA_TEMP	Outdoor Air Temperature	xxx.x	° F		RTU Outdoor Temp
SPACE_T	Space Temperature	xxx.x	° F		Building Space Air Temp
RETURN_T	Return Air Temperature	xxx.x	° F		Building Return Air Temp
PE_1	Power Exhaust 1 Relay	Off/On			N/A
PE_2	Power Exhaust 2 Relay	Off/On			N/A
IAQANCFG	IAQ Analog Input Config	0=No IAQ 1=DCV 2=Override IAQ 3=Ctrl Min Pos		0: no FIOP 1: FIOP	Tells if a sensor is installed for DCV or override
IAQANFAN	IAQ Analog Fan Config	0=Never 1=Occupied 2=Always		0	Tells if the ERV can run during unoccupied for high CO2
IAQINCFG	IAQ Switch Input Config	0=No IAQ 1=DCV N/O 2=DCV N/C 3=Override N/O 4=Override N/C		0	Tells if a switch is installed for DCV or override
IAQINFAN	IAQ Switch Fan Config	0=Never 1=Occupied 2=Always		0	Tells if the ERV can run during unoccupied for high CO2
DAQ_LOW	AQ Differential Low	0 to 5000		100	Sets indoor/outdoor PPM difference to start ventilating more
DAQ_HIGH	AQ Differential High	0 to 5000		700	Sets indoor/outdoor PPM at which max vent occurs
IAQOVPOS	IAQ Override Position	0 to 100	%	100	Sets OA fan speed during override
S_WHEEL	OAU Wheel Test	0 to100	%	0	Test wheel while in test mode
S_OAFAN	OAU OA Fan Speed Test	0 to100	%	0	Test intake fan(s) while in test mode
S_EXFAN	OAU PE Fan Speed Test	0 to100	%	0	Test exhaust fan(s) while in test mode
S_OAHEAT	OAU Tempering Heater Test	0 to 100	%	0	Test tempering heater while in test mode

Table 3 – Configurations - ERV Configurations Read

Value	Expanded Text	Range	Units	Default	Function
OAU_TYPE	Outdoor Air Unit Type	0=No OAU 1=ERV Module 2=Economizer* 3=Pwr Exhaust 4=OA Monitor 5=100% OA unit 6=EXv1 ERV		0: no FIOP 1: FIOP EXv2	Defines what kind of OAU is installed
OAFANCRV	Outside Air Fan Curve	0 to 999		1: 04 2: 05–06 3: 07 4: 08–12 5: 14 6: 17–20 7: 24–28	Determine what outside air fan curve to use
PEFANCRV	Exhaust Air Fan Curve	0 to 999		1: 04, 1ph, and econ* 2: 04, 3ph, and econ* 3: 04, 1ph, and no econ* 4: 04, 3ph, and no econ* 5: 05–06 1ph 6: 05–06 3ph 7: 07 8: 08–12 9: 14 10: 17–20 and econ* 11: 17–20 and no econ* 12: 24–28	Determine what exhaust air fan curve to use
UNOCCRUN	OAU Unoccupied Operation	No/Yes		NO	Tells OAU to run in unoccupied mode
FATALOAU	Shut Down on Fan Failure	No/Yes		YES	Tells OAU to shut off if one of it's fans fail
MODWHEEL	Modulating Wheel Install	No/Yes		NO	Determine if the OAU's wheel is a modulating one
MINOACFM	Minimum Outside Air CFM	0 to 32000	CFM	375: 04 800: 05–06 1000: 07 2500: 08–12 3000: 14 4000: 17–20 5000: 24–28	Sets Design OA CFM for ventilation
MINDCVSP	Min DCV Outside Air CFM	0 to 32000	CFM	100: 04 250: 05–06 600: 07 1000: 08–12 1500: 14–24 2000: 24–28	Sets absolute minimum OA CFM for ventilation
PEX_CTL	Power Exhaust Control	0=offset CFM 1=BP		0	Determine how to control the exhaust fans
EXOFFSET	Power Exhaust CFM Offset	–17000 to 17000	CFM	–200	Sets offset CFM setpoint of exhaust based on intake
OAU_BPSP	Building Pressure Setpnt	–0.25 to 0.25	inH ₂ O	0.05	Sets required building pressure
OATEMPER	Outside Air Tempering	Disable/Enable		Disable	Determine if there is tempering heater installed
OATMPLOC	OA Tempring Lockout Temp	0 to 80	°F	60	Sets the outside temp and below to allow tempering
OATMPSPT	OA Tempring SAT Setpoint	35 to 80	°F	55	Sets target Supply air temperature during tempering
OACFM_K	Outside Air CFM k Factor	0.8 to 1.2		1.0	Sets outside air curve correction factor
EXCFM_K	Exhaust Air CFM k Factor	0.8 to 1.2		1.0	Sets exhaust air curve correction factor
EFB_ENBL	ERV Fan Boost Enable	No/Yes		NO	Tells RTU to adjust fan speed for low outside air CFM

* Requires an Economize which is not available for Target EnergyX units at this time.

Table 4 – Status Points - ERV Writes these Values

Value	Expanded Text	Range	Units	Function
OAU_RUN	OAU System Run State	1=AUTO 2=OFF 3=TEST		High level ERV state
OAU_MODE	OAU Operating Mode	0=Off 1=ERV (DCV) 2=Free Cooling* 3=OA Tempering 4=Defrost 5=Test 6=Ext. Mode 1 7=Ext. Mode 2 8=Ext. Mode 3		ERV's current operating mode
OAU_VER	OA Unit Software Version	0 to 9999		Active EXCB software version
ACTOACFM	Actual Outside Air CFM	0 to 32000	CFM	Real Time CFM being brought in
ACTEXCFM	Actual Exhaust Air CFM	0 to 32000	CFM	Real Time CFM being exhausted
CMDOACFM	Command Outside Air CFM	0 to 32000	CFM	Commanded CFM to bring in
CMDEXCFM	Command Exhaust Air CFM	0 to 32000	CFM	Commanded CFM to exhaust
OAU_LAT	OAU Leaving Air Temp	xxx.x	° F	Air temperature leaving the ERV (RTU intake)
OAU_EXAT	OAU Exhaust Air Temp	xxx.x	° F	Air Temperature leaving the ERV (exhaust)
OAU_BP	Building Pressure	-0.25 to 0.25	inH ₂ O	Current building pressure
OAUWHEEL	OAU Wheel Speed	0 to100	%	Current ERV wheel speed
OAFANSPD	OAU OA Fan Speed	0 to100	%	Current ERV's intake fan speed
OAUPESPD	OAU Exhaust Fan Speed	0 to100	%	Current ERV's exhaust fan speed
OAHEATER	OAU Tempering Heater	0 to 100	%	ERV's SCR heater commanded capacity
OAUALRM1	OAU Motor Failure Alarm	Off/On		ERV's motor failure alarm status
OAUALRM3	OA Low CFM Alarm	Off/On		ERV's low CFM alarm status
OAUALRM4	OAU Alarm	Off/On		ERV's General Alarm status

* Requires an Economizer which is not available for Target EnergyX units at this time.

EnergyX

12.5 Ton Modulating ERV

The modulating ERV is an intelligent ERV with variable speed fan motors. The ERV can provide a variety of volumes of outside air and offset it with different exhaust speeds. CO₂ sensors can also be tied into it for Demand

control ventilation (DCV) operation. The modulating ERV will operate based on occupancy and the rooftop's operating mode, the following sections explain operation in detail. Refer to Fig. 6 for the overview flow diagram of a modulating ERV operation.

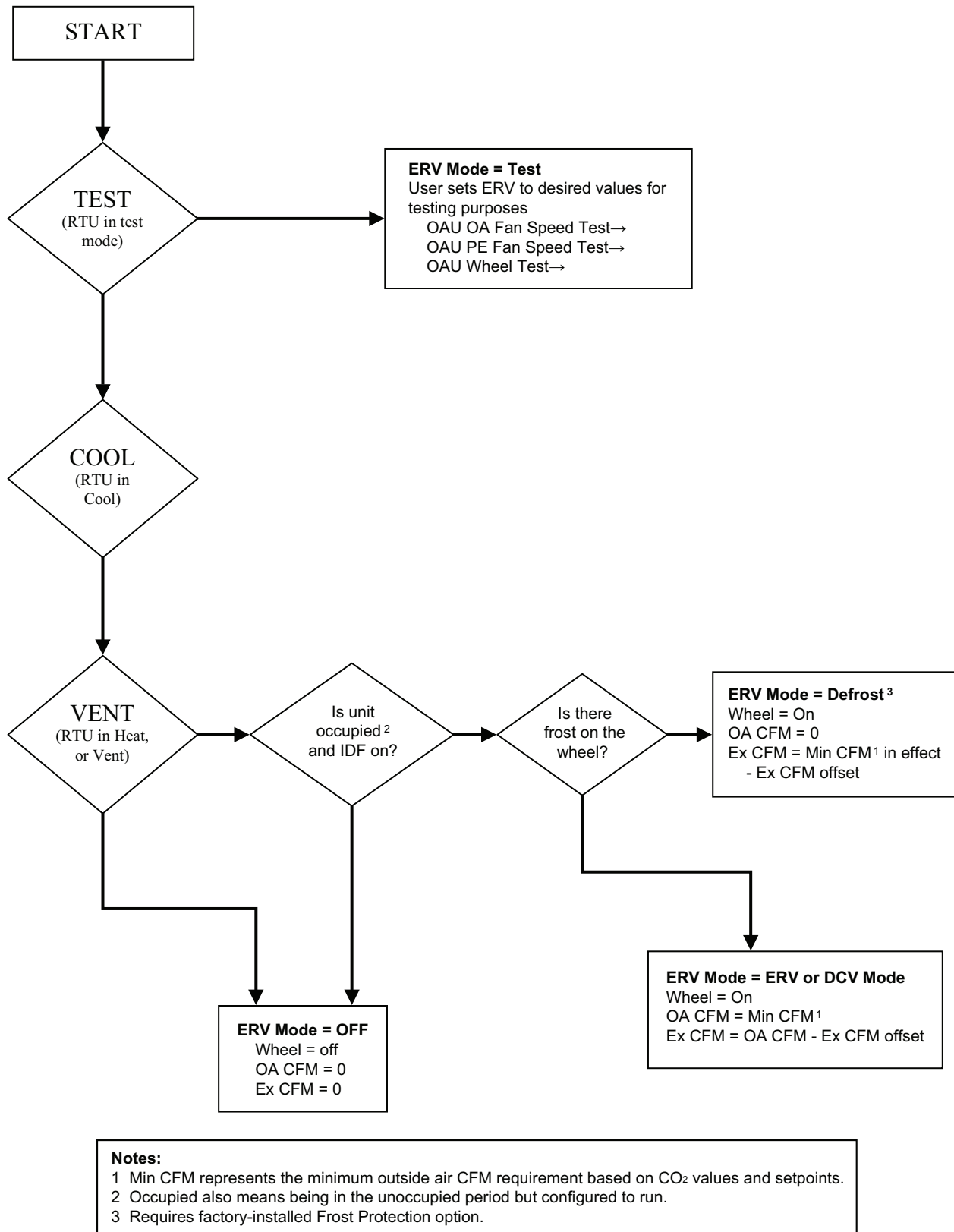

EnergyX

Fig. 6 - Modulating ERV Control & Operation Flow Chart

C13025

Occupancy

The ERV will not be allowed to run unless it is determined to be occupied. The ERV monitors the rooftop's occupancy point to determine when it is occupied. The ERV watches the rooftop's indoor fan state point to know when its indoor fan has started. When the rooftop is occupied and its indoor fan is on, the ERV is considered to be occupied and allowed to run.

The ERV can also operate during the rooftop's unoccupied period. If the ERV is configured for unoccupied operation then it will ignore the building occupancy of I/O Flex 6126 and allow occupancy any time the rooftop fan is on.

Modes of Operation

The ERV has 3 basic functions: Auto, Off, or Test. These are defined as System run states and displayed in the OAU run status menu. The ERV will always operate in one of the following operating modes depending upon the mode and outside conditions: Off, ERV (DCV) Free Cooling, OA Tempering, Defrost, or Test. The ERV monitors to determine the rooftops operating mode. The values tell the ERV what the rooftop operating mode is in a numeric form. These modes are described below.

Off Mode —

The ERV will be set to the Off mode whenever the rooftop indoor fan is turned off, ERV is unoccupied or if communication fails. During Off Mode the wheel, outside air fans(s), and exhaust fan(s) will be off.

Test Mode —

If at any time during operation, the rooftop is put in Service Test mode the ERV will be set to Test Mode. Refer to Start-Up section for Test mode operation.

Defrost Mode —

Defrost Mode is only available when the optional Frost Protection is factory installed in the ERV. The ERV will be set to defrost mode any time the ERV wheel is running and frost is detected on the wheel. Defrost Mode runs for at least 2 minutes but continues to run until the frost is removed. The frost protection device senses a pressure differential across the wheel and trips when that differential is greater than the setpoint (default 2.0 in wc). For information on the frost protection device, refer to the Major Component section.

When in Defrost Mode the outside air fan(s) will ramp down to 0% speed (shut-off). The exhaust fan(s) will run at a speed equal to the required offset CFM. Refer to Exhaust Control for details on determining offset CFM.

ERV (DCV) Mode —

General ERV Mode – ERV Mode is the basic operating mode of the ERV. With no options installed on the ERV this will be the only operating mode besides off and test. ERV Mode will be active when the rooftop mode is Heating, Cooling, Fan Only, or Dehumidification and the ERV is occupied.

DCV ERV Mode will be active when the rooftop mode is Heating, Cooling, Fan Only, or Dehumidification and the ERV is occupied.

When in DCV ERV mode wheel will be rotating. The outside air fan(s) will run at a speed that produces a CFM equal to the minimum outside air CFM determined by Demand Control Ventilation (DCV). The exhaust fan will run at a speed equal to the required offset CFM. Refer to Exhaust Control for details on determining offset CFM.

Switch Demand Control Ventilation (DCV) uses the indoor air quality levels (High/Low) to determine how much outside air is required for ventilation. The ERV monitors the IAQ switch reading from the rooftop's installed CO₂ switch. The minimum outside air CFM will be equal to one of the following: Min DCV outside air CFM setpoint, or the minimum outside air CFM setpoint. If the CO₂ switch reads low the outside air CFM requirement will be DCV.M. If the switch reads high the outside air CFM requirement will be OA.MN. The outside air fan(s) will ramp its speed % up or down to produce the required CFM.

Exhaust Control

When the Power Exhaust control is set of Offset CFM the ERV exhaust fan(s) operate to offset the outside air being introduced to the building. The required exhaust offset CFM is determined based on the exhaust offset setpoint. The exhaust offset setpoint can be set as a negative or positive number to accommodate a requirement of positive or negative building pressure. A positive setpoint will produce a negative building pressure. A negative setpoint will produce a positive building pressure.

The ERV will determine the required amount of outside air CFM based on setpoints and current mode of operation. The commanded exhaust air CFM is then calculated by the sum of the actual outside air CFM and the exhaust air offset setpoint. During defrost mode the exhaust will run the same as if the outside air fan were still running.

TROUBLESHOOTING

EnergyX units are a combination of the base rooftop unit and an integrated ERV. The ERV requires communication from the rooftop for operation. This section covers ERV troubleshooting only. For rooftop troubleshooting refer to the base unit's Service manual.

Complete ERV Stoppage

There are several conditions that can cause the ERV to shutdown or appear to be shutdown:

- General power failure.
- Transformer's circuit breaker tripped.
- ERV main power fuses blown.
- Communication failures.
- Active alarm on the base rooftop unit or the ERV preventing operation. Review alarms.

- Programmed occupancy schedule. Rooftop Unoccupied
- Rooftop indoor fan is off.
- The airflow sensor tubing connected to the incorrect high/low sensor ports in the outside air.

Wheel Status (Option) —

NOTE: Wheel Status requires installation of the optional wheel motion sensor.

This alarm will occur when the ERV wheel is turned on and the wheel proxy sensor does not detect wheel motion within the set time. It will open its contact which energizes the normally closed rotation monitor relay. This alarm will automatically reset when motion is detected. Possible causes of this alarm are: the wheel belt breaking or slipping, wheel motor failure, proxy sensor failure or incorrect setting, or wiring error.

On-board Pressure Transducers

The EXCB uses on-board pressure transducers to measure the air pressure of the incoming outside air and the building exhaust air. The CFM values are then calculated based on these readings and the fan speed. There is a pressure transducer for the outside air and one for the exhaust air. These are screwed into the EXCB board to J24 and J25 respectively. They have three pins: IN, GND, and OUT. The IN pin is 5vdc input power and GND is the common or ground pin. The OUT pin will be 0.26 to 4.5vdc based on the pressure reading. There are two different transducers used, two inch of water column (inWC) and 5 inWC. Table 5 shows the voltage/pressure characteristics of each.

Table 5 – Transducer/Voltage vs. Pressure

Voltage (vDC)	Pressure (inWC)	
	2" transducer	5" transducer
<= -0.26	0	0
0.5	0.12	0.28
1	0.34	0.87
1.5	0.53	1.46
2	0.82	2.05
2.5	1.06	2.64
3	1.30	3.23
3.5	1.52	3.82
4	1.76	4.41
4.5	2.00	5.00

EnergyX Control Board LEDs

The EnergyX Control Board (EXCB) has five green LEDs and one red LED. The red LED is for power indication and the green LEDs are status indicators (see Table 6 for details).

MAJOR SYSTEM COMPONENTS

An EnergyX unit has a factory installed energy recovery (ERV) device on a 48/50HC rooftop unit. The EnergyX energy recovery unit is integrated into the base rooftop unit construction and is factory wired. The energy recovery unit contains a control box, supply fan, exhaust fan(s), and an enthalpy wheel assembly. All control operations of the ERV are based on the rooftop units operation through communication with I/O Flex 6126. See Fig. 7 and 8 for ERV wiring schematic and component arrangement.

Table 6 – EXCB LED Indicators

LED	COLOR	DESCRIPTION	STATUS IF LIGHT IS LIT
D9	Red	24vAC board power	Board has power
D2	Green	Run light Flashing	ERV is Running
D12	Green	ERV Wheel Status Alarm ¹	ERV Wheel not rotating when it should be
D14	Green	ERV Wheel Frost Protection ²	ERV detects frost on the wheel and running in Frost Mode
D16	Green	ERV Dirty Filter Alarm ³	Dirty Filter
D18	Green	ERV Blower Status Alarm	Fan Failure

1 Requires installation of optional Wheel Motion sensor
 2 Requires installation of optional Frost sensor
 3 Requires installation of optional Filter sensor

TARGET ENERGY X

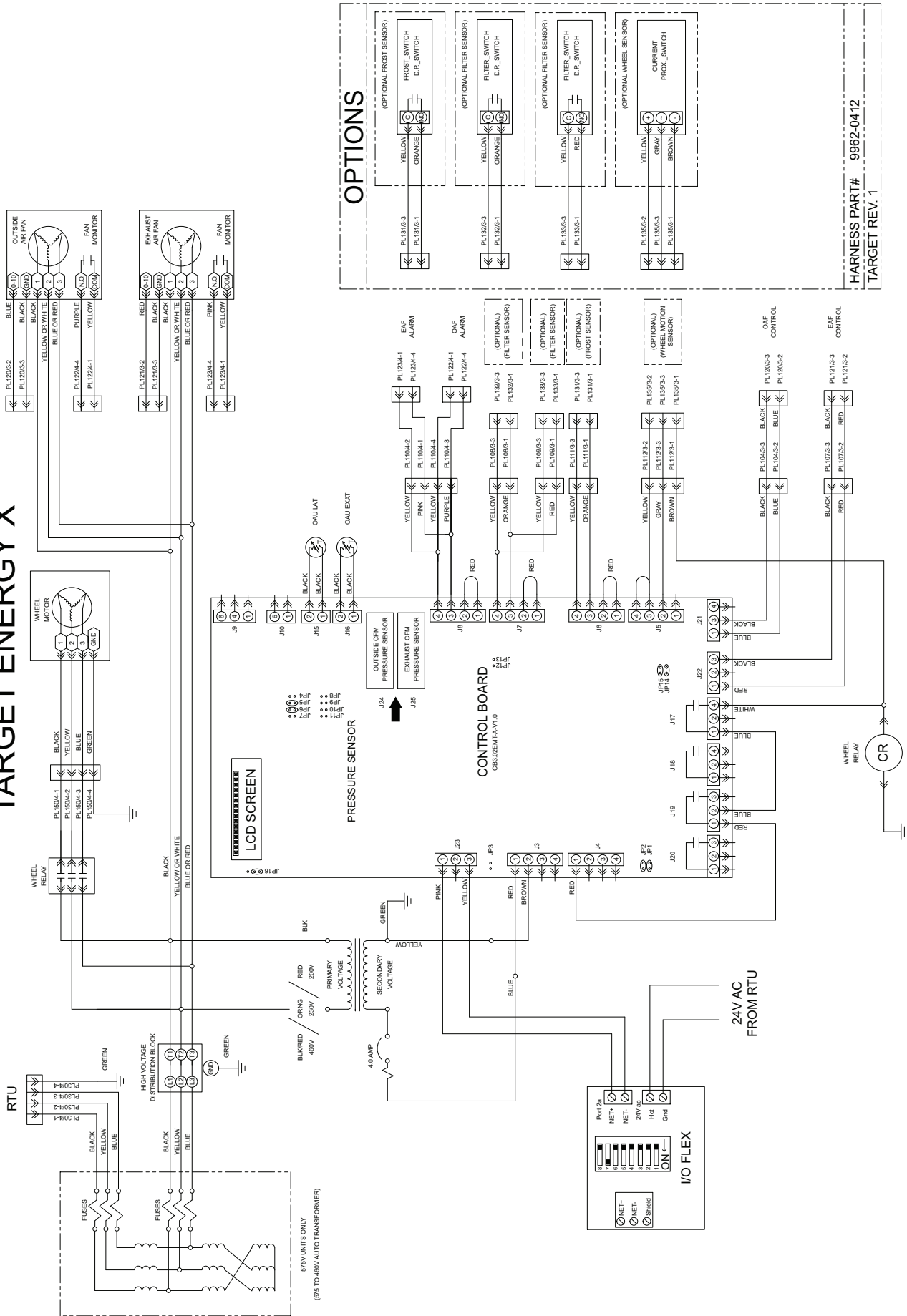

OPTIONS

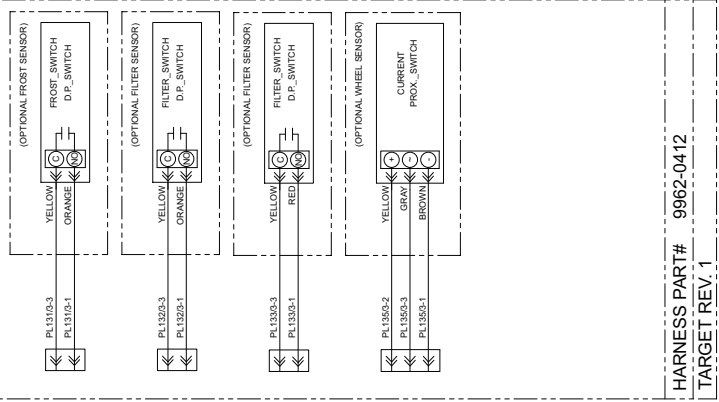

HARNESS PART# 9962-0412
TARGET REV. 1

Fig. 7 - Modulating ERV Wiring Schematic

UPPER CONTROL BOX

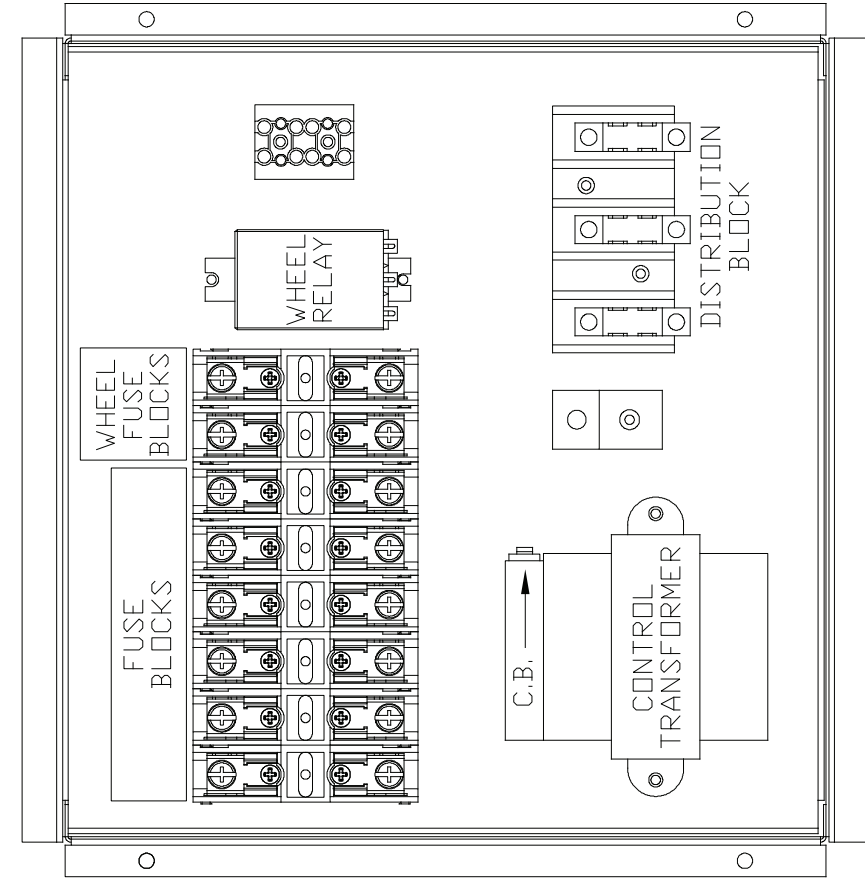

LOWER CONTROL BOX

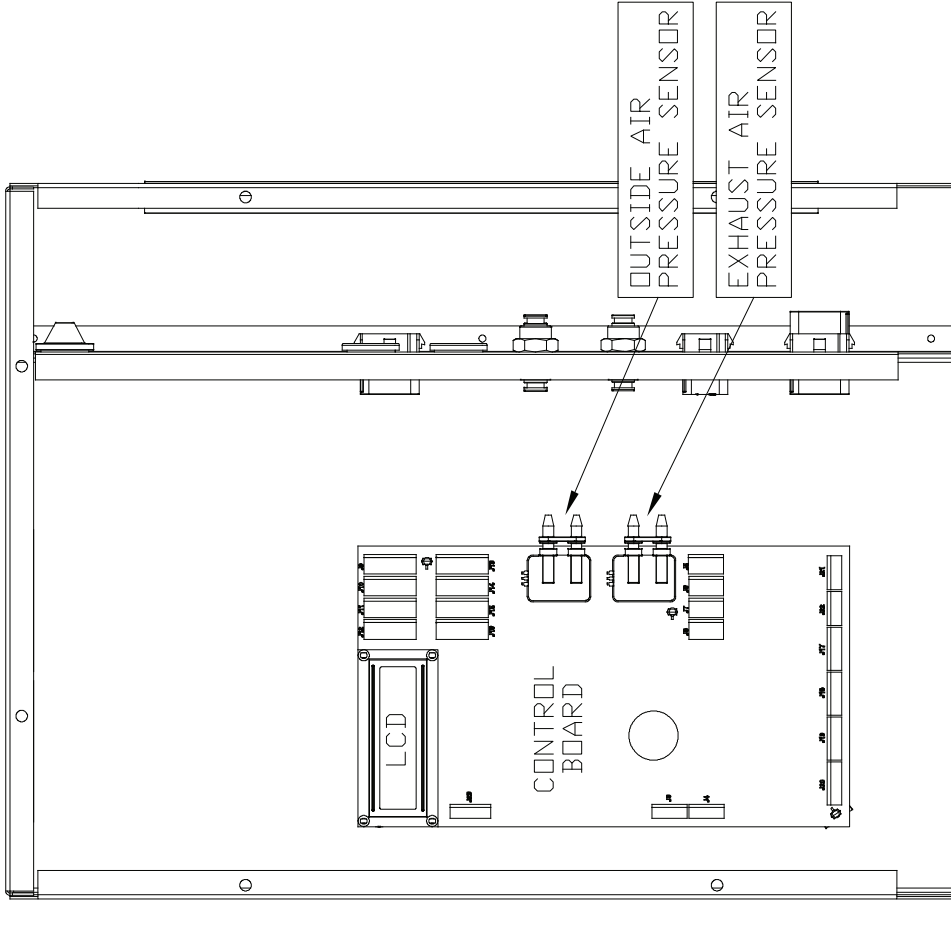

AIR FLOW TUBING	
GREEN	OUTSIDE AIR HIGH
YELLOW	OUTSIDE AIR LOW
RED	EXHAUST AIR HIGH
CLEAR	EXHAUST AIR LOW

Fig. 8 - EnergyX Component Layout

C12776



EnergyX Control Board (EXCB)

See Fig. 9 and Table 7.

The EXCB board is the muscle of the ERV control system. The EXCB continuously monitors input/output channel information received from its inputs. The EXCB receives

inputs from transducers and discrete inputs. See Options and Accessories section. The EXCB has relay analog outputs, and is equipped with a LCD screen. The EXCB has a reset button that is used to force all the outputs and reset communication.

NOTE: There are hardware jumpers set throughout the. Do not change these jumpers.

EnergyX

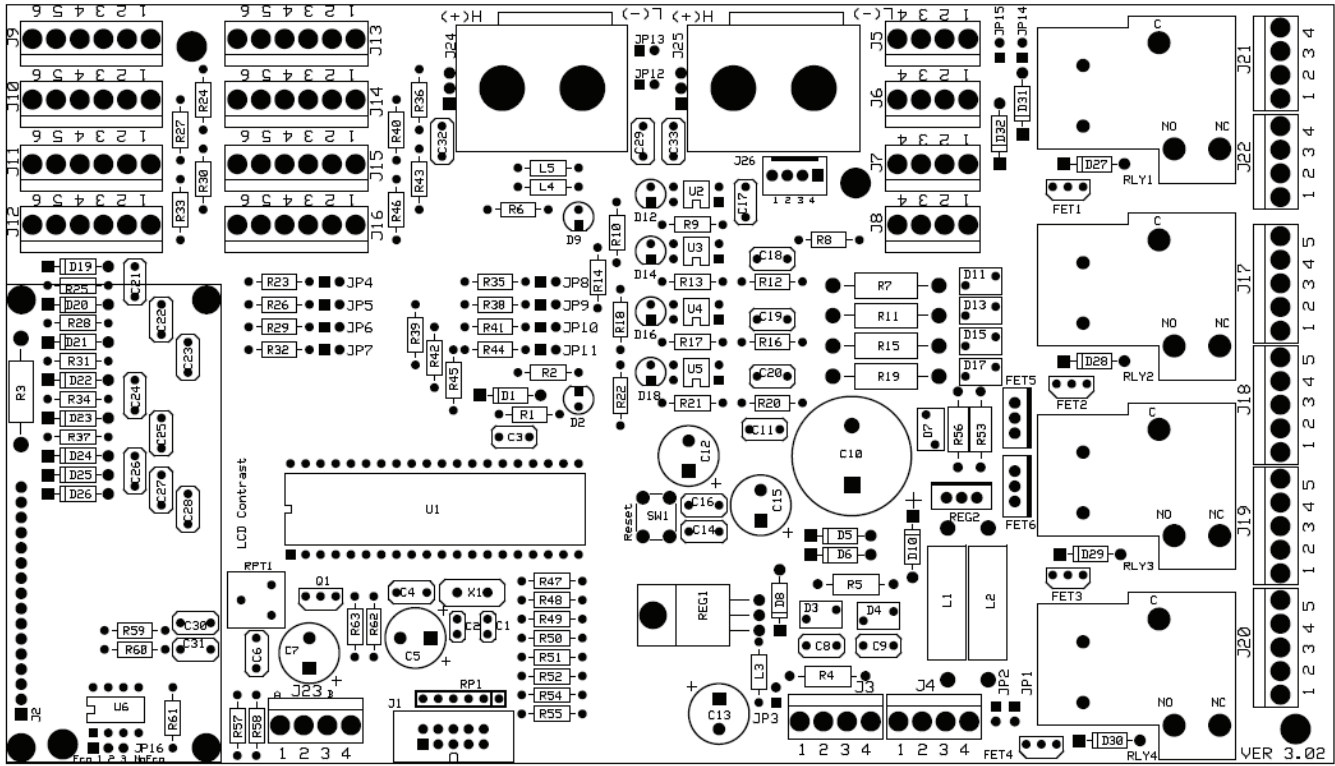

Fig. 9 - EnergyX Control Board (EXCB)

C11467

Table 7 – EXCB Input/Output Connections

POINT DESCRIPTION	SENSOR LOCATION	Input/Output	TYPE OF Input/Output	CONNECTION PIN NUMBER
Download	N/A	Both	Communication	J1
Power from TRANS	Control box	Input	24VAC	J3, 1–2
Power to Relays	Low voltage control box	Output	24VAC	J4, 1
Wheel Rotation Sensor	Attached to scoop	Input	Switch	J5, 2–4
Frost Switch	Attached to scoop	Input	Switch	J6, 3–4
Leaving Air Temp	Scoop section	Input	10K	J15, 1–2
Exhaust Air Temp	Exhaust air section	Input	10K	J16, 1–2
Wheel Relay	High voltage control box	Output	Relay	J17, 4
OA fan speed signal	N/A	Output	2–10vdc	J21, 1–3
EX fan speed signal	N/A	Output	2–10vdc	J22, 1–3
Outside Air pressure Transducer	Low voltage control box	Input	Digital 0–5vdc	J24
Exhaust Air pressure Transducer	Low voltage control box	Input	Digital 0–5vdc	J25
Building Pressure Sensor	Low voltage control box	Input	4–20mA	J10, 1–6

Enthalpy Wheel

The enthalpy wheel is the “heat exchangers” of the ERV. It consists of several wheel segments aligned in a cassette assembly. These are not “filters” but made of a desiccant material. The wheel is rotated by a motor and belt, no adjustments required. When the wheel rotates it uses the building exhaust air to pre-conditions the outside air as it passes through the wheel.

Modulating Fan

The modulating ERV is equipped with direct drive variable speed plenum fans for outside air intake and exhaust air. The motors have built in VFDs that accept a 2-10vdc signal from the EXCB. This 2-10vdc signal is used by the VFD to determine the speed to run the motor at (0-100%).

Each motor is capable of diagnosing problems within the motor to provide fan status. The fan status switches are built into each motor and provide a feedback to the EXCB if a problem is detected. The feedback signal is a discrete input that is normally open, when closed the EXCB will initiate the motor status alarm.

Options and Accessories

The modulating ERV has several optional factory installed options and field installed accessories: Frost Protection, Wheel Motor Status, Filter Maintenance, horizontal adaptor curb, building pressure sensor, and Outside Air Tempering Kit. Refer to Table 7 for where these options wire into the EXCB.

Frost Protection (factory-installed option only)

Frost protection is a factory installed pressure sensor device which senses a differential pressure across the wheel. This occurs if frost builds up on the wheel. The sensor closes its contact when the pressure differential is greater than the setpoint. When the EXCB reads the contact closer it will activate defrost mode. The setpoint is a dial on the sensor, is adjustable from 0.2 to 2.0 inWC, and is factory preset to 2.0 inWC. Changing this setting may cause false signal causing defrost mode when not needed.

Wheel Motor Status (option)

The wheel motor status accessory can be installed in the field and consists of a wheel motion proxy sensor and a relay. The wheel motion sensor is aimed at the wheel to detect rotation. If the wheel does not rotate at the appropriate speed the sensor will open causing the rotation monitor relay to close a contact to initiate the wheel status alarm. The motion sensor is factory set at the highest speed (clockwise until stop) and should not be changed. Refer to the troubleshooting section for details on the alarms.

SERVICE & MAINTENANCE

Refer to base unit's Service manual for base unit service and maintenance. This section contains service and maintenance for just the ERV unit.

Cleaning

Wheel and Segment Cleaning

Wheel cleaning periodicity is application dependent. Field experience shows that offices, schools and other "clean" environments will often go 10 years before any build up of dust and dirt is noticed. Other applications such as restaurants, casinos and factory environments may experience fairly rapid build-up of contaminants and may require multiple cleanings per year to maintain airflow and recovery efficiencies.

All air-to-air energy recovery devices will become dirty over time, even with well-maintained filtration. Proper filtration usage and changes will improve the life of the wheel transfer segments. Once the wheel is exposed to oils, tars or greases in either the supply or exhaust air streams, these pollutants deposit on the rotary surface which then become "sticky" and begin to attract and hold the dust particles that previously passed thru the wheel. Over time this particle build up can lead to blocked airflow passages, loss of recovery, excessive pressure drop through the wheel and loss of energy savings.

1. Follow steps for wheel and segment removal to remove the affected energy transfer matrix segments.
2. Gently brush the wheel face to remove loose accumulated dirt.
3. Wash the segments with a non-acid based (evaporator) coil cleaner or alkaline detergent solution. Non-acid based coil cleaner such as KMP Acti-Clean AK-1 concentrate in a 5% solution has been demonstrated to provide excellent results. **DO NOT** use acid based cleaners, aromatic solvents, temperatures in excess of 170°F or steam! Damage to the wheel will result.
4. Soak the wheel and/or segments in the cleaning solution until all grease and tar deposits are loosened. An overnight soak may be required to adequately loosen heavy deposits of tar and oil based contaminants.
5. Internal heat exchange surfaces may be examined by separating the polymer strips by hand. (Note: some staining of the desiccant may remain and is not harmful to performance.)
6. After soaking, rinse the dirty solution from the wheel segments until the water runs clear.
7. Allow excess water to drain prior to replacing segments in the wheel. A small amount of water remaining in the wheel will be dried out by the airflow.

Filters

Clean or replace at start of each heating and cooling seasons, or more often if operating conditions require

(based on filter manufacture recommendation or filter status alarm indication). Refer to Table 1 for type and size of filters.

Outdoor-Air Inlet Screens

Clean screens with steam or hot water and a mild detergent at the beginning of each heating and cooling season. Do not use throwaway filters in place of screens.

Lubrication

All component bearings are sealed and do not require lubrication.

Wheel Drive Adjustment

The wheel motor and drives do not require adjustment. The wheel drive pulley is secured to the drive motor shaft by a set screw. The set screw is secured with removable locktite to prevent loosening. Annually confirm set screw is secure. The wheel drive belt is a urethane stretch belt designed to provide constant tension throughout the life of the belt. Inspect the drive belt annually for proper tracking and tension. A properly tensioned belt will turn the wheel immediately after power is applied with no visible slippage during start-up.

Wheel Air Seal Adjustment

Diameter seals are provided on each wheel cassette to minimize transfer of air between the counter flowing airstreams. Follow below instructions if adjustment is needed.

1. Loosen diameter seal adjusting screws and back seals away from the wheel surface. See Fig. 10.

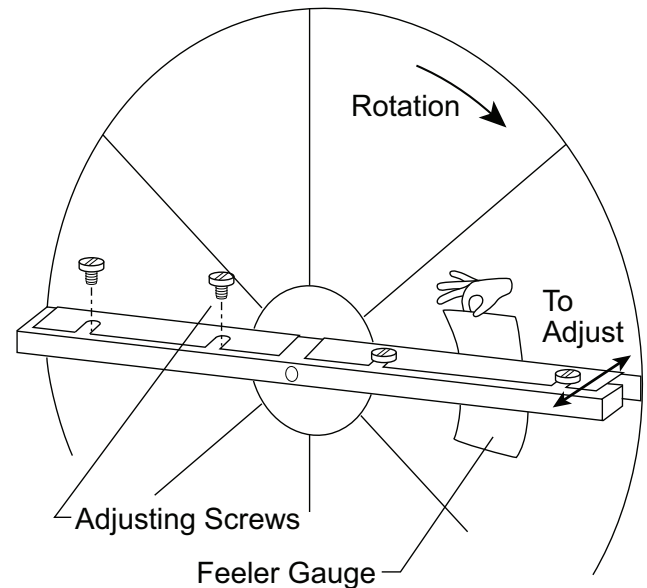

C11469

Fig. 10 - Diameter Seal Adjustment

2. Rotate the wheel clockwise until two opposing spokes are hidden behind the bearing support beam.
3. Using a folded piece of paper as a feeler gauge, position the paper between the seal and wheel surface.

- Adjust the seal towards wheel surface until a slight friction on the feeder gauge (paper) is detected while moving the gauge along the length of the spoke.
- Re-tighten adjustment screws and re-check clearance with the feeder gauge.

Wheel and Segment Removal / Installation

The wheel and segments represent a substantial portion of the value of the cassette therefore must be handled with care and never be dropped. Use a suitable crate or harness to lift wheel and segments to a roof surface, never use the shipping cartons for this purpose. Wheel and segments may require “slight” persuasion during installation and removal but never forced or impacted with a hammer or similar tool. The wheel assembly can be removed and installed or the wheel or segments can be removed from the assembly.

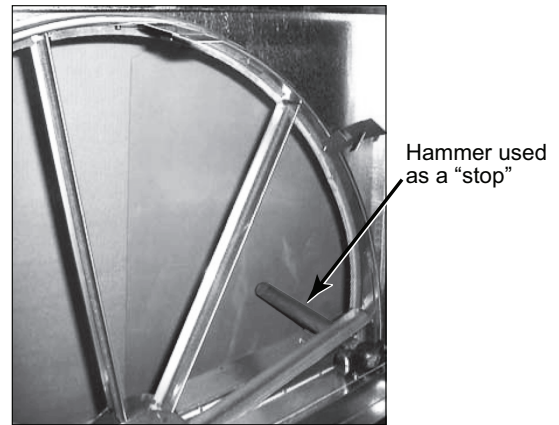

Fig. 11 - Wheel Stop

C11470

⚠ CAUTION

UNIT DAMAGE HAZARD

Failure to follow this caution may result in equipment damage.

The weight of the wheel assembly must be supported when the assembly is extended from the unit chassis to avoid damage to wheel or unit.

The ERV wheel on 12.5 ton units is a segmented wheel assembly. To remove or install the whole assembly, simply slide in or out the assembly noting the motor power plug.



Fig. 12 - Matrix Retaining Straps

C13083

Wheel Segment Removal / Installation

- Turn off, lockout and tag-out electrical power to unit.
- Open access door to the EnergyX module on back side of the unit.
- Slide the entire wheel assembly out until the necessary segment(s) of the wheel can be accessed. Support the weight of the wheel assembly as necessary to avoid damage to wheel or unit.

⚠ CAUTION

PERSONAL INJURY HAZARD

Failure to follow this caution may result in personal injury.

Weight of the installed segment will cause the wheel to accelerate in rotation as segments are removed. Failure to maintain control of the wheel rotation while installing all segments could cause severe injury to fingers or hand caught between revolving spokes and the bearing support beam. The handle of a tool such as a hammer, should be inserted through spokes and above or below bearing support beams to limit rotation of unbalanced wheel. See Fig. 11.

- Position one segment opening at the top of the cassette.
- Pry out and open the segment retaining straps on both sides of the selected segment opening. See Fig. 12.

- Gently lift segment outward.
- Close and lock the matrix retaining straps and rotate wheel 180° to remove next segment. Follow this pattern to remove all segments and keep wheel balanced.
- To install the wheel segments, hold the segment as vertically as possible and centered between spokes, insert nose of segment downward between the hub plates. See Fig. 13.

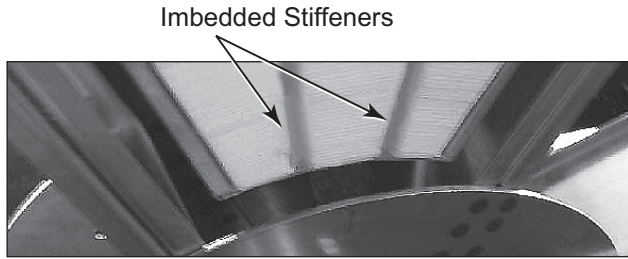

Fig. 13 - Segment Removal

C11472

EnergyX

NOTE: The face of the segment, with the imbedded stiffener (vertical support between nose and rim end of segment) must face the motor side of the cassette. See Fig. 14.



C11473

Fig. 14 - Imbedded Wheel Stiffeners
(shown from motor side of wheel assembly)

9. Ease the segment downward until its outer rim clears the inside of the wheel rim. Press the segment inward against the spoke flanges.
10. Reinstall the segment retaining straps to the position shown in Fig. 12. Make certain the retaining bracket is fully engaged under the catch.
11. Slowly rotate, by hand, the first installed segment to the bottom of the cassette, and then install the second segment opposite the first. Repeat this sequence with the two installed segments rotated to the horizontal position to balance the weight of installed segments.
12. Continue this sequence with the remaining segments as necessary.
13. When complete, close access door and remove lock-out and tag-out to apply power to unit.

Whole Wheel Removal/Installation **(30" wheel)**

These wheels include the shaft and are secured to two wheel support beams by two flange bearings with locking collars.

Follow the steps below for removal and reverse for installation. See Fig. 15.

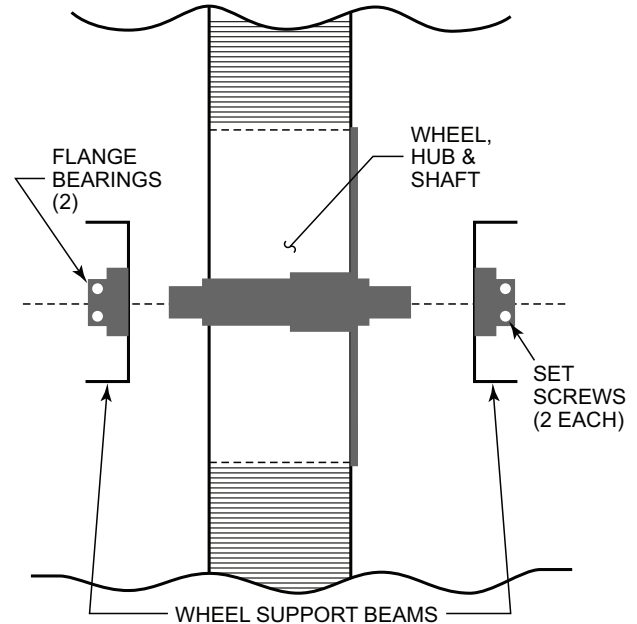

C11474

Fig. 15 - 30" Wheel Mount

1. Loosen the two set screws on each to the two wheel bearings.
2. Remove belt from pulley and position temporarily around wheel rim.
3. Remove pulley side wheel support beam with bearing, by removing four support beam screws.
4. Pull the wheel with the shaft straight out of the motor side wheel support beam and bearing. Handle wheel with care.
5. When replacing wheel be certain to tighten four bearing set screws. Premature bearing failure can occur if not set tightly.

Outside Air and Exhaust Air Hood Removal

Outside Air Hood Removal

1. Turn off, lockout and tag-out electrical power to unit.
2. Remove the hood by removing the seal-tek screws along the perimeter of the hood. See Fig. 16.

NOTE: Even after all screws have been removed from entire perimeter of hood, it will still be difficult to remove

due to the gasket applied from original installation. Take care not to damage the gasket. If damage occurs use equivalent gasket to replace before reattaching the hood.

3. Disconnect the green (HIGH) and yellow (LOW) tubes attached to the quick connects located inside the ERV. Do NOT damage the tubes.

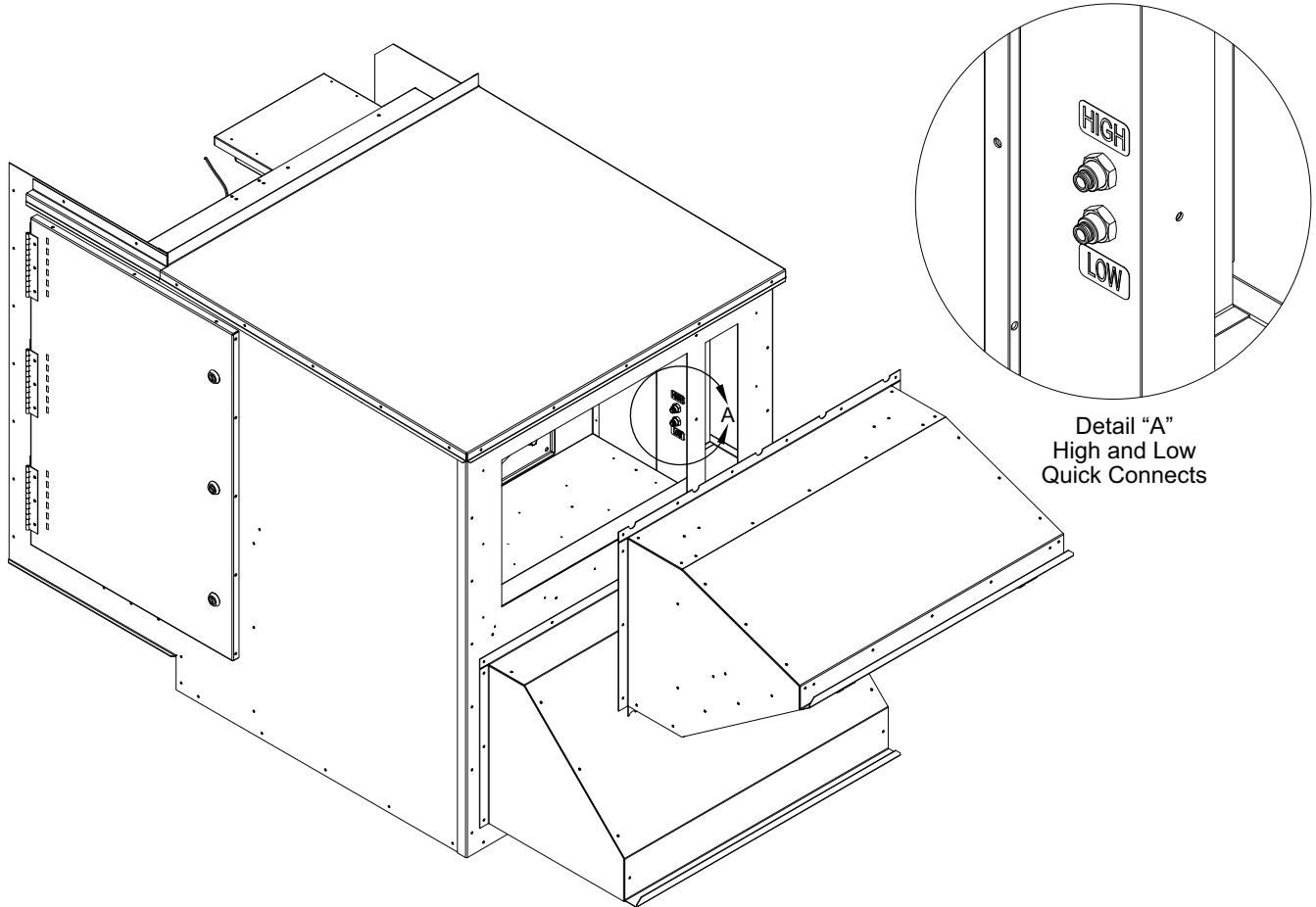

EnergyX

Fig. 16 - Outside Air Hood Removal

C13026

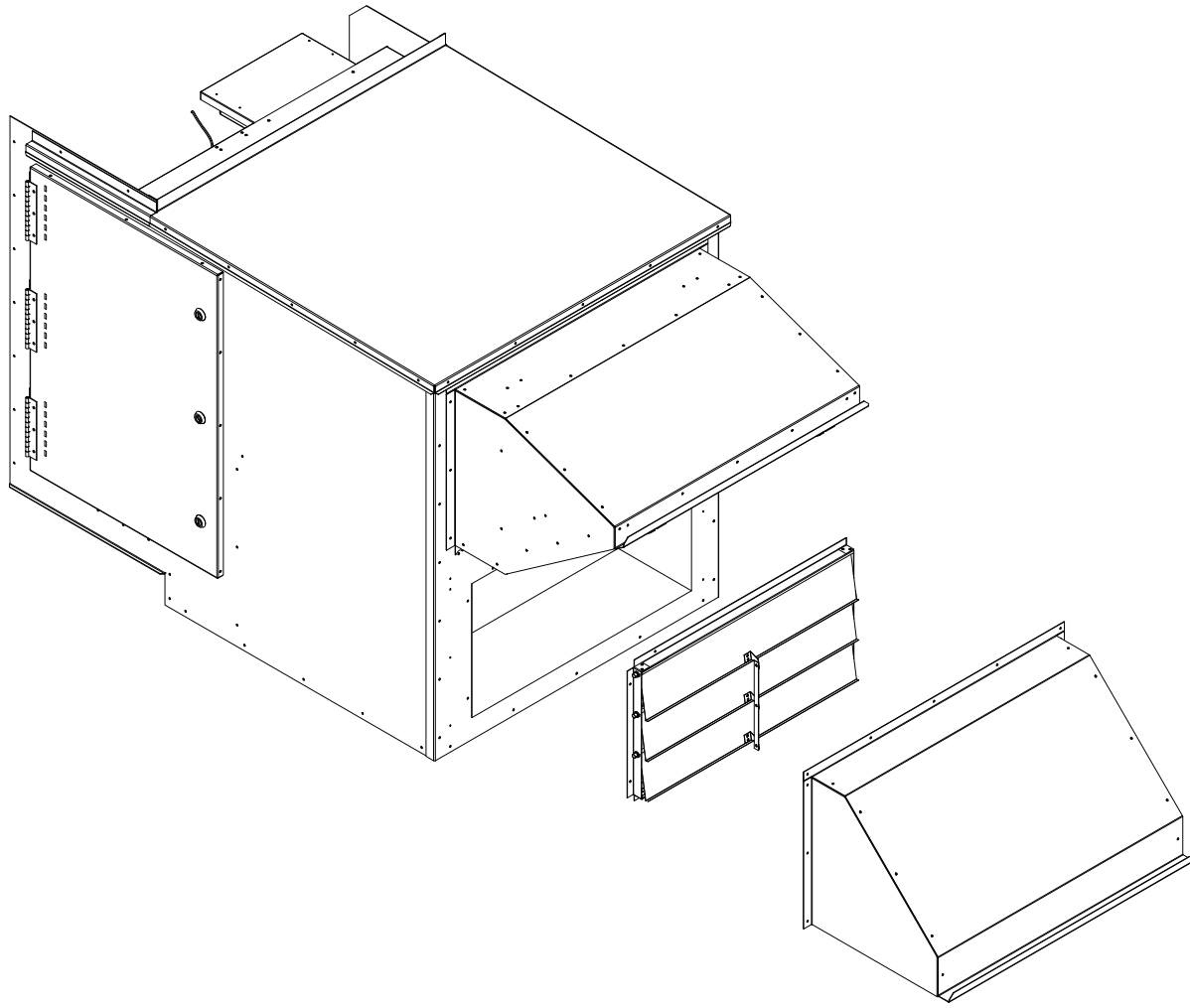

Fig. 17 - Exhaust Air Hood Removal

C13027

Exhaust Air Hood Removal

1. Turn off, lockout and tag-out electrical power to unit.
2. Remove the hood by removing the seal-tek screws along the perimeter of the hood.

NOTE: Even after all screws have been removed from entire perimeter of hood, it will still be difficult to remove due to the gasket applied from original installation. Take care not to damage the gasket. If damage occurs use equivalent gasket to replace before reattaching the hood.

Outside Air and Exhaust Fan Replacement

Outside Air Fan Removal

1. Turn off, lockout and tag-out electrical power to unit.
2. Remove outside air hood (see procedure on page 23).
3. Disconnect the connector PL121, PL123 and the power wires for the exhaust fan motor from the wiring harness inside the air chamber for the EnergyX.

4. Remove the fasteners at each corner of the outside air fan that secure the outside air fan front panel to the dividing wall by access through the hood opening of the ERV. See Fig. 18.

NOTE: See instructions for removing the wheel and supply filters if more room is needed to access the outside air fan through the door for better maneuverability.

5. Remove the four bolts holding the front fan panel onto the rest of the outside air fan assembly. Completely remove this panel from the EVR.

NOTE: Tilt the fan assembly front panel to fit it through the hood opening.

6. Pull the outside air fan out through the hood opening. See Fig. 19.

NOTE: Tilt the fan assembly to fit its back panel through the opening in the dividing wall.

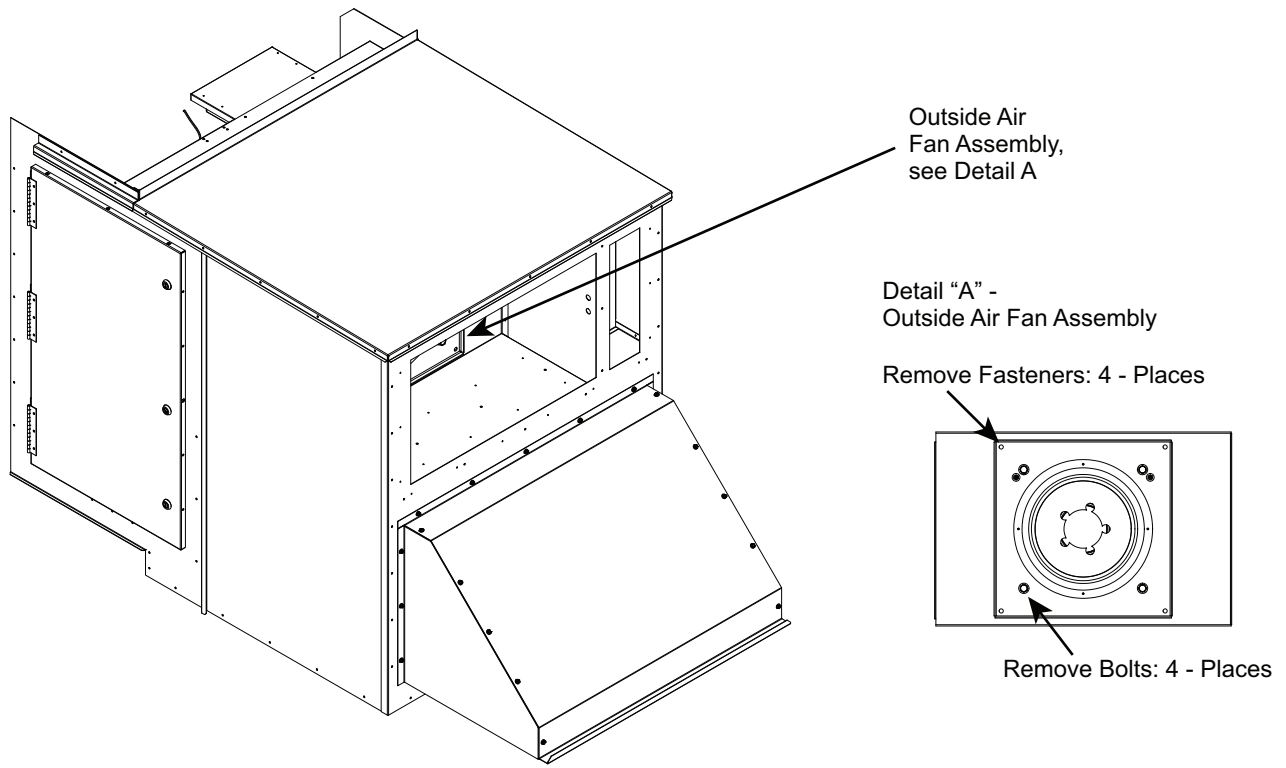

Fig. 18 - Remove Fasteners from Corners of Outside Air Fan Assemble

C13028

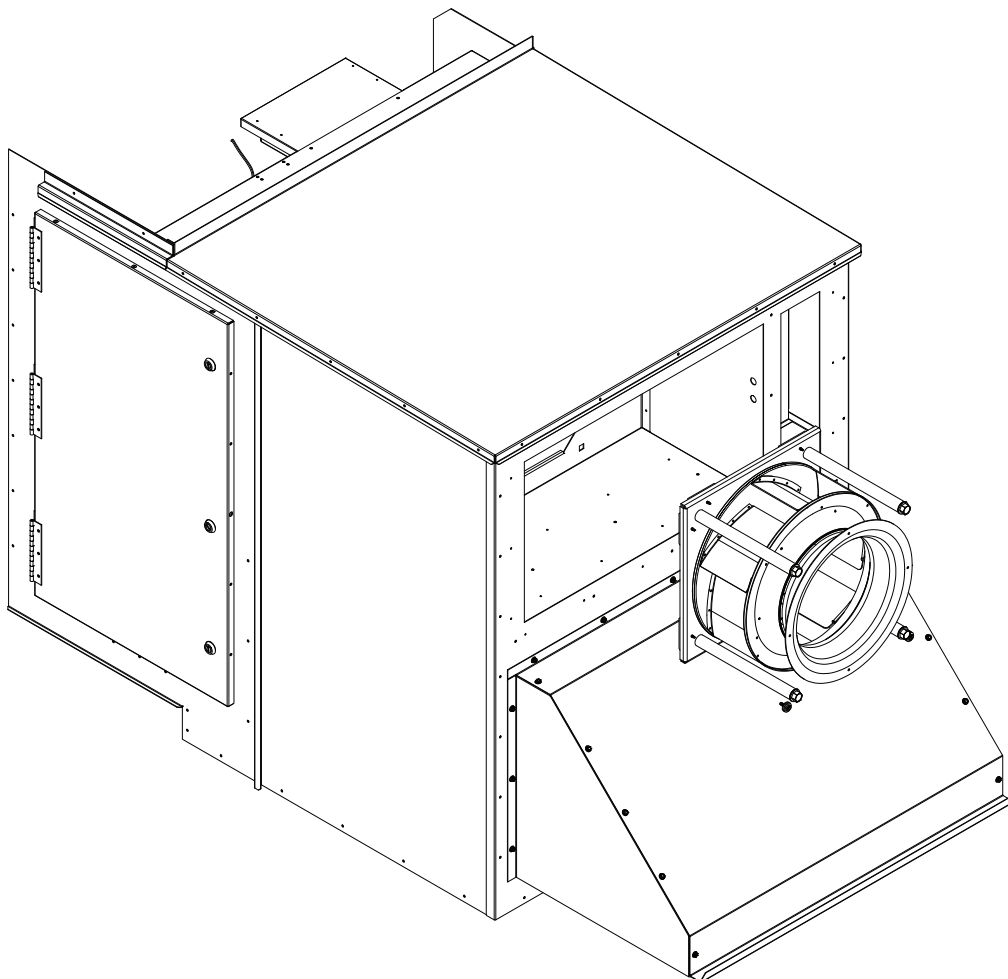

Fig. 19 - Outside Air Fan Removal

C13029

Exhaust Fan Removal

1. Turn off, lockout and tag-out electrical power to unit.
2. Remove the exhaust air hood (see procedure on page 23).
3. Open the door to the EnergyX unit in order to gain access to the exhaust fan front panel.

NOTE: See instructions for removing the wheel and exhaust filters if more room is needed to access the exhaust fan front panel.

4. Remove the fasteners around the perimeter of the exhaust fan that secure the exhaust fan front panel to

the dividing wall by access through the door of the unit. See Fig. 20.

5. Disconnect connectors PL120 and PL122 as well as the power wires for the exhaust fan motor from the wiring harness inside the air chamber of the EnergyX unit.

NOTE: Tilt the fan assembly front panel to fit it through the hood opening.

6. Pull the exhaust air fan out through the hood opening. See Fig. 20.

NOTE: Tilt the fan assembly to fit its back panel through the opening in the dividing wall.

EnergyX

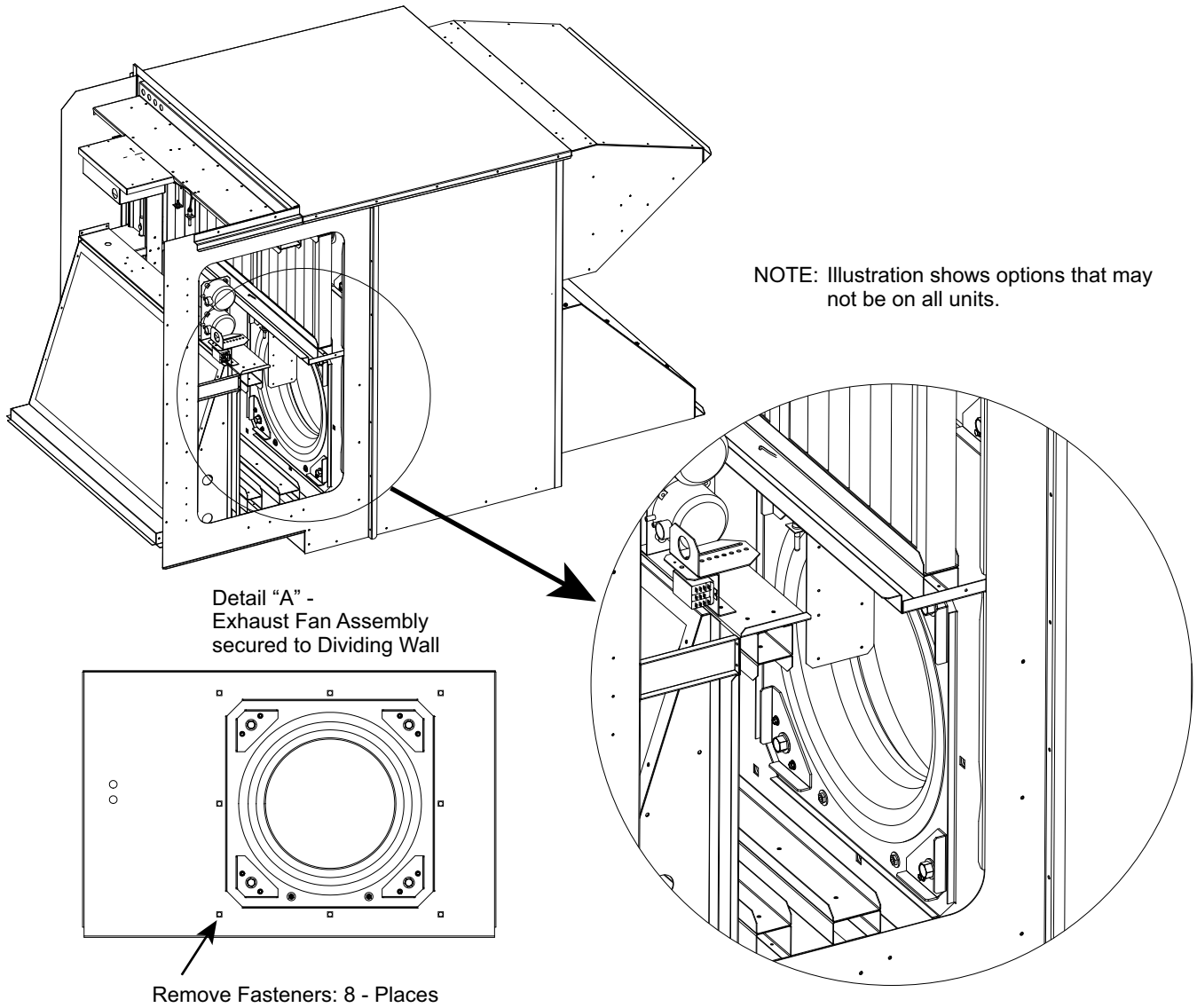
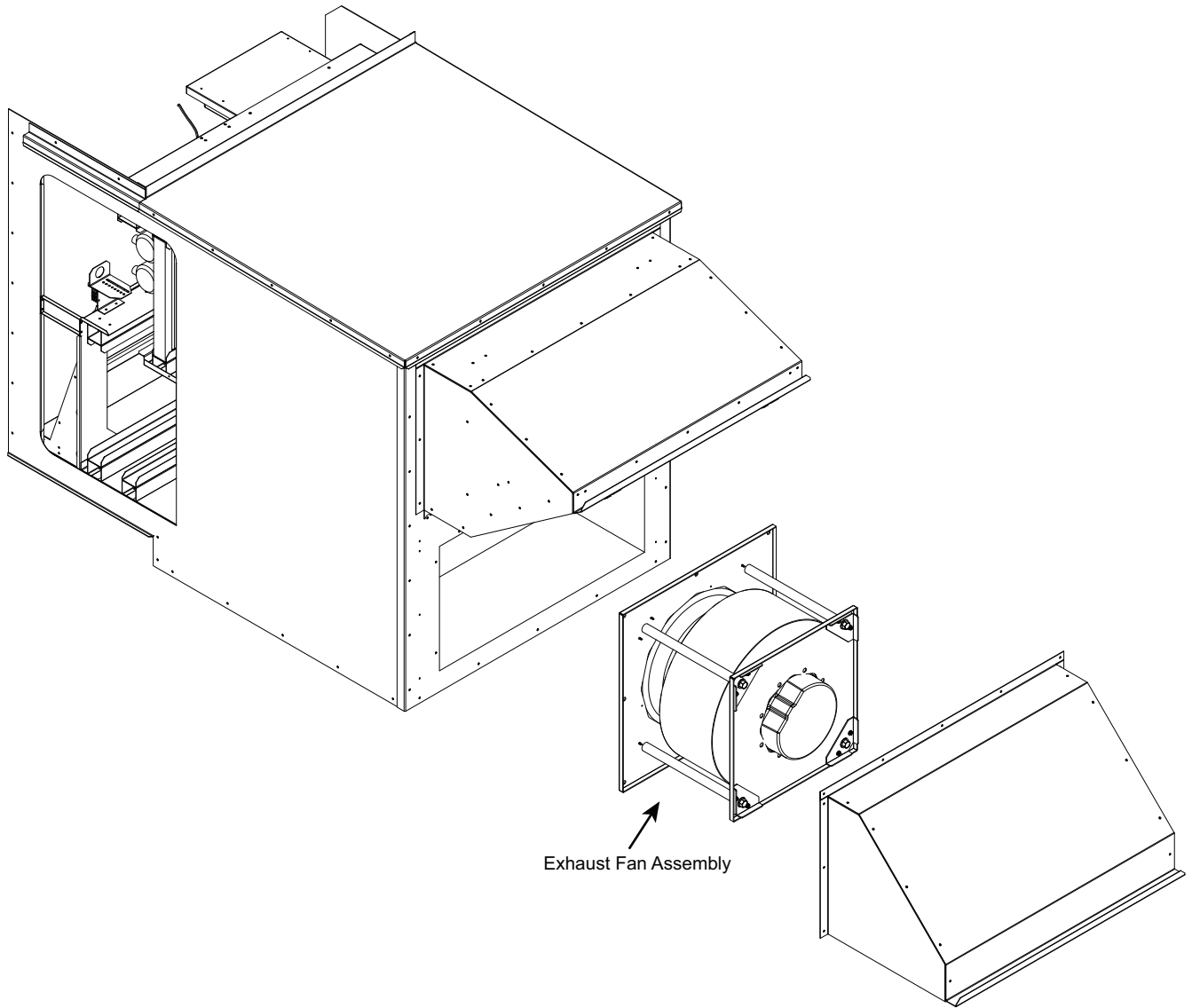

Fig. 20 - Exhaust Fan Assembly - Fastener Locations

C13637



Exhaust Fan Assembly

Fig. 21 - Exhaust Fan Assembly - Removal

C13031

APPENDIX

Appendix A — Certified Dimension Drawings

Appendix B — Exhaust Fan Performance Curves

EnergyX Modulating Volume 12.5 Ton Units

Appendix C — Electrical Data:

Table 8 - 48HC with ERV:
Unit Wire/Fuse or HACR Breaker Sizing Data

Table 9 - 48HC with ERV and Factory-Installed
HACR Breaker

Table 10 - 48HC with ERV and 2-Speed Indoor Fan
Option

Table 11 - 48HC with ERV, Factory-Installed HACR
Breaker and 2-Speed Indoor Fan Option

Table 12 - 50HC with Electric Heat and ERV:
Unit Wire/Fuse or HACR Breaker Sizing Data

Table 13 - 50HC with Electric Heat, ERV and
Factory-Installed HACR Breaker

Table 14 - 50HC with Electric Heat, ERV and 2-Speed
Indoor Fan Option

Table 15 - 50HC with Electric Heat, ERV,
Factory-Installed HACR Breaker and
2-Speed Indoor Fan Option

Appendix D — I/O Flex 6126 Installation Guide

Appendix E — Carrier BACview/Virtual BACview Commissioning

APPENDIX A — CERTIFIED DIMENSION DRAWINGS

NOTES:
 1. DIMENSIONS ARE IN INCHES. DIMENSIONS IN [] ARE IN MILLIMETERS.
 2. CENTER OF GRAVITY
 3. DIRECTION OF AIR FLOW

UNITED TECHNOLOGIES STRACURE, NY CORPORATION'S WRITTEN CONSENT.
 P.O. BOX 4888
 13221

THIS DOCUMENT IS THE PROPERTY OF CARRIER CORPORATION AND IS NOT TO BE REPRODUCED OR TRANSMITTED IN ANY FORM OR BY ANY MEANS, ELECTRONIC OR MECHANICAL, WITHOUT THE WRITTEN CONSENT OF CARRIER CORPORATION. SUBMISSION OF THESE DRAWINGS OR DOCUMENTS DOES NOT CONSTITUTE PART PERFORMANCE OR ACCEPTANCE OF CONTRACT.

CONNECTION SIZES	
B	2 1/2" - 1641 DIA POWER SUPPLY HOLE
D	7/8" - E221 DIA FIELD CONTROL WIRING HOLE
E	3/4" - 14 NPT CONDENSATE DRAIN
F	7/8" - E221 DIA FIELD CONNECTION OUTLET HOLE
G	3/4" - 14 NPT GAS CONNECTION

THRU-THE-BASE CHART THESE HOLES REQUIRED FOR USE CRBTPWR005A00-006A00-007A00			
ACCESSORY NO.	THREADED CONDUIT SIZE	WIRE USE	REQ'D HOLE SIZES (MAX.)
005	W 1/2"	ACC.	7/8" [22.2]
	X 1/2"	24V	7/8" [22.2]
	Y 1/4"	POWER	1 1/2" [38.1]
006	W 1/2"	ACC.	7/8" [22.2]
	X 1/2"	24V	7/8" [22.2]
	Y 1/4"	POWER	1 1/2" [38.1]
007	W 1/2"	ACC.	7/8" [22.2]
	X 1/2"	24V	7/8" [22.2]
	Y 1/4"	POWER	1 1/2" [38.1]

FOR "THRU-THE-BASE" FACTORY OPTION, FITTINGS FOR X & Y ARE PROVIDED AS SPECIFIED ON "006".

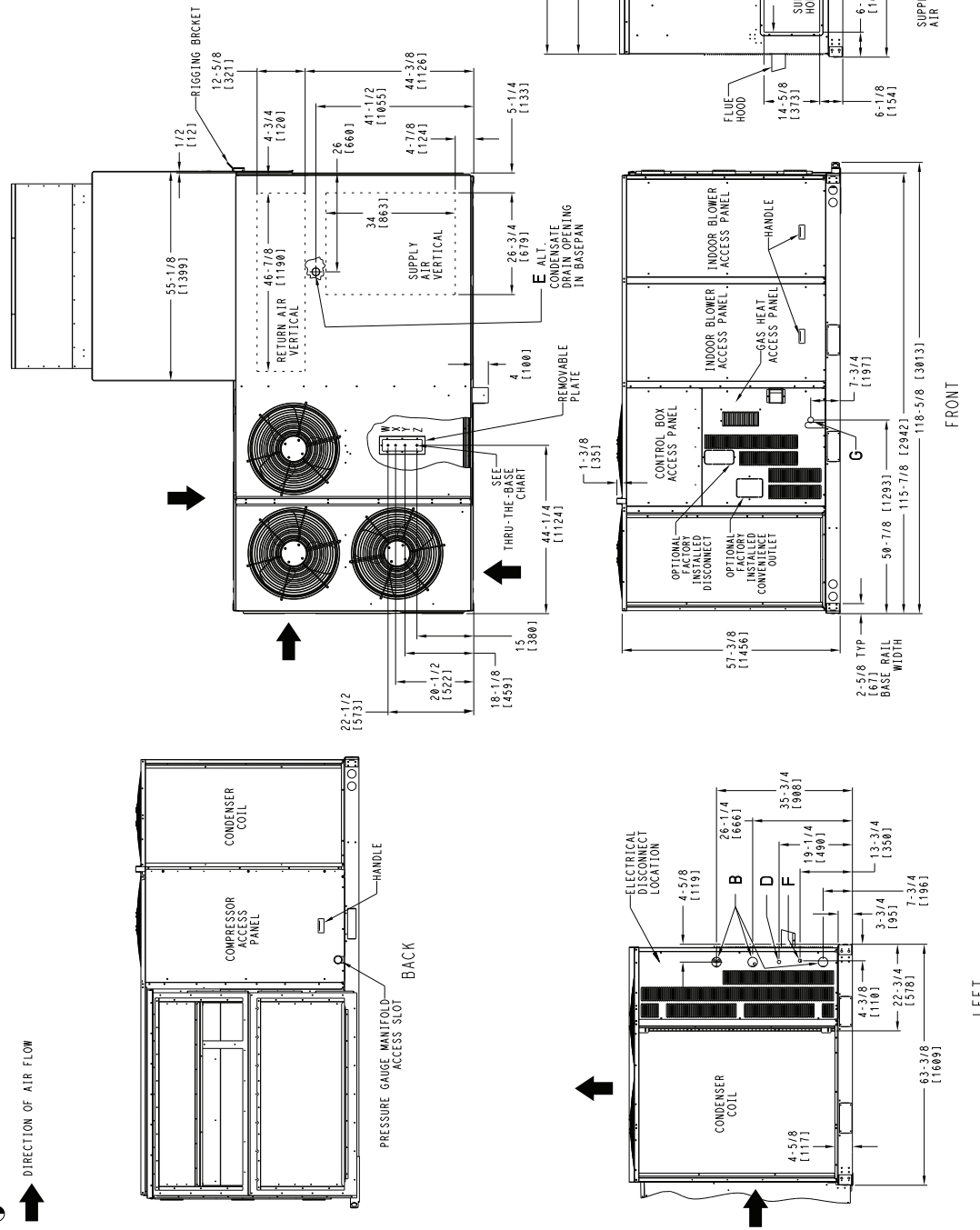

DATE	SUPRECEDES	TARGET 48HCD 14 SINGLE ZONE ELECTRICAL COOLING WITH GAS HEAT AND ERV	REV
11/15/12			50TM501816

Fig. 22 - 48HC-14 Single Zone Electric Cooling with Gas Heat and ERV (Sheet 1 of 2)



APPENDIX A — CERTIFIED DIMENSION DRAWINGS

UNIT	CORNER WEIGHT (A)		CORNER WEIGHT (B)		CORNER WEIGHT (C)		CORNER WEIGHT (D)		C.G.				
	LBS.	KG.	LBS.	KG.	LBS.	KG.	LBS.	KG.	X	Y	Z		
48HCD 14	2534	1152	782	356	1332	605	264	120	155	71	73-1/8 (1856)	10 1/2 (267)	28 5/8 (525)

STANDARD UNIT WEIGHT IS WITH LOW HEAT & WITHOUT PACKAGING. FOR OPTIONS & ACCESSORIES, REFER TO THE PRODUCT DATA CATALOG.

 UNITED TECHNOLOGIES SYRACUSE, NY 13221
 P.O. BOX 4888
 THIS DOCUMENT IS THE PROPERTY OF CARRIER CORPORATION AND IS DELIVERED UPON THE EXPRESS CONDITION THAT THE USER WILL NOT REPRODUCE, COPY, OR USE WITHOUT CARRIER CORPORATION'S WRITTEN CONSENT.
 SUBMISSION OF THESE DRAWINGS OR SPECIFICATIONS DOES NOT CONSTITUTE AN ACCEPTANCE OF CONTRACT.

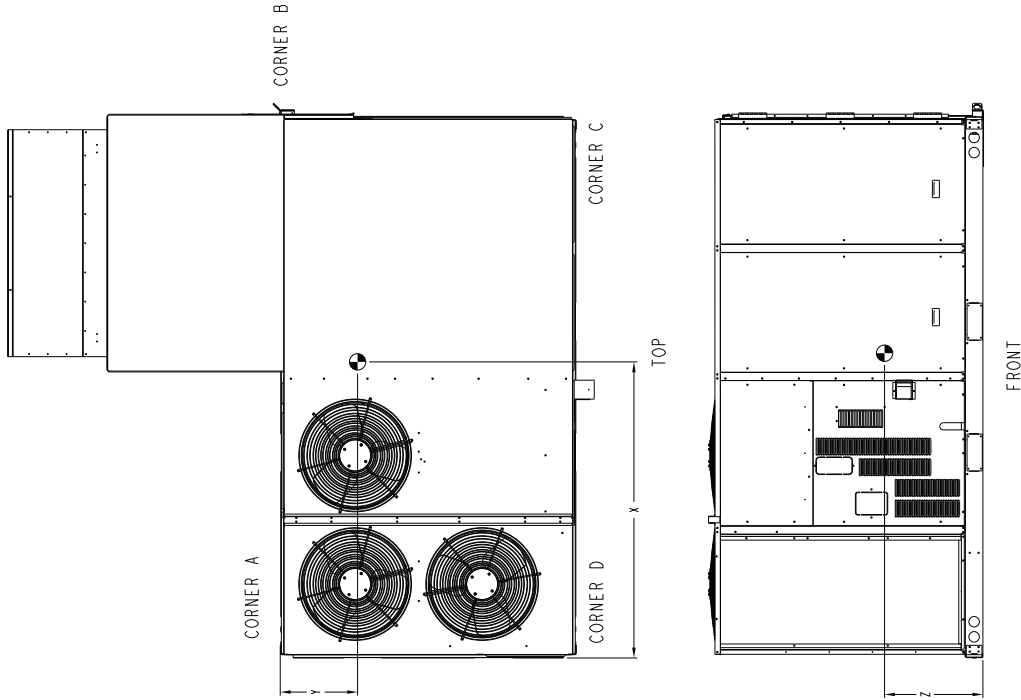

DATE	SUPERCEDS	REV
03/08/12	-	50TMS01816

Fig. 23 - 48HC-14 Single Zone Electric Cooling with Gas Heat and ERV (Sheet 2 of 2)

APPENDIX A — CERTIFIED DIMENSION DRAWINGS

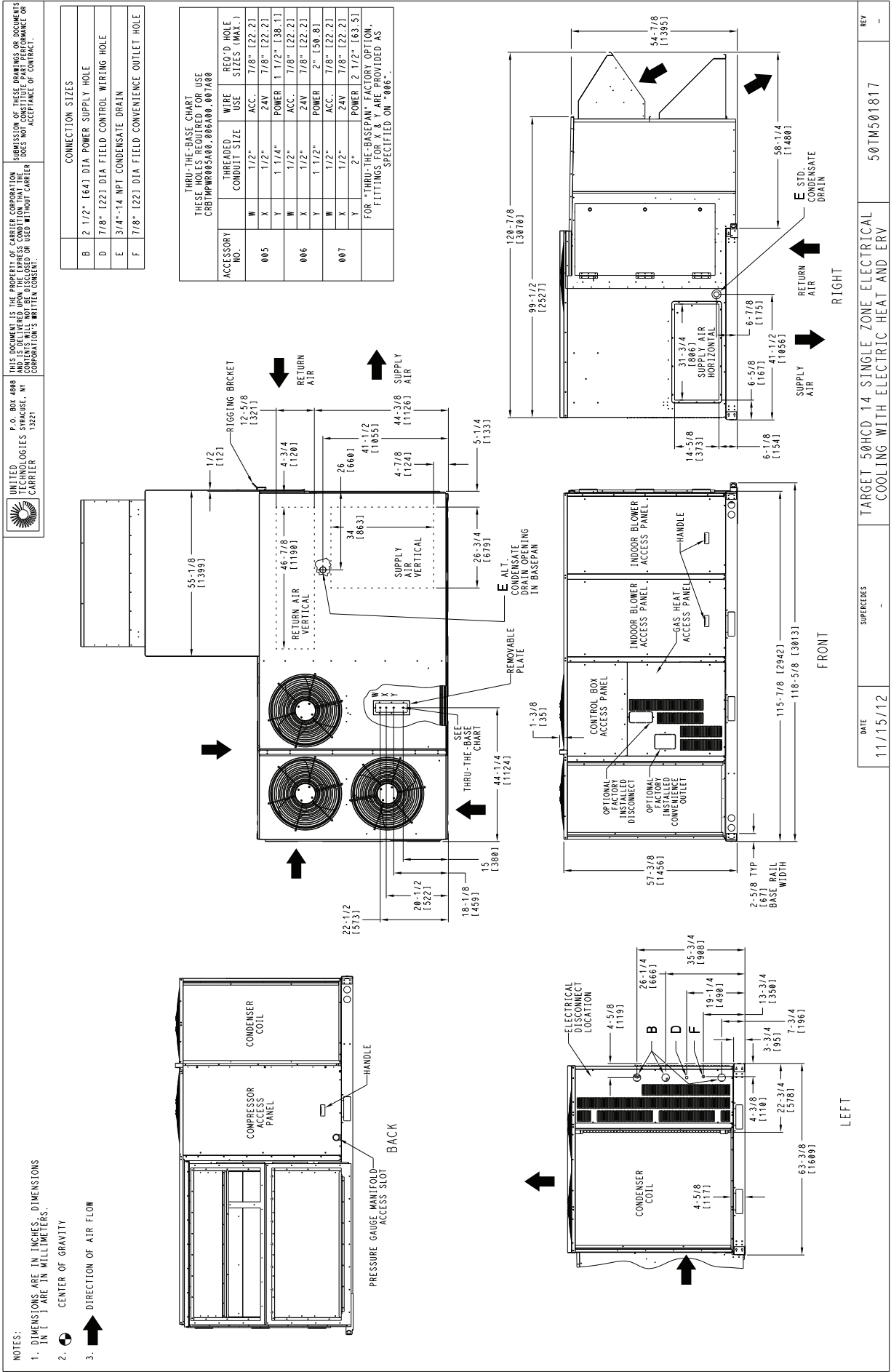

Fig. 24 - 50HC-14 Single Zone Electric Cooling with Electric Heat and ERV (Sheet 1 of 2)



APPENDIX A — CERTIFIED DIMENSION DRAWINGS

UNIT	STD UNIT WEIGHT		CORNER WEIGHT (A)		CORNER WEIGHT (B)		CORNER WEIGHT (C)		CORNER WEIGHT (D)		C.G.				
	LBS.	KG.	LBS.	KG.	LBS.	KG.	LBS.	KG.	LBS.	KG.	X	Y	Z		
50HCD 14	2464	1120	774	352	1316	598	235	107	138	63	73	118	21	1/8	(.537)

STANDARD UNIT WEIGHT IS WITHOUT ELECTRIC HEAT & WITHOUT PACKAGING. FOR OPTIONS & ACCESSORIES, REFER TO THE PRODUCT DATA CATALOG.

UNITED TECHNOLOGIES SYRACUSE, NY
CARRIER

P.O. BOX 4888
13221

THIS DOCUMENT IS THE PROPERTY OF CARRIER CORPORATION AND IS DELIVERED UPON THE EXPRESS CONDITION THAT THE USER WILL NOT REPRODUCE, COPY, OR USE WITHOUT CARRIER CORPORATION'S WRITTEN CONSENT.

SUBMISSION OF THESE DRAWINGS OR SPECIFICATIONS DOES NOT CONSTITUTE AN ACCEPTANCE OF CONTRACT.

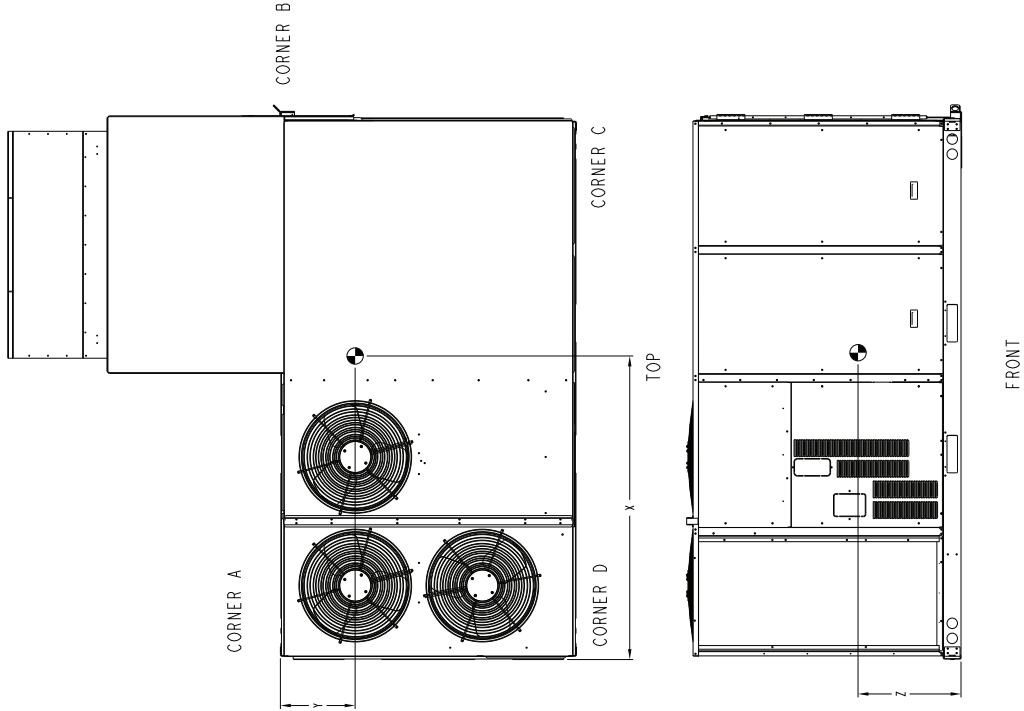

DATE	SUPERCEDS	TARGET 50HCD 14 SINGLE ZONE ELECTRICAL COOLING WITH ELECTRIC HEAT AND ERV	REV
03/08/12	-		50TMS01817

Fig. 25 - 50HC-14 Single Zone Electric Cooling with Electric Heat and ERV (Sheet 2 of 2)

APPENDIX B — EXHAUST FAN PERFORMANCE

Many applications that utilize energy recovery incorporate ducted return/exhaust air paths. In these applications it is important to consider the duct pressure of the return/exhaust just as a designer would consider the effects of the supply duct static pressure on the airflow of the rooftop unit itself.

EnergyX Modulating Volume 12.5 Ton Units

The exhaust fan in the Modulated Volume EnergyX unit will assist the rooftop unit fan in pulling air through the

exhaust/return duct. These exhaust fans are backwards curved impeller designs which are capable of significant more static pressure operation than typical forward curved fan designs. The following exhaust fan performance curve is provided for additional guidance when considering return/exhaust duct design.

NOTE: If application designs require two separate ducts (one for exhaust air, one for return air) contact your Carrier Sales Engineer for additional guidance prior to specification or ordering.

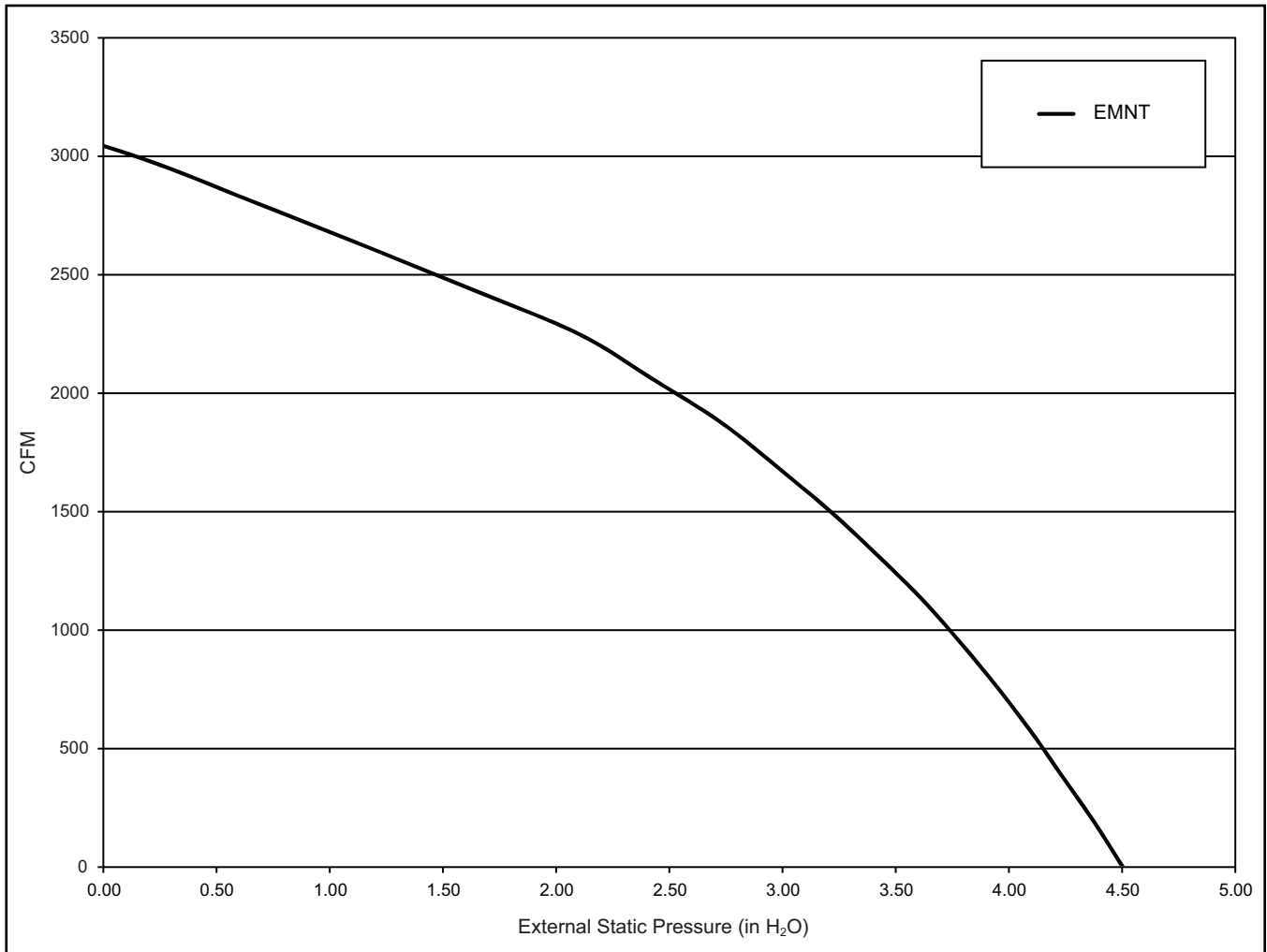

EnergyX

Fig. 29 - 12.5 Ton SRT Unit ERV Exhaust Fan Performance Curve

C12785

APPENDIX C — ELECTRICAL DATA

Table 8 – 48HC - with ERV: Unit Wire/Fuse or HACR Breaker Sizing Data

UNIT	IFM TYPE	NO C.O. or UNPWR C.O.																			
		w/ERV w/o Economizer						w/ERV w/Economizer													
		MCA	HACR BRKR	DISC. SIZE		MCA	HACR BRKR	DISC. SIZE		MCA	HACR BRKR	DISC. SIZE									
48HC* D14	208/230-3-60	72/72	80/80	77/77	346	346	72/72	80/80	77/77	346	346	77/77	83/83	351	351	77/77	90/90	83/83	351	351	
		74	80	80	360	360	74	80	80	360	360	74	80	85	365	365	79	90	85	365	365
		85	100	91	366	366	85	100	91	366	366	89	100	96	371	371	89	100	96	371	371
460-3-60	460-3-60	36	45	38	173	173	36	45	38	173	173	38	45	41	175	175	38	45	41	175	175
		37	45	39	180	180	37	45	39	180	180	39	45	42	182	182	39	45	42	182	182
		42	50	45	183	183	42	50	45	183	183	44	50	47	185	185	44	50	47	185	185
575-3-60	575-3-60	29	35	31	135	135	29	35	31	135	135	31	35	33	137	137	31	35	33	137	137
		29	35	31	135	135	29	35	31	135	135	31	35	33	137	137	31	35	33	137	137
		36	40	38	147	147	36	40	38	147	147	37	45	40	149	149	37	45	40	149	149

See: "Legend and Notes for Tables 8 – 15 on page 46.

APPENDIX C — ELECTRICAL DATA

Table 9 – 48HC - with ERV and Factory-Installed HACR Breaker

UNIT	NOM. V-PH-HZ	IFM TYPE	NO C.O. or UNPWR C.O.																			
			w/ERV w/o Economizer						w/ERV w/Economizer						w/ PWRD C.O.							
			MCA	HACR BRKR	DISC. SIZE		HACR BRKR	MCA	HACR BRKR	DISC. SIZE		HACR BRKR	MCA	HACR BRKR	DISC. SIZE		HACR BRKR	MCA	HACR BRKR	DISC. SIZE		
		FLA	LRA					FLA	LRA					FLA	LRA			FLA	LRA			
48HC* D14	208/230-3-60	STD	72/72	80/80	77/77	346	346	77/77	80/80	80/80	346	346	77/77	80/90	83/83	351	351	77/77	90/90	83/83	351	351
		MED	74	80	80	360	360	80	80	80	74	360	360	90	85	365	365	79	90	85	365	365
		HIGH	85	100	91	366	366	91	100	100	85	366	366	100	96	371	371	89	100	96	371	371
48HC* D14	460-3-60	STD	36	45	38	173	173	38	45	45	173	173	38	45	41	175	175	38	45	41	175	175
		MED	37	45	39	180	180	39	45	45	37	180	180	45	42	182	182	39	45	42	182	182
		HIGH	42	50	45	183	183	45	50	50	42	183	183	50	47	185	185	44	50	47	185	185
48HC* D14	575-3-60	STD	29	35	31	135	135	31	35	35	135	135	31	35	33	137	137	31	35	33	137	137
		MED	29	35	31	135	135	31	35	35	29	135	135	35	33	137	137	31	35	33	137	137
		HIGH	36	40	38	147	147	38	40	40	36	147	147	45	40	149	149	37	45	40	149	149

See: "Legend and Notes for Tables 8 – 15 on page 46.



APPENDIX C — ELECTRICAL DATA

Table 10 – 48HC - with ERV and 2-Speed Indoor Fan Option

UNIT	IFM TYPE	NO C.O. or UNPWR C.O.												w/ PWRD C.O.																	
		w/ERV w/o Economizer						w/ERV w/Economizer						w/ERV w/o Economizer						w/ERV w/Economizer											
		MCA	MAX FUSE or HACR BRKR	FLA	DISC. SIZE	LRA		MCA	MAX FUSE or HACR BRKR	FLA	DISC. SIZE	LRA		MCA	MAX FUSE or HACR BRKR	FLA	DISC. SIZE	LRA		MCA	MAX FUSE or HACR BRKR	FLA	DISC. SIZE	LRA							
48HC* D14	208/230-3-60	72/72	80/80	77/76	327		72/72	80/80	77/76	327		72/72	80/80	77/76	327		72/72	80/80	77/76	327		72/76	90/90	83/82	332		77/76	90/90	83/82	332	
	208/230-3-60	75/74	80/80	80/79	351		75/74	80/80	80/79	351		75/74	80/80	80/79	351		79/78	90/90	85/84	356		79/78	90/90	85/84	356		79/78	90/90	85/84	356	
	208/230-3-60	85	100	91	366		85	100	91	366		85	100	91	366		89	100	96	371		89	100	96	371		89	100	96	371	
48HC* D14	460-3-60	36	40	38	164		36	40	38	164		36	40	38	164		38	45	40	166		38	45	40	166		38	45	40	166	
	460-3-60	37	45	39	176		37	45	39	176		37	45	39	176		39	45	41	178		39	45	41	178		39	45	41	178	
	460-3-60	42	50	45	183		42	50	45	183		42	50	45	183		44	50	47	185		44	50	47	185		44	50	47	185	
575-3-60	575-3-60	31	35	33	135		31	35	33	135		31	35	33	135		32	35	35	137		32	35	35	137		32	35	35	137	
	575-3-60	31	35	33	135		31	35	33	135		31	35	33	135		32	35	35	137		32	35	35	137		32	35	35	137	
	575-3-60	36	40	38	147		36	40	38	147		36	40	38	147		37	45	40	149		37	45	40	149		37	45	40	149	

See: "Legend and Notes for Tables 8 – 15 on page 46."

APPENDIX C — ELECTRICAL DATA

Table 11 – 48HC - with ERV, Factory-Installed HACR Breaker and 2-Speed Indoor Fan Option

UNIT	NOM. V-PH-Hz	IFM TYPE	NO C.O. or UNPWR C.O.						w/ PWRD C.O.									
			w/ERV w/o Economizer			w/ERV w/Economizer			w/ERV w/o Economizer			w/ERV w/Economizer						
			MCA	HACR BRKR	DISC. SIZE FLA LRA	MCA	HACR BRKR	DISC. SIZE FLA LRA	MCA	HACR BRKR	DISC. SIZE FLA LRA	MCA	HACR BRKR	DISC. SIZE FLA LRA				
48HC* D14	208/230-3-60	STD	72/72	80/80	77/76	327	72/72	80/80	77/76	327	77/77	90/90	83/82	332	77/77	90/90	83/82	332
		MED	75/75	80/80	80/79	351	75/75	80/80	80/79	351	79/79	90/90	85/84	356	79/79	90/90	85/84	356
		HIGH	85	100	91	366	85	100	91	366	89	100	96	371	89	100	96	371
460-3-60	460-3-60	STD	36	40	38	164	36	40	38	164	38	45	40	166	38	45	40	166
		MED	37	45	39	176	37	45	39	176	39	45	41	178	39	45	41	178
		HIGH	42	50	45	183	42	50	45	183	44	50	47	185	44	50	47	185
575-3-60	575-3-60	STD	31	35	33	135	31	35	33	135	32	35	35	137	32	35	35	137
		MED	31	35	33	135	31	35	33	135	32	35	35	137	32	35	35	137
		HIGH	36	40	38	147	36	40	38	147	37	45	40	149	37	45	40	149

See: "Legend and Notes for Tables 8 – 15 on page 46.



APPENDIX C — ELECTRICAL DATA

Table 12 - 50HC - With Electric Heat and ERV: Unit Wire/Fuse or HACR Breaker Sizing Data (cont.)

UNIT	NOM. V-PH-Hz	IFM TYPE	ELEC. HTR		NO C.O. or UNPWR C.O.																				
			CRHEATER	Nom (kW)	FLA	w/ERV w/o Economizer				w/ERV w/o Economizer				w/ERV w/Economizer											
						MCA	MAX FUSE or HACR BRKR	FLA	DISC. SIZE	LRA	MCA	MAX FUSE or HACR BRKR	FLA	DISC. SIZE	LRA	MCA	MAX FUSE or HACR BRKR	FLA	DISC. SIZE	LRA					
50HC* D14 (cont)	575-3-60	STD	NONE	-	-	29	35	31	135	135	29	35	31	135	135	31	35	33	137	137	31	35	33	137	137
			293A	15.9	15.9	33	35	31	135	135	33	35	31	135	135	33	35	33	137	137	35	35	33	137	137
			290A+293A	26.5	25.5	45	45	41	135	135	45	45	41	135	135	47	50	43	137	137	47	50	43	137	137
			296A	33.5	32.2	53	60	48	135	135	53	60	48	135	135	55	60	50	137	137	55	60	50	137	137
		290A+296A	43.5	41.8	65	70	59	135	135	65	70	59	135	135	67	70	61	70	137	137	67	70	61	137	137
		293A+296A	50.0	48.1	61	70	67	135	135	61	70	67	135	135	63	70	69	70	137	137	63	70	69	137	137
		NONE	-	-	29	35	31	135	135	29	35	31	135	135	31	35	33	137	137	31	35	33	137	137	
		293A	16.5	15.9	33	35	31	135	135	33	35	31	135	135	35	35	33	137	137	35	35	33	137	137	
		290A+293A	26.5	25.5	45	45	41	135	135	45	45	41	135	135	47	50	43	137	137	47	50	43	137	137	
		296A	33.5	32.2	53	60	48	135	135	53	60	48	135	135	55	60	50	137	137	55	60	50	137	137	
		290A+296A	43.5	41.8	65	70	59	135	135	65	70	59	135	135	67	70	61	70	137	137	67	70	61	137	137
		293A+296A	50.0	48.1	61	70	67	135	135	61	70	67	135	135	63	70	69	70	137	137	63	70	69	137	137
HIGH	NONE	-	-	36	40	38	147	147	36	40	38	147	147	37	45	40	149	149	37	45	40	149	149		
	293A	16.5	15.9	40	40	38	147	147	40	40	38	147	147	42	45	40	149	149	42	45	40	149	149		
	290A+293A	26.5	25.5	52	60	48	147	147	52	60	48	147	147	54	60	50	149	149	54	60	50	149	149		
	296A	33.5	32.2	61	70	55	147	147	61	70	55	147	147	63	70	57	149	149	63	70	57	149	149		
290A+296A	43.5	41.8	73	80	67	147	147	73	80	67	147	147	75	80	68	149	149	75	80	68	149	149			
293A+296A	50.0	48.1	69	70	74	147	147	69	70	74	147	147	71	80	76	149	149	71	80	76	149	149			

See: "Legend and Notes for Tables 8 - 15 on page 46.



APPENDIX C — ELECTRICAL DATA

Table 13 - 50HC - With Electric Heat, ERV and Factory-Installed HACR Breaker Sizing Data (cont.)

UNIT	IFM TYPE	ELEC. HTR			NO C.O. or UNPWR C.O.												w/ PWRD C.O.																														
		CRHEATER	Nom (kW)	FLA	w/ERV w/o Economizer				w/ERV w/Economizer				w/ERV w/o Economizer				w/ERV w/Economizer																														
					MCA	HACR BRKR	FLA	DISC. SIZE	LRA	MCA	HACR BRKR	FLA	DISC. SIZE	LRA	MCA	HACR BRKR	FLA	DISC. SIZE	LRA	MCA	HACR BRKR	FLA	DISC. SIZE	LRA																							
50HC+ D14 (cont)	STD	NONE	-	-	29	35	31	135	135	31	35	31	135	135	29	35	31	135	135	31	35	31	135	135	31	35	31	137	137	31	35	31	137	137	31	35	31	137	137								
		293A	16.5	15.9	33	35	31	135	135	31	35	31	135	135	33	35	31	135	135	31	35	31	135	135	33	35	31	137	137	33	35	31	137	137	33	35	31	137	137								
		290A+293A	26.5	25.5	45	45	41	135	135	41	45	41	135	135	45	45	41	135	135	41	45	41	135	135	47	47	43	47	43	47	47	43	47	43	47	43	47	43	47	43	47	43					
		296A	33.5	32.2	53	60	48	135	135	48	60	48	135	135	53	60	48	135	135	48	60	48	135	135	55	55	50	55	50	55	50	55	50	55	50	55	50	55	50	55	50	55					
		290A+296A	43.5	41.8	65	70	59	135	135	59	70	59	135	135	65	70	59	135	135	59	70	59	135	135	67	67	61	67	61	67	61	67	61	67	61	67	61	67	61	67	61	67	61				
		293A+296A	50.0	48.1	61	70	67	135	135	67	70	67	135	135	61	70	67	135	135	67	70	67	135	135	63	63	69	63	69	63	69	63	69	63	69	63	69	63	69	63	69	63	69	63			
	MED	NONE	-	-	29	35	31	135	135	31	35	31	135	135	29	35	31	135	135	31	35	31	135	135	31	35	31	137	137	31	35	31	137	137	31	35	31	137	137	31	35	31	137	137			
		293A	16.5	15.9	33	35	31	135	135	31	35	31	135	135	33	35	31	135	135	31	35	31	135	135	33	35	31	137	137	33	35	31	137	137	33	35	31	137	137	33	35	31	137	137			
		290A+293A	26.5	25.5	45	45	41	135	135	41	45	41	135	135	45	45	41	135	135	41	45	41	135	135	47	47	43	47	43	47	43	47	43	47	43	47	43	47	43	47	43	47	43	47	43		
		296A	33.5	32.2	53	60	48	135	135	48	60	48	135	135	53	60	48	135	135	48	60	48	135	135	55	55	50	55	50	55	50	55	50	55	50	55	50	55	50	55	50	55	50	55	50	55	
		290A+296A	43.5	41.8	65	70	59	135	135	59	70	59	135	135	65	70	59	135	135	59	70	59	135	135	67	67	61	67	61	67	61	67	61	67	61	67	61	67	61	67	61	67	61	67	61	67	61
		293A+296A	50.0	48.1	61	70	67	135	135	67	70	67	135	135	61	70	67	135	135	67	70	67	135	135	63	63	69	63	69	63	69	63	69	63	69	63	69	63	69	63	69	63	69	63	69	63	
HIGH	NONE	-	-	36	40	38	147	147	38	40	38	147	147	36	40	38	147	147	38	40	38	147	147	37	37	40	37	40	37	40	37	40	37	40	37	40	37	40	37	40	37	40	37	40	37	40	
	293A	16.5	15.9	40	40	38	147	147	38	40	38	147	147	40	40	38	147	147	38	40	38	147	147	42	42	40	42	40	42	40	42	40	42	40	42	40	42	40	42	40	42	40	42	40	42	40	
	290A+293A	26.5	25.5	52	60	48	147	147	48	60	48	147	147	52	60	48	147	147	48	60	48	147	147	54	54	50	54	50	54	50	54	50	54	50	54	50	54	50	54	50	54	50	54	50	54		
	296A	33.5	32.2	61	70	55	147	147	55	70	55	147	147	61	70	55	147	147	55	70	55	147	147	63	63	70	63	70	63	70	63	70	63	70	63	70	63	70	63	70	63	70	63	70	63		
	290A+296A	43.5	41.8	73	80	67	147	147	67	80	67	147	147	73	80	67	147	147	67	80	67	147	147	75	75	80	75	80	75	80	75	80	75	80	75	80	75	80	75	80	75	80	75	80			
	293A+296A	50.0	48.1	69	70	74	147	147	74	70	74	147	147	69	70	74	147	147	74	70	74	147	147	71	71	80	71	80	71	80	71	80	71	80	71	80	71	80	71	80	71	80	71	80			

See: "Legend and Notes for Tables 8 - 15 on page 46.



APPENDIX C — ELECTRICAL DATA

Table 14 - 50HC - With Electric Heat, ERV and 2-Speed Indoor Fan Option (cont.)

UNIT	NOM. V-PH-Hz	IFM TYPE	ELEC. HTR			w/ PWRD C.O.																				
			CRHEATER	Nom (kW)	FLA	NO C.O. or UNPWR C.O.				w/ERV w/o Economizer				w/ERV w/Economizer												
						MAX FUSE or HACR BRKR	FLA	DISC. SIZE	LRA	MCA	MAX FUSE or HACR BRKR	FLA	DISC. SIZE	LRA	MCA	MAX FUSE or HACR BRKR	FLA	DISC. SIZE	LRA							
50HC* D14 (cont)	575-1-3-60	STD	NONE	-	-	31	35	33	135	31	35	33	135	32	35	35	137	32	35	35	137	35	35	137		
			293A	16.5	15.9	35	35	33	135	35	35	33	135	37	40	37	40	35	37	40	35	35	137	35	137	
			290A+293A	26.5	25.5	47	50	43	47	50	43	47	50	49	50	49	50	50	45	49	50	45	45	50	45	137
			296A	33.5	32.2	55	60	50	55	60	50	55	60	57	60	57	60	60	52	57	60	52	57	60	52	137
			290A+296A	43.5	41.8	67	70	61	67	70	61	67	70	69	70	69	70	70	63	69	70	63	69	70	63	137
			293A+296A	50.0	48.1	83	70	69	63	70	69	63	70	65	71	65	70	70	71	65	65	70	71	65	71	65
		MED	NONE	-	-	31	35	33	135	31	35	33	135	32	35	35	35	137	32	35	35	137	35	35	137	
			293A	16.5	15.9	35	35	33	135	35	35	33	135	37	40	37	40	35	37	40	35	37	40	35	35	137
			290A+293A	26.5	25.5	47	50	43	47	50	43	47	50	49	50	49	50	45	49	50	45	45	50	45	45	137
			296A	33.5	32.2	55	60	50	55	60	50	55	60	57	60	57	60	60	52	57	60	52	57	60	52	137
			290A+296A	43.5	41.8	67	70	61	67	70	61	67	70	69	70	69	70	70	63	69	70	63	69	70	63	137
			293A+296A	50.0	48.1	83	70	69	63	70	69	63	70	65	71	65	70	70	71	65	65	70	71	65	71	65
HIGH	NONE	-	-	36	40	38	147	36	40	38	147	37	45	37	45	40	37	45	40	37	45	40	37	45	149	
	293A	16.5	15.9	40	40	38	147	40	40	38	147	42	45	42	45	40	42	45	40	42	45	40	42	45	149	
	290A+293A	26.5	25.5	52	60	48	52	60	48	52	54	60	50	54	60	50	50	54	60	50	54	60	50	54	149	
	296A	33.5	32.2	61	70	55	61	70	55	61	63	70	57	63	70	57	57	63	70	57	63	70	57	63	149	
	290A+296A	43.5	41.8	73	80	67	73	80	67	73	75	80	68	75	80	80	68	75	80	68	75	80	68	75	149	
	293A+296A	50.0	48.1	89	70	74	69	70	74	69	69	71	74	69	70	70	74	69	71	70	74	69	71	74	149	

See: "Legend and Notes for Tables 8 - 15 on page 46.



APPENDIX C — ELECTRICAL DATA

Table 15 - 50HC - With Electric Heat, ERV, Factory-Installed HACR Breaker and 2-Speed Indoor Fan Option (cont.)

UNIT	NOM. V-PH-Hz	IFM TYPE	ELEC. HTR		NO C.O. or UNPWR C.O.																								
			CRHEATER	Nom (kW)	FLA	w/ERV w/o Economizer				w/ERV w/Economizer				w/ERV w/o Economizer				w/ERV w/Economizer											
						MCA	HACR BRKR	DISC. SIZE FLA LRA	MCA	HACR BRKR	DISC. SIZE FLA LRA	MCA	HACR BRKR	DISC. SIZE FLA LRA	MCA	HACR BRKR	DISC. SIZE FLA LRA	MCA	HACR BRKR	DISC. SIZE FLA LRA									
50HC* D14 (cont)		STD	NONE	-	-	31	35	33	135	31	35	33	135	32	35	33	135	32	35	33	137	32	35	33	137	37	40	35	137
			296A	16.5	15.9	35	35	33	135	35	35	33	135	37	40	35	137	37	40	35	137	37	40	35	137	37	40	35	137
			290A+293A	26.5	25.5	47	50	43	135	47	50	43	135	49	50	45	137	49	50	45	137	49	50	45	137	49	50	45	137
			296A	33.5	32.2	60	60	50	135	60	60	50	135	57	60	52	137	57	60	52	137	57	60	52	137	57	60	52	137
			290A+296A	43.5	41.8	67	70	61	135	67	70	61	135	69	70	63	137	69	70	63	137	69	70	63	137	69	70	63	137
			293A+296A	50.0	48.1	63	70	69	135	70	70	69	135	65	70	71	137	65	70	71	137	65	70	71	137	65	70	71	137
		MED	NONE	-	-	31	35	33	135	31	35	33	135	32	35	33	135	32	35	33	137	32	35	33	137	37	40	35	137
			293A	16.5	15.9	35	35	33	135	35	35	33	135	37	40	35	137	37	40	35	137	37	40	35	137	37	40	35	137
			290A+293A	26.5	25.5	47	50	43	135	47	50	43	135	49	50	45	137	49	50	45	137	49	50	45	137	49	50	45	137
			296A	33.5	32.2	60	60	50	135	60	60	50	135	57	60	52	137	57	60	52	137	57	60	52	137	57	60	52	137
			290A+296A	43.5	41.8	67	70	61	135	67	70	61	135	69	70	63	137	69	70	63	137	69	70	63	137	69	70	63	137
			293A+296A	50.0	48.1	63	70	69	135	70	70	69	135	65	70	71	137	65	70	71	137	65	70	71	137	65	70	71	137
HIGH	NONE	-	-	36	40	38	147	36	40	38	147	37	45	40	149	37	45	40	149	37	45	40	149	42	45	40	149		
	293A	16.5	15.9	40	40	38	147	40	40	38	147	42	45	40	149	42	45	40	149	42	45	40	149	42	45	40	149		
	290A+293A	26.5	25.5	52	60	48	147	52	60	48	147	54	60	50	149	54	60	50	149	54	60	50	149	54	60	50	149		
	296A	33.5	32.2	61	70	55	147	61	70	55	147	63	70	57	149	63	70	57	149	63	70	57	149	63	70	57	149		
	290A+296A	43.5	41.8	73	80	67	147	73	80	67	147	75	80	68	149	75	80	68	149	75	80	68	149	75	80	68	149		
	293A+296A	50.0	48.1	69	70	74	147	69	70	74	147	71	80	76	149	71	80	76	149	71	80	76	149	71	80	76	149		

See: "Legend and Notes for Tables 8 - 15 on page 46.



Legend and Notes for Tables 8 - 15

LEGEND:

BRKR	-	Circuit breaker
CO	-	Convenient outlet
DISC	-	Disconnect
FLA	-	Full load amps
IFM	-	Indoor fan motor
LRA	-	Locked rotor amps
MCA	-	Minimum circuit amps
MOCP	-	MAX FUSE or HACR Breaker
PE	-	Power exhaust
PWRD CO	-	Powered convenient outlet
UNPWR CO	-	Unpowered convenient outlet

NOTES:

1. In compliance with NEC requirements for multimotor and combination load equipment (refer to NEC Articles 430 and 440), the overcurrent protective device for the unit shall be fuse or HACR breaker. Canadian units may be fuse or circuit breaker.

2. Unbalanced 3-Phase Supply Voltage

Never operate a motor where a phase imbalance in supply voltage is greater than 2%. Use the following formula to determine the percentage of voltage imbalance.

$$\% \text{ Voltage Imbalance} = 100 \times \frac{\text{max voltage deviation from average voltage}}{\text{average voltage}}$$

Example: Supply voltage is 230-3-60



AB = 224 v
BC = 231 v
AC = 226 v

$$\begin{aligned} \text{Average Voltage} &= \frac{(224 + 231 + 226)}{3} = \frac{681}{3} \\ &= 227 \end{aligned}$$

Determine maximum deviation from average voltage.

$$(AB) 227 - 224 = 3 \text{ v}$$

$$(BC) 231 - 227 = 4 \text{ v}$$

$$(AC) 227 - 226 = 1 \text{ v}$$

Maximum deviation is 4 v.

Determine percent of voltage imbalance.

$$\begin{aligned} \% \text{ Voltage Imbalance} &= 100 \times \frac{4}{227} \\ &= 1.76\% \end{aligned}$$

This amount of phase imbalance is satisfactory as it is below the maximum allowable 2%.

IMPORTANT: If the supply voltage phase imbalance is more than 2%, contact your local electric utility company immediately.

APPENDIX D — I/O FLEX 6126 CONTROLLER

General

This appendix details the installation and configuration of the I/O Flex 6126 into the Building Automation System (BAS).

The I/O Flex 6126 is a general purpose controller. It provides the communications circuitry, non-volatile

memory, and removable screw terminals for I/O connections.

The I/O Flex 6126 controller is factory-mounted in the 48/50HC unit's main control box, to the left of the CTB (central terminal board). See Figs. 31 and 32 for location of the I/O Flex 6126 control.

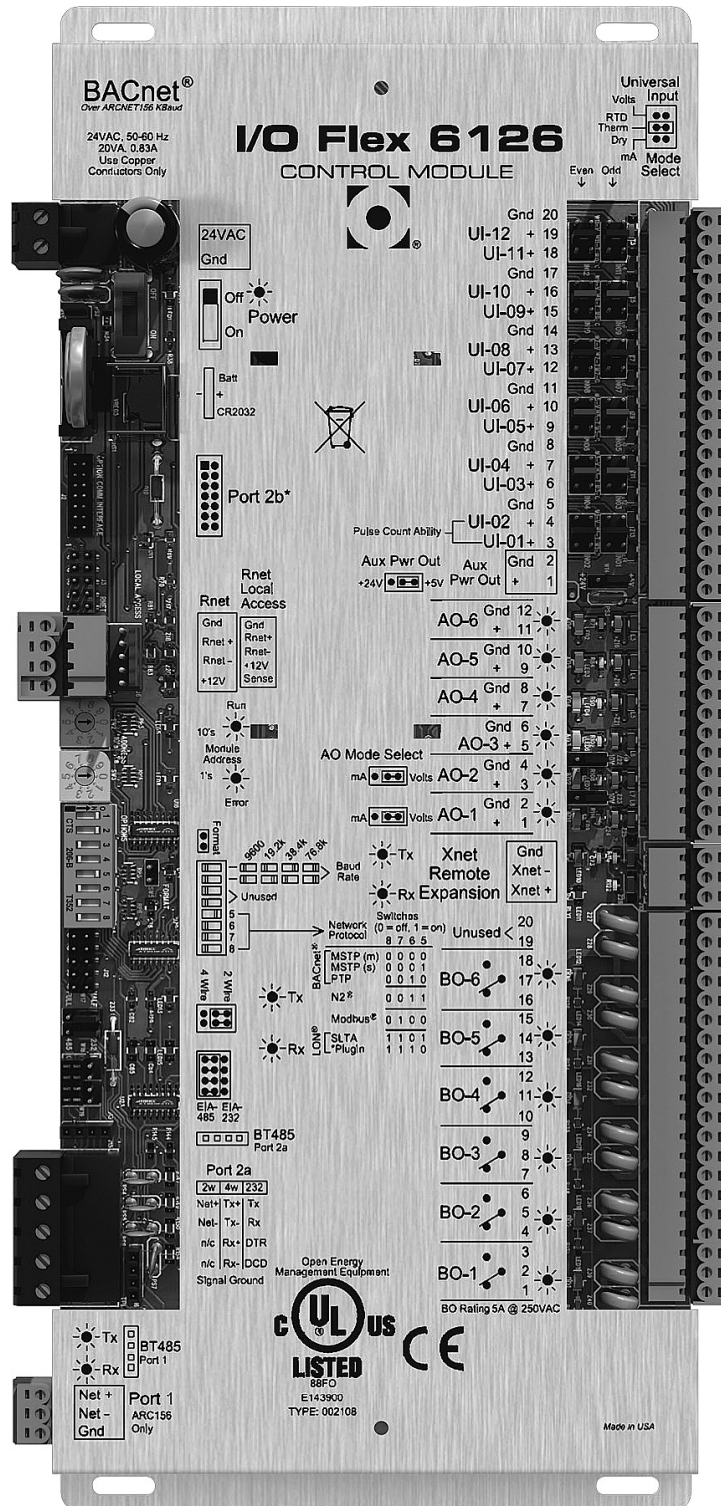
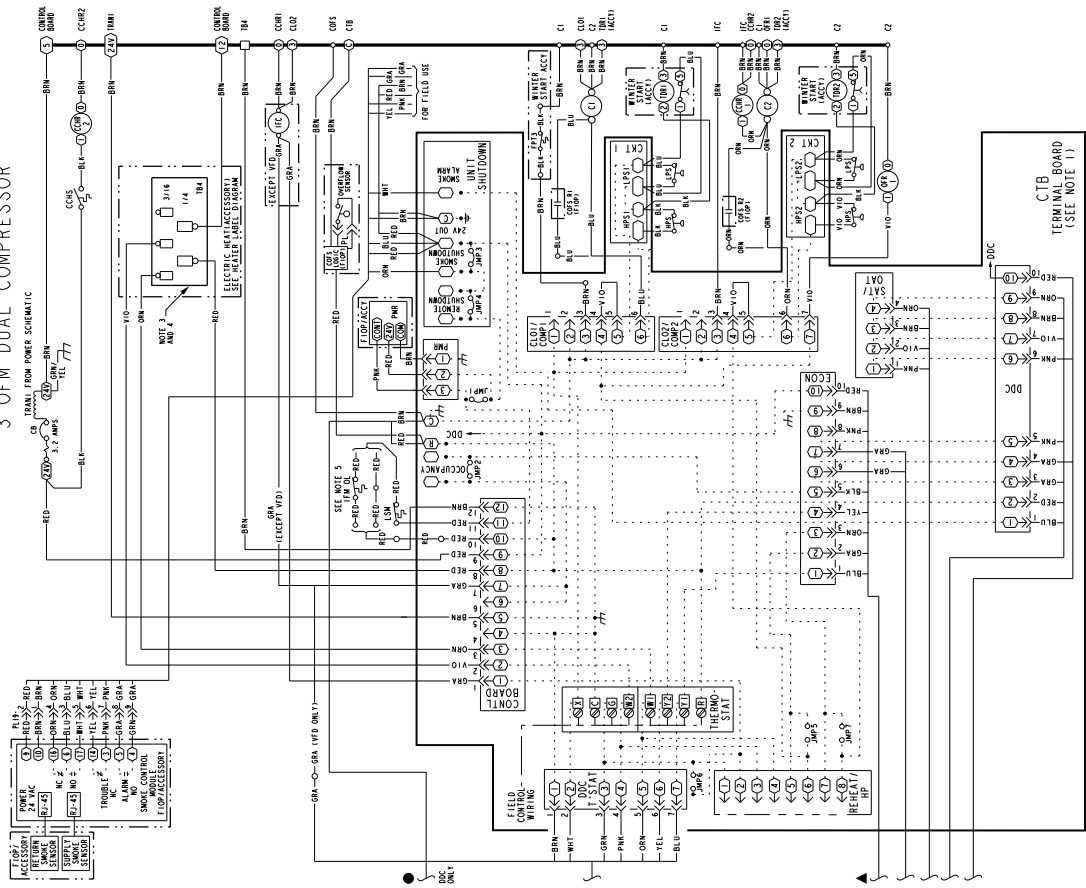

Fig. 30 - I/O Flex 6126 Controller

Specifications

Driver	drv_ioflex
Maximum number of control programs*	20
Maximum Number of BACnet objects*	1000
* Depends on available memory	
Power	24 Vac \pm 10%, 50–60 Hz 20 VA power consumption (26 VA with BACview attached) 26 Vdc (25 V min, 30 V max) Single Class 2 source only, 100 VA or less
Comm Ports	Port 1: For communication with ARC156 networks Port 2a: For communication on EIA–232 or EIA–485 (2–wire or 4–wire). Network protocol selectable for: <ul style="list-style-type: none"> • BACnet (MS/TP or PTP) • Modbus • N2 • LonWorks SLTA Port 2b: For LonWorks Option Card
Rnet port	For connecting to RS sensors and/or BACview. Supports any of the following: <ul style="list-style-type: none"> • 1 RS Plus, RS Pro, or RS Pro–F • 1–4 RS Standards • 1–4 RS Standards, and 1 RS Plus, RS Pro, or RS Pro–F Any of the above combinations, plus up to 2 BACview, but no more than 6 devices total.
Local Access port	For local communication with a laptop computer running WebCTRL or for communications with a BACview ⁶ .
Universal inputs	12 inputs configurable for 0–10 V, RTD Therm Dry, or 0–20mA. Inputs 1 and 2 may be used for pulse counting.
Input pulse frequency	Maximum of 10 pulses per second. Minimum pulse width required for each pulse: <ul style="list-style-type: none"> • ON to OFF time (half cycle) is 50 msec • ON to OFF to ON time (full cycle) is 100 msec
Input resolution	12 bit A/D
Binary outputs	6 binary outputs, relay contacts rated at 5A max @ 250 Vac. Configured normally open or normally closed.
Analog outputs	6 analog outputs, Inputs 1 and 2 are configurable for 0–10 V or 0–20mA, 3 – 6 are 0–10 V only.
Output resolution	8 bit D/A
Memory	1 MB non-volatile battery-backed RAM, 1 MB Flash memory, 16-bit memory bus
Real–time clock	Battery–backed real–time clock keeps track of time in event of power failure
Battery	10-year Lithium CR2032 battery provides a minimum of 10,000 hours of data retention during power outages
Protection	Incoming power and network connections – non-replaceable internal solid-state polswitches reset themselves when fault clears Power, network, I/O connections – protected against voltage transient and surge events
Status indicators	LEDs indicate status of communications, running, errors, and power. LED indicators for transmit/receive for Port 1 and Port 2a and for each of the 12 outputs.
Environmental operating range	–20° to 140°F (–29° to 60°C), 10–95% relative humidity, non-condensing
Physical	Rugged aluminum housing with removable screw terminals
Overall dimensions (H x W x D)	11 ¹³ / ₁₆ in. (30 cm) x 5 in. (12.7 cm) x 1 ⁹ / ₁₆ in. (4 cm)
Weight	1.1 lb. (0.5 kg)
BACnet Support	Conforms to Advanced Applications Controller (B–AAC) Standard Device Profile as defined in ANSI/ASHRAE Standard 135–2004 (BACnet) Annex L
Listed by	UL916 (Canadian Std C22.2 No. 205–m1983, CE, FCC Part 15 – Subpart B – Class A

PAC CONTROL 208/230V, 460V, 575V
3 OFM DUAL COMPRESSOR



50TM5010641 G

50TM5010641 G

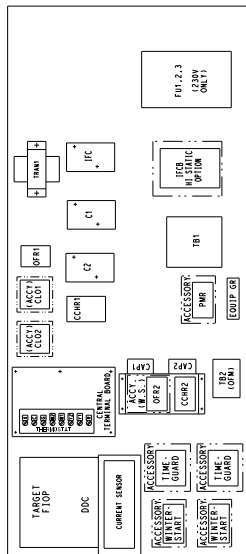

- NOTES:
1. TERMINAL BOARD SCHEMATIC LAYOUT DOES NOT MATCH ACTUAL TERMINAL BOARD. TO SIMPLIFY CIRCUIT TRACES.
 2. ENSURE DESIGNATED JUMPERS ON TERMINAL BOARD ARE CUT WHEN ADDING SMOKE CONTROL, OCCUPANCY, AND REMOTE SHUTDOWN.
 3. TBA IS LOCATED IN HEAT SECTION.
 4. FOR HEATERS WITH TWO STAGES, CONNECT VIOLET HEATER WIRE TO TBA ORANGE WIRE - SEE HEATER LABEL DIAGRAM.

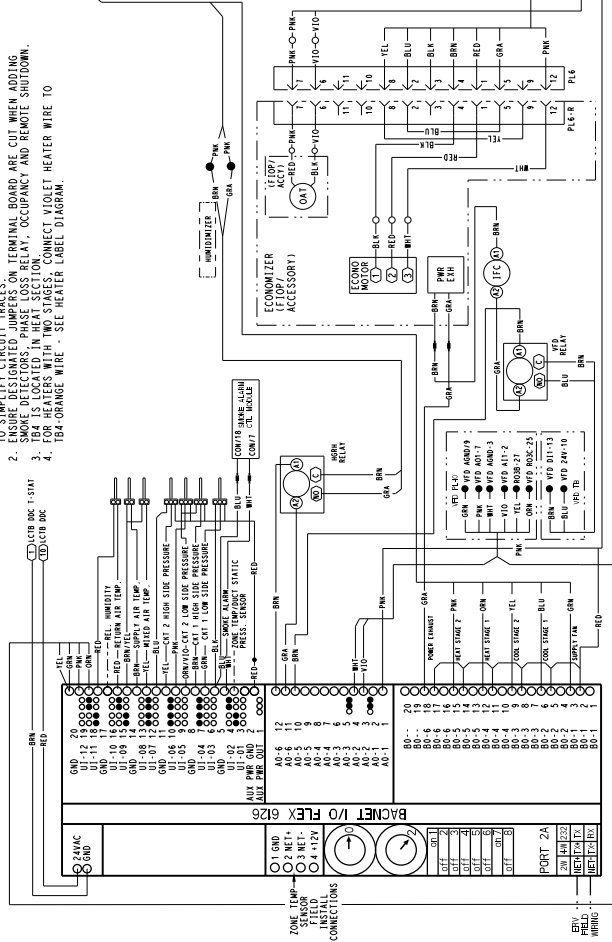

NOTE: Economizer not available for Target units equipped with ERV
Fig. 32 - Wiring Diagram - 50HC*14 with I/O Flex 6126 Controller

To Address the I/O Flex 6126 —

The I/O Flex 6126's two rotary switches determine the I/O Flex 6126's MAC address when it is placed on the BACnet/ARC156 or BACnet MS/TP network. The rotary switches define the MAC address portion of the device's BACnet address, which is composed of the network address and the MAC address. They also set the slave address on a Modbus or N2 network, when less than 100.

1. If the I/O Flex 6126 has been wired for power, pull the screw terminal connector from its power terminals labeled **Gnd** and **Hot**. The controller reads the address each time you apply power to it.
2. Using the rotary switches, set the controller's address. Set the **Tens (10's)** switch to the tens digit of the address, and set the **Ones (1's)** switch to the ones digit.

EXAMPLE: If the controller's address is 25, point the arrow on the **Tens (10's)** switch to 2 and the arrow on the **Ones (1's)** switch to 5. See the figure below

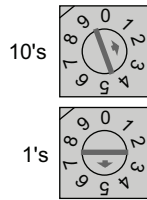

C12790

NOTE: The I/O Flex 6126 recognizes its address only after power has been cycled.

Wiring Inputs and Outputs

Input Wiring Specifications

Input	Maximum Length	Minimum Gauge	Shielding
0–5 Vdc	1000 feet (305 meters)	26 AWG	Shielded
0–20 mA	3000 feet (914 meters)	26 AWG	Shielded or Unshielded
Thermistor Dry Contact Pulse Counter TLO	1000 feet (305 meters)	22 AWG	Shielded
RTD	100 feet (30 meters)	22 AWG	Shielded
RS Sensor	500 feet (152 meters)	19 AWG, 4 conductor if a BACview is connected to the Rnet 22 AWG, 4 conductor if only RS room sensors are connected	Shielded or Unshielded

Inputs

The I/O Flex 6126 has 12 inputs that accept the signal types described below.

These Inputs...	Support this signal type...	Description
All	Thermistor RTD 0–20 mA 0–10 Vdc	Precon type 2 (10 kOhm at 77F). Input voltages should be from 0.489 Vdc to 3.825 Vdc for thermistors. The input impedance of the I/O Flex 6126 is approximately 1 Mohm.
All	Dry Contact	A 5 Vdc wetting voltage detects contact position, resulting in a 0.5 mA maximum sense current when the contacts are closed.
UI–1, UI–2	Pulse Input	Maximum of 10 pulses per second. Minimum pulse width required for each pulse: <ul style="list-style-type: none"> • ON to OFF time (half cycle) is 50 msec • ON to OFF to ON time (full cycle) is 100 msec

To Wire for Power —

⚠ CAUTION

EQUIPMENT PERFORMANCE HAZARD

Failure to follow this caution may cause equipment to not work properly.

- The I/O Flex 6126 has an operating range of 21.6 Vac to 26.4 Vac. If voltage measured at the I/O Flex 6126's input terminals is outside of this range, the I/O Flex 6126 may not work properly.
- Do not power pilot relays from the same transformer that powers the I/O Flex 6126.

1. Turn off the I/O Flex 6126's power to prevent it from powering up before you can verify the correct voltage.
2. Remove power from the 24 Vac transformer
3. Pull the screw terminal connector from the controller's power terminals labeled Gnd and 24 Vac.
4. Connect the transformer wires to the screw terminal connector.
5. Apply power to the transformer.
6. Measure the voltage at the I/O Flex 6126's power input terminals to verify that the voltage is within the operating range of 21.6 - 26.4 Vac.
7. Insert the screw terminal connector into the I/O Flex 6126's power terminals.
8. Turn on the I/O Flex 6126's power.
9. Verify that the Power LED is on and the Run LED is blinking.

Local Access

To Communicate Through the Local Access Port

Use a computer and a USB Link Kit to communicate locally with the I/O Flex 6126 to download or to troubleshoot.

Prerequisites

- A computer with a USB port
- A USB Link Kit

⚠ CAUTION

EQUIPMENT DAMAGE HAZARD

Failure to follow this caution may cause equipment damage.

- Failure to maintain polarity while using the USB Link on a computer that is grounded via its AC adapter may damage the USB Link and the I/O Flex 6126 controller.
- If wary of the integrity of electrical work, and the computer is running on AC power use a USB isolator (secured through a third-party manufacturer). First plug the USB isolator into the computer's USB port, then connect the USB Link to the isolator.

EnergyX

1. If using the USB Link Kit with your computer for the first time, install the USB Link Kit's driver before connecting the cable to the computer.
 - a. Put the USB Link Driver CD or WebCTRL install DVD into the computer.
 - b. Install the USB Link Driver, accepting all of the wizard's default settings.
2. Connect the USB Link Kit to the computer and to the I/O Flex 6126 controller's Local Access port.

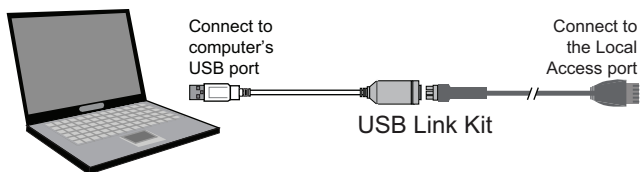

C12795

Rnet Wiring Specifications

NOTE: Use the specified type of wire and cable for maximum signal integrity.

Description	4 conductor, shielded or unshielded, CMP, plenum rated cable
Conductor	22 AWG (7x0096) bare copper if Rnet has only RS sensors. 18 AWG (7x0152) bare copper if Rnet has a BACview.
Maximum length	500 feet (152 meters)
Insulation	Low-smoke PVC (or equivalent)
Color Code	Black, White, Green, Red
Shielding	If shielded, Aluminum/Mylar shield (100% coverage) with TC drain wire
UL temperature rating	32–167°F (0–75°C)
Voltage	300 Vac, power limited
Listing	UL: NEC CL2P, or better

Wiring an RS Room Sensor to the I/O Flex 6126

The I/O Flex 6126 supports up to 5 RS sensors on its BACview/RS sensor port.

RS sensors can be wired to the I/O Flex 6126's Rnet port in any of the following combinations:

- 1 RS Plus, RS Prow, or RS Pro-F
 - 1–4 RS Standards
 - 1–4 RS Standards, and 1 RS Plus, RS Pro*, or RS Pro-F
- * The RS Pro is a thermistor-based temperature sensor.

To Wire an RS Room Sensor —

1. Turn off the I/O Flex 6126's power.
2. Pull the screw terminal connector from the RS sensor.
3. Pull the screw terminal connector from the Rnet port.
4. Partially cut, then bend and pull off the outer jacket of the Rnet cable(s). Do not nick the inner insulation.

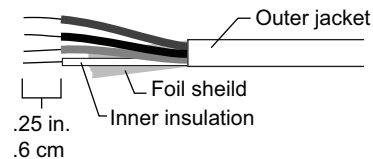

C12796

5. Strip about .25 inch (.6 cm) of the inner insulation from each wire.
6. Wire each terminal on the I/O Flex 6126's Rnet port to the terminal of the same name on the RS room sensor.

NOTES:

- If using shielded wire, connect the shield wire and the ground wire to the Gnd terminal.
- Maintain same polarity.

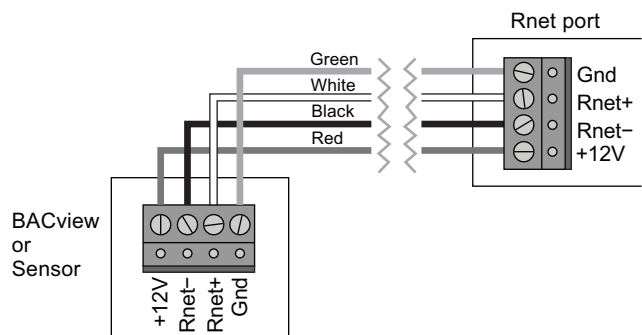

C12797

7. Turn on the I/O Flex 6126's power.

Troubleshooting

If you have problems wiring or addressing the I/O Flex 6126, contact OEMCtrl Technical Support.

Communication LED's

The LED's indicate if the I/O Flex 6126 controller is speaking to the devices on the network. The LED's should reflect communication traffic based on the baud rate set. The higher the baud rate the more solid the LED's become.

LED	Status
	Lights when power is being supplied to the controller. NOTE: The I/O Flex 6126 is protected by internal solid state Polyswitches on the incoming power and network connections. These Polyswitches are not replaceable and will reset themselves if the condition that caused the fault returns to normal.
Rx	Lights when the controller receives data from the network segment; there is a Rx LED for Ports 1 and 2.
Tx	Lights when the controller transmits data to the network segment; there is a Tx LED for Ports 1 and 2.
Run	Lights based on the controllers health. See table below.
Error	Lights based on the controllers health. See table below.

The **Run** and **Error** LED's indicate controller and network status.

If Run LED shows...	And Error LED shows...	Status is...
1 flash per second	1 flash per second, alternating with the Run LED	The controller files are archiving. Archive is complete when Error LED stops flashing
2 flashes per second	Off	Normal
2 flashes per second	2 flashes, alternating with Run LED	Five minute auto-restart delay after system error
2 flashes per second	3 flashes, then off	The controller has just been formatted
2 flashes per second	On	Two or more devices on this network have the same MS/TP network address
2 flashes per second	1 flash per second	The controller is alone on the network
2 flashes per second	On	Exec halted after frequent system errors, due to: <ul style="list-style-type: none"> • Controller halted • Program memory corrupted • Address conflicts – duplicate MS/TP MAC addresses • One or more programs stopped
5 flashes per second	On	Exec start-up aborted, Boot is running
5 flashes per second	Off	Firmware transfer in progress, Boot is running
7 flashes per second	7 flashes per second, alternating with Run LED	Ten second recovery period after brownout
14 flashes per second	14 flashes per second, alternating with Run LED	Brownout
On	On	Failure, Try the following solutions: <ul style="list-style-type: none"> • Turn the I/O Flex 6126 off, then on. • Download memory to the I/O Flex 6126. • Replace the I/O Flex 6126.

Serial Number

If you need the I/O Flex 6126's serial number when troubleshooting, the number is on :

- a sticker on the back of the I/O Flex controller board
- a Module Status report (modstat) from WebCTRL

Compliance

FCC Compliance

This equipment has been tested and found to comply with the limits for a Class A digital device, pursuant to Part 15 of the FCC Rules. These limits are designed to provide reasonable protection against harmful interference when the equipment is operated in a commercial environment. This equipment generates, uses, and can radiate radio frequency energy and, if not installed and used in accordance with the instruction manual, may cause harmful interference to radio communications. Operation of this equipment in a residential area is likely to cause harmful interference in which case the user will be required to correct the interference at his own expense.

EnergyX

CAUTION

EQUIPMENT OPERATION HAZARD

Failure to follow this caution can result voiding the user's authority to operate the equipment.

Changes or modifications not expressly approved by the responsible party for compliance could void the user's authority to operate the equipment.

CE Compliance

WARNING

RADIO INTERFERENCE HAZARD

Failure to follow this warning could result in radio interference near by equipment.

This is a Class A product. In a domestic environment, this product may cause radio interference in which case the user may be required to take adequate measures.

BACnet Compliance

BACnet[®] is a registered trademark of ASHRAE. ASHRAE does not endorse, approve or test products for compliance with ASHRAE standards. Compliance of listed products to requirements of ASHRAE Standard 135 is the responsibility of the BACnet manufacturers Association (BMA). BTL[®] is a registered trademark of the BMA.

APPENDIX E — CARRIER BACview / VIRTUAL BACview COMMISSIONING

This appendix shows screen captures from the Virtual BACview software, however the procedure is the same regardless of which method of connection is utilized.

If you are using the handheld BACview 6, simply plug in the brown R-net connector at the end of the cable to the “Rnet Local Access” port on the I/O Flex 6126. The connector is keyed and polarity sensitive. It should fit in only one way.

If you are using the Virtual BACview Software with the USB-K connection cable, use the 4-pin adapter and not the round barrel connector. After you’ve installed the software, plug the cable into any USB port on your laptop and after the adapter has been detected and installed, go to the device manager to make a note of the COM port number the USB adapter got mapped to. Fig. 33 shows an example of this screen and in this case the COM port is COM 6.

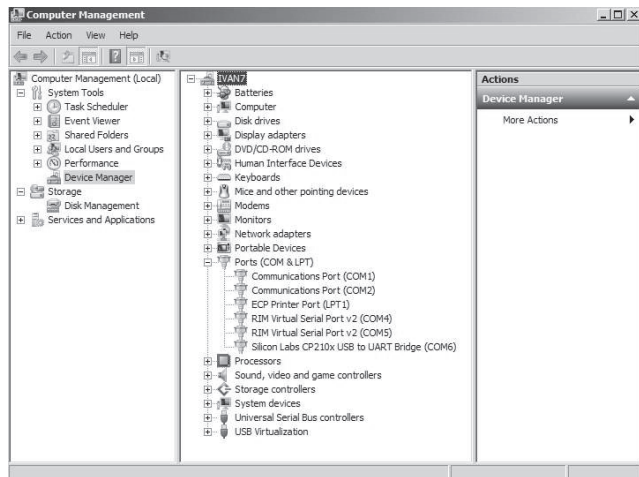

Fig. 33 - COM Port Used Example

C12798

After you’ve made a note of the COM port number, launch the Virtual BACview software. Fig. 34 shows the initial screen.

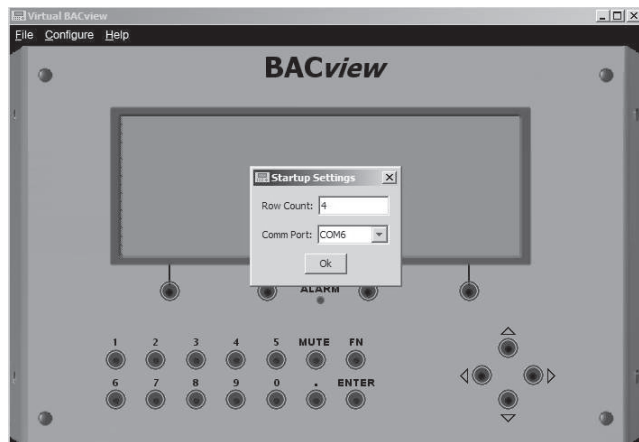

Fig. 34 - Virtual BACview Connection - Startup Settings

C12799

If you want to simulate the handheld BACview performance, leave the Row Count value set to 4 as that is the number of lines on the handheld BACview screen. It is recommended that you increase this number as it will make the navigation a bit easier.

Select the appropriate COM port number from the previous step in the pull down window and click OK.

From this point on, the directions for the Handheld BACview and the Virtual BACview Software are the same.

Upon initial connection, BACview displays the message shown in Fig. 35.

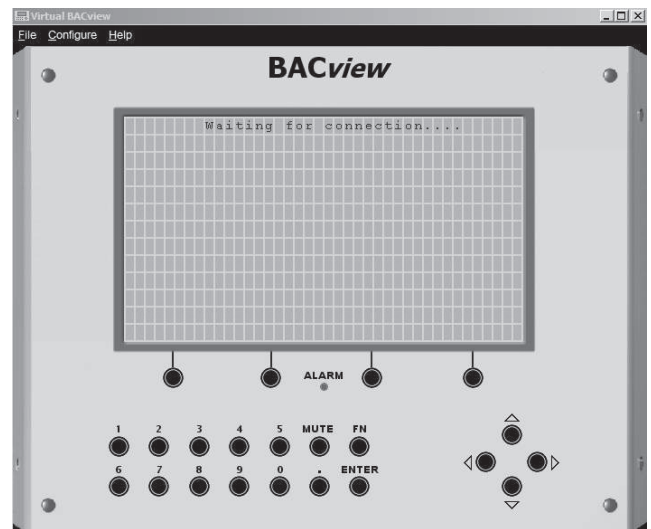

Fig. 35 - Waiting for Connection

C12800

After a few seconds the Stand By screen, as seen in Fig. 36, appears.

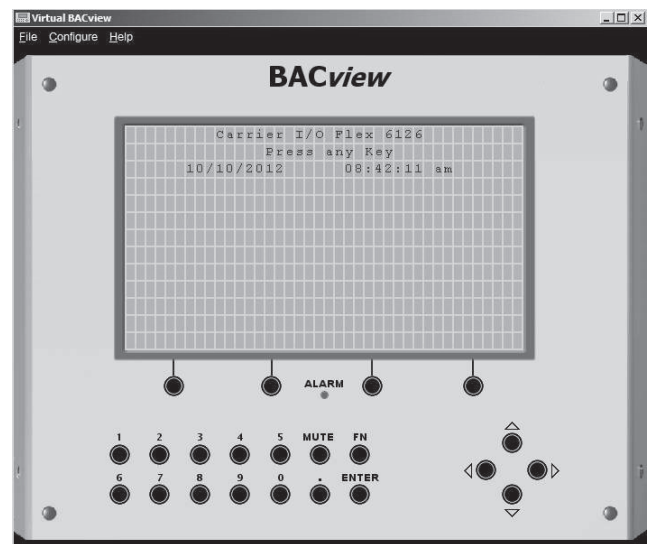
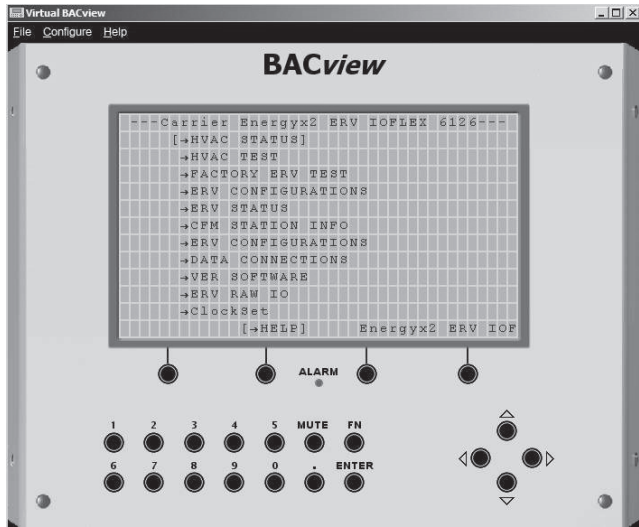

Fig. 36 - BACview Stand By Screen

C12801

Press any key and you will see the HOME screen as pictured in Fig. 37.



C12802

Fig. 37 - Home Screen with Main Menu Displayed

Using the arrow keys you can navigate up and down this selection list.

To see the current values of sensor readings and output states of the main RTU select HVAC STATUS.

To put the RTU into a TEST mode and exercise the outputs, select HVAC TEST.

To put the ERV into a TEST mode and exercise the outputs, select FACTORY ERV TEST.

The rest of the options are additional status screens which you may select if interested.

To view the HVAC Status, select HVAC STATUS; the screen in Fig. 38 appears.

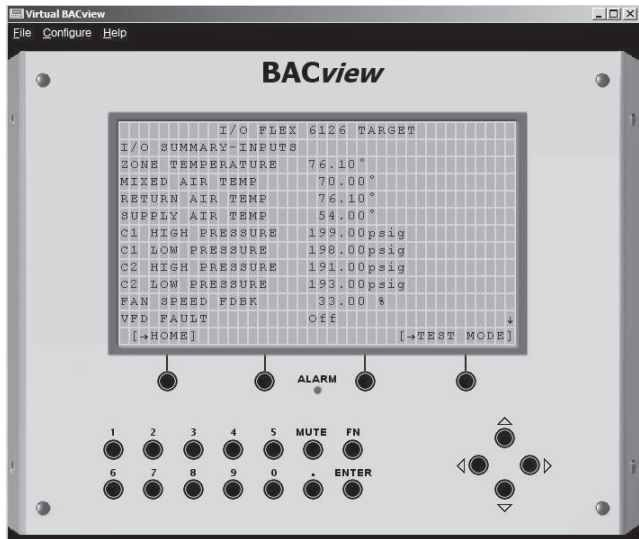

C12803

Fig. 38 - HVAC Status Screen

You can scroll down the list to see all input and output statuses.

Select HOME to go back to the main menu or TEST MODE to go to HVAC TEST.

If you pick TEST MODE, the screen shown in Fig. 39 appears.

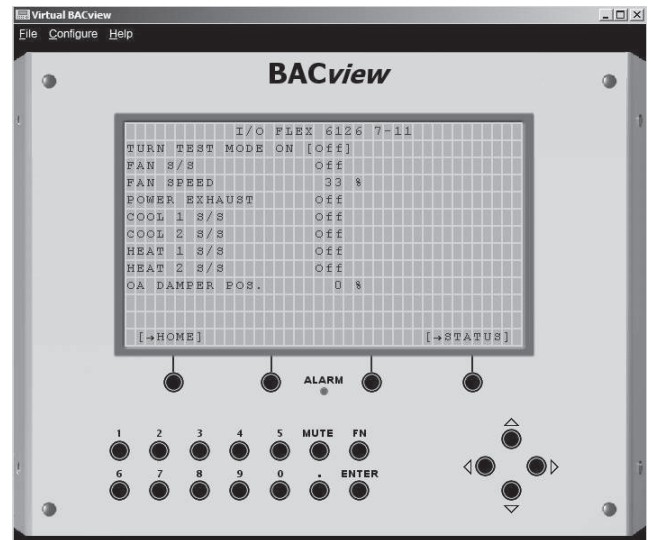

C12804

Fig. 39 - HVAC Test - Initial Screen

To start the test, place the cursor on the TURN TEST MODE ON, and press ENTER. The screen shown in Fig. 40 appears.

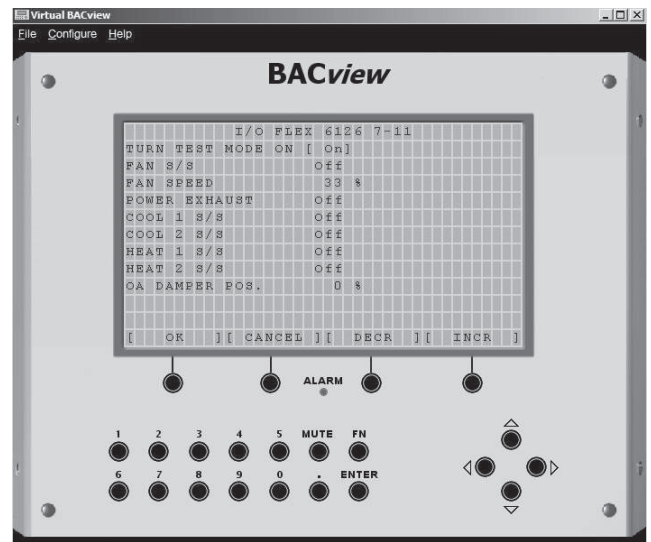

C12805

Fig. 40 - HVAC Test - Test Mode On

The function keys below the screen give you the option to OK the change, CANCEL, DECREMENT or INCREMENT the value. To turn the TEST MODE ON, Increment the value by 1, (change from OFF to ON) and press ENTER. The RTU will go into TEST MODE and the outputs of the I/O Flex 6126 will reflect the values seen on the screen. As Fig. 41 shows, you can scroll up and down and make additional changes to the output states in order to test them.

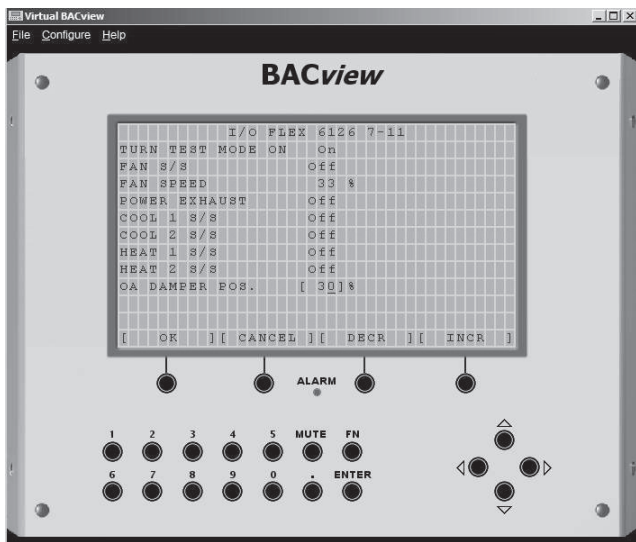

C12806

Fig. 41 - Value Changed (OA DAMPER POS)

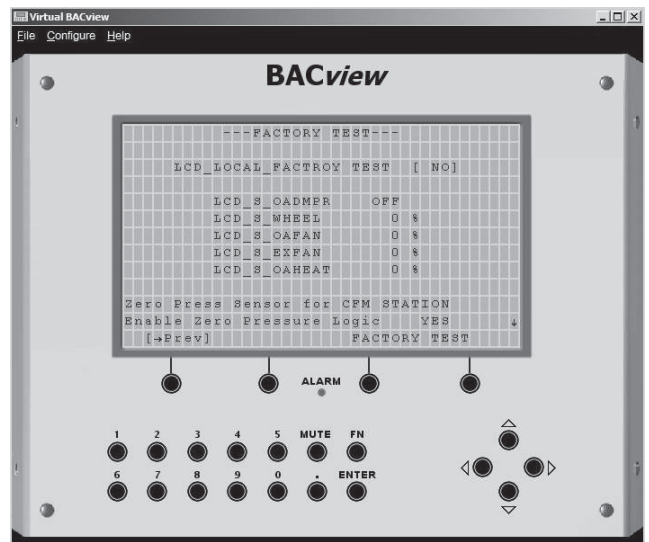

C12808

Fig. 43 - Initial ERV Test Screen

When you are done testing the outputs, change the TURN TEST MODE ON variable to OFF and click ENTER to turn off the test mode and put the RTU in AUTO mode (see Fig. 42).

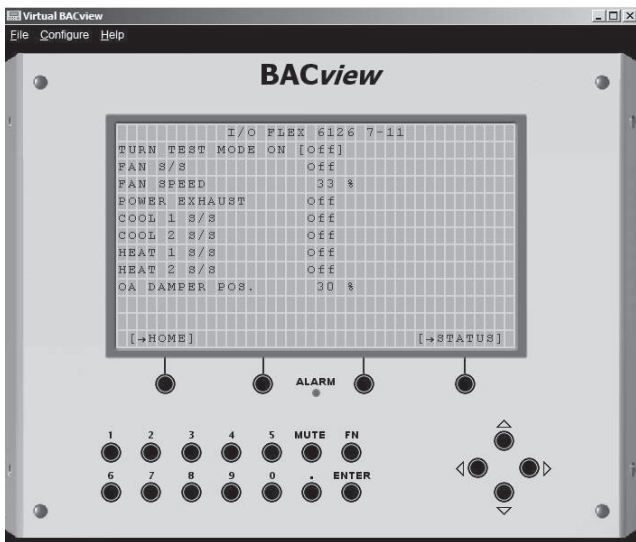

C12807

Fig. 42 - HVAC Test Completed

To run the ERV Test, from the Home screen (see Fig. 37) select FACTORY ERV TEST and then press ENTER. The screen shown in Fig. 43 appears.

To start the test, select and change LCD_LOCAL_FACTORY_TEST variable to YES (see Fig.44).

After this, you can change the values for any of the ERV outputs, thus controlling the Wheel operation as well as the speed of the OA and EX fans (see Fig. 45).

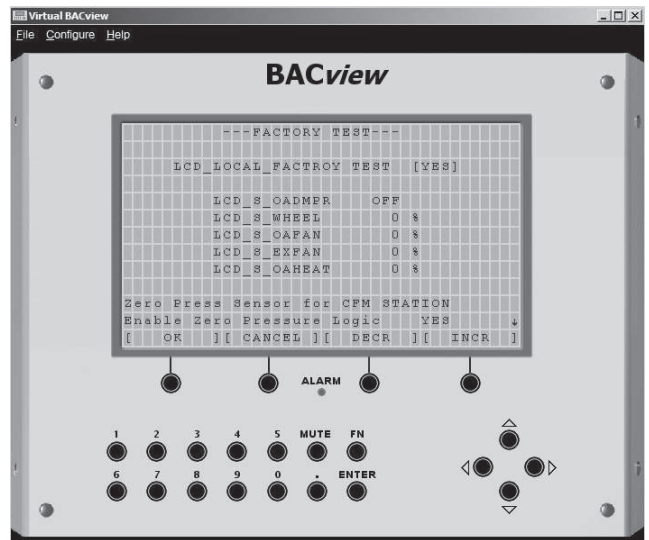

C12809

Fig. 44 - LCD_LOCAL_FACTORY_TEST set to YES

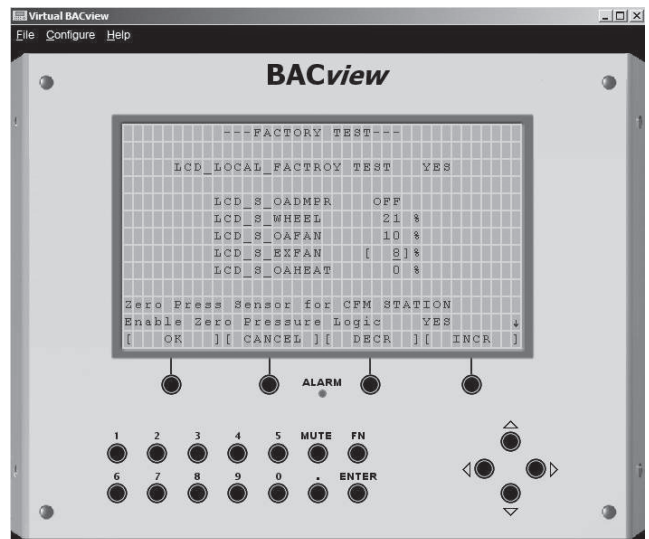

C12810

Fig. 45 - ERV Output Values Entered

To see the effect on the CFM readings your test values are having, scroll down the screen and look at the current Flow readings (see Fig. 46).

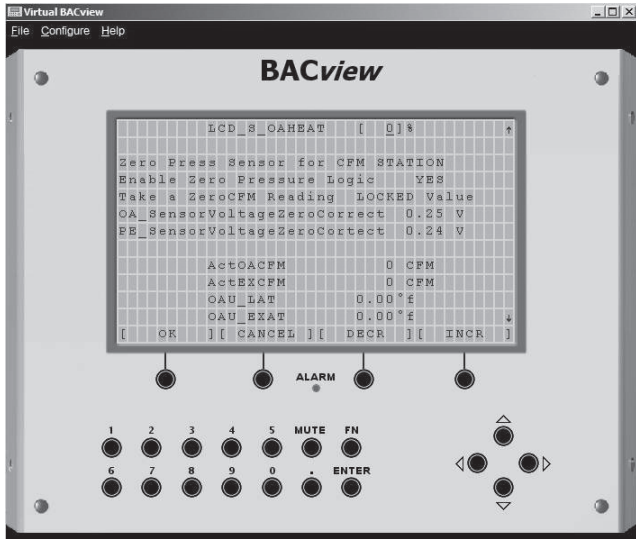

Fig. 46 - Scroll Down to View CFM Readings

After completing the ERV test, it is important to reset all values to the defaults and to turn off the test mode. If you do not turn off the test mode, the ERV will not operate properly.

Turn off the TEST mode on the top of the ERV TEST screen by setting LCD_LOCAL_FACTORY_TEST to NO (see Fig. 47).

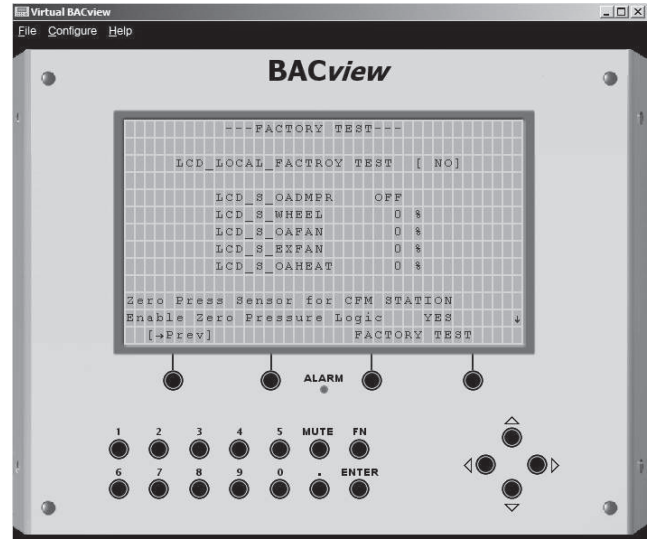

Fig. 47 - ERV Test Mode OFF

At this point you can simply disconnect from the I/O Flex 6126 and the RTU will continue operating in AUTO mode.

EnergyX

ENERGYX UNIT START-UP CHECKLIST

(To be used in conjunction with base Rooftop Unit Start-Up Checklist. Remove and Store in Job File)

RTU MODEL NO.: _____ RTU SERIAL NO.: _____
 ERV MODEL NO.: _____ ERV SERIAL NO.: _____
 DATE: _____ TECHNICIAN: _____

I. PRE-START-UP (insert checkmark in box as each item is completed)

- VERIFY THAT ALL PACKAGING MATERIALS HAVE BEEN REMOVED FROM UNIT
- VERIFY INSTALLATION OF OUTDOOR AIR HOODS
- CHECK THAT AIR FILTERS ARE CLEAN AND IN PLACE ON SUPPLY AND EXHAUST OF ERV WHEEL
- CHECK THAT OUTDOOR AIR INLET SCREENS ARE IN PLACE
- VERIFY CONFIGURAITON VALUES FOR ELECTRONIC CONTROLS

II. START-UP (REFER TO UNIT SERVICE/MAINTENANCE MANUAL FOR START-UP INSTRUCTIONS)

ELECTRICAL

SUPPLY VOLTAGE*	L1-L2 _____	L2-L3 _____	L3-L1 _____
ERV SUPPLY FAN-1 AMPS	L1-L2 _____	L2-L3 _____	L3-L1 _____
ERV EXHAUST FAN-1 AMPS	L1-L2 _____	L2-L3 _____	L3-L1 _____

*Distribution Block on 575v units will be 230v or 460v

TEMPERATURES

OUTDOOR-AIR TEMPERATURE (OAT) _____ F dB (Dry Bulb)
 RETURN-AIR TEMPERATURE (SPT or RAT) _____ F dB/F wB (Dry Bulb/Wet Bulb)
 ERV INTAKE LEAVING AIR TEMPERATURE (LAT) _____ F
 ERV EXHAUST AIR TEMPERATURE (EXAT) _____ F

GENERAL

- MINIMUM DAMPER POSITION SET TO "0"
- ERV MINIMUM VENTILATION POSITION PER JOB REQUIREMENTS
- VERIFY ENERGY RECOVERY WHEEL IS ROTATING
- VERIFY SUPPLY AND EXHAUST BLOWER FANS ROTATING IN PROPER DIRECTION
- VERIFY ALL EXTERNAL PANELS FULLY SHUT AND LATCHED
- VERIFY NO ACTIVE ALARMS
- FOLLOW ALL ACCESSORY START-UP PROCEDURES

III. CONFIGURATION (Used in conjunction with Base Unit start-up configurations)

Minimum DCV Outside Air CFM _____
 Minimum Outside Air CFM _____
 Exhaust Air Offset CFM _____
 Building Pressure Setpoint _____
 Frost Protection Dial Setpoint _____

