

# PH4G--K

## 13.4 SEER2 Single-Packaged Heat Pump System with R-410A Refrigerant Single Phase 2-5 Nominal Tons (Sizes 24-60) Three Phase 3-5 Nominal Tons (Sizes 36-60)

### Installation Instruction

**IMPORTANT:** Effective January 1, 2023, all split system and packaged air conditioners must be installed pursuant to applicable regional efficiency standards issued by the Department of Energy.

**NOTE:** Read the entire instruction manual before starting the installation.

**NOTE:** Installer: Make sure the Owner's Manual and Service Instructions are left with the unit after installation.

#### Table of Contents

Safety Considerations	1
Introduction	2
Receiving and Installation	2
Identify Unit	2
Inspect Shipment	2
Roof Curb	2
Slab Mount	2
Inspection	7
Rigging/Lifting of Unit (See Fig. 5)	8
Configuring Units for Downflow (Vertical) Discharge	8
High-Voltage Connections	10
Special Procedures for 208-V Operation	10
Control Voltage Connections	10
Standard Connections	10
Transformer Protection	10
Accessory Electric Heaters Installation	10
Sequence of Operation	10
Pre-Start-Up	19
Start-Up	19
Checking Cooling and Heating Control Operation	19
Checking and Adjusting Refrigerant Charge	20
Indoor Airflow and Airflow Adjustments	20
Single Cooling Fan Speed Set-up (Dehumidification feature not used)	20
Two Cooling Fan Speeds Set-up (Dehumidification feature used)	20
Single Speed Cooling With Higher Electric Heat Speed	21
Continuous Fan Operation	21
Demand Defrost Mode	22
Maintenance	25
Indoor Blower and Motor	25
Refrigerant	29
Compressor Oil	29
Servicing Systems on Roofs with Synthetic Materials	29
Liquid Line Filter Drier	29
R-410A Refrigerant Charging	29
Loss of Charge Switch	30
Check Defrost Thermostat	30
Troubleshooting	30
Start-Up Checklist	30

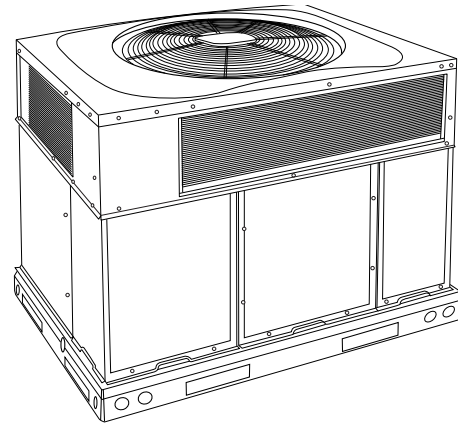

Fig. 1 – Unit PH4G

A09183

#### Safety Considerations

Installation and servicing of this equipment can be hazardous due to mechanical and electrical components. Only trained and qualified personnel should install, repair, or service this equipment.

Untrained personnel can perform basic maintenance functions such as cleaning and replacing air filters. All other operations must be performed by trained service personnel. When working on this equipment, observe precautions in the literature, on tags, and on labels attached to or shipped with the unit and other safety precautions that may apply.

Follow all safety codes. Wear safety glasses, protective clothing, and work gloves. Use quenching cloth for brazing operations. Have a fire extinguisher available. Read these instructions thoroughly and follow all warnings or cautions included in literature and attached to the unit. Consult local building codes, the current editions of the National Electrical Code (NEC) NFPA 70.

In Canada refer to the current editions of the Canadian Electrical Code CSA C22.1.

Recognize safety information. This is the safety-alert symbol . When you see this symbol on the unit and in instructions or manuals, be alert to the potential for personal injury. Understand these signal words: DANGER, WARNING, and CAUTION. These words are used with the safety-alert symbol. DANGER identifies the most serious hazards which will result in severe personal injury or death. WARNING signifies hazards which could result in personal injury or death. CAUTION is used to identify unsafe practices which may result in minor personal injury or product and property damage. NOTE is used to highlight suggestions which will result in enhanced installation, reliability, or operation.

 **WARNING**

**ELECTRICAL SHOCK HAZARD**

Failure to follow this warning could result in personal injury or death. Before installing or servicing system, always turn off main power to system and install lockout tag. There may be more than one disconnect switch. Turn off accessory heater power switch if applicable.

 **CAUTION**

**CUT HAZARD**

Failure to follow this caution may result in personal injury. When removing access panels (see Fig. 23 or performing maintenance functions) inside your unit, be aware of sharp sheet metal parts and screws. Although special care is taken to reduce sharp edges to a minimum, be extremely careful and wear appropriate clothing, safety glasses and gloves when handling parts or reaching into the unit.

 **WARNING**

**PERSONAL INJURY AND PROPERTY DAMAGE HAZARD**

For continued performance, reliability, and safety, the only approved accessories and replacement parts are those specified by the equipment manufacturer. The use of non-manufacturer approved parts and accessories could invalidate the equipment limited warranty and result in fire risk, equipment malfunction, and failure. Please review manufacturer's instructions and replacement part catalogs available from your equipment supplier.

## Introduction

This heat pump is fully self-contained and designed for outdoor installation. (See Fig. 1) Standard units are shipped in a horizontal-discharge configuration for installation on a ground level slab. Standard units can be converted to downflow (vertical) discharge configurations for rooftop applications.

 **NOTICE**

If the unit gasketing or insulation must be replaced, ensure the material used is compliant with the two agency requirements listed.

1. Insulation and adhesives shall meet NFPA 90.1 requirements for flame spread and smoke generation.
2. Cabinet insulation shall meet ASHRAE Standard 62.2.

## Receiving and Installation

### Step 1 – Check Equipment

#### Identify Unit

The unit model number and serial number are stamped on the unit identification plate. Check this information against shipping papers.

#### Inspect Shipment

Inspect for shipping damage before removing packaging material. If unit appears to be damaged or is torn loose from its anchorage, have it examined by transportation inspectors before removal. Forward claim papers directly to transportation company. Manufacturer is not responsible for any damage incurred in transit. Check all items against shipping list. Immediately notify the nearest equipment distributor if any item is missing. To prevent loss or damage, leave all parts in original packages until installation.

If the unit is to be mounted on a curb in a downflow application, review Step 5 to determine which method is to be used to remove the downflow panels before rigging and lifting into place. The panel removal process may require the unit to be on the ground.

### Step 2 – Provide Unit Support

#### Roof Curb

Install accessory roof curb in accordance with instructions shipped with curb (See Fig. 4). Install insulation, cant strips, roofing, and flashing. Ductwork must be attached to curb.

**IMPORTANT:** The gasketing of the unit to the roof curb is critical for a watertight seal. Install gasketing material supplied with the roof curb. Improperly applied gasketing also can result in air leaks and poor unit performance.

Curb should be level to within 1/4 in. (6 mm) (See Fig. 7). This is necessary for unit drain to function properly. Refer to accessory roof curb installation instructions for additional information as required.

#### Installation on older “G” series roof curbs.

Two accessory kits are available to aid in installing a new “G” series unit on an old “G” roof curb.

1. Accessory kit number CPADCURB001A00, (small chassis) and accessory kit number CPADCURB002A00, (large chassis) includes roof curb adapter and gaskets for the perimeter seal and duct openings. No additional modifications to the curb are required when using this kit.
2. An alternative to the adapter curb is to modify the existing curb by removing the outer horizontal flange and use accessory kit number CPGSKTKIT001A00 which includes spacer blocks (for easy alignment to existing curb) and gaskets for the perimeter seal and duct openings. This kit is used when existing curb is modified by removing outer horizontal flange.

 **CAUTION**

**UNIT/STRUCTURAL DAMAGE HAZARD**

Failure to follow this caution may result in property damage. Ensure there is sufficient clearance for saw blade when cutting the outer horizontal flange of the roof curb so there is no damage to the roof or flashing.

#### Slab Mount

Place the unit on a solid, level pad that is at least 2 in. (51 mm) above grade (See Fig. 8). The pad should extend approximately 2 in. (51 mm) beyond the casing on all 4 sides of the unit. Do not secure the unit to the pad except when required by local codes.

### Step 3 – Provide Clearances

The required minimum service clearances are shown in Fig. 2 and Fig. 3. Adequate ventilation and outdoor air must be provided. The outdoor fan

draws air through the outdoor coil and discharges it through the top fan grille. Be sure that the fan discharge does not recirculate to the outdoor coil. Do not locate the unit in either a corner or under an overhead obstruction. The minimum clearance under a partial overhang (such as a normal house overhang) is 48 in. (1219 mm) above the unit top. The maximum horizontal extension of a partial overhang must not exceed 48 in. (1219 mm).

**IMPORTANT:** Do not restrict outdoor airflow. An air restriction at either the outdoor-air inlet or the fan discharge may be detrimental to compressor life.

Do not place the unit where water, ice, or snow from an overhang or roof will damage or flood the unit. Do not install the unit on carpeting or other combustible materials. Slab-mounted units should be at least 2 in. (51 mm) above the highest expected water and runoff levels. Do not use unit if it has been under water.

COOLING CAPACITY	UNIT WT.		UNIT HEIGHT		CENTER OF GRAVITY IN/MM					
	LB	KG	"A"	"A"	X	Y	Z			
24	332	150.6	51-3/4	1315	20-1/2	520.7	15-3/4	384	16-5/8	422.3
30	365	165.6	51-3/4	1315	20-1/2	520.7	15-3/4	384	16-5/8	422.3

UNIT	CORNER WEIGHT LB/KG		
	"1"	"2"	"3"
24	84.8	38.5	74.9
30	93.3	42.3	82.1

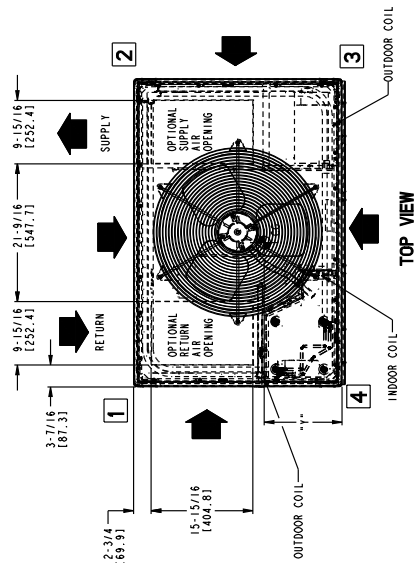

**REQUIRED CLEARANCES TO COMBUSTIBLE WALL**

TOP OF UNIT..... 2 (50.8)  
 DUCT SIDE OF UNIT..... 2 (50.8)  
 SIDE OPPOSITE DUCTS..... 14 (355.6)  
 FRONT WALL..... 6 (152.4)  
 ELECTRICAL PANEL..... 36 (914.4)

**REQ. REQUIRED CLEARANCES**

BETWEEN UNITS, POWER ENTRY SIDE..... 42 (1066.8)  
 UNIT AND UNGROUNDING SURFACES, POWER ENTRY SIDE..... 36 (914.4)  
 UNIT AND BLOCK OR CONCRETE WALLS AND OTHER GROUNDING SURFACES, POWER ENTRY SIDE..... 42 (1066.8)

**REQUIRED CLEARANCE FOR OPERATION AND SERVICE**

EVAP. COIL ACCESS SIDE..... 42 (1066.8)  
 POWER ENTRY SIDE..... 42 (1066.8)  
 (EXCEPT FOR AEC REQUIREMENTS)  
 UNIT TOP OPPOSITE DUCTS..... 48 (1219.2)  
 DUCT SIDE OPPOSITE DUCTS..... 12 (304.8)

\*MINIMUM DISTANCES: IF UNIT IS PLACED LESS THAN 12 (304.8) FROM WALL SYSTEM, THEN SYSTEM PERFORMANCE MAY BE COMPROMISED.

DIMENSIONS IN ( ) ARE IN MILLIMETERS

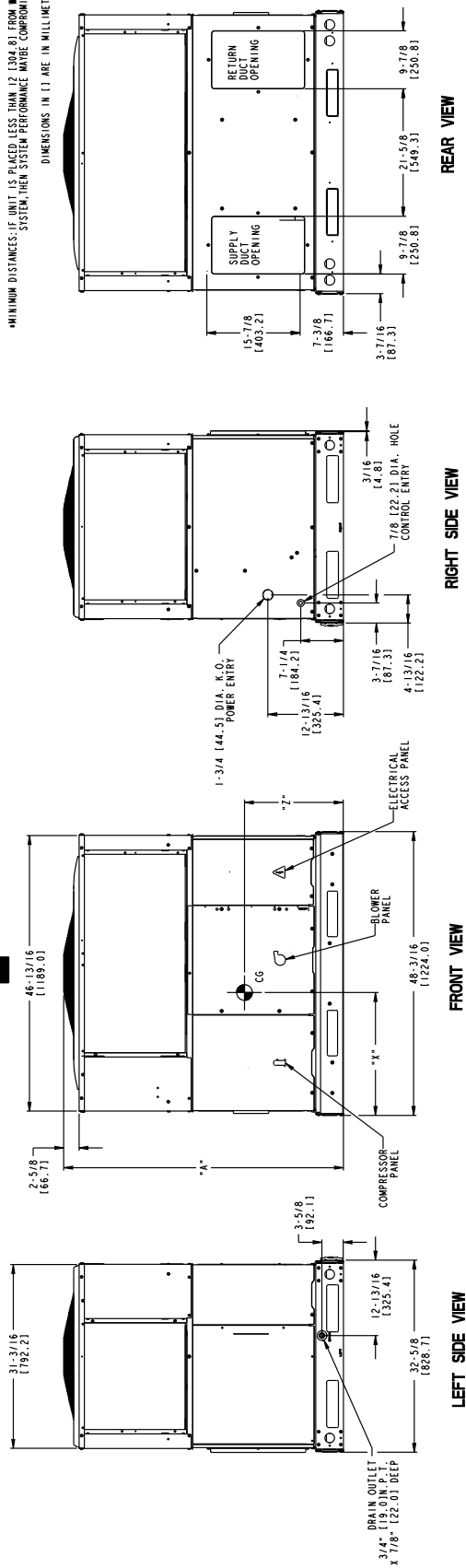

SD5772-4 A

Fig. 2 – 24-30 Unit Dimensions

COOLING CAPACITY	UNIT WT.		UNIT HEIGHT "A"	CENTER OF GRAVITY IN/MM			
	LB	KG		X	Y	Z	
36	184.2	84.3	1391	20-1/2	521	17-1/2	445
42	193.3	88.2	1391	20-1/2	521	17-1/2	445
48	193.3	88.2	1137	20-1/2	521	17-1/2	445
60	225.0	102.0	1238	20-1/2	521	17-1/2	445

UNIT	CORNER WEIGHT (B/A/C)			
	-1"	-2"	-3"	-4"
36	88.6	140.2	184.4	195.6
42	92.8	142.5	187.4	197.4
48	92.8	142.5	187.4	197.4
60	107.5	168.8	225.0	243.4

- REQUIRED CLEARANCES TO COMBUSTIBLE MITL.**
- TOP OF UNIT..... 14 [355.6]
  - SIDE OPPOSITE DUCTS..... 2 [50.8]
  - BOTTOM OF UNIT..... 0 [0.0]
  - ELECTRICAL PANEL..... 36 [914.4]
- NEC REQUIRED CLEARANCES**
- BETWEEN UNITS, POWER ENTRY SIDE..... 42 [1066.8]
  - UNIT AND UNGROUND SURFACES, POWER ENTRY SIDE..... 36 [914.0]
  - UNITS, POWER ENTRY SIDE AND OTHER GROUND SURFACES, POWER ENTRY SIDE..... 42 [1066.8]
- REQUIRED CLEARANCE FOR OPERATION AND SERVICING**
- EMP. COIL ACCESS SIDE..... 42 [1066.8]
  - POWER ENTRY SIDE..... 42 [1066.8]
  - (EXCEPT FOR NEC REQUIREMENTS)
  - TOP OF UNIT..... 48 [1219.2]
  - SIDE OPPOSITE DUCTS..... 36 [914.0]
  - DUCT PANEL..... 12 [304.8]

\*MINIMUM DISTANCES IF UNIT IS PLACED LESS THAN 12 [304.8] FROM WALL SYSTEM, THEN SYSTEM PERFORMANCE MAY BE COMPROMISED.

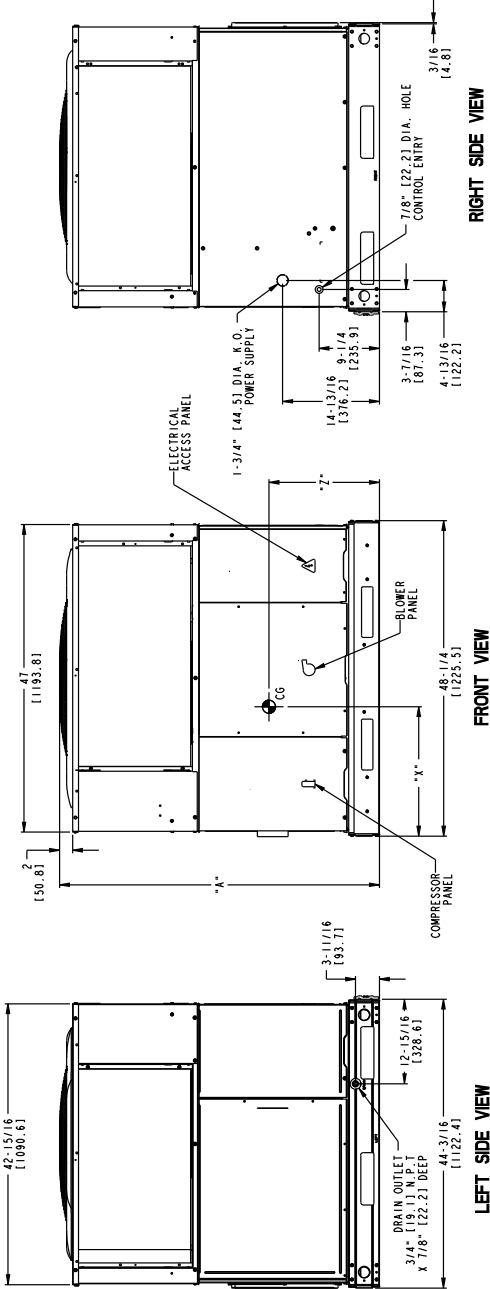
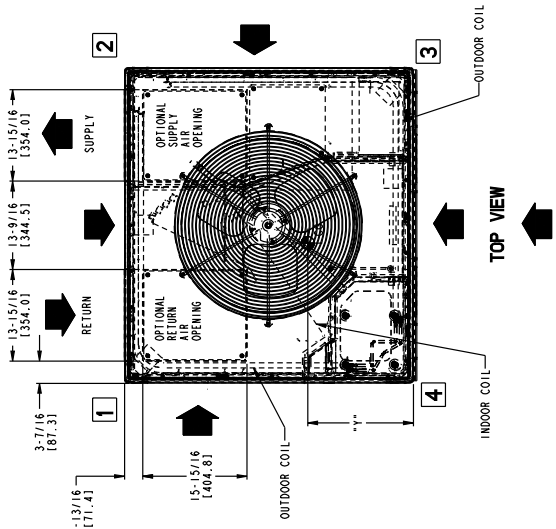

SD5772-4 A

Fig. 3 – 36-60 Unit Dimensions

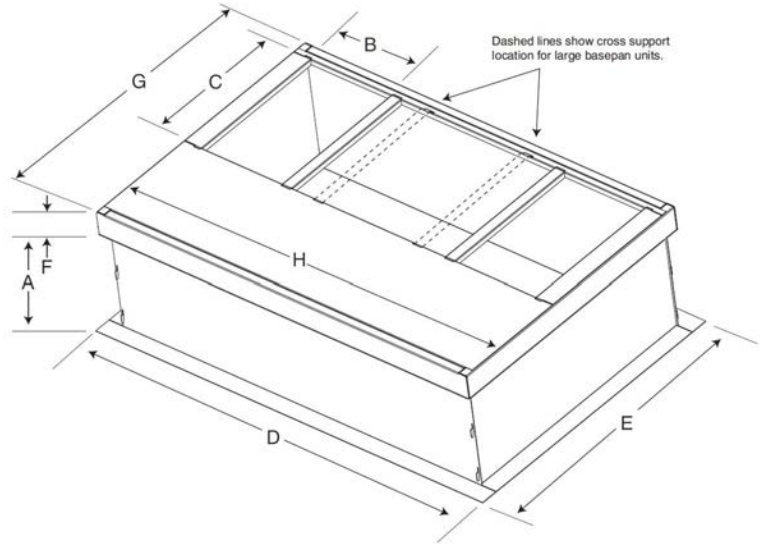
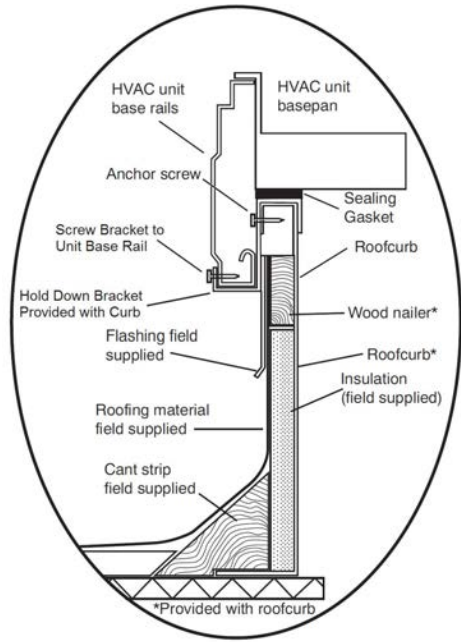

SMALL/COMMON CURB

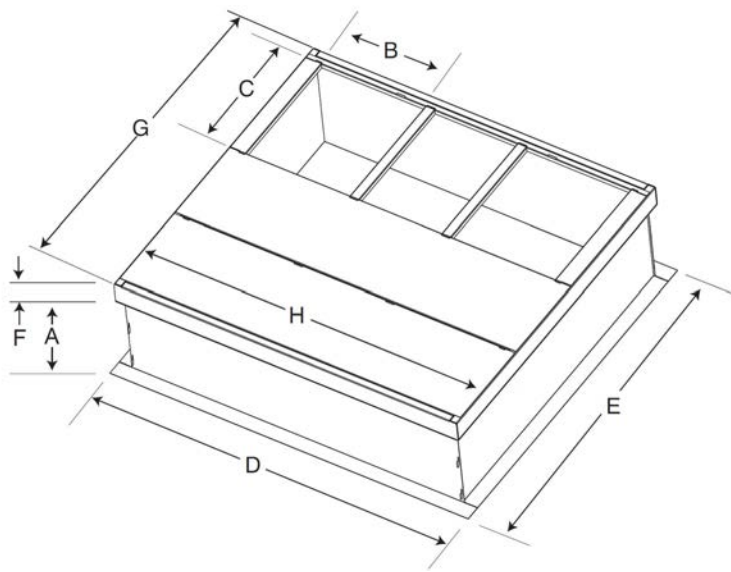

LARGE CURB

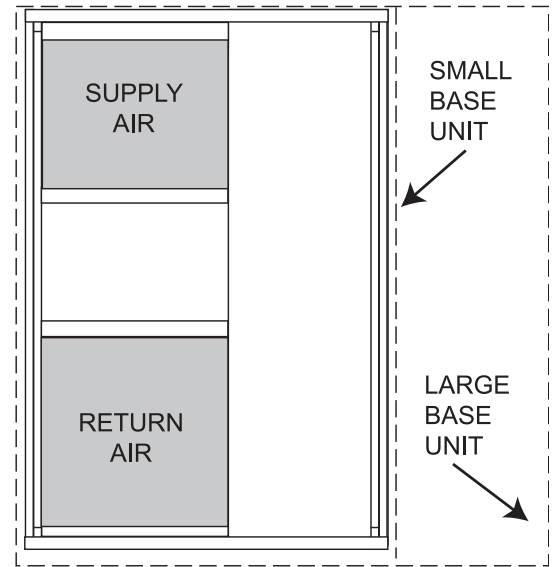

UNIT PLACEMENT ON COMMON CURB

SMALL OR LARGE BASE UNIT

Fig. 4 – Roof Curb Dimensions

A180216

UNIT SIZE	CATALOG NUMBER	A IN. (mm)	B (small/common base) IN. (mm)*	B (large base) IN. (mm)*	C IN. (mm)	D IN. (mm)	E IN. (mm)	F IN. (mm)	G IN. (mm)	H IN. (mm)
Small or Large	CPRFCURB011B00	14 (356)	10 (254)	14 (356)	16 (406)	47.8 (1214)	32.4 (822)	2.7 (69)	30.6 (778)	46.1 (1170)
Large	CPRFCURB013B00	14 (356)	14 (356)				43.9 (1116)		42.2 (1072)	

\*. Part Number CPRFCURB011B00 can be used on both small and large basepan units. The cross supports must be located based on whether the unit is a small basepan or a large basepan.

NOTES:

1. Roof curb must be set up for unit being installed.
2. Seal strip must be applied, as required, to unit being installed.
3. Roof curb is made of 16-gauge steel.
4. Attach ductwork to curb (flanges of duct rest on curb).
5. Insulated panels: 1-in. (25 mm) thick fiberglass 1 lb. density.

# ⚠ CAUTION - NOTICE TO RIGGERS ⚠ PRUDENCE - AVIS AUX MANIPULATEUR

ACCESS PANELS MUST BE IN PLACE WHEN RIGGING.  
PANNEAUX D'ACCES DOIT ÊTRE EN PLACE POUR MANIPULATION.

Use top skid as spreader bar. / Utiliser la palette du haut comme barre de répartition

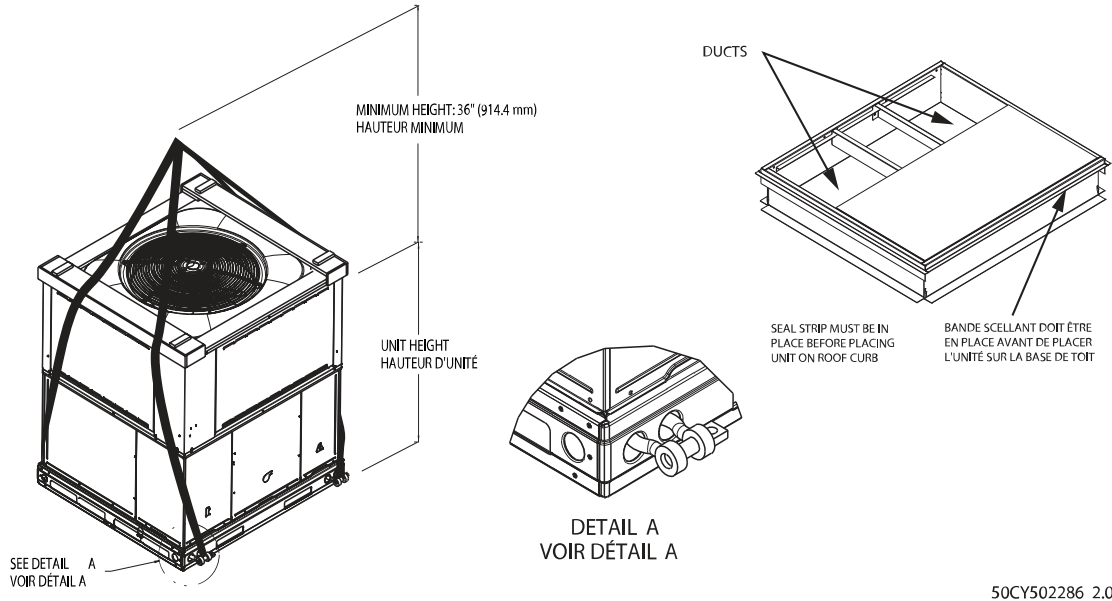

50CY502286 2.0

A09051

RIGGING WEIGHTS (SMALL CABINET)					RIGGING WEIGHTS (LARGE CABINET)								
Unit	24		30		Unit	36		42		48		60	
	lb	kg	lb	kg		lb	kg	lb	kg	lb	kg	lb	kg
Rigging Weight	343	155.6	376	170.6	Rigging Weight	420	190.6	440	199.6	440	199.6	510	231.4

NOTE: See dimensional drawing for corner weight distribution.

Fig. 5 – Rigging Weights

## Step 4 – Rig and Place Unit

### ⚠ WARNING

#### PERSONAL INJURY OR PROPERTY DAMAGE HAZARD

Failure to follow this warning could result in personal injury, death or property damage.

When installing the unit on a rooftop, be sure the roof will support the additional weight.

Rigging and handling of this equipment can be hazardous for many reasons due to the installation location (roofs, elevated structures, etc.).

Only trained, qualified crane operators and ground support staff should handle and install this equipment.

When working with this equipment, observe precautions in the literature, on tags, stickers, and labels attached to the equipment, and any other safety precautions that might apply.

Training for operators of the lifting equipment should include, but not be limited to, the following:

1. Application of the lifter to the load, and adjustment of the lifts to adapt to various sizes or kinds of loads.
2. Instruction in any special operation or precaution.
3. Condition of the load as it relates to operation of the lifting kit, such as balance, temperature, etc.

Follow all applicable safety codes. Wear safety shoes and work gloves.

### Inspection

Prior to initial use, and at monthly intervals, all rigging shackles, clevis pins, and straps should be visually inspected for any damage, evidence of wear, structural deformation, or cracks. Particular attention should be paid to excessive wear at hoist hooking points and load support areas. Materials showing any kind of wear in these areas must not be used and should be discarded.

### ⚠ WARNING

#### UNIT FALLING HAZARD

Failure to follow this warning could result in personal injury or death. Never stand beneath rigged units or lift over people.

1. Leave top shipping skid on the unit for use as a spreader bar to prevent the rigging straps from damaging the unit. If the skid is not available, use a spreader bar of sufficient length to protect the unit from damage.

### ⚠ WARNING

#### PROPERTY DAMAGE HAZARD

Failure to follow this warning could result in personal injury or death. When straps are taut, the clevis should be a minimum of 36 in. (914 mm) above the unit top cover.

**Rigging/Lifting of Unit (See Fig. 5)**

Lifting holes are provided in base rails as shown.

1. Attach shackles, clevis pins, and straps to the base rails of the unit. Be sure materials are rated to hold the weight of the unit (See Fig. 5).
2. Attach a clevis of sufficient strength in the middle of the straps. Adjust the clevis location to ensure unit is lifted level with the ground.

After the unit is placed on the roof curb or mounting pad, remove the top skid.

**Step 5 – Select and Install Ductwork**

The design and installation of the duct system must be in accordance with the standards of the NFPA for installation of non-residence type air conditioning and ventilating systems, NFPA 90A or residence-type, NFPA 90B and/or local codes and ordinances.

Select and size ductwork, supply-air registers, and return air grilles according to ASHRAE (American Society of Heating, Refrigeration, and Air Conditioning Engineers) recommendations.

The unit has duct flanges on the supply- and return-air openings on the side of the unit.

**! WARNING****PERSONAL INJURY HAZARD**

Failure to follow this warning could result in personal injury or death.

For vertical supply and return units, tools or parts could drop into ductwork. Install a 90 degree turn in the return ductwork between the unit and the conditioned space. If a 90 degree elbow cannot be installed, then a grille of sufficient strength and density should be installed to prevent objects from falling into the conditioned space. Units with electric heaters require 90 degree elbow in supply duct.

When designing and installing ductwork, consider the following:

1. All units should have field-supplied filters or accessory filter rack installed in the return-air side of the unit. Recommended sizes for filters are shown in Table 1.
2. Avoid abrupt duct size increases and reductions. Abrupt change in duct size adversely affects air performance.

**IMPORTANT:** Use flexible connectors between ductwork and unit to prevent transmission of vibration. Use suitable gaskets to ensure weather tight and airtight seal. When electric heat is installed, use fireproof canvas (or similar heat resistant material) connector between ductwork and unit discharge connection. If flexible duct is used, insert a sheet metal sleeve inside duct. Heat resistant duct connector (or sheet metal sleeve) must extend 24-in. (610 mm) from electric heater element.

3. Size ductwork for cooling air quantity (cfm). The minimum air quantity for proper electric heater operation is listed in Table 2. Heater limit switches may trip at air quantities below those recommended.
4. Seal, insulate, and weatherproof all external ductwork. Seal, insulate and cover with a vapor barrier all ductwork passing through conditioned spaces. Follow latest Sheet Metal and Air Conditioning Contractors National Association (SMACNA) and Air Conditioning Contractors Association (ACCA) minimum installation standards for residential heating and air conditioning systems.
5. Secure all ducts to building structure. Flash, weatherproof, and vibration-isolate duct openings in wall or roof according to good construction practices.

**Configuring Units for Downflow (Vertical) Discharge****! WARNING****ELECTRICAL SHOCK HAZARD**

Failure to follow this warning could result in personal injury or death. Before performing service or maintenance operations on the system, turn off main power to unit and install lockout tag. There may be more than one disconnect switch.

1. Open all electrical disconnects and install lockout tag before starting any service work.
2. Remove horizontal (metal) ductcovers to access vertical (downflow) discharge duct knockouts in unit basepan. (See Fig. 6.)
3. To remove downflow return and supply knockout covers, break front and right side connecting tabs with a screwdriver and hammer. Push cover down to break rear and left side tabs.

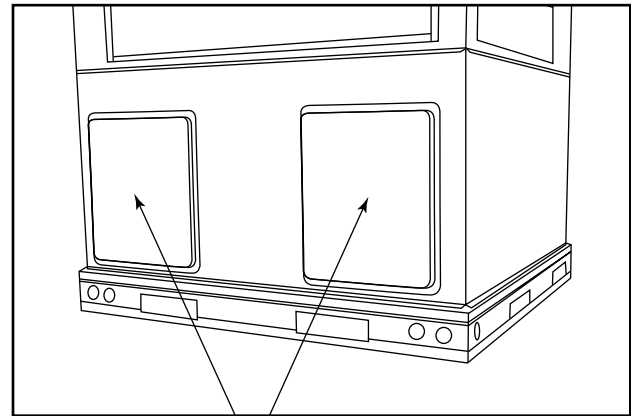

Horizontal Duct Covers

A09510

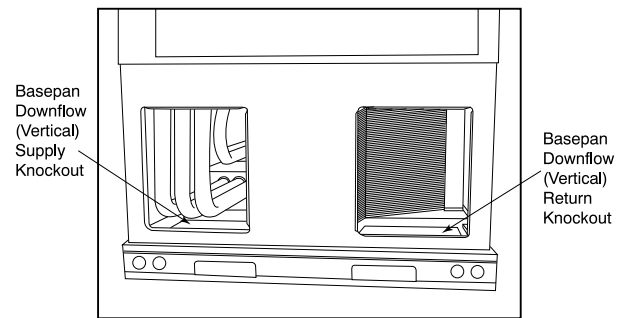
**Fig. 6 – Supply and Return Duct Opening**

A09518

**NOTE:** These panels are held in place with tabs similar to an electrical knockout. Reinstall horizontal duct covers (Fig. 6) shipped on unit from factory. Insure openings are air and watertight.

**NOTE:** The design and installation of the duct system must be in accordance with the standards of the NFPA for installation of nonresidence-type air conditioning and ventilating systems, NFPA 90A or residence-type, NFPA 90B; and/or local codes and ordinances.

Adhere to the following criteria when selecting, sizing, and installing the duct system:

1. Units are shipped for side shot installation.
2. Select and size ductwork, supply-air registers, and return-air grilles according to American Society of Heating, Refrigeration and Air Conditioning Engineers (ASHRAE) recommendations.

3. Use flexible transition between rigid ductwork and unit to prevent transmission of vibration. The transition may be screwed or bolted to duct flanges. Use suitable gaskets to ensure weather-tight and airtight seal.
4. All units must have field-supplied filters or accessory filter rack installed in the return-air side of the unit. Recommended sizes for filters are shown in Table 1.
5. Size all ductwork for maximum required airflow (either heating or cooling) for unit being installed. Avoid abrupt duct size increases or decreases or performance may be affected.
6. Adequately insulate and weatherproof all ductwork located outdoors. Insulate ducts passing through unconditioned space, and use vapor barrier in accordance with latest issue of Sheet Metal and Air Conditioning Contractors National Association (SMACNA) and Air Conditioning Contractors of America (ACCA) minimum installation standards for heating and air conditioning systems. Secure all ducts to building structure.
7. Flash, weatherproof, and vibration-isolate all openings in building structure in accordance with local codes and good building practices.

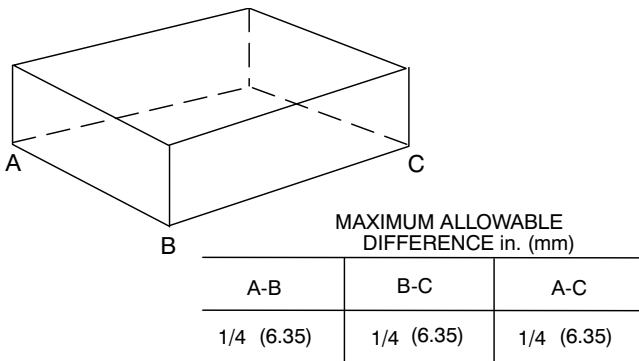

Fig. 7 – Unit Leveling Tolerances A07925

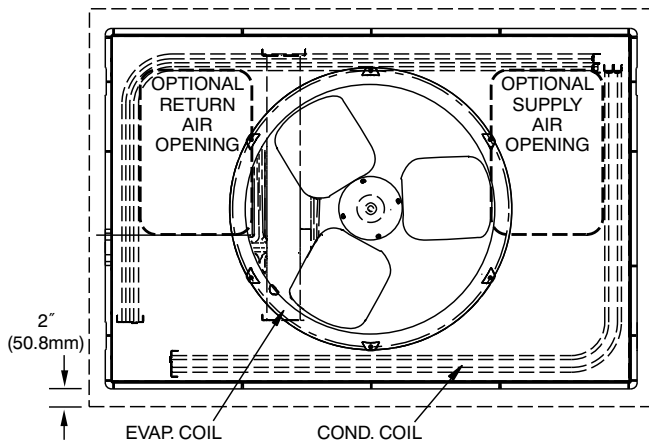

Fig. 8 – Slab Mounting Detail A07926

**Step 6 – Provide for Condensate Disposal**

**NOTE:** Ensure that condensate-water disposal methods comply with local codes, restrictions, and practices.

The unit disposes of condensate through a 3/4 in. NPT female fitting that exits on the compressor end of the unit. Condensate water can be drained directly onto the roof in rooftop installations (where permitted) or onto a gravel apron in ground level installations. Install a field-supplied condensate trap at end of condensate connection to ensure proper drainage. Make sure that the outlet of the trap is at least 1 in. (25 mm) lower than the drain-pan condensate connection to prevent the pan from overflowing. Prime the trap with water. When using a gravel apron, make sure it slopes away from the unit.

If the installation requires draining the condensate water away from the unit, install a field-supplied 2 -in. (51mm) trap at the condensate connection to ensure proper drainage. Condensate trap is available as an accessory or is field-supplied. Make sure that the outlet of the trap is at least 1 in. (25 mm) lower than the unit drain-pan condensate connection to prevent the pan from overflowing. Connect a drain tube using a minimum of field-supplied 3/4-in. PVC or field-supplied 3/4-in. copper pipe at outlet end of the 2-in. (51 mm) trap. (See Fig. 9) Do not undersize the tube. Pitch the drain tube downward at a slope of at least 1 in. (25 mm) every 10 ft (3 m) of horizontal run. Be sure to check the drain trough for leaks. Prime the trap at the beginning of the cooling season start-up.

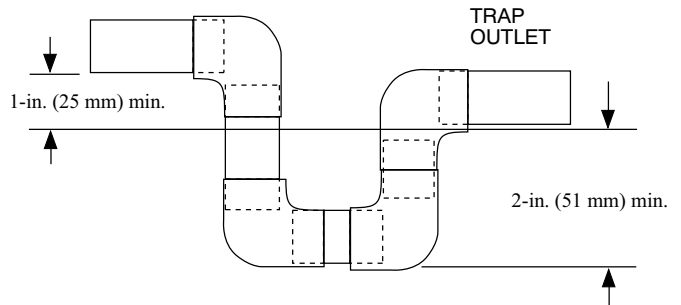

Fig. 9 – Condensate Trap A09052

**Step 7 – Install Electrical Connections**

**! CAUTION**

**UNIT COMPONENT DAMAGE HAZARD**  
 Failure to follow this caution may result in damage to the unit being installed.

1. Make all electrical connections in accordance with NEC NFPA 70 (latest edition) and local electrical codes governing such wiring. In Canada, all electrical connections must be in accordance with CSA standard C22.1 Canadian Electrical Code Part 1 and applicable local codes. Refer to unit wiring diagram.
2. Use only copper conductor for connections between field-supplied electrical disconnect switch and unit. **DO NOT USE ALUMINUM WIRE.**
3. Be sure that high-voltage power to unit is within operating voltage range indicated on unit rating plate. On 3-phase units, ensure phases are balanced within 2 percent. Consult local power company for correction of improper voltage and/or phase imbalance.
4. Do not damage internal components when drilling through any panel to mount electrical hardware, conduit, etc.
5. Route field power supply(s) away from areas that could be damaged by lawn and garden equipment or other accidental damage.

**! WARNING**

**ELECTRICAL SHOCK HAZARD**  
 Failure to follow this warning could result in personal injury or death. The unit cabinet must have an uninterrupted, unbroken electrical ground. This ground may consist of an electrical wire connected to the unit ground screw in the control compartment, or conduit approved for electrical ground when installed in accordance with NEC, NFPA 70 National Fire Protection Association (latest edition) (in Canada, Canadian Electrical Code CSA C22.1) and local electrical codes.

## High-Voltage Connections

The unit must have a separate electrical service with a field-supplied, waterproof disconnect switch mounted at, or within sight from the unit. Refer to the unit rating plate, NEC and local codes for maximum fuse/circuit breaker size and minimum circuit amps (ampacity) for wire sizing.

The field-supplied disconnect may be mounted on the unit over the high-voltage inlet hole when the standard power and low-voltage entry points are used. See Fig. 2 and Fig. 3 for acceptable location. Remove high voltage knockout.

See unit wiring label (Fig. 12 - Fig. 17) and Fig. 10 for reference when making high voltage connections. Proceed as follows to complete the high-voltage connections to the unit.

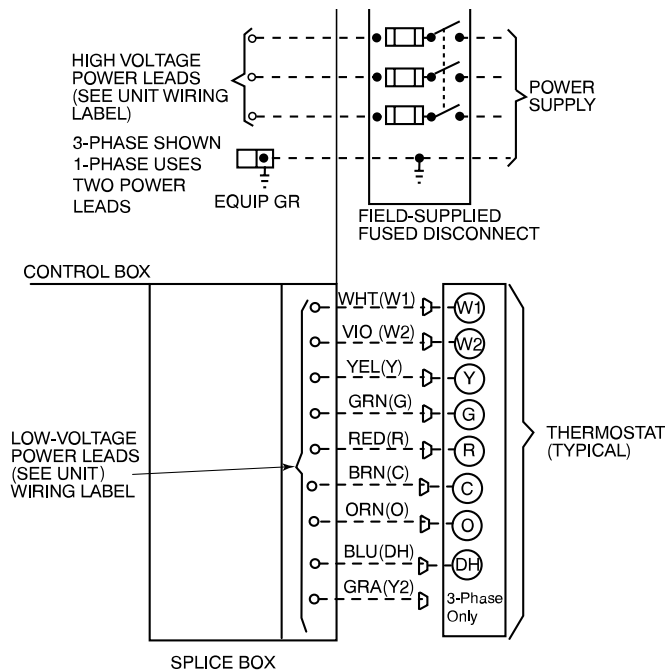

Fig. 10 – High- and Control-Voltage Connections

A09071

Single phase units:

1. Run the high-voltage (L1, L2) and ground lead into the control box.
2. Connect ground lead to chassis ground connection.
3. Locate the black and yellow wires connected to the line side of the contactor.
4. Connect field L1 to black wire on connection 11 of the compressor contactor.
5. Connect field wire L2 to yellow wire on connection 23 of the compressor contactor.

Three-phase units:

1. Run the high-voltage (L1, L2, L3) and ground lead into the control box.
2. Connect ground lead to chassis ground connection.
3. Locate the black and yellow wires connected to the line side of the contactor.
4. Connect field L1 to black wire on connection 11 of the compressor contactor.
5. Connect field wire L3 to yellow wire on connection 13 of the compressor contactor.
6. Connect field wire L2 to blue wire from compressor.

## Special Procedures for 208-V Operation



**WARNING**

### ELECTRICAL SHOCK HAZARD

Failure to follow this warning could result in personal injury or death.

Before installing or servicing system, always turn off main power to system. Tag the disconnect switch with a suitable warning label. With disconnect switch open, move black wire from transformer (3/16 in.) terminal marked 230 to terminal marked 208. This retaps transformer to primary voltage of 208 vac.

## Control Voltage Connections

**NOTE:** Do not use any type of power-stealing thermostat. Unit control problems may result.

Use no. 18 American Wire Gage (AWG) color-coded, insulated (35°C minimum) wires to make the control voltage connections between the thermostat and the unit. If the thermostat is located more than 100 ft (30.5 m) from the unit (as measured along the control voltage wires), use no. 16 AWG color-coded, insulated (35°C minimum) wires.

## Standard Connections

Locate the eight (nine on 3-phase) low voltage thermostat leads in 24 volt splice box. See Fig. 10 for connection diagram. Run the low-voltage leads from the thermostat, through the control wiring inlet hole grommet (see Fig. 2 and Fig. 3), and into the low-voltage splice box. Provide a drip loop before running wires through panel. Secure and strain relief all wires so that they do not interfere with operation of unit. A gray wire is standard on 3-phase units for connection to an economizer.

If an accessory electric heater is installed, low voltage leads from heater must be connected to factory supplied control leads from Indoor Fan Board P4 connector.

**NOTE:** If the unit 24V wires do not have a matching receptacle, cut the 24V wires from the electric heater plug, strip the ends, and wire nut together to match the schematic connections. If the electric heater 24V wires do not have a matching plug, cut the 24V wires from the unit receptacle, strip the ends, and wire nut together to match the schematic connections.

Factory wires are provided for electric heat staging W1 and W2 (W2 and W3 on IFB). If room thermostat has only one stage of supplemental heat, connect white and violet wires shown in Fig. 10 to second stage heat field wire.

Some electric heaters have four control wires (plus common wire). Consult unit wiring diagram and electric heater wiring diagram for additional details.

## Transformer Protection

The transformer is of the energy-limiting type. It is set to withstand a 30-second overload or shorted secondary condition. If an overload or short is present, correct overload condition and check for blown fuse on Interface Fan Board. Replace fuse as required with correct size and rating.

## Accessory Electric Heaters Installation

Electric heaters may be installed with the unit per instructions supplied with electric heater package. See unit rating plate for factory-approved electric heater kits.

## Sequence of Operation

- a. CONTINUOUS FAN
  - (1.) Thermostat closes circuit R to G energizing the blower motor for continuous fan.
- b. COOLING MODE
  - (1.) If indoor temperature is above temperature set point, thermostat closes circuits R to G, R to Y and R to O-The unit delivers cooling airflow.

c. ELECTRIC HEATING MODE

(1.) Thermostat closes circuit R to W/W1, or W2 and R to G.

There are no on or off delays.

d. HEAT PUMP HEATING MODE

(1.) Thermostat closes circuits R to G and R to Y. The compressor, indoor and outdoor fans are energized.

e. HEAT PUMP HEATING WITH AUXILIARY ELECTRIC HEAT

(1.) Thermostat closes circuits R to G, R to Y and R to W/W1 or W2. The compressor, indoor and outdoor fans are energized, as well as the electric heat relays.

f. DEFROST MODE

The defrost mode is automatically energized by the defrost board during heating mode. The defrost board energizes “O” (reversing valve) and “W2” (electric heat). It also de-energizes the outdoor fan. When defrost is complete, unit will return to heating mode. If room thermostat is satisfied during defrost, unit will shut down and restart in defrost on next call for heat.

**Table 1 – Physical Data**

	<b>24</b>	<b>30</b>	<b>36</b>	<b>42</b>	<b>48</b>	<b>60</b>
Unit Size	2	2.5	3	3.5	4	5
Shipping Weight* (lb)	343	376	420	440	440	510
(kg)	155.6	170.6	190.6	199.6	199.6	231.4
Compressor Quantity	1					
Type	Scroll					
Refrigerant	R-410A					
Refrigerant Quantity (lb)	7.25	11.5	10.4	10.5	10.0	13.25
Quantity (kg)	3.3	5.2	4.7	4.8	4.5	6.0
Refrigerant Metering Device	Indoor TXV, Outdoor Dual Accuraters				Indoor Accurater, Outdoor Dual Accuraters	Indoor TXV, Outdoor Dual Accuraters
Orifice ID (in)	N/A				0.080 (1)	N/A
(mm)					2.03 (1)	
Orifice OD (in)	0.032 (2)	0.035 (2)	0.040 (2)	0.046 (2)	0.046 (2)	0.046 (2)
(mm)	0.81 (2)	0.89 (2)	1.02 (2)	1.17 (2)	1.17 (2)	1.17 (2)
Outdoor Coil						
Rows...Fins/in,	1...21	2...21	1...21	1...21	2...21	2...21
face area (sq. ft.)	18.8	18.8	23.3	23.3	13.6	17.5
Outdoor Fan						
Nominal Airflow (cfm)	3000	3500	3500	3500	3500	3500
Diameter (in.)	24	24	26	26	26	26
Diameter (mm)	610	610	660	660	660	660
Motor hp (rpm)	1/10 (810)	1/5 (810)	1/5 (810)	1/5 (810)	1/5 (810)	1/5 (810)
Indoor Coil						
Rows...Fins/in,	3...15	3...17	3...17	3...17	3...17	3...17
face area (sq. ft.)	3.7	3.7	4.7	4.7	5.6	5.6
Indoor Blower						
Nominal Airflow (cfm)	750	950	1150	1350	1600	1750
Size (in.)	10 x 10	10 x 10	11 x 10	11 x 10	11 x 10	11 x 10
Size (mm)	254 x 254	254 x 254	279 x 254	279 x 254	279 x 254	279 x 254
Motor hp (rpm)	1/2	1/2	1/2	3/4	1	1
High Pressure Switch (psig)	650 +/- 15					
Cutout	420 +/- 25					
Reset (Auto)						
Loss-of-Charge/Low Pressure Switch (psig)	20 +/- 5					
Cutout	45 +/- 10					
Reset (Auto)						
Return Air Filters disposable†	2 each 20x12x1 in. 508x305x25 mm		1 each 24x14x1 in. 610x356x25 mm 24x16x1 in. 610x406x25 mm		1 each 24x16x1 in. 610x406x25 mm 24x18x1 in. 610x457x25 mm	

\*. For 460 volt units, add 14 lb (6.4 kg) to the weight.

†. Required filter sizes shown are based on the larger of the AHRI (Air Conditioning Heating and Refrigeration Institute) rated cooling airflow or the heating airflow velocity of 300-350 ft/minute for throwaway type or 450 ft/minute for high-capacity type. Air filter pressure drop for non-standard filters must not exceed 0.08 IN. W.C. If using accessory filter rack refer to the filter rack installation instructions for correct filter size and quantity.

**Table 2 – Minimum Airflow for Reliable Electric Heater Operation (CFM)**

<b>SIZE</b>	<b>24</b>	<b>30</b>	<b>36</b>	<b>42</b>	<b>48</b>	<b>60</b>
AIRFLOW (CFM)	800	1025	1250	1400	1710	1800

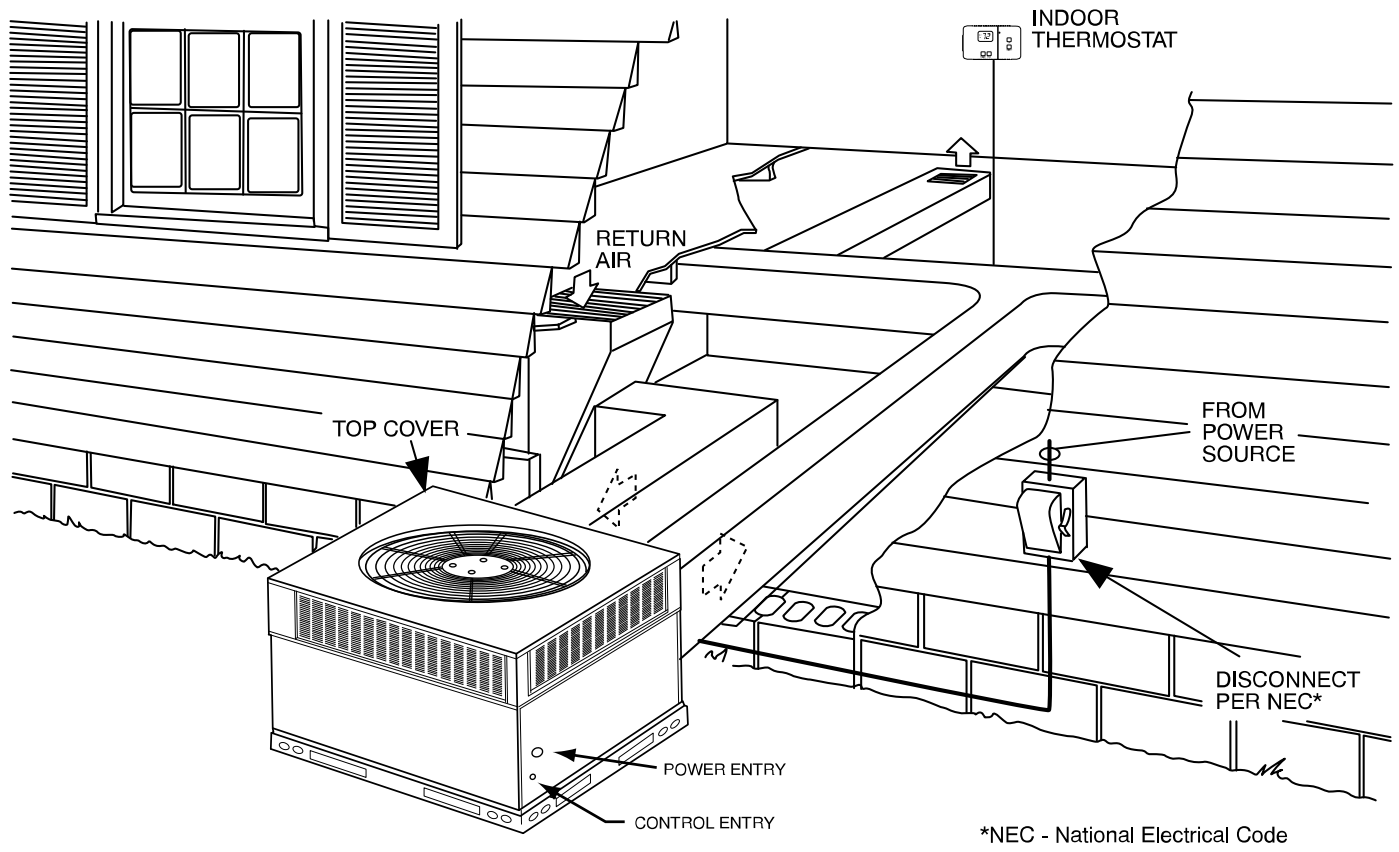

**Fig. 11 – Typical Installation**

A09098

**CONNECTION WIRING DIAGRAM**

**DANGER: ELECTRICAL SHOCK HAZARD DISCONNECT POWER BEFORE SERVICING**

**SCHEMATIC 208/230V-1-60**

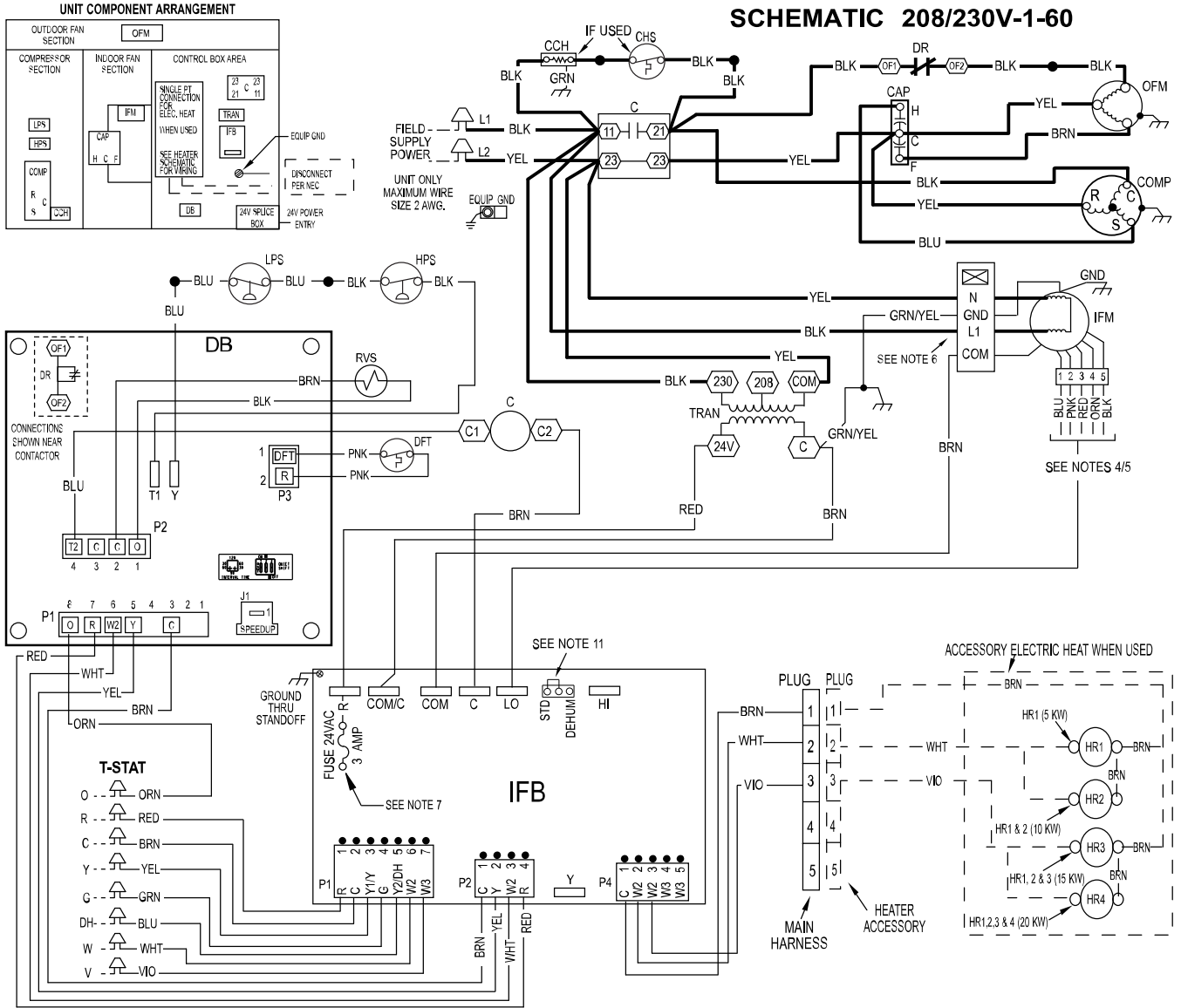

**NOTES:**

1. IF ANY OF THE ORIGINAL WIRES FURNISHED ARE REPLACED IT MUST BE REPLACED WITH THE SAME OR ITS EQUIVALENT.
2. SEE PRE SALE LITERATURE FOR THERMOSTATS.
3. USE 75 DEGREES C COPPER CONDUCTORS FOR FIELD INSTALLATION.
4. REFER TO INSTALLATION INSTRUCTIONS FOR CORRECT SPEED SELECTION FOR IFM.
5. RELOCATION OF SPEED TAPS MAY BE REQUIRED WHEN USING FIELD INSTALLED ELECTRIC HEATERS. CONSULT INSTALLATION INSTRUCTIONS TO DETERMINE CORRECT SPEED TAP SETTING.
6. "DO NOT DISCONNECT PLUG UNDER LOAD".
7. THIS FUSE IS MANUFACTURED BY LITTLE FUSE, P/N 267003.
8. N.E.C. CLASS 2, 24V.
9. UNIT FACTORY - SHIPPED IN STD MODE.
10. CCH NOT USED ON ALL UNITS.
11. DEHUM FEATURE CANNOT BE USED WHEN ECONOMIZER IS INSTALLED. UNIT FACTORY - SHIPPED IN STD MODE.

**LEGEND**

	FIELD SPLICE	C	CONTACTOR	IFM	INDOOR FAN MOTOR
	TERMINAL (MARKED)	CAP	CAPACITOR	LPS	LOW PRESSURE SWITCH
	TERMINAL (UNMARKED)	CCH	CRANKCASE HEATER	OFM	OUTDOOR FAN MOTOR
	SPLICE	COMP	COMPRESSOR MOTOR	RVS	REVERSING VALVE
	SPLICE (MARKED)	CTD	COMPRESSOR TIME DELAY	TRAN	TRANSFORMER
	FACTORY LO VOLTAGE	DH	DEHUM	T-STAT	THERMOSTAT
	FIELD CONTROL WIRING	DB	DEFROST BOARD		
	FIELD POWER WIRING	DFT	DEFROST TEMPERATURE SWITCH		
	ACCESSORY OR OPTIONAL WIRING	DR	DEFROST RELAY (SEE DB)		
	FACTORY HI VOLTAGE	GND	GROUND		
		HPS	HIGH PRESSURE SWITCH		
		HR	HEATER RELAY		
		IFB	INDOOR FAN BOARD		

**Fig. 12 – Connection Wiring Schematics 208/230-1-60**

A221468

### LADDER WIRING DIAGRAM

**DANGER: ELECTRICAL SHOCK HAZARD DISCONNECT POWER BEFORE SERVICING**

**DEFROST TIMING SELECTION**

FIELD SELECTABLE OPTIONS FOR TIME PERIOD BETWEEN DEFROST CYCLES (MINUTES)  
FACTORY DEFROST SETTING IS 60 MIN.

INTERVAL TIME: 30, 60, 90, 120

ON OFF QUIET SHIFT

SPEED UP JUMPERED TEST PINS (USE METAL OBJECT) FIELD SPEED-UP CYCLE

- DFT MUST BE CLOSED TO INITIATE DEFROST CYCLE. IF NECESSARY, REMOVE DFT CONNECTION BEFORE PLACING JUMPER ACROSS DFT PINS.
- AT THE SAME TIME DFT CLOSED, JUMPER "SPEED UP" PINS WITH SMALL SCREW DRIVER UNTIL DEFROST IS INITIATED. THEN REMOVE SCREW DRIVER.
- SHORTED "SPEED UP" PINS WILL SPEED UP TIMER BY A FACTOR OF 25%.

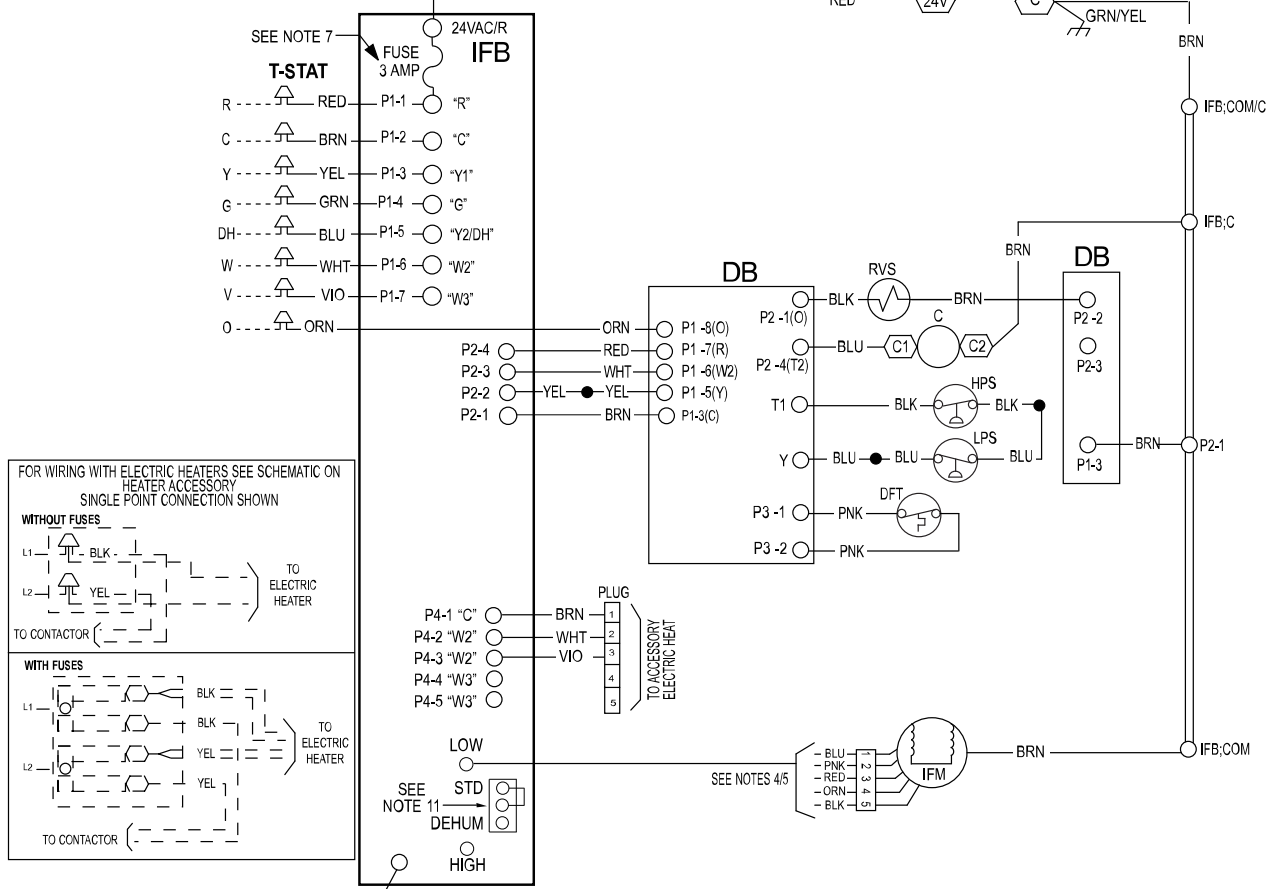
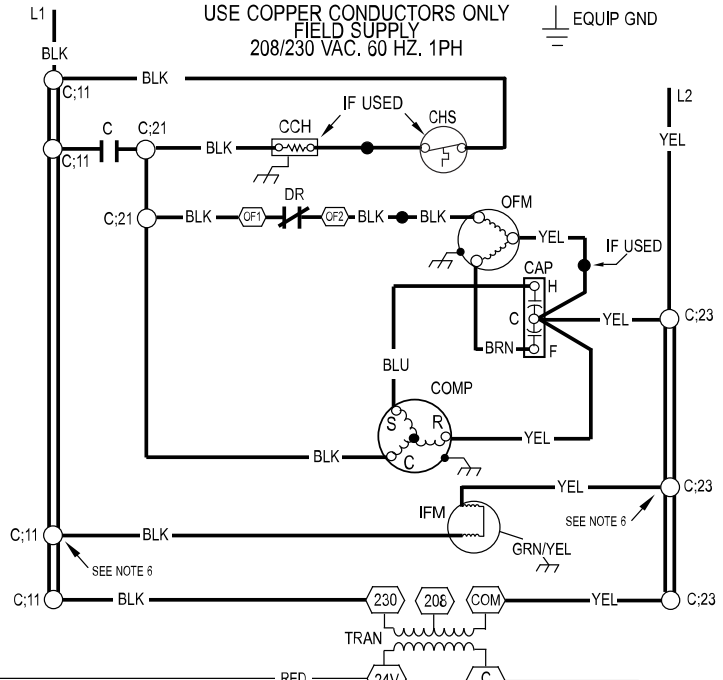

349044-201 REV. A



349044-201 REV. A

Fig. 13 – Ladder Wiring Schematics 208/230-1-60

**CONNECTION WIRING DIAGRAM**  
**DANGER: ELECTRICAL SHOCK HAZARD DISCONNECT POWER BEFORE SERVICING**

**SCHEMATIC 208/230V-3-60**

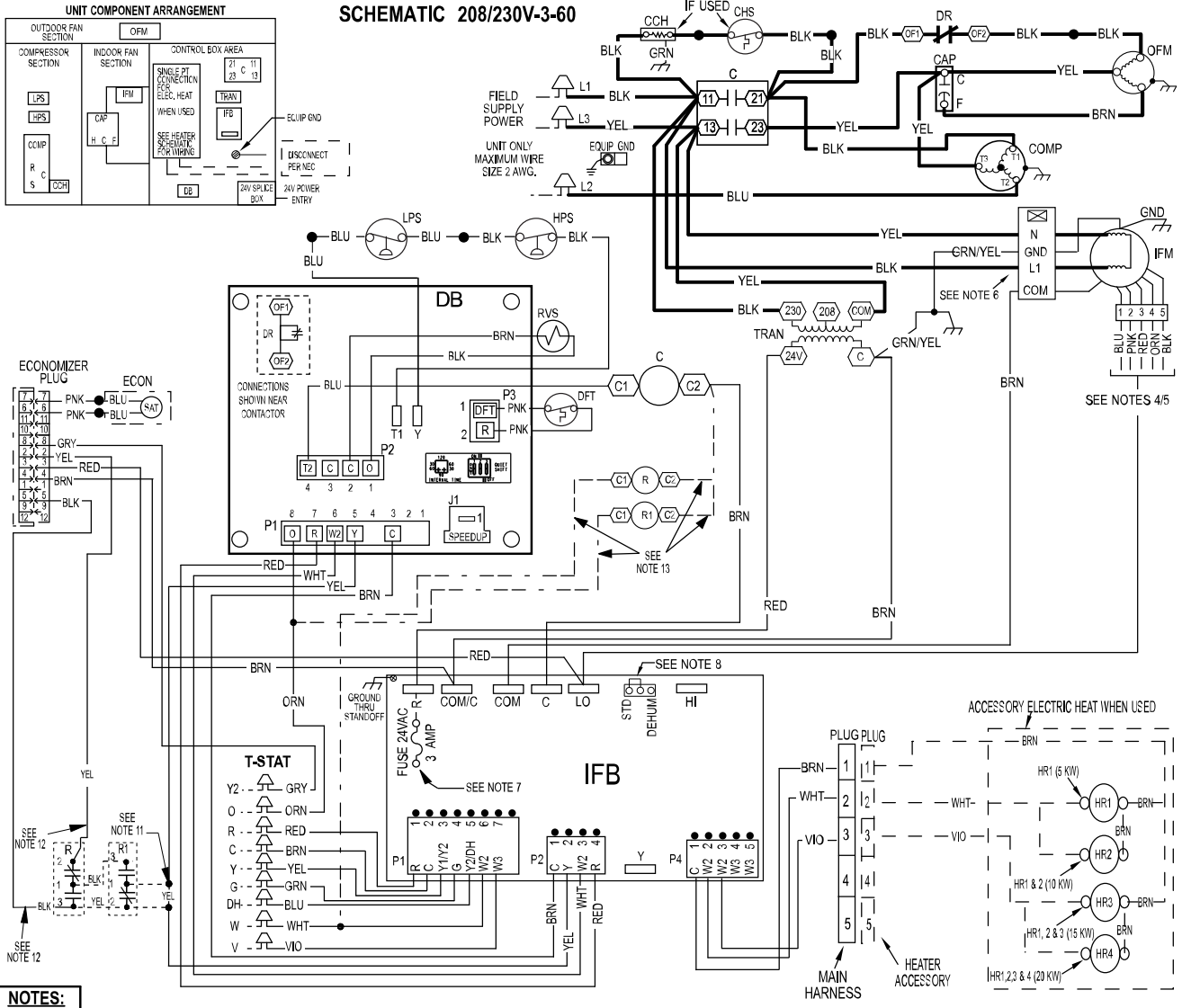

**NOTES:**

1. IF ANY OF THE ORIGINAL WIRES FURNISHED ARE REPLACED IT MUST BE REPLACED WITH THE SAME OR ITS EQUIVALENT.
2. SEE PRE SALE LITERATURE FOR THERMOSTATS.
3. USE 75 DEGREES C COPPER CONDUCTORS FOR FIELD INSTALLATION.
4. REFER TO INSTALLATION INSTRUCTIONS FOR CORRECT SPEED SELECTION FOR IFM.
5. RELOCATION OF SPEED TAPS MAY BE REQUIRED WHEN USING FIELD INSTALLED ELECTRIC HEATERS. CONSULT INSTALLATION INSTRUCTIONS TO DETERMINE CORRECT SPEED TAP SETTING.
6. "DO NOT DISCONNECT PLUG UNDER LOAD".
7. THIS FUSE IS MANUFACTURED BY LITTLE FUSE, P/N 287003.
8. DEHUM FEATURE CANNOT BE USED WHEN ECONOMIZER IS INSTALLED. UNIT FACTORY - SHIPPED IN STD MODE.
9. N.E.C. CLASS 2, 24V.
10. CCH NOT USED ON ALL UNITS.
11. REMOVE YELLOW SPLICE WHEN ECONOMIZER AND ECONOMIZER RELAYS ARE USED AND CONNECT TO RELAY R1 AS SHOWN.
12. WHEN ECONOMIZER AND ECONOMIZER RELAYS ARE USED CONNECT THE YELLOW AND BLACK WIRES TO RELAY "R" AS SHOWN. RELAY KIT REQUIRED WITH ECONOMIZER AND HEAT PUMP / DUAL FUEL UNITS.
13. WHEN ECONOMIZER AND ECONOMIZER RELAYS ARE USED, INSTALL WIRES AS SHOWN ONTO THE COILS OF RELAY R AND RELAY R1.

**LEGEND**

	FIELD SPLICE		C	CONTACTOR		HR	HEATER RELAY
	TERMINAL (MARKED)		CAP	CAPACITOR		IFB	INDOOR FAN BOARD
	TERMINAL (UNMARKED)		CCH	CRANK CASE HEATER		IFM	INDOOR FAN MOTOR
	SPLICE		COMP	COMPRESSOR MOTOR		LPS	LOW PRESSURE SWITCH
	SPLICE (MARKED)		DB	DEFROST BOARD		OFM	OUTDOOR FAN MOTOR
	FACTORY LO VOLTAGE		DH	DEHUMIDIFICATION MODE		RVS	REVERSING VALVE
	FIELD CONTROL WIRING		DFT	DEFROST TEMPERATURE SWITCH		STD	STANDARD MODE
	FIELD POWER WIRING		DEHUM	DEHUMIDIFICATION MODE		TRAN	TRANSFORMER
	ACCESSORY OR OPTIONAL WIRING		T-STAT	THERMOSTAT			
	FACTORY HI VOLTAGE						



**Fig. 14 – Connection Wiring Schematics - 208/230-3-60**

## LADDER WIRING DIAGRAM

### DANGER: ELECTRICAL SHOCK HAZARD DISCONNECT POWER BEFORE SERVICING

**DEFROST TIMING SELECTION**

FIELD SELECTABLE OPTIONS FOR TIME PERIOD BETWEEN DEFROST CYCLES (MINUTES)  
FACTORY DEFROST SETTINGS IS 60 MIN.

SPEED UP  JUMPERED TEST PINS (USE METAL OBJECT) FIELD SPEED-UP CYCLE

- DFT MUST BE CLOSED TO INITIATE DEFROST CYCLE. IF NECESSARY, REMOVE DFT CONNECTION BEFORE PLACING JUMPER ACROSS DFT PINS.
- AT THE SAME TIME DFT CLOSED, JUMPER 'SPEED UP' PINS WITH SMALL SCREW DRIVER UNTIL DEFROST IS INITIATED. THEN REMOVE SCREW DRIVER.
- SHORTED 'SPEED UP' PINS WILL SPEED UP TIMER BY A FACTOR OF 25%.

FOR WIRING WITH ELECTRIC HEATERS SEE SCHEMATIC ON HEATER ACCESSORY

SINGLE POINT CONNECTION SHOWN

WITHOUT FUSES

TO CONTACTOR

WITH FUSES

TO CONTACTOR

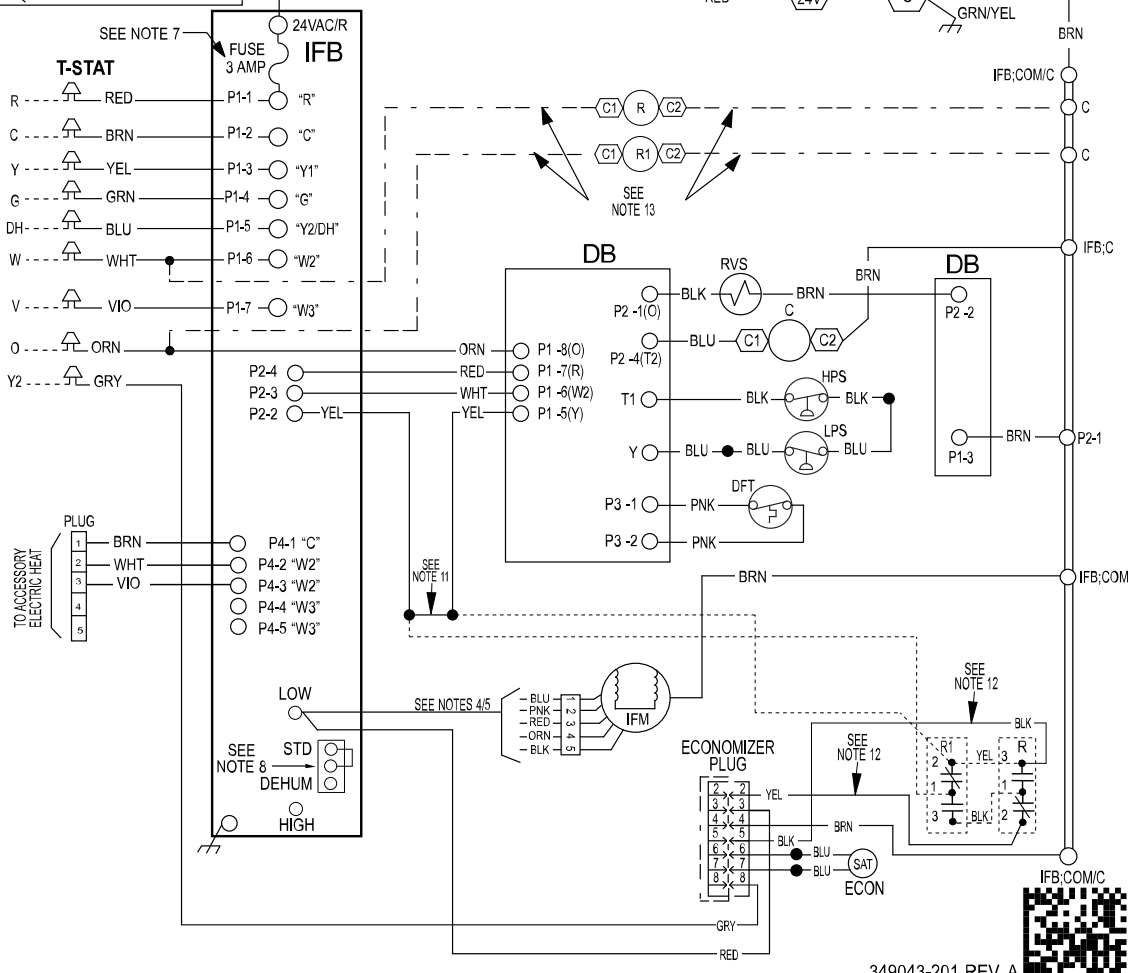
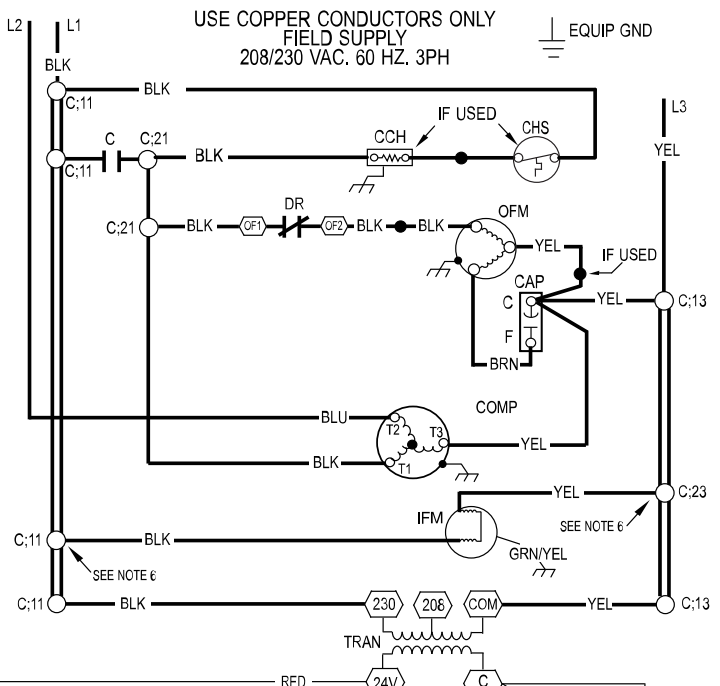

349043-201 REV. A

Fig. 15 – Ladder Wiring Schematics - 208/230-3-60





## Pre-Start-Up

### WARNING

#### **FIRE, EXPLOSION, ELECTRICAL SHOCK AND ENVIRONMENTAL HAZARD**

Failure to follow this warning could result in personal injury, death or property damage.

1. Follow recognized safety practices and wear protective goggles when checking or servicing refrigerant system.
2. Relieve and recover all refrigerant from system before touching or disturbing compressor plug if refrigerant leak is suspected around compressor terminals.
3. Do not remove compressor plug until all electrical sources are disconnected and tagged.
4. Never attempt to repair soldered connection while refrigerant system is under pressure.
5. Do not use torch to remove any component. System contains oil and refrigerant under pressure.  
To remove a component, wear protective goggles and proceed as follows:
  - a. Shut off electrical power to unit and install lockout tag.
  - b. Relieve and reclaim all refrigerant from system using both high- and low-pressure ports.
  - c. Cut component connecting tubing with tubing cutter and remove component from unit.
  - d. Carefully unsweat remaining tubing stubs when necessary. Oil can ignite when exposed to torch flame.

Use the Start-Up Checklist supplied at the end of this book and proceed as follows to inspect and prepare the unit for initial start-up:

1. Remove all access panels (see Fig. 23).
2. Read and follow instructions on all DANGER, WARNING, CAUTION, and INFORMATION labels attached to, or shipped with, unit.
3. Make the following inspections:
  - a. Inspect for shipping and handling damages such as broken lines, loose parts, disconnected wires, etc.
  - b. Inspect all field and factory-wiring connections. Be sure that connections are completed and tight. Ensure wires do not touch refrigerant tubing or sharp sheet metal edges.
  - c. Inspect coil fins. If damaged during shipping and handling, carefully straighten fins with a fin comb.
4. Verify the following conditions:
  - a. Make sure that outdoor-fan blade is correctly positioned in fan orifice.
  - b. Make sure that air filter(s) is in place.
  - c. Make sure that condensate drain pan and trap are filled with water to ensure proper drainage.
  - d. Make sure that all tools and miscellaneous loose parts have been removed.
5. Each unit system has 2 Schrader-type ports, one low-side Schrader fitting located on the suction line, and one high-side Schrader fitting located on the compressor discharge line. Be sure that caps on the ports are tight.

## Start-Up

### **Checking Cooling and Heating Control Operation**

Start and check the unit for proper control operation as follows:

- (1.) Place room thermostat SYSTEM switch or MODE control in OFF position. Observe that blower motor starts when

FAN mode is placed in FAN ON position and shuts down when FAN MODE switch is placed in AUTO position.

- (2.) Thermostat:  
When the room temperature rises to a point that is slightly above the cooling control setting of the thermostat, the thermostat completes the circuit between thermostat terminal R to terminals Y, O and G. These completed circuits through the thermostat connect contactor coil (C) (through unit wire Y) and Indoor Fan board (through unit wire G) across the 24-v. secondary of transformer (TRAN).
- (3.) Place system switch or MODE control in HEAT position. Set control above room temperature. Observe that compressor, outdoor fan, and indoor blower motors start. Observe that heating cycle shuts down when control setting is satisfied.
- (4.) When using an automatic changeover room thermostat place both SYSTEM or MODE control and FAN mode switches in AUTO positions. Observe that unit operates in Cooling mode when temperature control is set to "call for Cooling" (below room temperature), and unit operates in Heating mode when temperature control is set to "call for Heating" (above room temperature).

**NOTE:** Once the compressor has started and then has stopped, it should not be started again until 5 minutes have elapsed. The defrost board has a built-in 5 minute delay between cycles. The 5 minute compressor delay also applies to heat pump heating mode.

### Step 1 – Check for Refrigerant Leaks

### WARNING



#### **EXPLOSION HAZARD**

Failure to follow this warning could result in death, serious personal injury, and/or property damage.

Never use air or gases containing oxygen for leak testing or operating refrigerant compressors. Pressurized mixtures of air or gases containing oxygen can lead to an explosion.

Proceed as follows to locate and repair a refrigerant leak and to charge the unit:

1. Locate leak and make sure that refrigerant system pressure has been relieved and reclaimed from both high- and low-pressure ports.
2. Repair leak following Refrigerant Service procedures.

**NOTE:** Install a bi-flow filter drier whenever the system has been opened for repair.

3. Add a small charge of R-410A refrigerant vapor to system and leak-test unit.
4. Recover refrigerant from refrigerant system and evacuate to 500 microns if no additional leaks are not found.
5. Charge unit with R-410A refrigerant, using an electronic scale. Refer to unit rating plate for required charge.

### Step 2 – Start-Up Adjustments

Complete the required procedures given in the Pre-Start-Up section before starting the unit. Do not jumper any safety devices when operating the unit. Do not operate the unit in Cooling mode when the outdoor temperature is below 40°F (4°C) (unless accessory low-ambient kit is installed).

**IMPORTANT:** Three-phase, scroll compressors are direction oriented. Unit must be checked to ensure proper compressor 3-phase power lead orientation. If not corrected within 5 minutes, the internal protector will shut off the compressor. The 3-phase power leads to the unit must be

reversed to correct rotation. When turning backwards, the difference between compressor suction and discharge pressures may be near zero.

### **Checking and Adjusting Refrigerant Charge**

The refrigerant system is fully charged with R-410A refrigerant and is tested and factory sealed

<b>! WARNING</b>	
	<b>EXPLOSION HAZARD</b>
	<p>Failure to follow this warning could result in death, serious personal injury, and/or property damage.</p> <p>Never use air or gases containing oxygen for leak testing or operating refrigerant compressors. Pressurized mixtures of air or gases containing oxygen can lead to an explosion.</p>

**NOTE:** Adjustment of the refrigerant charge is not required unless the unit is suspected of not having the proper R-410A charge.

**NOTE:** Some units have fixed orifice refrigerant metering devices. There is a different charging procedure for both expansion devices. Refer to the correct procedure for your unit.

The charging label and the tables shown refer to system temperatures and pressures in cooling mode only. A refrigerant charging label is attached to the inside of the compressor access panel. (See Fig. 21 Subcool chart for units with TXV and superheat chart for units with fixed orifice.) The chart includes the required liquid line temperature at given discharge line pressures and outdoor ambient temperatures.

A superheat chart is attached to the inside of the compressor access panel for the unit with fixed metering device. Refer to the charging procedure on the label.

An accurate thermocouple- or thermistor-type thermometer, and a gauge manifold are required when using the subcooling charging method for evaluating the unit charge. Do not use mercury or small dial-type thermometers because they are not adequate for this type of measurement.

**NOTE:** Allow system to operate for a minimum of 15 minutes before checking or adjusting refrigerant charge.

**IMPORTANT:** When evaluating the refrigerant charge, an indicated adjustment to the specified factory charge must always be very minimal. If a substantial adjustment is indicated, an abnormal condition exists somewhere in the cooling system, such as insufficient airflow across either coil or both coils.

Proceed as follows:

1. Remove caps from low- and high-pressure service fittings.
2. Using hoses with valve core depressors, attach low- and high-pressure gauge hoses to low- and high-pressure service fittings, respectively.
3. Start unit and let run until system pressures stabilize.
4. Measure and record the following:
  - a. Outdoor ambient-air temperature (°F [°C] db).
  - b. Liquid line temperature (°F [°C]) at TXV.
  - c. Discharge (high-side) pressure (psig).
  - d. Suction (low-side) pressure (psig) (for reference only).
5. Using Cooling Charging Charts compare outdoor-air temperature (°F [°C] db) with the discharge line pressure (psig) to determine desired system operating liquid line temperature (See Fig. 21.)
6. Compare actual liquid line temperature with desired liquid line temperature. Using a tolerance of  $\pm 2^{\circ}\text{F}$  ( $\pm 1.1^{\circ}\text{C}$ ), add refrigerant if actual temperature is more than  $2^{\circ}\text{F}$  ( $1.1^{\circ}\text{C}$ ) higher than proper liquid line temperature, or remove refrigerant if actual temperature

is more than  $2^{\circ}\text{F}$  ( $1.1^{\circ}\text{C}$ ) lower than required liquid line temperature.

**NOTE:** If the problem causing the inaccurate readings is a refrigerant leak, refer to Check for Refrigerant Leaks section.

### **Indoor Airflow and Airflow Adjustments**

<b>! WARNING</b>	
<b>UNIT OPERATION HAZARD</b>	
<p>Failure to follow this caution may result in unit damage.</p> <p>For cooling operation, the recommended airflow is 350 to 450 cfm for each 12,000 Btuh of rated cooling capacity. For heating operation, the airflow must produce a temperature rise that falls within the range stamped on the unit rating plate.</p>	

**NOTE:** Be sure that all supply-and return-air grilles are open, free from obstructions, and adjusted properly.

<b>! WARNING</b>	
<b>ELECTRICAL SHOCK HAZARD</b>	
<p>Failure to follow this warning could result in personal injury or death.</p> <p>Disconnect electrical power to the unit and install lockout tag before changing blower speed.</p>	

This unit is factory-set up for use with a single cooling fan speed. In addition, this unit has the field-selectable capability to run two different cooling fan speeds: The rated cooling fan speed (350~400 CFM/Ton) and an enhanced dehumidification fan speed (As low as 320 CFM/Ton) for use with either a dehumidistat or a thermostat that supports dehumidification.

The cooling speed is marked “LOW” on the interface fan board (IFB) (See Fig. 19). The factory-shipped settings are noted in Table 4. There are 4 additional speed tap wires available for use in either electric heating or cooling (For color coding on the indoor fan motor leads, see Table 3). The additional 4 speed tap wires are shipped loose with vinyl caps and are located in the control box, near the interface fan board (IFB) (See Fig. 19).

### **Single Cooling Fan Speed Set-up (Dehumidification feature not used)**

To change cooling speed:

1. Remove the vinyl cap off of the desired speed tap wire (Refer to Table 3 for color coding). Add the wet coil pressure drop in Table 6 to the system static to determine the correct cooling airflow speed in Table 4 that will deliver the nominal cooling airflow as listed in Table 1 for each size.
2. Remove the current speed tap wire from the “LOW” terminal on the interface fan board (IFB) (See Fig. 19) and place vinyl cap over the connector on the wire.
3. Connect the desired speed tap wire to the “LOW” terminal on the interface fan board (IFB).

**NOTE:** If accessory electric heat is installed, and the electric heat fan speed is chosen to be the same as the normal cooling fan speed, the dry airflow must meet or exceed the minimum airflow speed specified in Table 2 for the specific size unit.

### **Two Cooling Fan Speeds Set-up (Dehumidification feature used)**

**IMPORTANT:** Dehumidification control must open control circuit on humidity rise above set point.

Use of the dehumidification cooling fan speed requires use of either a 24 VAC dehumidistat or a thermostat which includes control of a 24 VAC dehumidistat connection. In either case, the dehumidification control

must open the control circuit on humidity rise above the dehumidification set point.

1. Using Fig. 19, move the two pin DEHUM jumper from the “STD” position to the “DEHUM” position.
2. Remove fan speed tap wire from the “LOW” terminal on the interface fan board (IFB) (See Fig. 19).
3. Determine correct normal cooling fan speed for unit and application. Add the wet coil pressure drop in Table 6 to the system static to determine the correct cooling airflow speed in Table 4 that will deliver the nominal cooling airflow as listed in Table 1 for each size.

**NOTE:** If accessory electric heat is installed, the dry airflow must meet or exceed the minimum airflow speed specified in Table 2 for the specific size unit. The electric heat fan speed will be the same as the normal cooling fan speed.

4. Remove the vinyl cap off of the desired speed tap wire (Refer to Table 3 for color coding) for the normal cooling fan speed and place desired speed tap wire on “HIGH” on the interface board.
5. Refer to airflow tables (Table 4 - Table 6) to determine allowable speeds for the dehumidification cooling fan speed. In Table 4 - Table 6, speeds that are not allowed for dehumidification cooling are shaded.
6. Remove the vinyl cap off of the desired speed tap wire (Refer to Table 3 for color coding) for the dehumidification cooling fan speed and place desired speed tap wire on the “LOW” connection on the interface board (IFB). Verify that static pressure is in the acceptable range for the speed tap to be used for dehumidification cooling.
7. Use any spare vinyl plugs to cap any unused speed tap wires.

**Single Speed Cooling With Higher Electric Heat Speed**

This unit can also be configured to operate with single speed cooling and a higher speed for an accessory electric heater.

1. Move the two pin DEHUM jumper located on control board (see Fig. 19) from the “STD” position to the “DEHUM” position.
2. See Table 2 for minimum airflow for electric heat operation. Add electric heater and filter pressure drop to duct system static pressure to determine total external static pressure.

3. Select speed tap from Table 4 that will achieve required airflow from Table 2.
4. Remove the vinyl cap off of the desired speed tap wire (Refer to Table 3 for color coding).
5. Connect the desired speed tap wire to the “HIGH” terminal on the interface fan board (IFB).

**! CAUTION**

**UNIT OPERATION HAZARD**  
 Failure to follow this caution may result in unit component damage or improper operation.  
 To use this mode, a speed connection must be made on the “HIGH” terminal that meets or exceeds the minimum airflow found in Table 2.

**Table 3 – Color Coding for Indoor Fan Motor Leads**

Black = High Speed
Orange = Med-High Speed
Red = Med Speed
Pink = Med-Low Speed
Blue = Low Speed

**! WARNING**

**ELECTRICAL SHOCK HAZARD**  
 Failure to follow this warning could result in personal injury or death.  
 Disconnect electrical power to the unit and install lockout tag before changing blower speed.

**Continuous Fan Operation**

When the DEHUM feature is not used, the continuous fan speed will be the same as cooling fan speed. When the DEHUM feature is used, the continuous fan will operate on IFB “LOW” speed when the DH control lead is not energized, or IFB “HIGH” speed when the DH lead is energized (see Fig. 19).

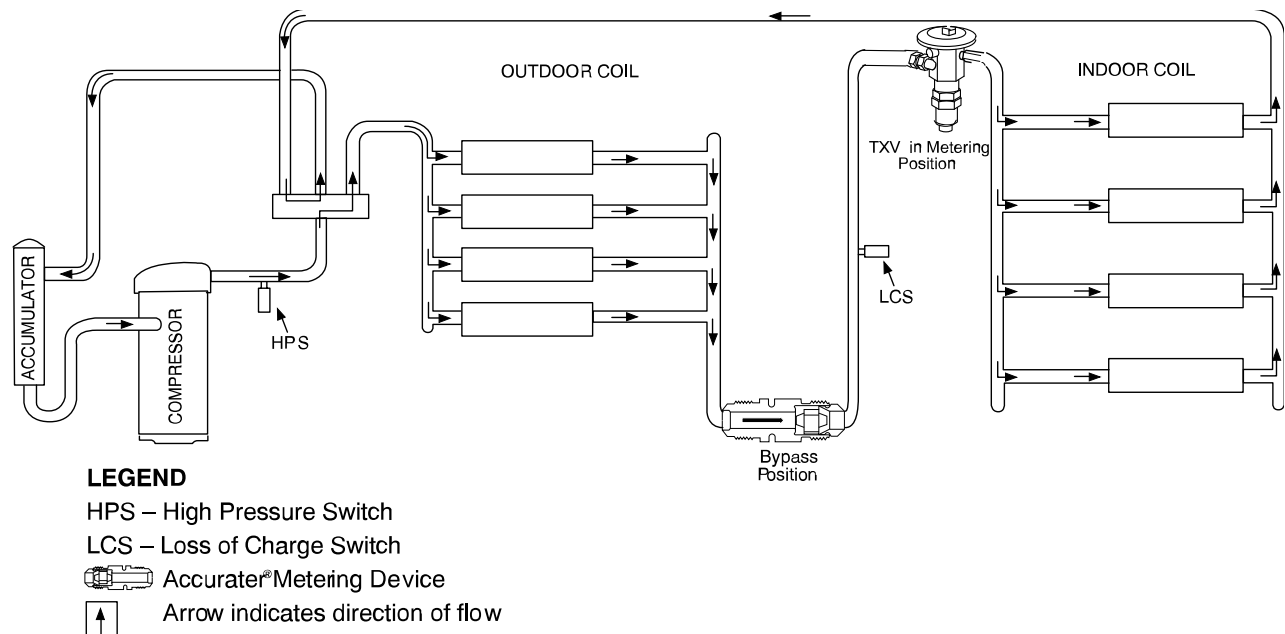

**Fig. 18 – Typical Heat Pump Operation, Cooling Mode**



**Table 4 – Dry Coil Air Delivery\* - Horizontal and Downflow Discharge Sizes 24-60**

Unit Size	Motor Speed	Tap	ESP (in. W.C.)										
			0.1	0.2	0.3	0.4	0.5	0.6	0.7	0.8	0.9	1	
24	Low	Blue	CFM	723	563	308	---	---	---	---	---	---	---
			BHP	0.09	0.07	0.06	---	---	---	---	---	---	---
	Med-Low	Pink	CFM	829	766	696	606	538	470	406	341	283	220
			BHP	0.11	0.12	0.12	0.13	0.13	0.14	0.14	0.15	0.15	0.16
	Medium**	Red	CFM	1065	1016	966	914	857	783	716	667	617	566
			BHP	0.19	0.20	0.20	0.21	0.22	0.23	0.23	0.24	0.24	0.25
	Med-High	Orange	CFM	1097	1048	999	949	893	833	751	701	651	603
			BHP	0.21	0.21	0.22	0.22	0.23	0.24	0.25	0.25	0.26	0.26
	High	Black	CFM	1215	1173	1129	1085	1038	989	936	854	803	760
			BHP	0.26	0.27	0.28	0.28	0.29	0.30	0.31	0.32	0.32	0.33
30	Low	Blue	CFM	643	552	455	348	225	---	---	---	---	---
			BHP	0.09	0.10	0.11	0.11	0.11	---	---	---	---	---
	Med-Low	Pink	CFM	817	744	673	597	516	431	325	190	---	---
			BHP	0.14	0.15	0.15	0.16	0.17	0.17	0.18	0.18	---	---
	Medium	Red	CFM	1159	1104	1045	990	937	878	821	759	693	618
			BHP	0.31	0.32	0.33	0.33	0.34	0.35	0.36	0.37	0.37	0.38
	Med-High**	Orange	CFM	1201	1147	1095	1037	987	934	877	818	755	671
			BHP	0.34	0.35	0.36	0.37	0.37	0.38	0.39	0.40	0.41	0.40
	High	Black	CFM	1291	1236	1181	1131	1080	1033	978	909	792	661
			BHP	0.41	0.42	0.43	0.43	0.44	0.45	0.46	0.45	0.43	0.40
36	Low	Blue	CFM	1069	1006	955	896	847	800	755	700	649	598
			BHP	0.16	0.17	0.18	0.19	0.20	0.21	0.22	0.23	0.24	0.24
	Med-Low	Pink	CFM	1154	1100	1045	997	936	886	847	804	749	699
			BHP	0.19	0.20	0.21	0.23	0.24	0.24	0.25	0.26	0.27	0.28
	Medium	Red	CFM	1295	1247	1199	1152	1104	1050	997	955	918	875
			BHP	0.26	0.27	0.28	0.29	0.30	0.31	0.32	0.33	0.33	0.34
	Med-High**	Orange	CFM	1421	1374	1328	1283	1236	1188	1137	1089	1042	1011
			BHP	0.32	0.33	0.35	0.36	0.37	0.38	0.39	0.40	0.41	0.41
	High	Black	CFM	1505	1464	1423	1380	1336	1292	1242	1199	1145	1096
			BHP	0.38	0.39	0.40	0.42	0.43	0.43	0.44	0.45	0.46	0.47
42	Low	Blue	CFM	956	899	843	786	729	676	621	558	504	435
			BHP	0.13	0.13	0.14	0.15	0.16	0.16	0.17	0.18	0.18	0.19
	Med-Low	Pink	CFM	1201	1153	1107	1060	1012	965	917	871	828	782
			BHP	0.21	0.22	0.22	0.23	0.24	0.25	0.26	0.27	0.28	0.29
	Medium	Red	CFM	1443	1402	1361	1322	1284	1243	1204	1164	1124	1084
			BHP	0.32	0.33	0.34	0.35	0.36	0.37	0.38	0.39	0.40	0.42
	Med-High**	Orange	CFM	1529	1491	1451	1411	1376	1338	1300	1261	1223	1185
			BHP	0.37	0.39	0.40	0.41	0.42	0.43	0.44	0.45	0.46	0.47
	High	Black	CFM	1604	1565	1529	1490	1455	1421	1385	1348	1310	1274
			BHP	0.42	0.44	0.45	0.46	0.47	0.48	0.49	0.50	0.51	0.52
48	Low	Blue	CFM	641	551	462	385	289	216	163	115	---	---
			BHP	0.05	0.06	0.06	0.07	0.07	0.08	0.08	0.09	---	---
	Med-Low	Pink	CFM	1437	1395	1351	1307	1265	1221	1176	1132	1084	1039
			BHP	0.29	0.30	0.31	0.32	0.33	0.34	0.35	0.36	0.37	0.38
	Medium**	Red	CFM	1771	1735	1699	1664	1627	1592	1557	1522	1486	1450
			BHP	0.51	0.52	0.53	0.55	0.56	0.57	0.58	0.59	0.61	0.62
	Med-High	Orange	CFM	1928	1897	1862	1830	1796	1764	1732	1698	1620	1512
			BHP	0.64	0.65	0.67	0.68	0.69	0.71	0.72	0.73	0.71	0.66
	High	Black	CFM	2212	2167	2124	2061	1976	1892	1794	1699	1567	1438
			BHP	0.97	0.99	1.00	0.97	0.95	0.91	0.86	0.82	0.77	0.71
60	Low	Blue	CFM	641	551	462	385	289	216	163	115	---	---
			BHP	0.05	0.06	0.06	0.07	0.07	0.08	0.08	0.09	---	---
	Med-Low	Pink	CFM	1437	1395	1351	1307	1265	1221	1176	1132	1084	1039
			BHP	0.29	0.30	0.31	0.32	0.33	0.34	0.35	0.36	0.37	0.38
	Medium**	Red	CFM	1914	1881	1848	1814	1780	1748	1716	1681	1619	1512
			BHP	0.62	0.64	0.65	0.67	0.68	0.69	0.71	0.72	0.71	0.66
	Med-High	Orange	CFM	1928	1897	1862	1830	1796	1764	1732	1698	1620	1512
			BHP	0.64	0.65	0.67	0.68	0.69	0.71	0.72	0.73	0.71	0.66
	High	Black	CFM	2212	2167	2124	2061	1976	1892	1794	1699	1567	1438
			BHP	0.97	0.99	1.00	0.97	0.95	0.91	0.86	0.82	0.77	0.71

Shaded areas indicate speed/static combinations that are not permitted for dehumidification speed.

\*Air delivery values are without air filter and are for dry coil (See Wet Coil Pressure Drop table).

\*\*Factory-shipped cooling speed

NOTE: Duct field-supplied air filter pressure drop and wet coil pressure drop to obtain static pressure available for ducting.

**Table 5 – Filter Pressure Drop Table (IN. W.C.)**

Filter Size in. (mm)	Cooling Tons	Standard CFM (SCFM)																
		600	700	800	900	1000	1100	1200	1300	1400	1500	1600	1700	1800	1900	2000	2100	2200
600-1400 CFM 12x20x1+12x20x1 (305x508x25+305x508x25)	2.0, 2.5	0.03	0.04	0.05	0.06	0.06	0.07	0.07	0.08	0.08	-	-	-	-	-	-	-	-

**Table 5 – Filter Pressure Drop Table (IN. W.C.)**

1200-1800CFM 16x24x1+14x24x1 (406x610x25+356x610x25)	3.0, 3.5, 4.0	-	-	-	-	0.04	0.05	0.06	0.07	0.08	0.09	0.09	0.10	0.11	0.12	0.12	-	-
1500-2200CFM 16x24x1+18x24x1 (406x610x25+457x610x25)	5.0	-	-	-	-	-	-	-	-	-	0.04	0.06	0.08	0.10	0.11	0.13	0.14	0.15

**Table 6 – Wet Coil Pressure Drop (IN. W.C.)**

Unit Size	Standard CFM (SCFM)																	
	600	700	800	900	1000	1100	1200	1300	1400	1500	1600	1700	1800	1900	2000	2100	2200	
24	0.03	0.04	0.04	0.05	0.06													
30				0.05	0.06	0.07	0.08	0.11										
36				0.06	0.06	0.09	0.10	0.11	0.14									
42					0.05	0.05	0.06	0.07	0.08	0.08	0.09	0.09	0.11					
48							0.04	0.06	0.09	0.10	0.10	0.11	0.12	0.13	0.14			
60										0.06	0.07	0.01	0.08	0.09	0.10	0.12	0.13	

**Table 7 – Economizer with 1-in. Filter Pressure Drop (IN. W.C.)**

Filter Size in. (mm)	Cooling Tons	Standard CFM (SCFM)																	
		600	700	800	900	1000	1100	1200	1300	1400	1500	1600	1700	1800	1900	2000	2100	2200	
600-1400 CFM 12x20x1+12x20x1 (305x508x25+305x508x25)	2.0, 2.5	-	-	0.08	0.09	0.10	0.11	0.11	0.13	0.14	-	-	-	-	-	-	-	-	
1200-1800CFM 16x24x1+14x24x1 (406x610x25+356x610x25)	3.0, 3.5, 4.0	-	-	-	-	-	0.09	0.09	0.10	0.12	0.13	0.15	0.17	0.17	0.19	0.21	-	-	
1500-2200CFM 16x24x1+18x24x1 (406x610x25+457x610x25)	5.0	-	-	-	-	-	-	-	-	-	0.15	0.17	0.18	0.20	0.21	0.22	0.23	0.23	

**Table 8 – Electric Heat Pressure Drop Table (in. W.C.)  
Small Cabinet: 24-30**

STATIC	STANDARD CFM (SCFM)												
	500	600	700	800	900	1000	1100	1200	1300	1400	1500	1600	
5kw	0.00	0.00	0.00	0.00	0.00	0.00	0.00	0.00	0.02	0.04	0.06	0.07	
7.5 kw	0.00	0.00	0.00	0.00	0.00	0.00	0.02	0.03	0.05	0.07	0.08	0.09	
10 kw	0.00	0.00	0.00	0.00	0.00	0.02	0.04	0.06	0.07	0.09	0.10	0.11	
15 kw	0.00	0.00	0.00	0.02	0.04	0.06	0.08	0.10	0.12	0.14	0.16	0.18	
20 kw	0.00	0.00	0.02	0.04	0.06	0.08	0.09	0.11	0.13	0.15	0.17	0.19	

**Electric Heat Pressure Drop Table (in. W.C.)  
Large Cabinet 36-60**

STATIC	STANDARD CFM (SCFM)														
	1100	1200	1300	1400	1500	1600	1700	1800	1900	2000	2100	2200	2300	2400	2500
5kw	0.00	0.00	0.00	0.01	0.02	0.03	0.04	0.05	0.06	0.07	0.08	0.09	0.10	0.11	0.12
7.5 kw	0.00	0.00	0.01	0.02	0.03	0.04	0.05	0.06	0.07	0.08	0.09	0.10	0.11	0.12	0.13
10 kw	0.00	0.00	0.01	0.02	0.03	0.04	0.05	0.06	0.07	0.08	0.09	0.10	0.11	0.12	0.13
15 kw	0.00	0.02	0.03	0.04	0.05	0.06	0.07	0.08	0.09	0.10	0.11	0.12	0.13	0.14	0.15
20 kw	0.02	0.03	0.04	0.05	0.06	0.07	0.08	0.09	0.10	0.11	0.12	0.13	0.14	0.15	0.16

## Maintenance

To ensure continuing high performance, and to minimize the possibility of premature equipment failure, periodic maintenance must be performed on this equipment. This heat pump unit should be inspected at least once each year by a qualified service person. To troubleshoot unit, refer to [Table 9](#).

**NOTE:** TO EQUIPMENT OWNER: Consult your local dealer about the availability of a maintenance contract.

### WARNING

#### PERSONAL INJURY AND UNIT DAMAGE HAZARD

Failure to follow this warning could result in personal injury or death and unit component damage.

The ability to properly perform maintenance on this equipment requires certain expertise, mechanical skills, tools and equipment. If you do not possess these, do not attempt to perform any maintenance on this equipment, other than those procedures recommended in the Owner's Manual.

### WARNING

#### ELECTRICAL SHOCK HAZARD

Failure to follow these warnings could result in personal injury or death:

1. Turn off electrical power to the unit and install a lockout tag before performing any maintenance or service on this unit.
2. Use extreme caution when removing panels and parts.
3. Never place anything combustible either on or in contact with the unit.

### CAUTION

#### UNIT OPERATION HAZARD

Failure to follow this caution may result in improper operation. Errors made when reconnecting wires may cause improper and dangerous operation. Label all wires prior to disconnecting when servicing.

The minimum maintenance requirements for this equipment are as follows:

1. Inspect air filter(s) each month. Clean or replace when necessary.
2. Inspect indoor coil, drain pan, and condensate drain each cooling season for cleanliness. Clean when necessary.
3. Inspect blower motor and wheel for cleanliness each cooling season. Clean when necessary.
4. Check electrical connections for tightness and controls for proper operation each cooling season. Service when necessary.

### Step 1 – Air Filter

**IMPORTANT:** Never operate the unit without a suitable air filter in the return-air duct system. Always replace the filter with the same dimensional size and type as originally installed. See [Table 1](#) for recommended filter sizes.

Inspect air filter(s) at least once each month and replace (throwaway-type) or clean (cleanable-type) at least twice during each cooling season and twice during the heating season, or whenever the filter becomes clogged with dust and lint.

## Indoor Blower and Motor

**NOTE:** All motors are pre-lubricated. Do not attempt to lubricate these motors.

**NOTE:** 460 volt units have a stepdown autotransformer that supplies approximately 230 volts to a nominal 230 volt indoor blower motor.

For longer life, operating economy, and continuing efficiency, clean accumulated dirt and grease from the blower wheel and motor annually.

### WARNING

#### ELECTRICAL SHOCK HAZARD

Failure to follow this warning could result in personal injury or death. Disconnect and tag electrical power to the unit before cleaning the blower motor and wheel.

To clean the blower motor and wheel:

1. Remove and disassemble blower assembly as follows:
  - a. Remove blower access panel (see [Fig. 23](#)).
  - b. Disconnect 5 pin plug and 4 pin plug from indoor blower motor. Remove capacitor if required.
  - c. On all units remove blower assembly from unit. Remove screws securing blower to blower partition and slide assembly out. Be careful not to tear insulation in blower compartment.
  - d. Ensure proper reassembly by marking blower wheel and motor in relation to blower housing before disassembly.
  - e. Loosen setscrew(s) that secures wheel to motor shaft, remove screws that secure motor mount brackets to housing, and slide motor and motor mount out of housing.
2. Remove and clean blower wheel as follows:
  - a. Ensure proper reassembly by marking wheel orientation.
  - b. Lift wheel from housing. When handling and/or cleaning blower wheel, be sure not to disturb balance weights (clips) on blower wheel vanes.
  - c. Remove caked-on dirt from wheel and housing with a brush. Remove lint and/or dirt accumulations from wheel and housing with vacuum cleaner, using soft brush attachment. Remove grease and oil with mild solvent.
  - d. Reassemble wheel into housing.
  - e. Reassemble motor into housing. Be sure setscrews are tightened on motor shaft flats and not on round part of shaft. Reinstall blower into unit. Reinstall capacitor.
  - f. Connect 5 pin plug and 4 pin plug to indoor blower motor.
  - g. Reinstall blower access panel (see [Fig. 23](#)).
3. Restore electrical power to unit. Start unit and check for proper blower rotation and motor speeds during cooling cycles.

SUPERHEAT CHARGING TABLE (SUPERHEAT °F (°C) AT COMPRESSOR SUCTION SERVICE PORT)														COOLING ONLY CHARGING PROCEDURE	
OUTDOOR TEMP °F (°C)	EVAPORATOR ENTERING AIR °F (°C) WB														
	50 (10)	52 (11)	54 (12)	56 (13)	58 (14)	60 (16)	62 (17)	64 (18)	66 (19)	68 (20)	70 (21)	72 (22)	74 (23)	76 (24)	<ol style="list-style-type: none"> <li>Operate unit a minimum of 10 minutes before checking charge.</li> <li>Measure suction pressure by attaching an accurate gauge to compressor suction side service port.</li> <li>Measure suction side temperature by attaching an accurate thermistor type or electronic thermometer to suction line about 10 inches from compressor.</li> <li>Measure outdoor air dry-bulb temperature with thermometer.</li> <li>Measure indoor air (return air) wet-bulb temperature with a sling psychrometer or electronic equivalent.</li> <li>Using Superheat Charging Table find outdoor temperature and indoor air wet-bulb temperature. At this intersection note superheat. Where a dash (-) appears on table do not attempt to charge unit under these conditions or refrigerant slugging may occur. In this situation refrigerant must be evacuated and weighed in. See rating plate for charge quantity.</li> <li>Refer to Required Suction Tube Temp. table. Find superheat temperature located in step 6 and suction pressure. At this intersection note suction line temperature.</li> <li>If unit has a higher suction line temperature than charted temperature, add refrigerant until charted temperature is reached.</li> <li>If unit has a lower suction line temperature than charted temperature, reclaim refrigerant until charted temperature is reached.</li> <li>If outdoor air temperature or pressure at suction port changes, charge to new suction line temperature indicated on chart.</li> </ol>
55 (12.7)	9 (5.0)	12 (6.7)	14 (7.8)	17 (9.4)	20 (11)	23 (13)	26 (14)	29 (16)	32 (18)	35 (19)	37 (21)	40 (22)	42 (23)	45 (25)	
60 (15.6)	7 (3.9)	10 (5.6)	12 (6.7)	15 (8.3)	18 (10)	21 (12)	24 (13)	27 (15)	30 (17)	33 (18)	35 (19)	38 (21)	40 (22)	43 (24)	
65 (18.3)	-	6 (3.3)	10 (5.6)	13 (7.2)	16 (8.9)	19 (11)	21 (12)	24 (13)	27 (15)	30 (17)	33 (18)	36 (20)	38 (21)	41 (23)	
70 (21.1)	-	-	7 (3.9)	10 (5.6)	13 (7.2)	16 (8.9)	19 (11)	21 (12)	24 (13)	27 (15)	30 (17)	33 (18)	36 (20)	39 (22)	
75 (23.9)	-	-	-	6 (3.3)	9 (5.0)	12 (6.7)	15 (8.3)	18 (10)	21 (12)	24 (13)	28 (16)	31 (17)	34 (19)	37 (21)	
80 (26.7)	-	-	-	-	5 (2.8)	8 (4.4)	12 (6.7)	15 (8.3)	18 (10)	21 (12)	25 (14)	28 (16)	31 (17)	35 (19)	
85 (29.4)	-	-	-	-	-	8 (4.4)	11 (6.1)	15 (8.3)	19 (11)	22 (12)	26 (14)	30 (17)	33 (18)	37 (21)	
90 (32.2)	-	-	-	-	-	-	5 (2.8)	9 (5.0)	13 (7.2)	16 (8.9)	20 (11)	24 (13)	27 (15)	31 (17)	
95 (35.0)	-	-	-	-	-	-	-	6 (3.3)	10 (5.6)	14 (7.8)	18 (10)	22 (12)	25 (14)	29 (16)	
100 (37.7)	-	-	-	-	-	-	-	-	8 (4.4)	12 (6.7)	16 (8.9)	20 (11)	23 (13)	27 (15)	
105 (40.6)	-	-	-	-	-	-	-	-	5 (2.8)	9 (5.0)	13 (7.2)	17 (9.4)	22 (12)	26 (14)	
110 (43.3)	-	-	-	-	-	-	-	-	-	6 (3.3)	11 (6.1)	15 (8.3)	20 (11)	25 (14)	
115 (46.1)	-	-	-	-	-	-	-	-	-	-	8 (4.4)	14 (7.8)	18 (10)	23 (13)	

REQUIRED SUCTION TUBE TEMPERATURE °F (°C) (MEASURED AT COMPRESSOR SUCTION SERVICE PORT)														
SUPERHEAT TEMP °F (°C)	SUCTION PRESSURE AT SUCTION SERVICE PORT PSIG (kPa)													
		107 (738)	111 (766)	116 (800)	120 (828)	125 (862)	130 (897)	135 (931)	140 (966)	145 (1000)				
0 (0)	35 (1.7)	37 (2.8)	39 (3.9)	41 (5.0)	43 (6.1)	45 (7.2)	47 (8.3)	49 (9.4)	51 (11)					
2 (1.1)	37 (2.8)	39 (3.9)	41 (5.0)	43 (6.1)	45 (7.2)	47 (8.3)	49 (9.4)	51 (11)	53 (12)					
4 (2.2)	39 (3.9)	41 (5.0)	43 (6.1)	45 (7.2)	47 (8.3)	49 (9.4)	51 (11)	53 (12)	55 (13)					
6 (3.3)	41 (5.0)	43 (6.1)	45 (7.2)	47 (8.3)	49 (9.4)	51 (11)	53 (12)	55 (13)	57 (14)					
8 (4.4)	43 (6.1)	45 (7.2)	47 (8.3)	49 (9.4)	51 (11)	53 (12)	55 (13)	57 (14)	59 (15)					
10 (5.6)	45 (7.2)	47 (8.3)	49 (9.4)	51 (11)	53 (12)	55 (13)	57 (14)	59 (15)	61 (16)					
12 (6.7)	47 (8.3)	49 (9.4)	51 (11)	53 (12)	55 (13)	57 (14)	59 (15)	61 (16)	63 (17)					
14 (7.8)	49 (9.4)	51 (11)	53 (12)	55 (13)	57 (14)	59 (15)	61 (16)	63 (17)	65 (18)					
16 (8.9)	51 (11)	53 (12)	55 (13)	57 (14)	59 (15)	61 (16)	63 (17)	65 (18)	67 (19)					
18 (10.0)	53 (12)	55 (13)	57 (14)	59 (15)	61 (16)	63 (17)	65 (18)	67 (19)	69 (21)					
20 (11.1)	55 (13)	57 (14)	59 (15)	61 (16)	63 (17)	65 (18)	67 (19)	69 (21)	71 (22)					
22 (12.2)	57 (14)	59 (15)	61 (16)	63 (17)	65 (18)	67 (19)	69 (21)	71 (22)	73 (23)					
24 (13.3)	59 (15)	61 (16)	63 (17)	65 (18)	67 (19)	69 (21)	71 (22)	73 (23)	75 (24)					
26 (14.4)	61 (16)	63 (17)	65 (18)	67 (19)	69 (21)	71 (22)	73 (23)	75 (24)	77 (25)					
28 (15.6)	63 (17)	65 (18)	67 (19)	69 (21)	71 (22)	73 (23)	75 (24)	77 (25)	79 (26)					
30 (16.7)	65 (18)	67 (19)	69 (21)	71 (22)	73 (23)	75 (24)	77 (25)	79 (26)	81 (27)					
32 (17.8)	67 (19)	69 (21)	71 (22)	73 (23)	75 (24)	77 (25)	79 (26)	81 (27)	83 (28)					
34 (18.9)	69 (21)	71 (22)	73 (23)	75 (24)	79 (26)	81 (27)	83 (28)	85 (29)	87 (31)					
36 (20.0)	71 (22)	73 (23)	75 (24)	81 (27)	83 (28)	85 (29)	87 (31)	89 (32)	91 (33)					
38 (21.1)	73 (23)	75 (24)	83 (28)	85 (29)	87 (31)	89 (32)	91 (33)							
40 (22.2)	75 (24)	85 (29)	85 (29)	85 (29)	85 (29)	85 (29)	87 (31)	89 (32)	91 (33)					

Superheat charging table is derived from optimum performance point. (95°F [35°C] outdoor ambient and (80°F [27°C] dry bulb; 67°F [19°C] wet bulb indoor condition.) Where a dash(-) appears do not attempt to check charge or charge unit under these conditions using the superheat method. (Weigh in method should be used.)

A150625

Model Size	Required Subcooling °F(°C)					Required Liquid Line Temperature for a Specific Subcooling (R-410A)											
	Outdoor Ambient Temperature °F(°C)					Pressure (psig)	Required Subcooling (°F)					Pressure (kPa)	Required Subcooling (°C)				
	75 (24)	85 (29)	95 (35)	105 (41)	115 (46)		5	10	15	20	25		3	6	8	11	14
024	10 (5.3)	9 (5.1)	9 (4.9)	9 (4.8)	8 (4.6)	189	61	56	51	46	41	1303	16	13	11	8	5
030	13 (7.1)	13 (6.9)	12 (6.8)	12 (6.5)	12 (6.4)	196	63	58	53	48	43	1351	17	15	12	9	6
036	12 (6.4)	12 (6.4)	11 (6.3)	11 (6.3)	11 (6.2)	203	66	61	56	51	46	1399	19	16	13	10	8
042	15 (8.3)	15 (8.3)	15 (8.2)	15 (8.2)	15 (8.1)	210	68	63	58	53	48	1448	20	17	14	11	9
048	-	-	-	-	-	217	70	65	60	55	50	1496	21	18	15	13	10
060	12 (6.6)	12 (6.6)	12 (6.6)	12 (6.6)	12 (6.6)	224	72	67	62	57	52	1544	22	19	16	14	11
						231	74	69	64	59	54	1593	23	20	18	15	12
						238	76	71	66	61	56	1641	24	21	19	16	13
						245	77	72	67	62	57	1689	25	22	20	17	14
						252	79	74	69	64	59	1737	26	23	21	18	15
						260	81	76	71	66	61	1792	27	25	22	19	16
						268	83	78	73	68	63	1848	29	26	23	20	17
						276	85	80	75	70	65	1903	30	27	24	21	19
						284	87	82	77	72	67	1958	31	28	25	22	20
						292	89	84	79	74	69	2013	32	29	26	23	21
						300	91	86	81	76	71	2068	33	30	27	24	22
						309	93	88	83	78	73	2130	34	31	28	26	23
						318	95	90	85	80	75	2192	35	32	29	27	24
						327	97	92	87	82	77	2254	36	33	31	28	25
						336	99	94	89	84	79	2316	37	34	32	29	26
						345	101	96	91	86	81	2378	38	35	33	30	27
						354	103	98	93	88	83	2440	39	36	34	31	28
						364	105	100	95	90	85	2509	40	38	35	32	29
						374	107	102	97	92	87	2578	41	39	36	33	30
						384	108	103	98	93	88	2647	42	40	37	34	31
						394	110	105	100	95	90	2716	44	41	38	35	32
						404	112	107	102	97	92	2785	45	42	39	36	33
						414	114	109	104	99	94	2854	46	43	40	37	34
						424	116	111	106	101	96	2923	47	44	41	38	35
						434	118	113	108	103	98	2992	48	45	42	39	36
						444	119	114	109	104	99	3061	49	46	43	40	37
						454	121	116	111	106	101	3130	49	47	44	41	38
						464	123	118	113	108	103	3199	50	48	45	42	39
						474	124	119	114	109	104	3268	51	48	46	43	40
						484	126	121	116	111	106	3337	52	49	47	44	41
						494	127	122	117	112	107	3406	53	50	47	45	42
						504	129	124	119	114	109	3475	54	51	48	46	43
						514	131	126	121	116	111	3544	55	52	49	46	44
						524	132	127	122	117	112	3612	56	53	50	47	45
						534	134	129	124	119	114	3681	56	54	51	48	45

To properly check or adjust charge, conditions must be favorable for subcooling charging. Favorable conditions exist when the outdoor temperature is between 75°F to 115°F (24°C and 46°C), and the indoor temperature is between 70°F and 80°F (21°C and 27°C). Follow the procedure above.

Fig. 21 – Cooling Charging Table-Subcooling

A221504

## Step 2 – Outdoor Coil, Indoor Coil, and Condensate Drain Pan

Inspect the condenser coil, evaporator coil, and condensate drain pan at least once each year.

The coils are easily cleaned when dry; therefore, inspect and clean the coils either before or after each cooling season. Remove all obstructions, including weeds and shrubs, that interfere with the airflow through the condenser coil.

Straighten bent fins with a fin comb. If coated with dirt or lint, clean the coils with a vacuum cleaner, using the soft brush attachment. Be careful not to bend the fins. If coated with oil or grease, clean the coils with a mild detergent-and-water solution. Rinse coils with clear water, using a garden hose. Be careful not to splash water on motors, insulation, wiring, or air filter(s). For best results, spray condenser coil fins from inside to outside the unit. On units with an outer and inner condenser coil, be sure to clean between the coils. Be sure to flush all dirt and debris from the unit base.

Inspect the drain pan and condensate drain line when inspecting the coils. Clean the drain pan and condensate drain by removing all foreign matter from the pan. Flush the pan and drain trough with clear water. Do not splash water on the insulation, motor, wiring, or air filter(s). If the drain tube is restricted, clear it with a plumbers snake or similar probe device.

## Step 3 – Outdoor Fan

Keep the condenser fan free from all obstructions to ensure proper cooling operation. Never place articles on top of the unit. Damage to unit may result.

1. Remove 6 screws holding outdoor grille and motor to top cover.
2. Turn motor/grille assembly upside down on top cover to expose fan blade.
3. Inspect the fan blades for cracks or bends.
4. If fan needs to be removed, loosen setscrew and slide fan off motor shaft.
5. When replacing fan blade, position blade back to same position as before.
6. Ensure that setscrew engages the flat area on the motor shaft when tightening.
7. Replace grille.

## Step 4 – Electrical Controls and Wiring

Inspect and check the electrical controls and wiring annually. Be sure to turn off the electrical power to the unit.

Remove access panels (see Fig. 23 to locate all the electrical controls and wiring. Check all electrical connections for tightness. Tighten all screw connections. If any discolored or burned connections are noticed, disassemble the connection, clean all the parts, restrip the wire end and reassemble the connection properly and securely.

After inspecting the electrical controls and wiring, replace all the panels. Start the unit, and observe at least one complete cooling cycle to ensure proper operation. If discrepancies are observed in operating cycle, or if a suspected malfunction has occurred, check each electrical component with the proper electrical instrumentation. Refer to the unit wiring label when making these checkouts.

## Step 5 – Refrigerant Circuit

Inspect all refrigerant tubing connections.

If low performance is suspected, leak-test all refrigerant tubing using an electronic leak detector, or liquid-soap solution. If a refrigerant leak is detected, refer to Check for Refrigerant Leaks section.

If no refrigerant leaks are found and low performance is suspected, refer to Checking and Adjusting Refrigerant Charge section.

## Step 6 – Indoor Airflow

The heating and/or cooling airflow does not require checking unless improper performance is suspected. If a problem exists, be sure that all supply-air and return-air grilles are open and free from obstructions, and that the air filter is clean. When necessary, refer to Indoor Airflow and Airflow Adjustments section to check the system airflow.

## Step 7 – Metering Devices-TXV & Piston

This unit uses 2 types of metering devices. The outdoor metering device is a fixed orifice and is contained in the brass hex-body in each liquid line feeding the outdoor coils. The indoor metering device is a TXV type device.

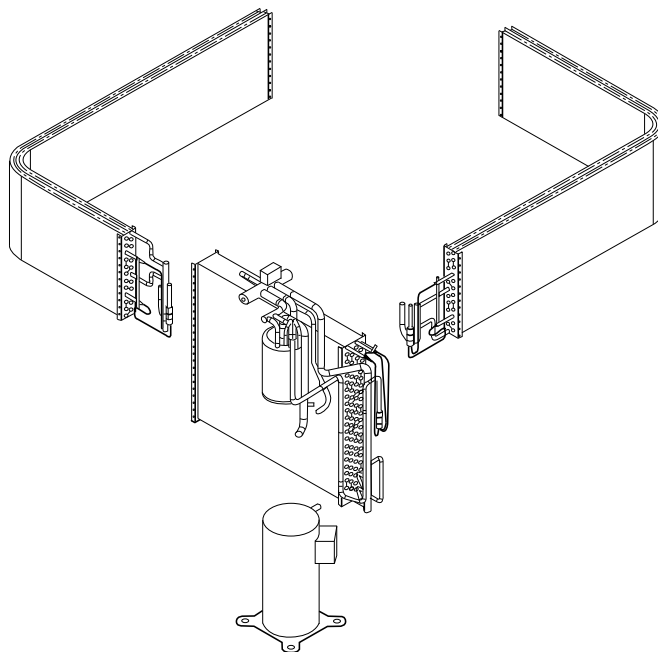

Fig. 22 – Refrigerant Circuit

C99097

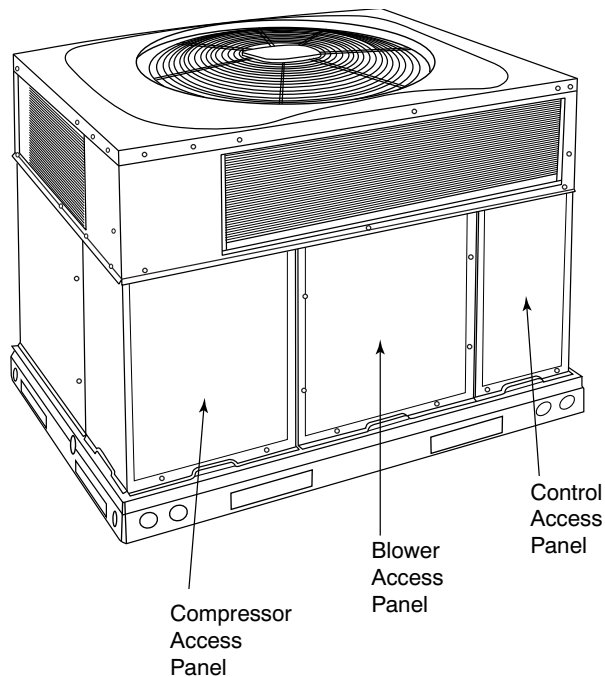

Fig. 23 – Unit Access Panels

A09215

## Step 8 – Pressure Switches

Pressure switches are protective devices wired into control circuit (low voltage). They shut off compressor if abnormally high or low pressures

are present in the refrigeration circuit. These pressure switches are specifically designed to operate with R-410A systems. R-22 pressure switches must not be used as replacements for the R-410A system.

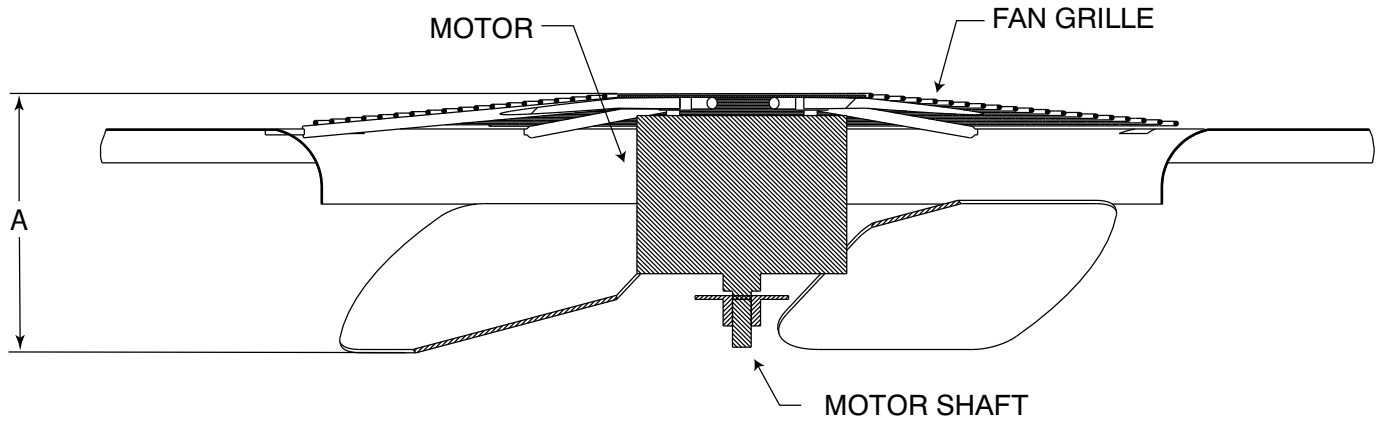

A08505

MAX DISTANCE BETWEEN TOP OF FAN GRILLE AND BOTTOM OF FAN BLADE

Size	"A"	
	IN.	mm
24	7.1	180
30	8.0	203
36	7.6	193
42	7.6	193
48	7.6	193
60	7.6	193

Fig. 24 – Fan Blade Position

**Step 9 – Loss of Charge Switch**

This switch is located on the liquid line and protects against low suction pressures caused by such events as loss of charge, low airflow across indoor coil, dirty filters, etc. It opens on a pressure drop at about 20 psig. If system pressure is above this, switch should be closed. To check switch:

1. Turn off all power to unit.
2. Disconnect leads on switch.
3. Apply ohm meter leads across switch. You should have continuity on a good switch.

**NOTE:** Because these switches are attached to refrigeration system under pressure, it is not advisable to remove this device for troubleshooting unless you are reasonably certain that a problem exists. If switch must be removed, remove and recover all system charge so that pressure gauges read 0 psig. Never open system without breaking vacuum with dry nitrogen.

**Step 10 – High-Pressure Switch**

The high-pressure switch is located in the discharge line and protects against excessive condenser coil pressure. It opens at 650 psig.

High pressure may be caused by a dirty outdoor coil, failed fan motor, or outdoor air recirculation.

To check switch:

1. Turn off all power to unit.
2. Disconnect leads on switch.
3. Apply ohm meter leads across switch. You should have continuity on a good switch.

**Step 11 – Copeland Scroll Compressor (R-410A Refrigerant)**

The compressor used in this product is specifically designed to operate with R-410A refrigerant and cannot be interchanged.

! **WARNING**

**EXPLOSION HAZARD**

Failure to follow this warning could result in personal injury, death or property damage. Wear safety glasses and gloves when handling refrigerants. Keep torches and other ignition sources away from refrigerant and oils.

The scroll compressor pumps refrigerant throughout the system by the interaction of a stationary and an orbiting scroll. The scroll compressor has no dynamic suction or discharge valves, and it is more tolerant of stresses caused by debris, liquid slugging, and flooded starts. The compressor is equipped with an internal pressure relief port. The pressure relief port is a safety device, designed to protect against extreme high pressure. The relief port has an operating range between 550 and 625 psig differential pressure.

**Step 12 – Refrigerant System**

This step covers the refrigerant system including the compressor oil needed, servicing systems on roofs containing synthetic materials, the filter drier and refrigerant charging.

**Refrigerant****PROPERTY HAZARD, PERSONAL INJURY OR ENVIRONMENTAL HAZARD**

Failure to follow this warning could result in property damage or personal injury or death.

This system uses R-410A refrigerant which has higher operating pressures than R-22 and other refrigerants. No other refrigerant may be used in this system. Gauge set, hoses, and recovery system must be designed to handle R-410A. If you are unsure consult the equipment manufacturer.

**Compressor Oil**

The Copeland scroll compressor uses 3MAF POE oil. If additional oil is needed, use Uniqema RL32-3MAF. If this oil is not available, use Copeland Ultra 32 CC or Mobil Arctic EAL22 CC. This oil is extremely hygroscopic, meaning it absorbs water readily. POE oils can absorb 15 times as much water as other oils designed to HCFC and CFC refrigerants. Take all necessary precautions to avoid exposure of the oil to the atmosphere.

**Servicing Systems on Roofs with Synthetic Materials**

POE (polyolester) compressor lubricants are known to cause long term damage to some synthetic roofing materials. Exposure, even if immediately cleaned up, may cause embrittlement (leading to cracking) to occur in one year or more. When performing any service that may risk exposure of compressor oil to the roof, take appropriate precautions to protect roofing. Procedures which risk oil leakage include, but are not limited to, compressor replacement, repairing refrigerant leaks, replacing refrigerant components such as filter drier, pressure switch, metering device, coil, accumulator, or reversing valve.

**Synthetic Roof Precautionary Procedure**

1. Cover extended roof working area with an impermeable polyethylene (plastic) drip cloth or tarp. Cover an approximate 10x10 ft (3x3 m) area.
2. Cover area in front of the unit service panel with a terry cloth shop towel to absorb lubricant spills and prevent run-offs, and protect drip cloth from tears caused by tools or components.
3. Place terry cloth shop towel inside unit immediately under component(s) to be serviced and prevent lubricant run-offs through the louvered openings in the unit base.
4. Perform required service.
5. Remove and dispose of any oil contaminated material per local codes.

**Liquid Line Filter Drier**

The biflow filter drier is specifically designed to operate with R-410A. Use only factory-authorized components. Filter drier must be replaced whenever the refrigerant system is opened. When removing a filter drier, use a tubing cutter to cut the drier from the system. Do not unsweat a filter drier from the system. Heat from unsweating will release moisture and contaminants from drier into system.

**R-410A Refrigerant Charging**

Refer to unit information plate and charging chart. Some R-410A refrigerant cylinders contain a dip tube to allow liquid refrigerant to flow from cylinder in upright position. For cylinders equipped with a dip tube, charge R-410A units with cylinder in upright position and a commercial metering device in manifold hose. Charge refrigerant into suction-line.

## Step 13 – System Information

### Loss of Charge Switch

The loss of charge switch is a protective device wired into control circuit (low voltage). It shuts off the compressor if abnormally low pressures are present in the refrigeration circuit.

**NOTE:** Because these switches are attached to refrigeration system under pressure, it is not advisable to remove this device for troubleshooting unless you are reasonably certain that a problem exists. If switch must be removed, remove and recover all system charge so that pressure gauges read 0 psig. Never open system without breaking vacuum with dry nitrogen.

### Check Defrost Thermostat

The defrost thermostat is usually located on the lowest liquid leaving circuit of the left condenser coil (see Fig. 25). The thermostat closes at 32°F (0°C) and opens at 65°F (18°C).

The defrost thermostat signals heat pump that conditions are right for defrost or that conditions have changed to terminate defrost. It is a thermally actuated switch clamped to outdoor coil to sense its temperature. Normal temperature range is closed at 32° ± 3°F (0 ± 1.7°C) and open at 65° ± 5°F (18 ± 2.8°C).

**NOTE:** The defrost thermostat must be located on the liquid side of the outdoor coil on the bottom circuit and as close to the coil as possible. The factor location is on the left/back coil.

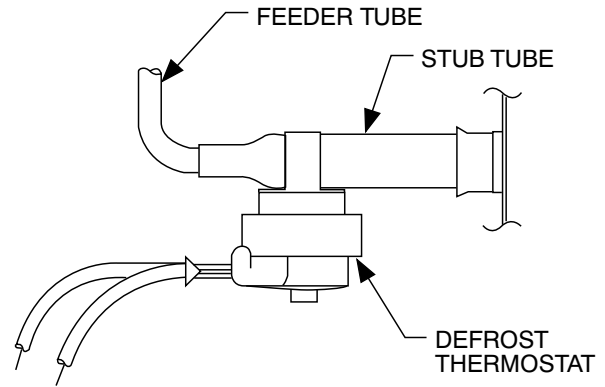

Fig. 25 – Defrost Thermostat

C99029

## Troubleshooting

Refer to the Cooling and Heating Troubleshooting Chart (Table 9) for troubleshooting information.

## Start-Up Checklist

Use the Start-Up Checklist.

Table 9 – Troubleshooting Chart

SYMPTOM	CAUSE	REMEDY
Compressor and condenser fan will not start.	Power failure	Call power company
	Fuse blown or circuit breaker tripped	Replace fuse or reset circuit breaker
	Defective contactor, transformer, or high-pressure, loss-of-charge or low-pressure switch	Replace component
	Insufficient line voltage	Determine cause and correct
	Incorrect or faulty wiring	Check wiring diagram and rewire correctly
	Thermostat setting too high	Lower thermostat setting below room temperature
Compressor will not start but condenser fan runs	Faulty wiring or loose connections in compressor circuit	Check wiring and repair or replace
	Compressor motor burned out, seized, or internal overload open	Determine cause. Replace compressor.
	Defective run/start capacitor, overload, start relay	Determine cause and replace
	One leg of 3-phase power dead	Replace fuse or reset circuit breaker Determine cause
Three-phase scroll compressor makes excessive noise, and there may be a low pressure differential.	Scroll compressor is rotating in the wrong direction	Correct the direction of rotation by reversing the 3-phase power leads to the unit.
Compressor cycles (other than normally satisfying thermostat).	Refrigerant overcharge or undercharge	Recover refrigerant, evacuate system, and recharge to capacities shown on rating plate
	Defective compressor	Replace and determine cause
	Insufficient line voltage	Determine cause and correct
	Blocked condenser	Determine cause and correct
	Defective run/start capacitor, overload or start relay	Determine cause and replace
	Defective thermostat	Replace thermostat
	Faulty condenser-fan motor or capacitor	Replace
Restriction in refrigerant system	Locate restriction and remove	
Compressor operates continuously	Dirty air filter	Replace filter
	Unit undersized for load	Decrease load or increase unit size
	Thermostat set too low	Reset thermostat
	Low refrigerant charge	Locate leak, repair, and recharge
	Mechanical damage in compressor	Replace compressor
	Air in system	Recover refrigerant, evacuate system, and recharge
	Condenser coil dirty or restricted	Clean coil or remove restriction
Excessive head pressure	Dirty air filter	Replace filter
	Dirty condenser coil	Clean coil
	Refrigerant overcharged	Recover excess refrigerant
	Air in system	Recover refrigerant, evacuate system, and recharge
	Condenser air restricted or air short-cycling	Determine cause and correct
Head pressure too low	Low refrigerant charge	Check for leaks, repair, and recharge.
	Compressor IPR leaking	Replace compressor
	Restriction in liquid tube	Remove restriction
Excessive suction pressure	High heat load	Check for source and eliminate
	Compressor IPR leaking	Replace compressor
	Refrigerant overcharged	Recover excess refrigerant
Suction pressure too low	Dirty air filter	Replace filter
	Low refrigerant charge	Check for leaks, repair and recharge
	Metering device or low side restricted	Remove source of restriction
	Insufficient evaporator airflow	Increase air quantity Check filter—replace if necessary
	Temperature too low in conditioned area	Reset thermostat
	Outdoor ambient below 55°F (12.7°C)	Install low-ambient kit
Filter drier restricted	Replace filter	

# Start-Up Checklist

(Remove and Store in Job Files)

## I. PRELIMINARY INFORMATION

MODEL NO.: \_\_\_\_\_

SERIAL NO.: \_\_\_\_\_

DATE: \_\_\_\_\_

TECHNICIAN: \_\_\_\_\_

## II. PRESTART-UP (Insert check mark in box as each item is completed)

- ( ) VERIFY THAT ALL PACKING MATERIALS HAVE BEEN REMOVED FROM UNIT
- ( ) REMOVE ALL SHIPPING HOLD DOWN BOLTS AND BRACKETS PER INSTALLATION INSTRUCTIONS
- ( ) CHECK ALL ELECTRICAL CONNECTIONS AND TERMINALS FOR TIGHTNESS
- ( ) CHECK THAT INDOOR (EVAPORATOR) AIR FILTER IS CLEAN AND IN PLACE
- ( ) VERIFY THAT UNIT INSTALLATION IS LEVEL
- ( ) CHECK FAN WHEEL, AND PROPELLER FOR LOCATION IN HOUSING/ORIFICE AND SETSCREW TIGHTNESS
- ( ) INSPECT TUBING

## III. START-UP

### ELECTRICAL

SUPPLY VOLTAGE \_\_\_\_\_

COMPRESSOR AMPS \_\_\_\_\_

INDOOR (EVAPORATOR) FAN AMPS \_\_\_\_\_

### TEMPERATURES

OUTDOOR (CONDENSER) AIR TEMPERATURE \_\_\_\_\_ DB

RETURN-AIR TEMPERATURE \_\_\_\_\_ DB \_\_\_\_\_ WB

COOLING SUPPLY AIR \_\_\_\_\_ DB \_\_\_\_\_ WB

HEAT PUMP SUPPLY AIR \_\_\_\_\_

ELECTRICAL HEAT SUPPLY AIR \_\_\_\_\_

### PRESSURES

REFRIGERANT SUCTION \_\_\_\_\_ PSIG, SUCTION LINE TEMP\* \_\_\_\_\_

REFRIGERANT DISCHARGE \_\_\_\_\_ PSIG, LIQUID TEMP† \_\_\_\_\_

- ( ) VERIFY REFRIGERANT CHARGE USING CHARGING CHARTS

\* Measured at suction inlet to compressor

† Measured at liquid line leaving condenser.