

FAN COILS ACCESSORY ELECTRIC HEATERS

WIRING DIAGRAMS

FIG.	FIELD-INSTALLED HEATER MODEL	FB4C	FE4A/FE5A	FH4C	FV4C	FX4D	FY5B	PF4MA	PF4MB	LABEL
1	KFCEH0401N03A	18,24	x	001	x	19,25	18,24	18,19,24,25	x	340816-101
1	KFCEH0501N05A	18-60	002-006	001-002	002-006	19-61	18-60	18-61	19-61	340816-101
2	KFCEH0801N08A	18-60	002-006	001-003	002-006	19-61	18-60	18-61	19-61	340817-101
2	KFCEH0901N10A	18-60	002-006	001-004	002-006	19-61	18-60	18-61	19-61	340817-101
6	KFCEH1601315A	42-60	002-006	001-004	002-006	43-61	18-60	18-61	19-61	340819-101
7	KFCEH2001318A	42-60	003-006	001-004	002-006	43-61	42-60	42-61	37-61	340818-101
1	KFCEH2401C05A	18-60	002-006	001-002	002-006	19-61	18-60	18-61	19-61	340816-101
2	KFCEH2501C08A	18-60	002-006	001-003	002-006	19-61	18-60	18-61	19-61	340817-101
2	KFCEH2601C10A	18-60	002-006	001-004	002-006	19-61	18-60	18-61	19-61	340817-101
3	KFCEH2901N09A	36-60	002-006	003-004	002-006	37-61	36-60	36-60	31-61	340813-101
4	KFCEH3001F15A	24-60	002-006	001-004	002-006	25-61	24-60	24-61	19-61	340814-101
4	KFCEH3101C15A	24-60	002-006	001-004	002-006	25-61	24-60	24-61	19-61	340814-101
5	KFCEH3201F20A	30-60	002-006	002-004	002-006	31-61	30-60	30-61	19-61	340815-101
5	KFCEH3301C20A	30-60	002-006	002-004	002-006	31-61	30-60	30-61	19-61	340815-101
8,9	KFCEH3401F24A	48,60	004-006	003-004	005-006	49-61	48-60	48-61	49-61	340821-101, 340820-101
8,9	KFCEH3501F30A	48,60	004-006	003-004	005-006	49-61	48-60	48-61	49-61	340821-101 340820-101

FAN COIL WITH RBC X-13 MOTOR OR BROAD OCEAN DIGI MOTOR

FIG.	FACTORY-INSTALLED HEATER MODEL	FB4C	FX4D	LABEL
11	MKFCEH0501N05A	18,24	19,25	341018-101
10	MKFCEH0801N08A	18,30	31	341017-101
10	MKFCEH0901N10A	24-48	37-61	341017-101
12	MKFCEH3001F15A	36-60	61	341019-101

FAN COIL WITH COOLING ONLY CONTROL

FIG.	MODEL	SIZE	LABEL
13	FV4C	002-006	326014-101
14	FE4A/FE5A	002-006	333107-101
15	FY5B/PF4MNA	18-60	328964-101
15	FH4C	001-004	328964-101
16	FB4C/FX4D (RBC)	18-61	336228-101
16	PF4MNA/B	19,25,31,37,43,49,61	336228-101
17	FB4C/FX4D (BOM)	18-61	337519-101

ELECTRIC HEATERS

FIG.	HEATER MODEL	FF1E	LABEL
18	KFDEH0801D05A	18,24,30,36	341080-101
19	KFDEH0901D75A	18,24,30,36	341081-101
19	KFDEH1001D11A	18,24,30,36	341081-101
20	KFEEH0101D05A	19,25,31,37	341082-101
21	KFEEH0201D75A	19,25,31,37	341083-101
21	KFEEH0301D11A	19,25,31,37	341083-101

FIG.	HEATER MODEL	CONTROL TYPE	FFMA	LABEL
22	EHK2-05B	Sequencer - HS	18,24,30,36 Prior to serial number date code 1715V.	202070290385
22	EHK2-08B	Sequencer - HS	18,24,30,36 Prior to serial number date code 1715V.	202070290385
22	EHK2-10B	Sequencer - HS	18,24,30,36 Prior to serial number date code 1715V.	202070290385
23			18-37 Serial number date code 1715V and later.	2020702A717
24	EHK2-05B	Relay - HR	18-37	06-7094-02
24	EHK2-08B	Relay - HR	18-37	06-7094-02
24	EHK2-10B	Relay - HR	18-37	06-7094-02

FIG.	FFMA	LABEL
25	19,31	--
26	25,37	--

FIG.	FPM(A,B)N(C,U)	LABEL
27	ALL	202070290388 Valid for models FPM(A,B)N(C,U)0**000AAAA
27	FPMA with Time Delay Board	2020702A2016 Valid for models FPM(A,B)N(C,U)0**000ABAA

FIG.	HEATER MODEL	FPMAN(C,U)	FPMBN(C,U)	LABEL
28	EHK3-05B	18-36	18-30	06-7094-03
28	EHK3-08B	18-36	18-30	06-7094-03
28	EHK3-10B	18-36	18-30	06-7094-03

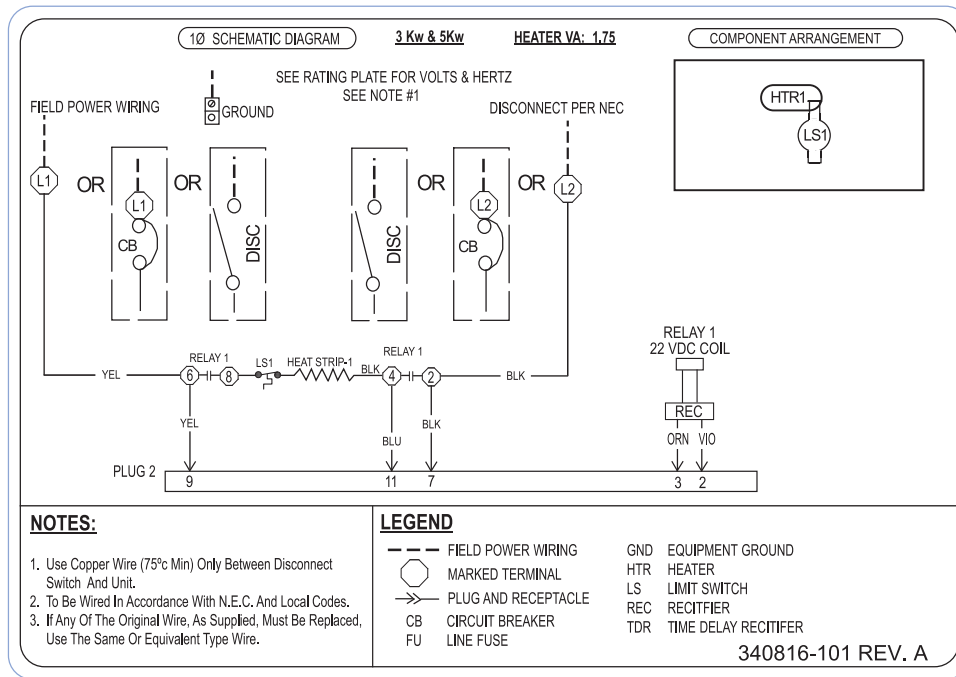

Fig. 1 - 340816-101

A150105

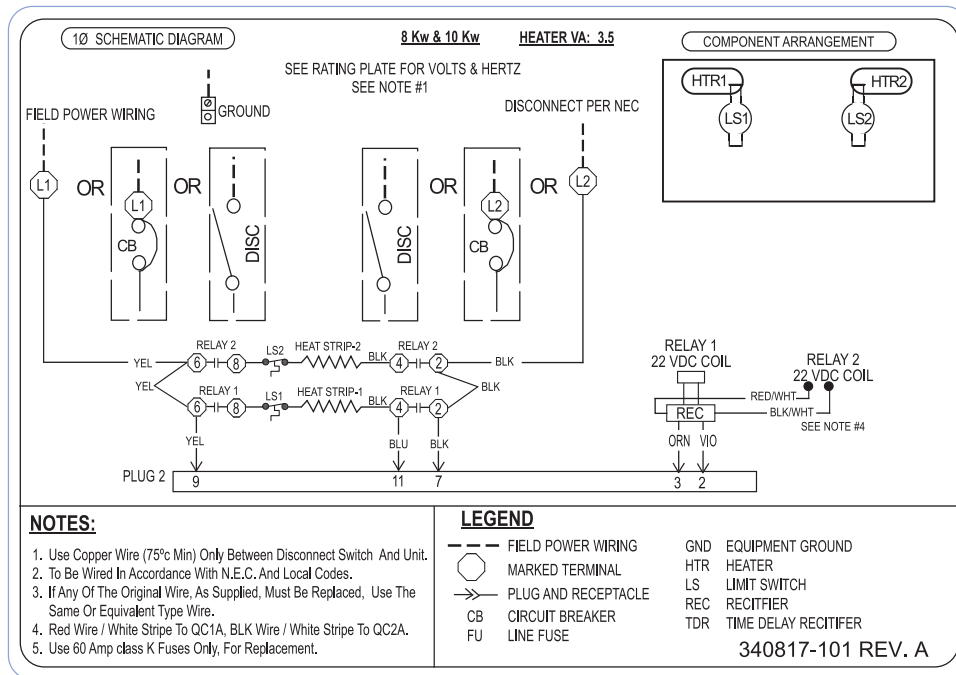

Fig. 2 - 340817-101

A150106

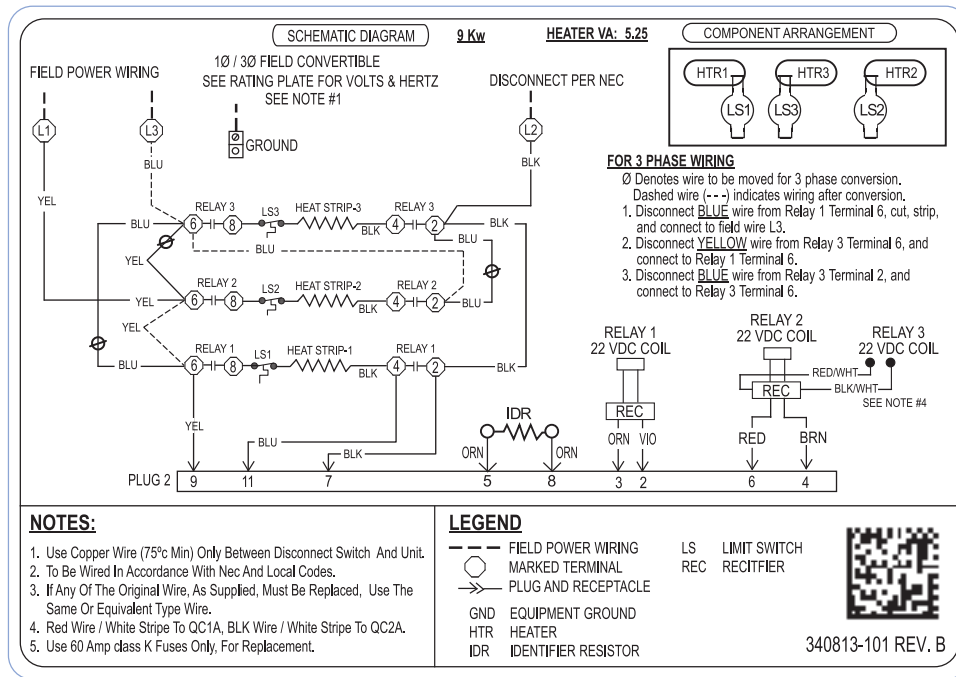

Fig. 3 - 340813-101

A150102

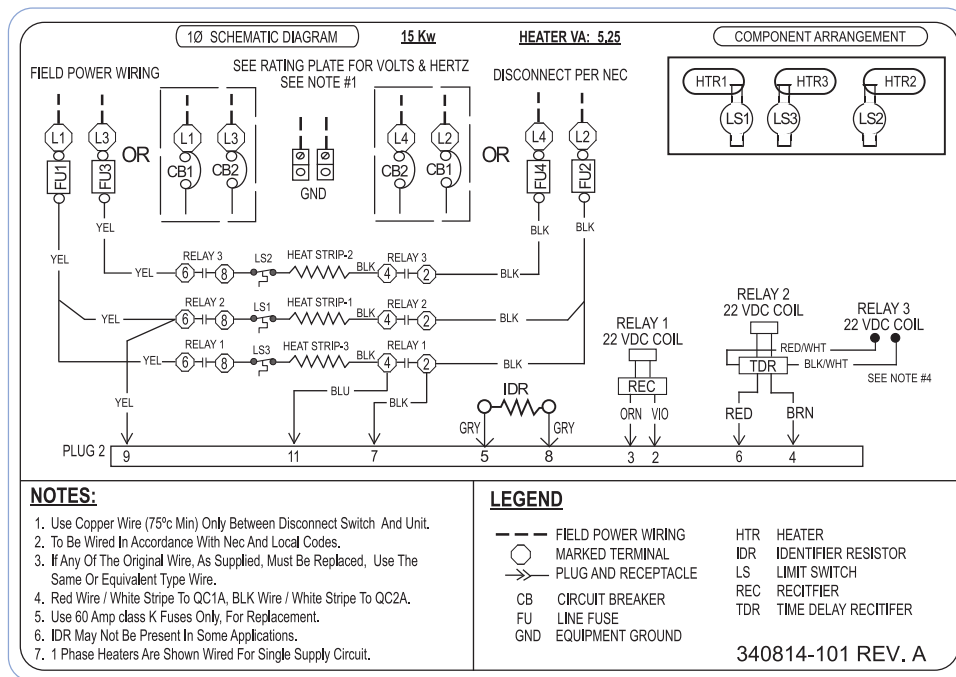

Fig. 4 - 340814-101

A150103

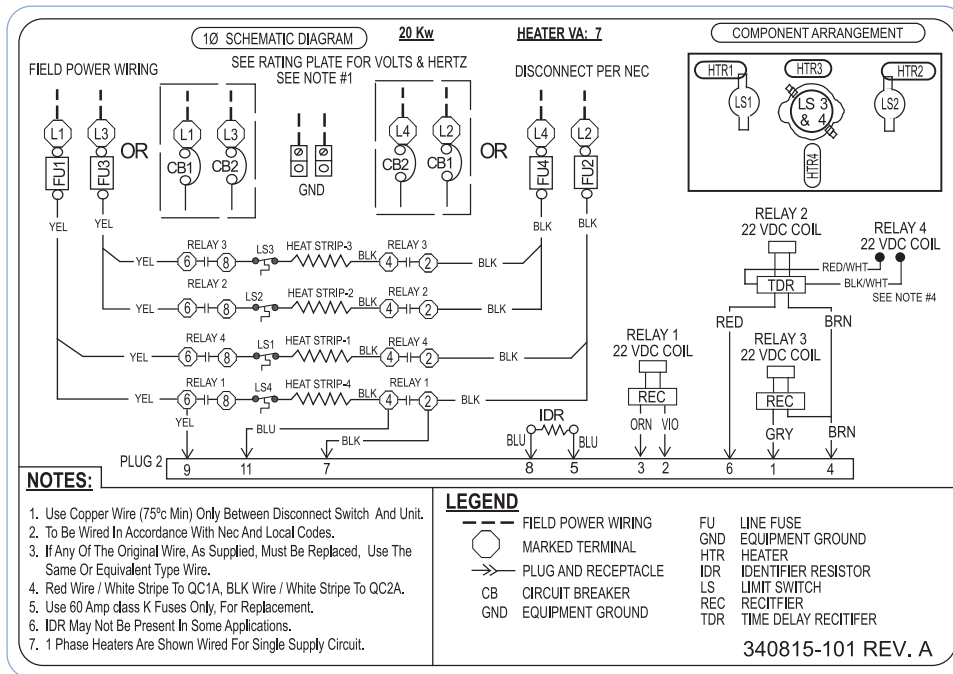

Fig. 5 - 340815-101

A150104

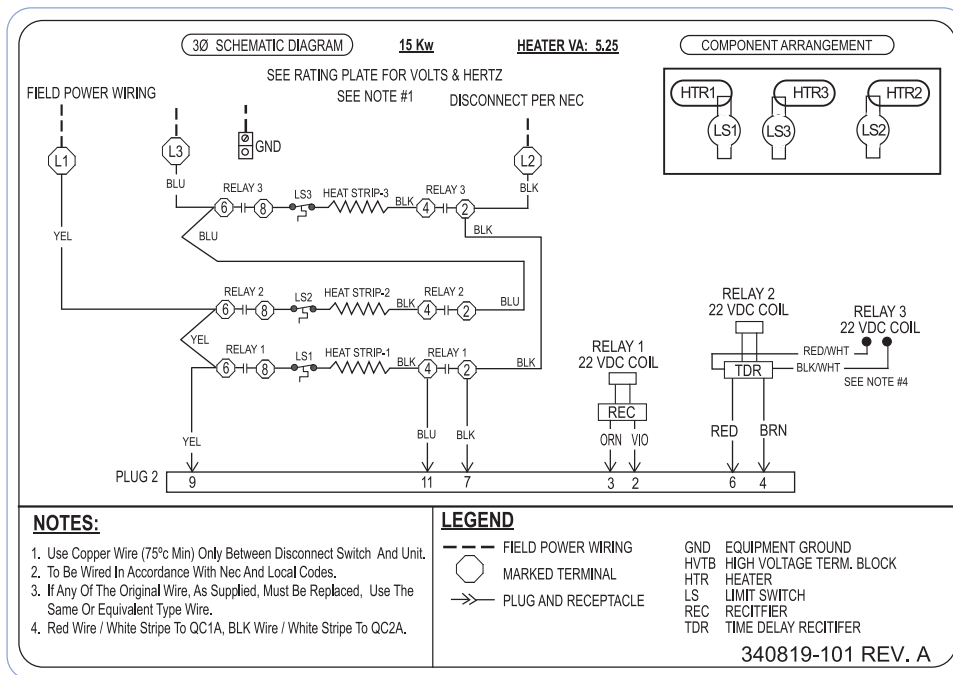

Fig. 6 - 340819-101

A150108

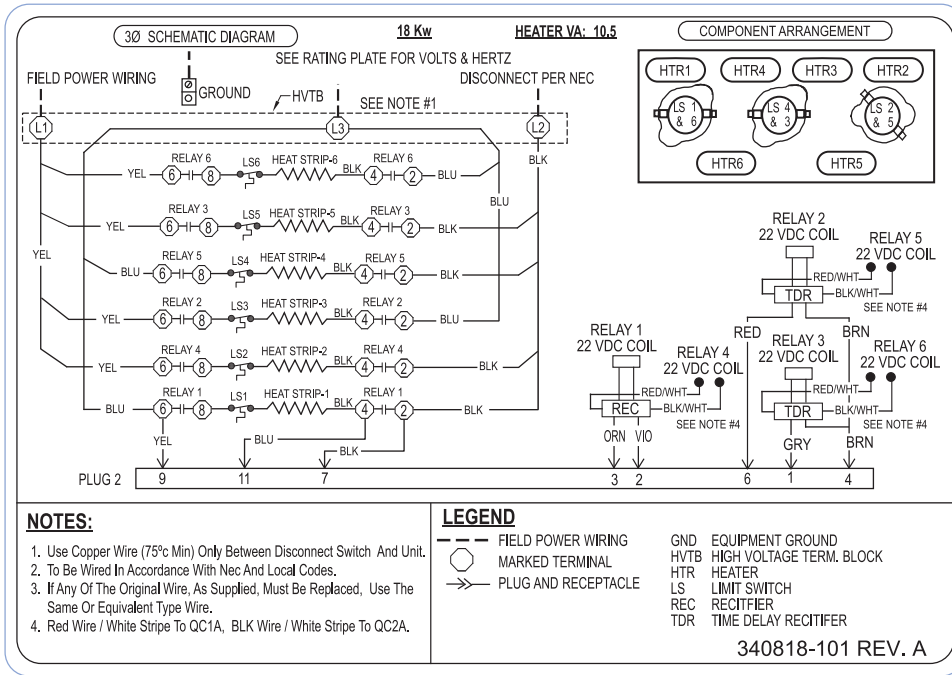

Fig. 7 - 340818-101

A150107

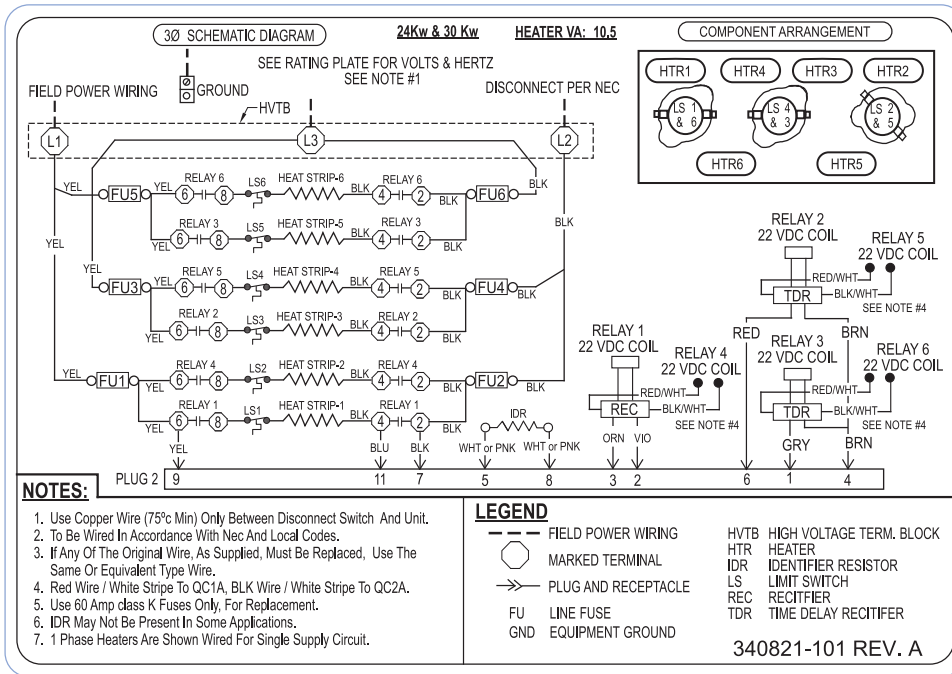

Fig. 8 - 340821-101

A150109

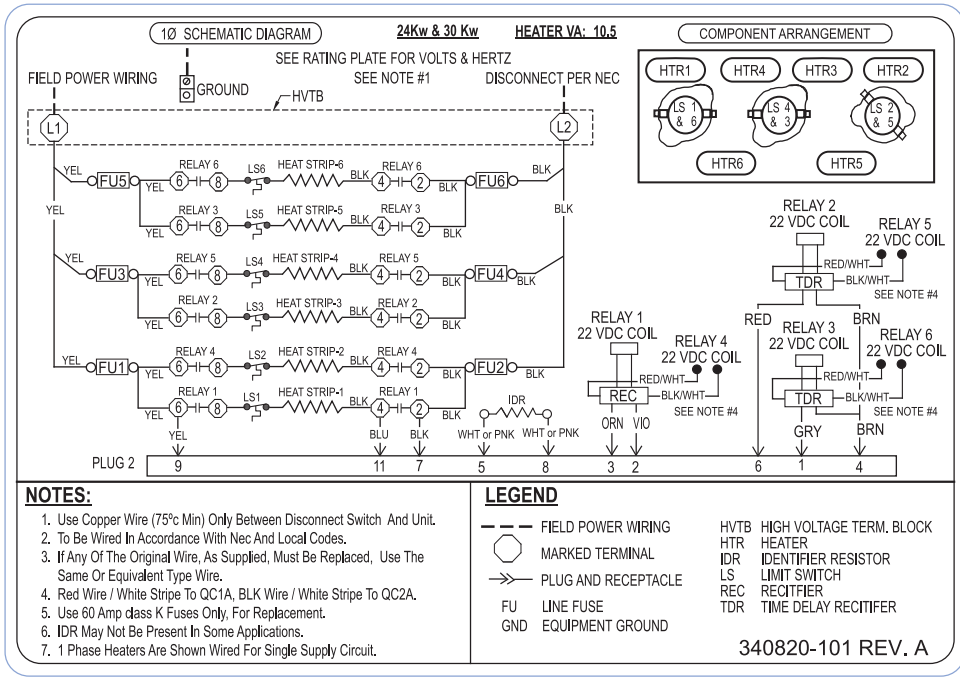

Fig. 9 - 340820-101

A150110

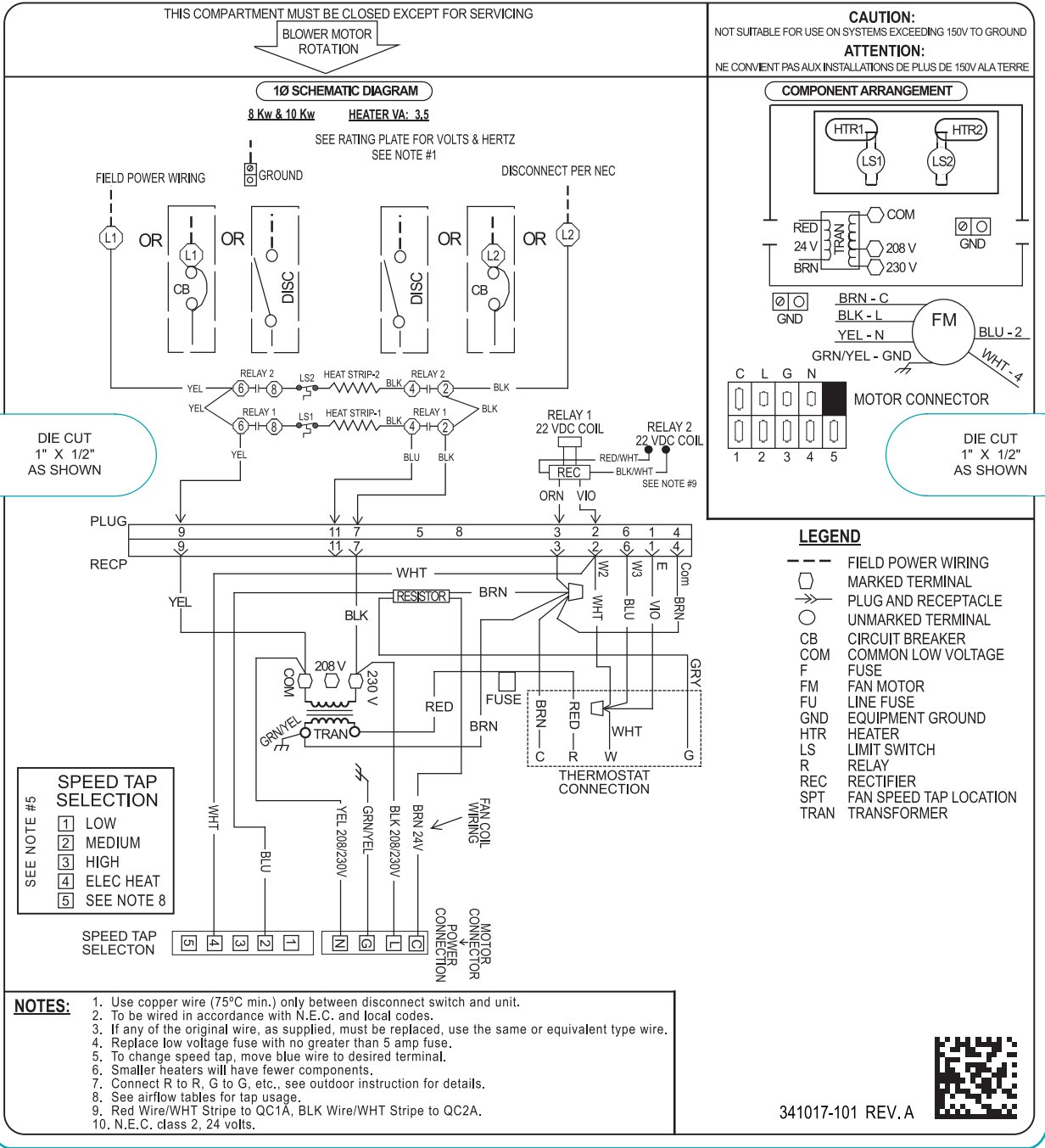

Fig. 10 - 341017-101

A150111

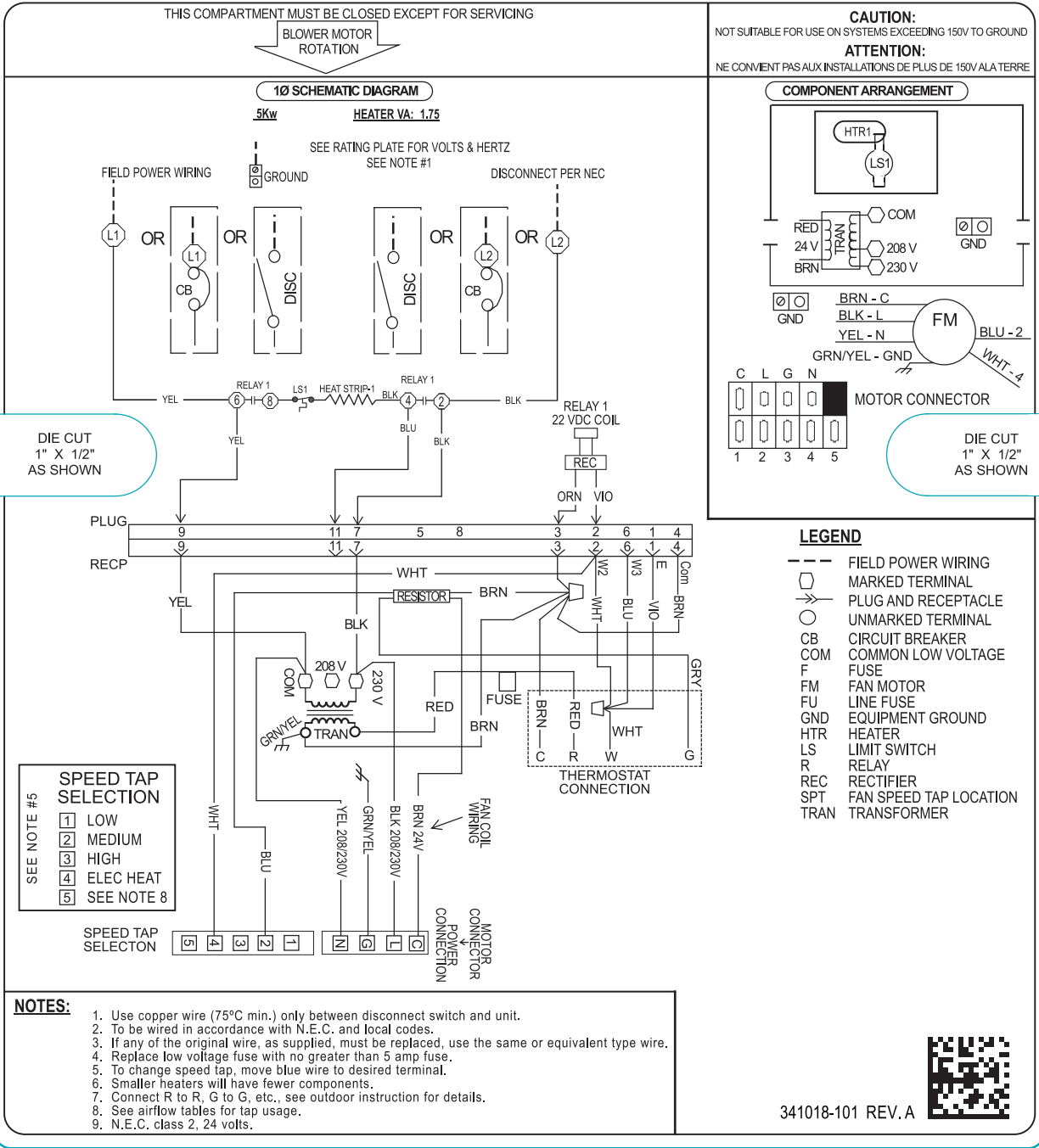

Fig. 11 - 341018-101

A150112

THIS COMPARTMENT MUST BE CLOSED EXCEPT FOR SERVICING

BLOWER MOTOR ROTATION

1Ø SCHEMATIC DIAGRAM

15 Kw HEATER VA: 5.25

FIELD POWER WIRING SEE RATING PLATE FOR VOLTS & HERTZ SEE NOTE #1 DISCONNECT PER NEC

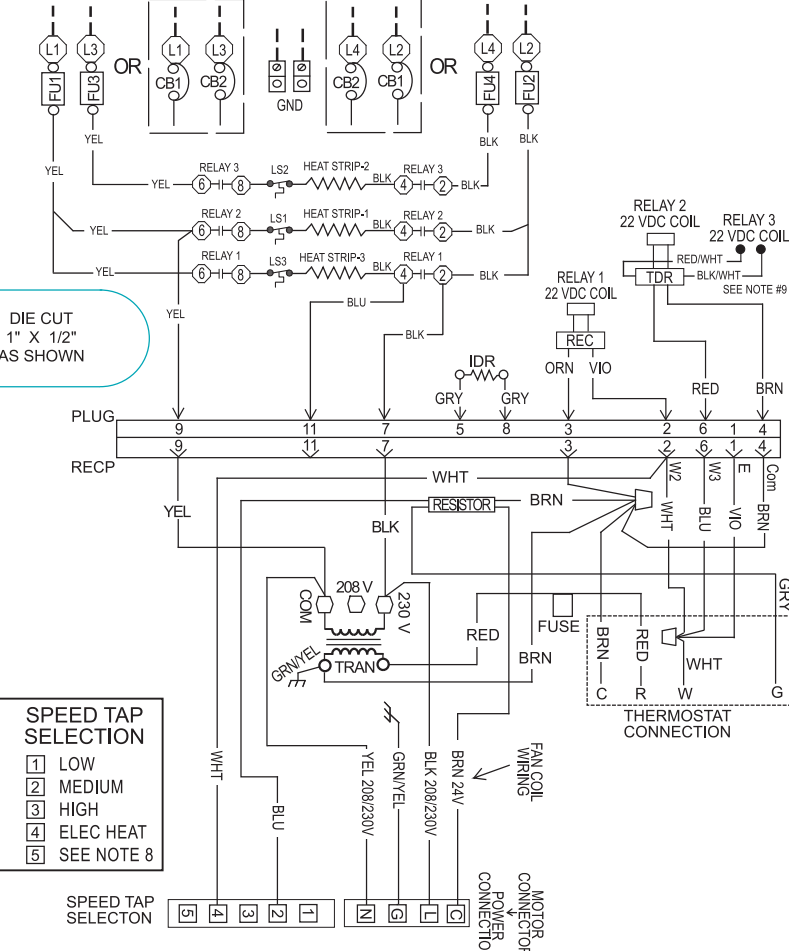

CAUTION:
NOT SUITABLE FOR USE ON SYSTEMS EXCEEDING 150V TO GROUND
ATTENTION:
NE CONVIENT PAS AUX INSTALLATIONS DE PLUS DE 150V ALA TERRE

COMPONENT ARRANGEMENT

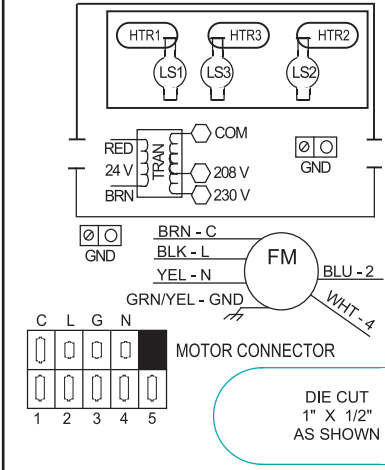

LEGEND

- FIELD POWER WIRING
- ◻ MARKED TERMINAL
- ⊙ PLUG AND RECEPTACLE
- UNMARKED TERMINAL
- CB CIRCUIT BREAKER
- COM COMMON LOW VOLTAGE
- F FUSE
- FM FAN MOTOR
- FU LINE FUSE
- GND EQUIPMENT GROUND
- HTR HEATER
- LS LIMIT SWITCH
- R RELAY
- REC RECTIFIER
- SPT FAN SPEED TAP LOCATION
- TRAN TRANSFORMER
- TDR TIME DELAY RECTIFIER

- NOTES:**
1. Use copper wire (75°C min.) only between disconnect switch and unit.
 2. To be wired in accordance with N.E.C. and local codes.
 3. If any of the original wire, as supplied, must be replaced, use the same or equivalent type wire.
 4. Replace low voltage fuse with no greater than 5 amp fuse.
 5. To change speed tap, move blue wire to desired terminal.
 6. Smaller heaters will have fewer components.
 7. Connect R to R, G to G, etc., see outdoor instruction for details.
 8. See airflow tables for tap usage.
 9. Red Wire/WHT Stripe to QC1A, BLK Wire/WHT Stripe to QC2A.
 10. N.E.C. class 2, 24 volts.

341019-101 REV. A



Fig. 12 - 341019-101

A150113

THIS COMPARTMENT MUST BE CLOSED EXCEPT FOR SERVICING

BLOWER MOTOR ROTATION

COOLING ONLY SCHEMATIC DIAGRAM

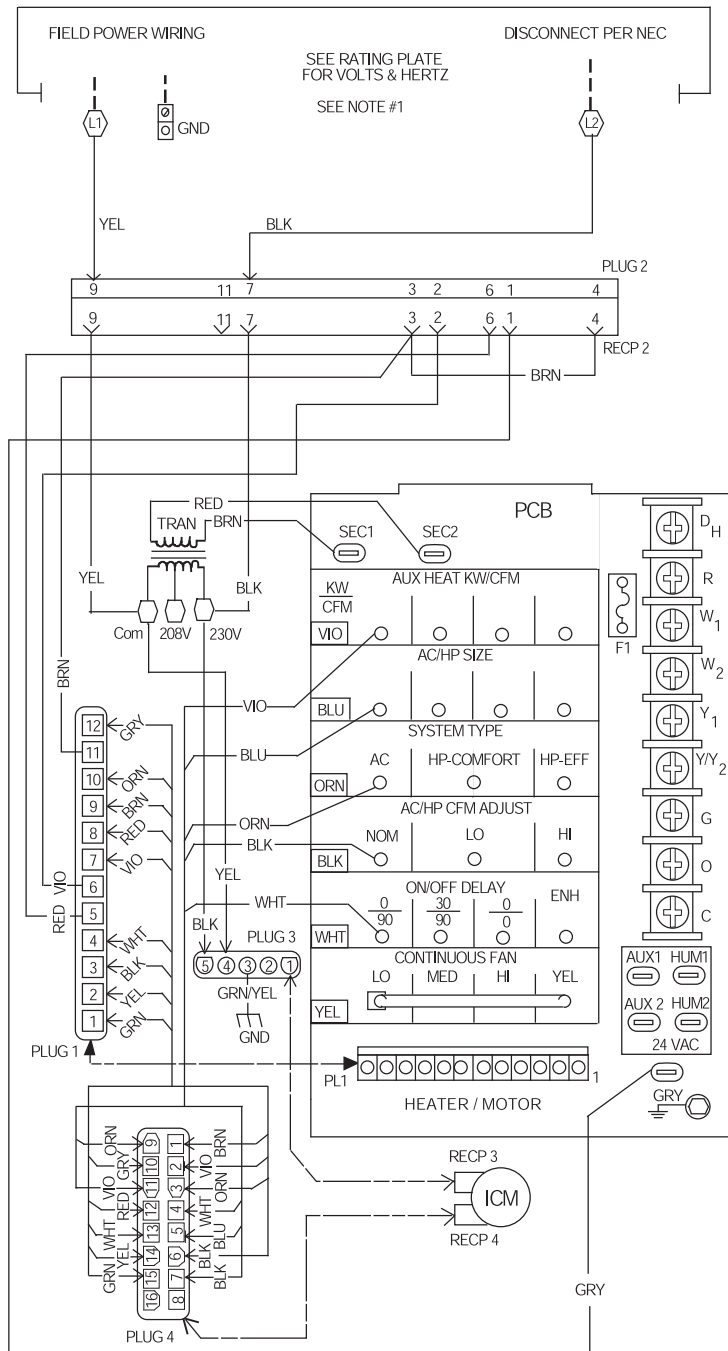

326014-101 REV. D

LEGEND

- FIELD POWER WIRING
- ⊕ MARKED TERMINAL
- ⎓ PLUG AND RECEPTACLE
- COM COMMON
- F1 LOW VOLTAGE FUSE
- GND EQUIPMENT GROUND
- ICM FAN MOTOR
- PCB PRINTED CIRCUIT BOARD
- RECP RECEPTACLE
- TRAN TRANSFORMER

COMPONENT ARRANGEMENT

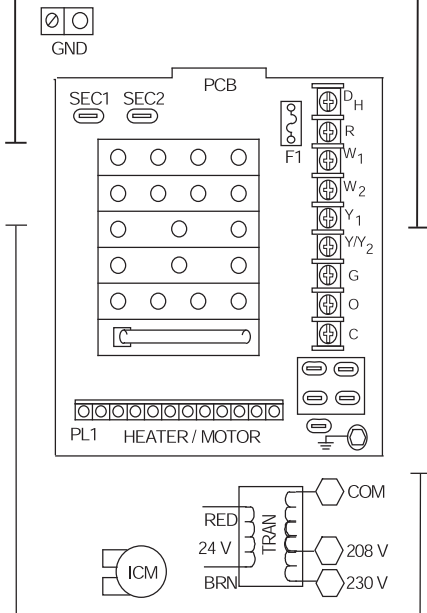

NOTES:

1. USE COPPER WIRE (75°C MIN) ONLY BETWEEN DISCONNECT SWITCH AND UNIT.
2. TO BE WIRED IN ACCORDANCE WITH N.E.C. AND LOCAL CODES.
3. TRANSFORMER PRIMARY LEADS, BLUE 208V, RED 230V.
4. IF ANY OF THE ORIGINAL WIRE, AS SUPPLIED, MUST BE REPLACED, USE THE SAME OR EQUIVALENT TYPE WIRE.
5. REPLACE LOW VOLTAGE FUSE WITH NO GREATER THAN 5 AMP FUSE.
7. USE 60 AMP CLASS K FUSES ONLY, FOR REPLACEMENT.
8. CONNECT R TO R, G TO G, ETC., SEE OUTDOOR INSTRUCTION FOR DETAILS.

Fig. 13 - 326014-101

A07029

THIS COMPARTMENT MUST BE CLOSED EXCEPT FOR SERVICING

BLOWER MOTOR
ROTATION

CAUTION:
NOT SUITABLE FOR USE
ON SYSTEMS EXCEEDING
150V TO GROUND

ATTENTION:
NE CONVIENT PAS A UX
INSTALLATIONS DE PLUS DE
150 V A LA TERRE

COOLING CONTROL ONLY

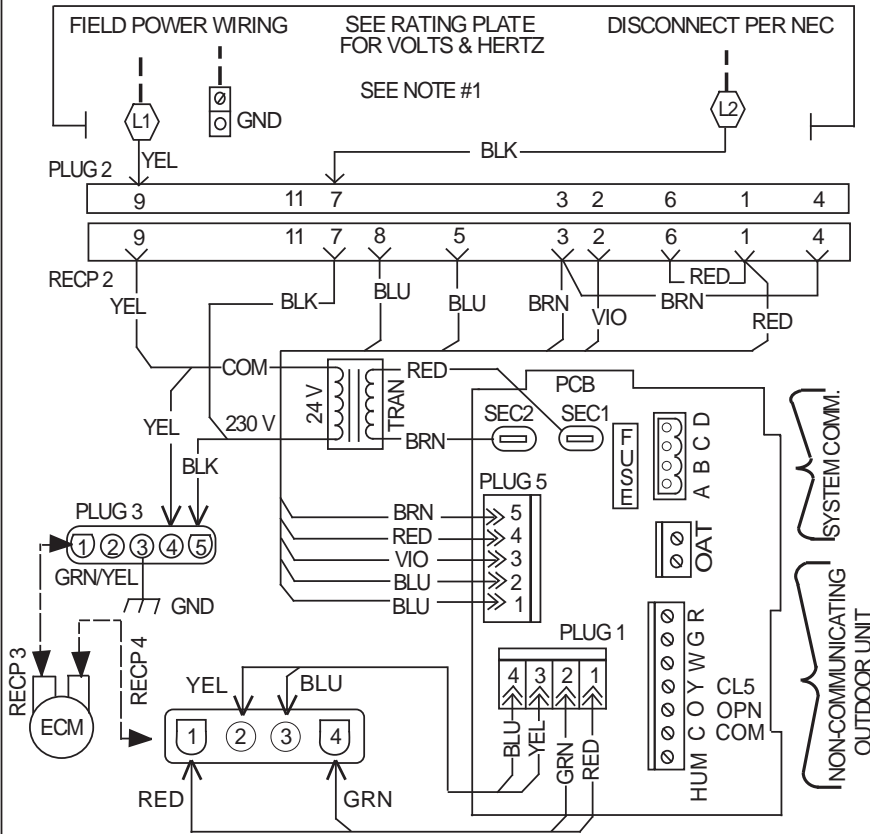

COMPONENT ARRANGEMENT

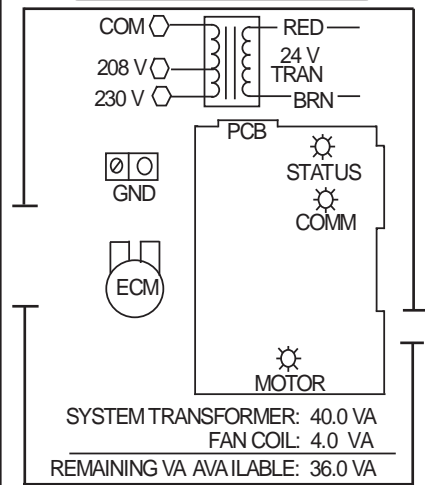

SYSTEM TRANSFORMER: 40.0 VA
FAN COIL: 4.0 VA
REMAINING VA AVAILABLE: 36.0 VA

NOTES:

1. Use Copper Wire (75°C Min) Only Between Disconnect Switch And Unit.
2. To Be Wired In Accordance With N.E.C. And Local Codes.
3. If Any Of The Original Wire, As Supplied, Must Be Replaced, Use The Same Or Equivalent Type Wire.
4. Replace Low Voltage Fuse With No Greater Than 5 Amp Fuse.
5. For Use With Communicating Thermostat Only, Connect A To A, B To B, Etc.
6. Communicating Outdoor Units Connect A To A, B To B, Etc.
7. Non - Communicating Outdoor Units Connect R To R, Y To Y, Etc.

TRUBLE SHOOTING INFORMATION:

MOTOR LED	MOTOR	FAULT / ACTION
OFF	NOT RUNNING	NONE - CHECK STATUS LED
OFF	RUNNING	MOTOR
ON (FLASHING)	NOT RUNNING	MOTOR / HARNESS
ON (FLASHING)	RUNNING	NONE

STATUS LED	FAULT / ACTION
ON	NONE - STANDBY MODE
OFF	NO LOW VOLTAGE OR CONTROL - CHECK POWER AND FUSE
16	NO SYSTEM COMMUNICATIONS - CHECK WIRING
OTHER	REFER TO SERVICE SCREENS ON USER INTERFACE OR THE FAN COIL TROUBLESHOOTING GUIDE

LEGEND

- FIELD POWER WIRING
- ◻ MARKED TERMINAL
- ⏏ PLUG AND RECEPTACLE
- COM COMMON
- GND EQUIPMENT GROUND
- ECM FAN MOTOR
- OAT OUTDOOR AIR THERMISTOR
- PCB PRINTED CIRCUIT BOARD
- RECP RECEPTACLE
- TRAN TRANSFORMER

333107-101 REV. B

Fig. 14 - 333107-101

A12363

THIS COMPARTMENT MUST BE CLOSED EXCEPT FOR SERVICING

BLOWER MOTOR
ROTATION

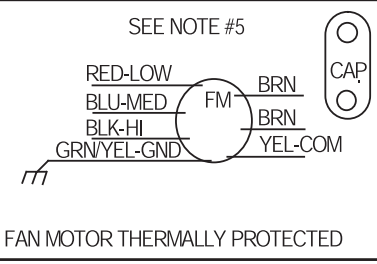
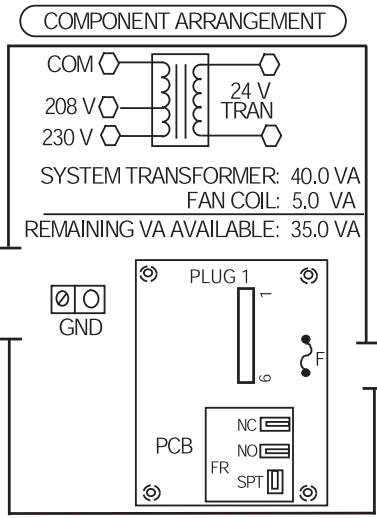
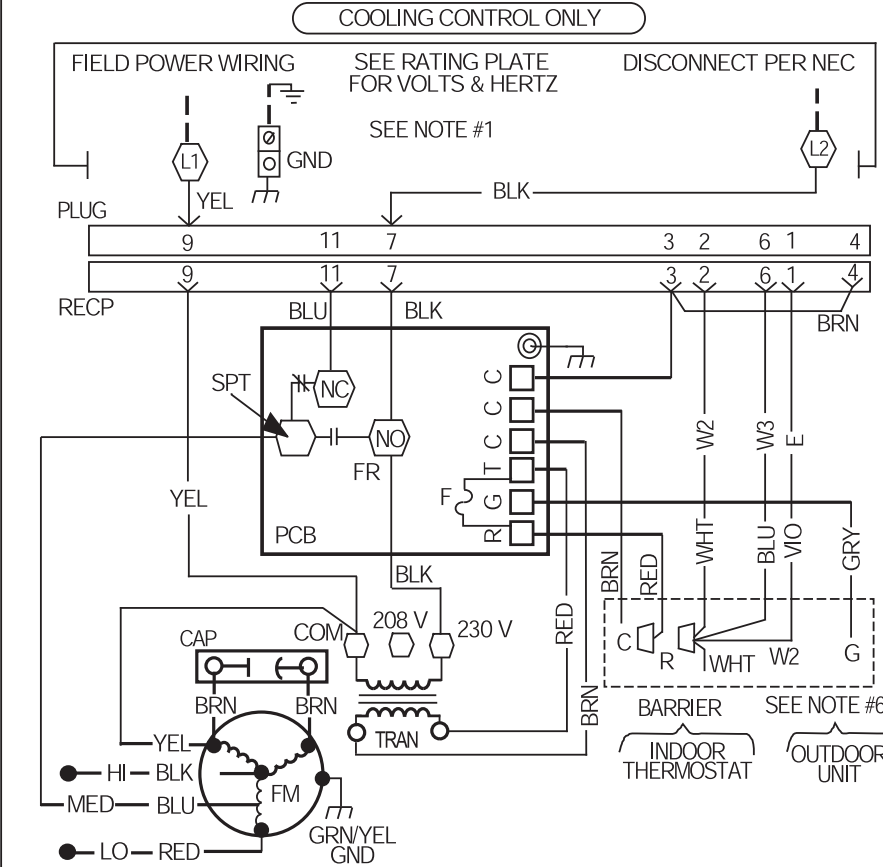

Minimum Motor Speed Tap Selection For Electric Heater

MODEL SIZE	HEATER SIZE KW						
	3,5,8	9	10	15	18	20	24, 30
18	MED*	----	HI	----	----	----	----
24	MED‡	----	MED‡	MED‡	----	---	----
30	----	----	LO	LO	----	MED*	----
36, 42, 48, 60	----	LO	LO	LO	LO	LO	LO
70	----	MED	MED	MED	MED	MED	MED

* - MED speed on 3 speed motors and HI speed on 2 speed motors.
 ‡ - MED speed on 3 speed motors and LO speed on 2 speed motors.

NOTES

1. Use Copper Wire (75°C Min) Only Between Disconnect Switch And Unit.
2. To Be Wired In Accordance With NEC And Local Codes.
3. If Any Of The Original Wire, As Supplied, Must Be Replaced, Use The Same Or Equivalent Type Wire.
4. Replace Low Voltage Fuse With No Greater Than 5 Amp Fuse.
5. (3) Speed Motor Shown Optional (2) Speed Motor Uses HI (BLK) And LOW (BLUE or RED).
6. Connect R To R, G To G, Etc. See Outdoor Instruction For Details.

LEGEND

- CAP CAPACITOR
- COM COMMON
- F LOW VOLTAGE FUSE
- FR PCB FAN RELAY
- FM FAN MOTOR
- GND EQUIPMENT GROUND
- PCB PRINTED CIRCUIT BOARD
- RECP RECEPTACLE
- SPT FAN SPEED TAP LOCATION
- TRAN TRANSFORMER
- UNMARKED TERMINAL
- FIELD POWER WIRING
- ◻ MARKED TERMINAL
- PLUG AND RECEPTACLE

328964-101 REV. A

Fig. 15 - 328964-101

A07027

THIS COMPARTMENT MUST BE CLOSED EXCEPT FOR SERVICING

BLOWER MOTOR ROTATION

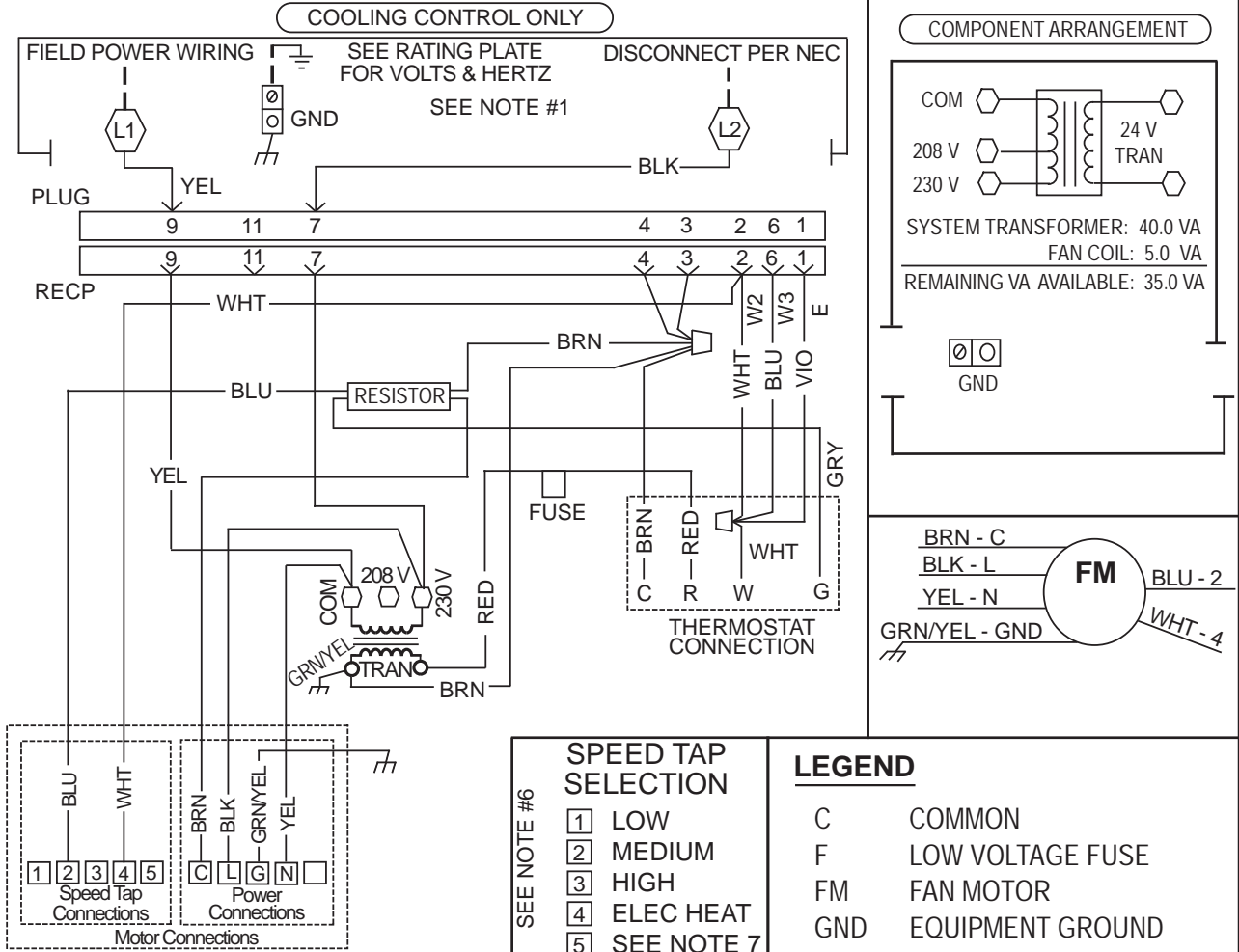

COMPONENT ARRANGEMENT

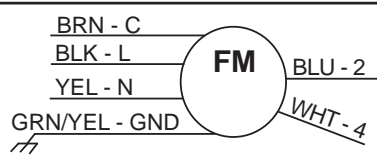
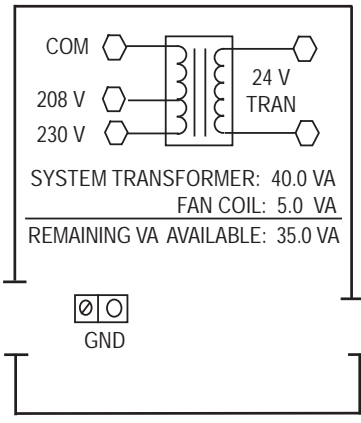

NOTES

1. Use Copper Wire (75°C Min) Only Between Disconnect Switch And Unit.
2. To Be Wired In Accordance With NEC And Local Codes.
3. If Any Of The Original Wire, As Supplied, Must Be Replaced. Use The Same Or Equivalent Type Wire.
4. Replace Low Voltage Fuse With No Greater Than 5 Amp Fuse.
5. Connect R To R, G To G, Etc. See Outdoor Instruction For Details.
6. To change speed tap, move blue wire to desired terminal.
7. See airflow tables for tap usage.

LEGEND

- C COMMON
- F LOW VOLTAGE FUSE
- FM FAN MOTOR
- GND EQUIPMENT GROUND
- RECP RECEPTACLE
- SPT FAN SPEED TAP LOCATION
- TRAN TRANSFORMER
- UNMARKED TERMINAL
- FIELD POWER WIRING
- ◻ MARKED TERMINAL
- ⇨ PLUG AND RECEPTACLE

336228-101 REV. A

Fig. 16 - 336228-101

A12364

THIS COMPARTMENT MUST BE CLOSED EXCEPT FOR SERVICING

BLOWER MOTOR ROTATION

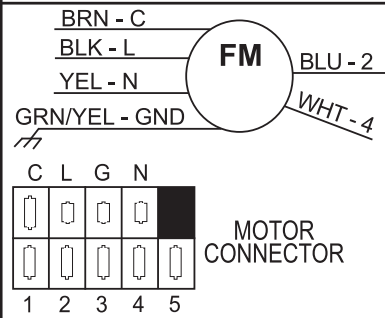
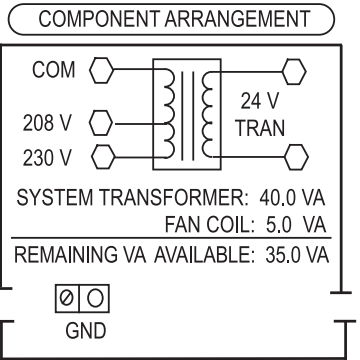
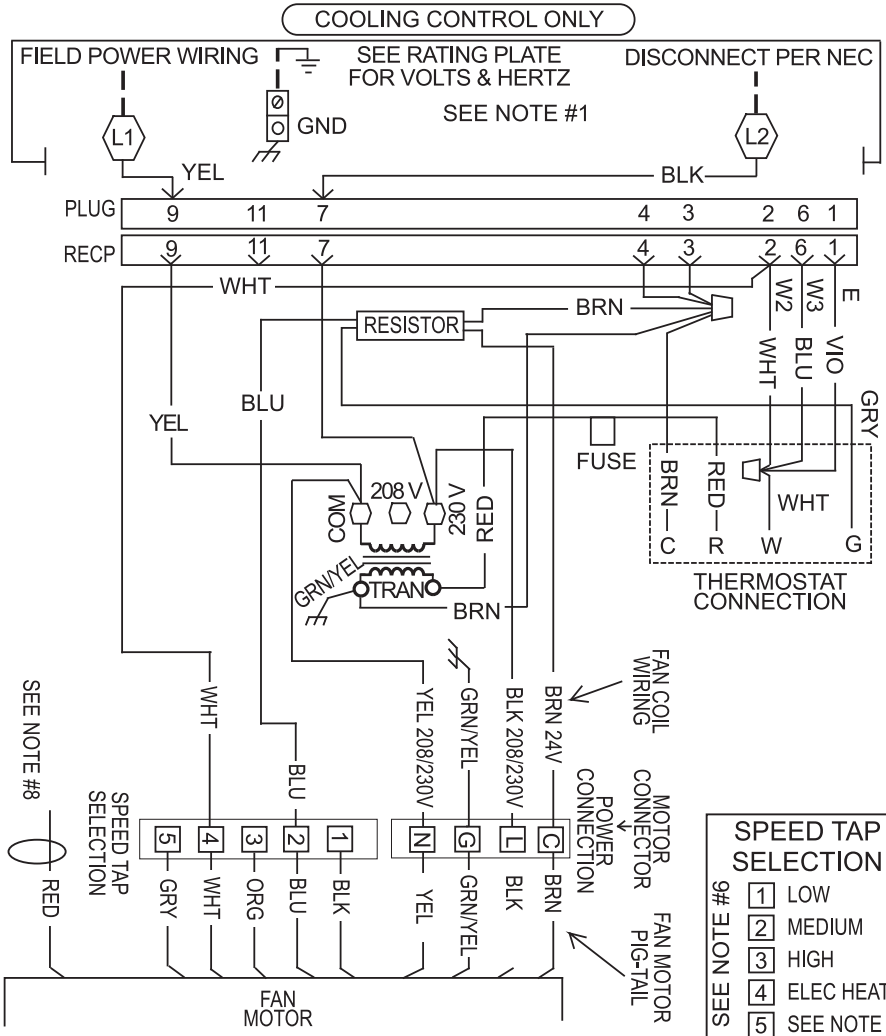

LEGEND

- C COMMON
- F LOW VOLTAGE FUSE
- FM FAN MOTOR
- GND EQUIPMENT GROUND
- RECP RECEPTACLE
- SPT FAN SPEED TAP LOCATION
- TRAN TRANSFORMER
- UNMARKED TERMINAL
- FIELD POWER WIRING
- ◻ MARKED TERMINAL
- PLUG AND RECEPTACLE

NOTES

1. Use Copper Wire (75°C Min) Only Between Disconnect Switch And Unit.
2. To Be Wired In Accordance With NEC And Local Codes.
3. If Any Of The Original Wire, As Supplied, Must Be Replaced. Use The Same Or Equivalent Type Wire.
4. Replace Low Voltage Fuse With No Greater Than 5 Amp Fuse.
5. Connect R To R, G To G, Etc. See Outdoor Instruction For Details.
6. To Change Speed Tap, Move Blue Wire To Desired Terminal.
7. See Airflow Tables For Tap Usage.
8. Factory wires may be present. DO NOT USE

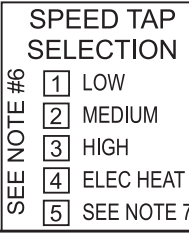

337519-101 REV. B



Fig. 17 - 337519-101

A12365

SCHEMATIC DIAGRAM

SEE RATING PLATE FOR VOLTS & HERTZ

FIELD POWER WIRING

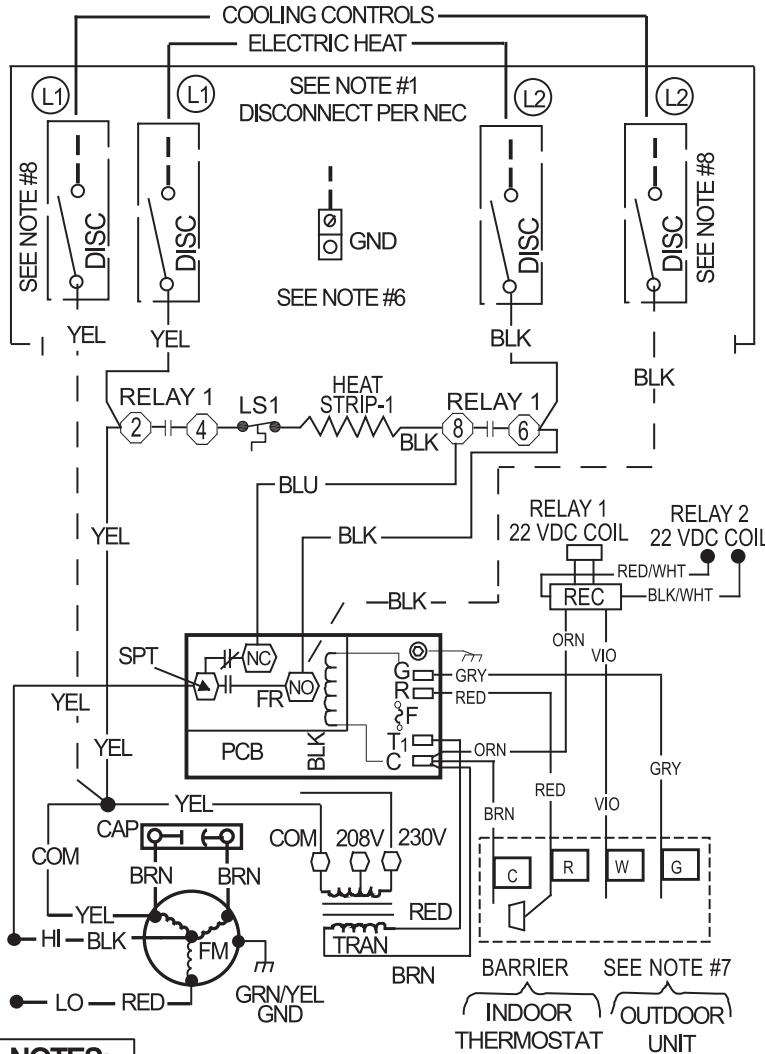

NOTES:

1. Use copper wire (75° C min) only between disconnect switch and unit.
2. To be wired in accordance with N.E.C. and local codes.
3. If any of the original wire, as supplied, must be replaced, use the same or equivalent type wire.
4. Replace low voltage fuse with no greater than 5 AMP fuse.
5. (2) Speed Motor uses HI (BLK) and LOW (RED).
6. Smaller heaters will have fewer components.
7. Connect R to R, G to G, etc., see outdoor instructions for details.
8. Cooling controls wiring not used with electric heaters.
9. Motor speed selection for 018 and 024 sizes with 11 kW heater and heat pump is High. All other heater combinations is Low.
10. N.E.C. Class 2, 24 Volts.

CAUTION:
NOT SUITABLE FOR USE ON SYSTEMS EXCEEDING 150V TO GROUND
ATTENTION:
NE CONVIENT PAS AUX INSTALLATIONS DE PLUS DE 150 V A LA TERRE

COMPONENT ARRANGEMENT

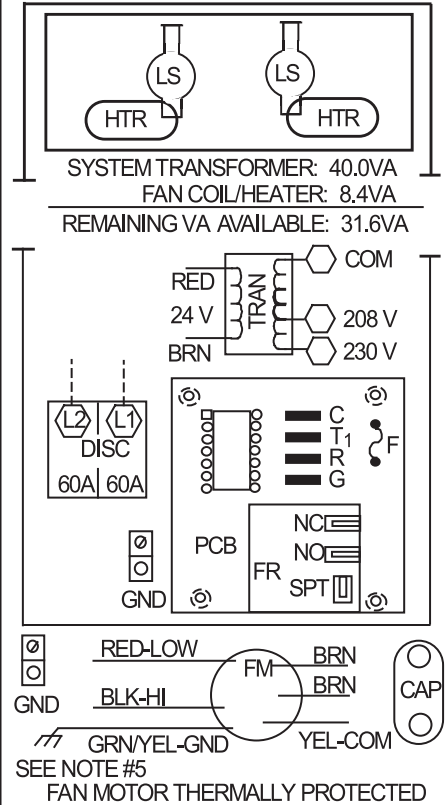

LEGEND

- | | |
|------|------------------------|
| CAP | CAPACITOR |
| COM | COMMON |
| DISC | DISCONNECT |
| F | FUSE |
| FM | FAN MOTOR |
| --- | FIELD POWER WIRING |
| FR | PCB FAN RELAY |
| GND | EQUIPMENT GROUND |
| HTR | HEATER |
| LS | LIMIT SWITCH |
| □ | MARKED TERMINAL |
| →→ | PLUG AND RECEPTACLE |
| PCB | PRINTED CIRCUIT BOARD |
| REC | RECTIFIER |
| SPT | FAN SPEED TAP LOCATION |
| TRAN | TRANSFORMER |
| ○ | UNMARKED TERMINAL |

This compartment must be closed except when servicing.

← ROTATION

341080-101 REV. A

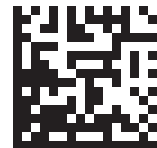
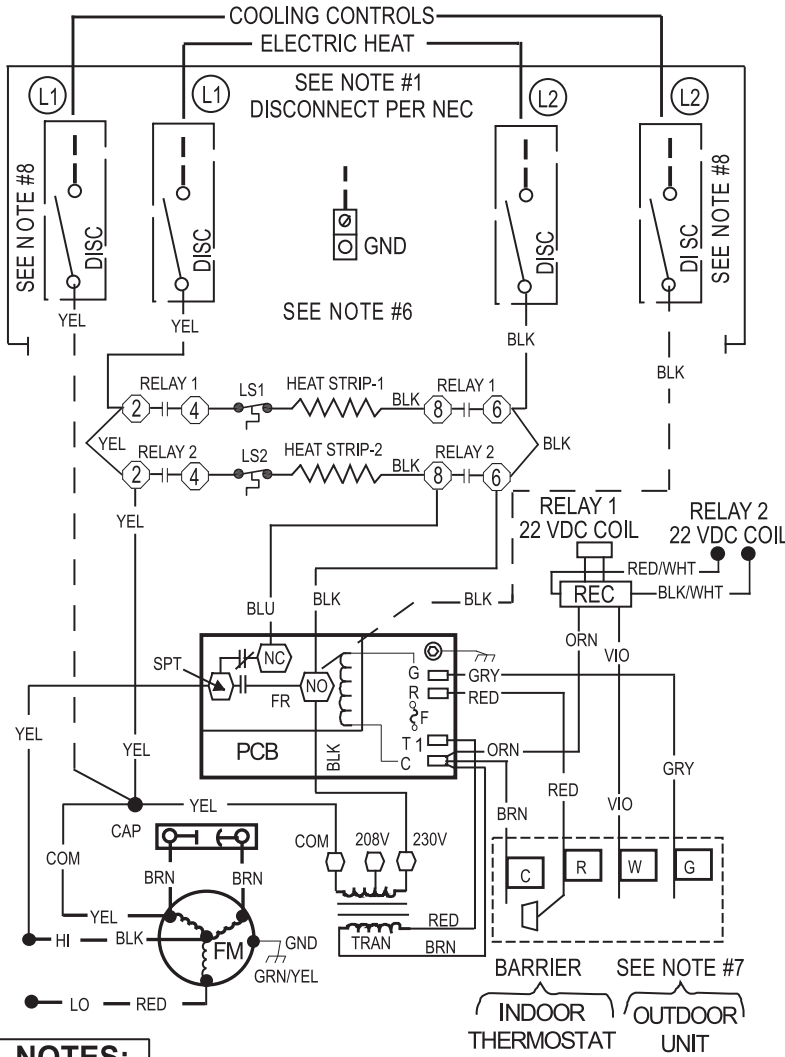

Fig. 18 - 341080-101

(SCHEMATIC DIAGRAM)

SEE RATING PLATE FOR VOLTS & HERTZ
FIELD POWER WIRING

CAUTION:
NOT SUITABLE FOR USE ON SYSTEMS EXCEEDING 150V TO GROUND
ATTENTION:
NE CONVIENT PAS AUX INSTALLATIONS DE PLUS DE 150V ALA TERRE



(COMPONENT ARRANGEMENT)

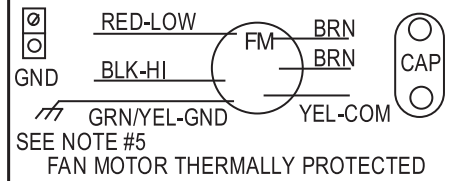
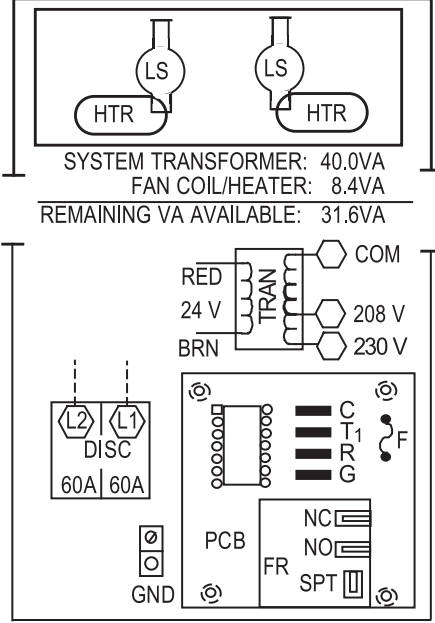

SEE NOTE #5
FAN MOTOR THERMALLY PROTECTED

LEGEND

- CAP CAPACITOR
- COM COMMON
- DISC DISCONNECT
- F FUSE
- FM FAN MOTOR
- FIELD POWER WIRING
- FR PCB FAN RELAY
- GND EQUIPMENT GROUND
- HTR HEATER
- LS LIMIT SWITCH
- MARKED TERMINAL
- PLUG AND RECEPTACLE
- PCB PRINTED CIRCUIT BOARD
- REC RECTIFIER
- SPT FAN SPEED TAP LOCATION
- TRAN TRANSFORMER
- UNMARKED TERMINAL

NOTES:

1. Use copper wire (75° C min) only between disconnect switch and unit.
2. To be wired in accordance with N.E.C. and local codes.
3. If any of the original wire, as supplied, must be replaced, use the same or equivalent type wire.
4. Replace low voltage fuse with no greater than 5 AMP fuse.
5. (2) Speed Motor uses HI (BLK) and LOW (RED).
6. Smaller heaters will have fewer components.
7. Connect R to R, G to G, etc., see outdoor instructions for details.
8. Cooling controls wiring not used with electric heaters.
9. Motor speed selection for 018 and 024 sizes with 11 kW heater and heat pump is High. All other heater combinations is Low.
10. N.E.C. Class 2, 24 Volts.

This compartment must be closed except when servicing.



341081-101 REV. A



Fig. 19 - 341081-101

SCHEMATIC DIAGRAM

SEE RATING PLATE FOR VOLTS & HERTZ
FIELD POWER WIRING

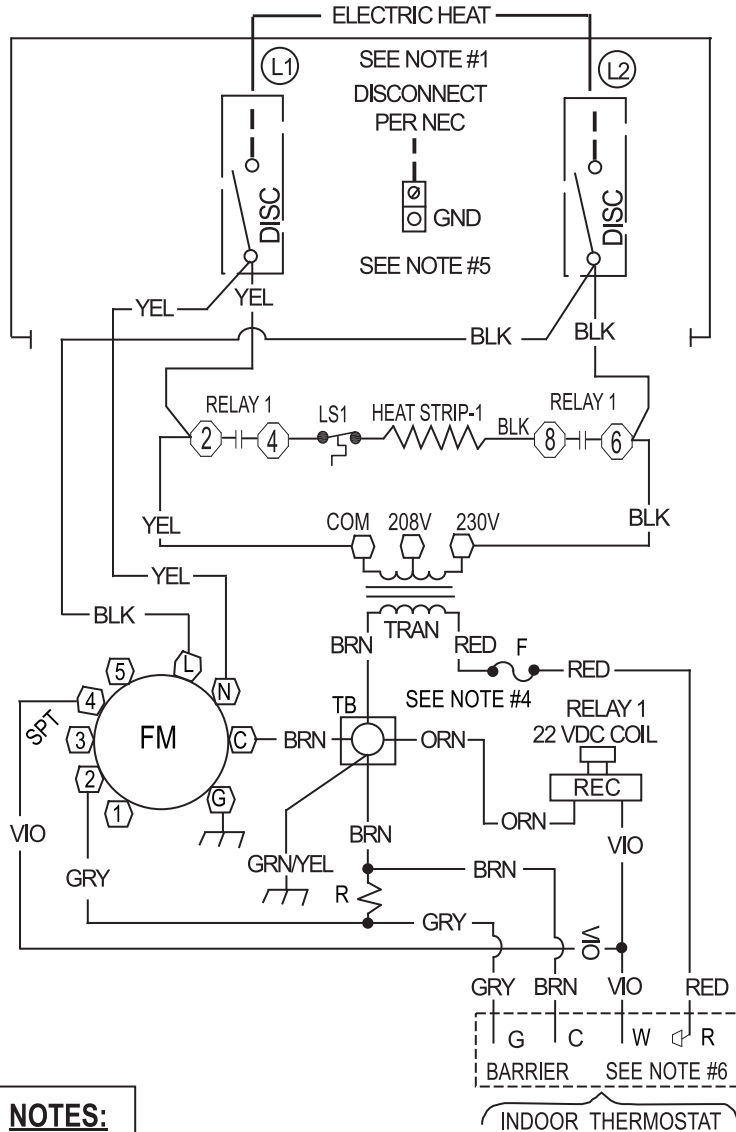

NOTES:

1. Use copper wire (75° C min) only between disconnect switch and unit.
2. To be wired in accordance with N.E.C. and local codes.
3. If any of the original wire, as supplied, must be replaced, use the same or equivalent type wire.
4. Replace low voltage fuse with no greater than 3 AMP fuse.
5. Smaller heaters will have fewer components.
6. Connect R to R, G to G, etc., see outdoor instructions for details.
7. Cooling speed selection can be tap 1, 2, 3, or 5.
8. Heating speed selection must be tap 4 only.
9. N.E.C. class 2, 24 volts.

COMPONENT ARRANGEMENT

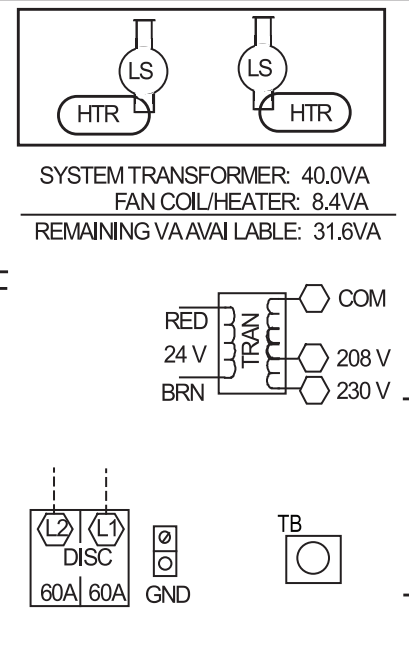

SYSTEM TRANSFORMER: 40.0VA
 FAN COIL/HEATER: 8.4VA
 REMAINING VA AVAILABLE: 31.6VA

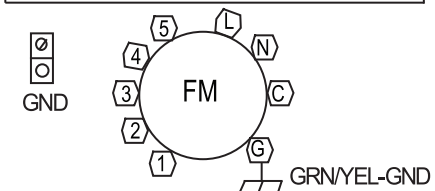

FAN MOTOR ELECTRONICALLY PROTECTED

LEGEND

- FIELD POWER WIRING
- ◻ MARKED TERMINAL
- PLUG AND RECEPTACLE
- UNMARKED TERMINAL
- ⋈ WIRE NUT
- COM COMMON
- DISC DISCONNECT
- F FUSE
- FM FAN MOTOR
- GND EQUIPMENT GROUND
- HIR HEATER
- LS LIMIT SWITCH
- R RESISTOR
- REC RECTIFIER
- SPT FAN SPEED TAP LOCATION
- TB TERMINAL BLOCK
- TRAN TRANSFORMER

This compartment must be closed except when servicing.



341082-101 REV. A

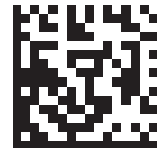
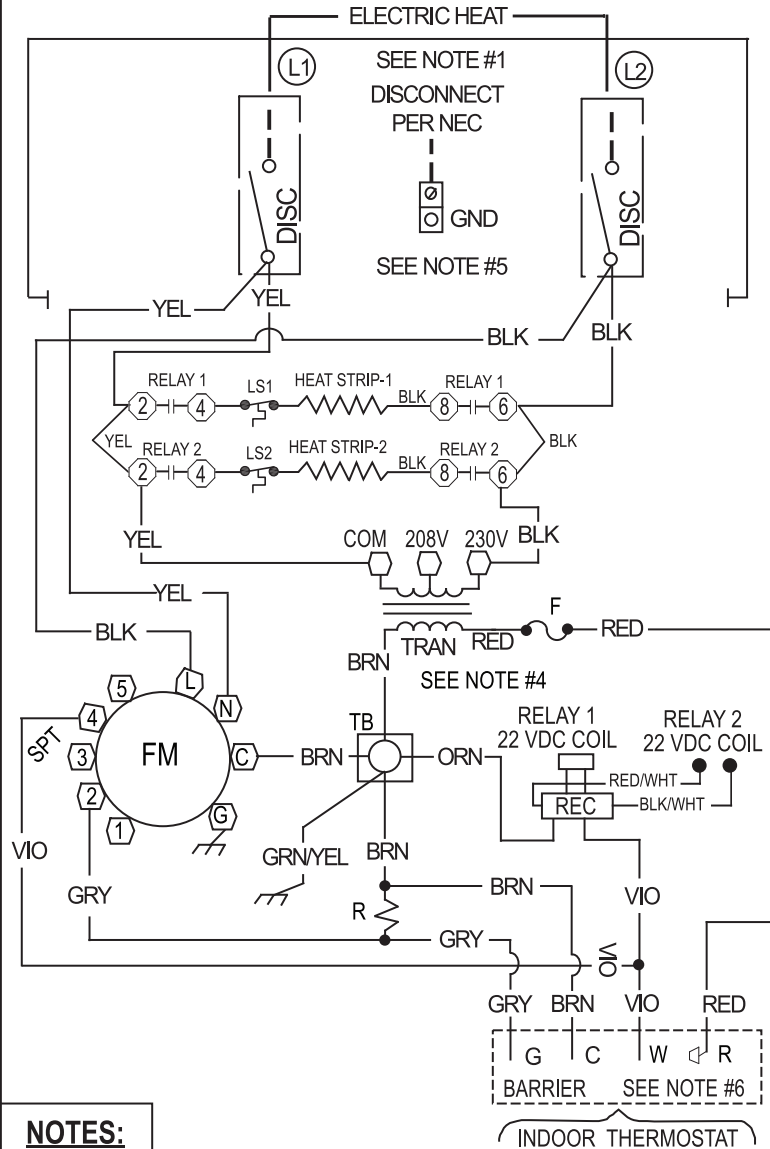

Fig. 20 - 341082-101

SCHEMATIC DIAGRAM
SEE RATING PLATE FOR VOLTS & HERTZ
FIELD POWER WIRING



NOTES:

1. Use copper wire (75° C min) only between disconnect switch and unit.
2. To be wired in accordance with N.E.C. and local codes.
3. If any of the original wire, as supplied, must be replaced, use the same or equivalent type wire.
4. Replace low voltage fuse with no greater than 3 AMP fuse.
5. Smaller heaters will have fewer components.
6. Connect R to R, G to G, etc., see outdoor instructions for details.
7. Cooling speed selection can be tap 1, 2, 3, or 5.
8. Heating speed selection must be tap 4 only.
9. N.E.C. class 2, 24 volts.

COMPONENT ARRANGEMENT

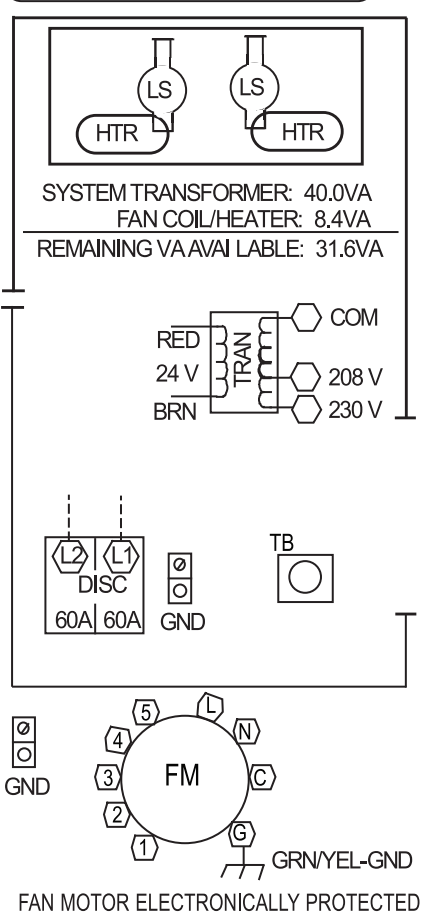

LEGEND

- FIELD POWER WIRING
- ◻ MARKED TERMINAL
- > PLUG AND RECEPTACLE
- UNMARKED TERMINAL
- ⋈ WIRE NUT
- COM COMMON
- DISC DISCONNECT
- F FUSE
- FM FAN MOTOR
- GND EQUIPMENT GROUND
- HTR HEATER
- LS LIMIT SWITCH
- R RESISTOR
- REC RECTIFIER
- SPT FAN SPEED TAP LOCATION
- TB TERMINAL BLOCK
- TRAN TRANSFORMER

This compartment must be closed except when servicing.



341083-101 REV. A



Fig. 21 - 341083-101

A150117

SCHEMATIC DIAGRAM

SEE RATING PLATE FOR VOLTS&HERTZ
FIELD POWER WIRING

CAUTION:
NOT SUITABLE FOR USE ON SYSTEMS EXCEEDING 150V TO GROUND
ATTENTION:
NE CONVIENT PAS AUX INSTALLATIONS DE PLUS DE 150V ALA TERRE

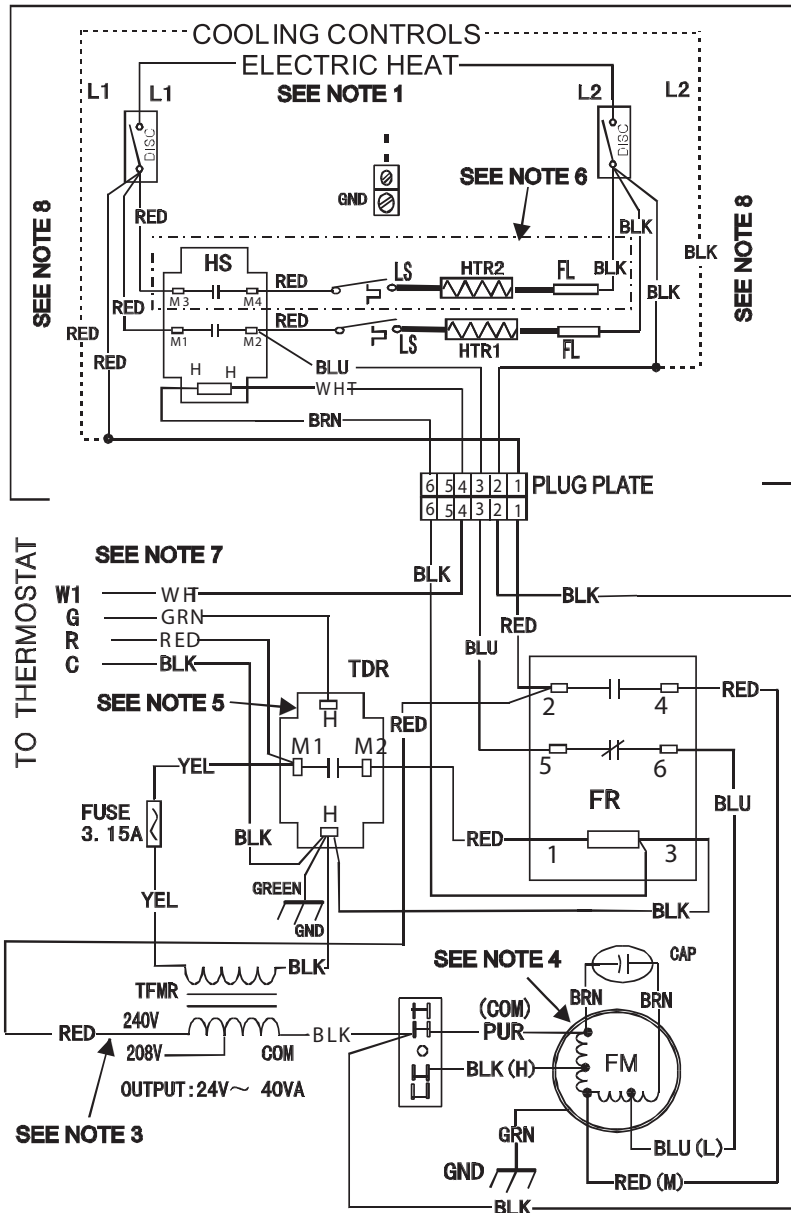

COMPONENT ARRANGEMENT

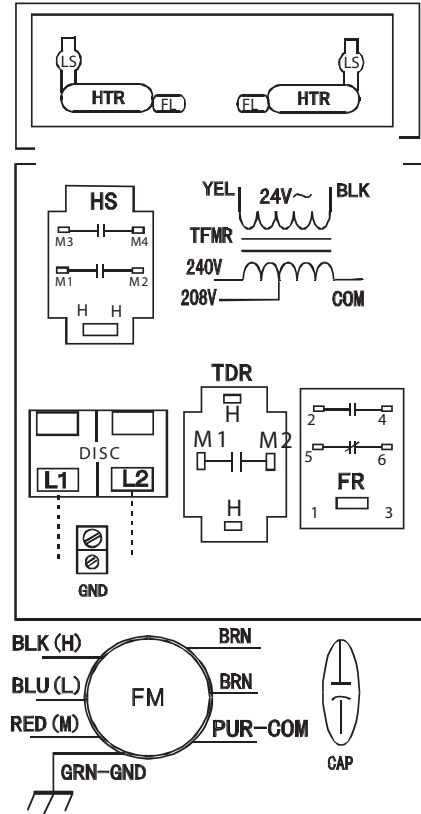

- DISC DISCONNECT
- FR FAN RELAY
- HS HEAT SEQUENCER
- LS LIMIT SWITCH
- TDR TIME DELAY RELAY
- TFMR TRANSFORMER
- FL FUSE LINK
- FM FAN MOTOR
- CAP FAN CAPACITOR
- GND GROUND
- - - FIELD POWER WIRING

NOTES:

- 1: Use copper wire(75°C min) only between disconnect switch and unit, To be wired in accordance with N.E.C. and local codes.
- 2: If any of the original wire as supplied must be replaced, use the same or equivalent type wire.
- 3: Remove the red lead from "240V" terminal and then connect the red lead to "208V" terminal on the transformer for 208 volts.
- 4: Factory default fan speed is medium; FM red wire connected to FR #4. For HI speed connect FM black wire to FR #4. For LOW speed connect FM blue wire to FR #4 and FM red wire to FR #6. Always connect the unused FM wire to the dummy terminal block.
- 5: TDR has a 1-30s on delay when "G" is energized and a 45-75s off delay when "G" is de-energized.
- 6: The 5kW heater kit has HTR1 only. Fan coils equipped with electric heat connect power supply to circuit breaker.
- 7: Connect R to R, G to G, etc. See outdoor or indoor instructions for details.
- 8: Cooling controls wiring not used with electric heaters.

202070290385

Fig. 22 - FFMANP(018,024,030,036 and EHK2 Electric Heaters with Sequencers
NOTE: Representative for FFMANP(018,024,030,036) prior to serial number date code 1715V

A13131

SCHEMATIC DIAGRAM
SEE RATING PLATE FOR VOLTS&HERTZ

CAUTION:
NOT SUITABLE FOR USE ON SYSTEMS EXCEEDING 150V TO GROUND
ATTENTION:
NE CONVIENT PAS AUX INSTALLATIONS DE PLUS DE 150V A LA TERRE

**ELECTRIC HEAT WIRING
CONNECTION (WHEN APPLIED)**

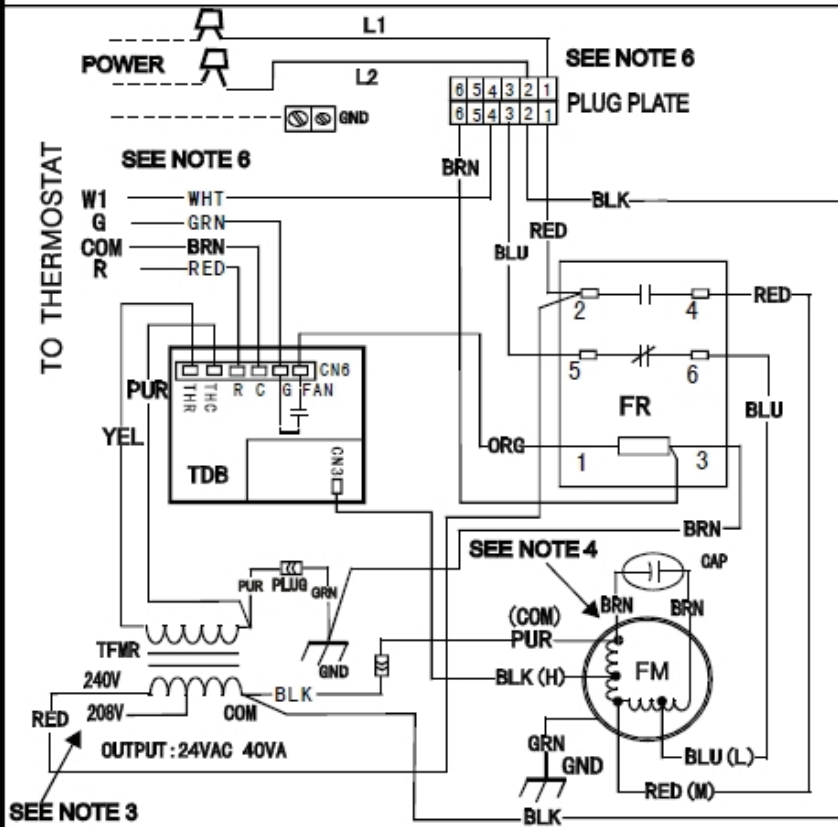

COMPONENT ARRANGEMENT

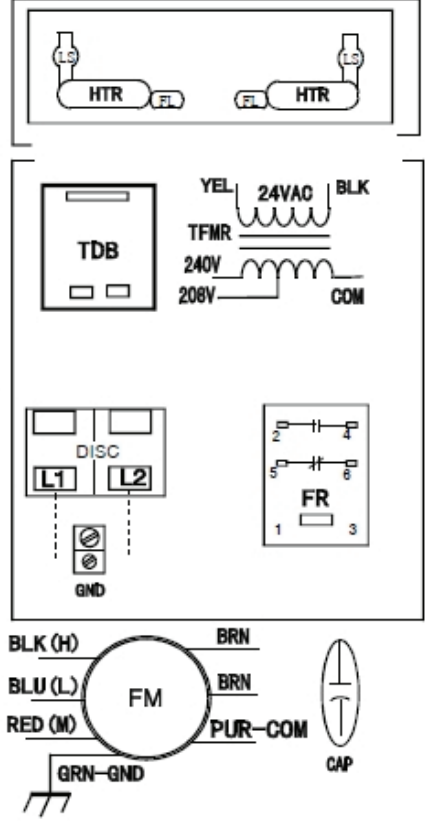

- FR FAN RELAY
- TDB TIME DELAY BOARD
- TFMR TRANSFORMER
- FM FAN MOTOR
- CAP FAN CAPACITOR
- GND GROUND
- - - FIELD POWER WIRING

- NOTES:**
- 1: Use copper wire(75°C min), to be wired in accordance with N.E.C. and local codes.
 - 2: If any of the original wire as supplied must be replaced,use the same or equivalent type wire.
 - 3: Remove the red lead from "240V" terminal and then connect the red lead to "208V" terminal on the transformer for 208 volts.
 - 4: Factory default fan speed is medium; FM red wire connected to FR #4. For HI speed connect FM black wire to FR #4. For LOW speed connect FM blue wire to FR #4 and FM red wire to FR #6. Always connect the unused FM wire to the dummy terminal CN3.
 - 5: TDB has a 90-100s off delay when "G" is de-energized.
 - 6:Connect R to R, G to G, etc. See outdoor or indoor instructions for details.
 - 7:Cooling controls wiring not used with electric heaters,connect the plug to electric heaters kit when applied.
 - 8: N.E.C., class2,24volts.

2020702A1717

Fig. 23 - FFMANP(018,024,030,036 with PCB Time Delay
NOTE: Representative for FFMANP(018,024,030,036) serial number date code 1715V and later.

SCHEMATIC DIAGRAM
SEE RATING PLATE FOR VOLTS & HERTZ
FIELD POWER WIRING

CAUTION:
 NOT SUITABLE FOR USE ON SYSTEMS EXCEEDING 150V TO GROUND
ATTENTION:
 NE CONVIENT PAS AUX INSTALLATIONS DE PLUS DE 150V ALA TERRE

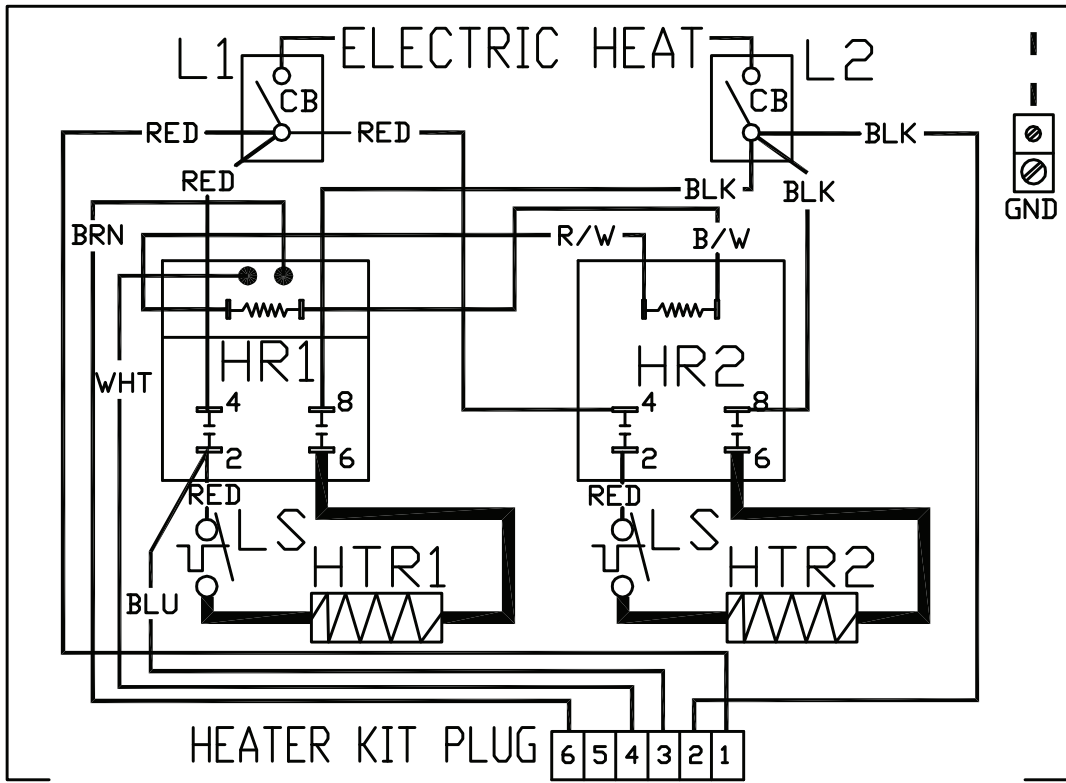

HR	HEATER RELAY			WHT	WHITE	B/W	BLACK/WHITE
CB	CIRCUIT BREAKER	LS	LIMIT SWITCH	BLU	BLUE	R/W	RED/WHITE
HTR	HEATER	GND	GROUND	BLK	BLACK	BRN	BROWN

TO UNIT

NOTES:

- 1: Use copper wire (75°C min) only between circuit breaker and unit. To be wired in accordance with N.E.C. and local codes.
- 2: If any of the original wire as supplied must be replaced, use the same or equivalent type wire.
- 3: The 5KW heater kit has HTR1 only. Fan coils equipped with electric heat connect power supply to circuit breaker.

06-7094-02

Fig. 24 - EHK2 With Heater Relays

SCHEMATIC DIAGRAM
SEE RATING PLATE FOR VOLTS&HERTZ
FIELD POWER WIRING

CAUTION:
NOT SUITABLE FOR USE ON SYSTEMS EXCEEDING 150V TO GROUND
ATTENTION:
NE CONVIENT PAS AUX INSTALLATIONS DE PLUS DE 150V ALA TERRE

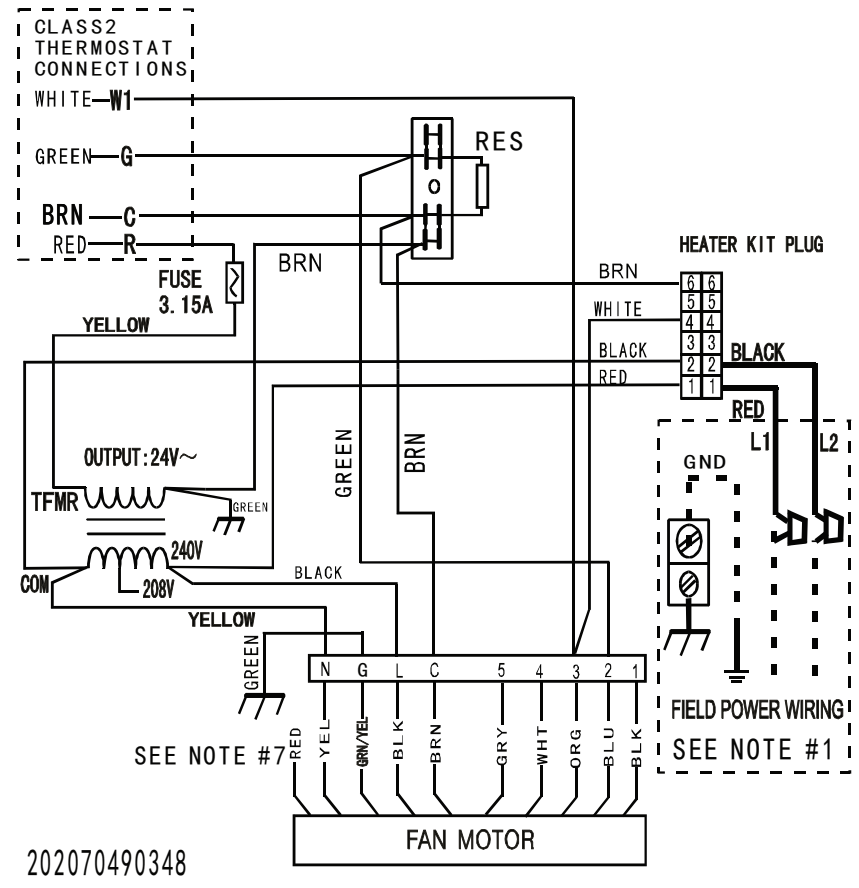

COMPONENT ARRANGEMENT

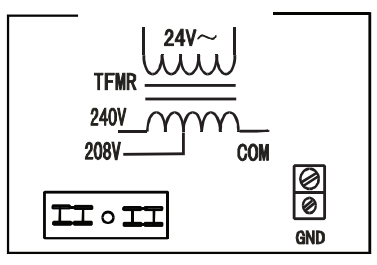

SPEED TAP SELECTION

- 1 LOW
- 2 MEDIUM LOW
- 3 MEDIUM
- 4 MEDIUM HIGH
- 5 HIGH

SEE NOTE #5, #6 & #8.

202070490348

NOTES:

- 1: Use Copper Wire (75°C Min) Only Between Disconnect Swith And Unit .
- 2: To Be Wired In Accordance With NEC And Local Codes.
- 3: If Any Of The Original Wire ,As Supplied, Must Be Replaced. Use The Same Or Equivalent Type Wire.
- 4: Connect R To R, G To G, Etc. See Outdoor Instruction For Details.
- 5: To Change Speed Tap, Move Green Wire Desired Terminal.
- 6: See Airflow Tables For Tap Usage.
- 7: Factory Wires May Be Present, DO NOT USE.
- 8: Taps 2 & 4 Have a 90s Delay Off, Taps 1, 3 & 5 are 30s.

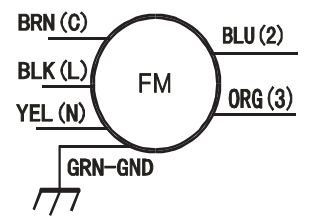

TFMR TRANSFORMER
FM FAN MOTOR
GND GROUND
RES RESISTOR
- - - FIELD POWER WIRING

Fig. 25 - FFMANP(019, 031)

A14323

SCHEMATIC DIAGRAM
SEE RATING PLATE FOR VOLTS&HERTZ
FIELD POWER WIRING

CAUTION:
NOT SUITABLE FOR USE ON SYSTEMS EXCEEDING 150V TO GROUND
ATTENTION:
NE CONVIENT PAS AUX INSTALLATIONS DE PLUS DE 150V A LA TERRE

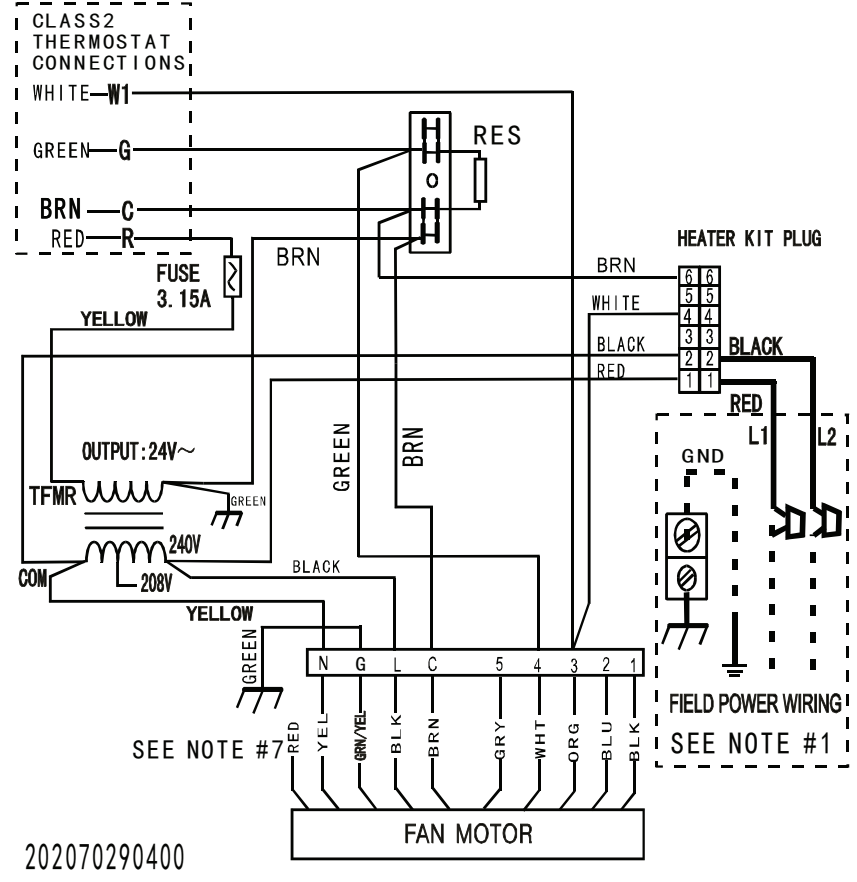

COMPONENT ARRANGEMENT

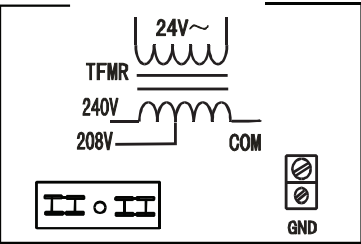

SPEED TAP SELECTION

- 1 LOW
- 2 MEDIUM LOW
- 3 MEDIUM
- 4 MEDIUM HIGH
- 5 HIGH

SEE NOTE #5, #6 & #8.

202070290400

NOTES:

- 1: Use Copper Wire (75°C Min) Only Between Disconnect Switch And Unit .
- 2: To Be Wired In Accordance With NEC And Local Codes.
- 3: If Any Of The Original Wire ,As Supplied, Must Be Replaced. Use The Same Or Equivalent Type Wire.
- 4: Connect R To R, G To G, Etc. See Outdoor Instruction For Details.
- 5: To Change Speed Tap, Move Green Wire Desired Terminal.
- 6: See Airflow Tables For Tap Usage.
- 7: Factory Wires May Be Present, DO NOT USE.
- 8: Taps 2 & 4 Have a 90s Delay Off, Taps 1, 3 & 5 are 30s.

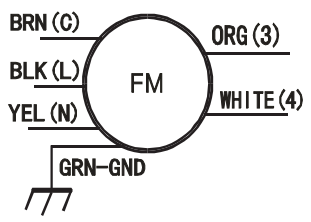

TFMR TRANSFORMER
FM FAN MOTOR
GND GROUND
RES RESISTOR
- - - FIELD POWER WIRING

Fig. 26 - FFMANP(025, 037)

A14324

SCHEMATIC DIAGRAM
SEE RATING PLATE FOR VOLTS&HERTZ
FIELD POWER WIRING

CAUTION:
 NOT SUITABLE FOR USE ON SYSTEMS EXCEEDING 150V TO GROUND
ATTENTION:
 NE CONVIENT PAS AUX INSTALLATIONS DE PLUS DE 150V ALA TERRE

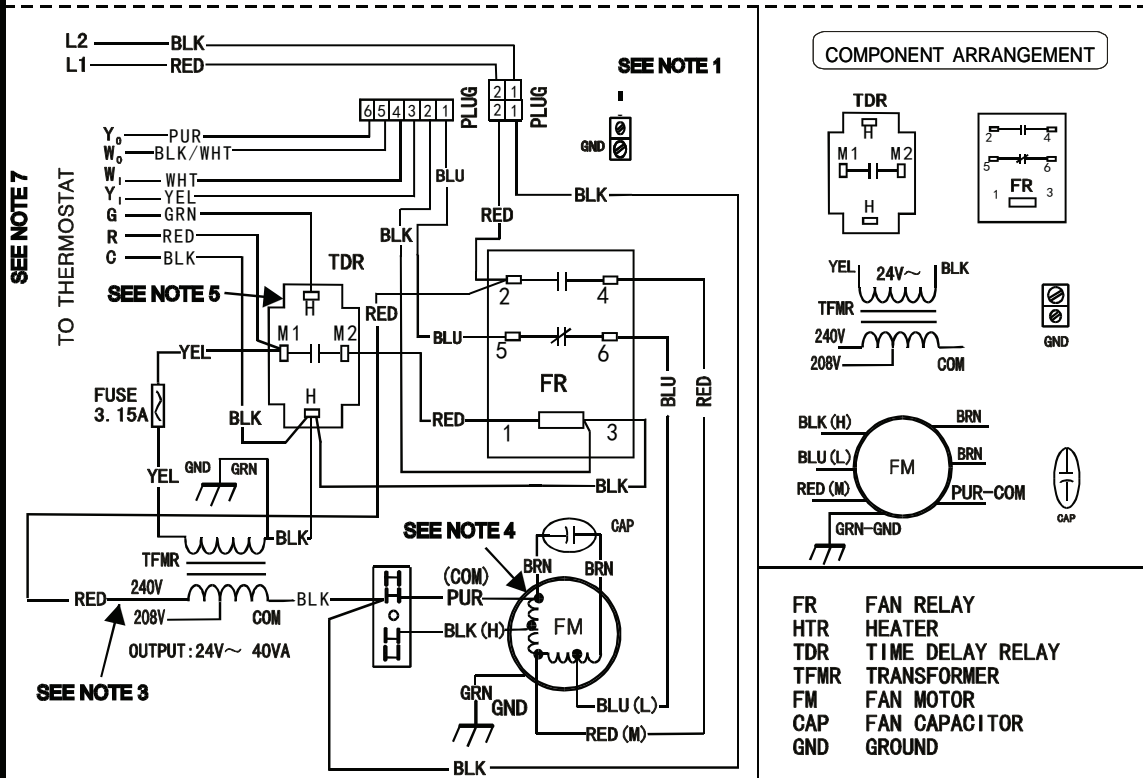

- NOTES:**
- 1: Use copper wire(75°C min) only between disconnect switch and unit, To be wired in accordance with N.E.C. and local codes. Fan coils equipped with electric heater connect power supply to terminal block. Cooling controls wiring not used with electric heaters.
 - 2: If any of the original wire as supplied must be replaced, use the same or equivalent type wire.
 - 3: Remove the red lead from "240V" terminal and then connect the red lead to "208V" terminal on the transformer for 208 volts.
 - 4: Factory default fan speed is Medium, FM red wire connected to FR #4; For HI speed connect FM black wire to FR #4; For LOW speed connect FM blue wire to FR #4, and FM red wire connected to FR #6. Always connect the unused FM wire to the dummy terminal block.
 - 5: TDR has a 1-20s on delay when "G" is energized and a 50-70s off delay when "G" is de-energized.
 - 6: Connect R to R, G to G, etc. See outdoor or indoor instructions for details.

202070290388

Fig. 27 - FPM(A,B)N(U,C)

A14325

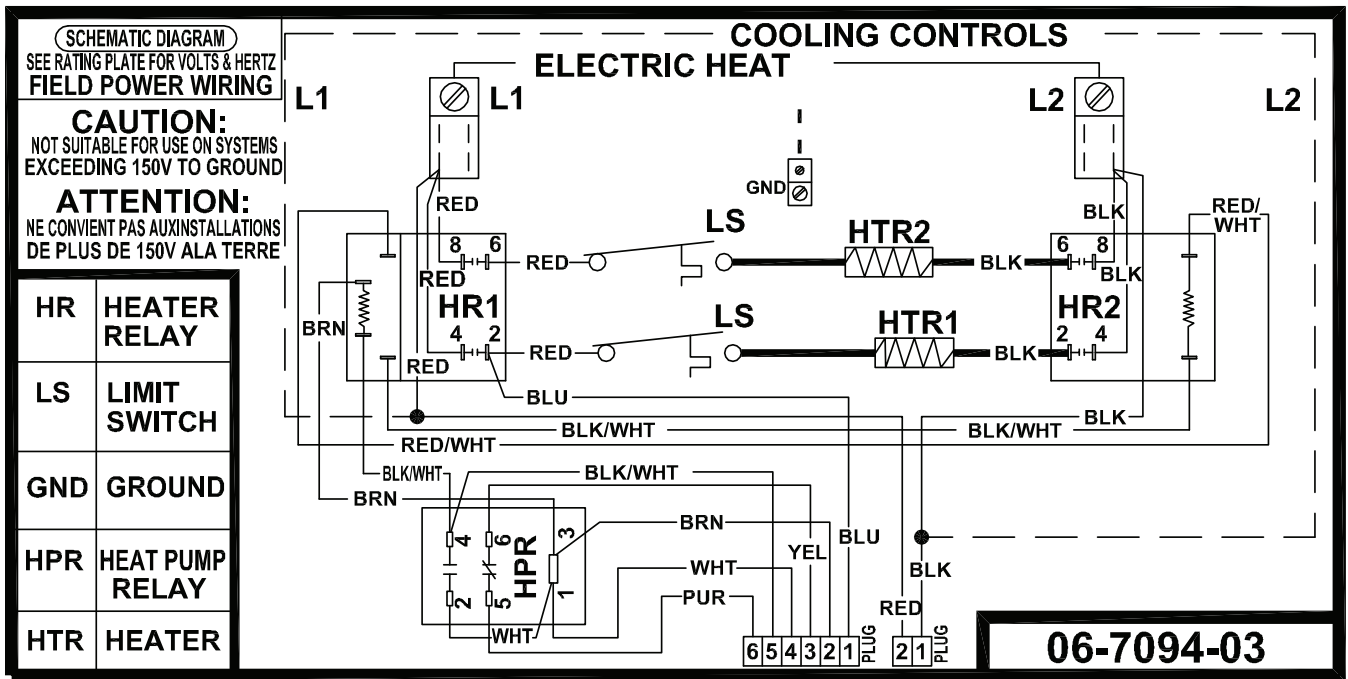

Fig. 28 - EHK3 With Heater Relays

A150101