



TOSHIBA

Carrier

AIR CONDITIONER (SPLIT TYPE)

Installation manual



Outdoor Unit

For OUTDOOR USE only

Model name:

RAV-SP180AT2-UL

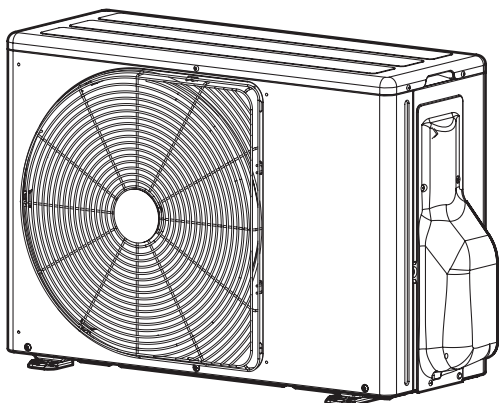

Installation manual
Air conditioner (Split type)

1 English

Manuel d'installation
Climatiseur (Type split)

19 Français

Please read this Installation Manual carefully before installing the Air Conditioner.

- This Manual describes the installation method of the outdoor unit.
- For installation of the indoor unit, refer to the Installation Manual attached to the indoor unit.

ADOPTION OF NEW REFRIGERANT

This Air Conditioner uses R410A an environmentally friendly refrigerant.



Contents

1	DIMENSION	2
2	ACCESSORY PARTS.....	3
3	SYSTEM REQUIREMENTS	4
4	PRECAUTIONS FOR SAFETY.....	5
5	INSTALLATION OF NEW REFRIGERANT AIR CONDITIONER.....	7
6	REFRIGERANT PIPING	12
7	ELECTRICAL CONNECTIONS	14
8	EVACUATE AND DEHYDRATE THE SYSTEM.....	15
9	FINISHING.....	17
10	TEST RUN.....	17
11	PERIODIC MAINTENANCE	17
12	UNIT PUMP DOWN.....	18
13	POWER SAVE	18

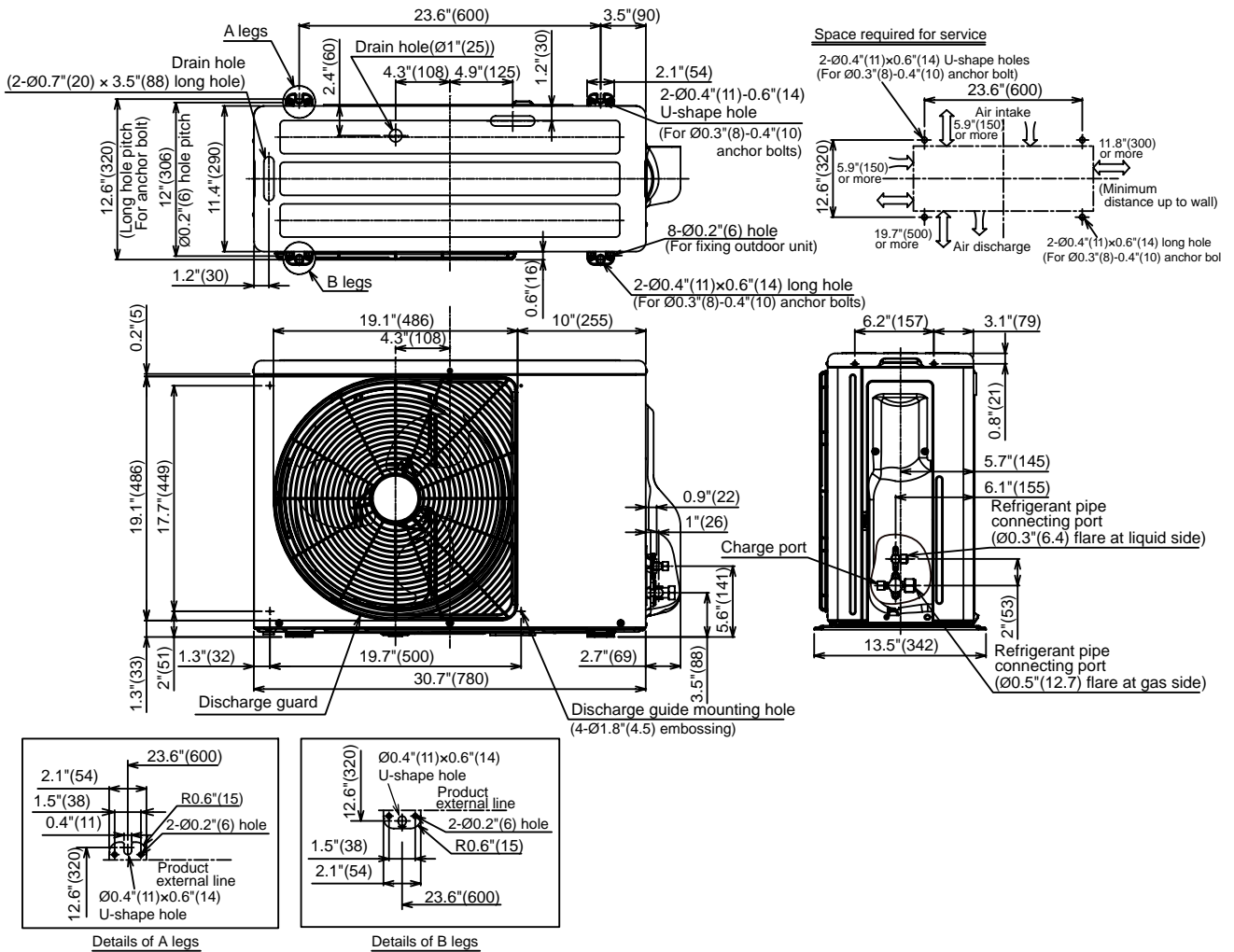
1 DIMENSION

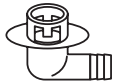

2 ACCESSORY PARTS

Part name	Q'ty	Shape	Usage
Installation manual	1	This manual	(Hand this directly to the customer.)
Drain nipple	1		
Waterproof rubber cap	2		

NOTE

Use drain nipple and waterproof rubber cap as necessary.

3 SYSTEM REQUIREMENTS

■ Piping (Field supplied)

- Minimum refrigerant line length between the outdoor unit and indoor unit is 16.5" (5 m)
- Maximum pipe lengths

Allowable pipe length (ft (m))	Height difference (Indoor-outdoor H) (ft (m))		Number of bent portions
	Indoor unit: Upper	Outdoor unit: Lower	
Total length L			10 or less
164'1" (50)	98'5" (30)	98'5" (30)	

Figure of Single

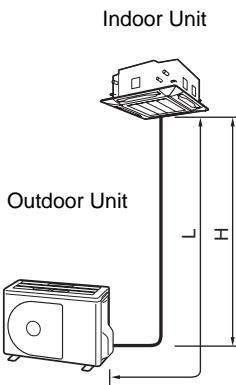

Refrigerant sizes

Liquid side		Gas side	
Outer diameter	Thickness	Outer diameter	Thickness
Ø1/4" (6.4 mm)	0.03" (0.8 mm)	Ø1/2" (12.7 mm)	0.03" (0.8 mm)

Flare nuts and flaring

- The flare nuts and flaring are different from those for the conventional refrigerant. Use the flare nuts supplied with the air conditioner or those for R410A.
- Before performing flaring, carefully read "REFRIGERANT PIPING"

Insulation

Both lines need to be insulated. Use a minimum 0.4" (10 mm) wall thickness.

Refrigerant charge

Length of refrigerant pipe connected to indoor/outdoor unit	Additional refrigerant
16'5" - 65'7" (5 - 20 m)	None
*65'7" - 164'1" (20 - 50 m)	Add 0.22 oz/ft (20 g/m) of refrigerant for piping that exceeds 65'7" (20 m) up to 164'1" (50 m).

- * Caution during addition of refrigerant
Max. amount of additional refrigerant is 1.8 lbs (800 g).
Charge the refrigerant accurately. Overcharging may cause serious trouble with the compressor.
- * Minimum refrigerant pipe is 16'5" (5 m).
This may cause a malfunction of the compressor or other devices.

Metering Device is an electronic EXV (PMV) in outdoor unit.

■ Connecting power and control cables (Field supplied)

- The main power is supplied to the outdoor unit. The field supplied connecting cables from the outdoor unit to the indoor unit consist for 4 wires and provides the power for the indoor unit as well as the communication signal between the outdoor and indoor unit.
- Consult local building codes, NEC (National Electrical Code) or CEC (Canadian Electrical Code) for special requirements.
- The following are the electrical requirements.

Model RAV-	SP180
Power supply	208/230 V~, 60 Hz
MCA	17 A
MOCP (MAX Fuse/CB)	30 A
Breaker	20 A
Power wire	Maximum 65'7" (20 m) 2 x AWG12 Ground : AWG14
System interconnection wires	4 x AWG12

MCA = Minimum Circuit Amps
MOCP = Maximum Over Protection Device Amps.

4 PRECAUTIONS FOR SAFETY

Installing, starting up, and servicing air-conditioning equipment can be hazardous due to system pressures, electrical components, and equipment location (roofs, elevated structures, etc.).

Only trained, qualified installers and service mechanics should install, start-up, and service this equipment.

Untrained personnel can perform basic maintenance functions such as cleaning coils. All other operations should be performed by trained service personnel.

When working on the equipment, observe precautions in the literature and on tags, stickers, and labels attached to the equipment.

Follow all safety codes. Wear safety glasses and work gloves. Keep quenching cloth and fire extinguisher nearby when brazing. Use care in handling, rigging, and setting bulky equipment.

Read these instructions thoroughly and follow all warnings or cautions included in literature and attached to the unit. Consult local building codes and National Electrical Code (NEC) for special requirements. Recognize safety information. This is the safety-alert symbol . When you see this symbol on the unit and in instructions or manuals, be alert to the potential for personal injury. Understand these signal words: DANGER, WARNING, and CAUTION. These words are used with the safety-alert symbol.

DANGER identifies the most serious hazards which will result in severe personal injury or death. WARNING signifies hazards which could result in personal injury or death. CAUTION is used to identify unsafe practices which may result in minor personal injury or product and property damage. NOTE is used to highlight suggestions which will result in enhanced installation, reliability, or operation.

WARNING

- **Ask an authorized dealer or qualified installation professional to install/maintain the air conditioner. Perform installation work properly according to the Installation Manual.**
Inappropriate installation may result in water leakage, electric shock or fire.
- **Be sure to ground the equipment**
Improper grounding may cause an electric shock.
Do not connect ground wires to gas pipes, water pipes, lightning rods or ground wires for telephone wires.
- **Turn off the circuit breaker before attempting any electrical work and maintenance.**
Make sure the circuit breaker is off. Failure to do so may cause electric shock.
Use an exclusive power circuit for the air conditioner. Use the rated voltage.
- **When moving the air conditioner for installation to another place, be very careful not to allow the specified refrigerant (R410A) to become mixed with any other gaseous body into the refrigeration cycle.**
If air or any other gas mixes with the refrigerant, the gas pressure in the refrigeration cycle will become abnormally high and it may result in the pipe bursting or personal injuries.
- **Do not modify this unit by removing any of the safety guards or by by-passing any of the safety interlock switches.**
- **Do not touch the intake or aluminium fins of the outdoor unit.**
Doing so may result in injury.
- **Tighten the flare nut with a torque wrench in the specified manner.**
Excessive tightening of the flare nut may cause a crack in the flare nut after a long period, which may result in refrigerant leakage.
- **Install the air conditioner securely in a location where the base can sustain the weight of the unit adequately.**
- **If refrigerant gas has leaked during the installation work, ventilate the room immediately.**
If the leaked refrigerant gas comes in contact with fire, noxious gas may be generated.
- **After the installation work, confirm that refrigerant gas does not leak.**
If refrigerant gas leaks into the room and flows near a fire source, such as a cooking range, noxious gas may be generated.
- **Electrical work must be performed by a qualified electrician in accordance with the NEC and local code. Make sure the air conditioner uses an exclusive power supply.**
An insufficient power supply capacity or inappropriate installation may cause fire.
- **Use only the specified wiring during the unit installation. Ensure that all terminals are securely fixed, so preventing any external forces having a negative effect on the terminals.**

 **WARNING**

- **When the air conditioner cannot cool or heat a room well, contact the dealer from whom you purchased the air conditioner as refrigerant leakage is considered as the cause.**
In the case of repair that requires refill of refrigerant, ask service personnel about details of the repair.
The refrigerant used in the air conditioner is harmless.
Generally, the refrigerant does not leak. However, if the refrigerant leaks in a room and a heater or stove burner in the room catches fire, it may generate toxic gas.
When you ask service personnel for repairing refrigerant leakage, confirm that the leakage portion has been completely repaired.
- **Do not install the air conditioner in a location that may be subjected to a risk of exposure to a combustible gas.**
If a combustible gas leaks and becomes concentrated around the unit, a fire may occur.
- **Install the refrigerant pipe securely during the installation work before operating the air conditioner.**
If the compressor is operated with the valve open and without the refrigerant pipe, the compressor sucks air and the refrigeration cycle is over pressurized, which may cause a burst or injury.
- **When carrying out the pump-down work, shut down the compressor before disconnecting the refrigerant pipe.**
Disconnecting the refrigerant pipe with the service valve left open and with the compressor still operating will cause air, etc. to be sucked in, raising the pressure inside the refrigeration cycle to an abnormally high level, and possibly resulting in rupturing, injury, etc.

 **CAUTION**

- **Do not climb onto or place objects on top of the outdoor unit.**
You may fall or the objects may fall off of the outdoor unit and result in injury.
- **Wear heavy gloves during the installation work to avoid injury.**

EQUIPMENT DAMAGE HAZARD

Failure to follow this caution may result in equipment damage or improper operation.

Do not bury more than 36 in. (914 mm) of refrigerant pipe in the ground. If any section of pipe is buried, there must be a 6 in. (152 mm) vertical rise to the valve connections on the outdoor units. If more than the recommended length is buried, refrigerant may migrate to the cooler buried section during extended periods of system shutdown. This causes refrigerant slugging and could possibly damage the compressor at start-up.

5 INSTALLATION OF NEW REFRIGERANT AIR CONDITIONER

⚠ CAUTION

New Refrigerant Air Conditioner Installation

- THIS AIR CONDITIONER ADOPTS THE NEW HFC REFRIGERANT (R410A) WHICH DOES NOT DESTROY OZONE LAYER.

R410A refrigerant is apt to be affected by impurities such as water, oxidizing membrane, and oils because the working pressure of R410A refrigerant is approx. 1.6 times as that of refrigerant R22. Accompanied with the adoption of the new refrigerant, the refrigerant oil has also been changed. Therefore, during installation work, be sure that water, dust, former refrigerant, or refrigerant oil does not enter the new type refrigerant R410A air conditioner cycle.

To prevent mixing of refrigerant or refrigerant oil, the sizes of connecting sections of charging port on main unit and installation tools are different from those of the conventional refrigerant units. Accordingly, special tools are required for the new refrigerant (R410A) units. For connecting pipes, use new and clean piping materials with high pressure fittings made for R410A only, so that water and/or dust does not enter.

■ Required Tools/Equipment and Precautions for Use

Prepare the tools and equipment listed in the following table before starting the installation work.

△ : R410A exclusive

◎ : Generic

Tools/equipment	Use	
Manifold gauge*	Vacuuming/charging refrigerant and operation check	△
Charging hose		△
Gas leak detector		△
Vacuum pump with backflow prevention function	Vacuum drying	◎
Flare tool	Flare machining of pipes	◎ Usable if dimensions are adjusted.
Bender	Bending pipes	◎
Refrigerant recovery equipment	Refrigerant recovery	△
Torque wrench	Tightening flare nuts	△ Ø1/4" (6.4 mm) and Ø1/2" (12.7 mm)
Pipe cutter	Cutting pipes	◎
Brazing torch and nitrogen cylinder	Braze pipes	◎
Refrigerant charging scales	Charging refrigerant	◎
4 mm hexagon wrench	Opening liquid valve	

■ Installation Location

⚠ WARNING

Install the outdoor unit in a location that can support the weight of the outdoor unit.

Insufficient durability may cause the outdoor unit to fall, which may result in injury.

⚠ CAUTION

Do not install the outdoor unit in a location that is subject to combustible gas leaks.

Accumulation of combustible gas around the outdoor unit may cause a fire.

Install the outdoor unit in a location that meets the following conditions.

- A well-ventilated location free from obstacles near the air inlets and air outlet
- A location that does not increase the operating noise or vibration of the outdoor unit
- A location that does not produce any drainage problems from discharged water
- Location with easy access to power.

Do not install the outdoor unit in the following location.

- A location with a saline atmosphere (coastal area) or one that is full of sulfide gas (hot-spring area) (Special maintenance is required.)
- A location subject to oil, vapor, oily smoke, or corrosive gases
- A location in which organic solvent is used
- A location where high-frequency equipment (including inverter equipment, private power generator, medical equipment, and communication equipment) is used (Installation in such a location may cause malfunction of the air conditioner, abnormal control or problems due to noise from such equipment.)
- A location in which the discharged air of the outdoor unit blows against the window of a neighboring house
- A location where the operating noise of the outdoor unit is transmitted
- When the outdoor unit is installed in an elevated position, be sure to secure its feet.
- A location in which drain water poses any problems.

When an outdoor unit is installed in a location that is always exposed to strong winds like a coast or on the high stories of a building, one of the following is recommended.

- Install the unit so that its discharge faces the wall of the structure.
Keep a distance 19.7" (500 mm) or more between the unit and wall.

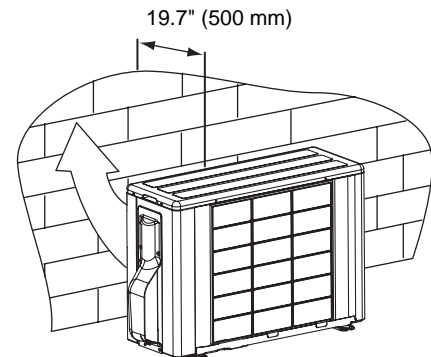

- Install the unit so that the discharge is at a right angle relative to the wind direction.

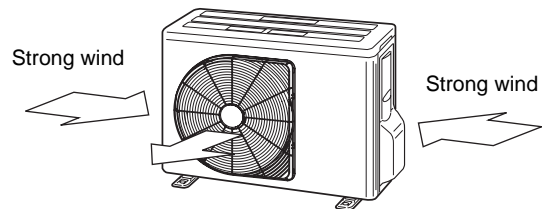

- Use wind baffle. Produce those parts in the field.
- When outside temperature conditions are 23 °F (-5 °C) or lower and unit is running in cooling mode.

<Example>

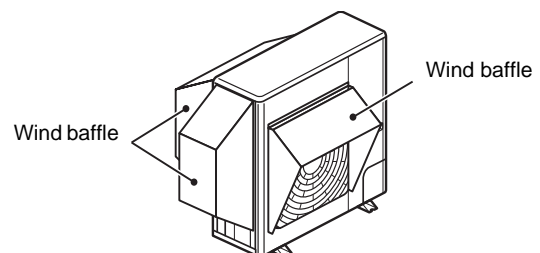

Required Clearances

Unit : in (mm)

Barrier at rear side

Upper side is free

1. Single unit installation

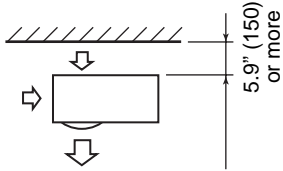

2. Barrier on right, left and rear.

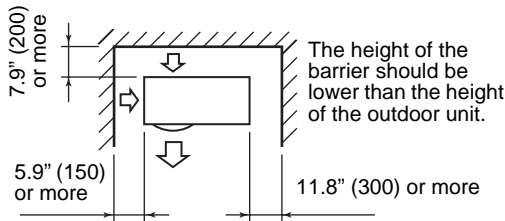

3. Multiple units installation

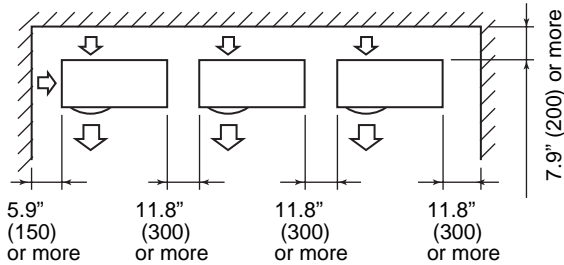

The height of the obstacle should be lower than the height of the outdoor unit.

Barrier also above unit

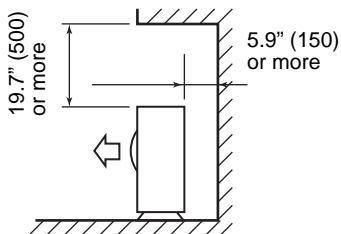

Barrier in front

Above unit is free

1. Single unit installation

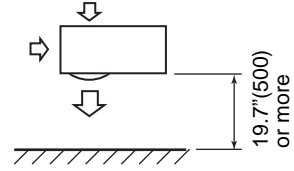

2. Multiple units installation

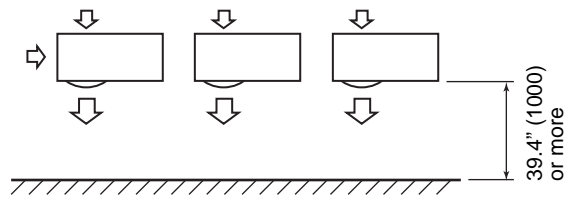

Barrier also above unit

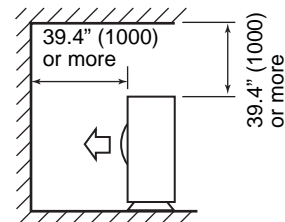

Barriers in front and back of unit

Open above and to the right and left of the unit. The height of an barrier in both the front and rear of the unit, should be lower than the height of the outdoor unit.

▼ Standard installation

1. Single unit installation

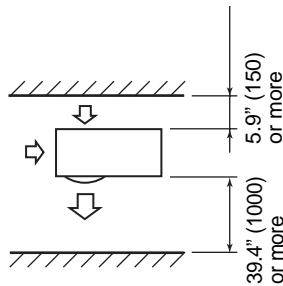

2. Multiple unit installation

a. Intake and supply parallel

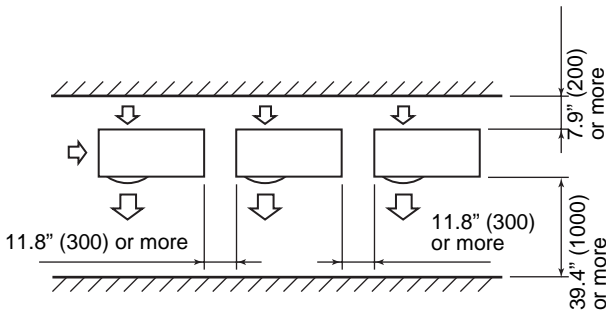

b. Intake and supply in line

Open above and to the right and left of the unit. The height of an obstacle in both the front and rear of the unit should be lower than the height of the outdoor unit.

▼ Standard installation

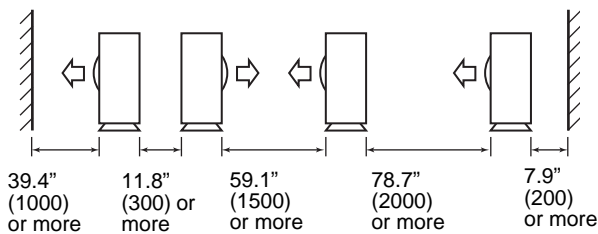

■ Installation of Outdoor Unit

- Before installation, check the strength and horizontal of the base so that abnormal sounds do not emanate.
- According to the following base diagram, fix the base firmly with the anchor bolts. (Anchor bolt, nut: 3/8" (M10) x 4 pairs)

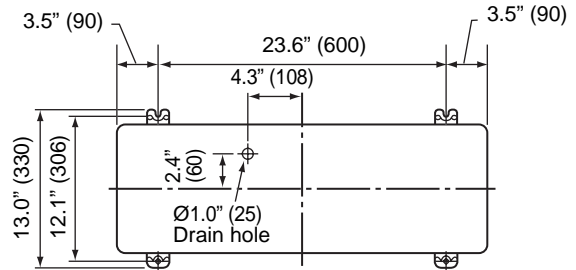

- 1) Field fabricate a snow or an ice stand for the unit using the above dimension.
- 2) Place snow or ice stand on a foundation/pad and secure it to the foundation/pad and secure it to the foundation/pad by anchor bolts.

NOTE

When the outdoor unit is anchored directly on the foundation/pad (cooling only protrude a minimum of 0.6" (15 mm)).

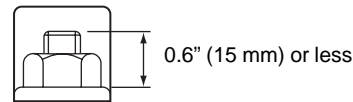

- 3) Place unit on stand. Make sure it is level and fasten securely to the stand.

 - As shown in the figure below, install the foundation and vibration-proof rubber pads to directly support the bottom surface of the fixing leg that is in contact with the bottom plate of the outdoor unit.
 - When installing the foundation for an outdoor unit with downward piping, consider the piping work.

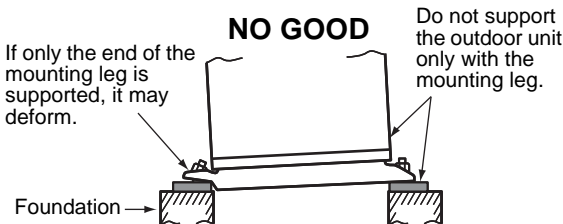
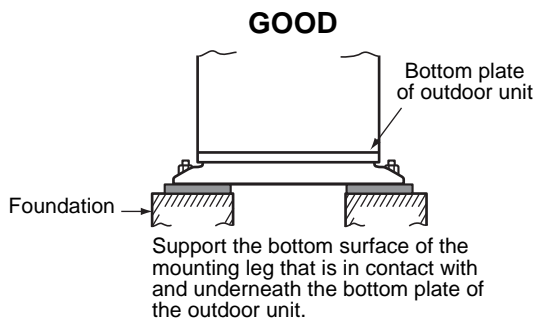
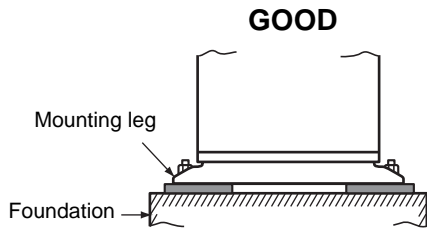

- When water is to be drained through the drain hose, attach the following drain nipple and waterproof rubber cap, and use the drain hose (Inner diameter: 0.6" (16 mm)) sold on the market. Also seal the screws securely with silicone material, etc., to prevent water from leaking. Some conditions may cause condensation or dripping of water.
- When collectively draining discharged water completely, use a drain pan.

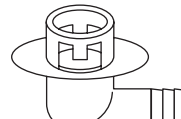

Drain nipple

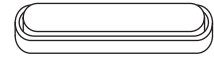

Waterproof rubber cap (2pcs.)

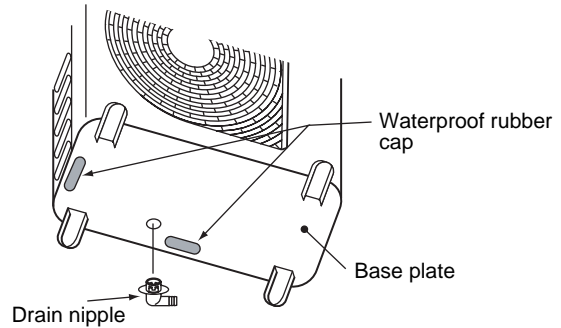

■ For Reference

If a heating operation is to be continuously performed for a long time under the condition that the outdoor temperature is 32 °F (0 °C) or lower, draining defrosted water may be difficult due to the bottom plate freezing, resulting in trouble with the cabinet or fan.

6 REFRIGERANT PIPING

⚠ CAUTION

TAKE NOTE OF THESE 4 IMPORTANT POINTS BELOW FOR PIPING WORK

1. Keep dust and moisture away from inside the connecting pipes.
2. Tightly connect the connection between pipes and the unit.
3. Evacuate the air in the connecting pipes using a VACUUM PUMP.
4. Check for gas leaks at connected points.

Flaring

1. Cut the pipe with a pipe cutter.
Be sure to remove burrs that may cause a gas leak.
2. Insert the supplied flare nut into the pipe, and then flare the pipe.
As the flaring sizes of R410A differ from those of refrigerant R22, the flare tools newly manufactured for R410A are recommended.

However, the conventional tools can be used by adjusting the projection margin of the copper pipe.

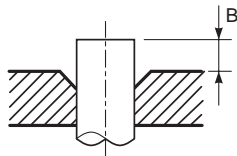

▼ Projection margin in flaring : B (Unit : in (mm))
Rigid (Clutch type)

Outer diameter of copper pipe	R410A tool used	Conventional tool used
	R410A	
1/4" (6.4)	0 - 0.02" (0 - 0.5)	0.04" - 0.06" (1.0 - 1.5)
1/2" (12.7)		

▼ Flaring diameter size : A (Unit : in (mm))

Outer diameter of copper pipe	A ⁺⁰ _{-0.02} (-0.4)
1/4" (6.4)	0.39" (9.9)
1/2" (12.7)	0.65" (16.6)

* In case of flaring for R410A with the conventional flare tool, pull the tool out approx. 0.02" (0.5 mm) more than that for R22 to adjust it to the specified flare size. The copper pipe gauge is useful for adjusting the projection margin size.

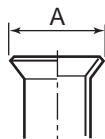

■ Tightening of Flare Connections

1. Align the centers of the flare connections and fully tighten the flare nuts with your fingers.

Valve at liquid side

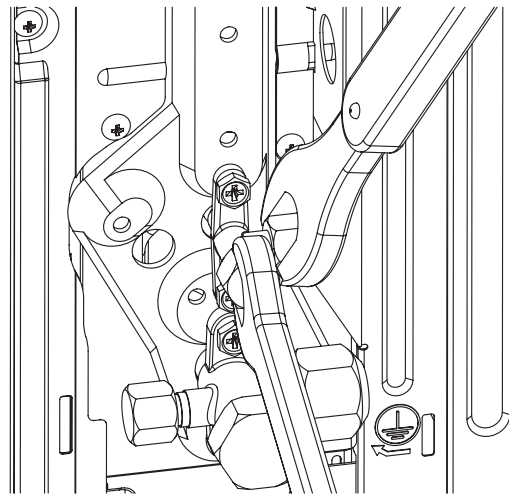

2. Use two wrenches to loosen or tighten the flare nut on the gas service valve as shown in the figure. Use only one wrench to loosen or tighten the flare nut on the liquid service valve. The final tightening with a torque wrench should be to the specifications shown in table below.

Unit : ft•lbs (N•m)

Outer diameter of copper pipe	Tightening torque
1/4" (6.4 mm)	10 - 13 (14 - 18)
1/2" (12.7 mm)	37 - 46 (50 - 62)

Valve at gas side

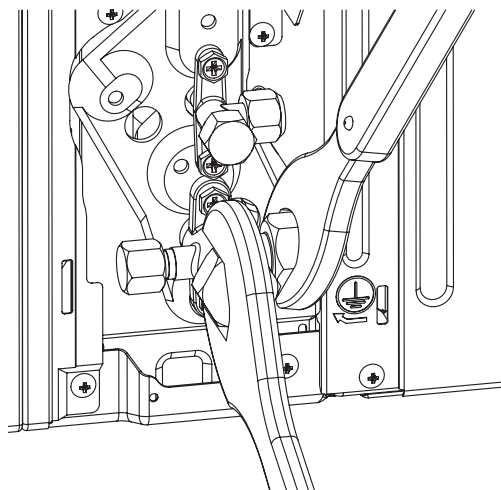

- After the installation work, be sure to check for gas leaks of the pipe connections with nitrogen.

NO GOOD

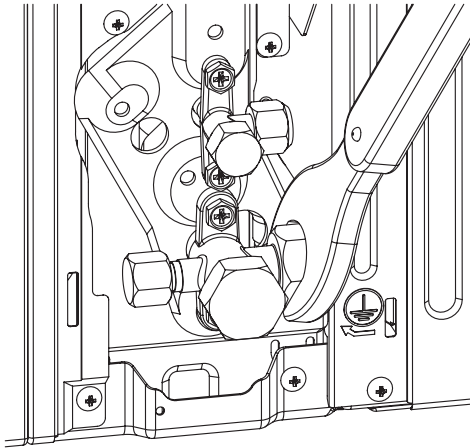

 **CAUTION**

1. Do not put the crescent wrench on the charge orifice or cover.
The valve may be broken.
2. If applying excessive torque, the nut may break according to some installation conditions.

- Pressure of R410A is higher than that of R22 (Approx. 1.6 times).
Therefore, using a torque wrench, tighten the flare pipe connecting sections that connect the indoor/outdoor units at the specified tightening torque.
Incomplete connections may cause not only a gas leak, but also trouble with the refrigeration cycle.

Do not apply refrigerant oil to the flared surface.

7 ELECTRICAL CONNECTIONS

⚠ WARNING

ELECTRICAL SHOCK HAZARD

Failure to follow this warning could result in personal injury or death.

- The unit cabinet must have an uninterrupted or unbroken ground to minimize personal injury if an electrical fault should occur. The ground may consist of electrical wire or metal conduit when installed in accordance with existing electrical codes.
- Before performing service or maintenance, be sure main power switch is turned OFF.

⚠ CAUTION

UNIT DAMAGE HAZARD

Failure to follow this caution may result in damage or improper operation.

- Unit failure as a result of operation on improper line voltage or excessive phase imbalance constitutes abuse and may cause damage to electrical components.
- Wrong wiring may cause a burn-out of some electrical parts.
- Do not damage or scratch the conductive core or inner insulator of the power and inter-connecting wires when peeling them.

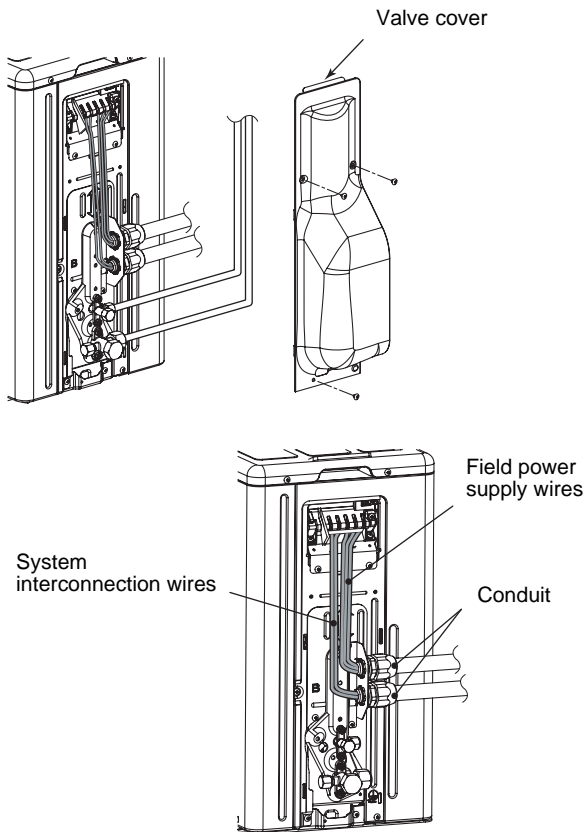

■ Field wiring

The dashed lines show field wiring.

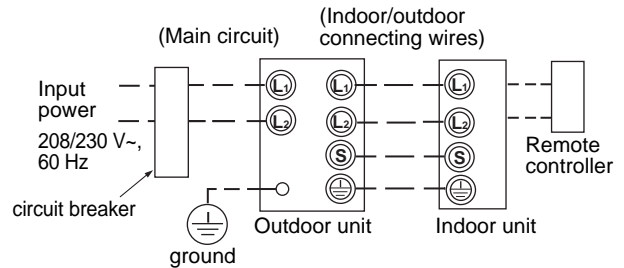

- Connect the indoor/outdoor connecting wires to the identical terminal numbers on the terminal block of each unit. Incorrect connection may cause a failure.

1. With the valve cover removed the electrical control box is exposed the side of the unit.
2. Terminate the field wiring conduit (if used) at the conduit connection holes provided.
3. Route the field power wires and the system interconnection wires (indoor to outdoor). Terminate the wires at field wiring terminal blocks.

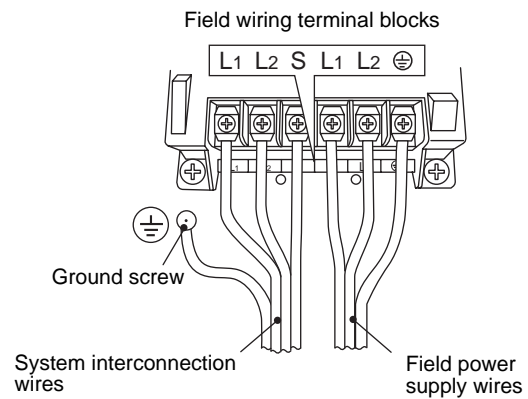

■ Wiring

All wiring and connections must comply with NEC, CEC, local codes.

1. Connect all wires to the correct terminal on the wiring terminal blocks.
2. Make sure that all connectors are secure.
3. Size connectors per the ratings listed in the system requirement section.
4. System interconnections should be minimum, 16 AWG.

8 EVACUATE AND DEHYDRATE THE SYSTEM

CAUTION

UNIT DAMAGE HAZARD

Failure to follow this caution may result in equipment damage or improper operation.
Never use the system compressor as a vacuum pump.

Refrigerant tubes and indoor heat exchanger should be evacuated using the recommended deep vacuum method of 500 microns. The alternate triple evacuation method may be used if the procedure outlined below is followed. Always break a vacuum with dry nitrogen.

SYSTEM VACUUM AND CHARGE

Using Vacuum Pump

1. Completely tighten flare nuts A, B, C, D, connect manifold gage charge hose to a charge port of the low side service valve.

Service Valve

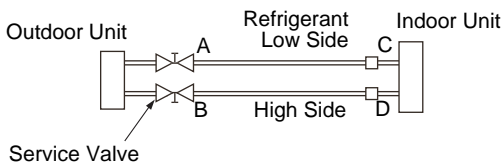

2. Connect charge hose to vacuum pump.
3. Fully open the low side of manifold gage.

Manifold

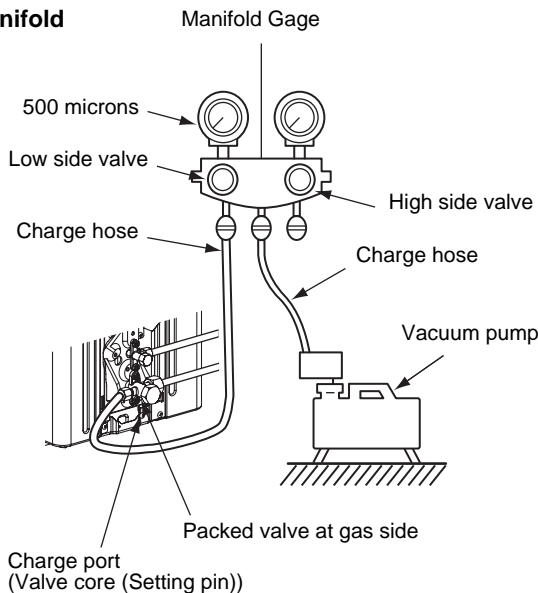

4. Start vacuum pump.

5. Evacuate using either deep vacuum or triple evacuation method.
6. After evacuation is complete, fully close the low side of manifold gage and stop operation of vacuum pump.

Deep Vacuum Method

The deep vacuum method requires a vacuum pump capable of pulling a vacuum of 500 microns and a vacuum gage capable of accurately measuring this vacuum depth. The deep vacuum method is the most positive way of assuring a system is free of air and liquid water.

Deep Vacuum Graph

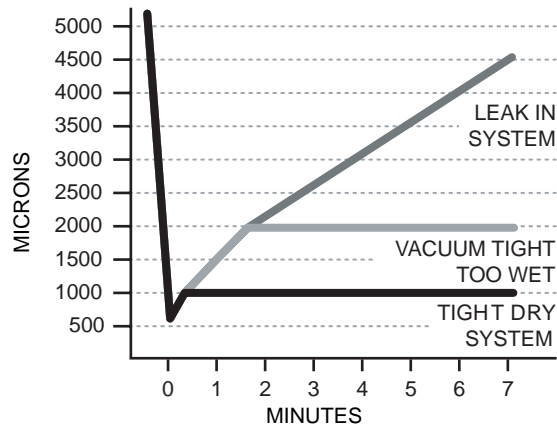

Triple Evacuation Method

The triple evacuation method should only be used when vacuum pump is only capable of pumping down to 28 in. of mercury vacuum and system does not contain any liquid water.

Refer to "Triple Evacuation Method chart" and proceed as follows:

1. Pump system down to 28 in. of mercury and allow pump to continue operating for an additional 15 minutes.
2. Close service valves and shut off vacuum pump.
3. Connect a nitrogen cylinder and regulator to system and open until system pressure is 2 psig.
4. Close service valve and allow system to stand for 1 hr. During this time, dry nitrogen will be able to diffuse throughout the system absorbing moisture.
5. Repeat this procedure as indicated in the chart. System will then be free of any contaminants and water vapor.

Triple Evacuation Method chart

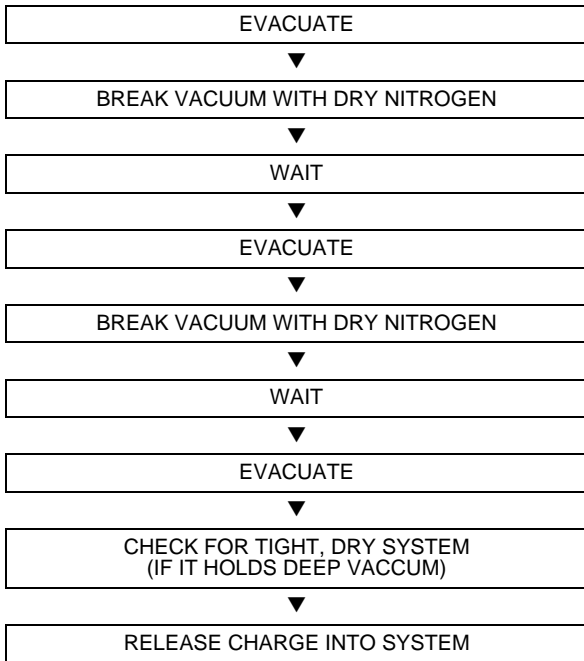

Final Tubing Check

IMPORTANT:

Check to be certain factory tubing on both indoor and outdoor unit has not shifted during shipment. Ensure tubes are not rubbing against each other or any sheet metal. Pay close attention to feeder tubes, making sure wire ties on feeder tubes are secure and tight.

Open service valves

Open or close the valve.

▼ Liquid and gas side

Open the valve with a **4 mm** hexagon wrench.

[Hexagonal wrench is required.]

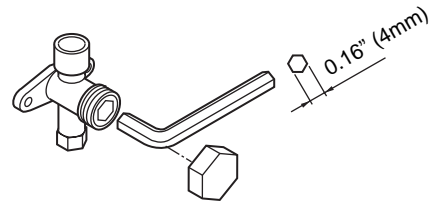

- While the valve is fully opened, after the screwdriver has reached the stopper, do not apply torque exceeding 4 ft•lbs (5 N•m). Applying excessive torque may damage the valve.

Valve handling precautions

- Open the valve stem until it reaches the stop. It is unnecessary to apply further force.
- Securely tighten the cap with a torque wrench.
- Cap tightening torque

Valve size	Ø1/4" (6.4 mm)	10 - 13 ft•lbs (14 - 18 N•m)
	Ø1/2" (12.7 mm)	24 - 31 ft•lbs (33 - 42 N•m)
Charge port		10 - 13 ft•lbs (14 - 18 N•m)

9 FINISHING

After the refrigerant pipe, inter-unit wires, and drain pipe have been connected, make sure they are supported and fixed in place for the entire length.

Keep the power wires and system interconnection wires away from all factory wiring and piping.

10 TEST RUN

- **Turn on the circuit breaker at least 12 hours before starting the system to preheat the compressor and prevent damage.**
To protect the compressor, power is supplied from the 208/230 VAC input to the unit to preheat the compressor.
- **Check the following before starting a test run:**
 - **That all pipes are connected securely without leaks.**
 - **That the valve is open.**
If the compressor is operated with the valve closed, the outdoor unit will become over pressurized, which may damage the compressor or other components.
If there is a leak at a connection, air can be sucked in and the internal pressure further increases, which may cause a burst or injury.
- Operate the air conditioner using the correct procedure as specified in the Owner's Manual.

11 PERIODIC MAINTENANCE

- For an air conditioning system that is operated on a regular basis, cleaning and maintenance of the indoor/outdoor units are strongly recommended.
As a general rule, if an indoor unit is operated for about 8 hours daily, the indoor/outdoor units will need to be cleaned at least once every 3 months. This cleaning and maintenance should be carried out by a qualified service person.
Failure to clean the indoor/outdoor units regularly will result in poor performance, icing, water leaking and even compressor failure.

12 UNIT PUMP DOWN

- Use the refrigerant recovery switch on the terminal block of the outdoor units to pump down the unit.

Procedure

1. Start cooling operation for a while, and then stop the operation.
2. Turn on the power of the air conditioner.
3. Select the FAN mode for indoor unit operation with the remote controller.
4. Press refrigerant recovery switch for 2 seconds or more. The air conditioner enters the forced cooling mode for up to 10 minutes.
Pump down the unit during this 10 minutes.
5. Upon completion of pump down the unit, close the valve and press refrigerant recovery switch for at least 2 second to stop operation.
6. Turn off the power.

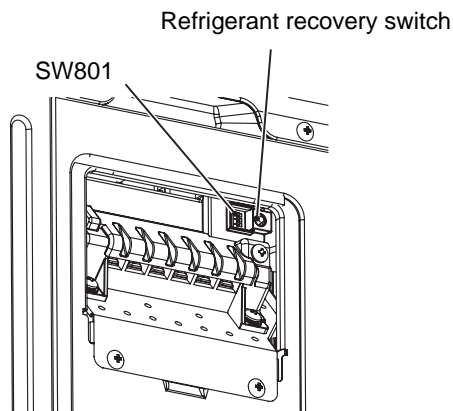

! DANGER

Be careful of electric shock because the P.C. board has an electrical current running through it.

13 POWER SAVE

- Power save can be set by setting SW801 dip switch.

Procedure

1. Turn on the SW801 dip switch 2 to activate Power save.

Power save controls reducing compressor periodicity (by approx. 10%) depending on the indoor unit heat exchanger temperature in heating operation

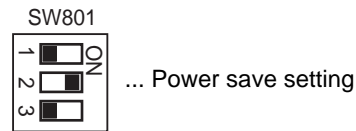

- * All switches are OFF as factory default.

! CAUTION

Do not touch SW801 dip switch 1, 3.
If any changes are made, the unit may not work properly.

