



TOSHIBA

Carrier

AIR CONDITIONER (SPLIT TYPE)

Installation Manual



Indoor Unit

Model name:

4-way Air Discharge Cassette Type

RAV-SP180UT-UL

RAV-SP240UT-UL

RAV-SP300UT-UL

RAV-SP360UT-UL

RAV-SP420UT-UL

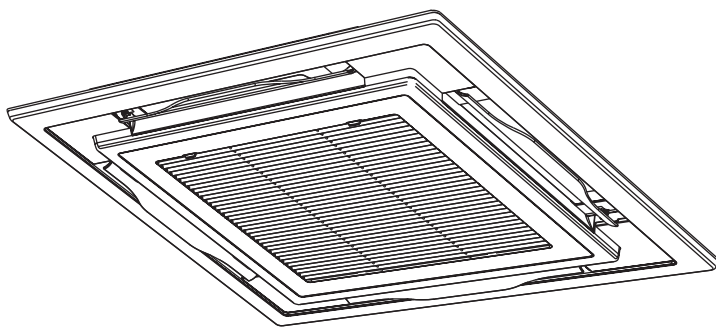

Installation Manual
Air conditioner (Split type)

1 English

Manuel du propriétaire
Climatiseur (Type split)

37 Français

Please read this Installation manual carefully before installing the Air Conditioner.

- This Manual describes the installation method of the indoor unit.
- For installation of the outdoor unit, follow the Installation Manual attached to the outdoor unit.

ADOPTION OF NEW REFRIGERANT









This Air Conditioner uses R410A an environmentally friendly refrigerant.

Contents

1	ACCESSORY PARTS.....	2
2	PRECAUTIONS FOR SAFETY.....	3
3	SELECTION OF INSTALLATION PLACE.....	5
4	INSTALLATION.....	9
5	DRAIN PIPING WORK.....	13
6	REFRIGERANT PIPING AND EVACUATING.....	16
7	ELECTRICAL CONNECTION.....	19
8	APPLICABLE CONTROLS.....	22
9	TEST RUN.....	31
10	TROUBLESHOOTING.....	33

1 ACCESSORY PARTS

■ Accessory parts

Part name	Q'ty	Shape	Usage
Installation Manual	2	These manual	(Be sure to hand over to customers)
Heat insulating pipe	2		For heat insulation of pipe connecting section
Installation pattern	1	—	For confirmation of ceiling opening and indoor unit position
Installation gauge	--		For positioning of ceiling position
Washer	4		For hanging-down unit
Eccentric washer	4		For hanging-down unit
Hose band	1		For connecting drain pipe
Heat insulator	1		For heat insulation of drain connecting section
Flexible hose	1		For adjusting center of drain pipe
Owner's Manual	1		(Be sure to hand over to customers)

■ Separate sold parts

- The Ceiling panel and remote control are sold separately. For the installation of these products, follow the Installation Manuals supplied with them.
- The wireless type remote control is designed to be installed by attaching a wireless remote controller kit (sold separately) to the standard panel. (The wireless remote controller kit consists of a wireless remote control and adjust corner caps with a signal receiving unit.)

2 PRECAUTIONS FOR SAFETY

Installing, starting up, and servicing air-conditioning equipment can be hazardous due to system pressures, electrical components, and equipment location (roofs, elevated structures, etc.).

Only trained, qualified installers and service mechanics should install, start-up, and service this equipment.

Untrained personnel can perform basic maintenance functions such as cleaning heat exchanger. All other operations should be performed by trained service personnel.

When working on the equipment, observe precautions in the literature and on tags, stickers, and labels attached to the equipment.

Follow all safety codes. Wear safety glasses and work gloves. Keep quenching cloth and fire extinguisher nearby when brazing. Use care in handling, rigging, and setting bulky equipment.

Read these instructions thoroughly and follow all warnings or cautions included in literature and attached to the unit. Consult local building codes and National Electrical Code (NEC) for special requirements. Recognize safety information. This is the safety-alert symbol . When you see this symbol on the unit and in instructions or manuals, be alert to the potential for personal injury. Understand these signal words: DANGER, WARNING, and CAUTION. These words are used with the safety-alert symbol.

DANGER identifies the most serious hazards which will result in severe personal injury or death. WARNING signifies hazards which could result in personal injury or death. CAUTION is used to identify unsafe practices which may result in minor personal injury or product and property damage. NOTE is used to highlight suggestions which will result in enhanced installation, reliability, or operation.

WARNING

- **Ask an authorized dealer or qualified installation professional to install (including moving)/maintain the air conditioner.**
Inappropriate installation may result in water leakage, electric shock or fire.
- **Be sure to connect ground wire. (grounding work)**
Incomplete grounding cause an electric shock.
Do not connect ground wires to gas pipes, water pipes, lightning rods or ground wires for telephone wires.
- **Turn off the circuit breaker before attempting any electrical work.**
Make sure all circuit breaker is off. Failure to do so may cause electric shock.
- **Install the refrigerant pipe securely during the installation work before operating the air conditioner.**
If the air conditioner is operated with the valve open and without the refrigerant pipe, the compressor sucks air and the refrigeration cycle is overpressurized, which may cause a burst or injury.
- **When moving the air conditioner for the installation into another place, be very careful not to enter any gaseous matter other than the specified refrigerant into the refrigeration cycle.**
If air or any other gas is mixed in the refrigerant, the gas pressure in the refrigeration cycle becomes abnormally high and it resultingly causes pipe burst and injuries on persons.
- **Perform installation work properly according to the Installation Manual.**
Inappropriate installation may result in water leakage, electric shock or fire.
- **When the air conditioner is installed in a small room, provide appropriate measures to ensure that the concentration of refrigerant leakage occur in the room does not exceed the critical level.**
- **Install the air conditioner securely in a location where the base can sustain the weight adequately.**
- **Perform the specified installation work to guard against an earthquake.**
If the air conditioner is not installed appropriately, accidents may occur due to the falling unit.
- **If refrigerant gas has leaked during the installation work, ventilate the room immediately.**
If the leaked refrigerant gas comes in contact with fire, noxious gas may generate.
- **After the installation work, confirm that refrigerant gas does not leak.**
If refrigerant gas leaks into the room and flows near a fire source, such as a cooking range, noxious gas might generate.
- **Electrical work must be performed by a qualified electrician in accordance with the Installation Manual. Make sure the air conditioner uses an exclusive power supply.**
An insufficient power supply capacity or inappropriate installation may cause fire.
- **Use the specified wires for wiring connect the terminals securely fix.**
To prevent external forces applied to the terminals from affecting the terminals.

- **Conform to the regulations of the local electric company when wiring the power supply.**
Inappropriate grounding may cause electric shock.
- **For the refrigerant recovery work (collection of refrigerant from the pipe to the compressor), stop the compressor before disconnecting the refrigerant pipe.**
If the refrigerant pipe is disconnected while the compressor is working with the valve open, the compressor sucks air and the refrigeration cycle is overpressurized, which may cause a burst or injury.

 **CAUTION**

- **THIS AIR CONDITIONER ADOPTS THE NEW HFC REFRIGERANT (R410A) WHICH DOES NOT DESTROY OZONE LAYER.**
 - The characteristics of R410A refrigerant are ; easy to absorb water, oxidizing membrane or oil, and its pressure is approx. 1.6 times higher than that of refrigerant R22. Accompanied with the new refrigerant, refrigerating oil has also been changed. Therefore, during installation work, be sure that water, dust, former refrigerant, or refrigerating oil does not enter the refrigerating cycle.
 - To prevent charging an incorrect refrigerant and refrigerating oil, the sizes of connecting sections of charging port of the main unit and installation tools are changed from those for the conventional refrigerant.
 - Accordingly the exclusive tools are required for the new refrigerant (R410A).
 - For connecting pipes, use new and clean piping designed for R410A, and please care so that water or dust does not enter.
 - **Tighten the flare nut with a torque wrench in the specified manner.**
Excessive tightening of the flare nut may cause a crack in the flare nut after a long period, which may result in refrigerant leakage.
 - **Wear heavy gloves during the installation work to avoid injury.**
 - **The installation fuse must be used for the power supply line of this conditioner.**
-

3 SELECTION OF INSTALLATION PLACE

WARNING

- **Install the air conditioner at enough strong place to withstand the weight of the unit.**
If the strength is not enough, the unit may fall down resulting in injury.
- **Install the air conditioner at a height 8' (2.4 m) or more from the floor.**
If you insert your hands or others directly into the unit while the air conditioner operates, it is dangerous because you may contact with revolving fan or active electricity.

CAUTION

- **Do not install the air conditioner in a location subject to a risk of exposure to a combustible gas.**
If a combustible gas leaks and stays around the unit, a fire may occur.

Upon approval of the customer, install the air conditioner in a place that satisfies the following conditions.

- Place where the unit can be installed horizontally.
- Place where a sufficient servicing space can be ensured for safety maintenance and check.
- Place where drained water will not cause any problem.

Avoid installing in the following places.

- Place exposed to air with high salt content (seaside area), or place exposed to large quantities of sulfide gas (hot spring).
(Should the unit be used in these places, special protective measures are needed.)
- A restaurant kitchen where a lot of oil is used or place near machines in a factory (Oil adhering to the heat exchanger and resin part (turbo fan) in the indoor unit may reduce the performance, generate mist or dew drop, or deform or damage resin parts.)
- Place where organic solvent is used nearby.
- Place close to a machine generating high frequency.
- Place where the discharged air blows directly into the window of the neighbor house. (Outdoor unit)
- Place where noise of the outdoor unit is easily transmitted.
(When install the outdoor unit on the boundary with the neighbor, pay due attention to the level of noise.)
- Place with poor ventilation. (Before air ducting work, check whether value of fan speed, static pressure and duct resistance are correct.)
- Do not use the air conditioner for special purposes such as preserving food, precision instruments, or art objects, or where breeding animals or growing plants are kept. (This may degrade the quality of preserved materials.)
- Place where any of high-frequency appliances (including inverter devices, private power generators, medical equipment, and communication equipment) and inverter-type fluorescent light is installed.
(A malfunction of the air conditioner, abnormal control, or problems due to noise to such appliances/equipment may occur.)
- When the wireless remote control is used in a room equipped with an inverter-type fluorescent light or at a place exposed to direct sunlight, signals from the remote control may not be received correctly.
- Place near a door or window exposed to humid outside air (Dew dropping may form.).
- Place where special spray is used frequently.

■ Installation space

Secure the specified space in the figure for installation and servicing.

Model RAV-	A in (mm)
SP180, SP240 Type	10.7" (271) or more
SP300, SP360, SP420 Type	13.1" (334) or more

unit : in (mm)

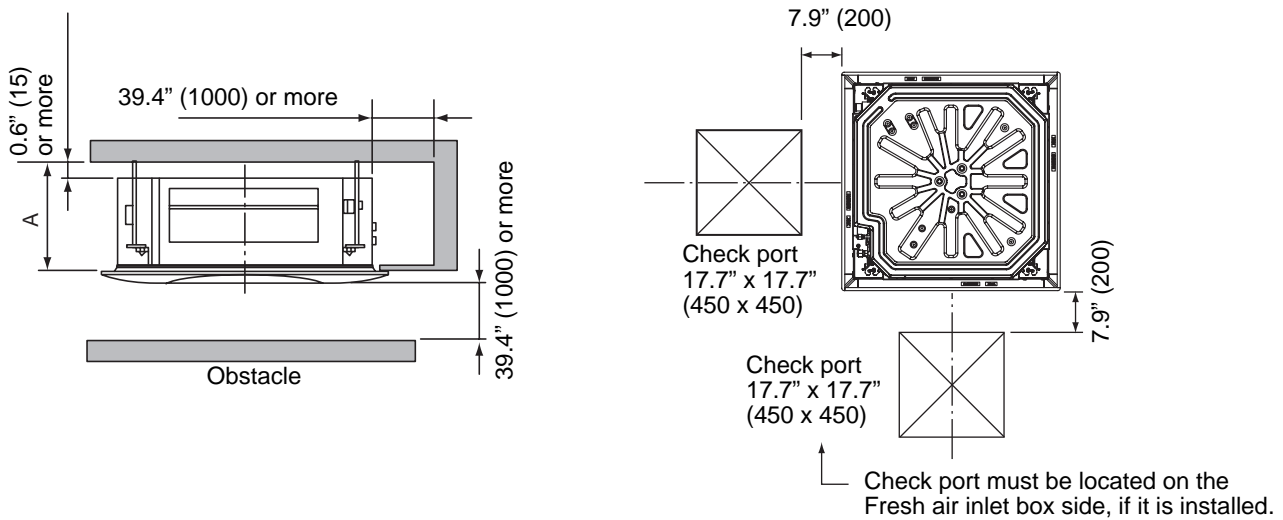

■ Selection of installation place

In case of continued operation of the indoor unit under high-humidity conditions as described below, dew may condense and water may drop.

Especially, high-humidity atmosphere (dew point temperature : 73.4°F (23°C) or more) may generate dew inside the ceiling.

1. Unit is installed inside the ceiling with slated roof.
2. Unit is installed at a location using inside of the ceiling as fresh air take-in path.
3. Kitchen

Advice

- Set a service check opening panel at right side of the unit (size: 17.7" x 17.7" (450 x 450mm) or more) for piping, maintenance, and servicing.
- If installing a unit at such place, put insulating material (glass wool, etc.) additionally on all the positions of the indoor unit which come to contact with high-humidity atmosphere.

REQUIREMENT

When the humidity inside the ceiling seems to be higher than 80%, attach a heat insulator to the side (top) surface of the indoor unit. (Use a heat insulator that is 0.4" (10 mm) or more thick.)

■ Ceiling height

Model RAV-	Possible installed ceiling height
SP180, SP240 Type	Up to 12'6" (3.8 m)
SP300, SP360, SP420 Type	Up to 15'1" (4.6 m)

When the height of the ceiling exceeds the distance of the item Standard/4-way in Table on the next page, the hot air is difficult to reach the floor.

Therefore, it is necessary to change the setup value of the high ceiling switch or discharge direction.

▼ Height list of ceiling possible to be installed

Unit : ft (m)

Model RAV-	SP180 Type			SP240 Type			SP300, SP360, SP420 Type			High ceiling setup	
	No. of discharge direction	4-way	3-way	2-way	4-way	3-way	2-way	4-way	3-way	2-way	Set data
Standard (Factory default)	9'2" (2.8)	10'6" (3.2)	11'6" (3.5)	9'10" (3.0)	10'10" (3.3)	11'10" (3.6)	12'10" (3.9)	13'9" (4.2)	14'9" (4.5)		0000
High ceiling (1)	10'6" (3.2)	11'6" (3.5)	12'6" (3.8)	10'10" (3.3)	11'6" (3.5)	12'6" (3.8)	13'9" (4.2)	14'5" (4.4)	15'1" (4.6)		0001
High ceiling (2)	11'6" (3.5)	12'6" (3.8)	—	11'10" (3.6)	12'6" (3.8)	—	14'9" (4.5)	15'1" (4.6)	—		0003

REQUIREMENT

- When using the air conditioner with 2-way/3-way discharge system, a strong wind blows directly if the ceiling height is lower than the standard.
Therefore, change the setting switch according to height of the ceiling.
- When using the high ceiling (1) or (2) with 4-way discharge system, the draft is apt to be felt due to drop of the discharge temperature.

The lighting time of the filter sign (notification of filter cleaning) on the remote control can be changed according to installation conditions.

When it is difficult to obtain satisfactory heating due to location place of the indoor unit or the structure of the room, the detection temperature of heating can be raised.

Refer to "8 Applicable Controls" in this manual for the setting procedure.

■ Discharge direction

As shown in the figure below, air discharge directions can be selected according to the shape of the room and the location of the indoor unit installation.

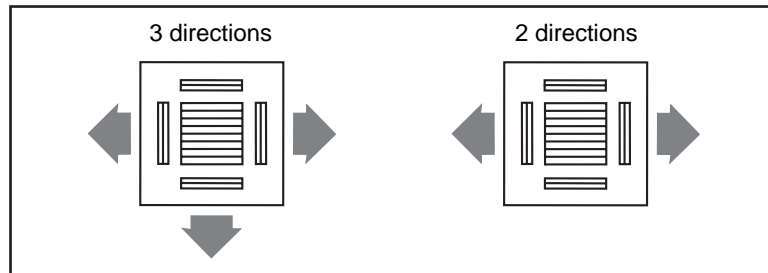

- Use a Air discharge direction kit (sold separately) to change discharge directions. Discharge directions are limited. Follow the Installation Manual supplied with the Air discharge direction kit.

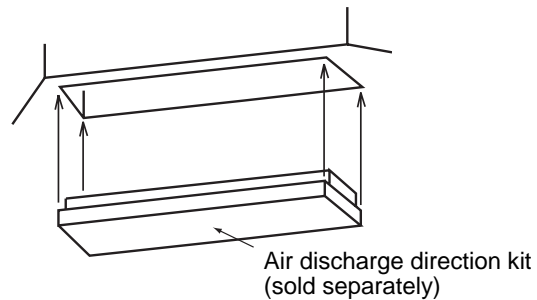

4 INSTALLATION

REQUIREMENT

Strictly comply with the following rules to prevent damage of the indoor units and human injury.

- Do not put a heavy article on the indoor unit. (Even units are packaged)
- Carry in the indoor unit as it is packaged if possible. If carrying in the indoor unit unpacked by necessity, be sure to use buffering cloth, etc. to not damage the unit.
- To move the indoor unit, hold the hooking metals (4 positions) only.
Do not apply force to the other parts (refrigerant pipe, drain pan, foamed parts, or resin parts, etc.).
- Carry the package by two or more persons, and do not bundle it with plastic band at positions other than specified.

External view

Unit : in (mm)

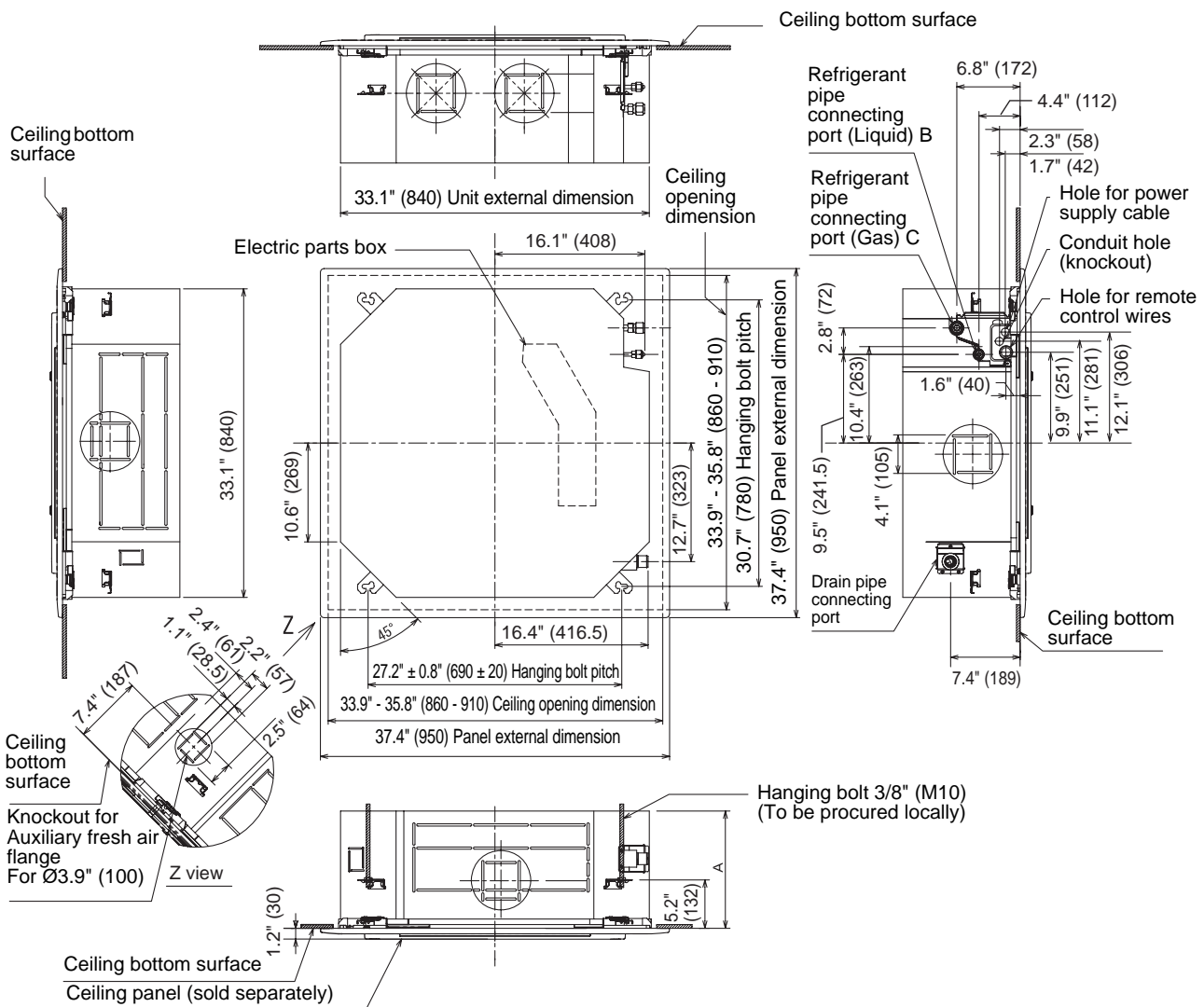

Unit : in (mm)

Model RAV	A	B	C	Model RAV	A	B	C
SP180 Type	10.1" (256)	Ø1/4" (6.4)	Ø1/2" (12.7)	SP360 Type	12.6" (319)	Ø3/8" (9.5)	Ø5/8" (15.9)
SP240 Type	10.1" (256)	Ø3/8" (9.5)	Ø5/8" (15.9)	SP420 Type	12.6" (319)	Ø3/8" (9.5)	Ø5/8" (15.9)
SP300 Type	12.6" (319)	Ø3/8" (9.5)	Ø5/8" (15.9)				

Opening a ceiling and installation of hanging bolts

- Consider the piping/wiring after the unit is hung when determining the location of the indoor unit installation and orientation.
- After the location of the indoor unit installation has been determined, open the ceiling and install hanging bolts.
- The dimensions of the ceiling opening and hanging bolt pitches are given in the outline drawing and the attached installation pattern.
- When a ceiling already exists, lay the drain pipe, refrigerant pipe, system interconnection wires, and remote control wires to their connection locations before hanging the indoor unit.

Procure hanging bolts and nuts for installing the indoor unit (these are not supplied).

Hanging bolt	3/8" (M10)	4 pieces
Nut	3/8" (M10)	12 pieces

Using the installation pattern (accessory)

The installation pattern is provided inside the packaging cap.

<For existing ceiling>

Use the installation pattern positioning a ceiling opening and hanging bolts.

<For new ceiling>

Use the installation pattern to position the ceiling opening when hanging a ceiling.

- After the hanging bolts have been installed, install the indoor unit.
- Hook the four holes in the installation pattern to the panel fixing screws of the indoor unit.
- When hanging a ceiling, open the ceiling along the outside dimensions of the installation pattern.

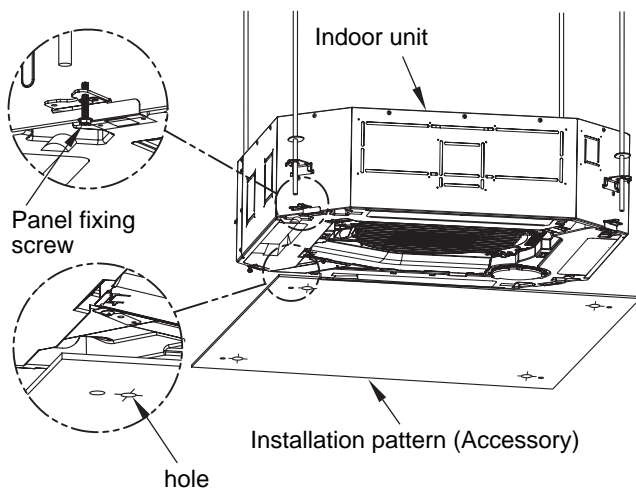

Treatment of ceiling

The ceiling differs according to structure of building. For details, consult your constructor or interior finish contractor.

In the process after the ceiling board has been removed, it is important to reinforce ceiling foundation (frame) and to keep horizontal level of installed ceiling correctly in order to prevent vibration of ceiling board.

- (1) Cut and remove the ceiling foundation.
- (2) Reinforce the cut surface of ceiling foundation, and add ceiling foundation for fixing the end of ceiling board.

Installation of hanging bolt

Use 3/8" (M10) hanging bolts (4 pcs, to be local procure). Matching to the existing structure, set pitch according to size in the unit external view as shown below.

<p>New concrete slab</p> <p>Install the bolts with insert brackets or anchor bolts.</p> <p>(Blade type bracket) (Slide type bracket) (Pipe hanging anchor bolt)</p>
<p>Steel frame structure</p> <p>Use existing angles or install new support angles.</p> <p>Hanging bolt, Hanging bolt, Support angle</p>
<p>Existing concrete slab</p> <p>Use a hole-in anchors, hole-in plugs, or a hole-in bolts.</p>

Installation of ceiling opening and hanging bolt

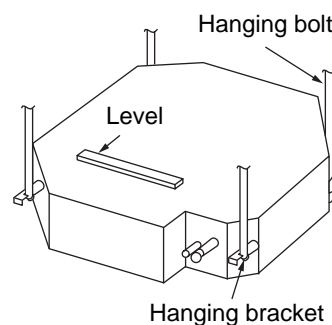

- Attach a nut (3/8" (M10): not supplied) and the Ø1.3" (34 mm) washer (supplied) to each hanging bolt.
 - Insert a washer on both sides of the T groove of the hanging bracket of the indoor unit, and hang the indoor unit.
 - Check that the four sides of the indoor unit are level using a level vial (levelness: 0.2" (5 mm) or less).
 - Detach the installation gauge (accessory) from the installation pattern.
 - Using the installation gauge, check and adjust the positional relation between the indoor unit and the ceiling opening (1) (0.4" - 1.4" (10 - 35 mm): 4 sides) and the hanging-up height (2) (0.5" - 0.7" (12 - 17 mm): 4 corners).
- (How to use the installation gauge is printed on the gauge.)

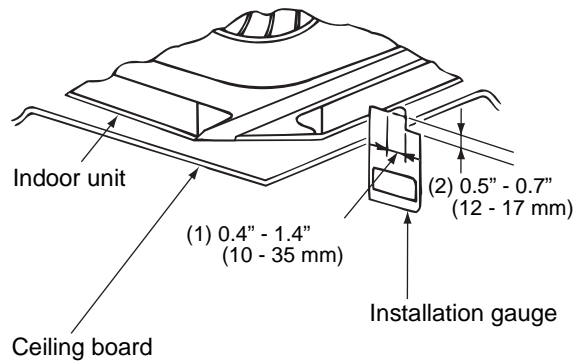

REQUIREMENT

Before installation of the indoor unit, be sure to remove the cushion for transportation between the fan and the bell mouth. Running the unit without removing the cushion may damage the fan motor.

Remove the 5 screws and detach the wire guard. Remove the cushion placed between fan and bell mouth. Attach back the wire guard.

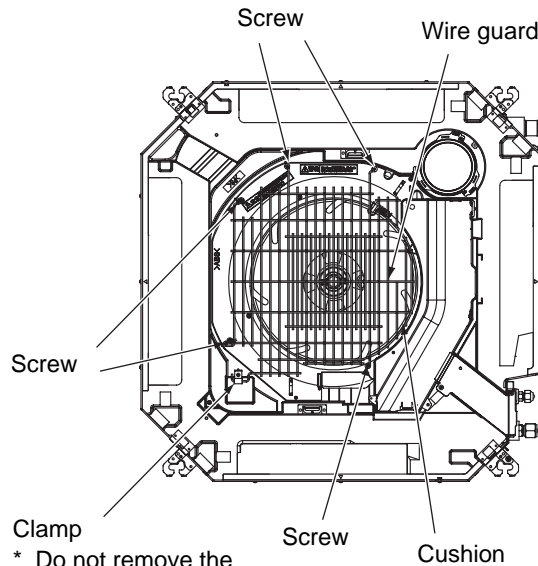
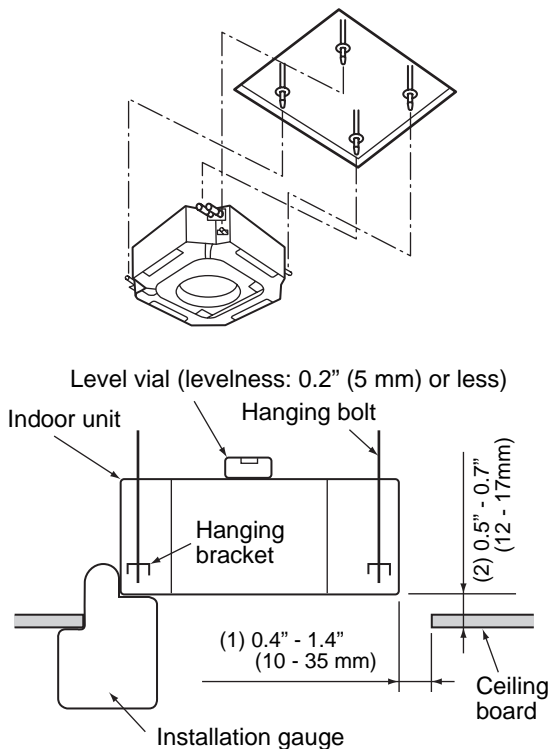
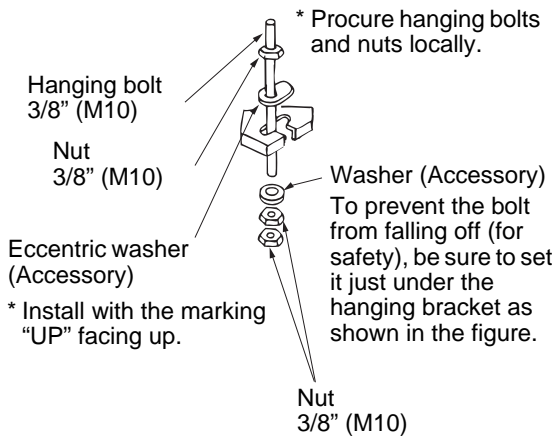

* Do not remove the clamp fixing screw on the indoor unit.

■ Installation of ceiling panel (Sold separately)

Install the ceiling panel according to Installation Manual attached with it after piping/wiring work has completed.

Check that installation of indoor unit and ceiling opening part is correct, and then install it.

REQUIREMENT

- Joint the connecting sections of ceiling panel, ceiling surface, ceiling panel and indoor unit closely. Any gap between them will cause air leakage and the generate condensation or water leakage.
- Remove the adjust corner caps at the four corners of the ceiling panel, and then install the ceiling panel onto the indoor unit.
- Make sure that the claws of the four adjust corner caps are securely fit.
 - * Improper fitting of the claws may cause water leakage.

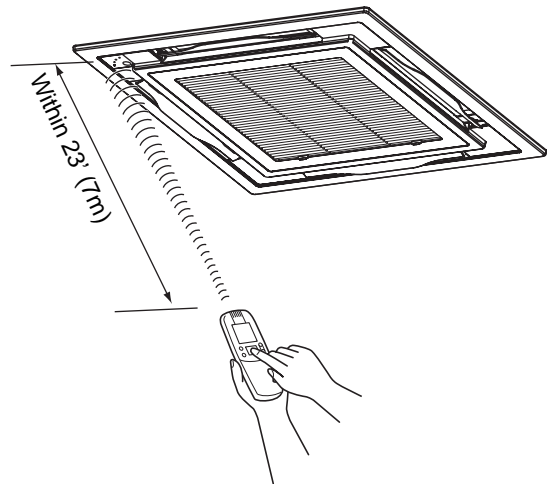

■ Installation of remote control (Sold separately)

For installation of the wired remote control, follow the Installation Manual attached with the remote control.

- Pull out the remote control cord together with the refrigerant pipe or drain pipe.
 - Be sure to pass the remote control cord through upper side of the refrigerant pipe and drain pipe.
- Do not leave the remote control at a place exposed to the direct sunlight and near a stove.

■ Wireless remote control

The sensor of indoor unit with wireless remote control can receive a signal by distance within approx. 23' (7 m). Based upon it, determine a place where the remote control is operated and the installation place.

- Operate the remote control, confirm that the indoor unit receives a signal surely, and then install it.
- Keep 3'3" (1 m) or more from the devices such as television, stereo, etc.
 - (Disturbance of image or noise may generate.)
- To prevent a malfunction, select a place where is not influenced by a fluorescent light or direct sunlight.
- Two or more (Up to 6 units) indoor units with wireless type remote control can be installed in the same room.

5 DRAIN PIPING WORK

⚠ CAUTION

- Following the Installation Manual, perform the drain piping work so that water is properly drained, and apply a heat insulation so as not to cause a dew dropping. Inappropriate piping work may result in water leakage in the room and wet of furniture.

■ Piping/Heat insulating material

Require the following materials for piping and heat insulating at site.

Piping	Hard vinyl chloride pipe VP25 (Outer dia. : Ø1.3" (32 mm))
Heat insulator	Foam polyethylene : Thickness 0.4" (10 mm) or more

■ Flexible hose

Use the attached flexible hose to adjust center discrepancy of the hard vinyl chloride pipe or to adjust the angle.

- Do not use the flexible hose as stretched, or do not deform it more extent than that in the following figure.
- Be sure to fix the soft end of the flexible hose with the attached hose band.
- Use the flexible hose on a horizontal level.

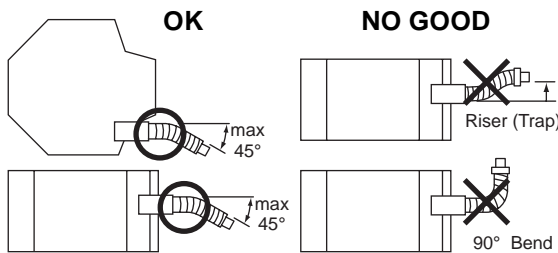

REQUIREMENT

- Be sure to perform heat insulation of the drain pipes of the indoor unit.
- Never forget to perform heat insulation of the connecting part with the indoor unit. An incomplete heat insulation causes dew dropping.
- Set the drain pipe with downward slope (1/100 or more), and do not make swelling or trap on the piping. It may cause an abnormal sound.

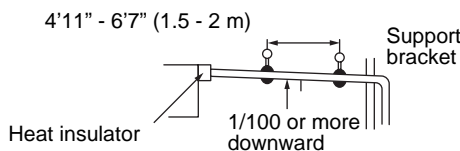

- For length of the traversing drain pipe, restrict to 65'7" (20 m) or less. In case of a long pipe, provide support brackets with interval of 4'11" - 6'7" (1.5 - 2 m) in order to prevent waving.

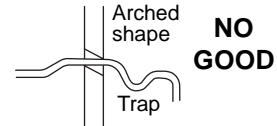

- Set the collective piping as shown in the below figure.

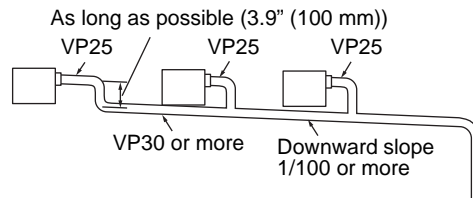

- Be sure not to apply force to the connecting part of the drain pipe.
- The hard vinyl-chloride pipe cannot be directly connected to the drain pipe connecting port of the indoor unit.

For connection with the drain pipe connecting port, be sure to use/fix the attached flexible hose with the hose band, otherwise a damage or water leak is caused on the drain pipe connecting port.

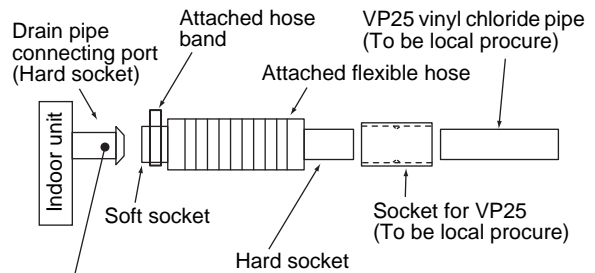

Adhesive inhibited :

Use the attached flexible hose and hose band for connecting the drain hose to the clear drain socket. If applying the adhesive, socket will be damaged and cause water leakage.

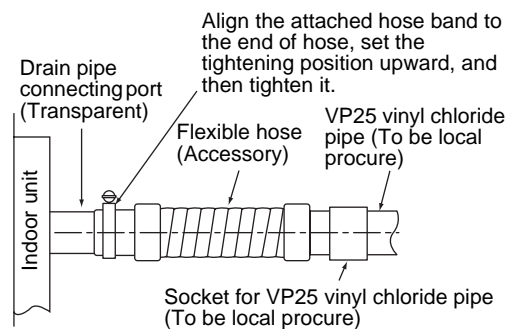

■ Connecting drain pipe

- Connect a hard socket (procured locally) to the hard socket of the attached supplied flexible hose.
- Connect a drain pipe (procured locally) to the connected hard socket.

REQUIREMENT

- Connect hard vinyl chloride pipes securely using an adhesive for vinyl chloride to avoid water leakage.
- It takes some time until the adhesive is dried and hardened (refer to the manual of the adhesive). Do not apply stress to the joint with the drain pipe during this time period.

■ Drain up

When a down-gradient cannot be secured for the drainpipe, drain-up piping is possible.

- The height of the drain pipe must be 33.5" (850 mm) or less from the bottom of the ceiling.
- Take the drain pipe out of the drain pipe joint with the indoor unit in 11.8" (300 mm) or less, and bend up the pipe vertically.
- Immediately after the pipe is bent up vertically, lay the pipe making a down-gradient.
- Set downward grading immediately after raising up vertically.

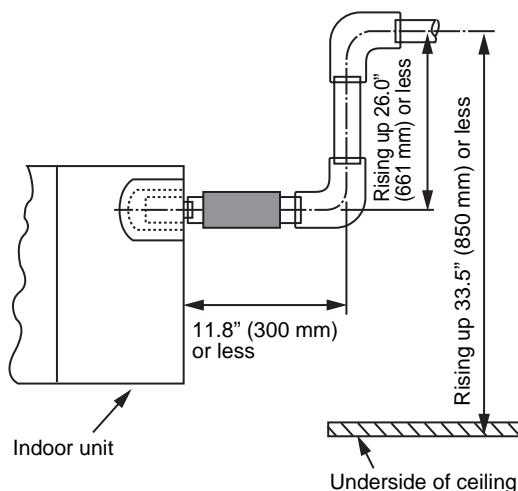

■ Check the draining

In the test run, check that water drain is properly performed and water does not leak from the connecting part of the pipes.

Be sure to check draining also when installed in heating period.

Using a pitcher or hose, pour water (0.4 - 0.5 gal (1500 - 2000 cc)) into the discharge port before installation of the ceiling panel.

Pour water gradually so that water does not spread on the motor of the drain pump.

⚠ CAUTION

Pour water gently so that it does not spread around inside the indoor unit, which may cause a malfunction.

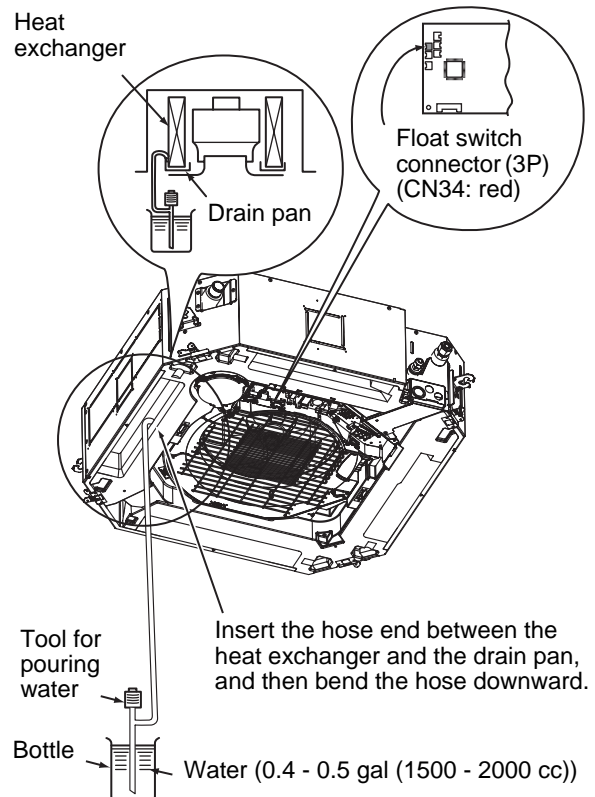

- After the electric work has finished, pour water during COOL mode operation.
- If the electric work has not yet finished, pull out the float switch connector (CN34 : Red) from the electric parts box, and check draining by plugging the single phase 208/230 V power to the terminal blocks L1 and L2. If doing so, the drain pump motor operates.
- Test water drain while checking the operation sound of the drain pump motor. (If the operation sound changes from continuous sound to intermittent sound, water is normally drained.) After the check, the drain pump motor runs, connecting the float switch connector. (In case of check by pulling out the float switch connector, be sure to return the connector to the original position.)

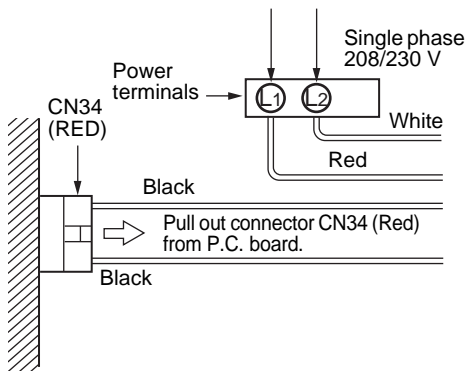

■ Perform heat insulating

- As shown in the figure, cover the flexible hose and hose band with the attached heat insulator up to the bottom of the indoor unit without gap.
- Cover the drain pipe seamlessly with a heat insulator to be procured locally so that it overlaps with the attached heat insulator of the drain connecting section.

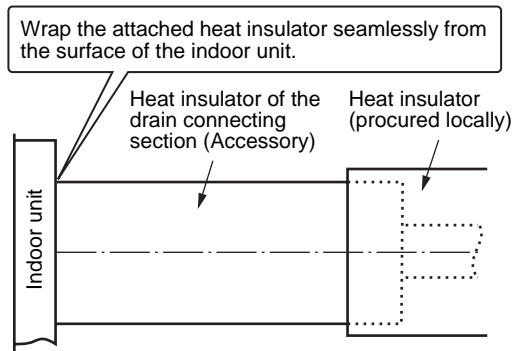

- * Direct the slits and seams of the heat insulator upward to avoid water leakage.

6 REFRIGERANT PIPING AND EVACUATING

Refrigerant Piping

- If the outdoor units are to be mounted on a wall, make sure that the supporting platform is sufficiently strong. The platform should be designed and manufactured to maintain its strength over a long period of time, and sufficient consideration should be given to ensuring that the outdoor unit will not fall.
- Use copper pipe with 0.03" (0.8 mm) or more thickness.** (In case pipe size is $\text{Ø}5/8"$ (15.9 mm), with 0.04" (1.0 mm) or more.)
- Flare nut and flare works are also different from those of the conventional refrigerant. Take out the flare nut attached to the main unit of the air conditioner, and use it.

REQUIREMENT

When the refrigerant pipe is long, provide support brackets at intervals of 8'2" - 9'10" (2.5 - 3 m) to clamp the refrigerant pipe. Otherwise, abnormal sound may be generated.

CAUTION

IMPORTANT 4 POINTS FOR PIPING WORK

- Remove dust and moisture from the inside of the connecting pipes.
- Tight connection (between pipes and unit)
- Evacuate the air in the connecting pipes using VACUUM PUMP.
- Check the gas leakage. (Connected points)

Pipe size

Model name	RAV-	SP180 type	SP240, SP300, SP360, SP420 type
Pipe size	Gas side	1/2" (12.7 mm)	5/8" (15.9 mm)
	Liquid side	1/4" (6.4 mm)	3/8" (9.5 mm)

Permissible Piping Length and Height Difference

They vary according to the outdoor unit. For details, refer to the Installation Manual attached to the outdoor unit.

Flaring

- Cut the pipe with a pipe cutter. Remove burrs completely. Remaining burrs may cause gas leakage.
- Insert a flare nut into the pipe, and flare the pipe. As the flaring sizes of R410A differ from those of refrigerant R22, the flare tools newly manufactured for R410A are recommended. However, the conventional tools can be used by adjusting projection margin of the copper pipe.

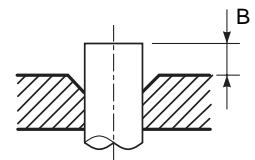

Projection margin in flaring : B (Unit : in (mm))

Rigid (Clutch type)

Outer dia. of copper pipe	R410A tool used	Conventional tool used
	R410A	R410A
1/4" (6.4), 3/8" (9.5)	0 - 0.02" (0 - 0.5)	0.06" - 0.08" (1.5 - 2.0)
1/2" (12.7), 5/8" (15.9)		0.08" - 0.1" (2.0 - 2.5)

Flaring dia. meter size : A (Unit : in (mm))

Outer dia. of copper pipe	A ⁺⁰ / _{-0.02} (-0.4)
	R410A
1/4" (6.4)	0.36" (9.1)
3/8" (9.5)	0.52" (13.2)
1/2" (12.7)	0.65" (16.6)
5/8" (15.9)	0.78" (19.7)

- * In case of flaring for R410A with the conventional flare tool, pull it out approx. 0.02" (0.5 mm) more than that for R22 to adjust to the specified flare size. The copper pipe gauge is useful for adjusting projection margin size.

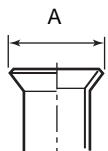

Tightening connection

CAUTION

- Do not apply excessive torque. Otherwise, the nut may crack depending on the conditions.

Unit : ft•lbs (N•m)

Outer dia. of copper pipe	Tightening torque
1/4" (6.4 mm)	10 - 13 (14 - 18)
3/8" (9.5 mm)	24 - 31 (33 - 42)
1/2" (12.7 mm)	37 - 46 (50 - 62)
5/8" (15.9 mm)	46 - 57 (63 - 77)

▼ Tightening torque of flare pipe connections

Pressure of R410A is higher than that of R22.

(Approx. 1.6 times)

Therefore, using a torque wrench, tighten the flare pipe connecting sections which connect the indoor and outdoor units of the specified tightening torque.

Incorrect connections may cause not only a gas leak, but also a trouble of the refrigeration cycle.

Align the centers of the connecting pipes and tighten the flare nut as far as possible with your fingers. Then tighten the nut with a spanner and torque wrench as shown in the figure.

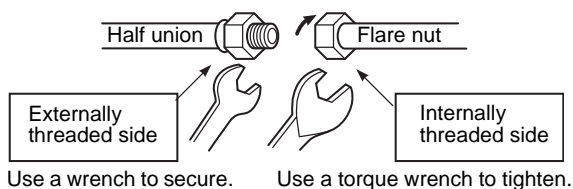
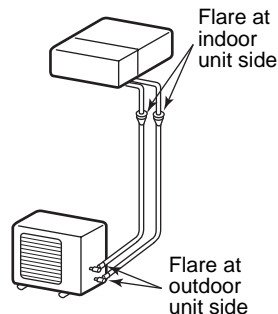

REQUIREMENT

Tightening with an excessive torque may crack the nut depending on installation conditions.

Tighten the nut within the specified tightening torque.

Piping with outdoor unit

- Shape of valve differs according to the outdoor unit. For details of installation, refer to the Installation Manual of the outdoor unit.

■ Evacuation

Using a vacuum pump, perform vacuuming from the charge port of valve of the outdoor unit.

For details, follow to the Installation Manual attached to the outdoor unit.

- Never use the refrigerant sealed in the outdoor unit for air purge.

REQUIREMENT

For the tools such as charge hose, etc., use those manufactured exclusively for R410A.

Refrigerant amount to be added

For addition of the refrigerant, add refrigerant "R410A" referring to the attached Installation Manual of outdoor unit.

Be sure to use a scale to charge the refrigerant of specified amount.

REQUIREMENT

- Charging an excessive or too little amount of refrigerant causes a trouble of the compressor. Be sure to charge the refrigerant of specified amount.
- A personnel who charged the refrigerant should write down the pipe length and the added refrigerant amount in the nameplate attached to the service panel of the outdoor unit. It is necessary to troubleshoot the compressor and refrigeration cycle malfunction.

Open the valve fully

Open the valve of the outdoor unit fully. A 4 mm hexagonal wrench is required for opening the valve.

For details, refer to the Installation Manual attached to the outdoor unit.

Gas leak check

Check with a leak detector or soap water whether gas leaks or not, from the pipe connecting section or cap of the valve.

REQUIREMENT

Use a leak detector manufactured exclusively for HFC refrigerant (R410A, R134a, etc.).

Thermal insulation process

Apply thermal insulation for the pipes separately at liquid side and gas side.

For the thermal insulation to the pipes at gas side, be sure to use the material with heat-resisting temperature 248 °F (120 °C) or higher.

Using the attached thermal insulation material, apply the thermal insulation to the pipe connecting section of the indoor unit securely without gap.

REQUIREMENT

- Apply the thermal insulation to the pipe connecting section of the indoor unit securely up to the root

without exposure of the pipe. (The pipe exposed to the outside causes water leak.)

- Wrap heat insulator with its slits facing up (ceiling side).

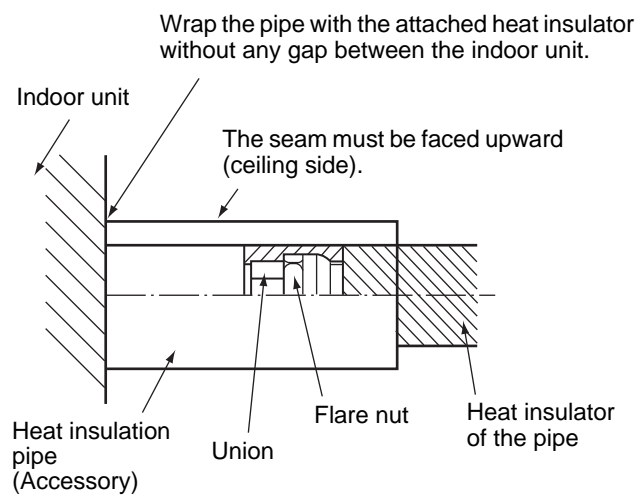

7 ELECTRICAL CONNECTION

WARNING

- Using the specified wires, ensure to connect the wires, and fix wires securely so that the external tension to the wires do not affect the connecting part of the terminals.**
Incomplete connection or fixation may cause a fire, etc.
- Be sure to connect ground wire. (grounding work)**
Incomplete grounding cause an electric shock.
Do not connect ground wires to gas pipes, water pipes, lightning rods or ground wires for telephone wires.
- Appliance shall be installed in accordance with national wiring regulations.**
Capacity shortage of circuit breaker or incomplete installation may cause an electric shock or a fire.

CAUTION

- Consult local building codes, NEC (National Electrical Code) or CEC (Canadian Electrical Code) for special requirements.
- This indoor unit has no power cord.
- If incorrect/incomplete wiring is carried out, it will cause an electrical fire or smoke.
- Be sure to install circuit breaker is not tripped by shock waves.
If circuit breaker is not installed, an electric shock may be caused.
- Be sure to use the cord clamps attached to the product.
- Do not damage or scratch the conductive core and inner insulator of power and system interconnection wires when peeling them.
- Use the power cord and system interconnection wire of specified thickness, type, and protective devices required.

REQUIREMENT

- For power supply wiring, strictly conform to the Local Regulation in each country.
- For wiring of power supply of the outdoor units, follow the Installation Manual of each outdoor unit.
- Never connect 208/230 V power to the terminal blocks (A, B etc.) for control wiring.
(Otherwise, the system will fail.)
- Perform the electric wiring so that it does not come to contact with the high-temperature part of the pipe.
The coating may melt resulting in an accident.
- Run the refrigerant piping line and control wiring line in the same line.
- Do not turn on the circuit breaker of the indoor unit until vacuuming of the refrigerant pipes completes.

Remote control wiring

- For single system, use 2 x AWG20 non polarity wire is used for the remote control wiring.

Wiring

- Connect the connecting wire to the terminal as identified with their respective numbers on the terminal block of indoor and outdoor unit.
(4 x AWG12)
- Insulate the unsheathed redundant cords (conductors) with electrical insulation tape.
Process them so that they do not touch any electrical or metal parts.
- For inter-unit wiring, do not use a wire jointed to another on the way.

	Wire Quantity x size
Indoor unit - Outdoor unit *1	3 x AWG12 (polar)
Ground	1 x AWG12 or thicker
Remote control	2 x AWG20 (non-polar)

*1 :Length of the system interconnection wires.

RAV-	SP180AT2	SP240AT2	SP300AT2 - SP420AT2
Wire length	164'1" (50 m) or less	229'8" (70 m) or less	246'1" (75 m) or less

CAUTION

Use the same size wire for the field power supply wire and system interconnection wires when the outdoor unit is RAV-SP180AT2.

NOTE

- Use copper supply wires.
- Use UL wires rated 600 V for the system interconnection wires.
- Use UL wires rated 300 V for the remote control wires.

■ Wire connection

REQUIREMENT

- Be sure to connect the wires matching the terminal numbers. Incorrect connection causes a trouble.
 - The low-voltage circuit is provided for the remote control. (Do not connect the high-voltage circuit)
-
- Remove the cover of the electric parts box by taking off the mounting screws (2 positions) and pushing the hooking section. (The cover of the electric parts box remains hanged to the hinge.)
 - Remove the 2 screws from the wire cover.
 - Attach the conduit pipe to the conduit plate with a lock nut.
 - Connect the system interconnection wires and remote control wire to the terminal block of the electric parts box. Secure the ground wire with the ground screw.
 - Tighten the screws of the terminal block, and fix the wires with cord clamp attached to the electric parts box. (Do not apply tension to the connecting section of the terminal block.)
 - Mount the wire cover without catching the wires. (The wire cover should be mounted before the ceiling panel.)
 - Mount the cover of the electric parts box without catching the wires. (Mount the cover after wiring on the ceiling panel.)

▼ Thermal insulation to wiring connecting port

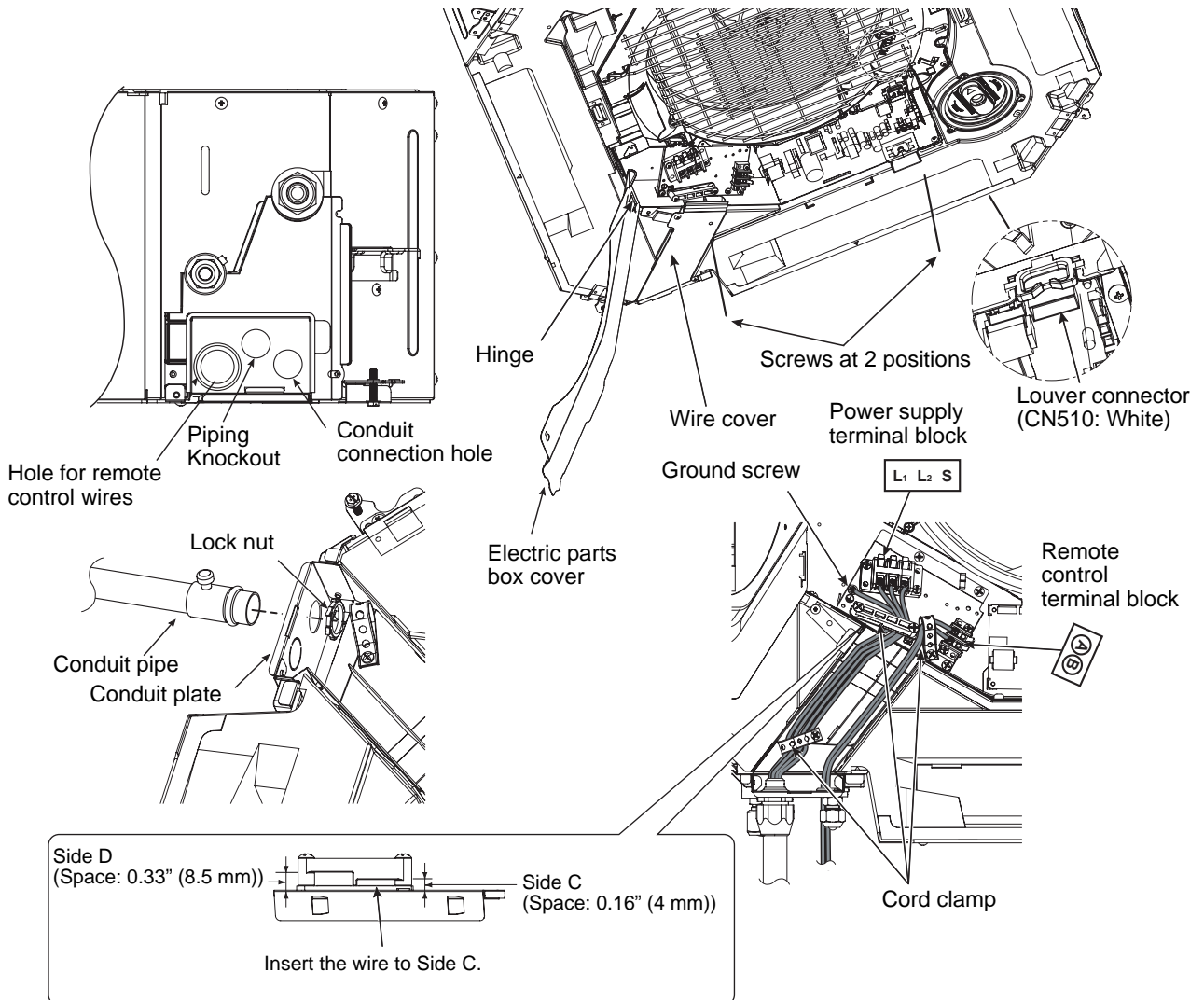

■ System interconnection wires and ground wire

- Strip the wire ends.
System interconnection wire : 0.4" (10 mm)
Ground wire : 0.8" (20 mm)
- Match the wire colors with the terminal numbers on the indoor and outdoor units' terminal blocks and firmly screw the wires to the corresponding terminals.
- Secure the ground wire with the ground screw.
- Fix the wires with a cord clamp.

Unit: in (mm)

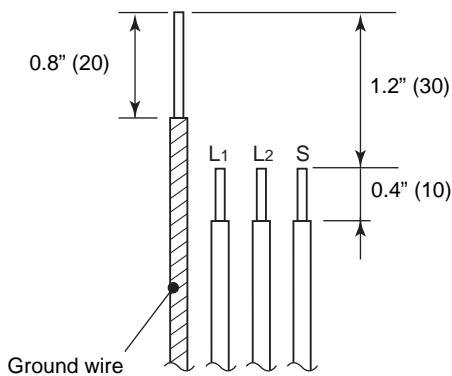

⚠ CAUTION

- Firmly tighten the screws of the terminal block.

Keep the wire length as shown in figure below when it is connected to the terminal block.

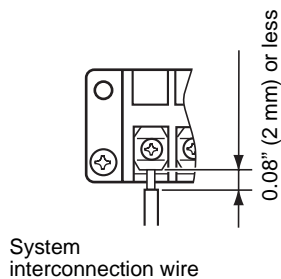

■ Wiring on the ceiling panel

According to the Installation Manual of the ceiling panel, connect the connector (20P: White) of the ceiling panel to the connector (CN510: White) on P.C. board of the electric parts box.

■ Remote Control Wiring

- Strip off the wire approx. 0.4" (9 mm) to connect.
- For a single system, use non polarity, 2 core wire for the remote control wiring. (2 x AWG 20)

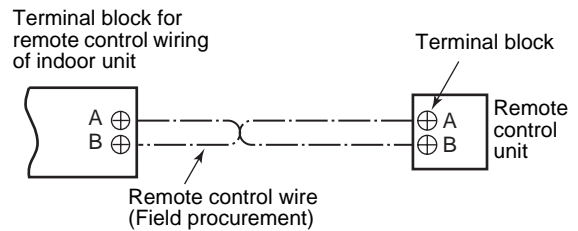

- For the details of wiring/installation of the remote control, refer to the Installation Manual enclosed with the remote control.

■ Wiring diagram

▼ Single system

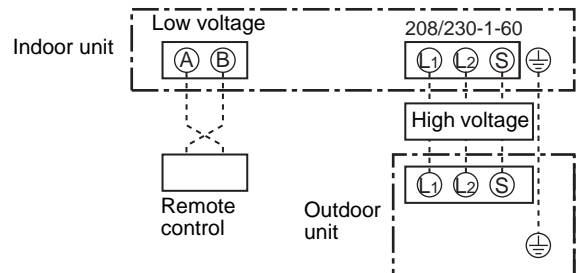

8 APPLICABLE CONTROLS

REQUIREMENT

- When you use this air conditioner for the first time, it takes approx. 5 minutes until the remote control becomes available after power-on. This is normal. **<When power is turned on for the first time after installation>** It takes **approx. 5 minutes** until the remote control becomes available.

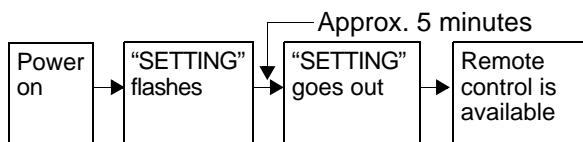

<When power is turned on for the second (or later) time>

It takes **approx. 1 minute** until the remote control becomes available.

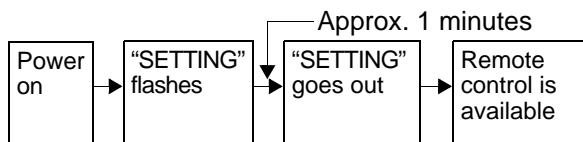

- Normal settings were made as factory default. Change the indoor unit settings as required.
- Use the wired remote control to change the settings.
- * The settings cannot be changed using the wireless remote control, sub remote control, or remote-controlless system (for central remote control only). Therefore, install the wired remote control to change the settings.

Changing applicable control setting

Basic procedure for changing settings

Change the settings while the air conditioner is not working. (Be sure to stop the air conditioner before making settings.)

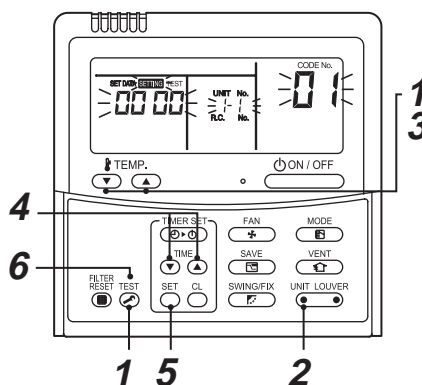

Procedure 1

- Push **TEST** button and temp. setup button simultaneously for at least 4 seconds. After a while, the display flashes as shown in the figure. Confirm that the CODE No. is [01].
- If the CODE No. is not [01], push **TEST** button to erase the display content, and repeat the procedure from the beginning. (No operation of the remote control is accepted for a while after **TEST** button is pushed.)

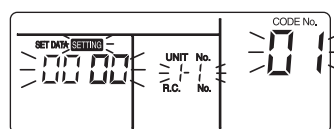

(* Display content varies with the indoor unit model.)

Procedure 2

Each time you push **UNIT LOUVER** button, indoor unit numbers in the control group change cyclically. Select the indoor unit you want to change settings for. The fan of the selected unit runs and the louvers start swinging. You can confirm the indoor unit for which you want to change settings.

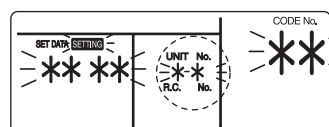

Procedure 3



Using temp. setup (▼) / (▲) buttons, specify CODE No. [**].

Procedure 4

Using timer time (▼) / (▲) buttons, select SET DATA [****].

Procedure 5

Push  button. When the display changes from flashing to lit, the setup is completed.

- To change settings of another indoor unit, repeat from Procedure 2.
 - To change other settings of the selected indoor unit, repeat from Procedure 3.
- Use  button to clear the settings.
To make settings after  button was pushed, repeat from Procedure 2.

Procedure 6

When settings have been completed, push  button to determine the settings.

When  button is pushed, "SETTING" flashes and then the display content disappears and the air conditioner enters the normal stop mode.

(While "SETTING" is flashing, no operation of the remote control is accepted.)

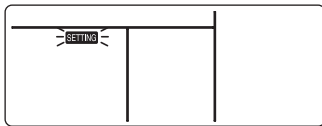

■ Installing indoor unit on high ceiling

When an indoor unit is installed on a ceiling higher than the standard height, make the high-ceiling setting for fan speed adjustment.

Follow to the basic operation procedure

(1 → 2 → 3 → 4 → 5 → 6).

- For the CODE No. in Procedure 3, specify [5d].
- Select the setting data for Procedure 4 from the "Height list of ceiling possible to be installed" table on page 7 in this manual.

■ Using wireless remote control

Change the high-ceiling settings with the DIP switch on the receiver section P.C. board.

For details, refer to the manual of the wireless remote controller kit. The settings can also be changed with the switch on the indoor microcomputer P.C. board.

- * However, once the setting is changed, setting to 0001 or 0003 is possible but setting to 0000 requires a setting data change to 0000 using the wired remote control (sold separately) with the normal switch setting (factory default).

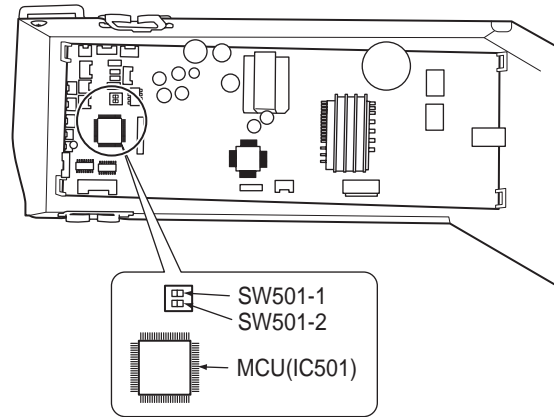

Setup data	SW501-1	SW501-2
0000 (Factory default)	OFF	OFF
0001	ON	OFF
0003	OFF	ON

Restore the factory default

To return the DIP switch settings to the factory default, set SW501-1 and SW501-2 to OFF, connect a separately sold wired remote control, and then set the data of CODE No. [5d] to "0000".

■ Filter sign setting

According to the installation condition, the lighting time of the filter sign (Notification of filter cleaning) can be changed.

Follow to the basic operation procedure (1 → 2 → 3 → 4 → 5 → 6).

- For the CODE No. in Procedure 3, specify [01].
- For the [Set data] in Procedure 4, select the setup data of filter sign lighting time from the following table.

Setup data	Filter sign lighting time
0000	None
0001	150 H
0002	2500 H (Factory default)
0003	5000 H
0004	10000 H

■ To secure better effect of heating

When it is difficult to obtain satisfactory heating due to installation place of the indoor unit or structure of the room, the detection temperature of heating can be raised. Also use a circulator, etc. to circulate heat air near the ceiling.

Follow to the basic operation procedure (1 → 2 → 3 → 4 → 5 → 6).

- For the CODE No. in Procedure 3, specify [06].
- For the set data in Procedure 4, select the setup data of shift value of detection temperature to be set up from the table below.

Setup data	Detection temp shift value
0000	No shift
0001	+1.8 °F (+1 °C)
0002	+3.6 °F (+2 °C) (Factory default)
0003	+5.4 °F (+3 °C)
0004	+7.2 °F (+4 °C)
0005	+9.0 °F (+5 °C)
0006	+10.8 °F (+6 °C)

■ Horizontal louver direction

1. Push **TEST** and **TEMP.** (▼) buttons for at least four seconds when the air conditioner is not working. **SETTING** flashes. Indicates CODE No. "01."
2. Select an indoor unit to be set by pushing **UNIT LOUVER** button (left side of the button). Indoor unit number changes each time you push the button.

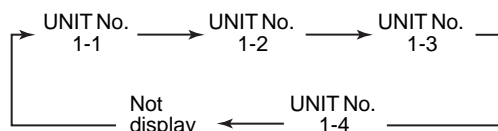

The fan of the selected unit runs and the louvers start swinging.

3. Change the CODE No. to "45" with **TEMP.** (▼) (▲) buttons.
4. Select louver direction setting with **TIME** (▼) (▲) buttons.

Louver direction setting code	Louver direction setting
0000	Smudge reducing position (Air direction to reduce ceiling contamination) [Factory default]
0002	Cold draft position (Air direction to control cold air fall)

5. Push **SET** button to check the setting. The display state changes from flashing to lighting, and the setting is fixed.
6. Push **TEST** button to end the setting.
 - * When the cold draft position is selected, ceiling contamination is less reduced.

■ Swing mode



1. Push  for at least four seconds when the air conditioner is not working.

SETTING flashes.
Indicates CODE No. "F0."

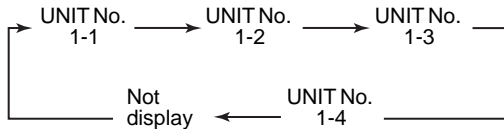
2. Select an indoor unit to be set by pushing  (left side of the button).
Each time you push the button, unit numbers change as follows:



The fan of the selected unit runs and the louvers start swinging.

3. Select a swing mode by pushing TIME   buttons.

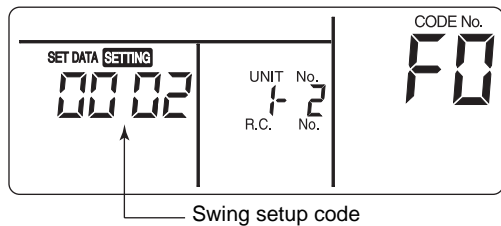

Swing setup code	Swing of louvers
0001	Standard swing (Factory default)
0002	Dual swing
0003	Cycle swing

CAUTION

Do not set the swing setup code to "0000".
(This setting may cause a failure of the louvers.)

• About "Dual swing"

"Dual" means that louvers **01** and **03** are directed and swing in one direction and louvers **02** and **04** are directed and swing in the opposite direction.
(When louvers **01** and **03** are directed downward, louvers **02** and **04** are directed upward.)

• About "Cycle swing"

The four louvers swing independently at respective timings.

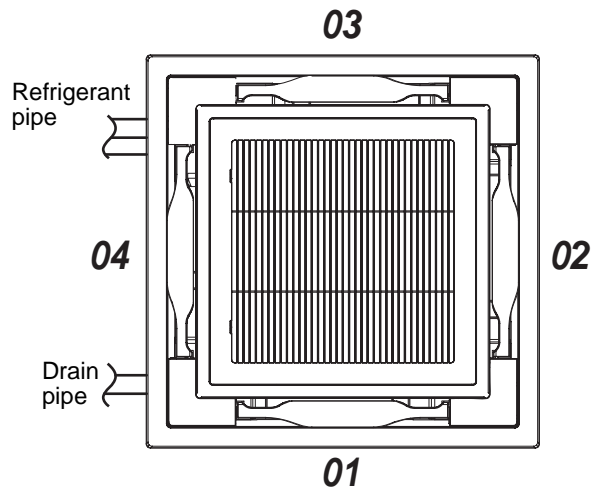

4. Push  button.

5. Push  button to complete the setting.

■ Louver lock (No swing)

1. Push (right side of the button) for at least four seconds when the air conditioner is not working.
SETTING flashes.

Indicates CODE No. "F1."

2. Select an indoor unit to be set by pushing (left side of the button).

Each time you push the button, unit numbers change as follows:

The fan of the selected unit runs and the louvers start swinging.

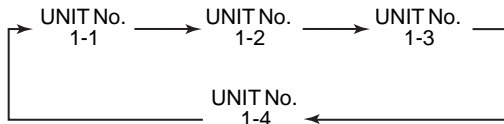

3. Select a louver you want to lock by pushing TEMP. buttons.

4. Select the louver direction you do not want to swing by pushing TIME buttons.

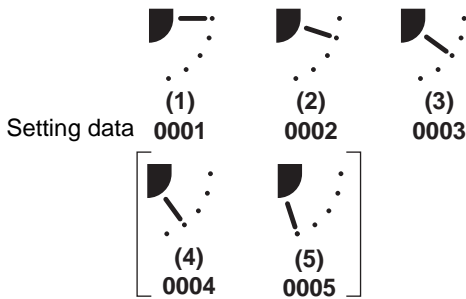

* When (4) or (5) is selected, dew drop may occur during cooling mode.

5. Determine the setting by pushing button.
 When the setting has been determined, lights up.

6. Push button to complete the setting.

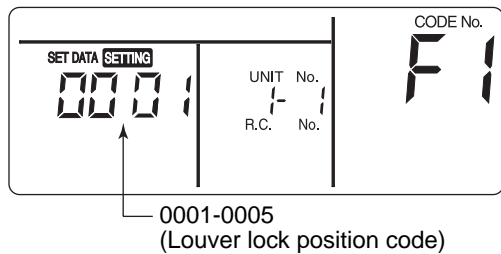

■ Cancel louver lock

Set the louver direction to "0000" of the louver lock setup procedure above.



Setting data 0000

- When the setting is canceled, goes out. **Other operations are the same as those in "Louver lock (No swing)".**

■ Power saving mode

1. Push button for at least four seconds when the air conditioner is not working.

SETTING flashes.

Indicates CODE No. "C2."

2. Select an indoor unit to be set by pushing (left side of the button).

Each time you push the button, unit numbers change as follows:



The fan of the selected unit runs and the louvers start swinging.

3. Adjust the power save setting by pushing TIME buttons.

Each push of the button changes the power level by 1% within the range from 100% to 50%.

* The factory default is 75%.

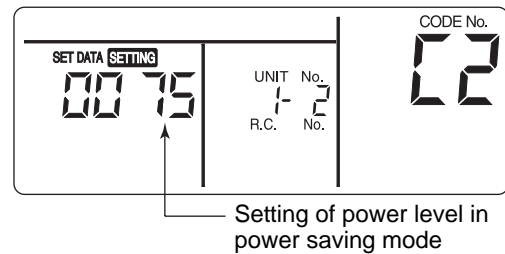

- Determine the setting by pushing button.
- Push button to complete the setting.

Remote control switch monitoring function

This function is available to call the service monitor mode from the remote control during a test run to acquire temperatures of sensors of the remote control, indoor unit, and outdoor unit.

1. Push **CL** and **TEST** buttons simultaneously for at least 4 seconds to call the service monitor mode. The service monitor indicator lights up and the header indoor unit number is displayed first. CODE No. **00** is also displayed.
2. Pushing **TEMP.** (▼) (▲) buttons, select the number of sensor, etc. (CODE No.) to be monitored. (See the following table.)
3. Pushing **UNIT LOUVER** (left side of the button), select an indoor unit to be monitored. The sensor temperatures of indoor units and their outdoor unit in the control group are displayed.
4. Push **TEST** button to return to the normal display.

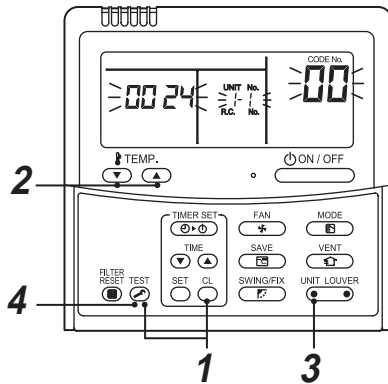

Outdoor unit data	
CODE No.	Data name
60	Outdoor unit heat exchanger temperature (TE)
61	Outside air temperature (TO)
62	Compressor discharge air temperature (TD)
63	Compressor intake air temperature (TS)
64	—
65	Heatsink temperature (THS)
6A	Operating current (x1/10)
F1	Compressor cumulative operating hours (x100h)

Indoor unit data	
CODE No.	Data name
01	Room temperature (remote control)
02	Indoor unit intake air temperature (TA)
03	Indoor unit heat exchanger temperature (TCJ)
04	Indoor unit heat exchanger temperature (TC)
F3	Indoor unit fan cumulative operating hours (x1 h)
F8	Indoor unit discharge air temperature

Group control for system of multiple units

One remote control can control maximum 8 indoor units as a group.

▼ Group control in single system

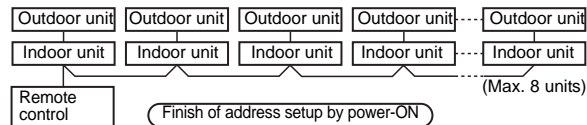

- For wiring procedure and wiring method of the individual line (Identical refrigerant line) system, follow to “Electric work”.
- Wiring between lines is performed in the following procedure. Connect the terminal block (A/B) of the indoor unit connected with a remote control to the terminal blocks (A/B) of the indoor units of other indoor units by wiring the inter-unit wire of the remote control.
- When the circuit breaker is turned on, the automatic address setup starts and which indicates that address is being set up flashes on the display part. During setup of automatic address, the remote control operation is not accepted.

Required time up to the finish of automatic addressing is approx. 5 minutes.

NOTE

In some cases, it is necessary to change the address manually after setup of the automatic address according to the system configuration of the group control.

- The above mentioned system configuration is a case when complex systems in which systems of the multiple twin unit is controlled as a group by a remote control.

Procedure example 1

Manual address setup procedure

While the operation stops, change the setup. (Be sure to stop the operation of the unit.)

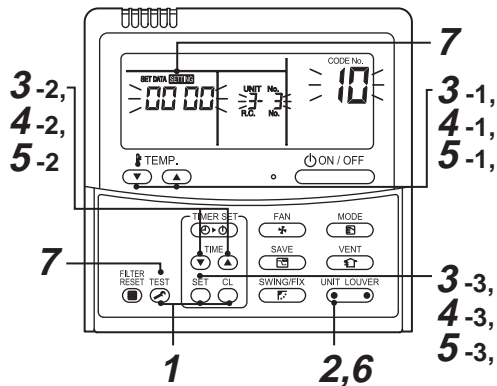

Procedure 1

Push simultaneously **SET** + **CL** + **TEST** buttons for 4 seconds or more. After a while, the display part flashes as shown below. Check the displayed CODE No. is [10].

- When the CODE No. is other than [10], push **TEST** button to erase the display and repeat procedure from the first step. (After pushing **TEST** button, operation of the remote control is not accepted for approx. 1 minute.) (For a group control, No. of the firstly displayed indoor unit becomes the header unit.)

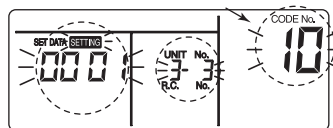

(* Display changes according to the model No. of indoor unit.)

Procedure 2

Every pushing **UNIT LOUVER** button, the indoor UNIT No. in the group control is displayed in order. Select the indoor unit of which setup is changed.

In this time, the position of the indoor unit of which setup is changed can be confirmed because fan and louver of the selected indoor unit operate.

Procedure 3

- Using temp. setup ∇ / \blacktriangle buttons, specify CODE No. [12].
(CODE No. [12]: Line address)
- Using timer time ∇ / \blacktriangle buttons, change the line address from [3] to [2].
- Push SET button.
In this time, the setup finishes when the display changes from flashing to lighting.

Indoor UNIT No. before setup change is displayed.

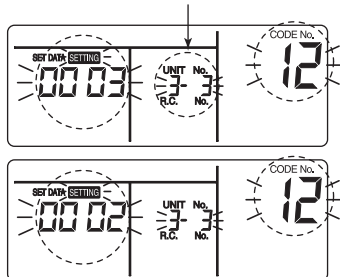

Procedure 4

- Using temp. setup ∇ / \blacktriangle buttons, specify CODE No. [13].
(CODE No. [13]: Indoor address)
- Using timer time ∇ / \blacktriangle buttons, change the indoor address from [3] to [2].
- Push SET button.
In this time, the setup finishes when the display changes from flashing to lighting.

Indoor UNIT No. before setup change is displayed.

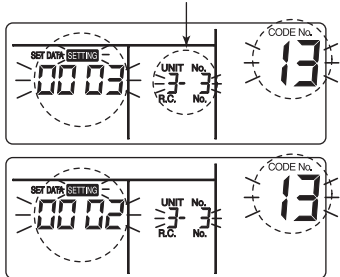

Procedure 5

- Using temp. setup ∇ / \blacktriangle buttons, specify CODE No. [14].
(CODE No. [14]: Group address)
- Using timer time ∇ / \blacktriangle buttons, change the setup data from [0001] to [0002].
(Setup data [Header unit: 0001] [Follower unit: 0002])
- Push SET button.
In this time, the setup finishes when the display changes from flashing to lighting.

Indoor UNIT No. before setup change is displayed.

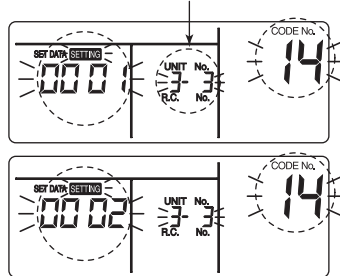

Procedure 6

If there is other indoor unit to be changed, repeat procedure 2 to 5 to change the setup. When the above setup has finished, push UNIT LOUVER to select the indoor UNIT No. before change of setup, specify CODE No. [12], [13], [14] in order with temp. setup ∇ / \blacktriangle buttons, and then check the changed contents.

Address change check Before change: [3-3-1] → After change: [2-2-2]

Pushing CL button clears the contents of which setup was changed. (In this case, procedure from 2 is repeated.)

Indoor UNIT No. before setup change is displayed.

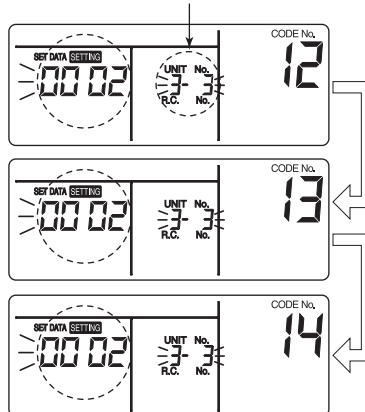

Procedure 7

After check of the changed contents, push **TEST** button. (Setup is determined.) When pushing **TEST** button, the display disappears and the status becomes the usual stop status. (When pushing **TEST** button the operation from the remote control is not accepted for approx. 1 minute.)

- * If the operation from the remote control is not accepted even 1 minute or more passed after pushing **TEST** button, it is considered that the address setup is incorrect. In this case, the automatic address must be again set up. Therefore repeat procedure of the setup change from the Procedure 1.

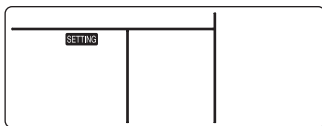

To recognize the position of the corresponding indoor unit though the indoor UNIT No. is known

Check the position during operation stop. (Be sure to stop operation of the set.)

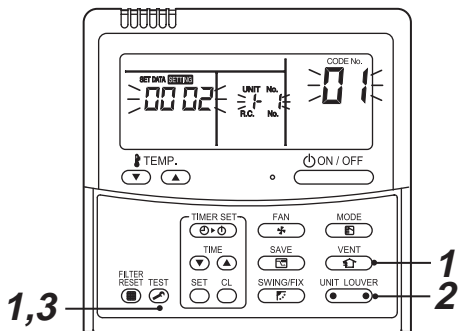

Procedure 1

Push simultaneously **TEST** + **VENT** buttons for 4 seconds or more.

After a while, the display part flashes and the display appears as shown below.

In this time, the position can be checked because fan and louver of the indoor unit operate.

- For the group control, the indoor UNIT No. is displayed as [ALL] and fans and louvers of all the indoor units in the group control operate.

Check the displayed CODE No. is [01].

- When the CODE No. is other than [01], push **TEST** button to erase the display and repeat procedure from the first step.

(After pushing **TEST** button, operation of the remote control is not accepted for approx. 1 minute.)

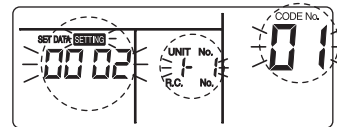

(* Display changes according to the model No. of indoor unit.)

Procedure 2

In the group control, every pushing **UNIT LOUVER** button, the indoor UNIT No. in the group control is displayed in order.

In this time, the position of the indoor unit can be confirmed because only fan and louver of the selected indoor unit operate.

(For a group control, No. of the firstly displayed indoor unit becomes the header unit.)

Procedure 3

After confirmation, push **TEST** button to return the mode to the usual mode.

When pushing **TEST** button, the display disappears and the status becomes the usual stop status.

(When pushing **TEST** button the operation from the remote control is not accepted for approx. 1 minute.)

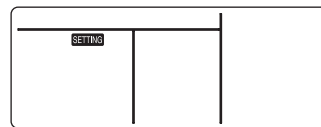

9 TEST RUN

Before test run

- Before turning on the circuit breaker, carry out the following procedure.
 - 1) Using 500V-megger, check that resistance of 1MΩ or more exists between the terminal block L1 to L2 and the ground (grounding).
If resistance of less than 1MΩ is detected, do not run the unit.
 - 2) Check the valve of the outdoor unit being opened fully.
- To protect the compressor at activation time, leave power-ON for 12 hours or more before operating.

Execute a test run

Using the remote control, operate the unit as usual. For the procedure of the operation, refer to the attached Owner's Manual.

A forced test run can be executed in the following procedure even if the operation stops by thermo.-OFF. In order to prevent a serial operation, the forced test run is released after 60 minutes have passed and returns to the usual operation.

CAUTION

- Do not use the forced test run for cases other than the test run because it applies an excessive load to the devices.

Wired remote control

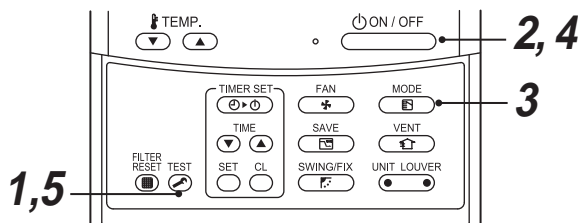

Procedure 1

Keep  button pushed for 4 seconds or more. [TEST] is displayed on the display part and the selection of mode in the test mode is permitted.

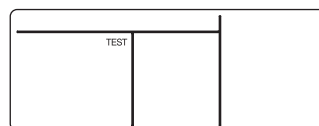

Procedure 2

Push  button.

Procedure 3

Using  button, select the operation mode, [COOL] or [HEAT].

- Do not run the air conditioner in a mode other than [COOL] or [HEAT].
- The temperature controlling function does not work during test run.
- The detection of error is performed as usual.

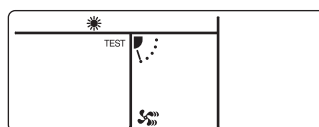

Procedure 4

After the test run, push  button to stop a test run.

(Display part is same as procedure 1.)

Procedure 5

Push  check button to cancel (release from) the test run mode.

([TEST] disappears on the display and the status returns to a normal.)

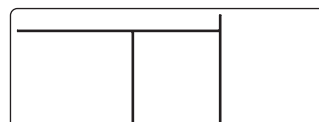

Wireless remote control

Procedure 1

Turn on the power of the air conditioner.
When power is turned on for the first time after installation, it takes approx. 5 minutes until the remote control becomes available. In the case of subsequent power-on, it takes approx. 1 minute until the remote control becomes available. Execute a test run after the predetermined time has passed.

Procedure 2

Push "ON/OFF" button on the remote control, select [COOL] or [HEAT] with "MODE" button, and then select [HIGH] with "FAN" button.

Procedure 3

Cooling test run	Heating test run
Set the temperature to 64 °F (18°C) with the temp. setup buttons.	Set the temperature to 86 °F (30°C) with the temp. setup buttons.

Procedure 4

Cooling test run	Heating test run
After confirming a signal receiving sound "beep" immediately set the temperature to 66 °F (19°C) with the temp. setup buttons.	After confirming a signal receiving sound "beep" immediately set the temperature to 84 °F (29°C) with the temp. setup buttons.

Procedure 5

Cooling test run	Heating test run
After confirming a signal receiving sound "beep" immediately set the temperature to 64 °F (18°C) with the temp. setup buttons.	After confirming a signal receiving sound "beep" immediately set the temperature to 86 °F (30°C) with the temp. setup buttons.

Procedure 6

Repeat procedures **4** → **5** → **4** → **5**.
Indicators "Operation" (green), "Timer" (green), and "Ready" (orange) in the wireless receiver section flash in approx. 10 seconds, and the air conditioner starts operation. If any of these indicators does not flash, repeat procedures **2** to **5**.

Procedure 7

Upon completion of the test run, push "ON/OFF" button to stop operation.

<Overview of test run operations using the wireless remote control>

▼ Cooling test run:

ON/OFF → 64 °F (18 °C) → 66 °F (19 °C) → 64 °F (18 °C) → 66 °F (19 °C) → 64 °F (18 °C) → 66 °F (19 °C) → 64 °F (18 °C) → (test run) → ON/OFF

▼ Heating test run:

ON/OFF → 86 °F (30 °C) → 84 °F (29 °C) → 86 °F (30 °C) → 84 °F (29 °C) → 86 °F (30 °C) → 84 °F (29 °C) → 86 °F (30 °C) → (test run) → ON/OFF

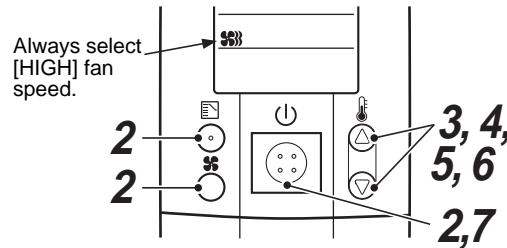

10 TROUBLESHOOTING

Confirmation and check

When a trouble occurred in the air conditioner, the check code and the indoor UNIT No. appear on the display part of the remote control.

The check code is only displayed during the operation. If the display disappears, operate the air conditioner according to the following "Confirmation of error history" for confirmation.

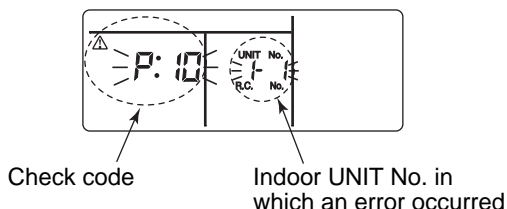

Confirmation of error history

When a trouble occurred on the air conditioner, the trouble history can be confirmed with the following procedure. (The trouble history is stored in memory up to 4 troubles.)

The history can be confirmed from both operating status and stop status.

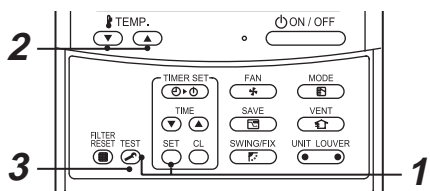

Procedure 1

When pushing SET and TEST buttons at the same time for 4 seconds or more, the following display appears.

If [Service check] is displayed, the mode enters in the trouble history mode.

- [01 : Order of trouble history] is displayed in CODE No. window.
- [Check code] is displayed in CHECK window.
- [Indoor unit address in which an error occurred] is displayed in Unit No.

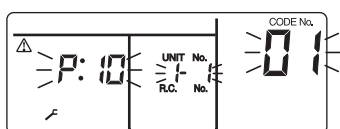

Procedure 2

Every pushing of TEMP. button used to set temperature, the trouble history stored in memory is displayed in order.

The numbers in CODE No. indicate CODE No. [01] (latest) → [04] (oldest).

REQUIREMENT

Do not push CL button because all the trouble history of the indoor unit will be deleted.

Procedure 3

After confirmation, push TEST button to return to the usual display.

1. Check the troubles according to the above procedure.
2. Ask an authorized dealer or qualified service (maintenance) professional to repair or maintain the air conditioner.

■ Check codes and parts to be checked

Wired remote control display	Wireless remote control Sensor block display of receiving unit				Main defective parts	Judging device	Parts to be checked / error description	Air conditioner status
	Indication	Operation GR	Timer GR	Ready OR				
E01	○ ● ●				No header remote control	Remote control	Incorrect remote control setting --- The header remote control has not been set (including two remote controls).	*
					Remote control communication error		No signal can be received from the indoor unit.	
E02	○ ● ●				Remote control transmission error	Remote control	System interconnection wires, indoor P.C. board, remote control --- No signal can be sent to the indoor unit.	*
E03	○ ● ●				Indoor unit-remote control regular communication error	Indoor	Remote control, network adapter, indoor P.C. board --- No data is received from the remote control or network adapter.	Auto-reset
E04	● ● ○				Indoor unit-outdoor unit serial communication error	Indoor	System interconnection wires, indoor P.C. board, outdoor P.C. board --- Serial communication error between indoor unit and outdoor unit	Auto-reset
					IPDU-CDB communication error			
E08	○ ● ●				Duplicated indoor addresses ★	Indoor	Indoor address setting error --- The same address as the self-address was detected.	Auto-reset
E09	○ ● ●				Duplicated header remote controls	Remote control	Remote control address setting error --- Two remote controls are set as header in the double-remote control control.	*
							(* The header indoor unit stops raising alarm and follower indoor units continue to operate.)	
E10	○ ● ●				CPU-CPU communication error	Indoor	Indoor P.C. board --- Communication error between main MCU and motor microcomputer MCU	Auto-reset
E18	○ ● ●				Header indoor unit-indoor follower unit regular communication error	Indoor	Indoor P.C. board --- Regular communication is not possible between header and follower indoor units or between twin header (main) and follower (sub) units.	Auto-reset
E31	● ● ○				IPDU communication error	Outdoor	Communication error between IPDU and CDB	Entire stop
F01	○ ○ ●			ALT	Indoor unit heat exchanger sensor (TCJ) error	Indoor	Heat exchanger sensor (TCJ), indoor P.C. board --- Open-circuit or short-circuit of the heat exchanger sensor (TCJ) was detected.	Auto-reset
F02	○ ○ ●			ALT	Indoor unit heat exchanger sensor (TC) error	Indoor	Heat exchanger sensor (TC), indoor P.C. board --- Open-circuit or short-circuit of the heat exchanger sensor (TC) was detected.	Auto-reset
F04	○ ○ ○			ALT	Outdoor unit discharge temp. sensor (TD) error	Outdoor	Outdoor temp. sensor (TD), outdoor P.C. board --- Open-circuit or short-circuit of the discharge temp. sensor was detected.	Entire stop
F06	○ ○ ○			ALT	Outdoor unit temp. sensor (TE/TS) error	Outdoor	Outdoor temp. sensors (TE/TS), outdoor P.C. board --- Open-circuit or short-circuit of the heat exchanger temp. sensor was detected.	Entire stop
F07 (F06)	○ ○ ○			ALT	TL sensor error	Outdoor	TL sensor may be displaced, disconnected or short-circuited.	Entire stop
F08	○ ○ ○			ALT	Outdoor unit outside air temp. sensor error	Outdoor	Outdoor temp. sensor (TO), outdoor P.C. board --- Open-circuit or short-circuit of the outdoor air temp. sensor was detected.	Operation continued
F10	○ ○ ●			ALT	Indoor unit room temp. sensor (TA) error	Indoor	Room temp. sensor (TA), indoor P.C. board --- Open-circuit or short-circuit of the room temp. sensor (TA) was detected.	Auto-reset
F12 (F06)	○ ○ ○			ALT	TS sensor error	Outdoor	TS sensor may be displaced, disconnected or short-circuited.	Entire stop
F13 (L29)	○ ○ ○			ALT	Heat sink sensor error	Outdoor	Abnormal temperature was detected by the temp. sensor of the IGBT heat sink.	Entire stop
F15 (F06)	○ ○ ○			ALT	Temp. sensor connection error	Outdoor	Temp. sensor (TE/TS) may be connected incorrectly.	Entire stop
F29	○ ○ ●			SIM	Indoor unit, other P.C. board error	Indoor	Indoor P.C. board --- EEPROM error	Auto-reset

F31 (L29)	⊙ ⊙ ○	SIM	Outdoor unit P.C. board	Outdoor	Outdoor P.C. board ---- In the case of EEPROM error.	Entire stop
H01	● ⊙ ●		Outdoor unit compressor breakdown	Outdoor	Current detect circuit, power voltage --- Minimum frequency was reached in the current releasing control or short-circuit current (I _{dc}) after direct excitation was detected Wiring error of compressor (open phase)	Entire stop
H02	● ⊙ ●		Outdoor unit compressor lock	Outdoor	Compressor circuit --- Compressor lock was detected. Wiring error of compressor (open phase)	Entire stop
H03	● ⊙ ●		Outdoor unit current detect circuit error	Outdoor	Current detect circuit, outdoor unit P.C. board --- Abnormal current was detected in AC-CT or a phase loss was detected.	Entire stop
H04 (P04)	● ⊙ ●		Case thermostat operation	Outdoor	Malfunction of the case thermostat	Entire stop
H06	● ⊙ ●		Outdoor unit low-pressure system error	Outdoor	Current, high-pressure switch circuit, outdoor P.C. board --- Ps pressure sensor error was detected or low-pressure protective operation was activated.	Entire stop
L03	⊙ ● ⊙	SIM	Duplicated header indoor units ★	Indoor	Indoor address setting error --- There are two or more header units in the group.	Entire stop
L07	⊙ ● ⊙	SIM	Group line in individual indoor unit ★	Indoor	Indoor address setting error --- There is at least one group-connected indoor unit among individual indoor units.	Entire stop
L08	⊙ ● ⊙	SIM	Indoor group address not set ★	Indoor	Indoor address setting error --- Indoor address group has not been set.	Entire stop
L09	⊙ ● ⊙	SIM	Indoor power level not set	Indoor	Indoor power level has not been set.	Entire stop
L10 (L29)	⊙ ○ ⊙	SIM	Outdoor unit P.C. board	Outdoor	In the case of outdoor P.C. board jumper wire (for service) setting error	Entire stop
L20	⊙ ○ ⊙	SIM	LAN communication error	Network adapter central control	Address setting, central control remote control, network adapter --- Duplication of address in central control communication	Auto-reset
L29	⊙ ○ ⊙	SIM	Other outdoor unit error	Outdoor	Other outdoor unit error	Entire stop
					1) Communication error between IPDU MCU and CDB MCU	Entire stop
					2) Abnormal temperature was detected by the heat sink temp. sensor in IGBT.	
L30	⊙ ○ ⊙	SIM	Abnormal external input into indoor unit (interlock)	Indoor	External devices, outdoor unit P.C. board --- Abnormal stop due to incorrect external input into CN80	Entire stop
L31	⊙ ○ ⊙	SIM	Phase sequence error, etc.	Outdoor	Power supply phase sequence, outdoor unit P.C. board -- Abnormal phase sequence of the 3-phase power supply	Operation continued (thermostat OFF)
P01	● ⊙ ⊙	ALT	Indoor unit fan error	Indoor	Indoor fan motor, indoor P.C. board --- Indoor AC fan error (fan motor thermal relay activated) was detected.	Entire stop
P03	⊙ ● ⊙	ALT	Outdoor unit discharge temp. error	Outdoor	An error was detected in the discharge temp. releasing control.	Entire stop
P04	⊙ ● ⊙	ALT	Outdoor unit high-pressure system error	Outdoor	High-pressure switch --- The IOL was activated or an error was detected in the high-pressure releasing control using the TE.	Entire stop
P05 (P04)	⊙ ● ⊙	ALT	Open phase detected	Outdoor	The power cable may be connected incorrectly. Check open phase and voltages of the power supply.	Entire stop
P07	⊙ ● ⊙	ALT	Heat sink overheat	Outdoor	Abnormal temperature was detected by the temp. sensor of the IGBT heat sink.	Entire stop
P10	● ⊙ ⊙	ALT	Indoor unit water overflow detected	Indoor	Drain pipe, clogging of drainage, float switch circuit, indoor P.C. board --- Drainage is out of order or the float switch was activated.	Entire stop
P15 (L29)	⊙ ● ⊙	ALT	Gas leakage detected	Outdoor	There may be gas leakage from the pipe or connecting part. Check for gas leakage.	Entire stop
P19 (L29)	⊙ ● ⊙	ALT	4-way valve error	Outdoor (Indoor)	4-way valve, indoor temp. sensors (TC/TCJ) --- An error was detected due to temperature drop of the indoor unit heat exchanger sensor when heating.	Auto-reset (Auto-reset)
P20 (P04)	⊙ ● ⊙	ALT	High-pressure protective operation	Outdoor	High-pressure protection	Entire stop

P22	⊙ ● ⊙	ALT	Outdoor unit fan error	Outdoor	Outdoor unit fan motor, outdoor unit P.C. board --- An error (overcurrent, locking, etc.) was detected in the outdoor unit fan drive circuit.	Entire stop
P26	⊙ ● ⊙	ALT	Outdoor unit inverter Idc activated	Outdoor	IGBT, outdoor unit P.C. board, inverter wiring, compressor --- Short-circuit protection for compressor drive circuit devices (G-Tr/IGBT) was activated.	Entire stop
P29	⊙ ● ⊙	ALT	Outdoor unit position error	Outdoor	Outdoor unit P.C. board, high-pressure switch --- Compressor motor position error was detected.	Entire stop
P31	⊙ ● ⊙	ALT	Other indoor unit error	Indoor	Another indoor unit in the group is raising an alarm.	Entire stop
					E03/L07/L03/L08 alarm check locations and error description	Auto-reset

Check codes in parentheses () are displayed when connected to an outdoor unit other than the new SDI series.

○ : Lighting ⊙ : Flashing ● : OFF ★ : The air conditioner automatically enters the auto-address setting mode.

ALT: When two LEDs are flashing, they flash alternately. SIM: When two LEDs are flashing, they flash in synchronization.

Receiving unit display OR: Orange GR: Green

