

# Installation Instructions



**NOTE:** Read the entire instruction manual before starting the installation.

## TABLE OF CONTENTS

	PAGE
PARTS LIST .....	2
MODEL NUMBER NOMENCLATURE .....	2
SAFETY CONSIDERATIONS .....	3
SYSTEM REQUIREMENTS .....	3
DIMENSIONS .....	5
CLEARANCES .....	6
INSTALLATION TIPS .....	7
INDOOR UNIT INSTALLATION .....	7
OUTDOOR UNIT INSTALLATION .....	8
ELECTRICAL DATA .....	9
CONNECTION DIAGRAMS .....	9
REMOTE CONTROL INSTALLATION .....	10
SYSTEM VACUUM AND CHARGE .....	10
START-UP .....	11
TROUBLESHOOTING .....	12

## PARTS LIST

PART #	PART NAME	Qty.
1	Indoor Unit	1
2	Mounting Plate	1
3	Mounting Screw A ST3.9x25-C-H	5
4	Anchor	5
5	Air Filter	1
6	Remote Control	1
7	Remote Control Holder	1
8	Mounting Screw B ST2.0x10-C-H	2
9	Outdoor Unit	1

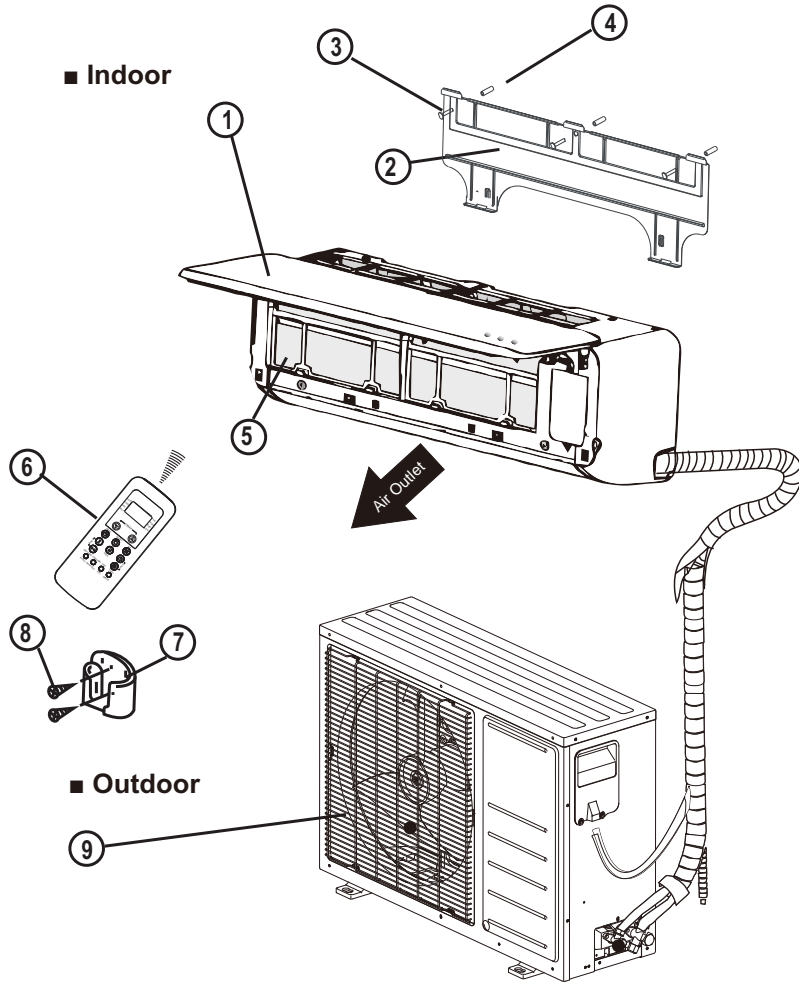

A14342

**Note:**

- If the outdoor unit is higher than the indoor unit, prevent rain from flowing into the indoor unit along the connection pipe by making a downward arc in the connection pipe before it enters the wall to the indoor unit. This will ensure that rain will drip from the connection pipe before it enters the wall.
- Piping and the interconnecting wiring are field supplied.
- The illustration above is only a sketch. Different models may be slightly different.

### MODEL NUMBER NOMENCLATURE

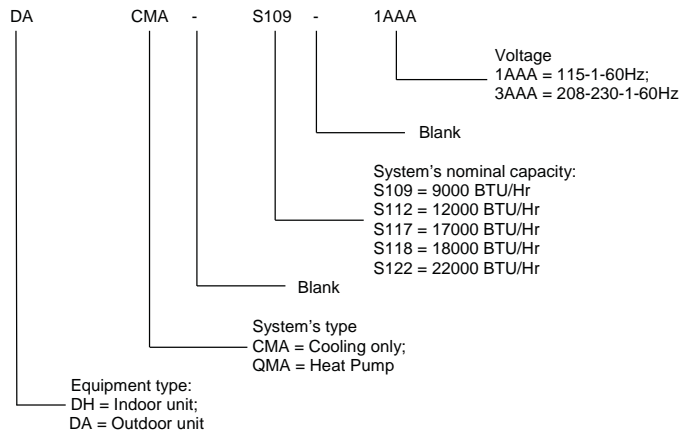

## SAFETY CONSIDERATIONS

Installing, starting up, and servicing air-conditioning equipment can be hazardous due to system pressures, electrical components, and equipment location (roofs, elevated structures, etc.).

Only trained, qualified installers and service mechanics should install, start-up, and service this equipment.

Untrained personnel can perform basic maintenance functions such as cleaning coils. All other operations should be performed by trained service personnel.

When working on the equipment, observe precautions in the literature and on tags, stickers, and labels attached to the equipment.

Follow all safety codes. Wear safety glasses and work gloves. Keep quenching cloth and fire extinguisher nearby when brazing. Use care in handling, rigging, and setting bulky equipment.

Read these instructions thoroughly and follow all warnings or cautions included in literature and attached to the unit. Consult local building codes and National Electrical Code (NEC) for special requirements. Recognize safety information. This is the safety-alert symbol . When you see this symbol on the unit and in instructions or manuals, be alert to the potential for personal injury. Understand these signal words: DANGER, WARNING, and CAUTION. These words are used with the safety-alert symbol. DANGER identifies the most serious hazards which **will** result in severe personal injury or death. WARNING signifies hazards which **could** result in personal injury or death. CAUTION is used to identify unsafe practices which **may** result in minor personal injury or product and property damage. NOTE is used to highlight suggestions which **will** result in enhanced installation, reliability, or operation.



## WARNING

**ELECTRICAL SHOCK HAZARD**

Failure to follow this warning could result in personal injury or death.

Before installing, modifying, or servicing system, main electrical disconnect switch must be in the OFF position. There may be more than 1 disconnect switch. Lock out and tag switch with a suitable warning label.



## WARNING



**EXPLOSION HAZARD**

Failure to follow this warning could result in death, serious personal injury, and/or property damage.

Never use air or gases containing oxygen for leak testing or operating refrigerant compressors. Pressurized mixtures of air or gases containing oxygen can lead to an explosion.



## CAUTION

**EQUIPMENT DAMAGE HAZARD**

Failure to follow this caution may result in equipment damage or improper operation.

Do not bury more than 36 in. (914 mm) of refrigerant pipe in the ground. If any section of pipe is buried, there must be a 6 in. (152 mm) vertical rise to the valve connections on the outdoor units. If more than the recommended length is buried, refrigerant may migrate to the cooler buried section during extended periods of system shutdown. This causes refrigerant slugging and could possibly damage the compressor at start-up.

## SYSTEM REQUIREMENTS

Allow sufficient space for airflow and servicing unit. See Fig. 3 and 4 for minimum required distances between unit and walls or ceilings.

### Piping

**IMPORTANT: Both refrigerant lines must be insulated separately.**

- Minimum refrigerant line length between the indoor and outdoor units is 10 ft. (3 m).
- The following maximum lengths are allowed:

**Table 1—Refrigerant Line Lengths**

Unit Size	Max Line Length	Max Elevation (ID over OD)	Max Elevation (OD over ID)
9K	82 (25)	32 (10)	32 (10)
12K	82 (25)	32 (10)	32 (10)
17K HP	98 (30)	65 (20)	65 (20)
18K AC	98 (30)	65 (20)	65 (20)
22K	131 (40)	65 (20)	65 (20)

- The following are the piping sizes.

**Table 2—Pipe Sizes (in)**

Unit Size	Mix Phase	Vapor
9K	1/4	3/8
12K	1/4	1/2
17K HP	1/4	1/2
18K AC	1/4	1/2
22K	3/8	5/8

### Refrigerant Charge

**Table 3—Refrigerant Charge lb. (kg)**

Unit Size	Air Conditioner (AC)	Heat Pump (HP)
9K	1.34 (0.61)	2.70 (1.18)
12K	1.43 (0.65)	2.70 (1.18)
17K HP	NA	2.87 (1.30)
18K AC	1.87 (0.85)	NA
22K	2.60 (1.18)	3.52 (1.60)

- Above charge is for piping runs up to 25 ft. (7.6 m).
- **For piping runs greater than 25 ft. (7.6 m), add refrigerant up to the allowable length as specified below:**

**Table 4—Additional Refrigerant Charge**

Unit Size	oz./ft. (g/m)
9K – 18K	0.16 (15)
22K	0.32 (30)

- Capillary tubes in outdoor unit are used as metering devices.

## WIRING

All wires must be sized per NEC (National Electrical Code) or CEC (Canadian Electrical Code) and local codes. Use Electrical Data table MCA (minimum circuit amps) and MOCP (maximum over current protection) to correctly size the wires and the disconnect fuse or breakers respectively. Per the caution note, only stranded copper conductors with a 600 volt rating and double insulated copper wire must be used.

The use of BX cable is not recommended.

### **Recommended Connection Method for Power and Communication Wiring – Power and Communication Wiring:**

The main power is supplied to the outdoor unit. The field supplied 14/3 power/communication wiring from the outdoor unit to indoor unit consists of four (4) wires and provides the power for the indoor unit. Two wires are high voltage AC power, one is communication wiring and the other is a ground wire.

### **Recommended Connection Method for Power and Communication Wiring (To minimize communication wiring interference)**

#### **Power Wiring:**

The main power is supplied to the outdoor unit. The field supplied power wiring from the outdoor unit to indoor unit consists of three (3) wires and provides the power for the indoor unit. Two wires are high voltage AC power and one is a ground wire. To minimize voltage drop, the factory recommended wire size is 14/2 stranded with a ground.

#### **Communication Wiring:**

A separate shielded Stranded copper conductor only, with a 600 volt rating and double insulated copper wire, must be used as the communication wire from the outdoor unit to the indoor unit. Please use a separate shielded 16GA stranded control wire.



## CAUTION

### **EQUIPMENT DAMAGE HAZARD**

Failure to follow this caution may result in equipment damage or improper operation.

- Wires should be sized based on NEC and local codes.
- Use copper conductors only with a 600 volt rating and double insulated copper wire.

## DIMENSIONS – INDOOR

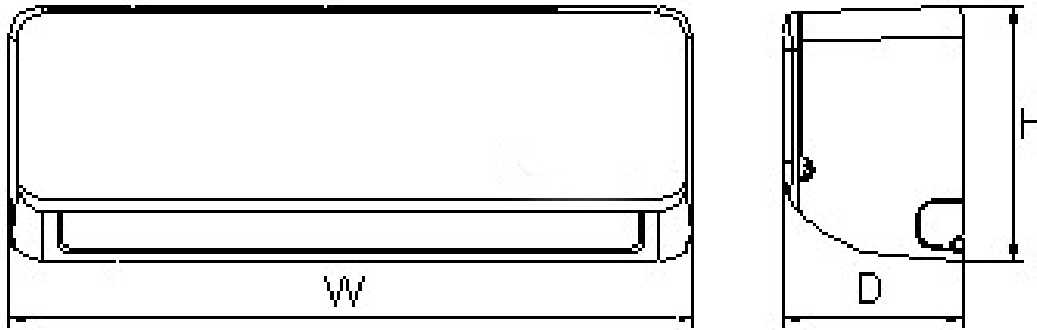

Fig. 1 – Dimensions – Indoor

A14343

Table 5—Dimensions – Indoor

Unit Size	W in (mm)	D in (mm)	H in (mm)	Operating Weight lb (kg)
9K	26.8 (680)	7.0 (178)	10.0 (255)	15.4 (7)
12K	30.3 (770)	7.4 (188)	10.0 (255)	16.5 (7.5)
17K HP / 18K AC	35.6 (905)	7.8 (198)	10.8 (275)	19.8 (9)
22K	40.6 (1030)	8.6 (218)	12.4 (315)	26.4 (12)

## DIMENSIONS – OUTDOOR

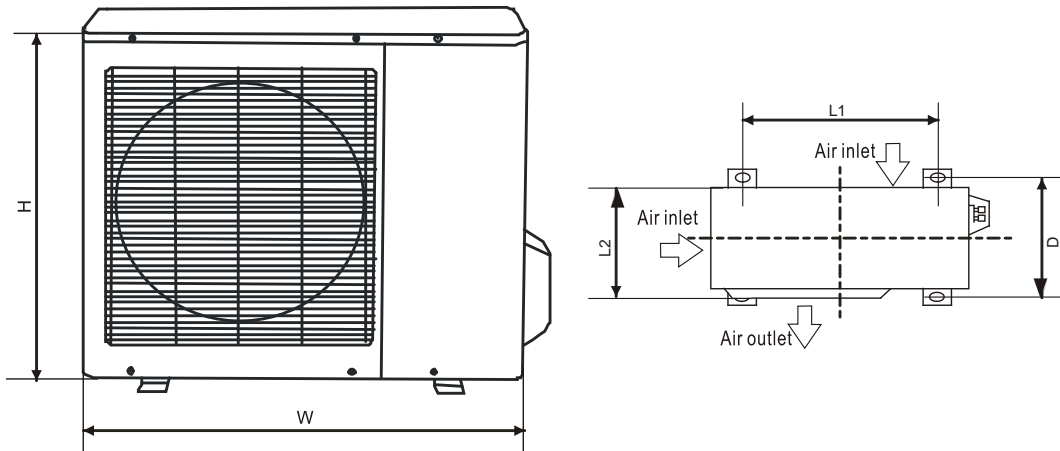

Fig. 2 – Dimensions – Outdoor

A14344

Table 6—Dimensions Outdoor

Model	W in (mm)	D in (mm)	H in (mm)	L1 in (mm)	L2 in (mm)	HP Operating Weight lb (kg)	AC Operating Weight lb (kg)
9K	30.7 (780)	9.8 (250)	21.2 (540)	21.6 (549)	10.9 (276)	70.5 (32.0)	58.4 (26.5)
12K	30.7 (780)	9.8 (250)	21.2 (540)	21.6 (549)	10.9 (276)	70.5 (32.0)	61.7 (28.0)
17K HP / 18K AC	29.9 (760)	11.2 (285)	23.2 (590)	20.9 (530)	11.4 (290)	82.7 (37.5)	76.0 (47.0)
22K	33.3 (845)	12.6 (320)	27.6 (700)	22.0 (560)	13.2 (335)	103.6 (47.0)	98.1 (44.5)

## CLEARANCES – INDOOR

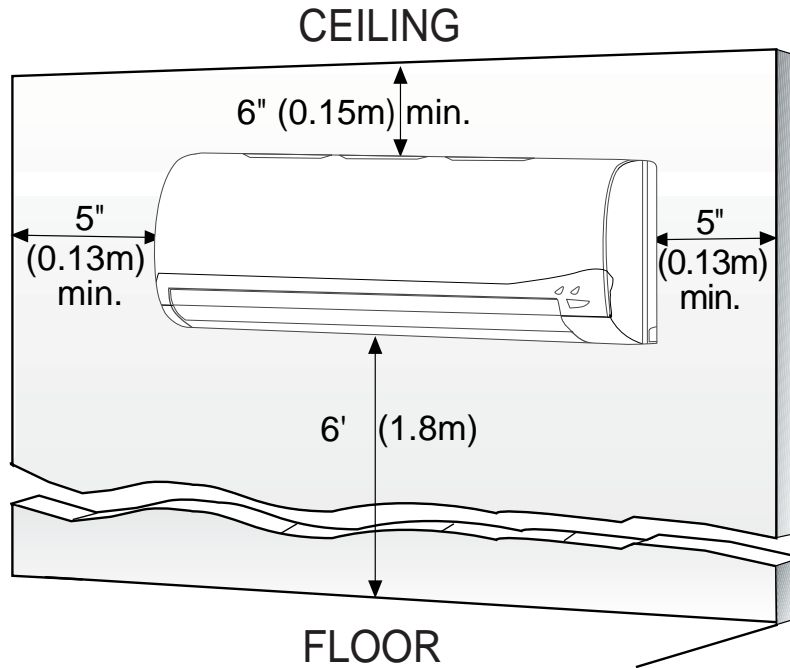

Fig. 3 – Indoor Unit Clearance

A07891

## CLEARANCES – OUTDOOR

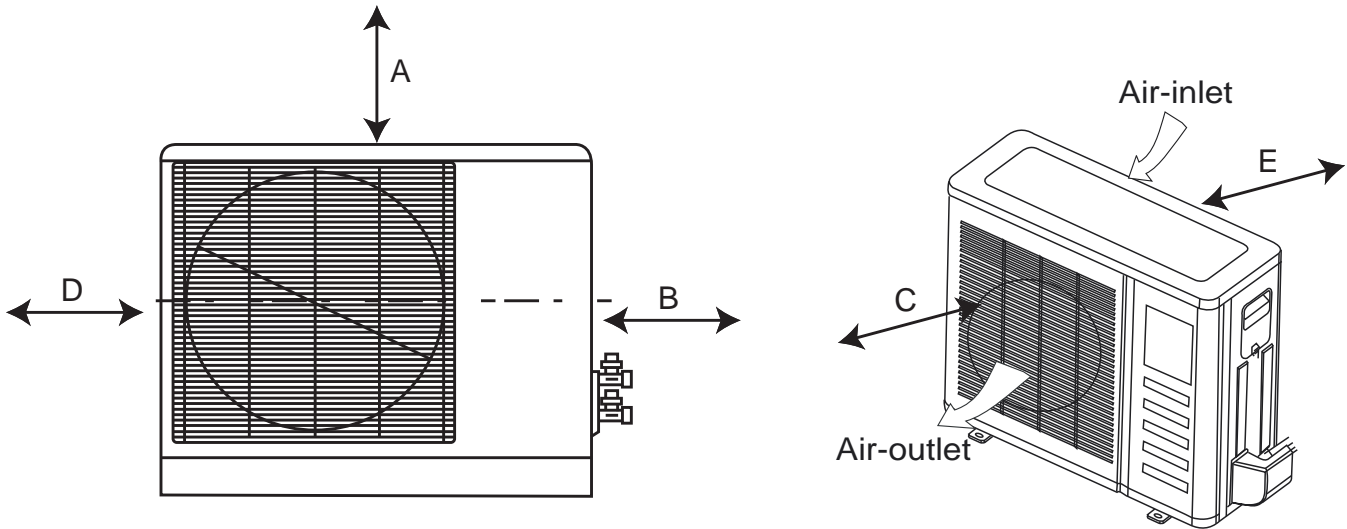

Fig. 4 – Outdoor Unit Clearance

A07894

Table 7—Outdoor Unit Clearance Dimensions

UNIT	Minimum Value in. (mm)
A	24 (609)
B	24 (609)
C	24 (609)
D	4 (101)
E	4 (101)

**NOTE:** The outdoor unit must be mounted at least 2in (50mm) above the maximum anticipated snow depth.

# INSTALLATION TIPS

## Ideal installation locations include:

### Indoor Unit

- A location where there are no obstacles near inlet and outlet area.
- A location which can bear the weight of indoor unit.
- Do not install indoor units near a direct source of heat such as direct sunlight or a heating appliance.
- A location which provides appropriate clearances as outlined in Fig. 3.

### Outdoor Unit

- A location which is convenient to installation and not exposed to strong wind.
- A location which can bear the weight of outdoor unit and where the outdoor unit can be mounted in a level position.
- A location which provides appropriate clearances as outlined in Fig. 4.
- Do not install the indoor or outdoor units in a location with special environmental conditions. For those applications, contact your Ductless representative.

## INDOOR UNIT INSTALLATION

### INSTALL MOUNTING PLATE

The mounting plate will look like one of the following (see Fig. 5 – 8) depending on model size.

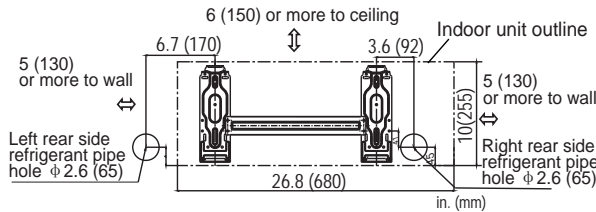

Fig. 5 – Mounting Plate– Model size 009

A14345

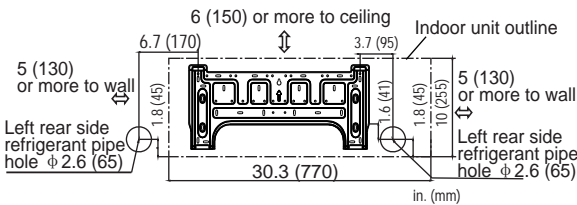

Fig. 6 – Mounting Plate– Model size 012

A14346

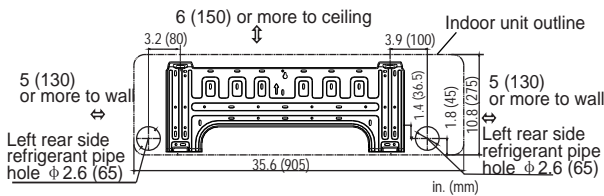

Fig. 7 – Mounting Plate– Model sizes 017 (AC) / 018 (HP)

A14347

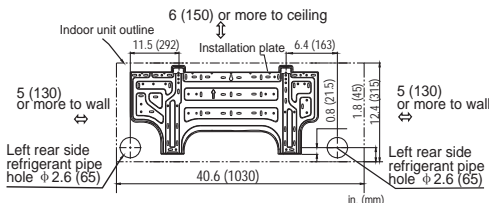

Fig. 8 – Mounting Plate– Model size 022

A14348

1. Carefully remove the mounting plate, which is attached to the back of the indoor unit.
2. The mounting plate should be located horizontally and level on the wall. All minimum spacings shown in Fig. 3 and 5 through 8 should be maintained.
3. If the wall is block, brick, concrete or similar material, drill .2” (5 mm) diameter holes and insert anchors for the appropriate mounting screws.
4. Attach the mounting plate to the wall.

## DRILL HOLE IN WALL FOR INTERCONNECTING PIPING, DRAIN AND WIRING

### Refrigerant Line Routing

The refrigerant lines may be routed in any of the four directions shown in Fig. 10.

For maximum serviceability, it is recommended to have refrigerant line flare connections and the drain connections on the outside of the wall that the fan coil can be mounted on.

### If piping is going through the back:

1. Determine pipe hole position using the mounting plate as a template. Drill pipe hole diameter per values given in Fig. 5 through 8. The outside pipe hole is 1/2-in. (13 mm) min. lower than inside pipe hole, so it slants slightly downward (see Fig. 9).

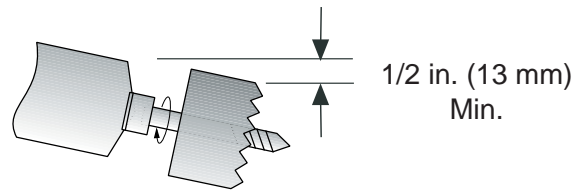

INDOOR

OUTDOOR

Fig. 9 – Drill Holes

A07371

### If piping is going through the right or left side:

1. Use a small saw blade to carefully remove the corresponding plastic covering on side panel and drill the appropriate size hole where the pipe is going through the wall.

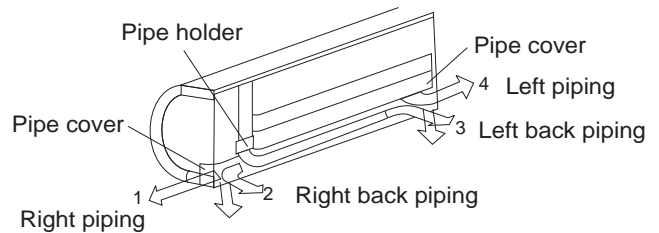

Fig. 10 – Piping Locations

A14349

## OUTDOOR UNIT INSTALLATION

1. Use a rigid base to support unit in a level position.
2. Locate outdoor unit and connect piping and wiring.



### CAUTION

#### EQUIPMENT DAMAGE HAZARD

Failure to follow this caution may result in equipment damage or improper operation.

In regions with snowfall and cold temperatures, avoid installing the outdoor unit in areas where it can be covered by snow. If the outdoor unit is installed in areas where heavy snow is expected, a field supplied ice or snow stand and/or field supplied—installed wind baffle should be installed to protect the unit from snow accumulation and/or blocked air intake. Blocking the air intake may result in reduced airflow, significantly reduced performance and damage to the equipment.

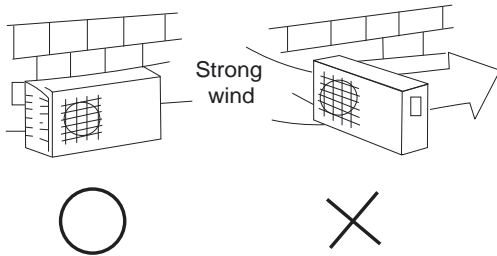

Fig. 11 — High Wind Installation

A07350

### MAKE REFRIGERANT PIPING CONNECTIONS (OUTDOOR UNIT)

**IMPORTANT:** Use refrigeration grade tubing **ONLY**. No other type of tubing may be used. Use of other types of tubing will void manufacturer's warranty.

Do not open service valves or remove protective caps from tubing ends until all the connections are made.

Bend tubing with bending tools to avoid kinks and flat spots.

Keep the tubing free of dirt, sand, moisture, and other contaminants to avoid damaging the refrigerant system.

Avoid sags in the suction line to prevent the formation of oil traps. Insulate each tube with minimum 3/8-in. (10 mm) wall thermal pipe insulation. Inserting the tubing into the insulation before making the connections will save time and improve installation quality.

1. Remove service valve cover if provided with unit.
2. Cut tubing with tubing cutter. Remove service connection if provided with unit.
3. Install correct size flare nut onto tubing and make flare connection.
4. Apply a small amount of refrigerant oil to the flare connection on the tubing.
5. Properly align tubing in with service valve.
6. Tighten flare nut and finish installation using two wrenches as shown in Fig. 12.

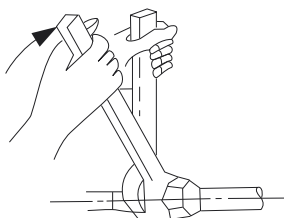

Fig. 12 — Tighten Flare Nut

A07354



### CAUTION

#### EQUIPMENT DAMAGE HAZARD

Failure to follow this caution may result in equipment damage or improper operation.

Excessive torque can break flare nut depending on installation conditions.

### INSTALL ALL POWER AND INTERCONNECTING WIRING TO OUTDOOR UNITS

1. Mount outdoor power disconnect.
2. Run power wiring from main box to disconnect per NEC and local codes.
3. Remove field wiring cover from unit by loosening screws.
4. Remove caps on conduit panel.
5. Connect conduit to conduit panel (see Fig.13).
6. Properly connect both power supply and control lines to terminal block per the connection diagram for the appropriate unit capacity and voltage (see Fig. 14).
7. Ground unit in accordance with NEC and local electrical codes.
8. Use lock nuts to secure conduit.
9. Reinstall field wiring cover.



### CAUTION

#### EQUIPMENT DAMAGE HAZARD

Failure to follow this caution may result in equipment damage or improper operation.

- Be sure to comply with local codes while running wire from indoor unit to outdoor unit.
- Every wire must be connected firmly. Loose wiring may cause terminal to overheat or result in unit malfunction. A fire hazard may also exist. Therefore, be sure all wiring is tightly connected.
- No wire should be allowed to touch refrigerant tubing, compressor or any moving parts.
- Disconnecting means must be provided and shall be located within sight and readily accessible from the air conditioner.
- Connecting cable with conduit shall be routed through hole in the conduit panel.

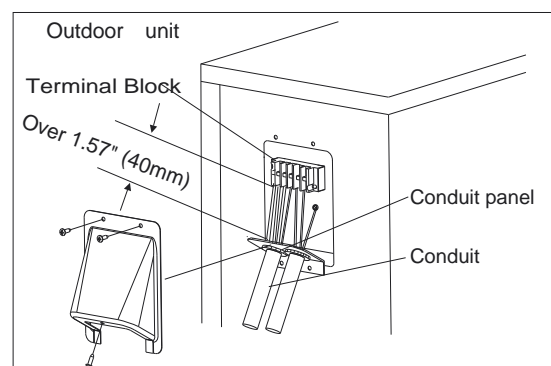

Fig. 13 — Field Wiring

A07455

# ELECTRICAL DATA

**Table 8—Electrical Data**

UNIT SIZE	OPER. VOLTAGE MAX / MIN	COMPRESSOR			OUTDOOR FAN				INDOOR FAN				MCA	MAX FUSE CB AMP
		V-PH-HZ	RLA	LRA	V-PH-HZ	FLA	HP	W	V-PH-HZ	FLA	HP	W		
9K	127 / 104	115-1-60	5.30	10	115-1-60	0.7	0.31	23	115-1-60	0.3	0.020	15	19	30
12K														
12K	253 / 187	208-230-1-60	5.30	10	208-230-1-60	0.3	0.33	24	208-230-1-60	0.2	0.027	20	10	15
017K (HP) / 018K (AC)			3.95	14		0.6	0.68	50		0.3	0.038	28	14	20
22K			9.70	17		0.6	0.72	53		0.4	0.061	45	16	25

## CONNECTION DIAGRAMS

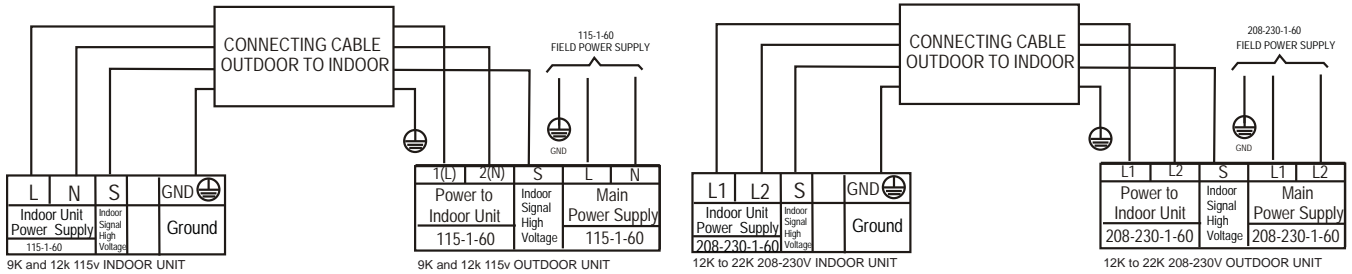

**Fig. 14 – Connection Diagrams**

A14506

**Notes:**

- Do not use thermostat wire for any connection between indoor and outdoor units.
- All connections between indoor and outdoor units must be as shown. **The connections are sensitive to polarity and will result in a fault code.**

### INSTALL ALL POWER, INTERCONNECTING WIRING, AND PIPING TO THE INDOOR UNIT

- Run interconnecting piping and wiring from outdoor unit to indoor unit.
- Run interconnecting cable through hole in wall (outside to inside).
- Lift indoor unit into position and route piping and drain through hole in wall (inside to outside). Fit interconnecting wiring into back side of indoor unit.
- Put upper claw at back of indoor unit on upper hook of Mounting Plate, move indoor unit from side to side to see that it is securely hooked.
- Open front cover of indoor unit and remove field wiring terminal block cover.
- Pull interconnecting wire up from back of indoor unit and position in close to the terminal block on indoor unit.
- Push lower part of indoor unit up on wall, then move indoor unit from side to side, up and down to check if it is hooked securely (see Fig. 15).

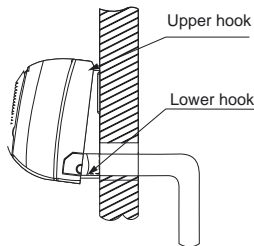

**Fig. 15 – Indoor Unit Installation**

A07347a

- Connect refrigerant piping and drain line outside of indoor unit. Refer to Fig. 12 for proper installation of flare connections. Complete pipe insulation at flare connection then fasten piping and wiring to the wall as required. Completely seal the hole in the wall.
- Connect the drain line. The drain line must not have a trap anywhere in its length, must pitch downwards, and must be insulated up to the outside wall (see Fig. 16).

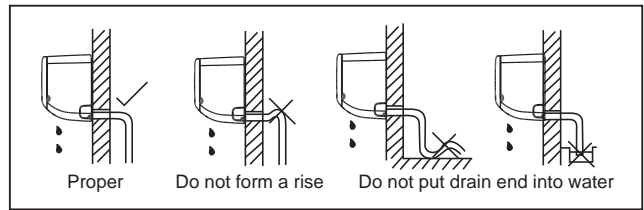

A14351

**Fig. 16 – Proper Drain Hose Installation**

**NOTE:** For proper orientation of the refrigerant piping, electrical cable and drain lines, refer to Fig. 17.

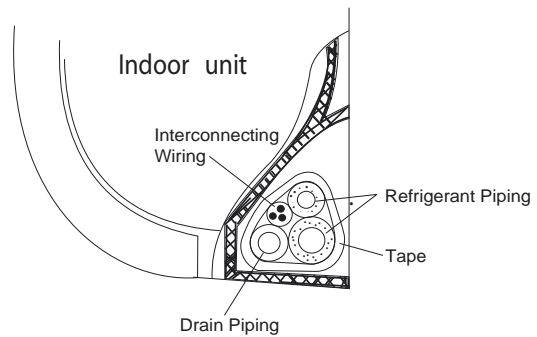

**Fig. 17 – Proper Orientation**

A07346

- Connect wiring from outdoor unit per connection diagram (see Fig. 14 and Fig. 18).
- Replace field wiring cover and close front cover of indoor unit.

**NOTE:** For applications where gravity cannot be used for drainage, a condensate pump accessory is available. Consult the condensate pump Installation Instructions for more information.

## REMOTE CONTROL INSTALLATION

### Mounting Bracket (if installed on the wall)

1. Use the two screws supplied with control to attach Mounting Bracket to wall in location selected by customer and within operating range.
2. Install batteries in Remote Control.
3. Place Remote Control into remote control Mounting Bracket.
4. For remote control operation, refer to the unit Owner's Manual.

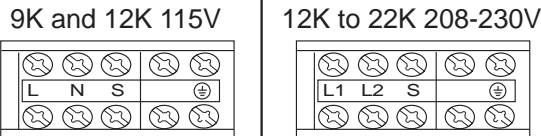
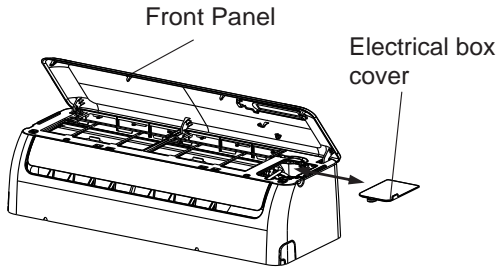

Fig. 18 – Control and Power Wiring on Indoor Unit

A14352

**⚠ CAUTION**

**UNIT DAMAGE HAZARD**

Failure to follow this caution may result in equipment damage or improper operation.

Never use the system compressor as a vacuum pump.

Refrigerant tubes and indoor coil should be evacuated using the recommended deep vacuum method of 500 microns. The alternate triple evacuation method may be used if the procedure outlined below is followed. Always break a vacuum with dry nitrogen.

## SYSTEM VACUUM AND CHARGE

### Using Vacuum Pump

1. Completely tighten flare nuts A, B, C, D, connect manifold gage charge hose to a charge port of the low side service valve. (see Fig. 19).
2. Connect charge hose to vacuum pump.
3. Fully open the low side of manifold gage (see Fig. 20).
4. Start vacuum pump
5. Evacuate using either deep vacuum or triple evacuation method.
6. After evacuation is complete, fully close the low side of manifold gage and stop operation of vacuum pump.
7. The factory charge contained in the outdoor unit is good for up to 25 ft. (8 m) of line length. For refrigerant lines longer than 25 ft. (8 m), add refrigerant, up to the allowable length, as specified in the System Requirements section.
8. Disconnect charge hose from charge connection of the low side service valve.

9. Fully open service valves B and A.
10. Securely tighten caps of service valves.

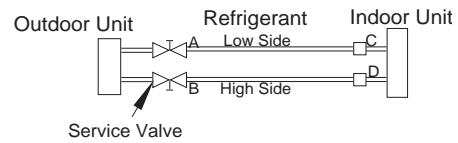

Fig. 19 – Service Valve

A07360

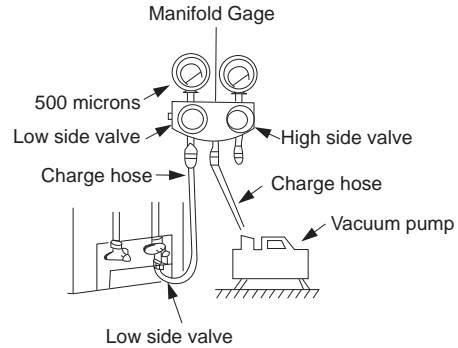

Fig. 20 – Manifold

A07361

### Deep Vacuum Method

The deep vacuum method requires a vacuum pump capable of pulling a vacuum of 500 microns and a vacuum gage capable of accurately measuring this vacuum depth. The deep vacuum method is the most positive way of assuring a system is free of air and liquid water (see Fig. 21).

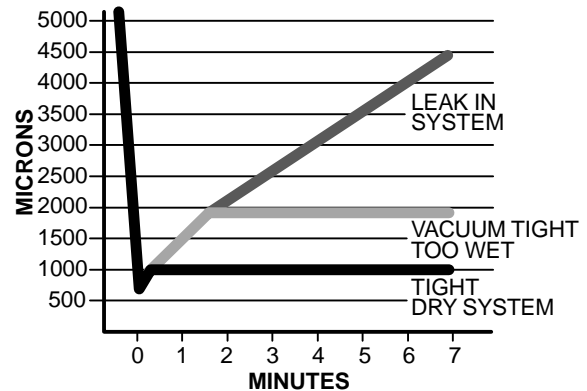

Fig. 21 – Deep Vacuum Graph

A95424

### Triple Evacuation Method

The triple evacuation method should only be used when vacuum pump is only capable of pumping down to 28 in. of mercury vacuum and system does not contain any liquid water. Refer to Fig. 22 and proceed as follows:

1. Pump system down to 28 in. of mercury and allow pump to continue operating for an additional 15 minutes.
2. Close service valves and shut off vacuum pump.
3. Connect a nitrogen cylinder and regulator to system and open until system pressure is 2 psig.
4. Close service valve and allow system to stand for 1 hr. During this time, dry nitrogen will be able to diffuse throughout the system absorbing moisture.
5. Repeat this procedure as indicated in Fig. 22. System will then be free of any contaminants and water vapor.

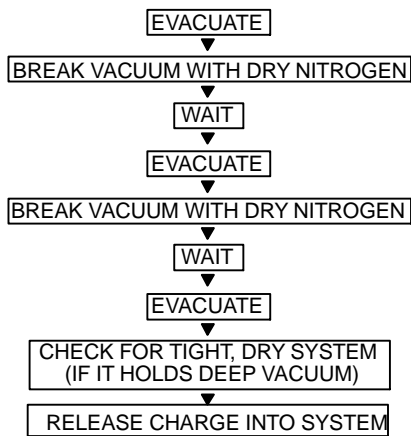

A95425

Fig. 22 — Triple Evacuation Method

### Final Tubing Check

**IMPORTANT:** Check to be certain factory tubing on both indoor and outdoor unit has not shifted during shipment. Ensure tubes are not rubbing against each other or any sheet metal. Pay close attention to feeder tubes, making sure wire ties on feeder tubes are secure and tight.

## START-UP

### Test Operation

Perform test operation after completing gas leak and electrical safety check (see Fig. 23).

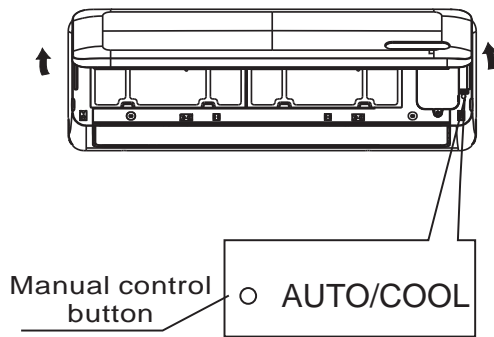

A14353

Fig. 23 — Test Operation

1. Push the “ON/OFF” button on Remote Control to begin testing.

**NOTE:** A protection feature prevents air conditioner from being activated for approximately 3 to 4 minutes.

2. Push MODE button, select COOLING, HEATING, FAN mode to check if all functions work correctly.
3. To run the test using the manual button in the indoor unit:
  - (1.) Open front panel of the indoor unit;
  - (2.) Push the manual switch once to energize the unit. The set conditions of manual operation are as follows:
    - Preset set point: 76°F (24°C)
    - Fan speed: AUTO
    - Discharge air direction: Pre-set position based on operation in “Cool” or “Heat” mode.
4. Be sure to set manual switch to “OFF” (by pushing it twice again) after finishing test operation.

**NOTE:** For Heat Pumps, follow the same procedure.

## SYSTEM CHECKS

1. Conceal the tubing where possible.
2. Make sure that the drain tube slopes downward along its entire length.
3. Ensure all tubing and connections are properly insulated.
4. Fasten tubes to the outside wall, when possible.
5. Seal the hole through which the cables and tubing pass.

## INDOOR UNIT

1. Do all Remote Control buttons function properly?
2. Do the display panel lights work properly?
3. Does the air deflection louver function properly?
4. Does the drain work?

## OUTDOOR UNIT

1. Are there unusual noises or vibrations during operation?

### Explain Following Items To Customer (with the aid of the Owner’s Manual):

1. How to turn air conditioner on and off; selecting COOLING, HEATING and other operating modes; setting a desired temperature; setting the timer to automatically start and stop air conditioner operation; and all other features of the Remote Control and display panel.
2. How to remove and clean the air filter.
3. How to set air deflection louver.
4. Explain care and maintenance.
5. Present the Owner’s Manual and installation instructions to customer.

## TROUBLESHOOTING

For ease of service, the systems are equipped with diagnostic code display LEDs on both the indoor and outdoor units. The outdoor diagnostic display is two LEDs (Red and Green) on the outdoor unit board and is limited to very few errors. The indoor diagnostic display is a combination of flashing LEDs on the display panel or

the front of the unit. If possible, always check the diagnostic codes displayed on the indoor unit first.

The diagnostic codes displayed in the indoor and outdoor units are listed in the Tables 9 and 10.

### INDOOR UNIT DIAGNOSTIC GUIDES

**Table 9—Indoor Unit Diagnostic Guides**

OPERATION LAMP	TIMER LAMP	DISPLAY	FAILURE MODE
☆ 1 time	X	E0	Indoor unit EEPROM parameter error
☆ 2 times	X	E1	Indoor / outdoor units communication error
☆ 3 times	X	E2	Zero-crossing signal detection error
☆ 4 times	X	E3	Indoor fan speed has been out of control
☆ 5 times	X	E4	Indoor room temperature sensor is open circuit or short circuited
☆ 6 times	X	E5	Evaporator coil temperature sensor is open circuit or short circuited
☆ 2 times	On	F1	Outdoor temperature sensor is open circuit or short circuited
☆ 3 times	On	F2	Condenser coil temperature sensor is open circuit or short circuited
☆ 4 times	On	F3	Compressor discharge temperature sensor is open circuit or short circuited
☆ 5 times	On	F4	Outdoor unit EEPROM parameter error
☆ 1 times	☆	P0	IPM malfunction or IGBT over-strong current protection
☆ 2 times	☆	P1	High or low voltage low voltage protection activated
☆ 5 times	☆	P4	Inverter compressor drive error

☆ = Flashing, X = Off

For additional diagnostic information, refer to the Service Manual

### OUTDOOR UNIT DIAGNOSTIC GUIDES

**Table 10—Outdoor Unit Diagnostic Guides**

GREEN LED	RED LED	FAILURE MODE
On	X	Standby, normal
X	On	Operation, normal
On	On	High/Low voltage protection on compressor terminal
On	☆	EEPROM error
X	☆	Compressor's speed is out of control
☆	On	Zero-crossing signal detection error; lack of phase; synchronization error
☆	X	IGBT or Module protection
☆	☆	Communication error

☆ = Flashing, X = Off

For additional diagnostic information, refer to the Service Manual