



Installation Instructions

NOTE: Read the entire instruction manual before starting the installation.

NOTE: Installer: Make sure the Owner's Manual and Service Instructions are left with the unit after installation.

TABLE OF CONTENTS

	PAGE
SAFETY CONSIDERATIONS	1
INTRODUCTION	2
RECEIVING AND INSTALLATION	2-9
Check Equipment	2
Identify Unit	2
Inspect Shipment	2
Provide Unit Support	2
Roof Curb	2
Slab Mount	2
Ground Mount	2
Provide Clearances	2
Rig and Place Unit	2
Inspection	2
Use of Rigging Bracket	3
Select and Install Ductwork	6
Converting Horizontal Discharge Units to Downflow (Vertical) Discharge Units	8
Provide for Condensate Disposal	8
Install Electrical Connections	8
High-Voltage Connections	8
Special Procedures for 208-V Operation	9
Control Voltage Connections	9
Standard Connections	9
Transformer Protection	9
Accessory Electric Heaters Installation	9
607C Sequence of Operation	9
PRE-START-UP	15
START-UP	15-17
Checking Cooling & Heating Control Operation	15
Check for Refrigerant Leaks	15
Start-Up Adjustments	15
Checking & Adjusting Refrigerant Charge	16
Indoor Airflow & Airflow Adjustments	16
Continuous Fan Operation	16
Defrost Control	17
Quiet Shift	17
Defrost	17
MAINTENANCE	18-23
Air Filter	18
Indoor Blower and Motor	18
Outdoor Coil, Indoor Coil, & Condensate Drain Pan	20
Outdoor Fan	21
Electrical Controls and Wiring	21
Refrigerant Circuit	21
Indoor Airflow	21
Metering Devices- TXV & Piston	21
Pressure Switches	22
Loss of Charge Switch	22
High Pressure Switch	22
Copeland Scroll compressor (Puron Refrigerant)	22

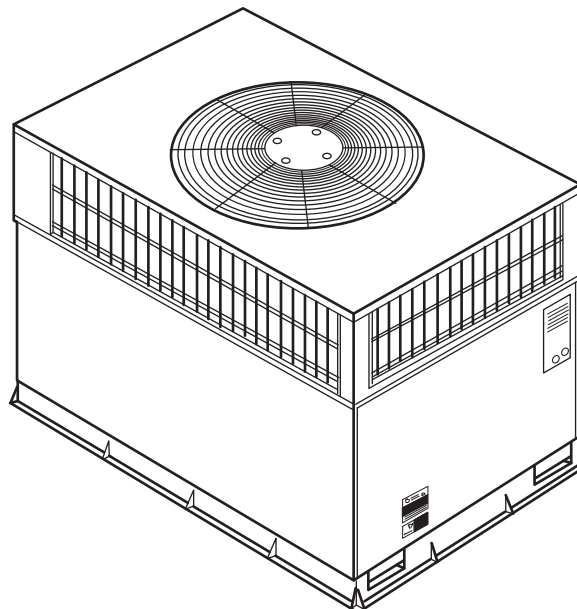

C99062

Fig. 1 - Unit 607C

Refrigerant System	22
Refrigerant	22
Compressor Oil	22
Servicing Systems on Roofs with Synthetic Materials	22
Liquid Line Filter Drier	23
Puron® (R-410A) Refrigerant Charging	23
System Information	23
Loss of Charge Switch	23
Check Defrost Thermostat	23
TROUBLESHOOTING	23
START-UP CHECKLIST	23

SAFETY CONSIDERATIONS

Installation and servicing of this equipment can be hazardous due to mechanical and electrical components. Only trained and qualified personnel should install, repair, or service this equipment. Untrained personnel can perform basic maintenance functions such as cleaning and replacing air filters. All other operations must be performed by trained service personnel. When working on this equipment, observe precautions in the literature, on tags, and on labels attached to or shipped with the unit and other safety precautions that may apply.

Follow all safety codes. Installation must be in compliance with local and national building codes. Wear safety glasses, protective clothing, and work gloves. Have fire extinguisher available. Read these instructions thoroughly and follow all warnings or cautions included in literature and attached to the unit.

Recognize safety information. This is the safety-alert symbol . When you see this symbol on the unit and in instructions or manuals, be alert to the potential for personal injury. Understand these signal words: DANGER, WARNING, and CAUTION. These words are used with the safety-alert symbol. DANGER identifies the most serious hazards which **will** result in severe personal injury or death. WARNING signifies hazards which **could** result in per-

sonal injury or death. CAUTION is used to identify unsafe practices which **may** result in minor personal injury or product and property damage. NOTE is used to highlight suggestions which **will** result in enhanced installation, reliability, or operation.

WARNING

ELECTRICAL SHOCK HAZARD

Failure to follow this warning could result in personal injury or death.

Before installing or servicing system, always turn off main power to system. There may be more than one disconnect switch. Turn off accessory heater power switch if applicable. TAG THE DISCONNECT SWITCH WITH A SUITABLE WARNING LABEL.

WARNING

FIRE, EXPLOSION, ELECTRICAL SHOCK AND CARBON MONOXIDE POISONING HAZARD

Failure to follow this warning could result in personal injury, death or property damage.

A qualified installer or agency must use only factory-authorized kits or accessories when modifying this product.

INTRODUCTION

The 607C heat pump is fully self-contained and designed for outdoor installation. (See Fig. 1) Standard units are shipped in a horizontal-discharge configuration for installation on a groundlevel slab. Standard units can be converted to downflow (vertical) discharge configurations for rooftop applications.

RECEIVING AND INSTALLATION

Step 1 — Check Equipment

Identify Unit

The unit model number and serial number are stamped on the unit identification plate. Check this information against shipping papers.

Inspect Shipment

Inspect for shipping damage while unit is still on shipping pallet. If unit appears to be damaged or is torn loose from its anchorage, have it examined by transportation inspectors before removal. Forward claim papers directly to transportation company. Manufacturer is not responsible for any damage incurred in transit. Check all items against shipping list. Immediately notify the nearest equipment distributor if any item is missing. To prevent loss or damage, leave all parts in original packages until installation.

Step 2 — Provide Unit Support

Roof Curb

Install accessory roof curb in accordance with instructions shipped with curb (See Fig. 5). Install insulation, cant strips, roofing, and flashing. Ductwork must be attached to curb.

IMPORTANT: The gasketing of the unit to the roof curb is critical for a watertight seal. Install gasketing material supplied with the roof curb. Improperly applied gasketing also can result in air leaks and poor unit performance.

Curb should be level to within 1/4 in. (6 mm) (See Fig. 6). This is necessary for unit drain to function properly. Refer to accessory roof curb installation instructions for additional information as required.

Slab Mount

Place the unit on a solid, level concrete pad that is a minimum of 4 in. (102 mm) thick with 2 in. (51 mm) above grade (See Fig. 7). The slab should extend approximately 2 in. (51 mm) beyond the casing on all 4 sides of the unit. Do not secure the unit to the slab except when required by local codes.

Ground Mount

The unit may be installed either on a slab or placed directly on the ground if local codes permit. Place the unit on level ground prepared with gravel for condensate discharge.

Step 3 — Provide Clearances

The required minimum service clearances are shown in Fig. 2 and 3. Adequate ventilation and outdoor air must be provided. The outdoor fan draws air through the outdoor coil and discharges it through the top fan grille. Be sure that the fan discharge does not recirculate to the outdoor coil. Do not locate the unit in either a corner or under an overhead obstruction. The minimum clearance under a partial overhang (such as a normal house overhang) is 48 in. (1219 mm) above the unit top. The maximum horizontal extension of a partial overhang must not exceed 48 in. (1219 mm).

IMPORTANT: Do not restrict outdoor airflow. An air restriction at either the outdoor-air inlet or the fan discharge may be detrimental to compressor life.

Do not place the unit where water, ice, or snow from an overhang or roof will damage or flood the unit. Do not install the unit on carpeting or other combustible materials. Slab-mounted units should be at least 4 in. (102 mm) above the highest expected water and runoff levels. Do not use unit if it has been under water.

Step 4 — Rig and Place Unit

Rigging and handling of this equipment can be hazardous for many reasons due to the installation location (roofs, elevated structures, etc.).

Only trained, qualified crane operators and ground support staff should handle and install this equipment.

When working with this equipment, observe precautions in the literature, on tags, stickers, and labels attached to the equipment, and any other safety precautions that might apply.

Training for operators of the lifting equipment should include, but not be limited to, the following:

1. Application of the lifter to the load, and adjustment of the lifts to adapt to various sizes or kinds of loads.
2. Instruction in any special operation or precaution.
3. Condition of the load as it relates to operation of the lifting kit, such as balance, temperature, etc.

Follow all applicable safety codes. Wear safety shoes and work gloves.

INSPECTION

The lifting/rigging bracket is engineered and designed to be installed *only* on Small Packaged Products. This bracket is to be used to rig/lift a Small Packaged Product onto roofs or other elevated structures.

Prior to initial use, and at monthly intervals, all rigging brackets and straps should be visually inspected for any damage, evidence of wear, structural deformation, or cracks. Particular attention should be paid to excessive wear at hoist hooking points and load support areas. Brackets or straps showing any kind of wear in these areas must not be used and should be discarded.

⚠ WARNING

UNIT FALLING HAZARD

Failure to follow this warning could result in personal injury or death.

Never stand beneath rigged units or lift over people.

⚠ WARNING

PROPERTY DAMAGE HAZARD

Failure to follow this warning could result in personal injury/death or property damage.

Rigging brackets for one unit use only. When removing a unit at the end of its useful life, use a new set of brackets.

USE OF RIGGING BRACKET

Field Installation of Rigging Bracket (if not already installed)

1. Remove unit from shipping carton. Leave top shipping skid on the unit for use as a spreader bar to prevent the rigging straps from damaging the unit. If the skid is not available, use a spreader bar of sufficient length to protect the unit from damage.
2. Remove 4 screws in unit corner posts.
3. Attach each of the 4 metal rigging brackets under the panel rain lip. Use the screws removed in step 2 above to secure the brackets to the unit.

⚠ WARNING

PROPERTY DAMAGE HAZARD

Failure to follow this warning could result in personal injury/death or property damage.

Rigging bracket **MUST** be under the rain lip to provide adequate lifting.

⚠ WARNING

PROPERTY DAMAGE HAZARD

Failure to follow this warning could result in personal injury/death or property damage.

Do not strip screws when re-securing the unit. If a screw is stripped, replace the stripped one with a larger diameter screw (included). When straps are taut, the clevis should be a minimum of 36 in. (914 mm) above the unit top cover.

Rigging/Lifting of Unit

1. Bend top of brackets down approximately 30 degrees from the corner posts.
2. Attach straps of equal length to the rigging brackets at opposite ends of the unit. Be sure straps are rated to hold the weight of the unit.
3. Attach a clevis of sufficient strength in the middle of the straps. Adjust the clevis location to ensure unit is lifted level with the ground.
4. Remove corner post screws and rigging brackets, then re-install screws.

After the unit is placed on the roof curb or mounting pad, remove the top crating.

UNIT	ELECTRICAL CHARACTERISTICS		UNIT WT.		CENTER OF GRAVITY IN/MM		
	LBS	KG	"A"	X	Y	Z	
607C024	208	139	39.0	27.0	11.8	18.0	
607C030	208	143	43.0	27.0	11.8	21.0	

CORNER WEIGHT LBS/KG	"1"		"2"		"3"		"4"	
	024	61/28	49/22	73/33	122/56	122/56	122/56	122/56
030	63/29	51/23	76/34	126/57	126/57	126/57	126/57	

REQUIRED CLEARANCES TO COMBUSTIBLE MATL.

	INCHES (MM)
TOP OF UNIT	14.00 (355.6)
DUCT SIDE OF UNIT	2.00 (50.8)
SIDE OPPOSITE DUCTS	14.00 (355.6)
BOTTOM OF UNIT	0.0 (0.0)
FLUE PANEL	36.00 (914.4)

NEC. REQUIRED CLEARANCES.

	INCHES (MM)
BETWEEN UNITS, POWER ENTRY SIDE	42.00 (1066.8)
UNIT AND UNGROUNDED SURFACES, POWER ENTRY SIDE	36.00 (914.0)
UNIT AND BLOCK OR CONCRETE WALLS AND OTHER GROUNDED SURFACES, POWER ENTRY SIDE	42.00 (1066.8)

REQUIRED CLEARANCE FOR OPERATION AND SERVICING

	INCHES (MM)
EVAP. COIL ACCESS SIDE	36.00 (914.4)
POWER ENTRY SIDE (EXCEPT FOR NEC REQUIREMENTS)	42.00 (1066.8)
UNIT TOP (EXCEPT FOR NEC REQUIREMENTS)	48.00 (1219.2)
SIDE OPPOSITE DUCTS	36.00 (914.4)
DUCT PANEL	12.00 (304.8)

*MINIMUM DISTANCES: IF UNIT IS PLACED LESS THAN 12.00 (304.8) FROM WALL SYSTEM, THEN SYSTEM PERFORMANCE MAYBE COMPROMISED.

DIMENSIONS IN () ARE IN MILLIMETERS

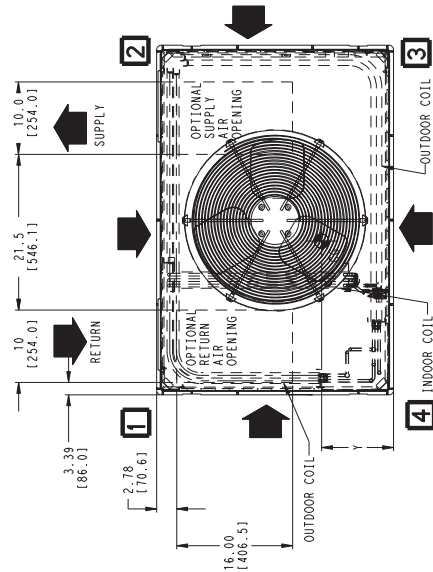

TOP VIEW

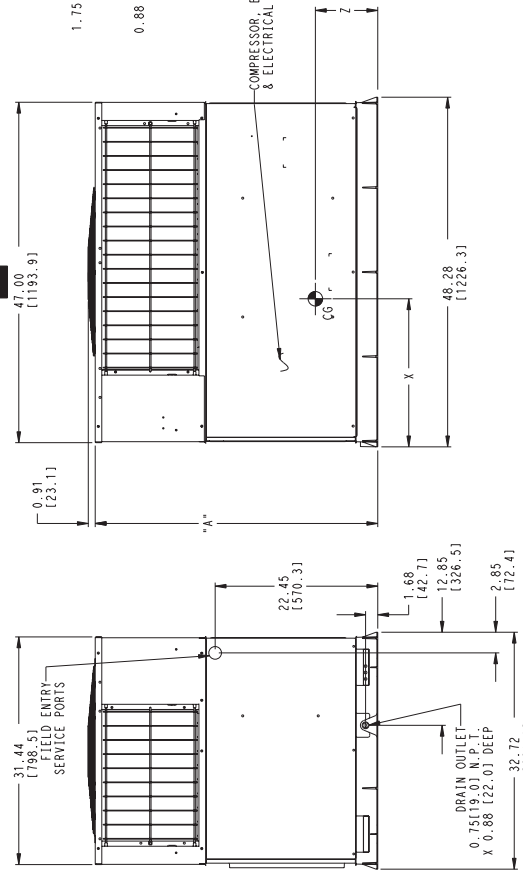

FRONT VIEW

LEFT SIDE VIEW

RIGHT SIDE VIEW

REAR VIEW

50VT500171 REV 2.0

Fig. 2 - 607C024-030 Unit Dimensions

UNIT	ELECTRICAL CHARACTERISTICS		CENTER OF GRAVITY IN/MM		
	LBS	KG	"A"	X	Z
607C036	371	168	41.0 [1041]	27.0 [687]	15.9 [404]
607C036	385	175	41.0 [1041]	26.7 [678]	15.3 [390]
607C042	412	187	47.0 [1194]	27.0 [687]	15.9 [404]
607C042	426	193	47.0 [1194]	26.7 [679]	15.4 [391]
607C048	432	196	47.0 [1194]	27.0 [687]	15.9 [404]
607C048	446	202	47.0 [1194]	26.7 [679]	15.4 [392]
607C060	462	210	51.0 [1295]	27.0 [687]	15.9 [404]
607C060	476	216	51.0 [1295]	26.7 [679]	15.5 [392]

UNITS Volts/99°	CORNER WEIGHT LB/KG		
	"1"	"2"	"3"
036	61/28	49/22	73/33
042	63/29	51/23	76/34
048	63/29	51/23	76/34
060	63/29	51/23	76/34

REQUIRED CLEARANCES TO COMBUSTIBLE MATL.

TOP OF UNIT..... 14.00 (355.6)
 DUCT SIDE OF UNIT..... 2.00 (50.8)
 SIDE OPPOSITE DUCTS..... 14.00 (355.6)
 BOTTOM OF UNIT..... 0 0 (0.0)
 ELECTRIC HEAT PANEL..... 36.00 (914.4)
 NEC. REQUIRED CLEARANCES.

BETWEEN UNITS, POWER ENTRY SIDE..... 42.00 (1066.8)
 UNIT AND UNGROUNDED SURFACES, POWER ENTRY SIDE..... 36.00 (914.0)
 UNIT AND BLOCK OR CONCRETE WALLS AND OTHER GROUNDED SURFACES, POWER ENTRY SIDE..... 42.00 (1066.8)

REQUIRED CLEARANCE FOR OPERATION AND SERVICING

EVAP. COIL ACCESS SIDE..... 36.00 (914.4)
 POWER ENTRY SIDE..... 42.00 (1066.8)
 UNIT TOP FOR NEC REQUIREMENTS..... 48.00 (1219.2)
 SIDE OPPOSITE DUCTS..... 36.00 (914.0)
 DUCT PANEL..... 12.00 (304.8)

*MINIMUM DISTANCES: IF UNIT IS PLACED LESS THAN 12.00 (304.8) FROM WALL SYSTEM, THEN SYSTEM PERFORMANCE MAYBE COMPROMISED.

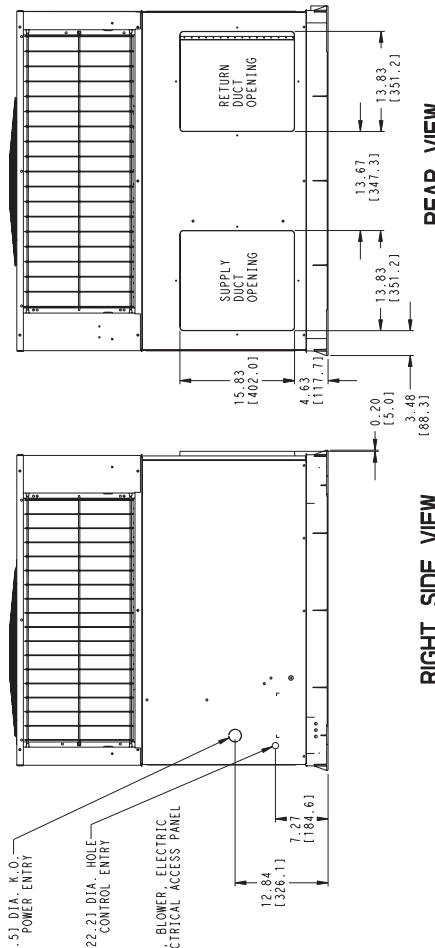
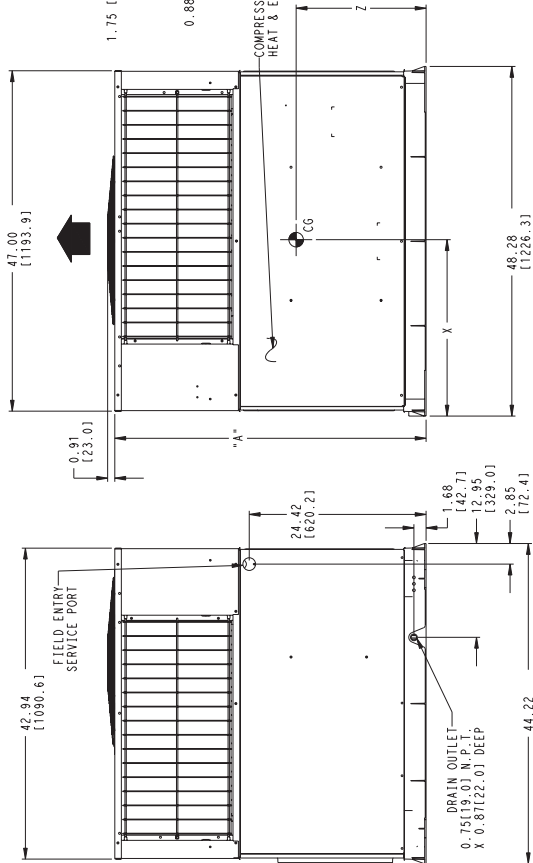
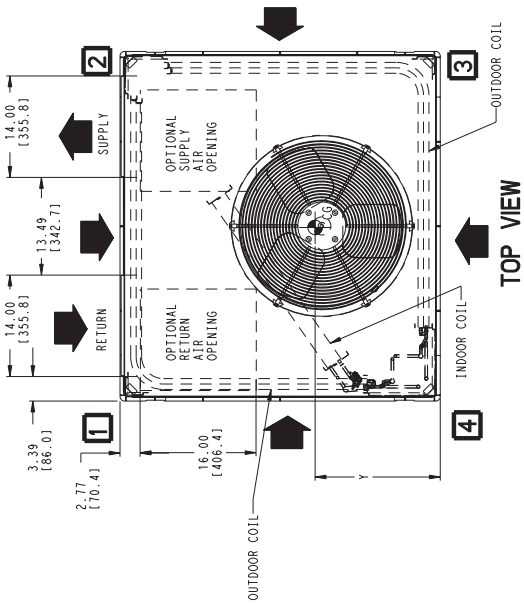

50VT500172
 REV 2.0

607C

Fig. 3 - 607C036-060 Unit Dimensions

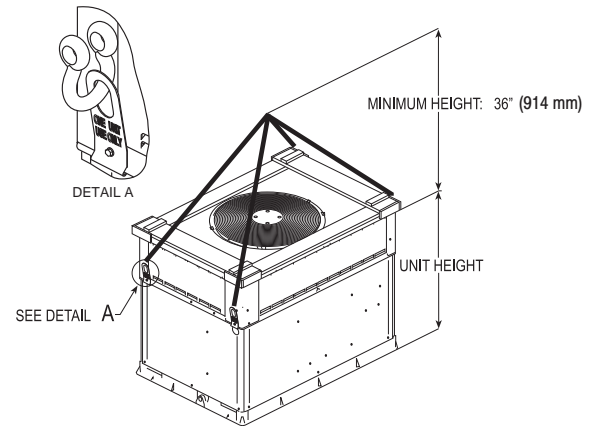
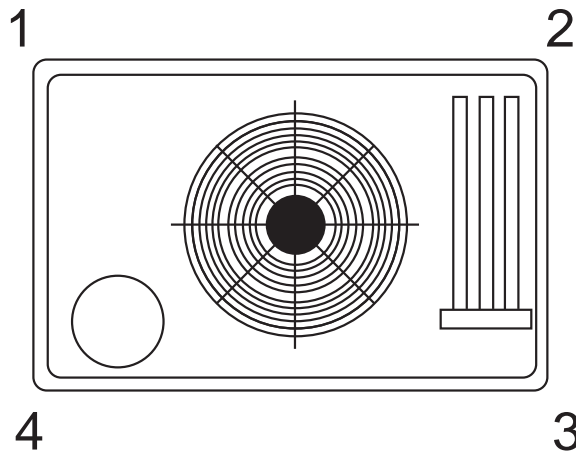

A08005

A08015

RIGGING WEIGHTS (SMALL CABINET)							RIGGING WEIGHTS (LARGE CABINET)						
Unit	024		030		036*		Unit	042*		048*		060*	
	lb	kg	lb	kg	lb	kg		lb	kg	lb	kg	lb	kg
Shipping Weight	354	171	364	165	419	190	Shipping Weight	464	210	484	220	514	233
Rigging Weight	317	144	327	148	382	173	Rigging Weight	427	164	447	203	477	216

* For 460 volt units, add 14 lb (6.4 kg) to the weight.

Fig. 4 - Rigging Weights

Step 5 — Select and Install Ductwork

The design and installation of the duct system must be in accordance with the standards of the NFPA for installation of non-residence type air conditioning and ventilating systems, NFPA 90A or residence-type, NFPA 90B and/or local codes and ordinances.

Select and size ductwork, supply-air registers, and return air grilles according to ASHRAE (American Society of Heating, Refrigeration, and Air Conditioning Engineers) recommendations.

The unit has duct flanges on the supply- and return-air openings on the side of the unit.

⚠ WARNING

PERSONAL INJURY HAZARD

Failure to follow this warning could result in personal injury or death.

For vertical supply and return units, tools or parts could drop into ductwork. Install a 90 degree turn in the return ductwork between the unit and the conditioned space. If a 90 degree elbow cannot be installed, then a grille of sufficient strength and density should be installed to prevent objects from falling into the conditioned space. Units with electric heaters require 90 degree elbow in supply duct.

When designing and installing ductwork, consider the following:

1. All units should have field-supplied filters or accessory filter rack installed in the return-air side of the unit. Recommended sizes for filters are shown in Table 1.
2. Avoid abrupt duct size increases and reductions. Abrupt change in duct size adversely affects air performance.

IMPORTANT: Use flexible connectors between ductwork and unit to prevent transmission of vibration. Use suitable gaskets to ensure weather tight and airtight seal. When electric heat is installed, use fireproof canvas (or similar heat resistant material) connector between ductwork and unit discharge connection. If flexible duct is used, insert a sheet metal sleeve inside duct. Heat resistant duct connector (or sheet metal sleeve) must extend 24-in. (610 mm) from electric heater element.

3. Size ductwork for cooling air quantity (cfm). The minimum air quantity for proper electric heater operation is listed in Table 2. Heater limit switches may trip at air quantities below those recommended.
4. Seal, insulate, and weatherproof all external ductwork. Seal, insulate and cover with a vapor barrier all ductwork passing through conditioned spaces. Follow latest Sheet Metal and Air Conditioning Contractors National Association (SMACNA) and Air Conditioning Contractors Association (ACCA) minimum installation standards for residential heating and air conditioning systems.
5. Secure all ducts to building structure. Flash, weatherproof, and vibration-isolate duct openings in wall or roof according to good construction practices.

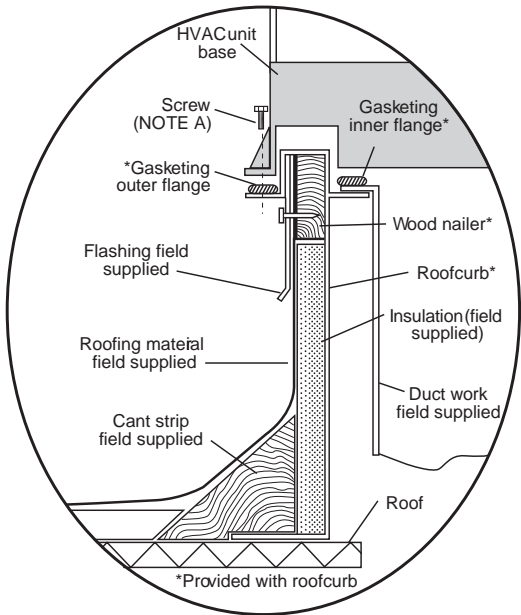

Roof Curb for Small Cabinet

Note A: When unit mounting screw is used retainer bracket must also be used.

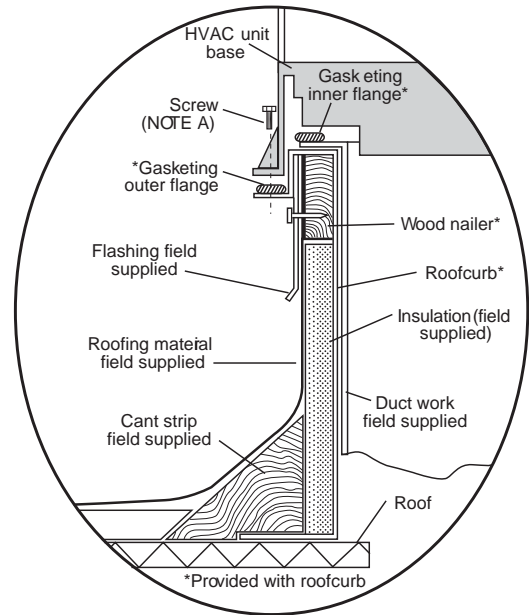

Roof Curb for Large Cabinet

Note A: When unit mounting screw is used retainer bracket must also be used.

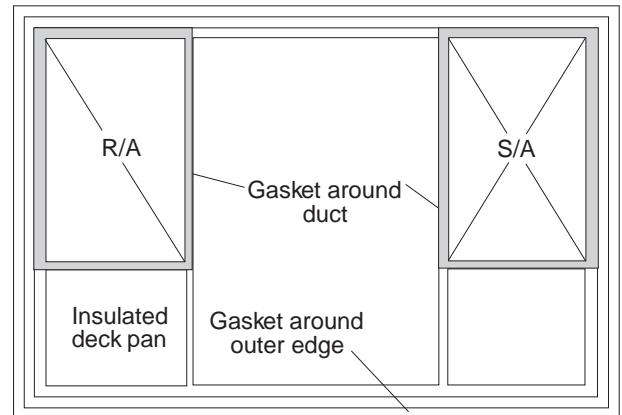
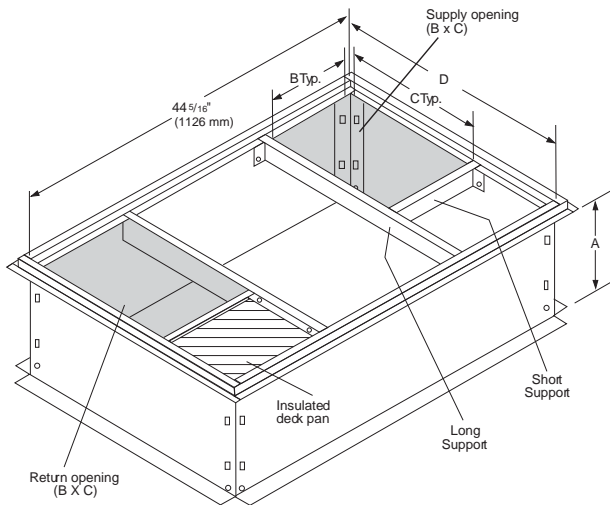

C00076

UNIT SIZE	CATALOG NUMBER	A IN. (MM)	B IN. (MM)	C IN. (MM)	D IN. (MM)
607C024-030	CPRFCURB006A00	8 (203)	11 (279)	16-1/2 (419)	28-3/4 (730)
	CPRFCURB007A00	14 (356)	11 (279)	16-1/2 (419)	28-3/4 (730)
607C036-060	CPRFCURB008A00	8 (203)	16-3/16 (411)	17-3/8 (441)	40-1/4 (1022)
	CPRFCURB009A00	14 (356)	16-3/16 (411)	17-3/8 (441)	40-1/4 (1022)

NOTES:

1. Roof curb must be set up for unit being installed.
2. Seal strip must be applied, as required, to unit being installed.
4. Dimension in () are in millimeters.
5. Roof curb is made of 16-gauge steel.
6. Attach ductwork to curb (flanges of duct rest on curb).
7. Insulated panels: 1-in. (25 mm) thick fiberglass 1 lb. density.
8. When unit mounting screw is used (see Note A), a retainer bracket must be used as well. This bracket must also be used when required by code for hurricane or seismic conditions. This bracket is available through Micrometl.

Fig. 5 - Roof Curb Dimensions

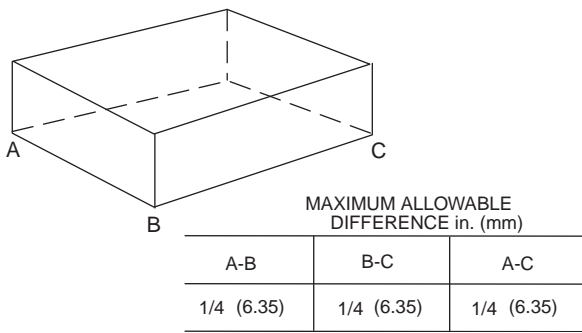

Fig. 6 - Unit Leveling Tolerances

A07925

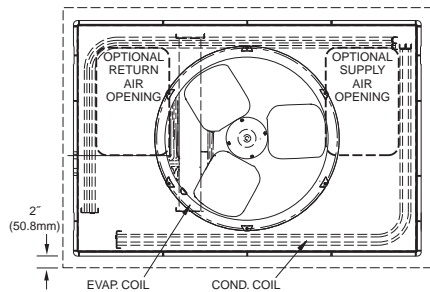

Fig. 7 - Slab Mounting Detail

A07926

Converting Horizontal Discharge Units to Downflow (vertical) Discharge Units

⚠ WARNING

ELECTRICAL SHOCK HAZARD

Failure to follow this warning could result in personal injury or death.

Before installing or servicing system, always turn off main power to system. There may be more than one disconnect switch. Tag the disconnect switch with a suitable warning label.

1. Open all electrical disconnects before starting any service work.
2. Remove horizontal duct covers to access bottom return and supply knock out panels.
3. Use a screwdriver and hammer to remove the panels in the bottom of the unit base.

NOTE: These panels are held in place with tabs similar to an electrical knockout.

4. Reinstall the horizontal duct covers (Fig. 10) to block off the horizontal air openings.

NOTE: Avoid abrupt duct size increases and reductions. Abrupt change in duct size adversely affects air performance.

Step 6 — Provide for Condensate Disposal

NOTE: Ensure that condensate-water disposal methods comply with local codes, restrictions, and practices.

The 607C units dispose of condensate through a 3/4 in. NPT female fitting that exits on the compressor end of the unit. Condensate water can be drained directly onto the roof in rooftop installations (where permitted) or onto a gravel apron in ground level installations. Install a field-supplied condensate trap at end of condensate connection to ensure proper drainage. Make sure that the outlet of the trap is at least 1 in. (25 mm) lower than the drain-pan condensate connection to prevent the pan from overflowing. Prime the trap with water. When using a gravel apron, make sure it slopes away from the unit.

If the installation requires draining the condensate water away from the unit, install a field-supplied 2 -in. (51mm) trap at the condensate connection to ensure proper drainage. Condensate trap is available as an accessory or is field-supplied. Make sure that the outlet of the trap is at least 1 in. (25 mm) lower than the unit drain-pan condensate connection to prevent the pan from overflowing. Connect a drain trough using a minimum of field-supplied 3/4-in. PVC or field-supplied 3/4-in. copper pipe at outlet end of the 2-in. (51 mm) trap. (See Fig. 11) Do not undersize the tube. Pitch the drain trough downward at a slope of at least 1 in. (25 mm) every 10 ft (3 m) of horizontal run. Be sure to check the drain trough for leaks. Prime the trap at the beginning of the cooling season start-up.

Step 7 — Install Electrical Connections

⚠ CAUTION

UNIT COMPONENT DAMAGE HAZARD

Failure to follow this caution may result in damage to the unit being installed.

1. Make all electrical connections in accordance with NEC NFPA 70 (latest edition) and local electrical codes governing such wiring. In Canada, all electrical connections must be in accordance with CSA standard C22.1 Canadian Electrical Code Part 1 and applicable local codes. Refer to unit wiring diagram.
2. Use only copper conductor for connections between field-supplied electrical disconnect switch and unit. DO NOT USE ALUMINUM WIRE.
3. Be sure that high-voltage power to unit is within operating voltage range indicated on unit rating plate. On 3-phase units, ensure phases are balanced within 2 percent. Consult local power company for correction of improper voltage and/or phase imbalance.
4. Do not damage internal components when drilling through any panel to mount electrical hardware, conduit, etc.

⚠ WARNING

ELECTRICAL SHOCK HAZARD

Failure to follow this warning could result in personal injury or death.

The unit cabinet must have an uninterrupted, unbroken electrical ground. This ground may consist of an electrical wire connected to the unit ground screw in the control compartment, or conduit approved for electrical ground when installed in accordance with NEC, NFPA 70 National Fire Protection Association (latest edition) (in Canada, Canadian Electrical Code CSA C22.1) and local electrical codes.

High-Voltage Connections

The unit must have a separate electrical service with a field-supplied, waterproof disconnect switch mounted at, or within sight from the unit. Refer to the unit rating plate, NEC and local codes for maximum fuse/circuit breaker size and minimum circuit amps (ampacity) for wire sizing.

The field-supplied disconnect may be mounted on the unit over the high-voltage inlet hole when the standard power and low-voltage entry points are used. See Fig. 2 and 3 for acceptable location. Remove high voltage knockout.

See unit wiring label (Fig. 12-14) and Fig. 8 for reference when making high voltage connections. Proceed as follows to complete the high-voltage connections to the unit.

607C

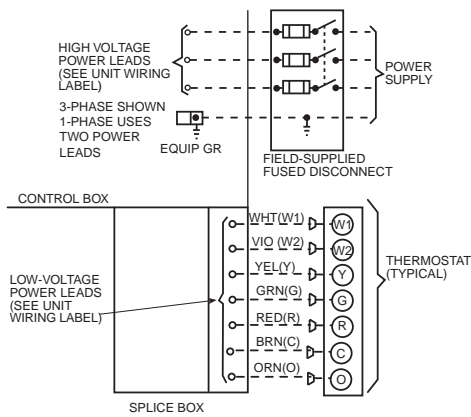

A08186

Fig. 8 - High- and Control-Voltage Connections

Single phase units:

1. Run the high-voltage (L1, L2) and ground lead into the control box.
2. Connect ground lead to chassis ground connection.
3. Locate the black and yellow wires connected to the line side of the contactor.
4. Connect field L1 to black wire on connection 11 of the compressor contactor.
5. Connect field wire L2 to yellow wire on connection 23 of the compressor contactor.

Three-phase units:

1. Run the high-voltage (L1, L2, L3) and ground lead into the control box.
2. Connect ground lead to chassis ground connection.
3. Locate the black and yellow wires connected to the line side of the contactor.
4. Connect field L1 to black wire on connection 11 of the compressor contactor.
5. Connect field wire L3 to yellow wire on connection 13 of the compressor contactor.
6. Connect field wire L2 to blue wire from compressor.

Special Procedures for 208-V Operation

⚠ WARNING

ELECTRICAL SHOCK HAZARD

Failure to follow this warning could result in personal injury or death.

Before installing or servicing system, always turn off main power to system. Tag the disconnect switch with a suitable warning label. With disconnect switch open, move black wire from transformer (3/16 in.) terminal marked 230 to terminal marked 208. This retaps transformer to primary voltage of 208 vac.

Control Voltage Connections

NOTE: Do not use any type of power-stealing thermostat. Unit control problems may result.

Use no. 18 American Wire Gage (AWG) color-coded, insulated (35°C minimum) wires to make the control voltage connections between the thermostat and the unit. If the thermostat is located more than 100 ft (30.5 m) from the unit (as measured along the control voltage wires), use no. 16 AWG color-coded, insulated (35° C minimum) wires.

Standard Connections

Locate the seven low voltage thermostat leads in 24 volt splice box. See Fig. 8 for connection diagram. Run the low-voltage leads from the thermostat, through the control wiring inlet hole grommet (Fig. 2 and 3), and into the low-voltage splice box. Provide a drip loop before running wires through panel. Secure and strain relief all wires so that they do not interfere with operation of unit.

If an accessory electric heater is installed, low voltage leads from heater must be connected to factory supplied control leads from Indoor Fan Board P4 connector. Factory wires are provided for electric heat staging W1 and W2 (W2 and W3 on IFB). If room thermostat has only one stage of supplemental heat, connect white and violet wires shown in Fig. 8 to second stage heat field wire.

Some electric heaters have four control wires (plus common wire). Consult unit wiring diagram and electric heater wiring diagram for additional details.

Transformer Protection

The transformer is of the energy-limiting type. It is set to withstand a 30-second overload or shorted secondary condition. If an overload or short is present, correct overload condition and check for blower fuse on control board. Replace fuse as required with correct size and rating.

Accessory Electric Heaters Installation

Electric heaters may be installed with the 607C units per instructions supplied with electric heater package. See unit rating plate for factory-approved electric heater kits.

607C Sequence of Operation

- a. CONTINUOUS FAN
 - (1.) Thermostat closes circuit R to G energizing the blower motor for continuous fan.
- b. COOLING MODE
 - (1.) If indoor temperature is above temperature set point, thermostat closes circuits R to G, R to Y and R to O-The unit delivers cooling airflow.
- c. ELECTRIC HEATING MODE
 - (1.) Thermostat closes circuit R to W/W1, or W2 and R to G. There are no on or off delays.
- d. HEAT PUMP HEATING MODE
 - (1.) Thermostat closes circuits R to G and R to Y. The compressor, indoor and outdoor fans are energized.
- e. HEAT PUMP HEATING WITH AUXILIARY ELECTRIC HEAT
 - (1.) Thermostat closes circuits R to G, R to Y and R to W/W1 or W2. The compressor, indoor and outdoor fans are energized, as well as the electric heat relays.
- f. DEFROST MODE

The defrost mode is automatically energized by the defrost board during heating mode. The defrost board energizes "O" (reversing valve) and "W2" (electric heat). It also de-energizes the outdoor fan. When defrost is complete, unit will return to heating mode. If room thermostat is satisfied during defrost, unit will shut down and restart in defrost on next call for heat.

607C

Table 1 – Physical Data - Unit 607C

UNIT SIZE	607C024	607C030	607C036	607C042	607C048	607C060
NOMINAL CAPACITY (ton)	2	2.5	3	3.5	4	5
OPERATING WEIGHT‡ (lb)	306	316	371	412	432	462
(kg)	139	143	168	187	196	210
COMPRESSOR QUANTITY	1					
TYPE	SCROLL COMPRESSOR					
REFRIGERANT	R-410A					
Refrigerant (R-410A) Quantity (lb)	9.5	10.5	9.0	14.0	17.0	16.0
Quantity (kg)	4.3	4.8	4.1	6.4	7.7	7.3
METERING DEVICE ID	TXV					
ORIFICE OD (in.)	0.032 (2)	0.038 (2)	0.040 (2)	0.038 (Left OD Coil) 0.040 (Right OD Coil)	0.040 (2)	0.049 (2)
(mm)	.81	.97	1.02	.97/102	1.02	1.24
OUTDOOR COIL Rows... Fins/in. face area (sq. ft.)	2...21 13.6	2...21 15.4	2...21 13.6	2...21 19.4	2...21 19.4	2...21 23.3
OUTDOOR FAN Nominal Airflow (CFM) Diameter Motor HP (RPM)	2500 22 1/8 (825)	2600 22 1/8 (825)	3000 22 1/4 (1100)	3500 22 1/8 (825)	3500 22 1/4 (1100)	3800 22 1/3 (1100)
INDOOR COIL Rows... Fins/in. face area (sq. ft.)	3...17 3.7	3...17 3.7	3...17 4.7	3...17 4.7	3...17 5.7	4...17 5.7
INDOOR BLOWER Nominal Cooling Airflow (CFM) Size (in.) (mm) Motor (HP)	800 10x10 254x254 1/2	1000 10x10 254x254 1/2	1200 11x10 279x254 3/4	1400 11x10 279x254 3/4	1600 11x10 279x254 1.0	1750 11x10 279x254 1.0
HIGH-PRESSURE SWITCH (psig) Cutout Reset (Auto)	650±15 420±25					
LOSS-OF-CHARGE/LOW-PRESSURE SWITCH (Liquid Line) (psig) Cutout Reset (Auto)	20±5 45±10 20±5 45±10					
RETURN-AIR FILTERS*† throwaway (in.) (mm)	20x20x1 508x508x25	20x24x1 508x610x25	24x30x1 610x762x25		24x36x1 610x914x25	

*Required filter sizes shown are based on the larger of the ARI (Air conditioning and Refrigeration Institute) rated cooling airflow or the heating airflow velocity of 300 ft/minute for throwaway type or 450 ft/minute for high-capacity type. Air filter pressure drop for non-standard filters must not exceed 0.08 IN. W.C.

† If using accessory filter rack refer to the filter rack installation instructions for correct filter size and quantity.

‡ For 460 volt units, add 14 lb (6.4 kg) to the weight.

Table 2 – Minimum Airflow for Reliable Electric Heater Operation (CFM)

SIZE	607C024	607C030	607C036	607C042	607C048	607C060
AIRFLOW (CFM)	800	1025	1250	1400	1710	1800

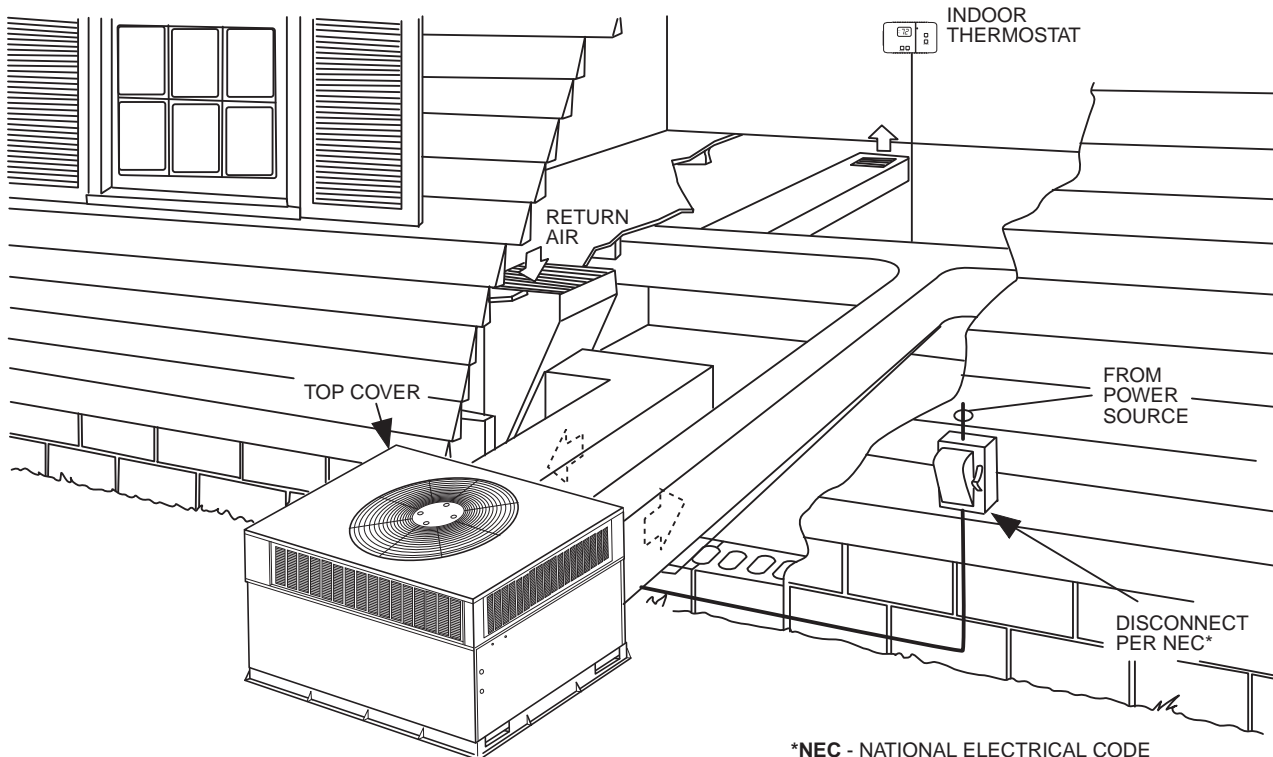

Fig. 9 - Typical Installation (Shown with optional louvers)

C00063

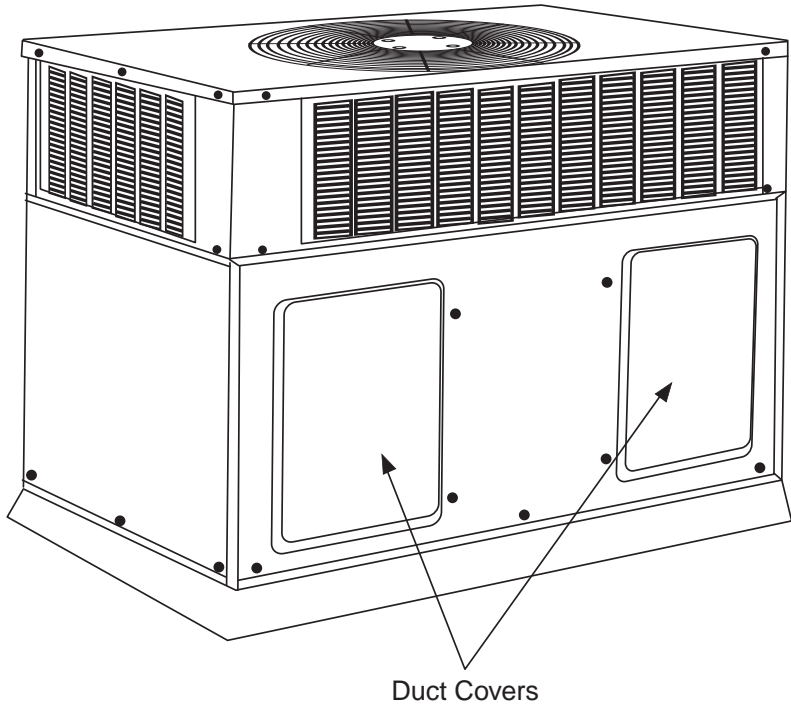

Fig. 10 - 607C with Duct Covers On (Shown with optional louvers)

C00092

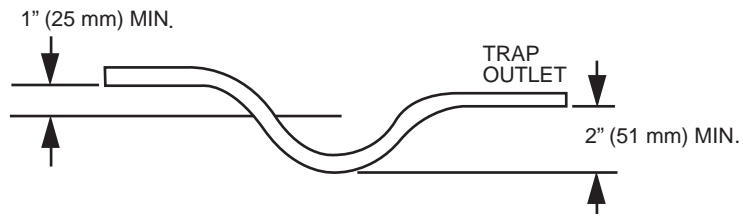

Fig. 11 - Condensate Trap

A08001

WARNING

FIRE, EXPLOSION, ELECTRICAL SHOCK HAZARD

Failure to follow this warning could result in personal injury, death or property damage.

1. Follow recognized safety practices and wear protective goggles when checking or servicing refrigerant system.
2. Relieve and recover all refrigerant from system before touching or disturbing compressor plug if refrigerant leak is suspected around compressor terminals.
3. Do not remove compressor plug until all electrical sources are disconnected and tagged.
4. Never attempt to repair soldered connection while refrigerant system is under pressure.
5. Do not use torch to remove any component. System contains oil and refrigerant under pressure. To remove a component, wear protective goggles and proceed as follows:
 - a. Shut off electrical power to unit and install lockout tag.
 - b. Relieve and reclaim all refrigerant from system using both high- and low-pressure ports.
 - c. Cut component connecting tubing with tubing cutter and remove component from unit.
 - d. Carefully unsweat remaining tubing stubs when necessary. Oil can ignite when exposed to torch flame.

Use the Start-Up Checklist supplied at the end of this book and proceed as follows to inspect and prepare the unit for initial start-up:

1. Remove all access panels.
2. Read and follow instructions on all DANGER, WARNING, CAUTION, and INFORMATION labels attached to, or shipped with, unit.
3. Make the following inspections:
 - a. Inspect for shipping and handling damages such as broken lines, loose parts, disconnected wires, etc.
 - b. Inspect for oil at all refrigerant tubing connections and on unit base. Detecting oil generally indicates a refrigerant leak. Leak-test all refrigerant tubing connections using electronic leak detector, or liquid-soap solution. If a refrigerant leak is detected, see following Check for Refrigerant Leaks section.
 - c. Inspect all field and factory-wiring connections. Be sure that connections are completed and tight. Ensure wires do not touch refrigerant tubing or sharp sheet metal edges.
 - d. Inspect coil fins. If damaged during shipping and handling, carefully straighten fins with a fin comb.
4. Verify the following conditions:
 - a. Make sure that outdoor-fan blade is correctly positioned in fan orifice.
 - b. Make sure that air filter(s) is in place.
 - c. Make sure that condensate drain pan and trap are filled with water to ensure proper drainage.
 - d. Make sure that all tools and miscellaneous loose parts have been removed.
5. Each unit system has 2 Schrader-type ports, one low-side Schrader fitting located on the suction line, and one high-side Schrader fitting located on the compressor discharge line. Be sure that caps on the ports are tight.

Checking Cooling and Heating Control Operation

Start and check the unit for proper control operation as follows:

- (1.) Place room thermostat SYSTEM switch or MODE control in OFF position. Observe that blower motor starts when FAN mode is placed in FAN ON position and shuts down when FAN MODE switch is placed in AUTO position.
- (2.) Thermostat:
When the room temperature rises to a point that is slightly above the cooling control setting of the thermostat, the thermostat completes the circuit between thermostat terminal R to terminals Y, O and G. These completed circuits through the thermostat connect contactor coil (C) (through unit wire Y) and Indoor Fan board (through unit wire G) across the 24-v. secondary of transformer (TRAN).
- (3.) Place system switch or MODE control in HEAT position. Set control above room temperature. Observe that compressor, outdoor fan, and indoor blower motors start. Observe that heating cycle shuts down when control setting is satisfied.
- (4.) When using an automatic changeover room thermostat place both SYSTEM or MODE control and FAN mode switches in AUTO positions. Observe that unit operates in Cooling mode when temperature control is set to "call for Cooling" (below room temperature), and unit operates in Heating mode when temperature control is set to "call for Heating" (above room temperature).

NOTE: Once the compressor has started and then has stopped, it should not be started again until 5 minutes have elapsed. The defrost board has a built-in 5 minute delay between cycles. The 5 minute compressor delay also applies to heat pump heating mode.

Step 1 — Check for Refrigerant Leaks

Proceed as follows to locate and repair a refrigerant leak and to charge the unit:

1. Locate leak and make sure that refrigerant system pressure has been relieved and reclaimed from both high- and low-pressure ports.
2. Repair leak following Refrigerant Service procedures.

NOTE: Install a bi-flow filter drier whenever the system has been opened for repair.

3. Add a small charge of R-410A refrigerant vapor to system and leak-test unit.
4. Recover refrigerant from refrigerant system and evacuate to 500 microns if no additional leaks are not found.
5. Charge unit with Puron (R-410A) refrigerant, using an electronic scale. Refer to unit rating plate for required charge.

Step 2 — Start-Up Adjustments

Complete the required procedures given in the Pre-Start-Up section before starting the unit. Do not jumper any safety devices when operating the unit. Do not operate the unit in Cooling mode when the outdoor temperature is below 40°F (4°C) (unless accessory low-ambient kit is installed).

IMPORTANT: Three-phase, scroll compressors are direction oriented. Unit must be checked to ensure proper compressor 3-phase power lead orientation. If not corrected within 5 minutes, the internal protector will shut off the compressor. The 3-phase power leads to the unit must be reversed to correct rotation. When turning backwards, the difference between compressor suction and discharge pressures may be near zero.

Checking and Adjusting Refrigerant Charge

The refrigerant system is fully charged with Puron (R-410A) refrigerant and is tested and factory sealed.

NOTE: Adjustment of the refrigerant charge is not required unless the unit is suspected of not having the proper Puron (R-410A) charge.

A subcooling charging chart is attached to the outside of the service access panel. The chart includes the required liquid line temperature at given discharge line pressures and outdoor ambient temperatures.

An accurate thermocouple- or thermistor-type thermometer, and a gauge manifold are required when using the subcooling charging method for evaluating the unit charge. Do not use mercury or small dial-type thermometers because they are not adequate for this type of measurement.

NOTE: Allow system to operate for a minimum of 15 minutes before checking or adjusting refrigerant charge.

IMPORTANT: When evaluating the refrigerant charge, an indicated adjustment to the specified factory charge must always be very minimal. If a substantial adjustment is indicated, an abnormal condition exists somewhere in the cooling system, such as insufficient airflow across either coil or both coils.

Proceed as follows:

1. Remove caps from low- and high-pressure service fittings.
2. Using hoses with valve core depressors, attach low- and high-pressure gauge hoses to low- and high-pressure service fittings, respectively.
3. Start unit and let run until system pressures stabilize.
4. Measure and record the following:
 - a. Outdoor ambient-air temperature ($^{\circ}\text{F}$ [$^{\circ}\text{C}$] db).
 - b. Liquid line temperature ($^{\circ}\text{F}$ [$^{\circ}\text{C}$]) at TXV.
 - c. Discharge (high-side) pressure (psig).
 - d. Suction (low-side) pressure (psig) (for reference only).
5. Using Cooling Charging Charts compare outdoor-air temperature ($^{\circ}\text{F}$ [$^{\circ}\text{C}$] db) with the discharge line pressure (psig) to determine desired system operating liquid line temperature (See Fig. 19).
6. Compare actual liquid line temperature with desired liquid line temperature. Using a tolerance of $\pm 2^{\circ}\text{F}$ ($\pm 1.1^{\circ}\text{C}$), add refrigerant if actual temperature is more than 2°F (1.1°C) higher than proper liquid line temperature, or remove refrigerant if actual temperature is more than 2°F (1.1°C) lower than required liquid line temperature.

NOTE: If the problem causing the inaccurate readings is a refrigerant leak, refer to Check for Refrigerant Leaks section.

Indoor Airflow and Airflow Adjustments

All 607C blower motors are factory wired for nominal cooling airflow operation at minimum external static pressure. See Table 1.

NOTE: Be sure that all supply- and return-air grilles are open, free from obstructions, and adjusted properly.

Table 3 – Color Coding for Indoor Fan Motor Leads

Black = High Speed
Orange = Med-High Speed
Red = Med Speed
Pink = Med-Low Speed
Blue = Low Speed

⚠ WARNING

ELECTRICAL SHOCK HAZARD

Failure to follow this warning could result in personal injury or death.

Disconnect electrical power to the unit and install lockout tag before changing blower speed.

The fan speed of the unit is connected to the “HIGH” terminal on the interface fan board (IFB) (See Fig. 12-14 and 17). The unit is factory-shipped with a fan speed as noted in Table 4. There are 4 additional speed tap wires available for use (For color coding on the indoor fan motor leads, see Table 4). The additional 4 speed tap wires are shipped loose with vinyl caps and are located in the control box, near the IFB.

To change the fan speed, remove the vinyl cap off of the desired speed tap wire (Refer to Table 3 for color coding). Remove the current speed tap wire from the “HIGH” terminal on the interface fan board (IFB) (Fig. 17) and place vinyl cap over the connector on the wire. Connect the desired speed tap wire to the “HIGH” terminal on the IFB. For optimum performance, add the wet coil pressure drop in Table 5 to the system static to determine the correct cooling airflow speed in Table 4 that will deliver the nominal cooling airflow as listed in Table 1 for each size.

NOTE: For cooling operation, the recommended airflow is 350 to 450 CFM for each 12,000 Btuh of rated cooling capacity.

NOTE: If accessory electric heat is installed in the unit, the dry airflow must meet or exceed the minimum airflow specified in Table 2 for the specific size. Use Table 4 to determine dry airflow for a known external static pressure. Electric heat fan speed is the same as cooling fan speed.

Continuous Fan Operation

The continuous fan operates at the same fan speed as cooling operation.

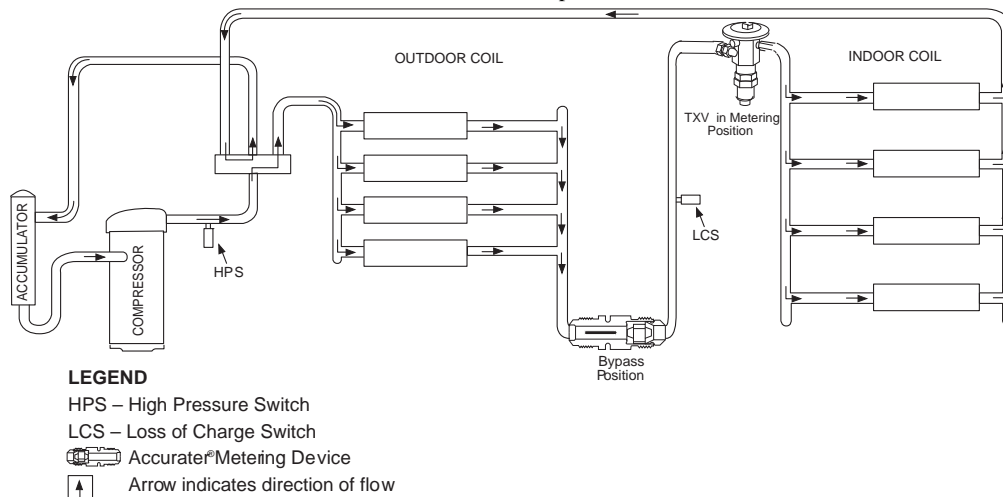

Fig. 15 - Typical Heat Pump Operation, Cooling Mode

C03011

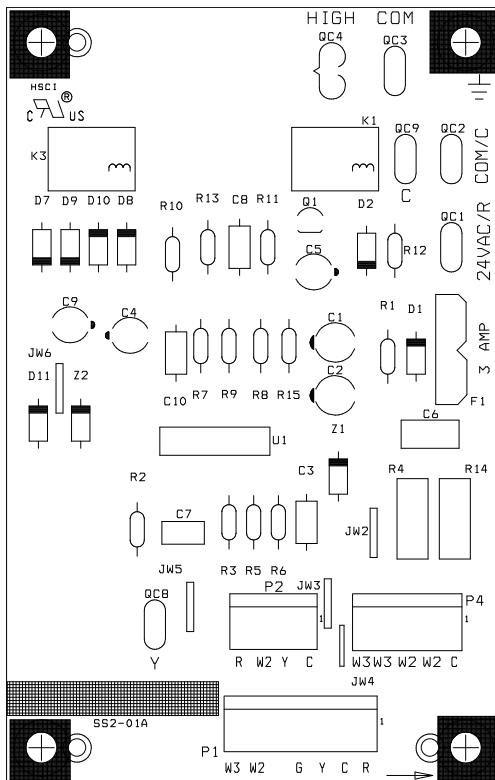

Fig. 16 - Interface Fan Board (IFB)

A07794

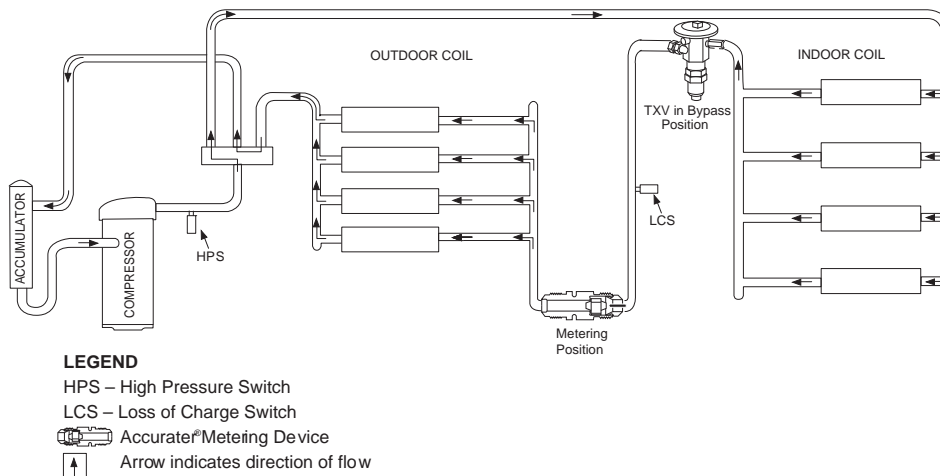

Fig. 17 - Typical Heat Pump Operation, Heating Mode

C03012

Step 3 — Defrost Control

Quiet Shift

Quiet Shift is a field-selectable defrost mode, which will eliminate occasional noise that could be heard at the start of defrost cycle and restarting of heating cycle. It is selected by placing DIP switch 3 (on defrost board) in ON position.

When Quiet Shift switch is placed in ON position, and a defrost is initiated, the following sequence of operation will occur. Reversing valve will energize, outdoor fan will turn off, compressor will turn off for 30 sec and then turn back on to complete defrost. At the start of heating after conclusion of defrost reversing valve will de-energize, compressor will turn off for another 30 sec, and the outdoor fan will stay off for 40 sec, before starting in the Heating mode.

Defrost

The defrost control is a time/temperature control which includes a field-selectable time period (DIP switch 1 and 2 on the board) between defrost cycles of 30, 60, 90, or 120 minutes (factory set at

60 minutes). To initiate a forced defrost, two options are available depending on the status of the defrost thermostat.

If defrost thermostat is closed, speed-up pins (J1) must be shorted by placing a flat head screw driver in between for 5 sec and releasing, to observe a complete defrost cycle. When the Quiet Shift switch is selected, compressor will be turned off for two 30 sec intervals during this complete defrost cycle, as explained previously. When Quiet Shift switch is in factory default OFF position, a normal and complete defrost cycle will be observed.

If defrost thermostat is in open position, and speedup pins are shorted (with a flat head screw driver) for 5 sec and released, a short defrost cycle will be observed (actual length is dependent upon the selected Quiet Shift position). When Quiet Shift switch is in ON position, the length of defrost is 1 minute (30 sec compressor off period followed by 30 sec of defrost with compressor operation). On return to heating operation, compressor will again turn off for an additional 30 sec and the outdoor fan for 40 sec. When the Quiet Shift is in OFF position, only a brief 30 sec. cycle will be observed.

NOTE: Unit will remain in defrost until defrost thermostat reopens at approximately 65°F (18°C) coil temperature at liquid line or remainder of defrost cycle time.

MAINTENANCE

To ensure continuing high performance, and to minimize the possibility of premature equipment failure, periodic maintenance must be performed on this equipment. This heat pump unit should be inspected at least once each year by a qualified service person. To troubleshoot unit, refer to Table 8.

NOTE: TO EQUIPMENT OWNER: Consult your local dealer about the availability of a maintenance contract.

⚠ WARNING

PERSONAL INJURY AND UNIT DAMAGE HAZARD

Failure to follow this warning could result in personal injury or death and unit component damage.

The ability to properly perform maintenance on this equipment requires certain expertise, mechanical skills, tools and equipment. If you do not possess these, do not attempt to perform any maintenance on this equipment, other than those procedures recommended in the Owner's Manual.

⚠ WARNING

ELECTRICAL SHOCK HAZARD

Failure to follow these warnings could result in personal injury or death:

1. Turn off electrical power to the unit and install a lockout tag before performing any maintenance or service on this unit.
2. Use extreme caution when removing panels and parts.
3. Never place anything combustible either on or in contact with the unit.

⚠ CAUTION

UNIT OPERATION HAZARD

Failure to follow this caution may result in improper operation.

Errors made when reconnecting wires may cause improper and dangerous operation. Label all wires prior to disconnecting when servicing.

The minimum maintenance requirements for this equipment are as follows:

1. Inspect air filter(s) each month. Clean or replace when necessary.
2. Inspect indoor coil, drain pan, and condensate drain each cooling season for cleanliness. Clean when necessary.
3. Inspect blower motor and wheel for cleanliness each cooling season. Clean when necessary.
4. Check electrical connections for tightness and controls for proper operation each cooling season. Service when necessary.

Step 1 — Air Filter

IMPORTANT: Never operate the unit without a suitable air filter in the return-air duct system. Always replace the filter with the same dimensional size and type as originally installed. See Table 1 for recommended filter sizes.

Inspect air filter(s) at least once each month and replace (throwaway-type) or clean (cleanable-type) at least twice during

each cooling season and twice during the heating season, or whenever the filter becomes clogged with dust and lint.

Indoor Blower and Motor

NOTE: All motors are pre-lubricated. Do not attempt to lubricate these motors.

NOTE: 460 volt units have a stepdown autotransformer that supplies approximately 230 volts to a nominal 230 volt indoor blower motor.

For longer life, operating economy, and continuing efficiency, clean accumulated dirt and grease from the blower wheel and motor annually.

⚠ WARNING

ELECTRICAL SHOCK HAZARD

Failure to follow this warning could result in personal injury or death.

Disconnect and tag electrical power to the unit before cleaning the blower motor and wheel.

To clean the blower motor and wheel:

1. Remove and disassemble blower assembly as follows:
 - a. Remove unit access panel.
 - b. Disconnect 5 pin plug and 4 pin plug from indoor blower motor.
 - c. On all units remove blower assembly from unit. Remove screws securing blower to blower partition and slide assembly out. Be careful not to tear insulation in blower compartment.
 - d. Ensure proper reassembly by marking blower wheel and motor in relation to blower housing before disassembly.
 - e. Loosen setscrew(s) that secures wheel to motor shaft, remove screws that secure motor mount brackets to housing, and slide motor and motor mount out of housing.
2. Remove and clean blower wheel as follows:
 - a. Ensure proper reassembly by marking wheel orientation.
 - b. Lift wheel from housing. When handling and/or cleaning blower wheel, be sure not to disturb balance weights (clips) on blower wheel vanes.
 - c. Remove caked-on dirt from wheel and housing with a brush. Remove lint and/or dirt accumulations from wheel and housing with vacuum cleaner, using soft brush attachment. Remove grease and oil with mild solvent.
 - d. Reassemble wheel into housing.
 - e. Reassemble motor into housing. Be sure setscrews are tightened on motor shaft flats and not on round part of shaft.
 - f. Connect 5 pin plug and 4 pin plug to indoor blower motor.
 - g. Reinstall unit access panel.
3. Restore electrical power to unit. Start unit and check for proper blower rotation and motor speeds during cooling cycles.

Table 4 – Dry Coil Air Delivery* - Horizontal and Downflow Discharge - Unit 607C024-060

Unit	Motor Speed	Wire Color		External Static Pressure (IN. W.C.)									
				0.1	0.2	0.3	0.4	0.5	0.6	0.7	0.8	0.9	
607C024	Low	Blue	CFM	741	638	547	415	---	---	---	---	---	---
	Med-Low ¹	Pink	CFM	898	820	738	662	536	---	---	---	---	---
	Medium	Red	CFM	973	887	823	733	665	538	451	---	---	---
	Med-High	Orange	CFM	1140	1064	996	915	840	758	687	564	480	---
607C030	High	Black	CFM	1202	1140	1082	1015	961	881	810	732	631	---
	Low	Blue	CFM	741	638	547	415	---	---	---	---	---	---
	Med-Low	Pink	CFM	898	820	738	662	536	---	---	---	---	---
	Medium	Red	CFM	973	887	823	733	665	538	451	---	---	---
607C036	Med-High ¹	Orange	CFM	1140	1064	996	915	840	758	687	564	480	---
	High ¹	Black	CFM	1202	1140	1082	1015	961	881	810	732	631	---
	Low	Blue	CFM	1295	1234	1182	1126	1075	1016	955	898	857	---
	Med-Low ¹	Pink	CFM	1345	1282	1235	1194	1140	1095	1027	974	921	---
607C042	Medium	Red	CFM	1505	1452	1413	1358	1323	1282	1234	1169	1130	---
	Med-High	Orange	CFM	1545	1492	1449	1411	1362	1313	1278	1231	1188	---
	High	Black	CFM	1705	1643	1607	1568	1518	1483	1448	1404	1360	---
	Low	Blue	CFM	1295	1234	1182	1126	1075	1016	955	898	857	---
607C048	Med-Low	Pink	CFM	1345	1282	1235	1194	1140	1095	1027	974	921	---
	Medium	Red	CFM	1505	1452	1413	1358	1323	1282	1234	1169	1130	---
	Med-High	Orange	CFM	1545	1492	1449	1411	1362	1313	1278	1231	1188	---
	High	Black	CFM	1705	1643	1607	1568	1518	1483	1448	1404	1360	---
607C060	Low	Blue	CFM	1445	1389	1341	1281	1236	1189	1139	1072	1027	---
	Med-Low ¹	Pink	CFM	1678	1635	1602	1558	1513	1474	1438	1404	1349	---
	Medium	Red	CFM	1962	1915	1880	1843	1794	1753	1711	1675	1628	---
	Med-High	Orange	CFM	2131	2088	2065	2013	1982	1941	1888	1860	1785	---
607C060	High	Black	CFM	2461	2409	2339	2286	2192	2140	2062	1968	1874	---
	Low	Blue	CFM	1448	1321	1282	1235	1192	1145	1101	1057	1011	---
	Med-Low	Pink	CFM	1722	1675	1614	1543	1499	1442	1408	1356	1308	---
	Medium ¹	Red	CFM	1887	1847	1783	1726	1677	1625	1578	1527	1432	---
607C060	Med-High	Orange	CFM	2055	2008	1958	1927	1900	1768	1685	1581	1458	---
	High	Black	CFM	2292	2238	2158	2049	1935	1840	1732	1635	1513	---

607C

* Air delivery values are without air filter and are for dry coil (See 607C Wet Coil Pressure Drop Table).

¹ Factory –shipped cooling/heat pump heating speed

NOTE: Deduct field –supplied air filter pressure drop and wet coil pressure drop to obtain external static pressure available for ducting.

Table 5 – 607C Wet Coil Pressure Drop (in. W.C.)

UNIT SIZE	STANDARD CFM (S.C.F.M)															
	500	600	700	800	900	1000	1100	1200	1300	1400	1500	1600	1700	1800	1900	2000
024		0.06	0.07	0.08	0.09	0.1										
030				0.12	0.15	0.19	0.23	0.27								
036						0.07	0.11	0.18	0.26	0.35						
042								0.04	0.07	0.1	0.15	0.21				
048										0.11	0.14	0.17	0.22	0.28		
060												0.1	0.17	0.23	0.31	0.36

Table 6 – Filter Pressure Drop Table (in. W.C.)

FILTER SIZE in. (mm)	CFM																		
	500	600	700	800	900	1000	1100	1200	1300	1400	1500	1600	1700	1800	1900	2000	2100	2200	2300
20X20X1 (508X508X25)	0.05	0.07	0.08	0.1	0.12	0.13	0.14	0.15	---	---	---	---	---	---	---	---	---	---	---
20X24X1 (508X610x25)	---	---	---	.09	.10	.11	.13	.14	.15	.16	---	---	---	---	---	---	---	---	---
24X30X1 (610X762x25)	---	---	---	0.04	0.05	0.06	0.07	0.07	0.08	0.09	0.1	---	---	---	---	---	---	---	---
24X36X1 (610X914X25)	---	---	---	---	---	---	---	0.06	0.07	0.07	0.08	0.09	0.09	0.10	0.11	0.12	0.13	0.14	0.14

Table 7 – Electric Heat Pressure Drop Table

Small Cabinet: 024-036 cfm

	500	600	700	800	900	1000	1100	1200	1300	1400	1500	1600
5kw	0.00	0.00	0.00	0.00	0.00	0.00	0.00	0.00	0.02	0.04	0.06	0.07
7.5 kw	0.00	0.00	0.00	0.00	0.00	0.00	0.00	0.02	0.03	0.05	0.07	0.08
10 kw	0.00	0.00	0.00	0.00	0.00	0.00	0.02	0.04	0.06	0.07	0.09	0.10
15 kw	0.00	0.00	0.00	0.02	0.04	0.06	0.08	0.10	0.12	0.14	0.16	0.18
20 kw	0.00	0.00	0.02	0.04	0.06	0.08	0.09	0.11	0.13	0.15	0.17	0.19

Electric Heat Pressure Drop Table (in. W.C.)

Large Cabinet 042-060 cfm

	1100	1200	1300	1400	1500	1600	1700	1800	1900	2000	2100	2200	2300	2400	2500
5kw	0.00	0.00	0.00	0.01	0.02	0.03	0.04	0.05	0.06	0.07	0.08	0.09	0.10	0.11	0.12
7.5 kw	0.00	0.00	0.01	0.02	0.03	0.04	0.05	0.06	0.07	0.08	0.09	0.10	0.11	0.12	0.13
10 kw	0.00	0.00	0.01	0.02	0.03	0.04	0.05	0.06	0.07	0.08	0.09	0.10	0.11	0.12	0.13
15 kw	0.00	0.02	0.03	0.04	0.05	0.06	0.07	0.08	0.09	0.10	0.11	0.12	0.13	0.14	0.15
20 kw	0.02	0.03	0.04	0.05	0.06	0.07	0.08	0.09	0.10	0.11	0.12	0.13	0.14	0.15	0.16

Step 2 — Outdoor Coil, Indoor Coil, and Condensate Drain Pan

Inspect the condenser coil, evaporator coil, and condensate drain pan at least once each year.

The coils are easily cleaned when dry; therefore, inspect and clean the coils either before or after each cooling season. Remove all obstructions, including weeds and shrubs, that interfere with the airflow through the condenser coil.

Straighten bent fins with a fin comb. If coated with dirt or lint, clean the coils with a vacuum cleaner, using the soft brush attachment. Be careful not to bend the fins. If coated with oil or grease, clean the coils with a mild detergent-and-water solution.

Rinse coils with clear water, using a garden hose. Be careful not to splash water on motors, insulation, wiring, or air filter(s). For best results, spray condenser coil fins from inside to outside the unit. On units with an outer and inner condenser coil, be sure to clean between the coils. Be sure to flush all dirt and debris from the unit base.

Inspect the drain pan and condensate drain line when inspecting the coils. Clean the drain pan and condensate drain by removing all foreign matter from the pan. Flush the pan and drain trough with clear water. Do not splash water on the insulation, motor, wiring, or air filter(s). If the drain trough is restricted, clear it with a plumbers snake or similar probe device.

607C

REQUIRED SUBCOOLING °F(°C)						Required Liquid Line Temperature for a Specific Subcooling (R-410A)													
Model Size	Outdoor Ambient Temperature °F(°C)					Pressure (psig)	Required Subcooling (°F)					Pressure (kPa)	Required Subcooling (°C)						
	75 (24)	85 (29)	95 (35)	105 (41)	115 (46)		5	10	15	20	25		3	6	8	11	14		
024	12 (6.7)	12 (6.7)	12 (6.7)	11 (6.1)	11 (6.1)	189	66	61	56	51	46	41	1303	19	16	13	11	8	5
030	16 (8.9)	15 (8.3)	15 (8.3)	15 (8.3)	14 (7.8)	196	68	63	58	53	48	43	1351	20	17	15	12	9	6
036	16 (8.9)	15 (8.3)	14 (7.8)	14 (7.8)	13 (7.2)	203	71	66	61	56	51	46	1399	21	19	16	13	10	8
042	14 (7.8)	14 (7.8)	13 (7.2)	13 (7.2)	13 (7.2)	210	73	68	63	58	53	48	1448	23	20	17	14	11	9
048	18 (10)	17 (9.4)	17 (9.4)	17 (9.4)	17 (9.4)	217	75	70	65	60	55	50	1496	24	21	18	15	13	10
060	15 (8.3)	15 (8.3)	14 (7.8)	14 (7.8)	14 (7.8)	224	77	72	67	62	57	52	1544	25	22	19	16	14	11
						231	79	74	69	64	59	54	1593	26	23	20	18	15	12
						238	81	76	71	66	61	56	1641	27	24	21	19	16	13
						245	82	77	72	67	62	57	1689	28	25	22	20	17	14
						252	84	79	74	69	64	59	1737	29	26	23	21	18	15
						260	86	81	76	71	66	61	1792	30	27	25	22	19	16
						268	88	83	78	73	68	63	1848	31	29	26	23	20	17
						276	90	85	80	75	70	65	1903	32	30	27	24	21	19
						284	92	87	82	77	72	67	1958	33	31	28	25	22	20
						292	94	89	84	79	74	69	2013	35	32	29	26	23	21
						300	96	91	86	81	76	71	2068	36	33	30	27	24	22
						309	98	93	88	83	78	73	2130	37	34	31	28	26	23
						318	100	95	90	85	80	75	2192	38	35	32	29	27	24
						327	102	97	92	87	82	77	2254	39	36	33	31	28	25
						336	104	99	94	89	84	79	2316	40	37	34	32	29	26
						345	106	101	96	91	86	81	2378	41	38	35	33	30	27
						354	108	103	98	93	88	83	2440	42	39	36	34	31	28
						364	110	105	100	95	90	85	2509	43	40	38	35	32	29
						374	112	107	102	97	92	87	2578	44	41	39	36	33	30
						384	113	108	103	98	93	88	2647	45	42	40	37	34	31
						394	115	110	105	100	95	90	2716	46	44	41	38	35	32
						404	117	112	107	102	97	92	2785	47	45	42	39	36	33
						414	119	114	109	104	99	94	2854	48	46	43	40	37	34
						424	121	116	111	106	101	96	2923	49	47	44	41	38	35
						434	123	118	113	108	103	98	2992	50	48	45	42	39	36
						444	124	119	114	109	104	99	3061	51	48	46	43	40	37
						454	126	121	116	111	106	101	3130	52	49	47	44	41	38
						464	128	123	118	113	108	103	3199	53	50	48	45	42	39
						474	129	124	119	114	109	104	3268	54	51	48	46	43	40
						484	131	126	121	116	111	106	3337	55	52	49	47	44	41
						494	132	127	122	117	112	107	3406	56	53	50	47	45	42
						504	134	129	124	119	114	109	3475	57	54	51	48	46	43
						514	136	131	126	121	116	111	3544	58	55	52	49	46	44
						524	137	132	127	122	117	112	3612	58	56	53	50	47	45
						534	139	134	129	124	119	114	3681	59	56	54	51	48	45

50VT500173 REV 3.0

Fig. 18 - Cooling Charging Table-Subcooling

A08076

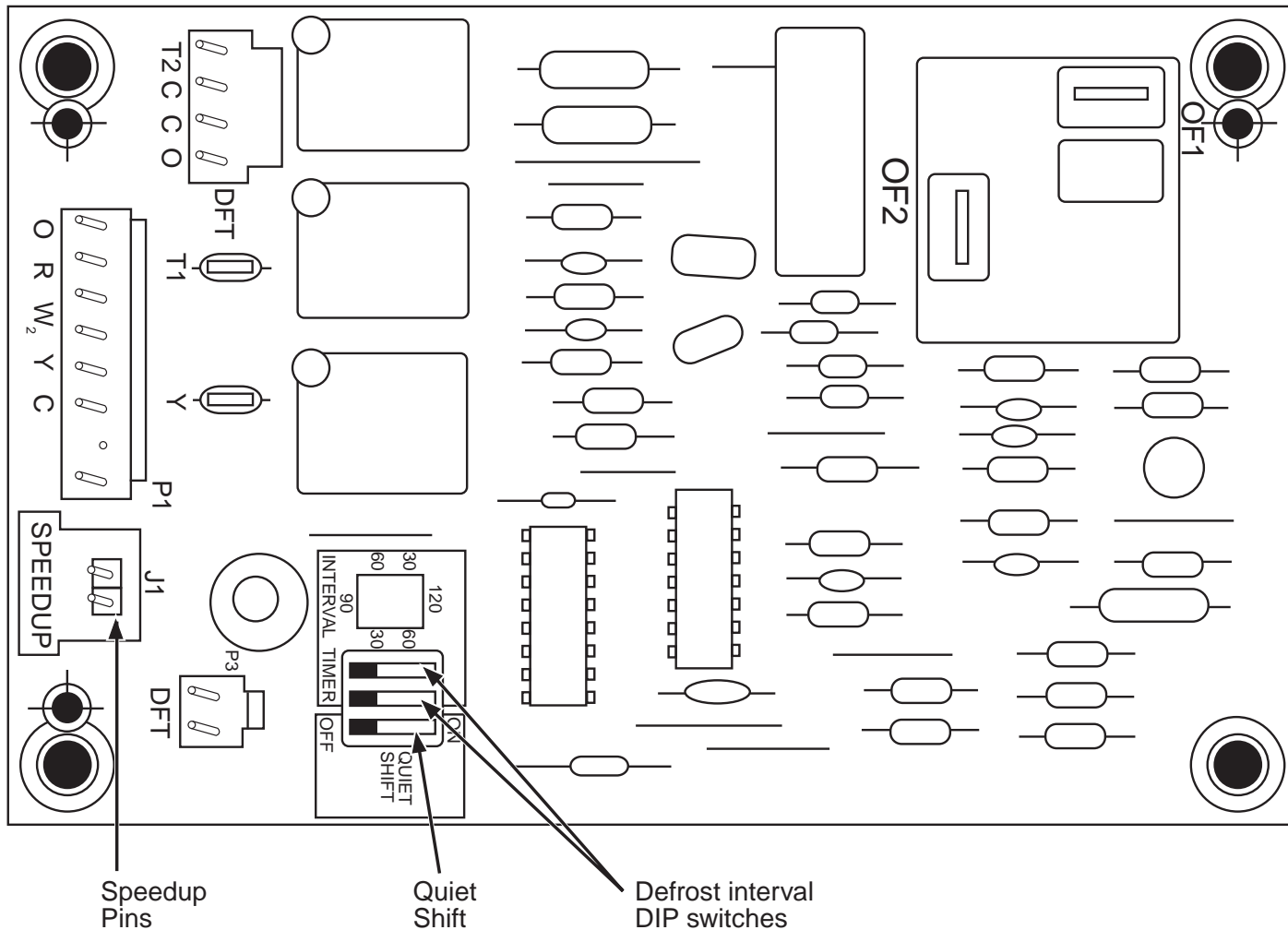

Fig. 19 - Defrost Control

A08020

Step 3 — Outdoor Fan

Keep the condenser fan free from all obstructions to ensure proper cooling operation. Never place articles on top of the unit. Damage to unit may result.

1. Remove 6 screws holding outdoor grille and motor to top cover.
2. Turn motor/grille assembly upside down on top cover to expose fan blade.
3. Inspect the fan blades for cracks or bends.
4. If fan needs to be removed, loosen setscrew and slide fan off motor shaft.
5. When replacing fan blade, position blade back to same position as before.
6. Ensure that setscrew engages the flat area on the motor shaft when tightening.
7. Replace grille.

Step 4 — Electrical Controls and Wiring

Inspect and check the electrical controls and wiring annually. Be sure to turn off the electrical power to the unit.

Remove access panel to locate all the electrical controls and wiring. Check all electrical connections for tightness. Tighten all screw connections. If any discolored or burned connections are noticed, disassemble the connection, clean all the parts, restrip the wire end and reassemble the connection properly and securely.

After inspecting the electrical controls and wiring, replace all the panels. Start the unit, and observe at least one complete cooling

cycle to ensure proper operation. If discrepancies are observed in operating cycle, or if a suspected malfunction has occurred, check each electrical component with the proper electrical instrumentation. Refer to the unit wiring label when making these checkouts.

Step 5 — Refrigerant Circuit

Inspect all refrigerant tubing connections and the unit base for oil accumulation annually. Detecting oil generally indicates a refrigerant leak.

If oil is detected or if low performance is suspected, leak-test all refrigerant tubing using an electronic leak detector, or liquid-soap solution. If a refrigerant leak is detected, refer to Check for Refrigerant Leaks section.

If no refrigerant leaks are found and low performance is suspected, refer to Checking and Adjusting Refrigerant Charge section.

Step 6 — Indoor Airflow

The heating and/or cooling airflow does not require checking unless improper performance is suspected. If a problem exists, be sure that all supply-air and return-air grilles are open and free from obstructions, and that the air filter is clean. When necessary, refer to Indoor Airflow and Airflow Adjustments section to check the system airflow.

Step 7 — Metering Devices-TXV & Piston

This unit uses 2 types of metering devices. The outdoor metering device is a fixed orifice and is contained in the brass hex-body in each liquid line feeding the outdoor coils. The indoor metering device is a TXV type device.

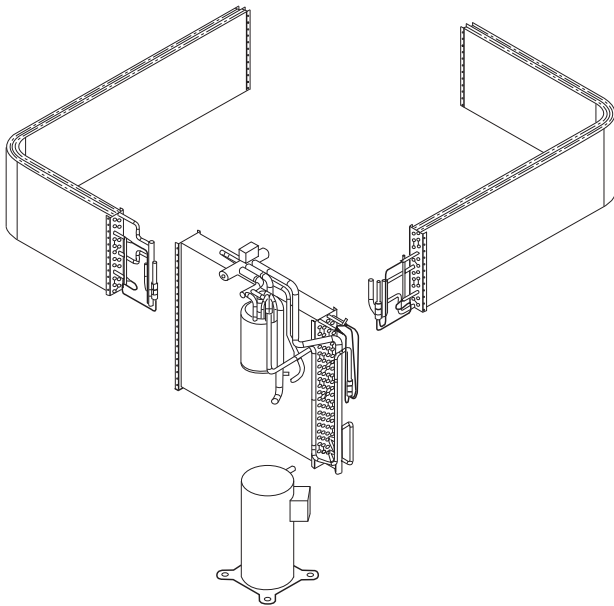

Fig. 20 - Refrigerant Circuit

C99097

Step 8 — Pressure Switches

Pressure switches are protective devices wired into control circuit (low voltage). They shut off compressor if abnormally high or low pressures are present in the refrigeration circuit. These pressure switches are specifically designed to operate with Puron (R-410A) systems. R-22 pressure switches must not be used as replacements for the Puron (R-410A) system.

Step 9 — Loss of Charge Switch

This switch is located on the liquid line and protects against low suction pressures caused by such events as loss of charge, low airflow across indoor coil, dirty filters, etc. It opens on a pressure drop at about 20 psig. If system pressure is above this, switch should be closed. To check switch:

1. Turn off all power to unit.
2. Disconnect leads on switch.
3. Apply ohm meter leads across switch. You should have continuity on a good switch.

NOTE: Because these switches are attached to refrigeration system under pressure, it is not advisable to remove this device for troubleshooting unless you are reasonably certain that a problem exists. If switch must be removed, remove and recover all system charge so that pressure gauges read 0 psi. Never open system without breaking vacuum with dry nitrogen.

Step 10 — High-Pressure Switch

The high-pressure switch is located in the discharge line and protects against excessive condenser coil pressure. It opens at 650 psig.

High pressure may be caused by a dirty outdoor coil, failed fan motor, or outdoor air recirculation.

To check switch:

1. Turn off all power to unit.
2. Disconnect leads on switch.
3. Apply ohm meter leads across switch. You should have continuity on a good switch.

Step 11 — Copeland Scroll Compressor (Puron Refrigerant)

The compressor used in this product is specifically designed to operate with Puron (R-410A) refrigerant and cannot be interchanged.

⚠ WARNING

EXPLOSION HAZARD

Failure to follow this warning could result in personal injury, death or property damage.

Wear safety glasses and gloves when handling refrigerants. Keep torches and other ignition sources away from refrigerant and oils.

The scroll compressor pumps refrigerant throughout the system by the interaction of a stationary and an orbiting scroll. The scroll compressor has no dynamic suction or discharge valves, and it is more tolerant of stresses caused by debris, liquid slugging, and flooded starts. The compressor is equipped with an internal pressure relief port. The pressure relief port is a safety device, designed to protect against extreme high pressure. The relief port has an operating range between 550 and 625 psi differential pressure.

The Copeland scroll compressor uses Mobil 3MAF POE oil. Copeland Ultra 22 CC should be used if additional oil is needed in the field. Mobil Artic EAL22CC or ICI Emkarate RL22 or 32CF oil may be used to recharge these compressors if Ultra 22 is not available.

Step 12 — Refrigerant System

This step covers the refrigerant system of the 607C, including the compressor oil needed, servicing systems on roofs containing synthetic materials, the filter drier and refrigerant charging.

Refrigerant

⚠ WARNING

PROPERTY HAZARD, PERSONAL INJURY OR ENVIRONMENTAL HAZARD

Failure to follow this warning could result in property damage or personal injury or death.

This system uses Puron (R-410A) refrigerant which has higher operating pressures than R-22 and other refrigerants. No other refrigerant may be used in this system. Gauge set, hoses, and recovery system must be designed to handle Puron. If you are unsure consult the equipment manufacturer.

Compressor Oil

The compressor in this system uses a polyolester (POE) oil, Mobil 3MAF POE. This oil is extremely hygroscopic, meaning it absorbs water readily. POE oils can absorb 15 times as much water as other oils designed for HCFC and CFC refrigerants. Take all necessary precautions to avoid exposure of the oil to the atmosphere.

Servicing Systems on Roofs with Synthetic Materials

POE (polyolester) compressor lubricants are known to cause long term damage to some synthetic roofing materials. Exposure, even if immediately cleaned up, may cause embrittlement (leading to cracking) to occur in one year or more. When performing any service that may risk exposure of compressor oil to the roof, take appropriate precautions to protect roofing. Procedures which risk oil leakage include, but are not limited to, compressor replacement, repairing refrigerant leaks, replacing refrigerant components such as filter drier, pressure switch, metering device, coil, accumulator, or reversing valve.

Synthetic Roof Precautionary Procedure

1. Cover extended roof working area with an impermeable polyethylene (plastic) drip cloth or tarp. Cover an approximate 10x10 ft (3x3 m) area.

2. Cover area in front of the unit service panel with a terry cloth shop towel to absorb lubricant spills and prevent run-offs, and protect drop cloth from tears caused by tools or components.
3. Place terry cloth shop towel inside unit immediately under component(s) to be serviced and prevent lubricant run-offs through the louvered openings in the unit base.
4. Perform required service.
5. Remove and dispose of any oil contaminated material per local codes.

Liquid Line Filter Drier

The biflow filter drier is specifically designed to operate with Puron. Use only factory-authorized components. Filter drier must be replaced whenever the refrigerant system is opened. When removing a filter drier, use a tubing cutter to cut the drier from the system. Do not unsweat a filter drier from the system. Heat from unsweating will release moisture and contaminants from drier into system.

Puron (R-410A) Refrigerant Charging

Refer to unit information plate and charging chart. Some R-410A refrigerant cylinders contain a dip tube to allow liquid refrigerant to flow from cylinder in upright position. For cylinders equipped with a dip tube, charge Puron units with cylinder in upright position and a commercial metering device in manifold hose. Charge refrigerant into suction-line.

Step 13 — System Information

Loss of Charge Switch

The loss of charge switch is a protective device wired into control circuit (low voltage). It shuts off the compressor if abnormally low pressures are present in the refrigeration circuit.

NOTE: Because these switches are attached to refrigeration system under pressure, it is not advisable to remove this device for troubleshooting unless you are reasonably certain that a problem exists. If switch must be removed, remove and recover all system charge so that pressure gauges read 0 psi. Never open system without breaking vacuum with dry nitrogen.

Check Defrost Thermostat

There is a liquid header with a brass distributor and feeder tube going into outdoor coil. At the end of 1 of the feeder tubes, there is a 3/8-in. OD stub tube approximately 3 in. (76 mm) long. (See Fig. 22). The defrost thermostat should be located on stub tube. Note that there is only 1 stub tube used with liquid header, and on most units it is the bottom circuit.

The defrost thermostat signals heat pump that conditions are right for defrost or that conditions have changed to terminate defrost. It is a thermally actuated switch clamped to outdoor coil to sense its temperature. Normal temperature range is closed at $32^{\circ} \pm 3^{\circ}\text{F}$ ($0 \pm 1.7^{\circ}\text{C}$) and open at $65^{\circ} \pm 5^{\circ}\text{F}$ ($18 \pm 2.8^{\circ}\text{C}$).

NOTE: The defrost thermostat must be located on the liquid side of the outdoor coil on the bottom circuit and as close to the coil as possible.

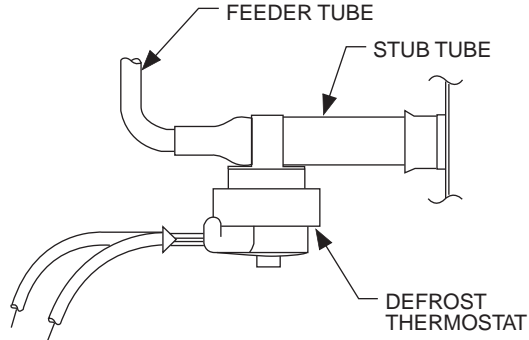

C99029

Fig. 21 - Defrost Thermostat

TROUBLESHOOTING

Refer to the Cooling and Heating Troubleshooting Chart (Table 8) for troubleshooting information.

START-UP CHECKLIST

Use the Start-Up Checklist.

PURON® (R-410A) QUICK REFERENCE GUIDE

- Puron refrigerant operates at 50-70 percent higher pressures than R-22. Be sure that servicing equipment and replacement components are designed to operate with Puron
- Puron refrigerant cylinders are rose colored.
- Recovery cylinder service pressure rating must be 400 psig, DOT 4BA400 or DOT BW400.
- Puron systems should be charged with liquid refrigerant. Use a commercial type metering device in the manifold hose when charging into suction line with compressor operating
- Manifold sets should be 700 psig high side and 180 psig low side with 550 psig low-side retard.
- Use hoses with 700 psig service pressure rating.
- Leak detectors should be designed to detect HFC refrigerant.
- Puron, as with other HFCs, is only compatible with POE oils.
- Vacuum pumps will not remove moisture from oil.
- Do not use liquid-line filter driers with rated working pressures less than 600 psig.
- Do not leave Puron suction line filter driers in line longer than 72 hours.
- Do not install a suction-line filter drier in liquid line.
- POE oils absorb moisture rapidly. Do not expose oil to atmosphere.
- POE oils may cause damage to certain plastics and roofing materials.
- Wrap all filter driers and service valves with wet cloth when brazing.
- A factory approved liquid-line filter drier is required on every unit.
- Do NOT use an R-22 TXV.
- If indoor unit is equipped with an R-22 TXV or piston metering device, it must be changed to a hard shutoff Puron TXV.
- Never open system to atmosphere while it is under a vacuum.
- When system must be opened for service, recover refrigerant, evacuate then break vacuum with dry nitrogen and replace filter driers. Evacuate to 500 microns prior to recharging.
- Do not vent Puron into the atmosphere.
- Do not use capillary tube coils.
- Observe all **warnings**, **cautions**, and **bold** text.
- All indoor coils must be installed with a hard shutoff Puron TXV metering device.

Table 8 – Troubleshooting Chart

SYMPTOM	CAUSE	REMEDY
Compressor and condenser fan will not start.	Power failure	Call power company
	Fuse blown or circuit breaker tripped	Replace fuse or reset circuit breaker
	Defective contactor, transformer, or high-pressure, loss-of-charge or low-pressure switch	Replace component
	Insufficient line voltage	Determine cause and correct
	Incorrect or faulty wiring	Check wiring diagram and rewire correctly
	Thermostat setting too high	Lower thermostat setting below room temperature
Compressor will not start but condenser fan runs	Faulty wiring or loose connections in compressor circuit	Check wiring and repair or replace
	Compressor motor burned out, seized, or internal overload open	Determine cause Replace compressor
	Defective run/start capacitor, overload, start relay	Determine cause and replace
	One leg of 3-phase power dead	Replace fuse or reset circuit breaker Determine cause
Three-phase scroll compressor makes excessive noise, and there may be a low pressure differential.	Scroll compressor is rotating in the wrong direction	Correct the direction of rotation by reversing the 3-phase power leads to the unit.
Compressor cycles (other than normally satisfying thermostat).	Refrigerant overcharge or undercharge	Recover refrigerant, evacuate system, and recharge to capacities shown on rating plate
	Defective compressor	Replace and determine cause
	Insufficient line voltage	Determine cause and correct
	Blocked condenser	Determine cause and correct
	Defective run/start capacitor, overload or start relay	Determine cause and replace
	Defective thermostat	Replace thermostat
	Faulty condenser-fan motor or capacitor	Replace
	Restriction in refrigerant system	Locate restriction and remove
Compressor operates continuously	Dirty air filter	Replace filter
	Unit undersized for load	Decrease load or increase unit size
	Thermostat set too low	Reset thermostat
	Low refrigerant charge	Locate leak, repair, and recharge
	Mechanical damage in compressor	Replace compressor
	Air in system	Recover refrigerant, evacuate system, and recharge
	Condenser coil dirty or restricted	Clean coil or remove restriction
Excessive head pressure	Dirty air filter	Replace filter
	Dirty condenser coil	Clean coil
	Refrigerant overcharged	Recover excess refrigerant
	Air in system	Recover refrigerant, evacuate system, and recharge
	Condenser air restricted or air short-cycling	Determine cause and correct
Head pressure too low	Low refrigerant charge	Check for leaks, repair, and recharge.
	Compressor IPR leaking	Replace compressor
	Restriction in liquid tube	Remove restriction
Excessive suction pressure	High heat load	Check for source and eliminate
	Compressor IPR leaking	Replace compressor
	Refrigerant overcharged	Recover excess refrigerant
Suction pressure too low	Dirty air filter	Replace filter
	Low refrigerant charge	Check for leaks, repair and recharge
	Metering device or low side restricted	Remove source of restriction
	Insufficient evaporator airflow	Increase air quantity Check filter—replace if necessary
	Temperature too low in conditioned area	Reset thermostat
	Outdoor ambient below 55°F (12.7°C)	Install low-ambient kit
	Filter drier restricted	Replace filter

607C

START-UP CHECKLIST
(Remove and Store in Job File)

I. Preliminary Information

MODEL NO.: _____
SERIAL NO.: _____
DATE: _____
TECHNICIAN: _____

II. PRE-START-UP (Insert checkmark in box as each item is completed)

- VERIFY THAT ALL PACKING MATERIALS HAVE BEEN REMOVED FROM UNIT
- REMOVE ALL SHIPPING HOLD DOWN BOLTS AND BRACKETS PER INSTALLATION INSTRUCTIONS
- CHECK ALL ELECTRICAL CONNECTIONS AND TERMINALS FOR TIGHTNESS
- CHECK THAT INDOOR (EVAPORATOR) AIR FILTER IS CLEAN AND IN PLACE
- VERIFY THAT UNIT INSTALLATION IS LEVEL
- CHECK FAN WHEEL, AND PROPELLER FOR LOCATION IN HOUSING/ORIFICE AND SETSCREW TIGHTNESS

III. START-UP

ELECTRICAL

SUPPLY VOLTAGE _____
COMPRESSOR AMPS _____
INDOOR (EVAPORATOR) FAN AMPS _____

TEMPERATURES

OUTDOOR (CONDENSER) AIR TEMPERATURE _____ DB
RETURN-AIR TEMPERATURE _____ DB _____ WB
COOLING SUPPLY AIR _____ DB _____ WB
HEAT PUMP SUPPLY AIR _____
ELECTRIC HEAT SUPPLY AIR _____

PRESSURES

REFRIGERANT SUCTION _____ PSIG SUCTION LINE TEMP* _____
REFRIGERANT DISCHARGE _____ PSIG DISCHARGE TEMP† _____
 VERIFY REFRIGERANT CHARGE USING CHARGING CHARTS

*Measured at suction inlet to compressor

†Measured at liquid line leaving condenser.

607C

A08187