

50VT-C

Comfort™ 14 SEER Single-Packaged Heat Pump System with Puron® (R-410A) Refrigerant  
Single Phase 2-5 Nominal Tons (Sizes 24-60)  
Three Phase 3-5 Nominal Tons (Sizes 36-60)

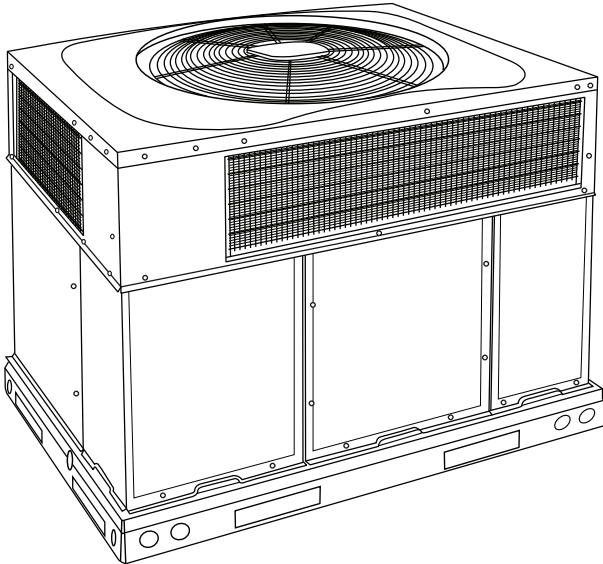

## Product Data



A170030

Fig. 1 - Unit 50VT-C

Single-Packaged Products with Energy-Saving Features and Puron® refrigerant.

- Up to 14.5 SEER
- Up to 12.0 EER
- 8.0 HSPF
- ECM Motor-Standard
- Dense Wire Condenser Coil Guard-Standard
- Cabinet air leakage of 2.0% or less at .5 in. W.C. when tested in accordance with ASHRAE standard 193. (Low leak FIOP models only.)

### FEATURES/BENEFITS

One-piece Heat Pump unit with optional electric heater, low installation cost, dependable performance and easy maintenance.

**Efficient operation High-efficiency design** with SEERs (Seasonal Energy Efficiency Ratio) of up to 14.5.

**Puron Environmentally Sound Refrigerant** is Carrier's unique refrigerant designed to be environmentally balanced. Puron is an HFC refrigerant which does not contain chlorine that can harm the ozone layer. Puron refrigerant is in service in millions of systems, proving highly reliable and is non-ozone depleting.

#### Easy Installation

Factory-assembled package is a compact, fully self-contained, heat pump unit that is prewired, pre-piped, and pre-charged for minimum installation expense. These units are available in a variety of standard capacity ranges with voltage options to meet residential and light commercial requirements. Units are lightweight and install easily on a rooftop or at ground level. The high tech composite base eliminates rust problems associated with ground level applications.

#### Durable, dependable components

**Scroll Compressors** are designed for high efficiency. Each compressor is hermetically sealed against contamination to help promote longer life and dependable operation. Each compressor also has vibration isolation to provide quieter operation. All compressors have internal high pressure and overcurrent protection.

**ECM Motor** is standard on all models. Direct-drive, PSC (Permanent Split Capacitor) condenser-fan motors are designed to help reduce energy consumption and provide for cooling operation down to 40°F (4.4°C) outdoor temperature. Motormaster® II low ambient kit is available as a field installed accessory.

#### Innovative Unit Base Design

On the inside a high-tech composite material will not rust and incorporates a sloped drain pan which improves drainage and helps inhibit mold, algae and bacterial growth. On the outside metal base rails provide added stability as well as easier handling and rigging.

**Thermostat Controls** designed to work as a system with Carrier's small packaged product.

**Refrigerant system** is designed to provide dependability. Liquid filter driers are used to promote clean, unrestricted operation. Each unit leaves the factory with a full refrigerant charge. Refrigerant service connections make checking operating pressures easier.

**High and Low Pressure Switches** provide added reliability for the compressor.

**Indoor and Outdoor coils** are computer-designed for optimum heat transfer and efficiency. The indoor coil is fabricated from copper tube and aluminum fins and is located inside the unit for protection against damage. The outdoor coil is internally mounted on the top tier of the unit.

**Low sound ratings** ensure a quiet indoor and outdoor environment with sound ratings as low as 73dBA.

**Easy to service cabinets** provide easy 3 panel accessibility to serviceable components during maintenance and installation. The base with integrated drain pan provides easy ground level installation with mounting pad. A nesting feature ensures a positive basepan to roof curb seal when the unit is roof mounted. A convenient 3/4-in. wide perimeter flange makes frame mounting on a rooftop easy.

#### Convertible duct configuration

Unit is designed for use in either downflow or horizontal applications. Each unit is converted from horizontal to downflow with the two standard duct covers. Downflow operation is easily provided in the field to allow vertical ductwork connections. The basepan utilizes seals on the bottom openings to ensure a positive seal in the vertical airflow mode.

**Cabinets** are constructed of heavyduty, phosphated, zinc-coated prepainted steel capable of withstanding 500 hours in salt spray. Interior surfaces of the evaporator and electric heater compartments are insulated with cleanable semi-rigid insulation board, which keeps the conditioned air from being affected by the outdoor ambient temperature and provides improved indoor air quality. (Conforms to American Society of Heating, Refrigeration and Air

Conditioning Engineers No. 62P.) The sloped drain pan minimizes standing water in the drain. An external drain is provided.

**Short-Cycling protection** for the compressor is incorporated into our defrost control board ensuring a five minute delay (+/-2 minutes) before restarting compressor after shutdown for any reason.

## TABLE OF CONTENTS

FEATURES/BENEFITS . . . . .	1
MODEL NUMBER NOMENCLATURE . . . . .	2
AHRI CAPACITIES . . . . .	3
PHYSICAL DATA . . . . .	4
OPTIONS AND ACCESSORIES . . . . .	5
ROOF CURB ACCESSORY DIMENSIONS . . . . .	6
BASE UNIT DIMENSIONS . . . . .	7-8
SELECTION PROCEDURE . . . . .	10
PERFORMANCE DATA . . . . .	11-24
TYPICAL PIPING AND WIRING . . . . .	25
APPLICATION DATA . . . . .	26
ELECTRICAL DATA . . . . .	28
TYPICAL WIRING SCHEMATICS . . . . .	30-35
CONTROLS . . . . .	36
GUIDE SPECIFICATIONS . . . . .	37-38

**50VT**

## MODEL NUMBER NOMENCLATURE

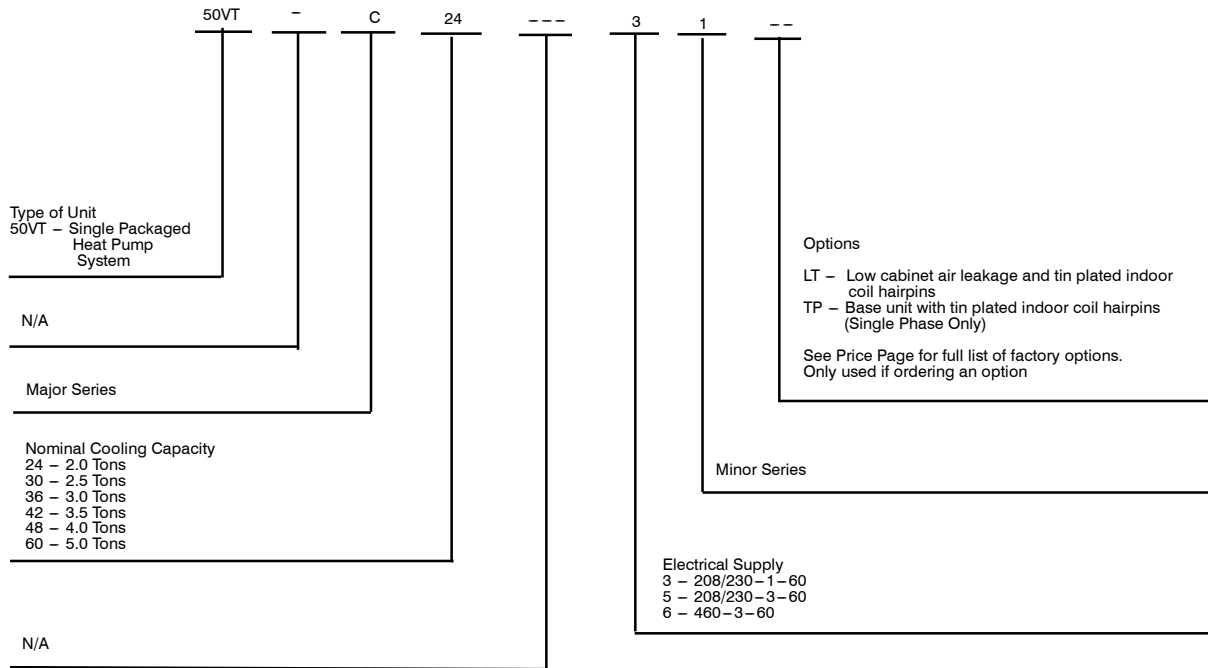

Use of the AHRI Certified TM Mark indicates a manufacturer's participation in the program. For verification of certification for individual products, go to [www.ahridirectory.org](http://www.ahridirectory.org).



**AHRI\* CAPACITIES**  
**COOLING CAPACITIES AND EFFICIENCIES**

UNIT	NOMINAL TONS	STANDARD CFM	COOLING CAPACITY	EER	SEER
24	2	800	23000	12.0	14.5
30	2.5	1000	28600	11.5	14.0
36	3	1200	34200	11.5	14.0
42	3.5	1400	41000	11.5	14.0
48	4	1600	48000	12.0	14.0
60	5	1750	57500	11.5	14.0

**HEAT PUMP HEATING CAPACITIES AND EFFICIENCIES**

UNIT	HEATING CAPACITY (BTUH) @ 47° F (8.3° C)	COP @ 47° F (8.3° C)	HEATING CAPACITY (BTUH) @ 17° F (-8.3° C)	COP @ 17° F (-8.3° C)	HSPF
24	22600	3.7	12000	2.30	8.0
30	28400	3.7	15600	2.35	8.0
36	34400	3.6	18600	2.30	8.0
42	40000	3.6	22600	2.40	8.0
48	46000	3.6	25800	2.40	8.0
60	57500	3.7	33000	2.45	8.0

**LEGEND**

**dB**—Sound Levels (decibels)

**db**—Dry Bulb

**SEER**—Seasonal Energy Efficiency Ratio

**wb**—Wet Bulb

**COP**—Coefficient of Performance

**HSPF**—Heating Season Performance Factor

\* Air Conditioning, Heating & Refrigeration Institute.

\*\*At "A" conditions—80°F (26.7°C) indoor db/67°F (19.4°C) indoor wb & 95°F (35°C) outdoor db.

† Rated in accordance with U.S. Government DOE Department of Energy) test procedures and/or AHRI Standards 210/240.

**Notes:**

1. Ratings are net values, reflecting the effects of circulating fan heat.

Ratings are based on:

**Cooling Standard:** 80°F (26.7°C) db, 67°F (19.4°C) wb indoor entering—air temperature and 95°F (35°C) db outdoor entering—air temperature.

2. Before purchasing this appliance, read important energy cost and efficiency information available from your retailer.

50VT

## PHYSICAL DATA

	24	30	36	42	48	60
Unit Size	2	2.5	3	3.5	4	5
Shipping Weight (lb) (kg)	365 166	395 179	440 200	475 215	500 227	515 234
Compressor Quantity	1					
Type	Scroll					
Refrigerant	R-410A					
Refrigerant Quantity (lb) Quantity (kg)	7.5 3.4	9.0 4.1	8.9 4.0	11.2 5.1	9.9 4.5	11.9 5.4
Refrigerant Metering Device	Indoor TXV, Outdoor Dual Accuraters				Indoor Accurater, Outdoor Dual Accuraters	Indoor TXV, Out- door Dual Accuraters
Orifice ID (in) (mm)	N/A				0.080 (1) 2.03 (1)	N/A
Orifice OD (in) (mm)	0.032 (2) 0.81 (2)	0.035 (2) 0.89 (2)	0.040 (2) 1.02 (2)	0.046 (2) 1.17 (2)	0.046 (2) 1.17 (2)	0.052 (2) 1.32 (2)
Outdoor Coil Rows...Fins/in, face area (sq. ft.)	1...21 15.4	1...21 18.8	1...21 17.5	1...21 23.3	1...21 23.3	2...21 17.5
Outdoor Fan Nominal Airflow (cfm) Diameter (in.) Diameter (mm) Motor hp (rpm)	2500 24 610 1/12 (810)	3000 24 610 1/10 (810)	3600 26 660 1/5 (810)	4000 26 660 1/5 (810)	4000 26 660 1/5 (810)	3800 26 660 1/4 (810)
Indoor Coil Rows...Fins/in, face area (sq. ft.)	3...17 3.7	3...17 3.7	2...15 5.6	3...17 4.7	3...17 4.7	3...17 5.6
Indoor Blower Nominal Airflow (cfm) Size (in.) Size (mm) Motor hp (rpm)	800 10 x 10 254 x 254 1/2	1000 10 x 10 254 x 254 1/2	1200 11 x 10 279 x 254 1/2	1350 11 x 10 279 x 254 1/2	1600 11 x 10 279 x 254 1	1750 11 x 10 279 x 254 1
High Pressure Switch (psig) Cutout Reset (Auto)	650 +/- 15 420 +/- 25					
Loss-of-Charge/Low Pressure Switch (psig) Cutout Reset (Auto)	20 +/- 5 45 +/- 10					
Return Air Filters disposable	2 each 20x12x1 in. 508x305x25 mm		1 each 24x16x1 in. 610x406x25 mm 24x18x1 in. 610x457x25 mm	1 each 24x14x1 in. 610x356x25 mm 24x16x1 in. 610x406x25 mm	1 each 24x16x1 in. 610x406x25 mm 24x18x1 in. 610x457x25 mm	

\*Required filter sizes shown are based on the larger of the AHRI (Air Conditioning Heating and Refrigeration Institute) rated cooling airflow or the heating airflow velocity of 300–350 ft/minute for throwaway type or 450 ft/minute for high–capacity type. Air filter pressure drop for non–standard filters must not exceed 0.08 IN. W.C.

† If using accessory filter rack refer to the filter rack installation instructions for correct filter size and quantity.

## A-WEIGHTED SOUND POWER LEVEL (dBA)

UNIT SIZE	STANDARD RATING (dBA)	TYPICAL OCTAVE BAND SPECTRUM (dBA without tone adjustment)						
		125	250	500	1000	2000	4000	8000
24	74	55.1	54.3	56.7	54.9	51.7	47.2	42.9
30	75	52.7	53.0	57.9	58.7	54.8	52.2	43.2
36	74	61.9	63.3	58.9	59.9	58.7	56.2	52.4
42	73	52.7	56.9	61.5	60.7	56.7	54.1	47.9
48	74	57.4	57.1	60.9	63.2	57.8	54.8	46.1
60	75	59.3	62.2	62.1	64.1	59.4	55.8	50.2

NOTE: Tested in accordance with AHRI Standard 270–1995 (not listed in AHRI).

## OPTIONS AND ACCESSORIES

ITEM	DESCRIPTION	FACTORY INSTALLED OPTION	FIELD INSTALLED ACCESSORY
Coil Options	Base unit with tin plated indoor coil hairpins	X	
Compressor Start Kit	Compressor Start Kit assists compressor start-up by providing additional starting torque on sing phase units only.		X
Corporate Thermostats	Thermostats provide control for the system heating and cooling functions.		X
Crankcase Heater	Crankcase Heater provides anti-floodback protection for low-load cooling applications.		X*
Economizer	Horizontal Economizer with solid state controls and barometric relief dampers includes filter racks and provide outdoor air during cooling and reduce compressor operation.		X
	Vertical Economizer with solid state controls and barometric relief dampers includes filter racks and provide outdoor air during cooling and reduce compressor operation.		X
Electric Heaters	Electric Heat Supplement		X
Filter Rack	Filter Rack features easy installation, serviceability, and high-filtering performance for vertical applications. Includes 1-in. filter.		X
Flat Roof Curb	14-in. (356 mm) Flat Roof Curb is available for roof mounted applications.		X
Low Ambient Kit	Low Ambient Kit (Motormaster II Control) allows the use of mechanical cooling down to outdoor temperatures as low as 0°F (-18°C) when properly installed.		X
Manual Outside Air Damper	Manual Outside Air Damper includes hood and filter rack with adjustable damper blade for up to 25% outdoor air.		X
Square-to-Round Duct Transition Kit	Square-to-Round Duct Transition Kit enable 24-48 size units to be fitted to 14 in. (356 mm) round ductwork.		X
Time Guard II	Automatically prevents the compressor from restarting for at least 4 minutes and 45 seconds after shutdown of the compressor. Not required when a corporate programmable thermostat is applied or with a RTU-MP control.		X*
Curb Adaptor	Adapter curb for new unit with base rail installed on existing curb		X
Gasket Kit	For field modified existing roof curb with new base rail unit.		X
Dual Point Electric Heaters	Allows you to power the electric heater and unit contactor separately by having two individual field power supply circuits connected respectively.		X
Low Cabinet Air Leakage	Cabinet air leakage of 2.0% or less at .5 in. W.C. when tested in accordance with ASHRAE standard 193.	X	
Louver Metal Outdoor Coil Grilles	Louver Metal Outdoor Coil Grilles provide hail and vandalism protection.		X

\*Refer to Price page for application detail.

### Electric Heaters

ORDERING NO.	NOMINAL CAPACITY (kW @ 240 or 480 VOLTS)	USED WITH SIZES					
		24	30	36	42	48	60
<b>208/230 - SINGLE PHASE - 60 HZ</b>							
CPHEATER052B0*	5.0	X	X	X			
CPHEATER064B0*	5.0	X	X	X	X	X	X
CPHEATER070B0*	7.2	X	X	X	X	X	X
CPHEATER050B0*	10.0	X	X	X	X	X	X
CPHEATER066B0*	15.0			X	X	X	X
CPHEATER133B0*	15.0		X				
CPHEATER054B0*	20.0				X	X	X
<b>208/230 - THREE PHASE - 60 HZ</b>							
CPHEATER055B0*	5.0			X	X	X	X
CPHEATER056B0*	10.0			X	X		
CPHEATER068B0*	10.0			X	X	X	X
CPHEATER058B0*	15.0			X	X	X	X
CPHEATER059B0*	20.0				X	X	X
<b>460 - THREE PHASE - 60 HZ</b>							
CPHEATER061B0*	10.0			X	X	X	X
CPHEATER062B0*	15.0			X	X	X	X
CPHEATER063B0*	20.0				X	X	X

**NOTE:** Electric heaters are rated at 240v. Refer to Multiplication Factors table for other voltages.

X = Approved combination

### Minimum Airflow for Reliable Electric Heater Operation (CFM)

SIZE	24	30	36	42	48	60
<b>AIRFLOW (CFM)</b>	800	1025	1250	1400	1710	1800

50VT

# ECONOMIZER

50VT

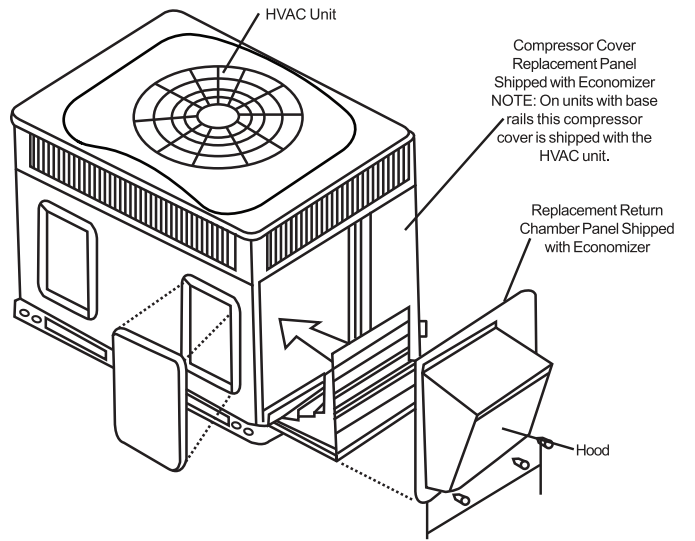
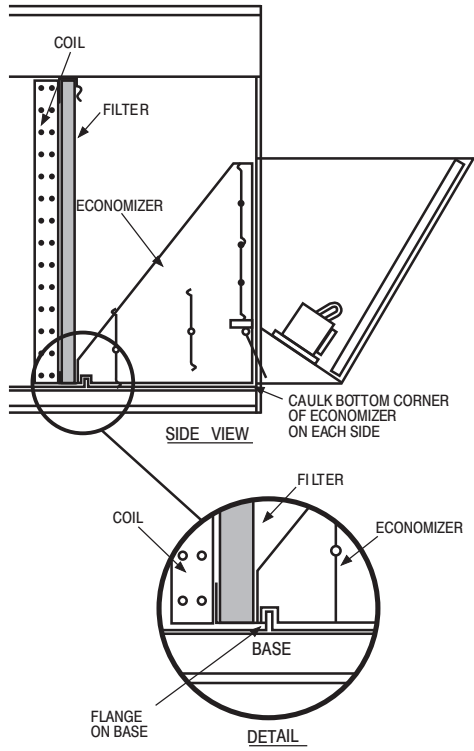

Vertical Economizer

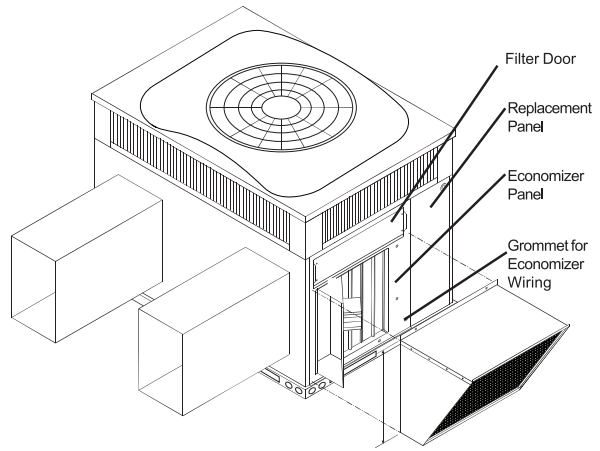

Horizontal Economizer

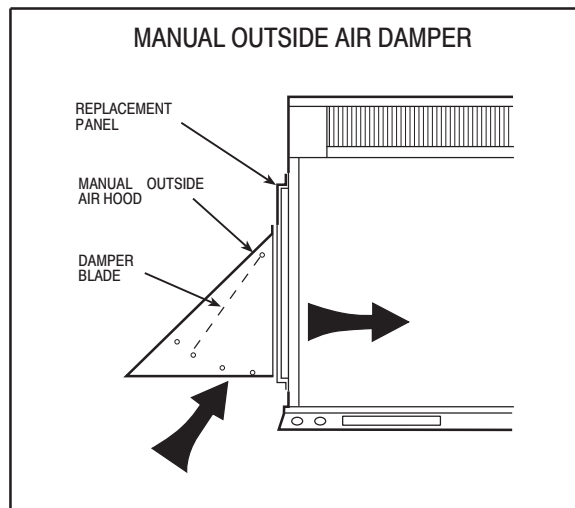
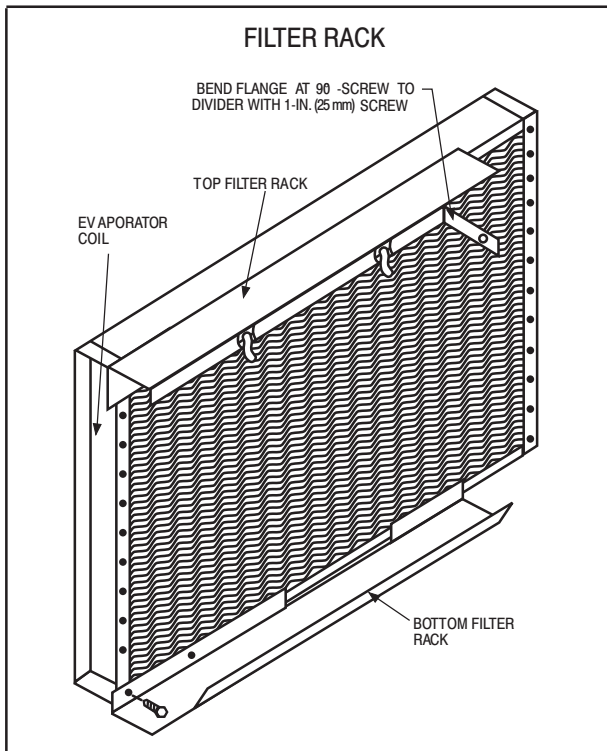

A09375

# UNIT DIMENSIONS - 24-30

UNIT	ELECTRICAL CHARACTERISTICS	UNIT WT.		UNIT HEIGHT IN/MM	CENTER OF GRAVITY IN/MM				
		LB	KG		X	Y	Z		
50VT-C24---30	208/230-1-60	311	141.0	47-3/4	521	15-1/2	394	16-1/2	419
50VT-C30---30	208/230-1-60	351	159.2	51-3/4	521	15-1/2	394	16-1/2	419

UNIT	VOLTAGE	CORNER WEIGHT LB/KG		
		"1"	"2"	"3"
24	208/230	46.7	21.2	62.2
30	208/230	52.7	23.9	70.2

### REQUIRED CLEARANCES TO COMBUSTIBLE MATL.

	INCHES [MM]
TOP OF UNIT.....	14 [355.6]
DUCT SIDE OF UNIT.....	2 [50.8]
SIDE OPPOSITE DUCTS.....	14 [355.6]
BOTTOM OF UNIT.....	0 [0.0]
ELECTRICAL PANEL.....	36 [914.4]

### NEC. REQUIRED CLEARANCES.

	INCHES [MM]
BETWEEN UNITS, POWER ENTRY SIDE.....	42 [1066.8]
UNIT AND UNGROUNDED SURFACES, POWER ENTRY SIDE.....	36 [914.0]
UNIT AND BLOCK OR CONCRETE WALLS AND OTHER GROUNDED SURFACES, POWER ENTRY SIDE.....	42 [1066.8]

### REQUIRED CLEARANCE FOR OPERATION AND SERVICING

	INCHES [MM]
EVAP. COIL ACCESS SIDE.....	36 [914.0]
POWER ENTRY SIDE.....	42 [1066.8]
(EXCEPT FOR NEC REQUIREMENTS)	
UNIT TOP.....	48 [1219.2]
SIDE OPPOSITE DUCTS.....	36 [914.0]
DUCT PANEL.....	12 [304.8]

\*MINIMUM DISTANCES: IF UNIT IS PLACED LESS THAN 12 [304.8] FROM WALL SYSTEM, THEN SYSTEM PERFORMANCE MAYBE COMPROMISED.

DIMENSIONS IN [ ] ARE IN MILLIMETERS

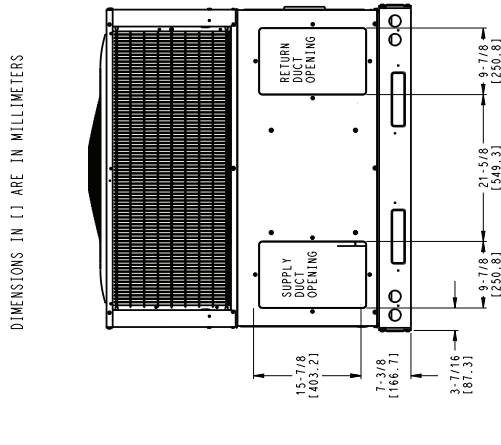
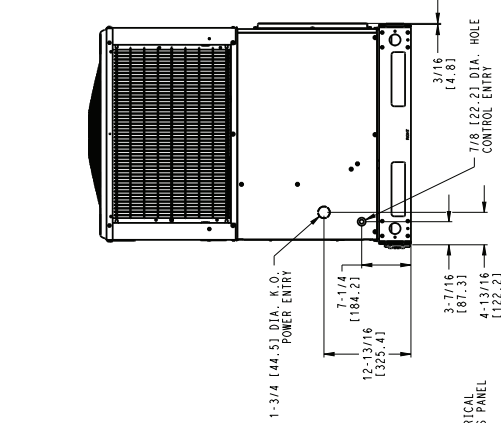
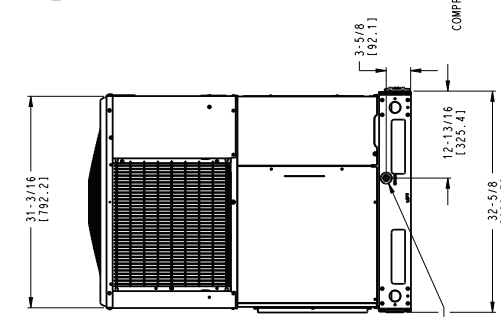
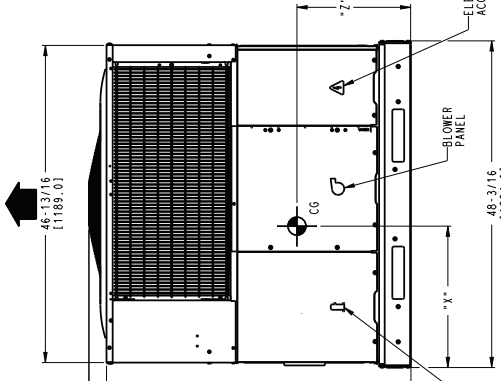
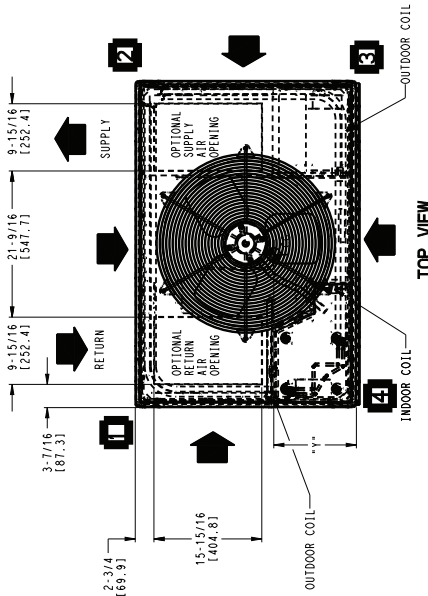

50VT500410

50VT



# ROOF CURB ACCESSORY DIMENSIONS

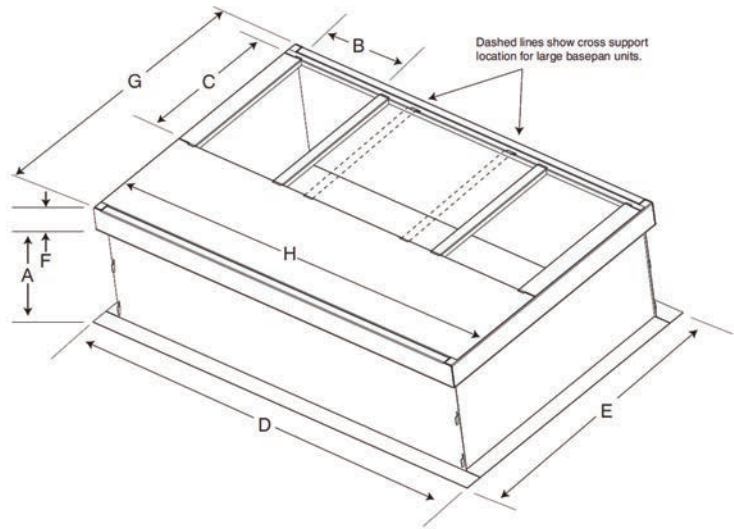
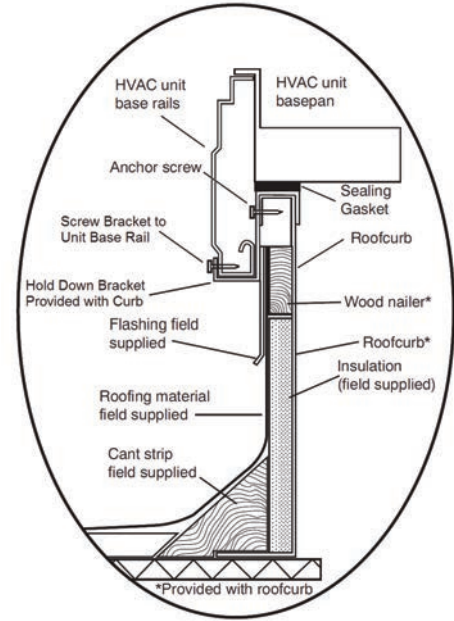

SMALL/COMMON CURB

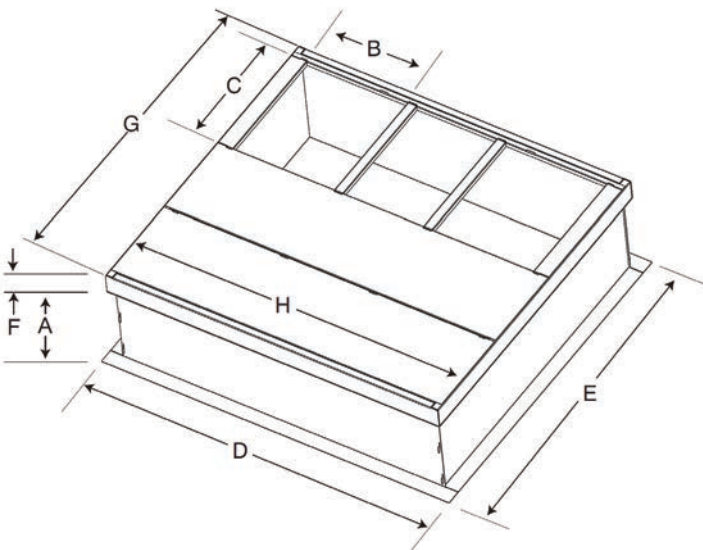

LARGE CURB

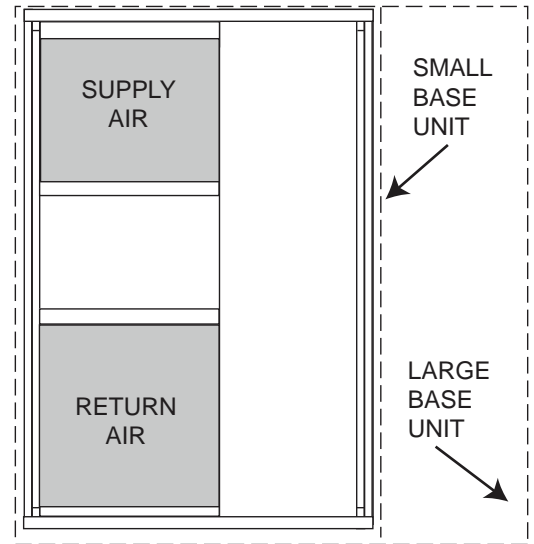

UNIT PLACEMENT ON COMMON CURB

SMALL OR LARGE BASE UNIT

A180216

UNIT SIZE	CATALOG NUMBER	A IN. (mm)	B (small/common base) IN. (mm)*	B (large base) IN. (mm)*	C IN. (mm)	D IN. (mm)	E IN. (mm)	F IN. (mm)	G IN. (mm)	H IN. (mm)
Small or Large	CPRFCURB011B00	14 (356)	10 (254)	14 (356)	16 (406)	47.8 (1214)	32.4 (822)	2.7 (69)	30.6 (778)	46.1 (1170)
Large	CPRFCURB013B00	14 (356)	14 (356)				43.9 (1116)		42.2 (1072)	

\* Part Number CPRFCURB011B00 can be used on both small and large basepan units. The cross supports must be located based on whether the unit is a small basepan or a large basepan.

NOTES:

1. Roof curb must be set up for unit being installed.
2. Seal strip must be applied, as required, to unit being installed.
3. Roof curb is made of 16-gauge steel.
4. Attach ductwork to curb (flanges of duct rest on curb).
5. Insulated panels: 1-in. (25 mm) thick fiberglass 1 lb. density.

50VT

## SELECTION PROCEDURE (WITH EXAMPLE)

### 1. Determine cooling and heating requirements at design conditions:

Given:

Required Cooling Capacity (TC) ..... 34,500 Btuh  
Sensible Heat Capacity (SHC) ..... 26,000 Btuh  
Required Heating Capacity ..... 60,000 Btuh  
Condenser Entering Air Temperature ..... 95°F (35°C)  
Indoor-Air Temperature 80°F (27°C) edb 67°F (19°C) ewb  
Evaporator Air Quantity ..... 1200 CFM  
External Static Pressure ..... 0.200 IN. W.C.  
Electrical Characteristics ..... 208-1-60

### 2. Select unit based on required cooling capacity.

Enter Net Cooling Capacities table at condenser entering temperature of 95°F (35°C). Unit 36 at 1200 CFM and 67°F (19°C) ewb (entering wet bulb) will provide a total capacity of 35,800 Btuh and a SHC of 26,950 Btuh. Calculate SHC correction, if required, using Note 4 under Cooling Capacities tables.

### 3. Select heating capacity of unit to provide design condition requirement.

In the Heating Capacities and Efficiencies table, note that the 36 size unit will deliver 34,800 BTUH at the AHRI high temp rating point. To achieve 60,000 BTUH, accessory electric heat will be required. Use the Balance Point Worksheet to plot the load line with the unit capacity. The difference between the load line and unit capacity at the design heating temperature is the amount of electric heat that will be required.

### 4. Determine fan speed and power requirements at design conditions.

Before entering the air delivery tables, calculate the total static pressure required. From the given example, the Wet Coil Pressure Drop Table, and the Filter Pressure Drop Table:

External Static Pressure	0.200 IN. W.C.
Filter	0.130 IN. W.C.
Wet Coil Pressure Drop	<u>0.18</u> IN. W.C.
Total Static Pressure	0.51 IN. W.C.

Enter the table for Dry Coil Air Delivery— At 0.50 IN. W.C. ESP (external static pressure) and MED-LOW speed the motor delivers 1140 CFM. To achieve 1200 CFM, a higher speed tap is required.

### 5. Select unit that corresponds to power source available.

The Electrical Data Table shows that the unit is designed to operate at 208/230-1-60.

# PERFORMANCE DATA

## 24 Cooling Extended Performance Table

EVAPORATOR AIR		CONDENSER ENTERING AIR TEMPERATURES °F (°C)																				
		75 (23.9)			85 (29.4)			95 (35)			105 (40.6)			115 (46.1)			125 (51.7)					
		CFM	EWB °F (°C)	Capacity MBtuh		Total Sys KW	Capacity MBtuh	Total Sys KW	Capacity MBtuh		Total Sys KW	Capacity MBtuh	Total Sys KW	Capacity MBtuh		Total Sys KW	Capacity MBtuh	Total Sys KW	Capacity MBtuh		Total Sys KW	
Total	Sens			Total	Sens				Total	Sens				Total	Sens				Total	Sens		
700	57 (13.9)	23.20	23.20	21.89	1.46	1.66	20.49	1.88	19.02	2.13	17.49	2.41	15.90	2.74	15.90	2.41	15.90	2.74	15.90	2.41	15.90	2.74
	62 (16.7)	23.93	21.62	20.71	1.46	1.66	20.71	1.88	19.05	2.13	17.52	2.41	15.92	2.74	15.92	2.41	15.92	2.74	15.92	2.41	15.92	2.74
	63* (17.2)	24.31	17.61	16.85	1.46	1.66	21.03	1.88	19.29	2.13	17.49	2.41	15.64	2.74	15.64	2.41	15.64	2.74	15.64	2.41	15.64	2.74
	67 (19.4)	26.08	18.23	17.45	1.47	1.67	22.58	1.90	20.74	2.15	18.83	2.43	16.87	2.75	16.87	2.43	16.87	2.75	16.87	2.43	16.87	2.75
	72 (22.2)	28.46	14.83	14.07	1.48	1.69	24.70	1.91	22.73	2.17	20.69	2.46	18.58	2.78	18.58	2.46	18.58	2.78	18.58	2.46	18.58	2.78
	57 (13.9)	24.19	24.19	22.79	1.48	1.68	21.30	1.90	19.75	2.15	18.14	2.44	16.47	2.77	16.47	2.44	16.47	2.77	16.47	2.44	16.47	2.77
	62 (16.7)	24.54	23.19	22.23	1.48	1.68	21.33	1.90	19.78	2.15	18.17	2.44	16.49	2.77	16.49	2.44	16.49	2.77	16.49	2.44	16.49	2.77
800	63* (17.2)	24.87	18.76	17.97	1.48	1.68	21.43	1.90	19.63	2.15	17.77	2.44	15.88	2.76	15.88	2.44	15.88	2.76	15.88	2.44	15.88	2.76
	67 (19.4)	26.67	19.46	18.65	1.48	1.69	23.00	1.92	21.09	2.17	19.13	2.45	17.11	2.77	17.11	2.45	17.11	2.77	17.11	2.45	17.11	2.77
	72 (22.2)	29.10	15.59	14.82	1.49	1.71	25.15	1.94	23.10	2.19	20.99	2.48	18.80	2.80	18.80	2.48	18.80	2.80	18.80	2.48	18.80	2.80
	57 (13.9)	25.03	25.03	23.55	1.50	1.70	21.99	1.93	20.36	2.18	18.68	2.47	16.94	2.79	16.94	2.47	16.94	2.79	16.94	2.47	16.94	2.79
	62 (16.7)	25.10	25.10	23.58	1.50	1.70	22.02	1.93	20.39	2.18	18.71	2.47	16.96	2.79	16.96	2.47	16.96	2.79	16.96	2.47	16.96	2.79
	63* (17.2)	25.31	19.86	19.04	1.50	1.70	21.75	1.92	19.90	2.17	18.00	2.46	16.08	2.78	16.08	2.46	16.08	2.78	16.08	2.46	16.08	2.78
	67 (19.4)	27.13	20.64	19.81	1.50	1.71	23.33	1.94	21.37	2.19	19.36	2.48	17.30	2.80	17.30	2.48	17.30	2.80	17.30	2.48	17.30	2.80
72 (22.2)	29.60	16.31	15.52	1.51	1.73	25.50	1.96	23.39	2.21	21.21	2.50	18.98	2.82	18.98	2.50	18.98	2.82	18.98	2.50	18.98	2.82	

\*At 75°F (23.9 °C) entering dry bulb—Tennessee Valley Authority [TVA] rating conditions; all others at 80°F (26.7 °C) entering dry bulb. See Legend and Notes.

## 24 Heating Extended Performance Table -10-60°F (-23.3-15.6°C)

INDOOR AIR		OUTDOOR COIL ENTERING AIR TEMPERATURES °F (°C)																							
		-10 (-23.3)			0 (-17.8)			10 (-12.2)			20 (-6.7)			30 (-1.1)			40 (4.4)			50 (10)			60 (15.6)		
		EDB °F (°C)	CFM	Capacity MBtuh		Total Sys KW	Capacity MBtuh	Total Sys KW	Capacity MBtuh		Total Sys KW	Capacity MBtuh	Total Sys KW	Capacity MBtuh		Total Sys KW	Capacity MBtuh	Total Sys KW	Capacity MBtuh		Total Sys KW	Capacity MBtuh	Total Sys KW		
Total	Integ			Total	Integ				Total	Integ				Total	Integ				Total	Integ				Total	Integ
65 (18.3)	700	5.16	4.74	1.30	7.34	6.76	1.36	9.88	9.07	1.42	13.05	11.84	1.49	16.15	14.15	1.54	19.76	19.76	1.60	23.93	23.93	1.67	28.94	28.94	1.78
	800	5.23	4.81	1.31	7.44	6.84	1.37	10.00	9.18	1.42	13.17	11.94	1.48	16.30	14.28	1.52	19.97	19.97	1.57	24.23	24.23	1.64	29.26	29.26	1.71
	900	5.29	4.87	1.32	7.52	6.92	1.37	10.10	9.27	1.42	13.27	12.04	1.47	16.43	14.40	1.51	20.15	20.15	1.56	24.47	24.47	1.61	29.31	29.31	1.67
70 (21.1)	700	4.96	4.56	1.36	7.13	6.56	1.42	9.64	8.85	1.49	12.86	11.66	1.56	15.94	13.96	1.62	19.49	19.49	1.68	23.59	23.59	1.72	28.47	28.47	1.86
	800	5.04	4.63	1.36	7.23	6.65	1.43	9.77	8.97	1.48	12.99	11.78	1.55	16.09	14.10	1.60	19.70	19.70	1.65	23.88	23.88	1.72	28.78	28.78	1.80
	900	5.11	4.70	1.37	7.31	6.73	1.43	9.88	9.07	1.48	13.11	11.89	1.54	16.23	14.22	1.59	19.88	19.88	1.63	24.12	24.12	1.69	29.00	29.00	1.76
75 (23.9)	700	4.74	4.36	1.42	6.89	6.34	1.49	9.39	8.62	1.56	12.31	11.16	1.62	15.73	13.78	1.70	19.22	19.22	1.76	23.28	23.28	1.84	28.02	28.02	1.95
	800	4.81	4.43	1.43	6.99	6.44	1.49	9.52	8.74	1.55	12.51	11.34	1.61	15.89	13.92	1.68	19.43	19.43	1.73	23.53	23.53	1.80	28.43	28.43	1.90
	900	4.89	4.50	1.44	7.08	6.52	1.50	9.63	8.84	1.55	12.71	11.53	1.61	16.01	14.03	1.67	19.61	19.61	1.71	23.77	23.77	1.78	28.65	28.65	1.85



PERFORMANCE DATA (CONT)

30 Cooling Extended Performance Table

EVAPORATOR AIR		CONDENSER ENTERING AIR TEMPERATURES °F (°C)																	
		75 (23.9)			85 (29.4)			95 (35)			105 (40.6)			115 (46.1)			125 (51.7)		
		CFM	EWB °F (°C)	Capacity MBtuh		Total Sys KW	Capacity MBtuh		Total Sys KW	Capacity MBtuh		Total Sys KW	Capacity MBtuh		Total Sys KW	Capacity MBtuh		Total Sys KW	
Total	Sens			Total	Sens		Total	Sens		Total	Sens		Total	Sens					
875	57 (13.9)	29.07	29.07	1.88	27.22	27.22	2.14	25.32	25.32	2.43	23.37	23.37	2.76	21.36	21.36	3.15	19.29	19.29	3.60
	62 (16.7)	29.99	25.80	1.89	27.81	24.76	2.14	25.64	23.67	2.43	23.47	23.30	2.76	21.39	21.39	3.15	19.32	19.32	3.60
	63* (17.2)	30.49	21.01	1.89	28.28	20.08	2.15	26.05	19.11	2.43	23.78	18.10	2.77	21.43	17.04	3.15	19.04	15.94	3.60
	67 (19.4)	32.82	21.81	1.91	30.45	20.88	2.16	28.08	19.91	2.45	25.64	18.90	2.78	23.16	17.85	3.17	20.61	16.76	3.60
	72 (22.2)	36.00	17.71	1.93	33.44	16.84	2.19	30.86	15.95	2.48	28.22	15.04	2.81	25.53	14.11	3.19	22.78	13.13	3.62
	57 (13.9)	30.31	30.31	1.92	28.34	28.34	2.18	26.34	26.34	2.47	24.28	24.28	2.80	22.17	22.17	3.19	19.99	19.99	3.64
	62 (16.7)	30.74	27.66	1.92	28.52	26.50	2.18	26.38	26.38	2.47	24.32	24.32	2.80	22.20	22.20	3.19	20.02	20.02	3.64
1000	63* (17.2)	31.18	22.37	1.93	28.86	21.41	2.18	26.55	20.41	2.47	24.19	19.37	2.80	21.78	18.26	3.19	19.33	17.11	3.63
	67 (19.4)	33.54	23.28	1.94	31.07	22.31	2.20	28.60	21.30	2.49	26.08	20.25	2.82	23.52	19.15	3.20	20.91	18.02	3.64
	72 (22.2)	36.76	18.67	1.96	34.09	17.77	2.22	31.41	16.84	2.51	28.68	15.90	2.84	25.91	14.92	3.22	23.08	13.91	3.66
	57 (13.9)	31.37	31.37	1.96	29.29	29.29	2.22	27.19	27.19	2.51	25.04	25.04	2.84	22.83	22.83	3.23	20.57	20.57	3.67
	62 (16.7)	31.43	31.43	1.96	29.33	29.33	2.22	27.23	27.23	2.51	25.07	25.07	2.84	22.86	22.86	3.23	20.59	20.59	3.67
	63* (17.2)	31.70	23.68	1.96	29.31	22.69	2.22	26.93	21.64	2.50	24.52	20.54	2.84	22.05	19.41	3.22	19.56	18.20	3.67
	67 (19.4)	34.09	24.70	1.98	31.54	23.68	2.23	29.00	22.63	2.52	26.42	21.53	2.85	23.79	20.40	3.24	21.13	19.20	3.68
72 (22.2)	37.37	19.54	2.00	34.61	18.61	2.26	31.85	17.66	2.55	29.03	16.69	2.88	26.19	15.69	3.26	23.29	14.66	3.69	

\*At 75°F (23.9 °C) entering dry bulb—Tennessee Valley Authority (TVA) rating conditions; all others at 80°F (26.7 °C) entering dry bulb. See Legend and Notes.

30 Heating Extended Performance Table -10-60°F (-23.3-15.6°C)

INDOOR AIR		OUTDOOR COIL ENTERING AIR TEMPERATURES °F (°C)																							
		-10 (-23.3)			0 (-17.8)			10 (-12.2)			20 (-6.7)			30 (-1.1)			40 (4.4)			50 (10)			60 (15.6)		
		EDB °F (°C)	CFM	Capacity MBtuh		Total Sys KW	Capacity MBtuh		Total Sys KW	Capacity MBtuh		Total Sys KW	Capacity MBtuh		Total Sys KW	Capacity MBtuh		Total Sys KW	Capacity MBtuh		Total Sys KW				
Total	Integ			Total	Integ		Total	Integ		Total	Integ		Total	Integ		Total	Integ								
65 (18.3)	875	7.37	6.78	1.70	10.15	9.34	1.76	16.92	15.35	1.88	20.92	18.33	1.95	25.08	25.08	2.01	29.90	29.90	2.09	35.71	35.71	2.21			
	1000	7.52	6.92	1.72	10.33	9.50	1.77	13.47	12.37	1.82	17.43	15.81	1.93	25.36	25.36	1.98	30.29	30.29	2.06	36.23	36.23	2.16			
	1125	7.66	7.04	1.74	10.49	9.65	1.79	13.66	12.53	1.83	17.61	16.08	1.93	25.59	25.59	1.97	30.61	30.61	2.04	36.66	36.66	2.14			
70 (21.1)	875	6.96	6.40	1.77	9.76	8.98	1.84	12.89	11.83	1.90	16.44	14.91	1.97	20.65	18.10	2.04	24.77	24.77	2.11	29.48	29.48	2.19			
	1000	7.11	6.54	1.79	9.94	9.15	1.85	13.09	12.02	1.90	16.70	15.15	1.96	20.88	18.30	2.03	25.05	25.05	2.08	29.87	29.87	2.16			
	1125	7.24	6.66	1.81	10.09	9.28	1.87	13.27	12.18	1.91	16.95	15.37	1.97	21.07	18.46	2.02	25.28	25.28	2.07	30.18	30.18	2.13			
75 (23.9)	875	6.52	6.00	1.85	9.34	8.59	1.92	12.48	11.46	1.99	16.02	14.53	2.06	20.40	17.87	2.15	24.46	24.46	2.21	29.09	29.09	2.24			
	1000	6.67	6.13	1.87	9.52	8.76	1.93	12.69	11.65	1.99	16.28	14.76	2.05	20.61	18.06	2.13	24.73	24.73	2.18	29.44	29.44	2.26			
	1125	6.80	6.25	1.89	9.67	8.90	1.95	12.87	11.82	2.00	16.49	14.96	2.08	20.80	18.22	2.12	24.96	24.96	2.17	29.75	29.75	2.24			

# PERFORMANCE DATA (CONT)

## 36 Cooling Extended Performance Table

EVAPORATOR AIR		CONDENSER ENTERING AIR TEMPERATURES °F (°C)																	
		75 (23.9)			85 (29.4)			95 (35)			105 (40.6)			115 (46.1)			125 (51.7)		
		CFM	EWB °F (°C)	Capacity MBtuh		Total Sys KW	Capacity MBtuh		Total Sys KW	Capacity MBtuh		Total Sys KW	Capacity MBtuh		Total Sys KW	Capacity MBtuh		Total Sys KW	
Total	Sens			Total	Sens		Total	Sens		Total	Sens		Total	Sens					
1050	57 (13.9)	34.29	34.29	2.28	31.97	31.97	2.57	29.65	29.65	2.91	27.29	27.29	3.30	24.91	24.91	3.75	22.51	22.51	4.28
	62 (16.7)	35.83	31.87	2.28	33.11	30.41	2.58	30.40	28.91	2.91	27.69	27.37	3.30	24.97	24.97	3.75	22.54	22.54	4.28
	63* (17.2)	36.58	26.06	2.29	33.81	24.75	2.58	31.02	23.43	2.92	28.22	22.09	3.31	25.40	20.75	3.76	22.56	19.38	4.28
	67 (19.4)	39.49	27.08	2.30	36.51	25.75	2.60	33.53	24.42	2.94	30.54	23.07	3.33	27.53	21.71	3.78	24.50	20.33	4.29
	72 (22.2)	43.46	22.18	2.33	40.22	20.97	2.63	36.98	19.76	2.97	33.73	18.53	3.36	30.47	17.30	3.80	27.18	16.04	4.31
	57 (13.9)	35.76	35.76	2.31	33.32	33.32	2.61	30.86	30.86	2.95	28.38	28.38	3.34	25.88	25.88	3.79	23.36	23.36	4.31
1200	62 (16.7)	36.70	34.09	2.32	33.91	32.51	2.61	31.14	30.87	2.95	28.43	28.43	3.34	25.91	25.91	3.79	23.38	23.38	4.31
	63* (17.2)	37.43	27.64	2.32	34.56	26.28	2.62	31.66	24.91	2.95	28.77	23.53	3.34	25.86	22.13	3.79	22.94	20.71	4.31
	67 (19.4)	40.37	28.77	2.34	37.29	27.39	2.64	34.20	26.00	2.97	31.11	24.60	3.36	28.01	23.19	3.81	24.89	21.76	4.32
	72 (22.2)	44.39	23.24	2.36	41.05	22.00	2.67	37.70	20.75	3.01	34.35	19.49	3.39	30.98	18.21	3.84	27.60	16.93	4.35
	57 (13.9)	37.01	37.01	2.35	34.46	34.46	2.65	31.89	31.89	2.98	29.30	29.30	3.37	26.69	26.69	3.83	24.06	24.06	4.35
	62 (16.7)	37.46	36.08	2.35	34.56	34.56	2.65	31.92	31.92	2.98	29.33	29.33	3.37	26.72	26.72	3.83	24.09	24.09	4.35
1350	63* (17.2)	38.10	29.14	2.35	35.13	27.74	2.65	32.17	26.32	2.98	29.19	24.89	3.37	26.21	23.44	3.82	23.24	21.94	4.34
	67 (19.4)	41.06	30.38	2.37	37.88	28.95	2.67	34.72	27.51	3.01	31.55	26.07	3.39	28.36	24.61	3.84	25.19	23.11	4.35
	72 (22.2)	45.13	24.24	2.40	41.68	22.96	2.70	38.26	21.68	3.04	34.81	20.39	3.43	31.36	19.09	3.87	27.91	17.77	4.38

\*AT 75°F (23.9 °C) entering dry bulb—Tennessee Valley Authority (TVA) rating conditions; all others at 80°F (26.7 °C) entering dry bulb. See Legend and Notes.

## 36 Heating Extended Performance Table -10-60°F (-23.3-15.6°C)

INDOOR AIR		OUTDOOR COIL ENTERING AIR TEMPERATURES °F (°C)																							
		-10 (-23.3)			0 (-17.8)			10 (-12.2)			20 (-6.7)			30 (-1.1)			40 (4.4)			50 (10)			60 (15.6)		
		EDB °F (°C)	CFM	Capacity MBtuh		Total Sys KW	Capacity MBtuh		Total Sys KW	Capacity MBtuh		Total Sys KW	Capacity MBtuh		Total Sys KW	Capacity MBtuh		Total Sys KW	Capacity MBtuh		Total Sys KW				
Total	Integ			Total	Integ		Total	Integ		Total	Integ		Total	Integ		Total	Integ		Total	Integ					
65 (18.3)	1050	8.91	8.20	1.99	12.09	11.12	2.10	15.84	14.54	2.20	20.16	18.29	2.31	25.50	22.34	2.46	30.51	30.51	2.59	36.18	36.18	2.74	42.89	42.89	2.94
	1200	9.08	8.35	2.00	12.29	11.31	2.10	16.09	14.77	2.19	20.48	18.57	2.29	25.78	22.58	2.42	30.85	30.85	2.54	36.62	36.62	2.68	43.51	43.51	2.86
	1350	9.23	8.49	2.02	12.47	11.48	2.11	16.30	14.96	2.19	20.74	18.81	2.28	25.99	22.77	2.40	31.14	31.14	2.51	36.99	36.99	2.63	44.03	44.03	2.80
70 (21.1)	1050	8.38	7.71	2.09	11.57	10.64	2.20	15.32	14.06	2.30	19.62	17.80	2.42	25.09	21.99	2.58	30.10	30.10	2.71	35.72	35.72	2.87	42.28	42.28	3.08
	1200	8.55	7.86	2.10	11.77	10.83	2.20	15.57	14.29	2.30	19.93	18.08	2.40	25.40	22.25	2.54	30.44	30.44	2.66	36.14	36.14	2.80	42.89	42.89	2.99
	1350	8.69	8.00	2.12	11.95	10.99	2.21	15.78	14.49	2.30	20.20	18.32	2.39	25.64	22.47	2.62	30.73	30.73	2.63	36.50	36.50	2.76	43.39	43.39	2.93
75 (23.9)	1050	7.83	7.20	2.20	11.02	10.14	2.30	14.78	13.56	2.41	19.06	17.29	2.53	24.02	21.05	2.67	29.70	29.70	2.85	35.30	35.30	3.01	41.68	41.68	3.22
	1200	7.98	7.34	2.21	11.22	10.32	2.31	15.02	13.79	2.41	19.37	17.57	2.51	24.54	21.50	2.64	30.03	30.03	2.79	35.70	35.70	2.94	42.27	42.27	3.13
	1350	8.12	7.47	2.22	11.40	10.49	2.32	15.24	13.98	2.41	19.63	17.80	2.50	25.23	22.10	2.64	30.31	30.31	2.75	36.01	36.01	2.89	42.76	42.76	3.07

50VT

PERFORMANCE DATA (CONT)

42 Cooling Extended Performance Table

EVAPORATOR AIR		CONDENSER ENTERING AIR TEMPERATURES °F (°C)																	
CFM	EWB °F (°C)	75 (23.9)			85 (29.4)			95 (35)			105 (40.6)			115 (46.1)			125 (51.7)		
		Capacity MBtuh	Total Sys KW	Sens	Capacity MBtuh	Total Sys KW	Sens	Capacity MBtuh	Total Sys KW	Sens	Capacity MBtuh	Total Sys KW	Sens	Capacity MBtuh	Total Sys KW	Sens	Capacity MBtuh	Total Sys KW	Sens
1175	57 (13.9)	41.22	2.67	38.65	3.02	36.03	3.43	33.36	3.92	30.67	4.50	27.95	5.18						
	62 (16.7)	42.88	2.68	39.82	3.03	36.79	3.45	33.74	3.93	30.72	4.50	28.00	5.18						
	63* (17.2)	43.45	2.69	40.36	3.04	37.28	3.45	34.17	3.94	31.05	4.51	27.90	5.18						
	67 (19.4)	46.78	2.73	43.42	3.08	40.10	3.50	36.77	4.00	33.43	4.58	30.08	5.25						
	72 (22.2)	51.06	2.78	47.40	3.14	43.79	3.57	40.20	4.08	36.60	4.68	32.99	5.37						
	57 (13.9)	43.16	2.73	40.38	3.08	37.57	3.50	34.75	4.00	31.90	4.58	29.02	5.26						
	62 (16.7)	44.08	2.74	40.92	3.09	37.79	3.51	34.81	3.99	31.95	4.58	29.06	5.26						
1350	63* (17.2)	44.59	2.75	41.33	3.10	38.10	3.51	34.87	4.00	31.64	4.57	28.39	5.24						
	67 (19.4)	47.99	2.78	44.45	3.14	41.00	3.57	37.54	4.06	34.07	4.64	30.60	5.32						
	72 (22.2)	52.34	2.84	48.53	3.21	44.76	3.64	41.02	4.15	37.28	4.75	33.55	5.44						
	57 (13.9)	44.79	2.79	41.81	3.15	38.87	3.57	35.90	4.07	32.91	4.66	29.90	5.34						
	62 (16.7)	45.17	2.79	41.88	3.15	38.92	3.57	35.95	4.07	32.96	4.66	29.94	5.35						
	63* (17.2)	45.49	2.80	42.10	3.15	38.77	3.57	35.43	4.06	32.09	4.63	28.77	5.30						
	67 (19.4)	48.94	2.84	45.27	3.20	41.68	3.62	38.10	4.12	34.56	4.71	31.00	5.39						
72 (22.2)	53.35	2.90	49.40	3.27	45.51	3.70	41.65	4.21	37.80	4.81	33.97	5.51							

\*At 75°F (23.9 °C) entering dry bulb—Tennessee Valley Authority (TVA) rating conditions; all others at 80°F (26.7 °C) entering dry bulb. See Legend and Notes.

42 Heating Extended Performance Table -10-60°F (-23.3-15.6°C)

INDOOR AIR		OUTDOOR COIL ENTERING AIR TEMPERATURES °F (°C)																							
EDB °F (°C)	CFM	-10 (-23.3)			0 (-17.8)			10 (-12.2)			20 (-6.7)			30 (-1.1)			40 (4.4)			50 (10)			60 (15.6)		
		Capacity MBtuh	Total Sys KW	Sens	Capacity MBtuh	Total Sys KW	Sens	Capacity MBtuh	Total Sys KW	Sens	Capacity MBtuh	Total Sys KW	Sens	Capacity MBtuh	Total Sys KW	Sens	Capacity MBtuh	Total Sys KW	Sens	Capacity MBtuh	Total Sys KW	Sens			
65 (18.3)	1175	10.12	9.31	2.30	14.66	13.49	2.50	19.40	17.81	2.66	24.41	22.14	2.80	29.75	26.06	2.94	35.60	35.60	3.11	41.91	41.91	3.32	48.00	48.00	3.56
	1350	10.35	9.52	2.33	14.93	13.74	2.52	19.74	18.12	2.67	24.85	22.53	2.79	30.28	26.53	2.92	36.96	36.96	3.09	42.46	42.46	3.25	48.76	48.76	3.47
	1525	10.56	9.71	2.36	15.19	13.97	2.54	20.05	18.40	2.69	25.21	22.86	2.80	30.72	26.92	2.91	37.37	37.37	3.07	42.93	42.93	3.21	49.39	49.39	3.41
70 (21.1)	1175	9.48	8.72	2.42	13.96	12.84	2.62	18.67	17.13	2.78	23.68	21.48	2.92	28.98	25.39	3.07	34.72	34.72	3.24	41.44	41.44	3.48	47.32	47.32	3.73
	1350	9.71	8.94	2.45	14.25	13.11	2.64	19.04	17.47	2.79	24.12	21.88	2.92	29.51	25.86	3.05	35.45	35.45	3.21	41.94	41.94	3.41	48.04	48.04	3.64
	1525	9.91	9.12	2.48	14.51	13.36	2.66	19.35	17.76	2.81	24.49	22.21	2.93	29.96	26.25	3.04	36.79	36.79	3.21	42.34	42.34	3.37	48.65	48.65	3.57
75 (23.9)	1175	8.70	8.01	2.54	13.17	12.12	2.74	17.88	16.41	2.90	22.89	20.76	3.05	28.17	24.68	3.20	33.86	33.86	3.38	40.88	40.88	3.65	46.68	46.68	3.92
	1350	8.93	8.22	2.57	13.47	12.40	2.76	18.25	16.75	2.91	23.34	21.17	3.05	28.70	25.15	3.16	34.52	34.52	3.35	41.42	41.42	3.57	47.36	47.36	3.81
	1525	9.14	8.41	2.61	13.74	12.64	2.79	18.57	17.04	2.93	23.72	21.51	3.06	29.16	25.55	3.18	35.06	35.06	3.33	41.87	41.87	3.53	47.94	47.94	3.75

# PERFORMANCE DATA (CONT)

## 48 Cooling Extended Performance Table

EVAPORATOR AIR		CONDENSER ENTERING AIR TEMPERATURES °F (°C)																	
		75 (23.9)			85 (29.4)			95 (35)			105 (40.6)			115 (46.1)			125 (51.7)		
		CFM	EWB °F (°C)	Capacity MBtuh		Total Sys KW	Capacity MBtuh		Total Sys KW	Capacity MBtuh		Total Sys KW	Capacity MBtuh		Total Sys KW	Capacity MBtuh		Total Sys KW	
Total	Sens			Total	Sens		Total	Sens		Total	Sens		Total	Sens		Total	Sens		
1400	57 (13.9)	50.12	50.12	3.10	46.77	46.77	3.47	43.47	43.47	3.90	39.22	39.22	4.36	34.90	34.90	4.88	30.65	30.65	5.48
	62 (16.7)	51.55	44.71	3.10	47.78	41.45	3.48	44.03	38.34	3.91	39.31	39.31	4.36	34.97	34.97	4.88	30.70	30.70	5.48
	63* (17.2)	52.39	36.35	3.11	48.52	33.63	3.48	44.63	30.99	3.91	39.88	28.04	4.37	34.46	34.46	4.87	29.23	21.95	5.45
	67 (19.4)	55.61	37.17	3.13	51.57	34.45	3.51	47.38	31.68	3.94	43.53	29.46	4.42	38.57	38.57	4.97	23.55	23.55	5.53
	72 (22.2)	59.62	29.72	3.15	55.39	27.41	3.53	50.95	25.03	3.97	46.47	22.65	4.46	42.63	20.90	5.01	18.74	18.74	5.62
	57 (13.9)	51.78	51.78	3.16	48.29	48.29	3.54	44.77	44.77	3.97	41.24	41.24	4.46	36.65	36.65	4.99	32.12	32.12	5.57
	62 (16.7)	52.53	47.41	3.16	48.70	43.96	3.54	44.85	44.85	3.97	41.31	41.31	4.46	36.71	36.71	4.99	32.17	32.17	5.58
1600	63* (17.2)	53.23	38.40	3.17	49.26	35.59	3.54	45.25	32.81	3.97	40.90	30.12	4.46	35.28	35.28	4.95	23.64	23.64	5.52
	67 (19.4)	56.41	39.18	3.19	52.28	36.36	3.57	48.00	33.50	4.00	43.94	31.01	4.49	39.39	39.39	5.03	25.41	25.41	5.62
	72 (22.2)	60.37	30.80	3.21	56.05	28.44	3.59	51.53	25.98	4.03	46.91	23.51	4.53	42.97	21.80	5.08	19.80	19.80	5.69
	57 (13.9)	53.08	53.08	3.22	49.47	49.47	3.60	45.76	45.76	4.04	42.48	42.48	4.53	38.09	38.09	5.08	33.40	33.40	5.67
	62 (16.7)	53.36	49.71	3.22	49.54	49.54	3.60	45.79	45.79	4.04	42.53	42.53	4.53	38.15	38.15	5.08	33.45	33.45	5.67
	63* (17.2)	53.86	40.35	3.23	49.82	37.43	3.61	45.70	34.51	4.04	41.62	32.13	4.51	35.97	28.61	5.03	25.13	25.13	5.60
	67 (19.4)	57.01	41.09	3.25	52.81	38.19	3.63	48.44	35.21	4.06	44.19	32.41	4.55	39.90	30.52	5.09	27.16	27.16	5.70
72 (22.2)	60.93	31.81	3.27	56.55	29.40	3.65	51.95	26.88	4.09	47.23	24.35	4.59	43.19	22.58	5.15	20.77	20.77	5.75	

\*At 75°F (23.9 °C) entering dry bulb—Tennessee Valley Authority [TVA] rating conditions; all others at 80°F (26.7 °C) entering dry bulb. See Legend and Notes.

## 48 Heating Extended Performance Table - 10-60°F (-23.3-15.6°C)

INDOOR AIR		OUTDOOR COIL ENTERING AIR TEMPERATURES °F (°C)																							
		-10 (-23.3)			0 (-17.8)			10 (-12.2)			20 (-6.7)			30 (-1.1)			40 (4.4)			50 (10)			60 (15.6)		
		EDB CFM	Capacity MBtuh	Total Sys KW	Capacity MBtuh		Total Sys KW	Capacity MBtuh		Total Sys KW	Capacity MBtuh		Total Sys KW	Capacity MBtuh		Total Sys KW	Capacity MBtuh		Total Sys KW	Capacity MBtuh		Total Sys KW			
Total	Integ				Total	Integ		Total	Integ		Total	Integ		Total	Integ		Total	Integ		Total	Integ		Total	Integ	
65 (18.3)	1400	12.87	11.84	2.61	17.23	15.86	2.76	22.14	20.32	2.90	27.76	25.18	3.07	34.69	30.39	3.25	40.97	40.97	3.40	48.22	48.22	3.59	56.85	56.85	3.82
	1600	13.16	12.11	2.64	17.57	16.17	2.78	22.53	20.68	2.92	28.19	25.57	3.07	35.00	30.66	3.23	41.41	41.41	3.36	48.82	48.82	3.53	57.70	57.70	3.74
	1800	13.42	12.35	2.68	17.87	16.44	2.81	22.86	20.98	2.94	28.58	25.92	3.08	35.31	30.94	3.23	41.80	41.80	3.35	49.33	49.33	3.50	58.41	58.41	3.70
70 (21.1)	1400	12.17	11.19	2.71	16.57	15.24	2.87	21.48	19.71	3.02	27.09	24.56	3.19	34.27	30.03	3.40	40.56	40.56	3.56	47.61	47.61	3.75	56.05	56.05	3.99
	1600	12.45	11.45	2.75	16.90	15.55	2.89	21.85	20.06	3.04	27.53	24.96	3.20	34.66	30.37	3.38	40.97	40.97	3.52	48.20	48.20	3.70	56.84	56.84	3.90
	1800	12.71	11.69	2.79	17.18	15.80	2.92	22.19	20.36	3.06	27.91	25.31	3.21	34.99	30.66	3.38	41.34	41.34	3.50	48.71	48.71	3.67	57.58	57.58	3.87
75 (23.9)	1400	11.44	10.52	2.82	15.86	14.59	2.99	20.79	19.09	3.15	26.39	23.94	3.33	32.89	28.81	3.51	40.10	40.10	3.73	47.02	47.02	3.93	55.27	55.27	4.18
	1600	11.72	10.78	2.86	16.18	14.89	3.01	21.17	19.43	3.17	26.83	24.34	3.33	33.55	29.40	3.50	40.56	40.56	3.69	47.59	47.59	3.87	56.04	56.04	4.09
	1800	11.97	11.01	2.90	16.47	15.16	3.04	21.50	19.73	3.19	27.21	24.68	3.34	34.55	30.27	3.53	40.92	40.92	3.67	48.08	48.08	3.83	56.73	56.73	4.04

50VT

50VT

PERFORMANCE DATA (CONT)

60 Cooling Extended Performance Table

EVAPORATOR AIR		CONDENSER ENTERING AIR TEMPERATURES °F (°C)																	
		75 (23.9)			85 (29.4)			95 (35)			105 (40.6)			115 (46.1)			125 (51.7)		
		CFM	EWB °F (°C)	Capacity MBtuh		Total Sys KW	Capacity MBtuh		Total Sys KW	Capacity MBtuh		Total Sys KW	Capacity MBtuh		Total Sys KW	Capacity MBtuh		Total Sys KW	
Total	Sens			Total	Sens		Total	Sens		Total	Sens		Total	Sens					
1750	57 (13.9)	59.01	59.01	3.86	55.84	55.84	4.36	52.53	52.53	4.95	49.01	49.01	5.63	45.25	45.25	6.42	41.25	41.25	7.30
	62 (16.7)	60.65	51.45	3.87	56.94	49.66	4.37	53.07	47.70	4.96	49.10	49.10	5.63	45.32	45.32	6.42	41.31	41.31	7.30
	63* (17.2)	61.42	41.59	3.88	57.58	40.01	4.38	53.66	38.36	4.96	49.53	36.63	5.64	45.16	34.80	6.42	40.58	32.86	7.29
	67 (19.4)	65.91	43.15	3.90	61.77	41.51	4.41	57.50	39.80	5.00	53.02	38.01	5.68	48.31	36.13	6.46	43.40	34.17	7.34
	72 (22.2)	71.65	34.81	3.93	67.13	33.24	4.45	62.46	31.58	5.05	57.59	29.86	5.73	52.50	28.06	6.52	47.21	26.18	7.40
	57 (13.9)	61.36	61.36	3.95	57.93	57.93	4.46	54.38	54.38	5.05	50.64	50.64	5.73	46.62	46.62	6.52	42.39	42.39	7.41
	62 (16.7)	62.11	54.99	3.96	58.19	57.61	4.46	54.45	54.45	5.05	50.70	50.70	5.73	46.68	46.68	6.52	42.45	42.45	7.41
2000	63* (17.2)	62.66	44.18	3.96	58.67	42.54	4.46	54.56	40.83	5.05	50.26	39.04	5.73	45.71	37.12	6.51	41.01	35.05	7.38
	67 (19.4)	67.23	45.93	3.98	62.89	44.22	4.49	58.43	42.45	5.09	53.75	40.59	5.77	48.89	38.64	6.55	43.85	36.55	7.43
	72 (22.2)	73.06	36.47	4.01	68.34	34.84	4.53	63.48	33.14	5.13	58.41	31.35	5.82	53.15	29.51	6.61	47.69	27.59	7.49
	57 (13.9)	63.30	63.30	4.04	59.65	59.65	4.55	55.89	55.89	5.14	51.92	51.92	5.83	47.72	47.72	6.62	43.32	43.32	7.51
	62 (16.7)	63.38	63.38	4.04	59.73	59.73	4.55	55.96	55.96	5.14	51.98	51.98	5.83	47.77	47.77	6.62	43.36	43.36	7.51
	63* (17.2)	63.63	46.69	4.04	59.48	44.99	4.55	55.23	43.21	5.14	50.79	41.33	5.82	46.15	39.28	6.60	41.34	37.04	7.48
	67 (19.4)	68.23	48.62	4.06	63.75	46.87	4.58	59.13	45.03	5.17	54.33	43.09	5.86	49.34	41.00	6.64	44.19	38.75	7.52
72 (22.2)	74.14	38.06	4.09	69.26	36.38	4.61	64.22	34.62	5.22	59.02	32.81	5.91	53.61	30.91	6.70	48.02	28.95	7.59	

\*At 75°F (23.9 °C) entering dry bulb—Tennessee Valley Authority (TVA) rating conditions; all others at 80°F (26.7 °C) entering dry bulb. See Legend and Notes.

60 Heating Extended Performance Table -10-60°F (-23.3-15.6 °C)

INDOOR AIR		OUTDOOR COIL ENTERING AIR TEMPERATURES °F (°C)																							
		-10 (-23.3)			0 (-17.8)			10 (-12.2)			20 (-6.7)			30 (-1.1)			40 (4.4)			50 (10)			60 (15.6)		
		EDB °F (°C)	CFM	Capacity MBtuh		Total Sys KW	Capacity MBtuh		Total Sys KW	Capacity MBtuh		Total Sys KW	Capacity MBtuh		Total Sys KW	Capacity MBtuh		Total Sys KW	Capacity MBtuh		Total Sys KW				
Total	Integ			Total	Integ		Total	Integ		Total	Integ		Total	Integ		Total	Integ								
65 (18.3)	1750	17.66	16.25	3.76	23.16	21.31	3.84	29.24	26.84	3.95	35.94	32.60	4.09	43.49	38.10	4.26	52.28	47.47	60.79	4.67	70.82	66.87	4.91		
	2000	18.08	16.63	3.82	23.63	21.75	3.89	29.77	27.32	3.99	36.54	33.14	4.11	44.35	38.86	4.26	52.93	48.45	61.57	4.62	71.85	67.85	4.83		
	2250	18.45	16.97	3.89	24.06	22.13	3.95	30.23	27.75	4.04	37.06	33.61	4.15	45.80	40.13	4.31	53.47	49.45	62.27	4.60	72.73	68.73	4.79		
70 (21.1)	1750	16.61	15.28	3.89	22.18	20.41	3.98	28.31	25.98	4.10	35.03	31.77	4.25	42.48	37.22	4.43	51.67	46.7	60.02	4.88	69.83	65.83	5.12		
	2000	17.01	15.65	3.95	22.64	20.84	4.03	28.83	26.46	4.14	35.62	32.31	4.27	43.19	37.84	4.43	52.25	46.84	60.78	4.82	70.85	66.85	5.04		
	2250	17.37	15.98	4.02	23.05	21.21	4.09	29.29	26.86	4.18	36.14	32.77	4.31	43.80	38.38	4.45	52.80	47.42	61.42	4.80	71.71	67.71	5.00		
75 (23.9)	1750	15.54	14.30	4.03	21.18	19.49	4.13	27.35	25.10	4.26	34.10	30.93	4.42	41.52	36.38	4.61	50.99	46.88	59.24	5.09	68.87	64.87	5.35		
	2000	15.92	14.65	4.09	21.62	19.89	4.18	27.86	25.57	4.30	34.68	31.45	4.44	42.20	36.98	4.61	51.63	47.48	59.98	5.03	69.84	65.84	5.26		
	2250	16.27	14.97	4.16	22.03	20.27	4.24	28.31	25.99	4.34	35.19	31.92	4.47	42.78	37.48	4.63	52.15	48.4	60.64	5.01	70.69	66.69	5.21		

## PERFORMANCE DATA (CONT)

### LEGEND

BF — Bypass Factor  
 edb — Entering Dry – Bulb  
 Ewb — Entering Wet – Bulb  
 kW — Total Unit Power Input  
 SHC — Sensible Heat Capacity (1000 Btuh)  
 TC — Total Capacity (1000 Btuh) (net)  
 rh — Relative Humidity

### COOLING NOTES:

1. Ratings are net; they account for the effects of the evaporator – fan motor power and heat.
2. Direct interpolation is permissible. Do not extrapolate.
3. The following formulas may be used:

$$t_{ldb} = t_{edb} - \frac{\text{Sensible capacity (Btuh)}}{1.10 \times \text{CFM}}$$

$$t_{lwb} = \frac{\text{Wet-bulb temperature corresponding to enthalpy of air leaving evaporator coil (} t_{lwb} \text{)}}{\text{total capacity (Btuh)}}$$

$$h_{lwb} = h_{ewb} - 4.5 \times \text{CFM}$$

Where:  $h_{ewb}$  = Enthalpy of air entering evaporator coil

4. The SHC is based on 80° F (26.6° C) edb temperature of air entering evaporator coil. Below 80° F (26.6° C) edb, subtract (corr factor x CFM) from SHC.

Above 80° F (26.6° C) edb, add (corr factor x CFM) to SHC.  
 Correction Factor =  $1.10 \times (1 + \text{BF}) \times (\text{edb} - 80)$ .

5. Integrated capacity is maximum (instantaneous) capacity less the effect of frost on the outdoor coil and the heat required to defrost it.

### Multiplication Factors

HEATER VOLT RATING	VOLTAGE DISTRIBUTION	MULTIPLICATION FACTOR
240	200	0.69
	208	0.75
	230	0.92
	240	1.00
480	460	0.92

50VT

**Dry Coil Air Delivery\* - Horizontal and Downflow Discharge - Sizes 24-60 208/230VAC - 1 Phase**

Unit Size	Motor Speed	Wire Color	External Static Pressure (IN. W.C.)																		
			0.1	0.2	0.3	0.4	0.5	0.6	0.7	0.8	0.9	1									
24	Low	CFM	669	580	525	423	303	---	---	---	---	---	---	---	---	---	---	---	---	---	
		BHP	0.09	0.10	0.11	0.11	0.12	---	---	---	---	---	---	---	---	---	---	---	---	---	---
	Med - Low <sup>1</sup>	CFM	829	752	680	602	549	455	313	---	---	---	---	---	---	---	---	---	---	---	---
		BHP	0.14	0.15	0.15	0.16	0.17	0.17	0.18	---	---	---	---	---	---	---	---	---	---	---	---
	Medium	CFM	1014	929	884	818	746	683	600	537	405	305	---	---	---	---	---	---	---	---	---
		BHP	0.24	0.24	0.24	0.25	0.26	0.26	0.27	0.27	0.27	0.29	---	---	---	---	---	---	---	---	---
	Med - High	CFM	1041	972	916	850	782	713	631	581	465	340	---	---	---	---	---	---	---	---	---
		BHP	0.25	0.26	0.26	0.26	0.26	0.27	0.28	0.29	0.30	0.31	---	---	---	---	---	---	---	---	---
	High	CFM	1187	1124	1061	996	930	896	840	776	698	610	---	---	---	---	---	---	---	---	---
		BHP	0.36	0.36	0.37	0.37	0.38	0.38	0.39	0.39	0.39	0.40	---	---	---	---	---	---	---	---	---
30	Low	CFM	669	580	525	423	303	---	---	---	---	---	---	---	---	---	---	---	---	---	
		BHP	0.09	0.10	0.11	0.11	0.12	---	---	---	---	---	---	---	---	---	---	---	---	---	---
	Med - Low	CFM	829	752	680	602	549	455	313	---	---	---	---	---	---	---	---	---	---	---	---
		BHP	0.14	0.15	0.15	0.16	0.17	0.17	0.18	---	---	---	---	---	---	---	---	---	---	---	---
	Medium <sup>1</sup>	CFM	1014	929	884	818	746	683	600	537	405	305	---	---	---	---	---	---	---	---	---
		BHP	0.24	0.24	0.24	0.25	0.26	0.26	0.27	0.27	0.27	0.29	---	---	---	---	---	---	---	---	---
	Med - High	CFM	1041	972	916	850	782	713	631	581	465	340	---	---	---	---	---	---	---	---	---
		BHP	0.25	0.26	0.26	0.26	0.26	0.27	0.28	0.29	0.30	0.31	---	---	---	---	---	---	---	---	---
	High	CFM	1187	1124	1061	996	930	896	840	776	698	610	---	---	---	---	---	---	---	---	---
		BHP	0.36	0.36	0.37	0.37	0.38	0.38	0.39	0.39	0.39	0.40	---	---	---	---	---	---	---	---	---
36	Low	CFM	1117	1042	969	893	869	802	741	677	590	582	---	---	---	---	---	---	---	---	
		BHP	0.17	0.18	0.19	0.19	0.21	0.21	0.22	0.23	0.24	0.25	---	---	---	---	---	---	---	---	---
	Med - Low	CFM	1170	1094	1027	955	883	870	810	748	680	591	---	---	---	---	---	---	---	---	---
		BHP	0.19	0.20	0.21	0.22	0.23	0.24	0.24	0.25	0.26	0.26	---	---	---	---	---	---	---	---	---
	Medium <sup>1</sup>	CFM	1292	1246	1183	1124	1059	995	924	877	856	819	---	---	---	---	---	---	---	---	---
		BHP	0.25	0.26	0.28	0.29	0.30	0.31	0.32	0.33	0.34	0.34	---	---	---	---	---	---	---	---	---
	Med - High	CFM	1311	1225	1199	1145	1081	1015	952	902	885	843	---	---	---	---	---	---	---	---	---
		BHP	0.26	0.27	0.28	0.30	0.31	0.32	0.33	0.33	0.35	0.35	---	---	---	---	---	---	---	---	---
	High	CFM	1602	1535	1469	1404	1333	1260	1246	1192	1191	1131	---	---	---	---	---	---	---	---	---
		BHP	0.46	0.47	0.48	0.50	0.50	0.51	0.52	0.53	0.54	0.55	---	---	---	---	---	---	---	---	---
42	Low	CFM	1001	902	833	777	717	650	575	527	466	419	---	---	---	---	---	---	---	---	
		BHP	0.13	0.13	0.14	0.14	0.15	0.16	0.17	0.18	0.19	0.20	---	---	---	---	---	---	---	---	---
	Med - Low	CFM	1016	950	902	842	783	721	655	590	541	480	---	---	---	---	---	---	---	---	---
		BHP	0.13	0.14	0.15	0.16	0.17	0.18	0.19	0.20	0.21	0.22	---	---	---	---	---	---	---	---	---
	Medium <sup>1</sup>	CFM	1403	1358	1316	1265	1217	1167	1116	1067	1012	956	---	---	---	---	---	---	---	---	---
		BHP	0.29	0.30	0.31	0.33	0.34	0.35	0.36	0.37	0.38	0.39	---	---	---	---	---	---	---	---	---
	Med - High	CFM	1461	1411	1367	1327	1275	1220	1174	1127	1074	1022	---	---	---	---	---	---	---	---	---
		BHP	0.32	0.33	0.35	0.36	0.37	0.38	0.39	0.40	0.41	0.42	---	---	---	---	---	---	---	---	---
	High	CFM	1575	1528	1488	1447	1406	1360	1314	1264	1213	1159	---	---	---	---	---	---	---	---	---
		BHP	0.40	0.42	0.43	0.44	0.45	0.46	0.47	0.48	0.49	0.50	---	---	---	---	---	---	---	---	---

**Dry Coil Air Delivery\* - Horizontal and Downflow Discharge - Sizes 24-60 208/230VAC - 1 Phase (Cont.)**

Unit Size	Motor Speed	Wire Color	External Static Pressure (IN. W.C.)									
			0.1	0.2	0.3	0.4	0.5	0.6	0.7	0.8	0.9	1
48	Low	CFM	1378	1344	1295	1260	1216	1179	1135	1087	1035	995
		BHP	0.26	0.27	0.29	0.31	0.31	0.33	0.34	0.36	0.36	0.38
	Med – Low <sup>1</sup>	CFM	1696	1671	1631	1607	1574	1539	1507	1463	1432	1393
		BHP	0.45	0.47	0.49	0.50	0.52	0.52	0.54	0.55	0.57	0.58
	Medium	CFM	1994	1968	1943	1910	1882	1835	1774	1702	1614	1512
		BHP	0.72	0.73	0.75	0.76	0.78	0.78	0.76	0.73	0.70	0.66
	Med – High	CFM	2054	2013	1986	1964	1919	1854	1779	1695	1605	1498
		BHP	0.77	0.79	0.80	0.82	0.81	0.80	0.76	0.74	0.69	0.65
	High	CFM	2267	2201	2133	2071	1997	1923	1835	1739	1654	1551
		BHP	1.03	1.00	0.97	0.93	0.89	0.86	0.82	0.78	0.74	0.69
60	Low	CFM	1330	1277	1232	1191	1147	1103	1060	1004	963	919
		BHP	0.26	0.27	0.29	0.30	0.31	0.32	0.33	0.34	0.36	0.37
	Med – Low	CFM	1475	1436	1399	1351	1317	1270	1236	1188	1152	1105
		BHP	0.35	0.36	0.37	0.38	0.40	0.41	0.42	0.43	0.45	0.45
	Medium <sup>1</sup>	CFM	1736	1710	1668	1630	1600	1557	1522	1479	1450	1406
		BHP	0.53	0.54	0.55	0.58	0.59	0.60	0.62	0.63	0.64	0.65
	Med – High	CFM	1935	1909	1867	1836	1808	1766	1696	1619	1535	1454
		BHP	0.71	0.73	0.74	0.76	0.78	0.79	0.77	0.75	0.72	0.68
	High	CFM	2205	2150	2078	2011	1941	1852	1779	1672	1572	1473
		BHP	1.04	1.02	0.99	0.95	0.92	0.87	0.85	0.79	0.75	0.70

\* Air delivery values are without air filter and are for dry coil (See Wet Coil Pressure Drop Table).

<sup>1</sup> Factory – shipped cooling / heat pump heating speed

**NOTE:** Ducted field – supplied air filter pressure drop and wet coil pressure drop to obtain external static pressure available for ducting. Shaded areas indicate speed/static combinations that are not permitted for dehumidification speed.

### Dry Coil Air Delivery CFM\* - Horizontal Discharge Sizes 36-60 3-Phase Models Only

Unit	Motor Speed	Wire Color	CFM	External Static Pressure (IN. W.C.)									
				0.1	0.2	0.3	0.4	0.5	0.6	0.7	0.8	0.9	
36	Low	Blue	CFM	983	848	764	693	612	542	509	450	374	
	Med-Low	Pink	CFM	1008	901	838	757	693	618	550	532	471	
	Medium <sup>1</sup>	Red	CFM	1222	1236	1195	1148	1101	1052	1004	957	916	
	Med-High	Orange	CFM	1311	1242	1219	1161	1098	1032	969	907	841	
42	High	Black	CFM	1536	1470	1405	1333	1263	1204	1239	1181	1122	
	Low	Blue	CFM	952	882	806	746	671	605	530	551	486	
	Med-Low	Pink	CFM	1002	936	875	821	748	687	613	554	565	
	Medium	Red	CFM	1255	1210	1145	1074	1008	940	878	895	838	
48	Med-High <sup>1</sup>	Orange	CFM	1335	1267	1246	1176	1109	1049	988	926	872	
	High	Black	CFM	1472	1401	1326	1251	1275	1198	1139	1085	1023	
	Low	Blue	CFM	1402	1351	1311	1263	1224	1172	1136	1080	1041	
	Med-Low	Pink	CFM	1457	1404	1367	1318	1284	1233	1197	1144	1104	
60	Medium <sup>1</sup>	Red	CFM	1736	1695	1642	1601	1553	1512	1465	1427	1381	
	Med-High	Orange	CFM	2149	2111	2062	2026	1980	1945	1905	1864	1793	
	High	Black	CFM	2344	2306	2259	2203	2141	2070	1991	1902	1803	
	Low	Blue	CFM	1445	1389	1341	1281	1236	1189	1139	1072	1027	
60	Med-Low	Pink	CFM	1678	1635	1602	1558	1513	1474	1438	1404	1349	
	Medium <sup>1</sup>	Red	CFM	1962	1915	1880	1843	1794	1753	1711	1675	1628	
	Med-High	Orange	CFM	2131	2088	2065	2013	1982	1941	1888	1860	1785	
	High	Black	CFM	2461	2409	2339	2286	2192	2140	2062	1968	1874	

<sup>1</sup> Factory-shipped cooling / heat pump heating speed.

**NOTE:** Duct field-supplied air filter pressure drop and wet coil pressure drop to obtain external static pressure available for ducting.

Shaded areas indicate speed/static combinations that are not permitted for dehumidification speed.

**Dry Coil Air Delivery - Downflow Discharge - 36-60 3 Phase Models Only**

Unit	Motor Speed	Wire Color	External Static Pressure (IN. W.C.)											
			0.1	0.2	0.3	0.4	0.5	0.6	0.7	0.8	0.9	1.0		
36	Low	Blue	CFM	983	848	764	693	612	542	509	450	374	---	
			WATTS	115	107	113	123	128	138	144	154	159	---	
		Med-Low	Pink	BHP	0.12	0.11	0.12	0.13	0.14	0.15	0.15	0.17	0.17	---
				CFM	1008	901	838	757	693	618	550	532	471	402
			WATTS	123	121	132	137	148	154	164	170	181	185	
			BHP	0.13	0.13	0.14	0.15	0.16	0.17	0.18	0.18	0.19	0.20	
	Medium <sup>1</sup>	Red	CFM	1222	1236	1195	1148	1101	1052	1004	957	916	868	
			WATTS	233	221	232	244	251	264	275	285	291	304	
		Med-High	Orange	BHP	0.25	0.24	0.25	0.26	0.27	0.28	0.29	0.31	0.31	0.33
				CFM	1311	1242	1219	1161	1098	1032	969	907	841	859
			WATTS	256	270	283	289	301	313	320	331	343	349	
			BHP	0.27	0.29	0.30	0.31	0.32	0.34	0.34	0.35	0.37	0.37	
High	Black	CFM	1536	1470	1405	1333	1263	1204	1239	1181	1122	1055		
		WATTS	411	423	429	441	453	464	473	477	488	489		
	Low	Blue	BHP	0.44	0.45	0.46	0.47	0.49	0.50	0.51	0.51	0.52	0.52	
			CFM	952	882	806	746	671	605	530	551	486	435	
		WATTS	124	134	140	150	156	166	171	182	188	198		
		BHP	0.13	0.14	0.15	0.16	0.17	0.18	0.18	0.20	0.20	0.21		
Med-Low	Pink	CFM	1002	936	875	821	748	687	613	554	565	518		
		WATTS	144	155	161	171	176	187	193	203	209	220		
	Medium	Red	BHP	0.15	0.17	0.17	0.18	0.19	0.20	0.21	0.22	0.22	0.24	
			CFM	1255	1210	1145	1074	1008	940	878	895	838	785	
		WATTS	249	272	284	292	305	319	320	329	336	347		
		BHP	0.27	0.29	0.30	0.31	0.33	0.34	0.34	0.35	0.36	0.37		
Med-High <sup>1</sup>	Orange	CFM	1335	1267	1246	1176	1109	1049	988	926	872	891		
		WATTS	311	323	330	342	356	367	378	385	395	403		
	High	Black	BHP	0.33	0.35	0.35	0.37	0.38	0.39	0.41	0.41	0.42	0.43	
			CFM	1472	1401	1326	1251	1275	1198	1139	1085	1023	961	
		WATTS	401	414	426	440	471	462	473	478	486	491		
		BHP	0.43	0.44	0.46	0.47	0.51	0.50	0.51	0.51	0.52	0.53		

### Dry Coil Air Delivery - Downflow Discharge - Sizes 36-60 3 Phase Models Only (Cont.)

Unit	Motor Speed	Wire Color	External Static Pressure (IN. W.C.)										
			0.1	0.2	0.3	0.4	0.5	0.6	0.7	0.8	0.9	1.0	
48	Low	Blue	CFM	1503	1457	1423	1374	1330	1287	1241	1199	1153	1111
			WATTS	225	233	246	254	269	282	292	307	314	329
			BHP	0.24	0.25	0.26	0.27	0.29	0.30	0.31	0.33	0.34	0.35
	Med-Low	Pink	CFM	1556	1508	1461	1432	1388	1346	1302	1256	1221	1168
			WATTS	244	261	268	281	290	305	319	330	345	353
			BHP	0.26	0.28	0.29	0.30	0.31	0.33	0.34	0.35	0.37	0.38
	Medium <sup>1</sup>	Red	CFM	1861	1822	1786	1758	1716	1688	1660	1619	1583	1539
			WATTS	400	417	426	441	452	467	482	492	507	519
			BHP	0.43	0.45	0.46	0.47	0.48	0.50	0.52	0.53	0.54	0.56
	Med-High	Orange	CFM	2319	2291	2255	2230	2193	2166	2118	2057	1992	1887
			WATTS	758	769	787	799	808	823	822	805	780	737
			BHP	0.81	0.82	0.84	0.86	0.87	0.88	0.88	0.86	0.84	0.79
High	Black	CFM	2532	2487	2444	2391	2330	2259	2179	2111	2033	1949	
		WATTS	1014	1022	1015	994	965	935	898	858	823	786	
		BHP	1.09	1.10	1.09	1.07	1.03	1.00	0.96	0.92	0.88	0.84	
60	Low	Blue	CFM	1479	1436	1387	1346	1298	1253	1206	1160	1114	1061
			WATTS	224	239	247	262	270	284	300	307	319	330
			BHP	0.24	0.26	0.26	0.28	0.29	0.30	0.32	0.33	0.34	0.35
	Med-Low	Pink	CFM	1841	1796	1761	1724	1690	1651	1616	1578	1527	1478
			WATTS	425	434	453	460	476	485	501	508	525	542
			BHP	0.46	0.47	0.49	0.49	0.51	0.52	0.54	0.54	0.56	0.58
	Medium <sup>1</sup>	Red	CFM	1944	1913	1872	1838	1801	1771	1731	1698	1655	1613
			WATTS	486	501	511	529	537	554	565	578	595	603
			BHP	0.52	0.54	0.55	0.57	0.58	0.59	0.61	0.62	0.64	0.65
	Med-High	Orange	CFM	2178	2148	2105	2073	2036	2002	1967	1919	1845	1751
			WATTS	674	691	703	717	733	743	758	754	734	701
			BHP	0.72	0.74	0.75	0.77	0.79	0.80	0.81	0.81	0.79	0.75
High	Black	CFM	2480	2432	2375	2322	2236	2161	2085	2006	1917	1808	
		WATTS	1029	1012	995	975	941	908	869	836	796	751	
		BHP	1.10	1.09	1.07	1.05	1.01	0.97	0.93	0.90	0.85	0.81	

\*\* Air delivery values are without air filter and are for dry coil (See Wet Coil Pressure Drop table).

<sup>1</sup> Factory - shipped cooling / heat pump heating speed

Note: Duct field-supplied air filter pressure drop and wet coil pressure drop to obtain external static pressure available for ducting.

Shaded areas indicate speed/static combinations that are not permitted for dehumidification speed.

**PERFORMANCE DATA (CONT)**

**Filter Pressure Drop Table (IN. W.C.)**

FILTER SIZE IN. (MM)	COOLING TONS	STANDARD CFM (SCFM)																
		600	700	800	900	1000	1100	1200	1300	1400	1500	1600	1700	1800	1900	2000	2100	2200
600-1400 CFM 12x20x1+12x20x1 (305x508x25+305x508x25)	2.0,	0.03	0.04	0.05	0.06	0.06	0.07	0.07	0.08	0.08	-	-	-	-	-	-	-	-
	2.5																	
1200-1800CFM 16x24x1+14x24x1 (406x610x25+356x610x25)	3.0,	-	-	-	-	0.04	0.05	0.06	0.07	0.08	0.09	0.10	0.11	0.12	0.12	0.12	-	-
	3.5,																	
1500-2200CFM 16x24x1+18x24x1 (406x610x25+457x610x25)	4.0	-	-	-	-	-	-	-	-	-	0.04	0.06	0.08	0.10	0.11	0.13	0.14	0.15
	5.0																	

**Wet Coil Pressure Drop (IN. W.C.)**

UNIT SIZE	STANDARD CFM (SCFM)																
	600	700	800	900	1000	1100	1200	1300	1400	1500	1600	1700	1800	1900	2000	2100	2200
24	0.03	0.04	0.04	0.05	0.06	0.07	0.08	0.11									
30				0.05	0.06	0.07	0.08	0.11									
36				0.06	0.06	0.09	0.10	0.11	0.14								
42					0.05	0.05	0.06	0.07	0.08	0.08	0.09	0.09	0.11				
48							0.04	0.06	0.09	0.10	0.10	0.11	0.12	0.13	0.14		
60								0.06	0.06	0.07	0.07	0.08	0.08	0.09	0.10	0.12	0.13

**Economizer with 1-in. Filter Pressure Drop (IN. W.C.)**

FILTER SIZE IN. (MM)	COOLING TONS	STANDARD CFM (SCFM)																
		600	700	800	900	1000	1100	1200	1300	1400	1500	1600	1700	1800	1900	2000	2100	2200
600-1400 CFM 12x20x1+12x20x1 (305x508x25+305x508x25)	2.0,	-	-	0.08	0.09	0.10	0.10	0.11	0.11	0.11	0.14	-	-	-	-	-	-	-
	2.5																	
1200-1800CFM 16x24x1+14x24x1 (406x610x25+356x610x25)	3.0,	-	-	-	-	-	-	0.09	0.10	0.10	0.12	0.13	0.15	0.17	0.19	0.21	-	-
	3.5,																	
1500-2200CFM 16x24x1+18x24x1 (406x610x25+457x610x25)	4.0	-	-	-	-	-	-	0.06	0.09	0.10	0.10	0.11	0.12	0.13	0.14	0.14	0.14	0.15
	5.0																	

50VT

**PERFORMANCE DATA (CONT)**

**Electric Heat Pressure Drop Table (IN. W.C.)  
Small Cabinet: 24-30**

STATIC	STANDARD CFM (SCFM)															
	500	600	700	800	900	1000	1100	1200	1300	1400	1500	1600				
5kw	0.00	0.00	0.00	0.00	0.00	0.00	0.00	0.00	0.02	0.04	0.06	0.07				
7.5 kw	0.00	0.00	0.00	0.00	0.00	0.00	0.02	0.03	0.05	0.07	0.08	0.09				
10 kw	0.00	0.00	0.00	0.00	0.00	0.02	0.04	0.06	0.07	0.09	0.10	0.11				
15 kw	0.00	0.00	0.00	0.02	0.04	0.06	0.08	0.10	0.12	0.14	0.16	0.18				
20 kw	0.00	0.00	0.02	0.04	0.06	0.08	0.09	0.11	0.13	0.15	0.17	0.19				

**Electric Heat Pressure Drop Table (IN. W.C.)  
Large Cabinet 36-60**

STATIC	STANDARD CFM (SCFM)															
	1100	1200	1300	1400	1500	1600	1700	1800	1900	2000	2100	2200	2300	2400	2500	
5kw	0.00	0.00	0.00	0.01	0.02	0.03	0.04	0.05	0.06	0.07	0.08	0.09	0.10	0.11	0.12	
7.5 kw	0.00	0.00	0.01	0.02	0.03	0.04	0.05	0.06	0.07	0.08	0.09	0.10	0.11	0.12	0.13	
10 kw	0.00	0.00	0.01	0.02	0.03	0.04	0.05	0.06	0.07	0.08	0.09	0.10	0.11	0.12	0.13	
15 kw	0.00	0.02	0.03	0.04	0.05	0.06	0.07	0.08	0.09	0.10	0.11	0.12	0.13	0.14	0.15	
20 kw	0.02	0.03	0.04	0.05	0.06	0.07	0.08	0.09	0.10	0.11	0.12	0.13	0.14	0.15	0.16	

# TYPICAL PIPING AND WIRING

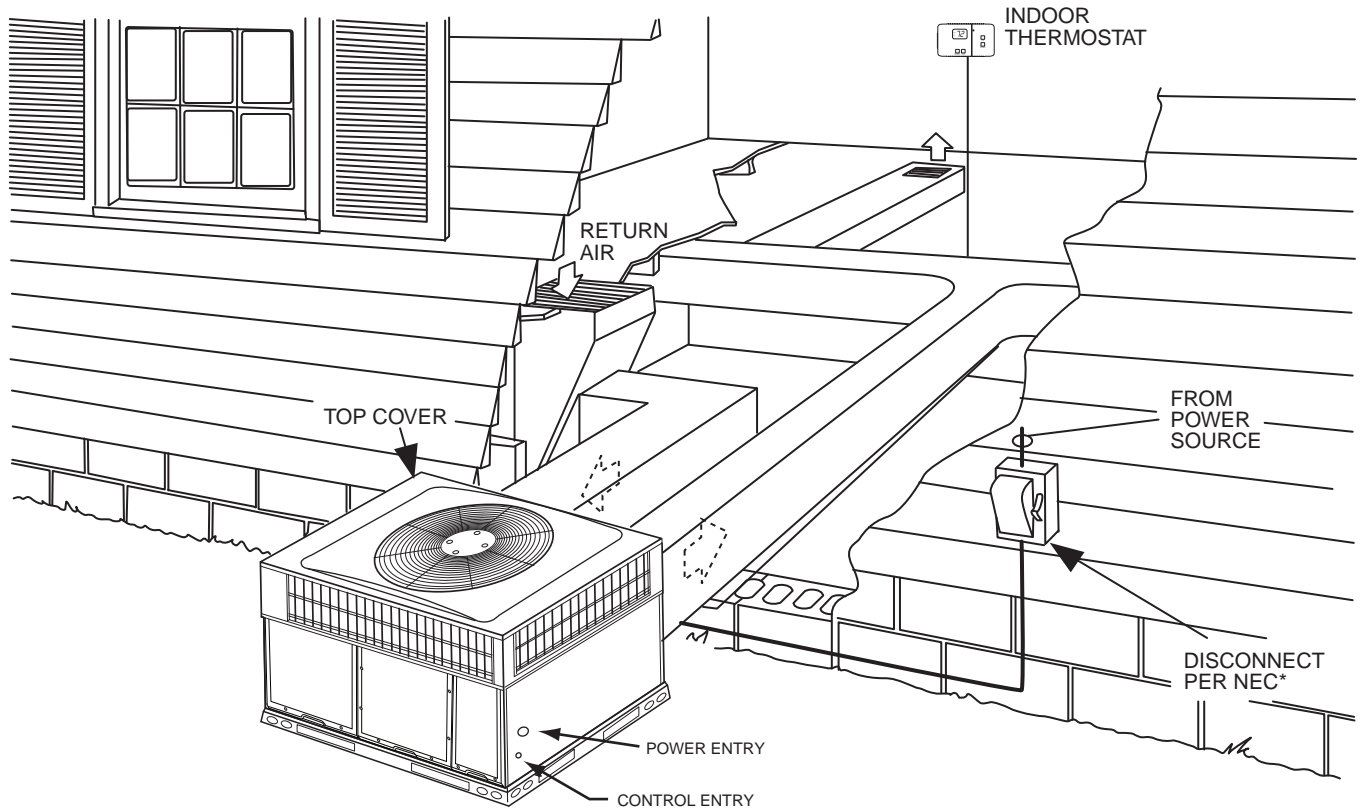

50VT

\*NEC - National Electrical Code  
A09240

## APPLICATION DATA

**Condensate trap** — A 2-in. (51 mm) condensate trap must be field supplied.

**Ductwork** — Secure downflow discharge ductwork to roof curb. For horizontal discharge applications, attach ductwork to unit with flanges.

**To convert a unit to downflow discharge** — Units are equipped with factory-installed inserts in the downflow openings. Removal of the inserts is similar to removing an electrical knock-out. Units installed in horizontal discharge orientation do not require duct covers.

**Maximum cooling airflow** — To minimize the possibility of condensate blow-off from the evaporator, airflow through the units should not exceed 450 CFM per ton.

**Minimum cooling airflow** — Minimum cooling airflow is 350 CFM per ton in cooling mode. Airflow can be lower in certain modes when humidity removal is an issue however, low airflow could result in indoor coil freezing and/or refrigerant floodback.

**Minimum ambient cooling operation temperature** — All standard units have a minimum ambient cooling operating temperature of 40°F (4.4°C). With accessory low ambient temperature kit, units can operate at temperatures down to 0°F (17.8°C).

**Maximum operating outdoor air temperature** for cooling is 125°F (51.7°C).

**BALANCE POINT WORKSHEET**

**BALANCE POINT WORKSHEET**

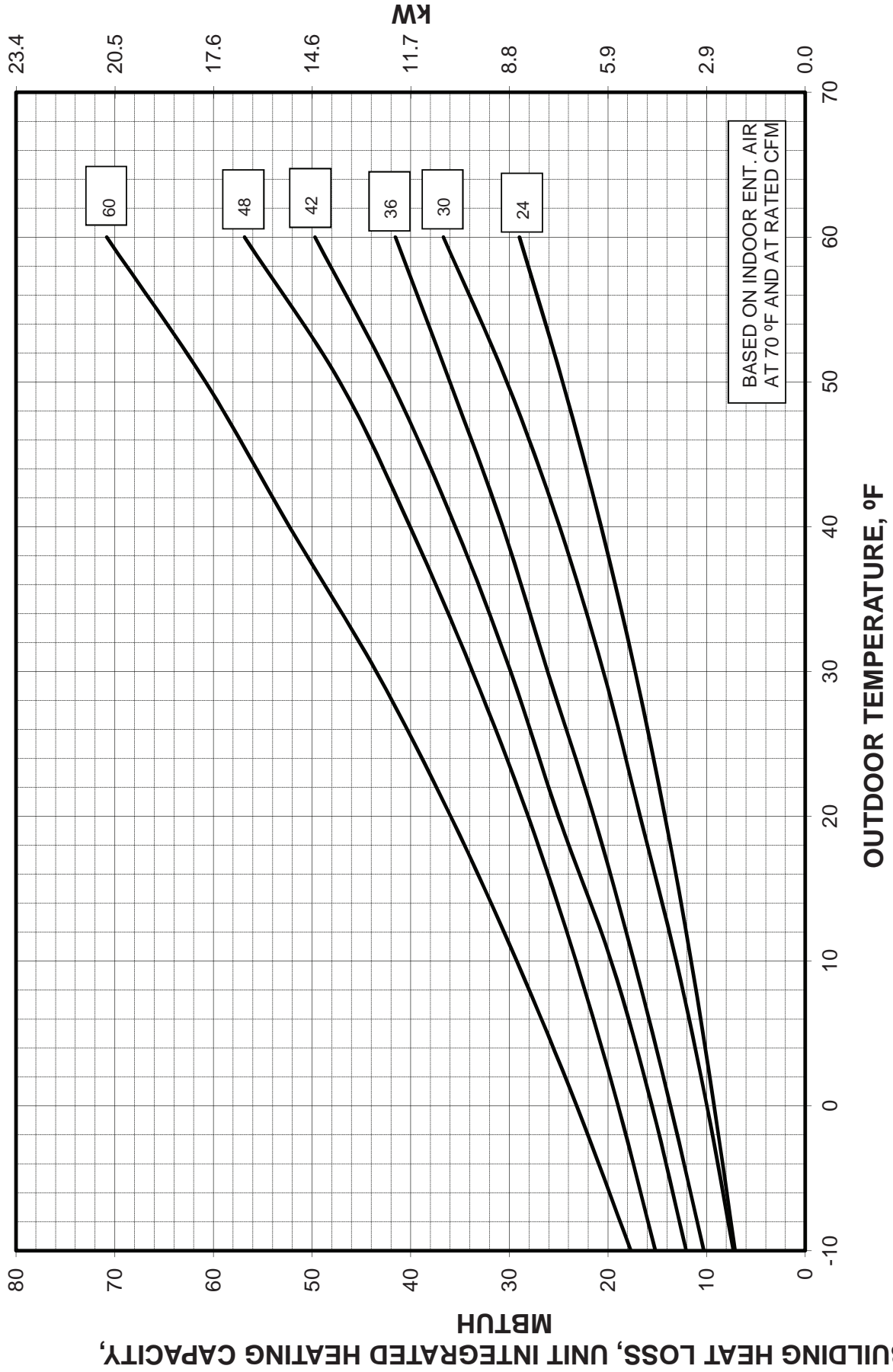

**50VT**

# ELECTRICAL DATA

50VT

MODEL	NOMINAL V-PH-HZ	VOLTAGE RANGE		COMPRESSOR		OFM	IFM	NOMINAL ELECTRIC HEAT	POWER SUPPLY		
		MIN	MAX	RLA	LRA	FLA	FLA		FLA	MCA	MOCP
24	208/230-1-60	197	253	13.5	58.3	0.6	3.8	-/-	-/-	21.3	30
								3.8/5	18.1/20.8	43.9/47.3	45/50
								5.4/7.2	25.9/30	53.7/58.8	60/60
								7.5/10	36.1/41.7	66.4/73.4	70/80
30	208/230-1-60	197	253	14.1	73	0.7	3.8	-/-	-/-	22.1	35
								3.8/5	18.1/20.8	44.8/48.1	45/50
								5.4/7.2	25.9/30	54.5/59.6	60/60
								7.5/10	36.1/41.7	67.3/74.3	70/80
36	208/230-1-60	197	253	16.7	79	1	3.8	11.3/15	54.2/62.5	89.9/100.3	90/110
								-/-	-/-	25.8	40
								3.8/5	18.1/20.8	48.4/51.7	50/60
								5.4/7.2	25.9/30	58.1/63.2	60/70
	208/230-3-60	197	253	10.4	73	1	4.1	7.5/10	36.1/41.7	70.9/77.9	80/80
								11.3/15	54.2/62.5	93.5/103.9	100/110
								-/-	-/-	18.2	25
								3.8/5	10.4/12	31.2/33.2	35/35
	460-3-60	414	506	5.8	38	0.5	3.2	7.5/10	20.8/24.1	44.2/48.3	45/50
								11.3/15	31.2/36.1	57.2/63.3	60/70
								-/-	-/-	11	15
								10	12	26	30
42	208/230-1-60	197	253	19.3	112	1	3.8	15	18	33.5	35
								-/-	-/-	29	45
								3.8/5	18.1/20.8	51.6/55	60/60
								5.4/7.2	25.9/30	61.4/66.5	70/70
	208/230-3-60	197	253	13.5	88	1	4.1	7.5/10	36.1/41.7	74.1/81.1	80/90
								11.3/15	54.2/62.5	96.7/107.1	100/110
								15/20	72.2/83.3	119.2/133.1	125/150
								-/-	-/-	22.1	35
	460-3-60	414	506	6	44	0.5	3.2	3.8/5	10.4/12	35/37	35/40
								7.5/10	20.8/24.1	48/52.2	50/60
								11.3/15	31.2/36.1	61/67.2	70/70
								15/20	41.4/47.9	73.8/81.9	80/90
48	208/230-1-60	197	253	19.6	130	1.1	7.6	-/-	-/-	11.2	15
								10	12	26.2	30
								15	18	33.7	35
								20	24.1	41.4	45
	208/230-3-60	197	253	13.7	83.1	1	7.6	-/-	-/-	33.2	50
								3.8/5	18.1/20.8	55.8/59.2	60/60
								5.4/7.2	25.9/30	65.5/70.7	70/80
								7.5/10	36.1/41.7	78.3/85.3	80/90
	460-3-60	414	506	6.2	41	0.5	4	11.3/15	54.2/62.5	100.9/111.3	110/125
								15/20	72.2/83.3	123.4/137.3	125/150
								-/-	-/-	25.8	35
								3.8/5	10.4/12	38.8/40.8	40/45
60	208/230-1-60	197	253	24.4	144.2	1.3	7.7	7.5/10	20.8/24.1	51.8/55.9	60/60
								11.3/15	31.2/36.1	64.8/70.9	70/80
								15/20	41.4/47.9	77.5/85.7	80/90
								-/-	-/-	12.3	15
	208/230-3-60	197	253	16	110	1	7.6	10	12	27.3	30
								15	18	34.8	35
								20	24.1	42.4	45
								-/-	-/-	39.5	60
	460-3-60	414	506	7.8	52	0.5	4	3.8/5	18.1/20.8	62.1/65.5	70/70
								5.4/7.2	25.9/30	71.9/77	80/80
								7.5/10	36.1/41.7	84.6/91.6	90/100
								11.3/15	54.2/62.5	107.3/117.6	110/125
								15/20	72.2/83.3	129.8/143.6	150/150
								-/-	-/-	28.7	40
								3.8/5	10.4/12	41.7/43.7	45/45
								7.5/10	20.8/24.1	54.7/58.8	60/60
								11.3/15	31.2/36.1	67.7/73.8	70/80
								15/20	41.4/47.9	80.4/88.5	90/90
								-/-	-/-	14.3	20
								10	12	29.3	30
								15	18	36.8	40
								20	24.1	44.4	45

See Legend and Notes.

LEGEND

- FLA - Full Load Amps
- IFM - Indoor Fan Motor
- LRA - Locked Rotor Amps
- MCA - Minimum Circuit Amps
- MOCP - Maximum Over Current Protection
- OFM - Outdoor Fan Motor
- RLA - Rated Load Amps

NOTES:

1. In compliance with NEC (National Electrical Code) requirements for multimotor and combination load equipment (refer to NEC Articles 430 and 440), the overcurrent protective device for the unit shall be Power Supply fuse or circuit breaker.
2. Minimum wire size is based on 60 C copper wire. If other than 60 C wire is used, or if length exceeds wire length in table, determine size from NEC.
3. Unbalanced 3-Phase Supply Voltage  
*Never operate a motor where a phase imbalance in supply voltage is greater than 2%.* Use the following formula to determine the percentage of voltage imbalance

$$\% \text{ Voltage imbalance} = 100 \times \frac{\text{max voltage deviation from average voltage}}{\text{average voltage}}$$

EXAMPLE: Supply voltage is 230-3-60.

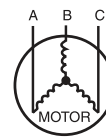

- AB = 228 v
- BC = 231 v
- AC = 227 v

$$\begin{aligned} \text{Average Voltage} &= \frac{228 + 231 + 227}{3} \\ &= \frac{686}{3} \\ &= 229 \end{aligned}$$

Determine maximum deviation from average voltage.

- (AB) 229 - 228 = 1 v
- (BC) 231 - 229 = 2 v
- (AC) 229 - 227 = 2 v

Maximum deviation is 2 v.

Determine percent of voltage imbalance

$$\begin{aligned} \% \text{ Voltage Imbalance} &= 100 \times \frac{2}{229} \\ &= 0.8\% \end{aligned}$$

This amount of phase imbalance is satisfactory as it is below the maximum allowable 2%.

**IMPORTANT:** If the supply voltage phase imbalance is more than 2%, contact your local electric utility company immediately.

A09604

50VT

# TYPICAL CONNECTION WIRING SCHEMATIC - 208/230-1-60

## CONNECTION WIRING DIAGRAM

**DANGER: ELECTRICAL SHOCK HAZARD DISCONNECT POWER BEFORE SERVICING**

### SCHEMATIC 208/230V-1-60

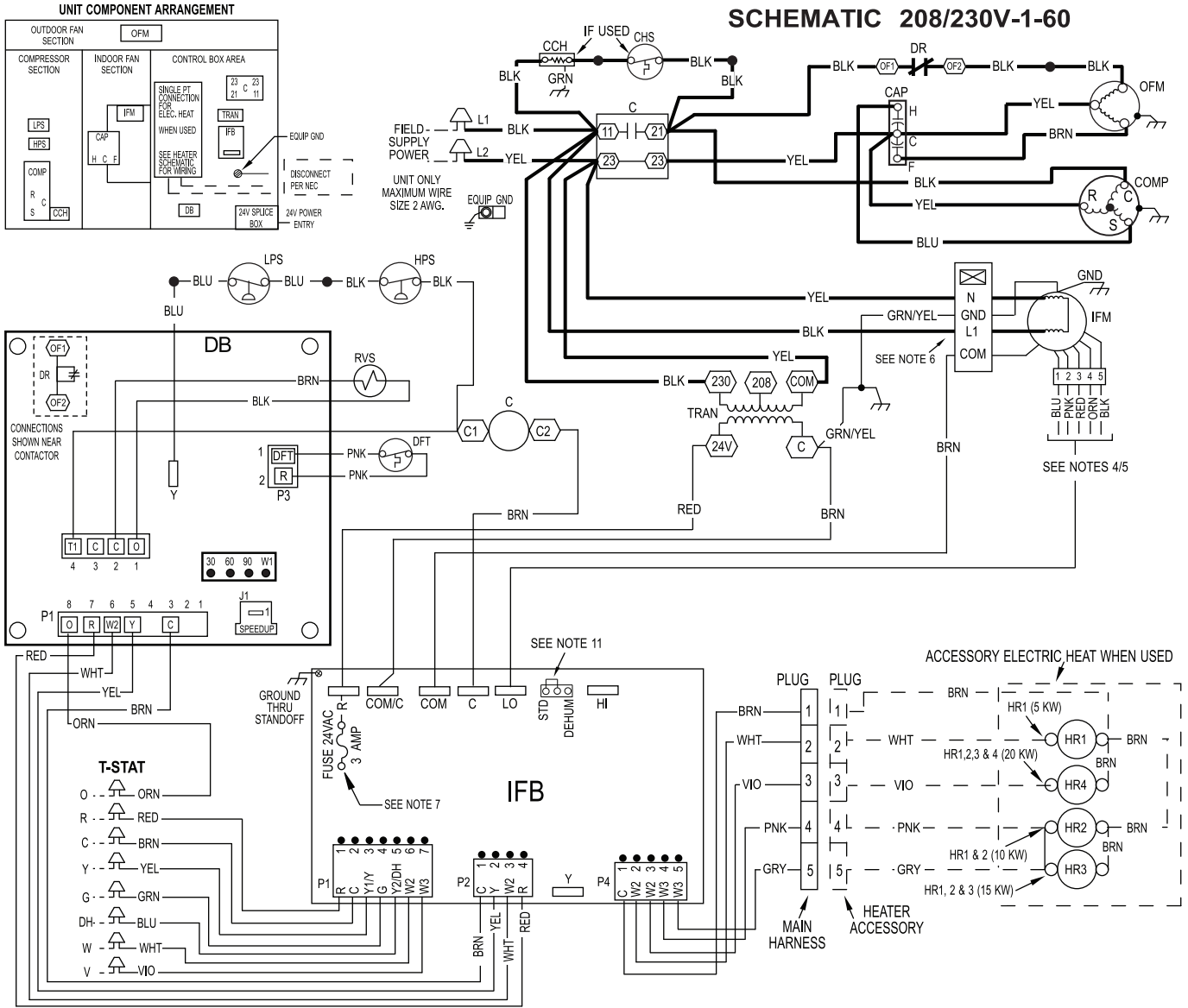

**50VT**

#### NOTES:

- IF ANY OF THE ORIGINAL WIRES FURNISHED ARE REPLACED IT MUST BE REPLACED WITH THE SAME OR ITS EQUIVALENT.
- SEE PRE SALE LITERATURE FOR THERMOSTATS.
- USE 75 DEGREES C COPPER CONDUCTORS FOR FIELD INSTALLATION.
- REFER TO INSTALLATION INSTRUCTIONS FOR CORRECT SPEED SELECTION FOR IFM.
- RELOCATION OF SPEED TAPS MAY BE REQUIRED WHEN USING FIELD INSTALLED ELECTRIC HEATERS. CONSULT INSTALLATION INSTRUCTIONS TO DETERMINE CORRECT SPEED TAP SETTING.
- "DO NOT DISCONNECT PLUG UNDER LOAD".
- THIS FUSE IS MANUFACTURED BY LITTLE FUSE, P/N 287003.
- N.E.C. CLASS 2, 24V.
- UNIT FACTORY - SHIPPED IN STD MODE.
- CCH NOT USED ON ALL UNITS.
- DEHUM FEATURE CANNOT BE USED WHEN ECONOMIZER IS INSTALLED. UNIT FACTORY - SHIPPED IN STD MODE.

#### LEGEND

	FIELD SPLICE		SPLICE		CONTACTOR		INDOOR FAN MOTOR
	TERMINAL (MARKED)		SPLICE (MARKED)		CAPACITOR		LOW PRESSURE SWITCH
	TERMINAL (UNMARKED)		FACTORY LO VOLTAGE		CRANKCASE HEATER		OUTDOOR FAN MOTOR
	SPLICE		FIELD CONTROL WIRING		COMPRESSOR MOTOR		REVERSING VALVE
	SPLICE (MARKED)		FIELD POWER WIRING		COMPRESSOR TIME DELAY		TRANSFORMER
	FACTORY LO VOLTAGE		ACCESSORY OR OPTIONAL WIRING		DEHUM		THERMOSTAT
	ACCESSORY OR OPTIONAL WIRING		FACTORY HI VOLTAGE		DEFROST BOARD		
	FACTORY HI VOLTAGE				DEFROST TEMPERATURE SWITCH		
	FACTORY HI VOLTAGE				DEFROST RELAY (SEE DB)		
	FACTORY HI VOLTAGE				GROUND		
	FACTORY HI VOLTAGE				HIGH PRESSURE SWITCH		
	FACTORY HI VOLTAGE				HEATER RELAY		
	FACTORY HI VOLTAGE				INDOOR FAN BOARD		

A150518

# TYPICAL LADDER WIRING SCHEMATIC - 208/230-1-60

## LADDER WIRING DIAGRAM

**DANGER: ELECTRICAL SHOCK HAZARD DISCONNECT POWER BEFORE SERVICING**

**DEFROST TIMING SELECTION**

FIELD SELECTABLE OPTIONS FOR TIME PERIOD BETWEEN DEFROST CYCLES (MINUTES). FACTORY DEFROST SETTING IS 60 MIN.

SPEED UP JUMPERED TEST PINS (USE METAL OBJECT) FIELD SPEED-UP CYCLE

1. DFT MUST BE CLOSED TO INITIATE DEFROST CYCLE. IF NECESSARY, REMOVE DFT CONNECTION BEFORE PLACING JUMPER ACROSS DFT PINS.
2. AT THE SAME TIME DFT CLOSED, JUMPER "SPEED UP" PINS WITH SMALL SCREW DRIVER UNTIL DEFROST IS INITIATED. THEN REMOVE SCREW DRIVER.
3. SHORTED "SPEED UP" PINS WILL SPEED UP TIMER BY A FACTOR OF 256.

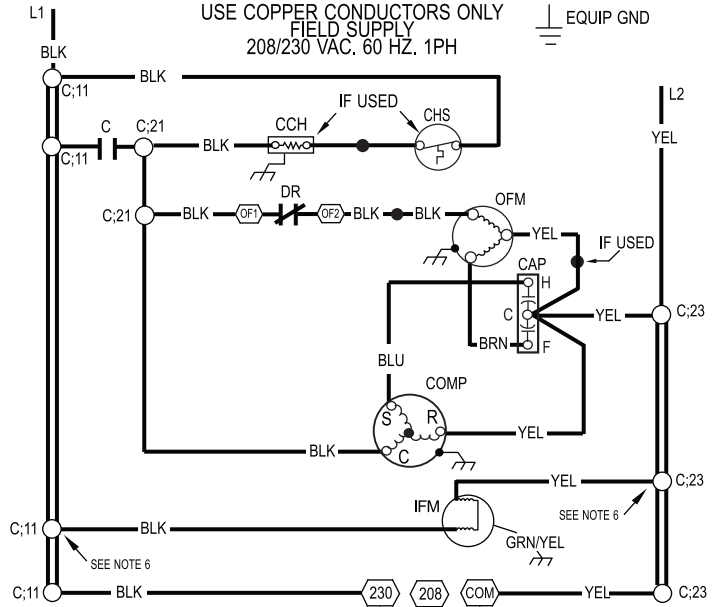

50VT

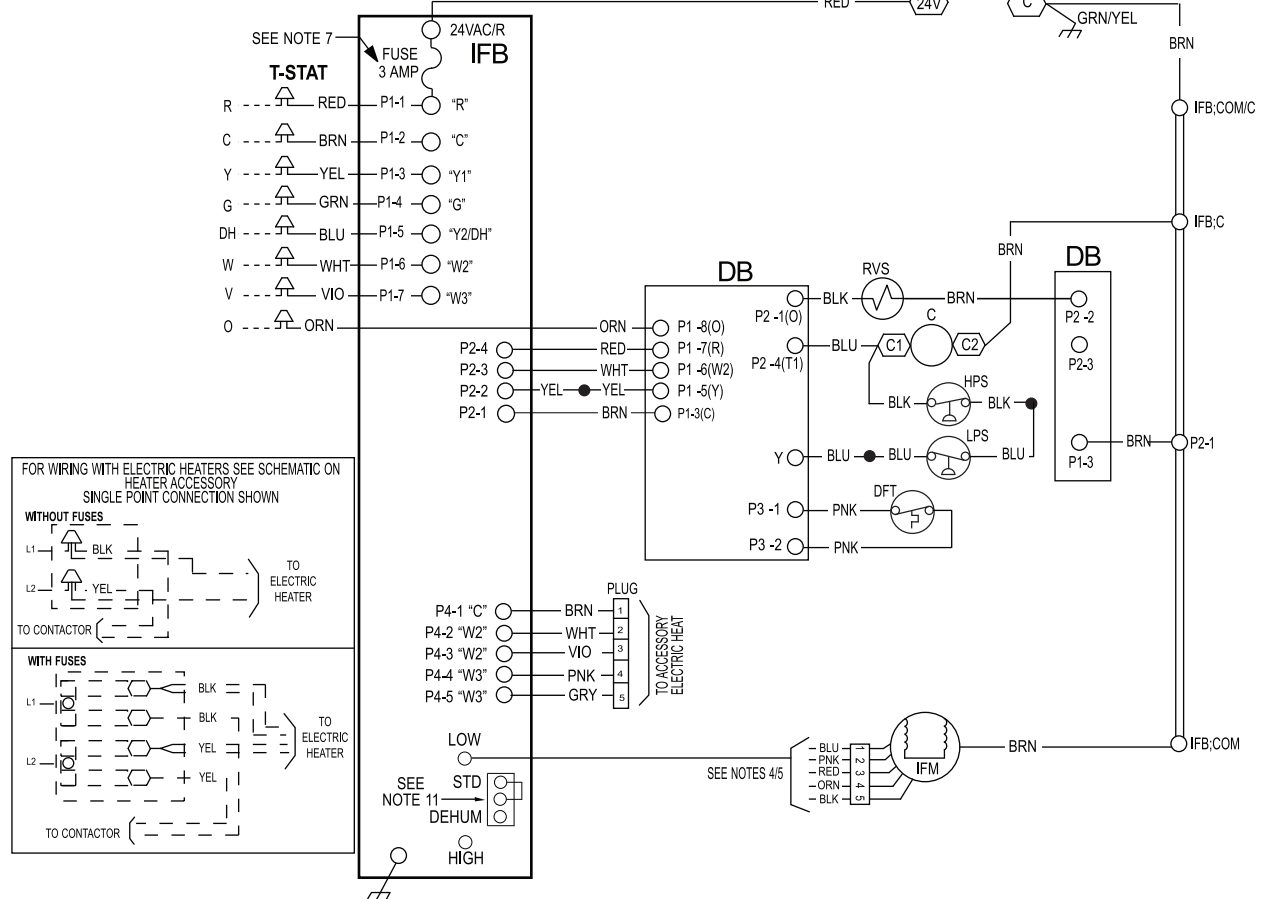

50VT500481 REV. -



50VT500481 REV. -

A150519

# TYPICAL CONNECTION WIRING SCHEMATIC - 208/230-3-60

## CONNECTION WIRING DIAGRAM DANGER: ELECTRICAL SHOCK HAZARD DISCONNECT POWER BEFORE SERVICING

### SCHEMATIC 208/230V-3-60

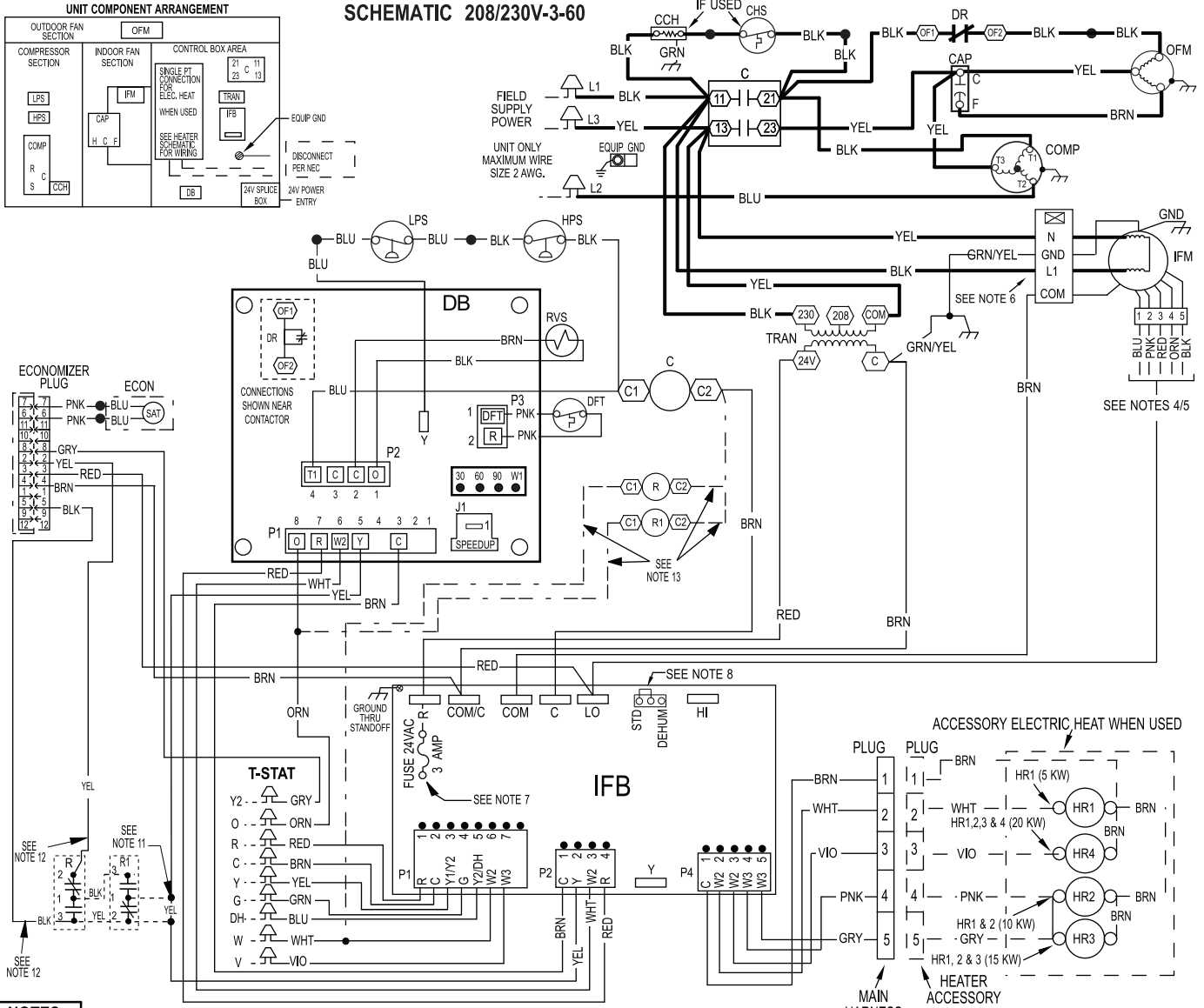

#### NOTES:

1. IF ANY OF THE ORIGINAL WIRES FURNISHED ARE REPLACED IT MUST BE REPLACED WITH THE SAME OR ITS EQUIVALENT.
2. SEE PRE SALE LITERATURE FOR THERMOSTATS.
3. USE 75 DEGREES C COPPER CONDUCTORS FOR FIELD INSTALLATION.
4. REFER TO INSTALLATION INSTRUCTIONS FOR CORRECT SPEED SELECTION FOR IFM.
5. RELOCATION OF SPEED TAPS MAY BE REQUIRED WHEN USING FIELD INSTALLED ELECTRIC HEATERS. CONSULT INSTALLATION INSTRUCTIONS TO DETERMINE CORRECT SPEED TAP SETTING.
6. "DO NOT DISCONNECT PLUG UNDER LOAD".
7. THIS FUSE IS MANUFACTURED BY LITTLE FUSE, P/N 287003.
8. DEHUM FEATURE CANNOT BE USED WHEN ECONOMIZER IS INSTALLED. UNIT FACTORY - SHIPPED IN STD MODE.
9. N.E.C. CLASS 2, 24V.
10. CCH NOT USED ON ALL UNITS.
11. REMOVE YELLOW SPLICE WHEN ECONOMIZER AND ECONOMIZER RELAYS ARE USED AND CONNECT TO RELAY R1 AS SHOWN.
12. WHEN ECONOMIZER AND ECONOMIZER RELAYS ARE USED CONNECT THE YELLOW AND BLACK WIRES TO RELAY "R" AS SHOWN. RELAY KIT REQUIRED WITH ECONOMIZER AND HEAT PUMP/DUAL FUEL UNITS.
13. WHEN ECONOMIZER AND ECONOMIZER RELAYS ARE USED, INSTALL WIRES AS SHOWN ONTO THE COILS OF RELAY R AND RELAY R1.

#### LEGEND

	FIELD SPLICE		C	CONTACTOR		HR	HEATER RELAY
	TERMINAL (MARKED)		CAP	CAPACITOR		IFB	INDOOR FAN BOARD
	TERMINAL (UNMARKED)		CCH	CRANK CASE HEATER		LPS	LOW PRESSURE SWITCH
	SPLICE		COMP	COMPRESSOR MOTOR		OFM	OUTDOOR FAN MOTOR
	SPLICE (MARKED)		DB	DEFROST BOARD		RVS	REVERSING VALVE
	FACTORY LO VOLTAGE		DFT	DEFROST TEMPERATURE SWITCH		STD	STANDARD MODE
	FIELD CONTROL WIRING		DEHUM	DEHUMIDIFICATION MODE		TRAN	TRANSFORMER
	FIELD POWER WIRING		DR	DEFROST RELAY (SEE DB)		ECON	ECONOMIZER
	ACCESSORY OR OPTIONAL WIRING		EQUIP	EQUIPMENT		GND	GROUND
	FACTORY HI VOLTAGE		HPS	HIGH PRESSURE SWITCH		T-STAT	THERMOSTAT

A150520

# TYPICAL LADDER WIRING SCHEMATIC - 208/230-3-60

## LADDER WIRING DIAGRAM

**DANGER: ELECTRICAL SHOCK HAZARD DISCONNECT POWER BEFORE SERVICING**

**DEFROST TIMING SELECTION**

FIELD SELECTABLE OPTIONS FOR TIME PERIOD BETWEEN DEFROST CYCLES (MINUTES). FACTORY DEFROST SETTING IS 60 MIN.

SPEED UP JUMPERS (USE METAL OBJECT) FIELD SPEED-UP CYCLE

- DFT MUST BE CLOSED TO INITIATE DEFROST CYCLE. IF NECESSARY, REMOVE DFT CONNECTION BEFORE PLACING JUMPER ACROSS DFT PINS.
- AT THE SAME TIME DFT CLOSED, JUMPER "SPEED UP" PINS WITH SMALL SCREW DRIVER UNTIL DEFROST IS INITIATED. THEN REMOVE SCREW DRIVER.
- SHORTED "SPEED UP" PINS WILL SPEED UP TIMER BY A FACTOR OF 256.

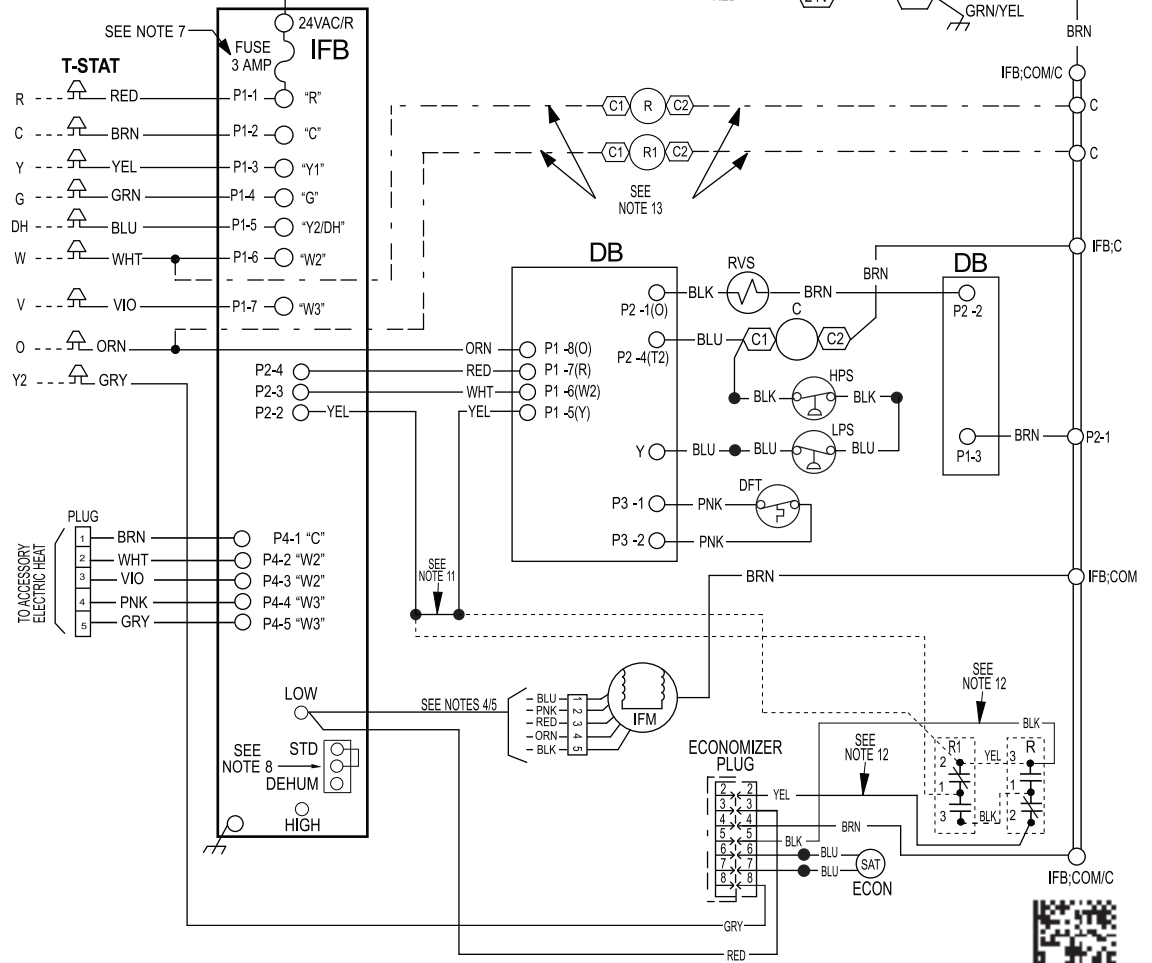
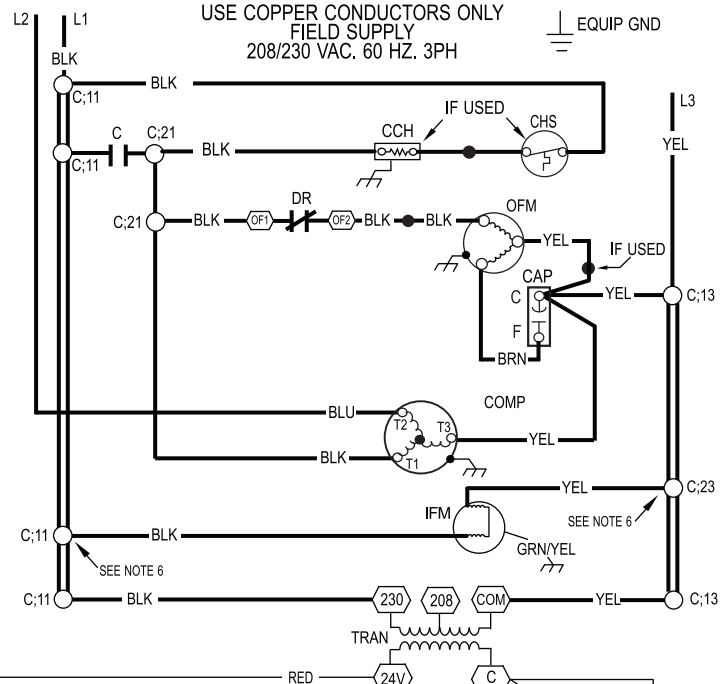
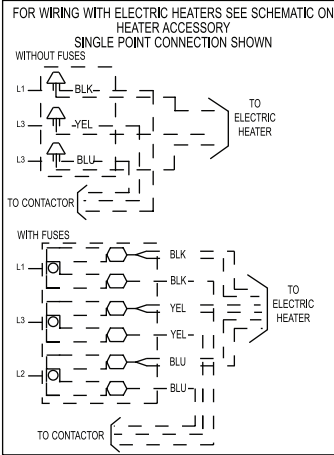

50VT

50VT500482 REV. -





# TYPICAL LADDER WIRING SCHEMATIC - 460-3-60

## LADDER WIRING DIAGRAM

**DANGER: ELECTRICAL SHOCK HAZARD DISCONNECT POWER BEFORE SERVICING**

**DEFROST TIMING SELECTION**

FIELD SELECTABLE OPTIONS FOR TIME PERIOD BETWEEN DEFROST CYCLES (MINUTES)  
FACTORY DEFROST SETTING IS 60 MIN.

SPEED UP   JUMPERED TEST PINS (USE METAL OBJECT) FIELD SPEED-UP CYCLE

- DFT MUST BE CLOSED TO INITIATE DEFROST CYCLE. IF NECESSARY, REMOVE DFT CONNECTION BEFORE PLACING JUMPER ACROSS DFT PINS.
- AT THE SAME TIME DFT CLOSED, JUMPER "SPEED UP" PINS WITH SMALL SCREW DRIVER UNTIL DEFROST IS INITIATED. THEN REMOVE SCREW DRIVER.
- SHORTED "SPEED UP" PINS WILL SPEED UP TIMER BY A FACTOR OF 256.

**FOR WIRING WITH ELECTRIC HEATERS SEE SCHEMATIC ON HEATER ACCESSORY**

SINGLE POINT CONNECTION SHOWN

WITHOUT FUSES

TO ELECTRIC HEATER

TO CONTACTOR

WITH FUSES

TO ELECTRIC HEATER

TO CONTACTOR

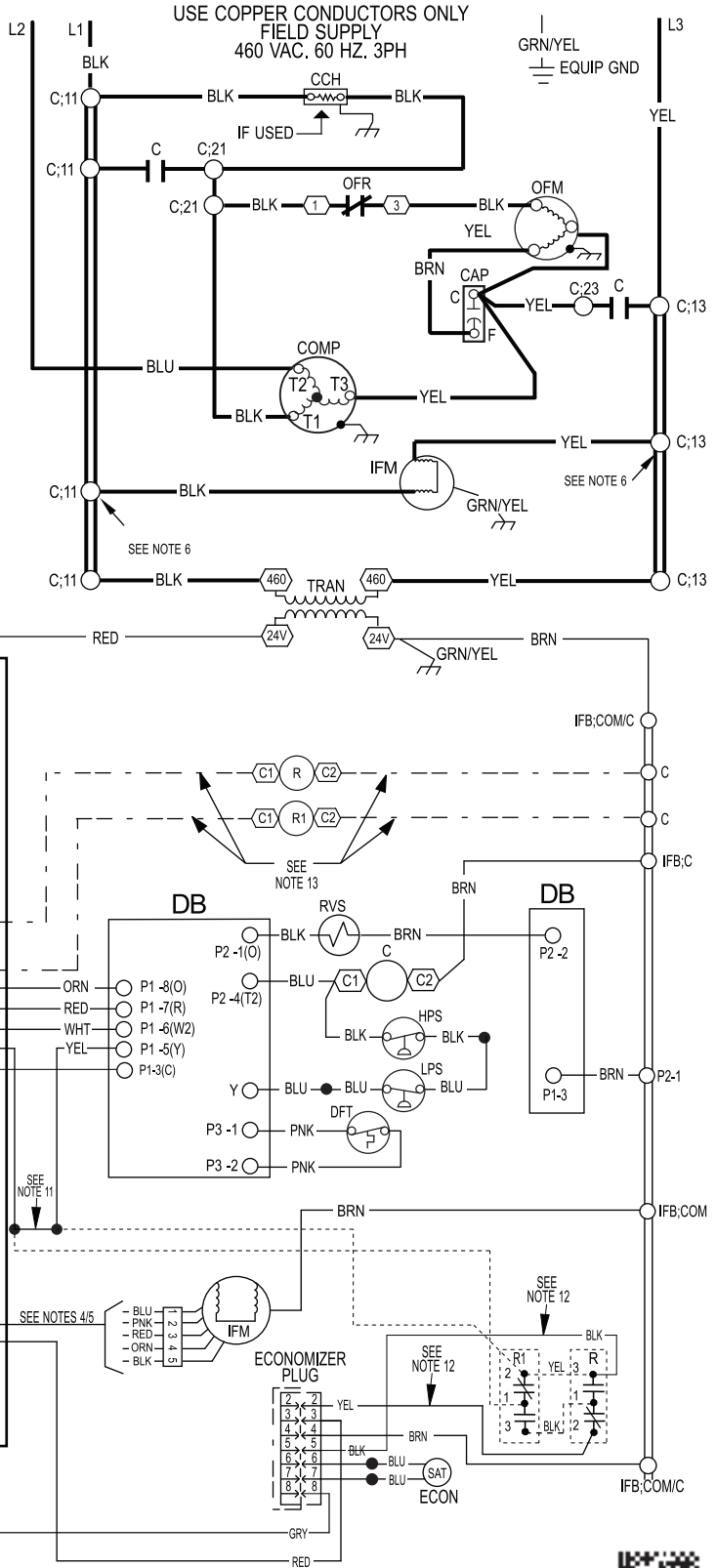

50VT

50VT500484 REV. -



A150523

## CONTROLS

### Operating sequence

When power is supplied to unit, the transformer (TRAN) is energized.

On units with crankcase heater, heater is also energized.

**Cooling** — With the thermostat in the cooling position, the thermostat makes circuit R-O. This energizes the reversing valve solenoid (RVS) and places the unit in standby condition for cooling.

As the space temperature rises, the thermostat closes circuit R-Y. A circuit is made to contactor (C), starting the compressor (COMP) and outdoor-fan motor (OFM). Circuit R-G is made at the same time and starts the indoor-fan motor (IFM).

When the thermostat is satisfied, contacts open, deenergizing C. The COMP and OFM stop, and the IFM stops after the preselected time delay.

**Heating** — On a call for heat, thermostat makes circuits R-Y and R-G.

A circuit is made to C, starting COMP and OFM. Circuit R-G also is completed, energizing IFR and starting IFM after the selected time delay.

Should room temperature continue to fall, circuit R-W is made through second-stage thermostat. If optional electric heat package is used, a relay is energized, bringing on first bank of supplemental electric heat. When thermostat is satisfied, contacts open, deenergizing contactor and relay; motors and heaters deenergize.

**Defrost** — Defrost board (DB) is a time and temperature control, which includes a field-selectable time period (dip switch 1 and 2 on the board) between checks for defrost (30, 60, 90, or 120 minutes). Electronic timer and defrost cycle start only when contactor is energized and defrost thermostat (DFT) is closed.

The defrost board is also equipped with a third dip switch for selecting Quiet Shift operation. The Quiet Shift operation turns compressor off at defrost initiation and termination. Unit is factory shipped with quiet shift turned off.

Defrost mode is identical to cooling mode, except outdoor fan motor stops and a bank of optional electric heat turns on to warm air supplying the conditioned space.

#### NOTE:

1. Compressor time delay occurs through the defrost control board.
2. Defrost control board has built in 5 minute compressor delay; once the compressor has started and then stopped, it cannot be restarted again until 5 minutes have elapsed.

# GUIDE SPECIFICATIONS

## Packaged Heat Pump System

### HVAC Guide Specifications

Size Range: 2 to 5 Tons, Nominal Cooling

#### Part 1—General

#### SYSTEM DESCRIPTION

Outdoor, packaged, air-to-air heat pump unit utilizing a hermetic scroll compressor for cooling duty and optional electric heating. Unit shall discharge supply air vertically or horizontally as shown on contract drawings. Outdoor fan/coil section shall have a draw-thru design with vertical discharge for minimum sound levels.

#### QUALITY ASSURANCE

- A. Unit shall be rated in accordance with AHRI Standards 210/240 and 270.
- B. Unit shall be designed in accordance with UL Standard 1995.
- C. Unit shall be manufactured in a facility registered to ISO 9001 manufacturing quality standard.
- D. Unit shall be UL listed and c-UL certified as a total package for safety requirements.
- E. Roof curb shall be designed to conform to NRCA Standards.
- F. Insulation and adhesives shall meet NFPA 90A requirements for flame spread and smoke generation.
- G. Cabinet insulation shall meet ASHRAE Standard 62P.

#### DELIVERY, STORAGE AND HANDLING

Unit shall be stored and handled per manufacturer's recommendations.

#### Part 2—Products

#### EQUIPMENT

##### A. General:

Factory-assembled, single-piece, heat pump unit. Contained within the enclosure shall be all factory wiring, piping, controls, refrigerant charge (R-410A), and special features required prior to field start-up.

##### B. Unit Cabinet:

- 1. Unit cabinet shall be constructed of phosphated, zinc-coated, pre-painted steel capable of withstanding 500 hours of salt spray.
- 2. Normal service shall be through 3 removable cabinet panels.
- 3. The unit shall be constructed on a rust proof unit base that has an externally trapped, integrated sloped drain.
- 4. Indoor fan compartment top surface shall be insulated with a minimum 1/2-in. (13 mm) thick, flexible fiberglass insulation, coated on the air side and retained by adhesive and mechanical means. The indoor wall sections will be insulated with a minimum semi-rigid, foil-faced board capable of being wiped clean. Aluminum foil-faced fiberglass insulation shall be used in the entire indoor air cavity section.
- 5. Unit shall have a field-supplied condensate trap.
- 6. Metal Insulated Duct Covers for side discharge will be standard on all sizes.
- 7. Unit insulation conforms to ASHRAE 62P.

##### C. Fans:

- 1. The indoor fan shall be 5-speed, direct-drive, as shown on equipment drawings.
- 2. Fan wheel shall be made from steel and shall be double-inlet type with forward-curved blades with

corrosion resistant finish. Fan wheel shall be dynamically balanced.

- 3. Outdoor fan shall be direct-drive, propeller-type with aluminum blades riveted to corrosion resistant steel spiders, be dynamically balanced, and discharge air vertically.

##### D. Compressor:

- 1. Fully hermetic compressors with factory-installed vibration isolation.
- 2. Scroll compressors shall be standard on all units.

##### E. Coils:

Indoor and outdoor coils shall have aluminum plate fins mechanically bonded to seamless copper tubes with all joints brazed. Tube sheet openings shall be belled to prevent tube wear.

##### F. Refrigerant Metering Device:

Refrigerant metering device shall be thermostatic expansion valve or fixed orifice for cooling, and fixed orifice for heating.

##### G. Filters:

Filter section shall consist of field-installed, throwaway, 1-in. (25 mm) - thick fiberglass filters of commercially available sizes.

##### H. Controls and Safeties:

- 1. Unit controls shall be complete with a self-contained, low-voltage control circuit.
- 2. Units shall incorporate an internal compressor protector that provides reset capability.

##### I. Operating Characteristics:

- 1. Unit shall be capable of starting and running at 125°F (51.7°C) ambient outdoor temperature.
- 2. Compressor with standard controls shall be capable of operation down to 40°F (4.4°C) ambient outdoor temperature in cooling mode.
- 3. Unit shall be provided with 90-second fan time delay after the thermostat is satisfied.

##### J. Electrical Requirements:

All unit power wiring shall enter the unit cabinet at a single location.

##### K. Motors:

- 1. Compressor motors shall be of the refrigerant-cooled type with line-break thermal and current overload protection.
- 2. All fan motors shall have permanently lubricated bearings, and inherent, automatic reset, thermal overload protection.
- 3. Condenser fan motor shall be totally enclosed.
- 4. Evaporator fan motor to be ECM Motor.

##### L. Special Features Available:

- 1. Coil Options:  
Base unit with tin plated indoor coil hairpins available as a factory installed option.
- 2. Compressor Start Kit (single phase units only):  
Shall provide additional starting torque for single-phase compressors.

## GUIDE SPECIFICATIONS (CONT)

3. Thermostat:  
To provide for two-stage heating and one-stage cooling in addition manual or automatic changeover and indoor fan control.
4. Crankcase Heater:  
Shall provide anti-floodback protection for lowload cooling applications.
5. Economizer:  
(Horizontal - Field installed accessory)  
(Vertical - Field installed accessory)
  - a. Economizer controls capable of providing free cooling using outside air.
  - b. Equipped with low leakage dampers not to exceed 3% leakage, at 1.0 IN. W.C. pressure differential.
  - c. Spring return motor shuts off outdoor damper on power failure.
6. Electric Heaters
  - a. Electric heater shall be available as a field installed option.
  - b. Heater elements shall be open wire type, adequately supported and insulated with ceramic bushings.
  - c. Electric heater packages must provide single point power connection capability.
7. Filter Rack Kit:  
Shall provide filter mounting for downflow applications. Offered as a field installed accessory.
8. Flat Roof Curb:  
Curbs shall have seal strip and a wood nailer for flashing and shall be installed per manufacturer's instructions.
9. Low Ambient Package:  
Shall consist of a solid-state control and outdoor coil temperature sensor for controlling outdoor-fan motor operation, which shall allow unit to operate down to 0°F (-17.7°C) outdoor ambient temperature.
10. Manual Outdoor Air Damper:  
Package shall consist of damper, birdscreen, and rainhood which can be preset to admit outdoor air for year-round ventilation.
11. Square-To-Round Duct Transitions (24-48 size):  
Shall have the ability to convert the supply and return openings from rectangular to round.
12. Time Guard II  
Automatically prevents the compressor from restarting for at least 4 minutes and 45 seconds after shutdown of the compressor. Not required when a corporate programmable thermostat is applied or with a RTU-MP control. Offered as a field installed accessory.
13. Dual Point Electric Heaters|  
Allows you to power the electric heater and unit contactor separately by having two individual field power supply circuits connected respectively.
14. Cabinet air leakage of 2.0% or less at .5 in. W.C. when tested in accordance with ASHRAE standard 193. Available as a factory installed option.
15. Louver Metal Outdoor Coil Grille  
Shall provide hail and vandalism protection. Available as a field installed accessory.



