

**50VL-C, 50VL-F
 Comfort™ 14 SEER Single-Packaged Air
 Conditioner System with Puron®
 (R-410A) Refrigerant
 Single Phase 2-5 Nominal Tons (Sizes 24-60)
 Three Phase 3-5 Nominal Tons (Sizes 36-60)**



Turn to the experts

Installation Instructions

IMPORTANT: Effective January 1, 2015, all split system and packaged air conditioners must be installed pursuant to applicable regional efficiency standards issued by the Department of Energy.

NOTE: Read the entire instruction manual before starting the installation.

NOTE: Installer: Make sure the Owner's Manual and Service Instructions are left with the unit after installation.

Table of Contents

Safety Considerations	1
Introduction	2
Receiving and Installation	2
Pre-Start-up	11
Start-up	11
Maintenance	28
Troubleshooting	31
Start-up Checklist	31

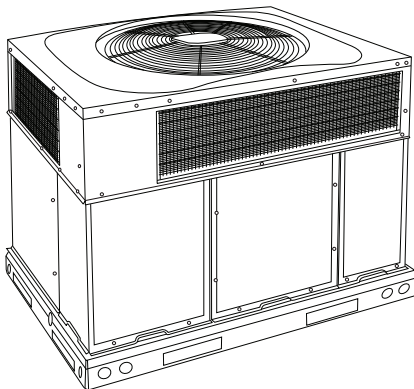

A170030

Fig. 1 – Unit 50VL

Safety Considerations

Improper installation adjustment, alteration, service, maintenance, or use can cause explosion, fire, electrical shock, or other conditions which may cause death, personal injury, or property damage. Consult a qualified installer, service agency, or your distributor or branch for information or assistance. The qualified installer or agency must use factory-authorized kits or accessories when modifying this product Refer to the individual instructions packaged with the kits or accessories when installing.

Follow all safety codes. Wear safety glasses, protective clothing, and work gloves. Use quenching cloth for brazing operations. Have a fire extinguisher available. Read these instructions thoroughly and follow all warnings or cautions included in literature and attached to the unit.

Consult local building codes, the current editions of the National Electrical Code (NEC) NFPA 70.

In Canada refer to the current editions of the Canadian electrical Code CSA C22.1.

Recognize safety information. This is the safety-alert symbol . When you see this symbol on the unit and in instructions or manuals, be alert to the potential for personal injury. Understand these signal words; DANGER, WARNING, and CAUTION. These words are used with the safety-alert symbol. DANGER identifies the most serious hazards which will result in severe personal injury or death. WARNING signifies hazards which could result in personal injury or death. CAUTION is used to identify unsafe practices which may result in minor personal injury or product and property damage. NOTE is used to highlight suggestions which will result in enhanced installation, reliability, or operation.

WARNING

ELECTRICAL SHOCK HAZARD

Failure to follow this warning could result in personal injury or death. Before installing or servicing system, always turn off main power to system and install lockout tag. There may be more than one disconnect switch. Turn off accessory heater power switch if applicable.

WARNING

PERSONAL INJURY AND ENVIRONMENTAL HAZARD

Failure to relieve system pressure could result in personal injury and/or death.

1. Relieve pressure and recover all refrigerant before servicing existing equipment, and before final unit disposal. Use all service ports and open all flow-control devices, including solenoid valves.
2. Federal regulations require that you do not vent refrigerant into the atmosphere. Recover during system repair or final unit disposal.

! CAUTION

CUT HAZARD

Failure to follow this caution may result in personal injury. When removing access panels (see Fig. 22) or performing maintenance functions inside your unit, be aware of sharp sheet metal parts and screws. Although special care is taken to reduce sharp edges to a minimum, be extremely careful and wear appropriate clothing, safety glasses and gloves when handling parts or reaching into the unit.

Introduction

This packaged air conditioner is fully self-contained and designed for outdoor installation (See Fig. 1). See Fig. 2 and Fig. 3 for unit dimensions. All unit sizes have discharge openings for both horizontal and downflow configurations, and are factory shipped with all downflow duct openings covered. The unit may be installed either on a rooftop or on a ground-level cement slab. (See Fig. 4 for roof curb dimensions.)

Receiving and Installation

Step 1 – Check Equipment

Identify Unit

The unit model number and serial number are printed on the unit informative plate. Check this information against shipping papers.

Inspect Shipment

Inspect for shipping damage before removing packaging materials. If unit appears to be damaged or is torn loose from its anchorage, have it examined by transportation inspectors before removal. Forward claim papers directly to transportation company. Manufacturer is not responsible for any damage incurred in transit. Check all items against shipping list. Immediately notify the nearest equipment distribution office if any item is missing. To prevent loss or damage, leave all parts in original packages until installation.

If the unit is to be mounted on a curb in a downflow application, review Step 7 to determine which method is to be used to remove the downflow panels before rigging and lifting into place. The panel removal process may require the unit to be on the ground.

Step 2 – Provide Unit Support

IMPORTANT: The unit must be secured to the curb by installing screws through the bottom of the curb flange and into the unit base rails. When installing large base units onto the common curb, the screws must be installed before allowing the full weight of the unit to rest on the curb. A minimum of six screws are required for large base units. Failure to secure unit properly could result in an unstable unit. See Warning near Rigging/Lifting information and accessory curb instructions for more details.

For hurricane tie downs, contact distributor for details and PE (Professional Engineering) Certificate if required.

Roof Curb

Install accessory roof curb in accordance with instructions shipped with curb (See Fig. 4). Install insulation, cant strips, roofing, and flashing. Ductwork must be attached to curb.

IMPORTANT: The gasketing of the unit to the roof curb is critical for a water tight seal. Install gasketing material supplied with the roof curb. Improperly applied gasketing also can result in air leaks and poor unit performance.

Curb should be level to within 1/4 in. (6.35 mm) (See Fig. 4). This is necessary for unit drain to function properly. Refer to accessory roof curb installation instructions for additional information as required.

Installation on older “G” series roof curbs.

Two accessory kits are available to aid in installing a new “G” series unit on an old “G” roof curb.

1. Accessory kit number CPADCURB001A00, (small chassis) and accessory kit number CPADCURB002A00, (large chassis) includes roof curb adapter and gaskets for the perimeter seal and duct openings. No additional modifications to the curb are required when using this kit.
2. An alternative to the adapter curb is to modify the existing curb by removing the outer horizontal flange and use accessory kit number CPGSKTKIT001A00 which includes spacer blocks (for easy alignment to existing curb) and gaskets for the perimeter seal and duct openings. This kit is used when existing curb is modified by removing outer horizontal flange.

! CAUTION

UNIT/STRUCTURAL DAMAGE HAZARD

Failure to follow this caution may result in property damage. Ensure there is sufficient clearance for saw blade when cutting the outer horizontal flange of the roof curb so there is no damage to the roof or flashing.

Slab Mount

Place the unit on a solid, level pad that is at least 2 in. (51 mm) above grade. The pad should extend approximately 2 in. (51 mm) beyond the casing on all 4 sides of the unit (See Fig. 7). Do not secure the unit to the pad except when required by local codes.

UNIT	ELECTRICAL CHARACTERISTICS	UNIT WT.		UNIT HEIGHT IN/MM		CENTER OF GRAVITY IN/MM					
		LB	KG	A"	Z	X	Z				
50VL-C24---30	208/230-1-60	304	138.0	43-3/4	1111	20-1/2	520.7	15-3/4	400.1	16-5/8	422.3
50VL-F30---30	208/230-1-60	320	145.0	45-3/4	1162	20-1/2	520.7	15-3/4	400.1	16-5/8	422.3
50VL-C36---(375/610)	208/230-1-60, 208/230-3-60, 460-3-60	349	158.0	51-3/4	1315	20-1/2	520.7	15-3/4	400.1	17-3/8	441.3

UNIT	VOLTAGE	CORNER WEIGHT LB/KG		
		1"	2"	3"
24	208/230	45.6	20.7	60.8
30	208/230	48.0	21.7	64.0
36	208/230/460	52.4	23.7	69.8

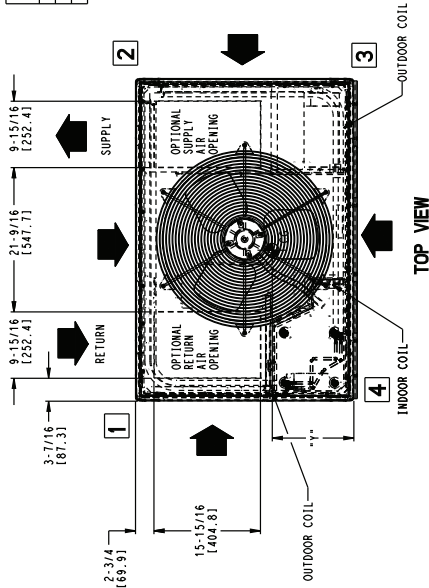

REQUIRED CLEARANCES TO COMBUSTIBLE UNIT.

	INCHES (MM)
TOP OF UNIT.....	14 (355.8)
DRY SIDE OF UNIT.....	14 (355.8)
WET SIDE OF UNIT.....	14 (355.8)
SIDE OPPOSITE DUCTS.....	14 (355.8)
BOTTOM OF UNIT.....	0 (0.0)
ELECTRICAL PANEL.....	36 (914.4)

NEC REQUIRED CLEARANCES

	INCHES (MM)
BETWEEN UNITS, POWER ENTRY SIDE.....	42 (1066.8)
UNIT AND UNGROUND SURFACES, POWER ENTRY SIDE.....	36 (914.0)
BETWEEN UNITS, COMPRESSOR OTHER GROUND SURFACES, POWER ENTRY SIDE.....	42 (1066.8)

EMVP COIL ACCESS SIDE

	INCHES (MM)
POWER ENTRY SIDE.....	36 (914.0)
POWER ENTRY SIDE, EXCEPT FOR NEC REQUIREMENTS.....	42 (1066.8)
UNIT TOP (FOR NEC REQUIREMENTS).....	48 (1219.2)
UNIT TOP (FOR NEC REQUIREMENTS).....	48 (1219.2)
UNIT TOP (FOR NEC REQUIREMENTS).....	48 (1219.2)
DUCT PANEL.....	12 (304.8)

*MINIMUM DISTANCES: IF UNIT IS PLACED LESS THAN 12 (304.8) FROM WALL SYSTEM, THEN SYSTEM PERFORMANCE MAYBE COMPROMISED.

DIMENSIONS IN () ARE IN MILLIMETERS

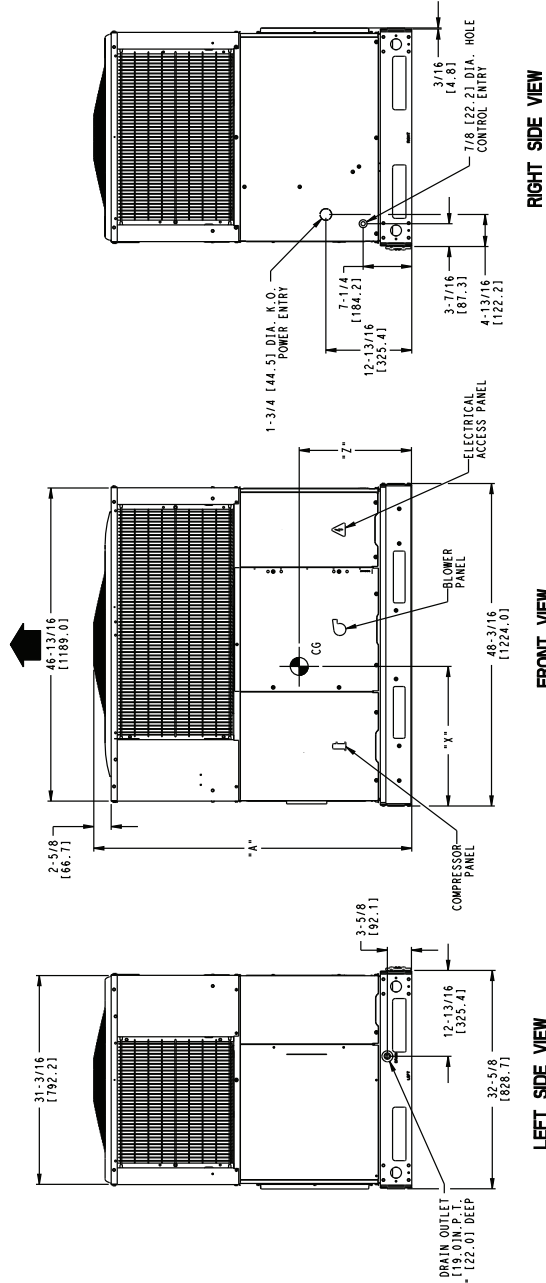

50VL500566 B

Fig. 2 – 24-36 Unit Dimensions

UNIT	ELECTRICAL CHARACTERISTICS			UNIT WT.		UNIT HEIGHT IN/MM			CENTER OF GRAVITY IN/MM				
	VOLTS	AMPS	KVA	LB	KG	"A"	"X"	"Y"	"Z"	"X"	"Y"	"Z"	
50VL-C42---(375/16)10	208/230-1-60	208/230-3-60	460-3-60	413	187.0	44-3/4	1137	20-1/4	514.4	17-1/2	444.5	17-5/8	447.7
50VL-C48---(375/16)10	208/230-1-60	208/230-3-60	460-3-60	438	199.0	52-3/4	1340	20-1/4	514.4	17-1/2	444.5	17-5/8	447.7
50VL-C60---(375/16)10	208/230-1-60	208/230-3-60	460-3-60	455	206.0	54-3/4	1391	20-1/4	514.4	17-1/2	444.5	18	457.2

UNIT	CORNER WEIGHTS LB/ING		
	"1"	"2"	"3"
42	208/230/460 42.0	28.1	82.6
48	208/230/460 45.7	29.8	87.6
60	208/230/460 48.3	31.0	91.0

REQUIRED CLEARANCES TO COMBUSTIBLE MATL.

	INCHES (MM)
TOP OF UNIT	2 (50.8)
DUCT SIDE OF UNIT	2 (50.8)
SIDE OPPOSITE DUCTS	14 (355.6)
BOTTOM OF UNIT	0 (0.0)
ELECTRICAL PANEL	36 (914.4)

NEC REQUIRED CLEARANCES

	INCHES (MM)
BETWEEN UNITS, POWER ENTRY SIDE	42 (1066.8)
UNIT AND UNGROUND SURFACES, POWER ENTRY SIDE	36 (914.0)
UNIT AND BLOCK OR CONCRETE WALLS AND OTHER GROUNDED SURFACES, POWER ENTRY SIDE	42 (1066.8)

REQUIRED CLEARANCE FOR OPERATION AND SERVICING

	INCHES (MM)
EVAP. COIL ACCESS SIDE	36 (914.0)
POWER ENTRY SIDE	42 (1066.8)
ACCESS FOR NEC REQUIREMENTS	48 (1219.2)
UNIT TOP	36 (914.0)
SIDE OPPOSITE DUCTS	36 (914.0)
DUCT PANEL	12 (304.8)

*MINIMUM DISTANCES IF UNIT IS PLACED LESS THAN 12 (304.8) FROM WALL SYSTEM, THEN SYSTEM PERFORMANCE MAYBE COMPROMISED. DIMENSIONS IN [] ARE IN MM

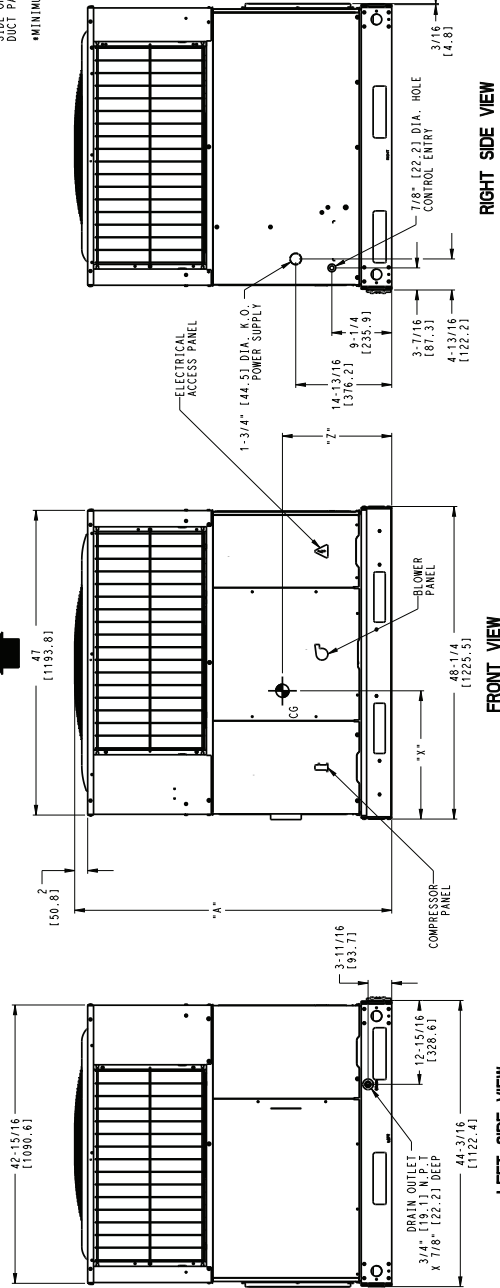
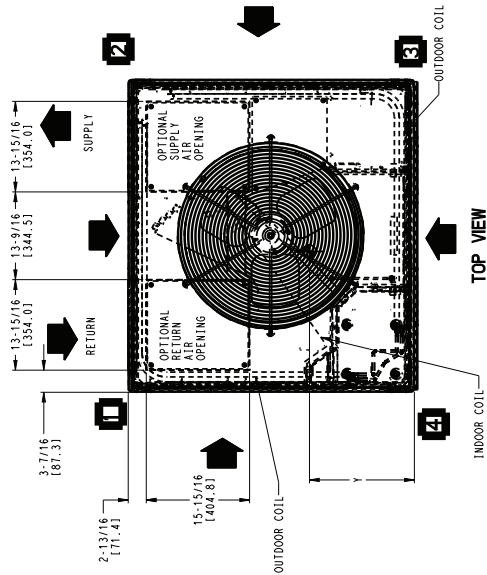

50VL500567

Fig. 3 – 42-60 Unit Dimensions

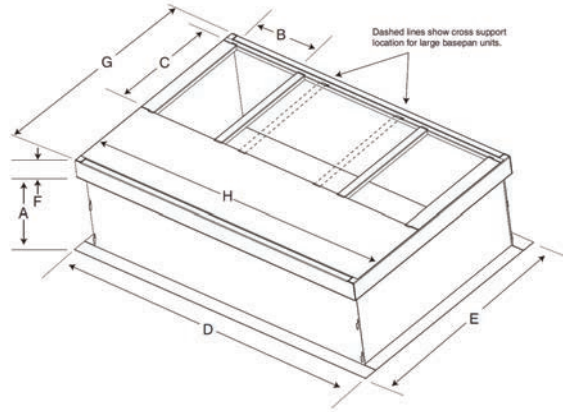
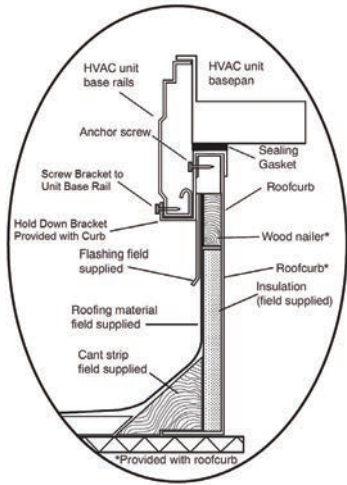

SMALL/Common CURB

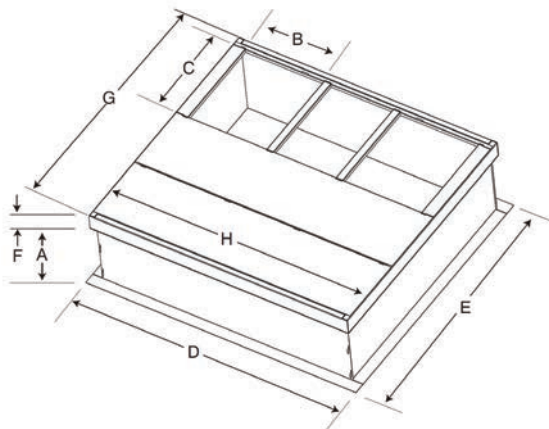

LARGE CURB

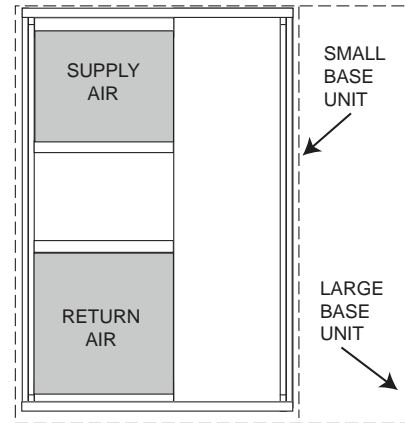

UNIT PLACEMENT ON COMMON CURB

SMALL OR LARGE BASE UNIT

A180216

UNIT SIZE	CATALOG NUMBER	A IN. (mm)	B (small/common base) IN. (mm)*	B (large base) IN. (mm)*	C IN. (mm)	D IN. (mm)	E IN. (mm)	F IN. (mm)	G IN. (mm)	H IN. (mm)
Small or Large	CPRFCURB011B00	14 (356)	10 (254)	14 (356)	16 (406)	47.8 (1214)	32.4 (822)	2.7 (69)	30.6 (778)	46.1 (1170)
Large	CPRFCURB013B00	14 (356)	14 (356)				43.9 (1116)			

*. Part Number CPRFCURB011B00 can be used on both small and large basepan units. The cross supports must be located based on whether the unit is a small basepan or a large basepan.

NOTES:

1. Roof curb must be set up for unit being installed.
2. Seal strip must be applied, as required, to unit being installed.
3. Roof curb is made of 16-gauge steel.
4. Attach ductwork to curb (flanges of duct rest on curb).
5. Insulated panels: 1-in. (25.4 mm) thick fiberglass 1 lb. density.

Fig. 4 – Roof Curb Dimensions

⚠ CAUTION - NOTICE TO RIGGERS ⚠ PRUDENCE - AVIS AUX MANIPULATEUR

ACCESS PANELS MUST BE IN PLACE WHEN RIGGING.
PANNEAUX D'ACCES DOIT ÊTRE EN PLACE POUR MANIPULATION.

Use top skid as spreader bar. / Utiliser la palette du haut comme barre de répartition

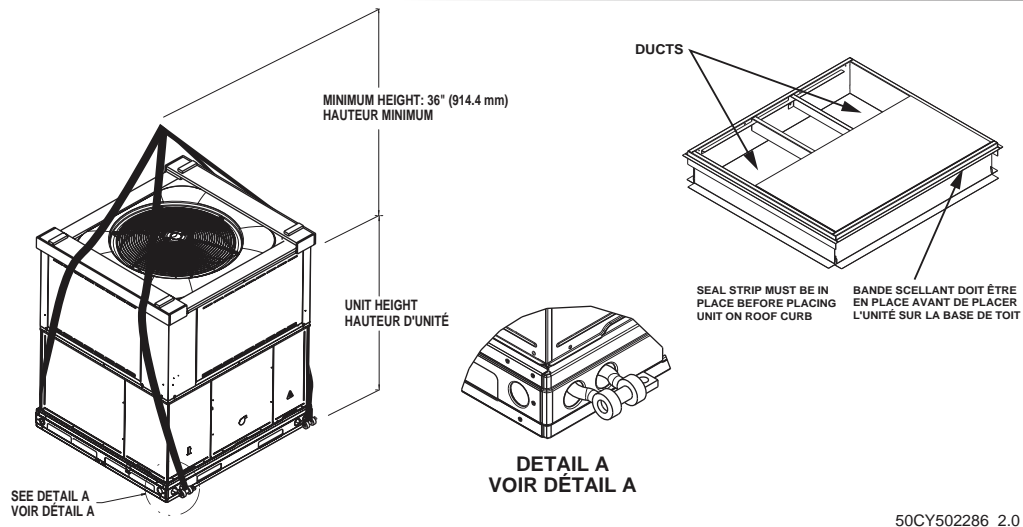

50CY502286 2.0

A09051

Unit	SMALL CABINET						Unit	LARGE CABINET					
	24		30		36			42		48		60	
Rigging Weight	lb	kg	lb	kg	lb	kg	lb	kg	lb	kg	lb	kg	
Rigging Weight	329	149	361	164	390	177	Rigging Weight	455	206	480	218	497	225

NOTE: See dimensional drawing for corner weights.

Fig. 5 – Unit Suggested Rigging

Step 3 – Provide Clearances

The required minimum service clearances are shown in Fig. 2 and Fig. 3. Adequate ventilation and outdoor air must be provided. The outdoor fan draws air through the outdoor coil and discharges it through the top fan grille. Be sure that the fan discharge does not recirculate to the outdoor coil. Do not locate the unit in either a corner or under an overhead obstruction. The minimum clearance under a partial overhang (such as a normal house overhang) is 48 in. (1219 mm) above the unit top. The maximum horizontal extension of a partial overhang must not exceed 48 in. (1219 mm)

IMPORTANT: Do not restrict outdoor airflow. An air restriction at either the outdoor-air inlet or the fan discharge may be detrimental to compressor life.

Do not place the unit where water, ice, or snow from an overhang or roof will damage or flood the unit. Do not install the unit on carpeting or other combustible materials. Slab-mounted units should be at least 2 in. (51 mm) above the highest expected water and runoff levels. Do not use unit if it has been under water.

Step 4 – Field-Fabricate Ductwork

Secure all ducts to roof curb and building structure on vertical discharge units. Do not connect ductwork to unit. For horizontal applications, unit is provided with flanges on the horizontal openings. All ductwork should be secured to the flanges. Insulate and weatherproof all external ductwork, joints, and roof openings with counter flashing and mastic in accordance with applicable codes.

Ducts passing through an unconditioned space must be insulated and covered with a vapor barrier. If a plenum return is used on a vertical unit, the return should be ducted through the roof deck to comply with

applicable fire codes. See unit rating plate for any required clearances around ductwork. Cabinet return-air static shall not exceed -.25 IN. W.C.

Step 5 – Rig and Place Unit

Rigging and handling of this equipment can be hazardous for many reasons due to the installation location (roofs, elevated structures, etc.).

Only trained, qualified crane operators and ground support staff should handle and install this equipment.

When working with this equipment, observe precautions in the literature, on tags, stickers, and labels attached to the equipment, and any other safety precautions that might apply.

Training for operators of the lifting equipment should include, but not be limited to, the following:

1. Application of the lifter to the load, and adjustment of the lifts to adapt to various sizes or kinds of loads.
2. Instruction in any special operation or precaution.
3. Condition of the load as it relates to operation of the lifting kit, such as balance, temperature, etc.

Follow all applicable safety codes. Wear safety shoes and work gloves.

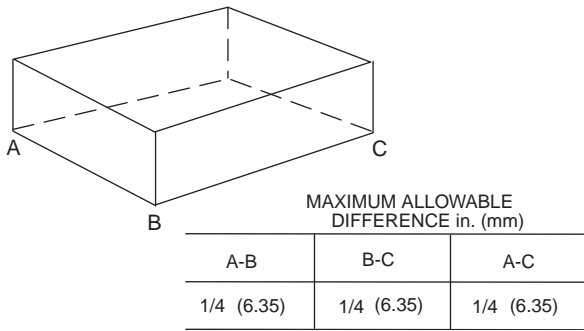

Fig. 6 – Unit Leveling Tolerances

A07925

Inspection

Prior to initial use, and at monthly intervals, all rigging shackles, clevis pins, and straps should be visually inspected for any damage, evidence of wear, structural deformation, or cracks. Particular attention should be paid to excessive wear at hoist hooking points and load support areas. Materials showing any kind of wear in these areas must not be used and should be discarded.

! WARNING

UNIT FALLING HAZARD
 Failure to follow this warning could result in personal injury or death. Never stand beneath rigged units or lift over people.

1. Leave top shipping skid on the unit for use as a spreader bar to prevent the rigging straps from damaging the unit. If the skid is not available, use a spreader bar of sufficient length to protect the unit from damage.

! WARNING

PROPERTY DAMAGE HAZARD
 Failure to follow this warning could result in personal injury. When straps are taut, the clevis should be a minimum of 36 in. (914 mm) above the unit top cover.

Rigging/Lifting of Unit (See Fig. 5)

! WARNING

UNIT FALLING HAZARD
 Failure to follow this warning could result in personal injury or death. Large base units must be secured to common curb before allowing full weight of unit to rest on curb. Install screws through curb into unit base rails while rigging crane is still supporting unit.

Lifting holes are provided in base rails as shown.

1. Attach shackles, clevis pins, and straps to the base rails of the unit. Be sure materials are rated to hold the weight of the unit (See Fig. 5).
2. Attach a clevis of sufficient strength in the middle of the straps. Adjust the clevis location to ensure unit is lifted level with the ground.

After the unit is placed on the roof curb or mounting pad, remove the top skid.

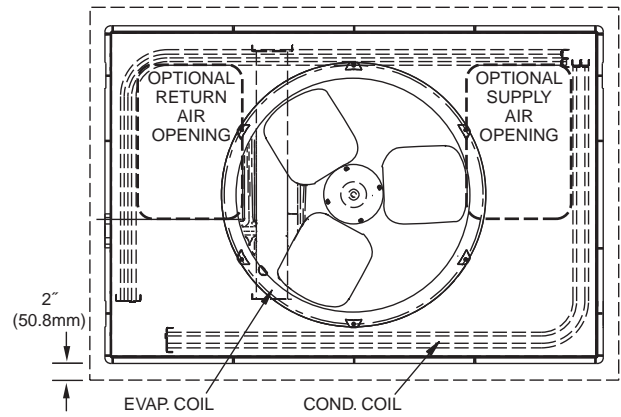

Fig. 7 – Slab Mounting Detail

A07926

Step 6 – Connect Condensate Drain

NOTE: When installing condensate drain connection be sure to comply with local codes and restrictions.

Unit disposes of condensate water through a 3/4 in. NPT fitting which exits through the base on the evaporator coil access side. See Fig. 2 and Fig. 3 for location.

Condensate water can be drained directly onto the roof in rooftop installations (where permitted) or onto a gravel apron in ground level installations. Install a field-supplied 2-in. (51 mm) condensate trap at end of condensate connection to ensure proper drainage. Make sure that the outlet of the trap is at least 1 in. (25 mm) lower than the drain pan condensate connection to prevent the pan from overflowing (See Fig. 8). When using a gravel apron, make sure it slopes away from the unit.

Connect a drain tube using a minimum of 3/4 -in. PVC or 3/4 -in. copper pipe (all field-supplied) at the outlet end of the 2-in. (51 mm) trap. Do not undersize the tube. Pitch the drain tube downward at a slope of at least 1-in. (25 mm) for every 10 ft (3.1 m) of horizontal run. Be sure to check the drain tube for leaks. Prime trap at the beginning of the cooling season start-up.

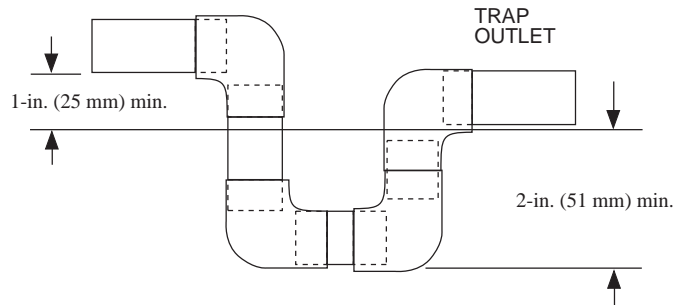

Fig. 8 – Condensate Trap

A09052

Step 7 – Install Duct Connections

The design and installation of the duct system must be in accordance with the standards of the NFPA for installation of non-residence type air conditioning and ventilating systems, NFPA 90A or residence type, NFPA 90B and/or local codes and ordinances.

Select and size ductwork, supply-air registers, and return air grilles according to ASHRAE (American Society of Heating, Refrigeration, and Air Conditioning Engineers) recommendations. The unit has duct flanges on the supply- and return-air openings on the side of the unit.

When designing and installing ductwork, consider the following:

1. All units should have field-supplied filters or accessory filter rack installed in the return-air side of the unit. Recommended sizes for filters are shown in Table 1.
2. Avoid abrupt duct size increases and reductions. Abrupt change in duct size adversely affects air performance.

IMPORTANT: Use flexible connectors between ductwork and unit to prevent transmission of vibration. Use suitable gaskets to ensure weather-tight and airtight seal. When electric heat is installed, use fireproof canvas (or similar heat resistant material) connector between ductwork and unit discharge connection. If flexible duct is used, insert a sheet metal sleeve inside duct. Heat resistant duct connector (or sheet metal sleeve) must extend 24-in. (610 mm) from electric heater element.

3. Size ductwork for cooling air quantity (cfm). The minimum air quantity for proper electric heater operation is listed in [Table 2](#). Heater limit switches may trip at air quantities below those recommended.
4. Seal, insulate, and weatherproof all external ductwork. Seal, insulate and cover with a vapor barrier all ductwork passing through conditioned spaces. Follow latest Sheet Metal and Air Conditioning Contractors National Association (SMACNA) and Air Conditioning Contractors Association (ACCA) minimum installation standards for residential heating and air conditioning systems.
5. Secure all ducts to building structure. Flash, weatherproof, and vibration-isolate duct openings in wall or roof according to good construction practices.

Configuring Units for Downflow (Vertical) Discharge

! WARNING

ELECTRICAL SHOCK HAZARD

Failure to follow this warning could result in personal injury or death. Before performing service or maintenance operations on the system, turn off main power to unit and install lockout tag. There may be more than one disconnect switch.

1. Open all electrical disconnects and install lockout tag before starting any service work.
2. Remove horizontal (metal) ductcovers to access vertical (downflow) discharge duct knockouts in unit basepan. (See [Fig. 9](#).)

To remove downflow return and supply knockout covers, break front and right side connecting tabs with a screwdriver and hammer. Push cover down to break rear and left side tabs.

NOTE: These panels are held in place with tabs similar to an electrical knockout. Reinstall horizontal duct covers ([Fig. 9](#)) shipped on unit from factory. Insure openings are air and watertight.

NOTE: The design and installation of the duct system must be in accordance with the standards of the NFPA for installation of nonresidence-type air conditioning and ventilating systems, NFPA 90A or residence-type, NFPA 90B; and/or local codes and ordinances.

Adhere to the following criteria when selecting, sizing, and installing the duct system:

1. Units are shipped for side shot installation.
2. Select and size ductwork, supply-air registers, and return-air grilles according to American Society of Heating, Refrigeration and Air Conditioning Engineers (ASHRAE) recommendations.
3. Use flexible transition between rigid ductwork and unit to prevent transmission of vibration. The transition may be screwed or bolted to duct flanges. Use suitable gaskets to ensure weather-tight and airtight seal.
4. All units must have field-supplied filters or accessory filter rack installed in the return-air side of the unit. Recommended sizes for filters are shown in [Table 1](#).
5. Size all ductwork for maximum required airflow (either heating or cooling) for unit being installed. Avoid abrupt duct size increases or decreases or performance may be affected.

6. Adequately insulate and weatherproof all ductwork located outdoors. Insulate ducts passing through unconditioned space, and use vapor barrier in accordance with latest issue of Sheet Metal and Air Conditioning Contractors National Association (SMACNA) and Air Conditioning Contractors of America (ACCA) minimum installation standards for heating and air conditioning systems. Secure all ducts to building structure.
7. Flash, weatherproof, and vibration-isolate all openings in building structure in accordance with local codes and good building practices.

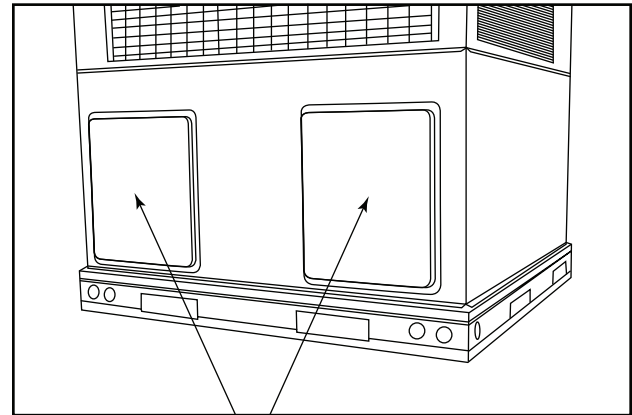

Horizontal Duct Covers

A09061

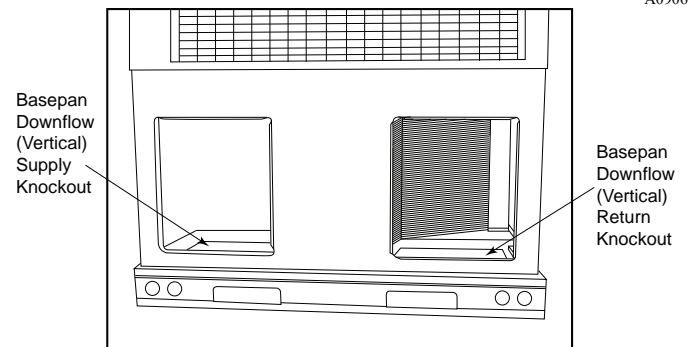

Basepan
Downflow
(Vertical)
Supply
Knockout

Basepan
Downflow
(Vertical)
Return
Knockout

A09088

Fig. 9 – Supply and Return Duct Opening
Step 8 – Install Electrical Connections

! WARNING

ELECTRICAL SHOCK HAZARD

Failure to follow this warning could result in personal injury or death. The unit cabinet must have an uninterrupted, unbroken electrical ground to minimize the possibility of personal injury if an electrical fault should occur. This ground may consist of an electrical wire connected to the unit ground screw in the control compartment, or conduit approved for electrical ground when installed in accordance with NFPA 70 (NEC) (latest edition) (in Canada, Canadian Electrical Code CSA C22.1) and local electrical codes.

! CAUTION

UNIT COMPONENT DAMAGE HAZARD

Failure to follow this caution may result in damage to the unit being installed.

1. Make all electrical connections in accordance with NFPA 70 (NEC) (latest edition) and local electrical codes governing such wiring. In Canada, all electrical connections must be in accordance with CSA standard C22.1 Canadian Electrical Code Part 1 and applicable local codes. Refer to unit wiring diagram.
2. Use only copper conductor for connections between field-supplied electrical disconnect switch and unit. **DO NOT USE ALUMINUM WIRE.**
3. Be sure that high-voltage power to unit is within operating voltage range indicated on unit rating plate. On 3-phase units, ensure phases are balanced within 2 percent. Consult local power company for correction of improper voltage and/or phase imbalance.
4. Do not damage internal components when drilling through any panel to mount electrical hardware, conduit, etc.

High-Voltage Connections

The unit must have a separate electrical service with a field-supplied, waterproof disconnect switch mounted at, or within sight from the unit. Refer to the unit rating plate, NEC and local codes for maximum fuse/circuit breaker size and minimum circuit amps (ampacity) for wire sizing.

The field-supplied disconnect may be mounted on the unit over the high-voltage inlet hole when the standard power and low-voltage entry points are used. See Fig. 2 and Fig. 3 for acceptable location.

See unit wiring label (Fig. 12 - Fig. 19) and Fig. 10 for reference when making high voltage connections. Proceed as follows to complete the high-voltage connections to the unit.

Single phase units:

1. Run the high-voltage (L1, L2) and ground lead into the control box.
2. Connect ground lead to chassis ground connection.
3. Locate the black and yellow wires connected to the line side of the contactor.
4. Connect field L1 to black wire on connection 11 of the compressor contactor.

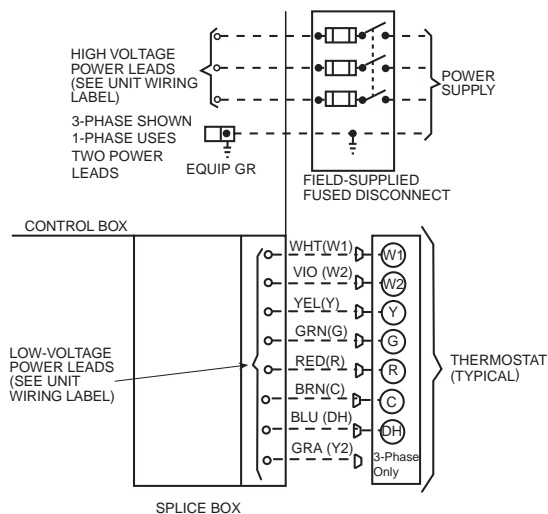

Fig. 10 – High- and Control-Voltage Connections

A09066

5. Connect field wire L2 to yellow wire on connection 23 of the compressor contactor.

Three-phase units:

1. Run the high-voltage (L1, L2, L3) and ground lead into the control box.
2. Connect ground lead to chassis ground connection.
3. Locate the black and yellow wires connected to the line side of the contactor.
4. Connect field L1 to black wire on connection 11 of the compressor contactor.
5. Connect field wire L3 to yellow wire on connection 13 of the compressor contactor.
6. Connect field wire L2 to blue wire from compressor.

Special Procedures for 208-V Operation

! WARNING

ELECTRICAL SHOCK HAZARD

Failure to follow this warning could result in personal injury or death.

Before installing or servicing system, always turn off main power to system and install lockout tag. With disconnect switch open, move black wire from transformer (3/16 in.)(4.8 mm) terminal marked 230 to terminal marked 208. This retaps transformer to primary voltage of 208 vac.

Control Voltage Connections

NOTE: Do not use any type of power-stealing thermostat. Unit control problems may result.

Use no. 18 American Wire Gage (AWG) color-coded, insulated (35°C minimum) wires to make the control voltage connections between the thermostat and the unit. If the thermostat is located more than 100 ft (30.5 m) from the unit (as measured along the control voltage wires), use no. 16 AWG color-coded, insulated (35° C minimum) wires.

Standard Connection

Locate the seven (eight for 3-phase) low voltage thermostat leads in 24 volt splice box. A gray wire is standard on 3-phase units for connection to an economizer. See Fig. 10 for connection diagram. Run the low-voltage leads from the thermostat, through the control wiring inlet hole grommet (Fig. 2 and Fig. 3), and into the low-voltage splice box. Provide a drip loop before running wires through panel. Secure and strain relief all wires so that they do not interfere with operation of unit.

If an accessory electric heater is installed, low voltage leads from heater must be connected to factory supplied control leads from Indoor Fan Board P4 connector.

NOTE: If the unit 24V wires do not have a matching receptacle, cut the 24V wires from the electric heater plug, strip the ends, and wire nut together to match the schematic connections. If the electric heater 24V wires do not have a matching plug, cut the 24V wires from the unit receptacle, strip the ends, and wire nut together to match the schematic connections.

Factory wires are provided for electric heat staging W1 and W2 (W2 and W3 on IFB). If room thermostat has only one stage of supplemental heat, connect white and violet wires shown in Fig. 10 to second stage heat field wire.

Some electric heaters have four control wires (plus common wire). Consult unit wiring diagram and electric heater wiring diagram for additional details.

Transformer Protection

The transformer is of the energy-limiting type, however a direct short will likely blow a secondary fuse. If an overload or short is present, correct overload condition and check for blower fuse on Indoor Fan Board. Replace fuse as required with correct size and rating.

Table 1 – Physical Data-Unit

UNIT SIZE	24	30	36	42	48	60
NOMINAL CAPACITY (ton)	2	2-1/2	3	3-1/2	4	5
SHIPPING WEIGHT lb.	329	361	390	455	480	497
SHIPPING WEIGHT (kg)	149	164	177	206	218	225
COMPRESSORS	Rotary		Scroll			
Quantity	1					
REFRIGERANT (R-410A)						
Quantity lb	5.3	6.0	8.2	6.2	9.2	9.8
Quantity (kg)	2.4	2.7	3.7	2.8	4.2	4.5
REFRIGERANT METERING DEVICE	Orifice		TXV	Orifice		
ORIFICE ID in./mm	.059 / 1.5	.063 / 1.60	N/A	.073 / 1.85	.080 / 2.03	.084 / 2.14
OUTDOOR COIL						
Rows...Fins/in.	1...21	1...21	1...21	1...21	1...21	1...21
Face Area (sq ft)	11.9	13.6	18.8	13.6	21.4	23.3
OUTDOOR FAN						
Nominal Cfm	2500	2700	3200	3600	3600	4200
Diameter in.	24	24	24	26	26	26
Diameter (mm)	609.6	609.6	609.6	660.4	660.4	660.4
Motor Hp (Rpm)	1/12 (810)	1/10 (810)	1/5 (810)	1/5 (810)	1/5 (810)	1/5 (810)
INDOOR COIL						
Rows...Fins/in.	3...17	3...17	3...17	3...17	3...17	3...17
Face Area (sq ft)	3.7	3.7	3.7	4.7	4.7	5.6
INDOOR BLOWER						
Nominal Cooling Airflow (Cfm)	800	1000	1150	1350	1550	1750
Size in.	10x10	10x10	11x10	11x10	11x10	11x10
Size (mm.)	254x254	254x254	279.4x254	279.4x254	279.4x254	279.4x254
Motor HP (RPM)	1/2 (1050)	1/2 (1050)	3/4 (1000)	1/2 (1075)	1.0 (1075)	1.0 (1040)
HIGH-PRESSURE SWITCH (psig) Cut-out Reset (Auto)	650 +/- 15 420 +/- 25					
LOSS-OF-CHARGE / LOW-PRESSURE SWITCH (psig) cut-out Reset (auto)	50 +/-7 95 +/- 7		N/A			
RETURN-AIR FILTERS* † Throwaway Size in. Throwaway Size (mm)	2 each 20x12x1 508x305x25			1 each 24x14x1 610x356x25 24x15x1 610x406x25		1 each 24x16x1 610x406x25 24x18x1 610x457x25

*. Required filter sizes shown are based on the larger of the AHRI (Air Conditioning Heating and Refrigeration Institute) rated cooling airflow or the heating airflow velocity of 300 to 350 ft/minute for throwaway type or 450 ft/minute for high-capacity type. Air filter pressure drop for non-standard filters must not exceed 0.08 in. W.C.

†. If using accessory filter rack refer to the filter rack installation instructions for correct filter sizes and quantity.

Table 2 – Minimum Airflow for Safe Electric Heater Operation (CFM)

SIZE	24	30	36	42	48	60
Cfm	800	1000	1200	1400	1600	1750

Pre-Start-up

WARNING

ENVIRONMENTAL, FIRE, EXPLOSION, ELECTRICAL SHOCK HAZARD

Failure to follow this warning could result in personal injury or death and/or property damage.

1. Follow recognized safety practices and wear protective goggles when checking or servicing refrigerant system.
2. Relieve and recover all refrigerant from system before touching or disturbing compressor plug if refrigerant leak is suspected around compressor terminals.
3. Never attempt to repair soldered connection while refrigerant system is under pressure.
4. Do not use torch to remove any component. System contains oil and refrigerant under pressure.
5. To remove a component, wear protective goggles and proceed as follows:
 - a. Shut off electrical power to unit and install lockout tag.
 - b. Relieve and reclaim all refrigerant from system using both high- and low-pressure ports.
 - c. Cut component connecting tubing with tubing cutter and remove component from unit.
 - d. Carefully unsweat remaining tubing stubs when necessary. Oil can ignite when exposed to torch flame.

Proceed as follows to inspect and prepare the unit for initial start-up:

1. Remove all access panels (see Fig. 22).
2. Read and follow instructions on all DANGER, WARNING, CAUTION, and INFORMATION labels attached to, or shipped with unit.
3. Make the following inspections:
 - a. Inspect for shipping and handling damages, such as broken lines, loose parts, disconnected wires, etc.
 - b. Inspect all field- and factory-wiring connections. Be sure that connections are completed and tight.
 - c. Ensure wires do not touch refrigerant tubing or sharp sheet metal edges.
 - d. Inspect coil fins. If damaged during shipping and handling, carefully straighten fins with a fin comb.
4. Verify the following conditions:
 - a. Make sure that condensate drain pan and trap are filled with water to ensure proper drainage.
 - b. Make sure that all tools and miscellaneous loose parts have been removed.

Start-up

Step 1 – Check for Refrigerant Leaks

WARNING



EXPLOSION HAZARD

Failure to follow this warning could result in death, serious personal injury, and/or property damage.

Never use air or gases containing oxygen for leak testing or operating refrigerant compressors. Pressurized mixtures of air or gases containing oxygen can lead to an explosion.

Proceed as follows to locate and repair a refrigerant leak and to charge the unit:

1. Locate leak and make sure that refrigerant system pressure has been relieved and reclaimed from both high- and low-pressure ports.
2. Repair leak following accepted practices.

NOTE: Install a filter drier whenever the system has been opened for repair.

3. Add a small charge of Puron (R-410A) refrigerant vapor to system and leak-test unit.
4. Recover refrigerant from system and evacuate to 500 microns if no additional leaks are found.
5. Charge unit with Puron (R-410A) refrigerant, using an accurate scale. Refer to unit rating plate for required charge.

Step 2 – Start-Up Cooling Section And Make Adjustments

Complete the required procedures given in the Pre-Start-Up section before starting the unit. Do not jumper any safety devices when operating the unit. Do not operate the unit when the outdoor temperature is below 40°F (4°C) (unless accessory low-ambient kit is installed). Do not rapid cycle the compressor. Allow 5 minutes between “on” cycles to prevent compressor damage.

Checking Cooling Control Operation

Start and check the unit for proper cooling control operation as follows:

1. Place room thermostat SYSTEM switch in OFF position. Observe that blower motor starts when FAN switch is placed in ON position and shuts down when FAN switch is placed in AUTO position.
2. Place SYSTEM switch in COOL position and FAN switch in AUTO position. Set cooling control below room temperature. Observe that compressor, condenser fan, and evaporator blower motors start. Observe that compressor and outdoor fan shut down when control setting is satisfied and that indoor blower shuts down after 90 second fan time delay expires.

IMPORTANT: Three-phase, scroll compressors are direction oriented. Unit must be checked to ensure proper compressor 3-phase power lead orientation. If not corrected within 5 minutes, the internal protector will shut off the compressor. The 3-phase power leads to the unit must be reversed to correct rotation. When turning backwards, the difference between compressor suction and discharge pressures may be minimal.

Checking and Adjusting Refrigerant Charge

The refrigerant system is fully charged with Puron (R-410A) refrigerant and is tested and factory sealed.

WARNING



EXPLOSION HAZARD

Failure to follow this warning could result in death, serious personal injury, and/or property damage.

Never use air or gases containing oxygen for leak testing or operating refrigerant compressors. Pressurized mixtures of air or gases containing oxygen can lead to an explosion.

NOTE: Adjustment of the refrigerant charge is not required unless the unit is suspected of not having the proper Puron (R-410A) charge.

NOTE: Some units have fixed orifice refrigerant metering devices. There is a different charging procedure for both expansion devices. Refer to the correct procedure for your unit.

The charging label and the tables shown refer to system temperatures and pressures in cooling mode only. A refrigerant charging label is

attached to the inside of the compressor access panel. (See Fig. 20 Subcool chart for units with TXV and superheat chart for units with fixed orifice.) The chart includes the required liquid line temperature at given discharge line pressures and outdoor ambient temperatures.

A superheat chart is attached to the inside of the compressor access panel for the unit with fixed metering device. Refer to the charging procedure on the label.

An accurate thermocouple- or thermistor-type thermometer, and a gauge manifold are required when using the subcooling charging method for evaluating the unit charge. Do not use mercury or small dial-type thermometers because they are not adequate for this type of measurement.

NOTE: Allow system to operate for a minimum of 15 minutes before checking or adjusting refrigerant charge.

IMPORTANT: When evaluating the refrigerant charge, an indicated adjustment to the specified factory charge must always be very minimal. If a substantial adjustment is indicated, an abnormal condition exists somewhere in the cooling system, such as insufficient airflow across either coil or both coils.

Proceed as follows:

1. Remove caps from low- and high-pressure service fittings.
2. Using hoses with valve core depressors, attach low- and high-pressure gauge hoses to low- and high-pressure service fittings, respectively.
3. Start unit and let run until system pressures stabilize.
4. Measure and record the following:
 - a. Outdoor ambient-air temperature (°F [°C] db).
 - b. Liquid line temperature (°F [°C]) at TXV.
 - c. Discharge (high-side) pressure (psig).
 - d. Suction (low-side) pressure (psig) (for reference only).
5. Using Cooling Charging Charts compare outdoor-air temperature (°F [°C] db) with the discharge line pressure (psig) to determine desired system operating liquid line temperature (See Fig. 20).
6. Compare actual liquid line temperature with desired liquid line temperature. Using a tolerance of $\pm 2^{\circ}\text{F}$ ($\pm 1.1^{\circ}\text{C}$), add refrigerant if actual temperature is more than 2°F (1.1°C) higher than proper liquid line temperature, or remove refrigerant if actual temperature is more than 2°F (1.1°C) lower than required liquid line temperature.

NOTE: If the problem causing the inaccurate readings is a refrigerant leak, refer to Check for Refrigerant Leaks section.

Indoor Airflow and Airflow Adjustments

! CAUTION

UNIT OPERATION HAZARD

Failure to follow this caution may result in unit damage.

For cooling operation, the recommended airflow is 350 to 450 cfm for each 12,000 Btuh of rated cooling capacity. For heating operation, the airflow must produce a temperature rise that falls within the range stamped on the unit rating plate.

NOTE: Be sure that all supply-and return-air grilles are open, free from obstructions, and adjusted properly.

! WARNING

ELECTRICAL SHOCK HAZARD

Failure to follow this warning could result in personal injury or death.

Disconnect electrical power to the unit and install lockout tag before changing blower speed.

This unit is factory-set up for use with a single cooling fan speed. In addition, this unit has the field-selectable capability to run two different cooling fan speeds: The rated cooling fan speed (350~400 CFM/Ton) and an enhanced dehumidification fan speed (As low as 320 CFM/Ton) for use with either a dehumidistat or a thermostat that supports dehumidification.

The cooling speed is marked “LOW” on the interface fan board (IFB) (See Fig. 11). The factory-shipped settings are noted in Table 4. There are 4 additional speed tap wires available for use in either electric heating or cooling (For color coding on the indoor fan motor leads, see Table 3). The additional 4 speed tap wires are shipped loose with vinyl caps and are located in the control box, near the interface fan board (IFB) (See Fig. 11).

Single Cooling Fan Speed Set-up (Dehumidification feature not used)

To change cooling speed:

1. Remove the vinyl cap off of the desired speed tap wire (Refer to Table 3 for color coding). Add the wet coil pressure drop in Table 7 to the system static to determine the correct cooling airflow speed in Table that will deliver the nominal cooling airflow as listed in Table for each size.
2. Remove the current speed tap wire from the “LOW” terminal on the interface fan board (IFB) (See Fig. 11) and place vinyl cap over the connector on the wire.
3. Connect the desired speed tap wire to the “LOW” terminal on the interface fan board (IFB).

NOTE: If accessory electric heat is installed, and the electric heat fan speed is chosen to be the same as the normal cooling fan speed, the dry airflow must meet or exceed the minimum airflow speed specified in Table 2 for the specific size unit.

Two Cooling Fan Speeds Set-up (Dehumidification feature used)

IMPORTANT: Dehumidification control must open control circuit on humidity rise above set point.

Use of the dehumidification cooling fan speed requires use of either a 24 VAC dehumidistat or a thermostat which includes control of a 24 VAC dehumidistat connection. In either case, the dehumidification control must open the control circuit on humidity rise above the dehumidification set point.

1. Using Fig. 11, move the two pin DEHUM jumper from the “STD” position to the “DEHUM” position.
2. Remove fan speed tap wire from the “LOW” terminal on the interface fan board (IFB) (See Fig. 11).
3. Determine correct normal cooling fan speed for unit and application. Add the wet coil pressure drop in Table 7 to the system static to determine the correct cooling airflow speed in Table 5 that will deliver the nominal cooling airflow as listed in Table 1 for each size.

NOTE: If accessory electric heat is installed, the dry airflow must meet or exceed the minimum airflow speed specified in Table 2 for the specific size unit. The electric heat fan speed will be the same as the normal cooling fan speed.

4. Remove the vinyl cap off of the desired speed tap wire (Refer to Table 3 for color coding) for the normal cooling fan speed and place desired speed tap wire on “HIGH” on the interface board.
5. Refer to airflow tables (Table 4-Table 6) to determine allowable speeds for the dehumidification cooling fan speed. In Table 4, speeds that are not allowed for dehumidification cooling are shaded.
6. Remove the vinyl cap off of the desired speed tap wire (Refer to Table 3 for color coding) for the dehumidification cooling fan speed and place desired speed tap wire on the “LOW” connection on the

interface board (IFB). Verify that static pressure is in the acceptable range for the speed tap to be used for dehumidification cooling.

- Use any spare vinyl plugs to cap any unused speed tap wires.

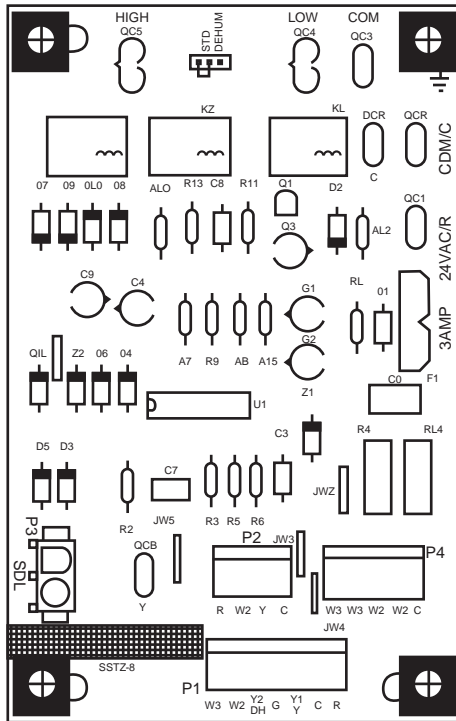

Fig. 11 – Interface Fan Board (IFB)

A09059

Single Speed Cooling with Higher Electric Heat Speed

This unit can also be configured to operate with single speed cooling and a higher speed for an accessory electric heater.

- Using Fig. 11, move the two pin DEHUM jumper from the “STD” position to the “DEHUM” position.
- See Table 2 for minimum airflow for electric heat operation. Add electric heater and filter pressure drop to duct system static pressure to determine total external static pressure.
- Select speed tap from Table 5 that will achieve required airflow from Table 2.
- Remove the vinyl cap off of the desired speed tap wire (Refer to Table 3 for color coding).
- Connect the desired speed tap wire to the “HIGH” terminal on the interface fan board (IFB).

! CAUTION

UNIT OPERATION HAZARD

Failure to follow this caution may result in unit component damage or improper operation.

To use this mode, a speed connection must be made on the “HIGH” terminal that meets or exceeds the minimum airflow found in Table 2.

Table 3 – Color Coding for Indoor Fan Motor Leads

Black = High Speed
Orange = Med-High Speed
Red = Med Speed
Pink = Med-Low Speed
Blue = Low Speed

! WARNING

ELECTRICAL SHOCK HAZARD

Failure to follow this warning could result in personal injury or death. Disconnect electrical power to the unit and install lockout tag before changing blower speed.

Continuous Fan Operation

When the DEHUM feature is not used, the continuous fan speed will be the same as cooling fan speed. When the DEHUM feature is used, the continuous fan will operate on IFB “LOW” speed when the DH control lead is not energized, or IFB “HIGH” speed when the DH lead is energized (see Fig. 11).

Cooling Sequence of Operation

With the room thermostat SYSTEM switch in the COOL position and the FAN switch in the AUTO position, the cooling sequence of operation is as follows:

When the room temperature rises to a point that is slightly above the cooling control setting of the thermostat, the thermostat completes the circuit between thermostat terminal R to terminals Y and G. These completed circuits through the thermostat connect contactor coil (C) (through unit wire Y) and time delay relay (TDR) (through unit wire G) across the 24-V secondary of transformer (TRAN).

The normally open contacts of energized contactor (C) close and complete the circuit through compressor motor (COMP) to condenser (outdoor) fan motor (OFM). Both motors start instantly.

A set of normally open contacts on the interface fan board (IFB) are closed which energizes a circuit to the indoor fan motor (IFB).

NOTE: Once the compressor has started and then has stopped, it should not be started again until 5 minutes have elapsed.

The cooling cycle remains on until the room temperature drops to a point that is slightly below the cooling control setting of the room thermostat. At this point, the thermostat breaks the circuit between thermostat terminal R to terminals Y and G. These open circuits deenergize contactor coil C and IFB. The condenser and compressor motors stop. After a 90-second delay, the blower motor stops. The unit is in a standby condition, waiting for the next call for cooling from the room thermostat.

Table 4 – Dry Coil Air Delivery* - Horizontal and Downflow Discharge Sizes 24-60 208/230VAC 1 Phase Models

Unit Size	Motor Speed	Wire Color		External Static Pressure (IN. W.C.)									
				0.1	0.2	0.3	0.4	0.5	0.6	0.7	0.8	0.9	1
24	Low	Blue	CFM	669	580	525	423	303	---	---	---	---	---
			BHP	0.09	0.10	0.11	0.11	0.12	---	---	---	---	---
	Med-Low1	Pink	CFM	829	752	680	602	549	455	313	---	---	---
			BHP	0.14	0.15	0.15	0.16	0.17	0.17	0.18	---	---	---
	Medium	Red	CFM	1014	929	884	818	746	683	600	537	405	305
			BHP	0.24	0.24	0.24	0.25	0.26	0.26	0.27	0.27	0.27	0.29
	Med-High	Orange	CFM	1041	972	916	850	782	713	631	581	465	340
			BHP	0.25	0.26	0.26	0.26	0.26	0.27	0.28	0.29	0.30	0.31
High	Black	CFM	1187	1124	1061	996	930	896	840	776	698	610	
		BHP	0.36	0.36	0.37	0.37	0.38	0.38	0.39	0.39	0.39	0.40	
30	Low	Blue	CFM	669	580	525	423	303	---	---	---	---	---
			BHP	0.09	0.10	0.11	0.11	0.12	---	---	---	---	---
	Med-Low	Pink	CFM	829	752	680	602	549	455	313	---	---	---
			BHP	0.14	0.15	0.15	0.16	0.17	0.17	0.18	---	---	---
	Medium1	Red	CFM	1014	929	884	818	746	683	600	537	405	305
			BHP	0.24	0.24	0.24	0.25	0.26	0.26	0.27	0.27	0.27	0.29
	Med-High	Orange	CFM	1041	972	916	850	782	713	631	581	465	340
			BHP	0.25	0.26	0.26	0.26	0.26	0.27	0.28	0.29	0.30	0.31
High	Black	CFM	1187	1124	1061	996	930	896	840	776	698	610	
		BHP	0.36	0.36	0.37	0.37	0.38	0.38	0.39	0.39	0.39	0.40	
36	Low	Blue	CFM	1056	982	911	882	812	740	667	564	486	361
			BHP	0.24	0.24	0.24	0.26	0.26	0.27	0.28	0.29	0.30	0.30
	Med-Low	Pink	CFM	1174	1107	1045	985	914	890	825	760	673	572
			BHP	0.32	0.32	0.33	0.33	0.34	0.35	0.36	0.37	0.37	0.37
	Medium1	Red	CFM	1246	1195	1148	1081	1019	953	884	859	795	690
			BHP	0.38	0.39	0.39	0.40	0.40	0.41	0.42	0.42	0.42	0.43
	Med-High	Orange	CFM	1361	1299	1229	1210	1152	1092	1025	958	889	822
			BHP	0.48	0.49	0.49	0.50	0.50	0.51	0.51	0.51	0.51	0.52
High	Black	CFM	1596	1542	1482	1424	1362	1304	1238	1173	1201	1143	
		BHP	0.74	0.74	0.74	0.75	0.75	0.75	0.76	0.76	0.76	0.77	
42	Low	Blue	CFM	1001	902	833	777	717	650	575	527	466	419
			BHP	0.13	0.13	0.14	0.14	0.15	0.16	0.17	0.18	0.19	0.20
	Med-Low	Pink	CFM	1016	950	902	842	783	721	655	590	541	480
			BHP	0.13	0.14	0.15	0.16	0.17	0.18	0.19	0.20	0.21	0.22
	Medium1	Red	CFM	1403	1358	1316	1265	1217	1167	1116	1067	1012	956
			BHP	0.29	0.30	0.31	0.33	0.34	0.35	0.36	0.37	0.38	0.39
	Med-High	Orange	CFM	1461	1411	1367	1327	1275	1220	1174	1127	1074	1022
			BHP	0.32	0.33	0.35	0.36	0.37	0.38	0.39	0.40	0.41	0.42
High	Black	CFM	1575	1528	1488	1447	1406	1360	1314	1264	1213	1159	
		BHP	0.40	0.42	0.43	0.44	0.45	0.46	0.47	0.48	0.49	0.50	
48	Low	Blue	CFM	1378	1344	1295	1260	1216	1179	1135	1087	1035	995
			BHP	0.26	0.27	0.29	0.31	0.31	0.33	0.34	0.36	0.36	0.38
	Med-Low1	Pink	CFM	1696	1671	1631	1607	1574	1539	1507	1463	1432	1393
			BHP	0.45	0.47	0.49	0.50	0.52	0.52	0.54	0.55	0.57	0.58
	Medium	Red	CFM	1994	1968	1943	1910	1882	1835	1774	1702	1614	1512
			BHP	0.72	0.73	0.75	0.76	0.78	0.78	0.76	0.73	0.70	0.66
	Med-High	Orange	CFM	2054	2013	1986	1964	1919	1854	1779	1695	1605	1498
			BHP	0.77	0.79	0.80	0.82	0.81	0.80	0.76	0.74	0.69	0.65
	High	Black	CFM	2267	2201	2133	2071	1997	1923	1835	1739	1654	1551
			BHP	1.03	1.00	0.97	0.93	0.89	0.86	0.82	0.78	0.74	0.69

Manufacturer reserves the right to change, at any time, specifications and designs without notice and without obligations.

Table 4 – Dry Coil Air Delivery* - Horizontal and Downflow Discharge Sizes 24-60 208/230VAC 1 Phase Models

60	Low	Blue	CFM	1330	1277	1232	1191	1147	1103	1060	1004	963	919
			BHP	0.26	0.27	0.29	0.30	0.31	0.32	0.33	0.34	0.36	0.37
	Med-Low	Pink	CFM	1475	1436	1399	1351	1317	1270	1236	1188	1152	1105
			BHP	0.35	0.36	0.37	0.38	0.40	0.41	0.42	0.43	0.45	0.45
	Medium1	Red	CFM	1736	1710	1668	1630	1600	1557	1522	1479	1450	1406
			BHP	0.53	0.54	0.55	0.58	0.59	0.60	0.62	0.63	0.64	0.65
	Med-High	Orange	CFM	1935	1909	1867	1836	1808	1766	1696	1619	1535	1454
			BHP	0.71	0.73	0.74	0.76	0.78	0.79	0.77	0.75	0.72	0.68
High	Black	CFM	2205	2150	2078	2011	1941	1852	1779	1672	1572	1473	
		BHP	1.04	1.02	0.99	0.95	0.92	0.87	0.85	0.79	0.75	0.70	

Shaded areas indicate speed/static combinations that are not permitted for dehumidification speed.

*Air delivery values are without air filter and are for dry coil (See Wet Coil Pressure Drop table).

¹ Factory-shipped cooling speed

NOTE: Deduct field-supplied air filter pressure drop and wet coil pressure drop to obtain external static pressure available for ducting.

Table 5 – Dry Coil Air Delivery* - Horizontal Discharge Sizes 36-60 3 Phase Models Only

Unit	Motor Speed	Wire Color		External Static Pressure (IN. W.C.)								
				0.1	0.2	0.3	0.4	0.5	0.6	0.7	0.8	0.9
36	Low	Blue	CFM	979	912	859	789	731	654	556	454	374
	Med-Low	Pink	CFM	1136	1080	1015	957	912	861	808	723	633
	Medium ¹	Red	CFM	1208	1144	1091	1025	964	902	886	830	746
	Med-High	Orange	CFM	1495	1439	1376	1303	1221	1207	1137	1052	981
	High	Black	CFM	1560	1491	1416	1337	1255	1233	1160	1082	998
42	Low	Blue	CFM	952	882	806	746	671	605	530	551	486
	Med-Low	Pink	CFM	1002	936	875	821	748	687	613	554	565
	Medium	Red	CFM	1255	1210	1145	1074	1008	940	878	895	838
	Med-High ¹	Orange	CFM	1335	1267	1246	1176	1109	1049	988	926	872
	High	Black	CFM	1472	1401	1326	1251	1275	1198	1139	1085	1023
48	Low	Blue	CFM	1402	1351	1311	1263	1224	1172	1136	1080	1041
	Med-Low	Pink	CFM	1457	1404	1367	1318	1284	1233	1197	1144	1104
	Medium ¹	Red	CFM	1736	1695	1642	1601	1553	1512	1465	1427	1381
	Med-High	Orange	CFM	2149	2111	2062	2026	1980	1945	1905	1864	1793
	High	Black	CFM	2344	2306	2259	2203	2141	2070	1991	1902	1803
60	Low	Blue	CFM	1445	1389	1341	1281	1236	1189	1139	1072	1027
	Med-Low	Pink	CFM	1678	1635	1602	1558	1513	1474	1438	1404	1349
	Medium ¹	Red	CFM	1962	1915	1880	1843	1794	1753	1711	1675	1628
	Med-High	Orange	CFM	2131	2088	2065	2013	1982	1941	1888	1860	1785
	High	Black	CFM	2461	2409	2339	2286	2192	2140	2062	1968	1874

Shaded areas indicate speed/static combinations that are not permitted for dehumidification speed.

*Air delivery values are without air filter and are for dry coil (See Wet Coil Pressure Drop table).

¹ Factory-shipped cooling speed

Note: Deduct field-supplied air filter pressure drop and wet coil pressure drop to obtain external static pressure available for ducting.

Table 6 – Dry Coil Air Delivery - Downflow Discharge Sizes 36-60 3 Phase Models Only

Unit	Motor Speed	Wire Color		External Static Pressure (IN. W.C.)									
				0.1	0.2	0.3	0.4	0.5	0.6	0.7	0.8	0.9	1.0
36	Low	Blue	CFM	979	912	859	789	731	654	556	454	374	255
			WATTS	202	212	217	221	231	236	245	251	259	253
			BHP	0.22	0.23	0.23	0.24	0.25	0.25	0.26	0.27	0.28	0.27
	Med-Low	Pink	CFM	1136	1080	1015	957	912	861	808	723	633	545
			WATTS	294	309	310	322	325	333	341	349	354	367
			BHP	0.32	0.33	0.33	0.35	0.35	0.36	0.37	0.37	0.38	
	Medium ¹	Red	CFM	1208	1144	1091	1025	964	902	886	830	746	663
			WATTS	345	350	358	366	373	377	390	396	407	410
			BHP	0.37	0.38	0.38	0.39	0.40	0.40	0.42	0.42	0.44	0.44
	Med-High	Orange	CFM	1495	1439	1376	1303	1221	1207	1137	1052	981	894
			WATTS	625	634	635	633	624	613	598	583	573	551
			BHP	0.67	0.68	0.68	0.68	0.67	0.66	0.64	0.63	0.61	0.59
	High	Black	CFM	1560	1491	1416	1337	1255	1233	1160	1082	998	911
			WATTS	708	699	683	674	660	634	624	606	581	566
			BHP	0.76	0.75	0.73	0.72	0.71	0.68	0.67	0.65	0.62	0.61
42	Low	Blue	CFM	952	882	806	746	671	605	530	551	486	435
			WATTS	124	134	140	150	156	166	171	182	188	198
			BHP	0.13	0.14	0.15	0.16	0.17	0.18	0.18	0.20	0.20	0.21
	Med-Low	Pink	CFM	1002	936	875	821	748	687	613	554	565	518
			WATTS	144	155	161	171	176	187	193	203	209	220
			BHP	0.15	0.17	0.17	0.18	0.19	0.20	0.21	0.22	0.22	0.24
	Medium	Red	CFM	1255	1210	1145	1074	1008	940	878	895	838	785
			WATTS	249	272	284	292	305	319	320	329	336	347
			BHP	0.27	0.29	0.30	0.31	0.33	0.34	0.34	0.35	0.36	0.37
	Med-High ¹	Orange	CFM	1335	1267	1246	1176	1109	1049	988	926	872	891
			WATTS	311	323	330	342	356	367	378	385	395	403
			BHP	0.33	0.35	0.35	0.37	0.38	0.39	0.41	0.41	0.42	0.43
	High	Black	CFM	1472	1401	1326	1251	1275	1198	1139	1085	1023	961
			WATTS	401	414	426	440	471	462	473	478	486	491
			BHP	0.43	0.44	0.46	0.47	0.51	0.50	0.51	0.51	0.52	0.53
48	Low	Blue	CFM	1503	1457	1423	1374	1330	1287	1241	1199	1153	1111
			WATTS	225	233	246	254	269	282	292	307	314	329
			BHP	0.24	0.25	0.26	0.27	0.29	0.30	0.31	0.33	0.34	0.35
	Med-Low	Pink	CFM	1556	1508	1461	1432	1388	1346	1302	1256	1221	1168
			WATTS	244	261	268	281	290	305	319	330	345	353
			BHP	0.26	0.28	0.29	0.30	0.31	0.33	0.34	0.35	0.37	0.38
	Medium ¹	Red	CFM	1861	1822	1786	1758	1716	1688	1660	1619	1583	1539
			WATTS	400	417	426	441	452	467	482	492	507	519
			BHP	0.43	0.45	0.46	0.47	0.48	0.50	0.52	0.53	0.54	0.56
	Med-High	Orange	CFM	2319	2291	2255	2230	2193	2166	2118	2057	1992	1887
			WATTS	758	769	787	799	808	823	822	805	780	737
			BHP	0.81	0.82	0.84	0.86	0.87	0.88	0.88	0.86	0.84	0.79
	High	Black	CFM	2532	2487	2444	2391	2330	2259	2179	2111	2033	1949
			WATTS	1014	1022	1015	994	965	935	898	858	823	786
			BHP	1.09	1.10	1.09	1.07	1.03	1.00	0.96	0.92	0.88	0.84

Table 6 – Dry Coil Air Delivery - Downflow Discharge Sizes 36-60 3 Phase Models Only (Continued)

Unit	Motor Speed	Wire Color		External Static Pressure (IN. W.C.)									
				0.1	0.2	0.3	0.4	0.5	0.6	0.7	0.8	0.9	1.0
60	Low	Blue	CFM	1479	1436	1387	1346	1298	1253	1206	1160	1114	1061
			WATTS	224	239	247	262	270	284	300	307	319	330
			BHP	0.24	0.26	0.26	0.28	0.29	0.30	0.32	0.33	0.34	0.35
	Med-Low	Pink	CFM	1841	1796	1761	1724	1690	1651	1616	1578	1527	1478
			WATTS	425	434	453	460	476	485	501	508	525	542
			BHP	0.46	0.47	0.49	0.49	0.51	0.52	0.54	0.54	0.56	0.58
	Medium ¹	Red	CFM	1944	1913	1872	1838	1801	1771	1731	1698	1655	1613
			WATTS	486	501	511	529	537	554	565	578	595	603
			BHP	0.52	0.54	0.55	0.57	0.58	0.59	0.61	0.62	0.64	0.65
	Med-High	Orange	CFM	2178	2148	2105	2073	2036	2002	1967	1919	1845	1751
			WATTS	674	691	703	717	733	743	758	754	734	701
			BHP	0.72	0.74	0.75	0.77	0.79	0.80	0.81	0.81	0.79	0.75
	High	Black	CFM	2480	2432	2375	2322	2236	2161	2085	2006	1917	1808
			WATTS	1029	1012	995	975	941	908	869	836	796	751
			BHP	1.10	1.09	1.07	1.05	1.01	0.97	0.93	0.90	0.85	0.81

Shaded areas indicate speed/static combinations that are not permitted for dehumidification speed.

*Air delivery values are without air filter and are for dry coil (See Wet Coil Pressure Drop table).

¹ Factory-shipped cooling speed

NOTE: Deduct field-supplied air filter pressure drop and wet coil pressure drop to obtain external static pressure available for ducting.

Table 7 – Wet Coil Pressure Drop (IN. W.C.)

Unit Size	Standard CFM (SCFM)																
	600	700	800	900	1000	1100	1200	1300	1400	1500	1600	1700	1800	1900	2000	2100	2200
24	0.03	0.04	0.04	0.05	0.06												
30				0.05	0.06	0.07	0.08	0.11									
36				0.06	0.06	0.09	0.10	0.11	0.14								
42					0.05	0.05	0.06	0.07	0.08	0.08	0.09	0.09	0.11				
48							0.04	0.06	0.09	0.10	0.10	0.11	0.12	0.13	0.14		
60										0.06	0.07	0.01	0.08	0.09	0.10	0.12	0.13

Table 8 – Economizer with 1-in. Filter Pressure Drop (IN. W.C.)

Filter Size in. (mm)	Cooling Tons	Standard CFM (SCFM)																
		600	700	800	900	1000	1100	1200	1300	1400	1500	1600	1700	1800	1900	2000	2100	2200
600-1400CFM 12x20x1+12x20x1 (305x508x25+305x508x25)	2.0, 2.5, 3.0	-	-	0.09	0.14	0.16	0.18	0.25	0.28	0.3	-	-	-	-	-	-	-	
1200-1800 CFM 16x24x1+14x24x1 (406x610x25+356x610x25)	3.5, 4.0	-	-	-	-	-	-	0.10	0.11	0.12	0.13	0.14	0.16	0.16	-	-	-	
1500-2200 CFM 16x24x1+18x24x1 (406x610x25+457x610x25)	5.0	-	-	-	-	-	-	-	-	-	0.15	0.17	0.18	0.20	0.21	0.22	0.23	

Table 9 – Filter Pressure Drop Table (IN. W.C.)

Filter Size in. (mm)	Cooling Tons	Standard CFM (SCFM)																
		600	700	800	900	1000	1100	1200	1300	1400	1500	1600	1700	1800	1900	2000	2100	2200
600-1400CFM 12x20x1+12x20x1 (305x508x25+305x508x25)	2.0, 2.5, 3.0	0.03	0.05	0.06	0.08	0.10	0.11	0.13	0.14	0.16	-	-	-	-	-	-	-	-
1200-1800 CFM 16x24x1+14x24x1 (406x610x25+356x610x25)	3.5, 4.0	-	-	-	-	-	-	0.07	0.08	0.09	0.09	0.10	0.11	0.12	-	-	-	-
1500-2200 CFM 16x24x1+18x24x1 (406x610x25+457x610x25)	5.0	-	-	-	-	-	-	-	-	-	0.04	0.06	0.08	0.10	0.11	0.13	0.14	0.15

**Table 10 – Electric Heat Pressure Drop Table (IN. W.C.)
Small Cabinet: 24-36**

STATIC	STANDARD CFM (SCFM)												
	500	600	700	800	900	1000	1100	1200	1300	1400	1500	1600	
5 kW	0.00	0.00	0.00	0.00	0.00	0.00	0.00	0.00	0.02	0.04	0.06	0.07	
10 kW	0.00	0.00	0.00	0.00	0.00	0.02	0.04	0.06	0.07	0.09	0.10	0.11	
15 kW	0.00	0.00	0.00	0.02	0.04	0.06	0.08	0.10	0.12	0.14	0.16	0.18	
20 kW	0.00	0.00	0.02	0.04	0.06	0.08	0.09	0.11	0.13	0.15	0.17	0.19	

**Table 11 – Electric Heat Pressure Drop Table (IN. W.C.)
Large Cabinet: 42-60**

STATIC	STANDARD CFM (SCFM)														
	1100	1200	1300	1400	1500	1600	1700	1800	1900	2000	2100	2200	2300	2400	2500
5 kW	0.00	0.00	0.00	0.01	0.02	0.03	0.04	0.05	0.06	0.07	0.08	0.09	0.10	0.11	0.12
10 kW	0.00	0.00	0.01	0.02	0.03	0.04	0.05	0.06	0.07	0.08	0.09	0.10	0.11	0.12	0.13
15 kW	0.00	0.02	0.03	0.04	0.05	0.06	0.07	0.08	0.09	0.10	0.11	0.12	0.13	0.14	0.15
20 kW	0.02	0.03	0.04	0.05	0.06	0.07	0.08	0.09	0.10	0.11	0.12	0.13	0.14	0.15	0.16

Manufacturer reserves the right to change, at any time, specifications and designs without notice and without obligations.

CONNECTION WIRING DIAGRAM
DANGER: ELECTRICAL SHOCK HAZARD DISCONNECT POWER BEFORE SERVICING

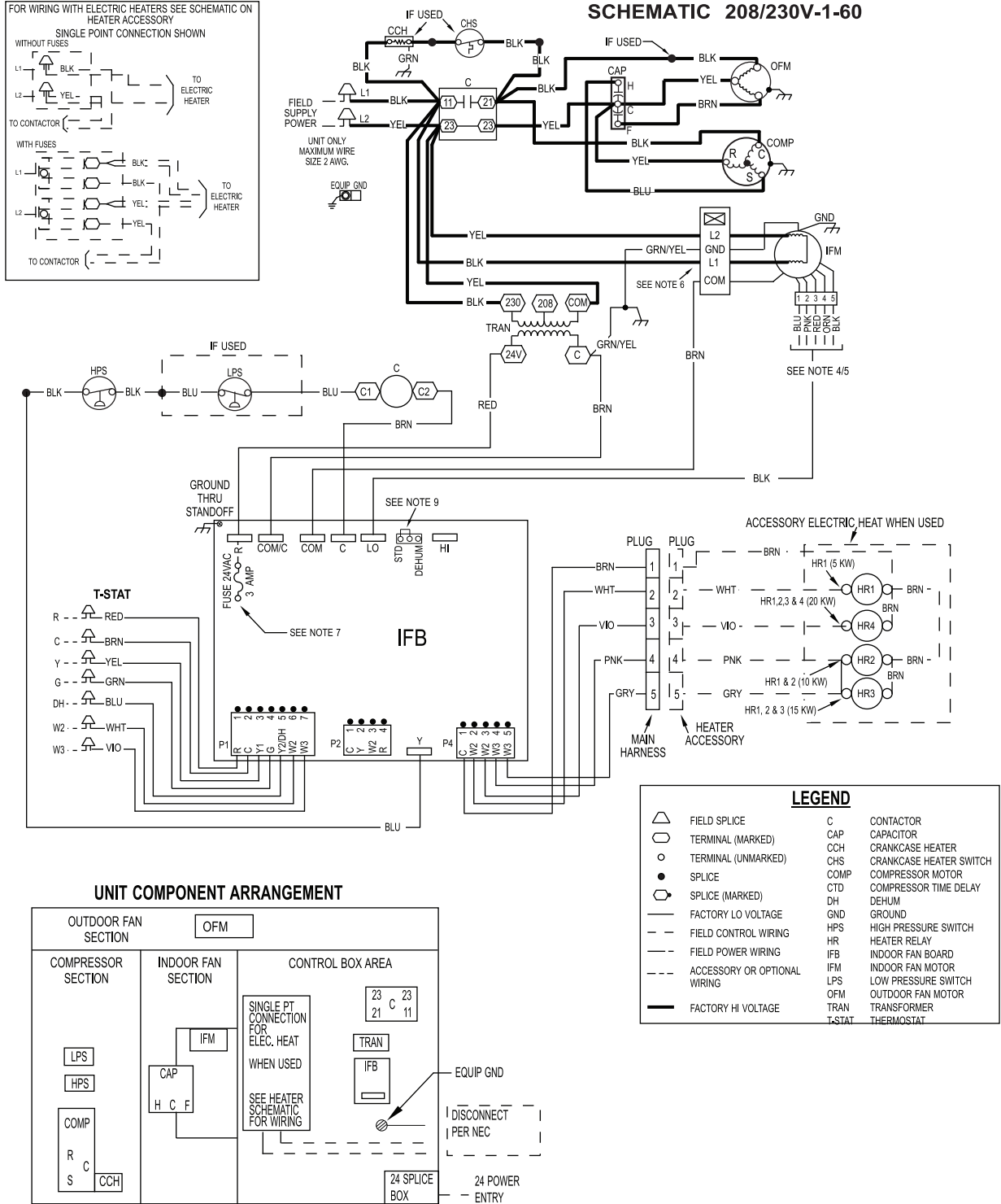
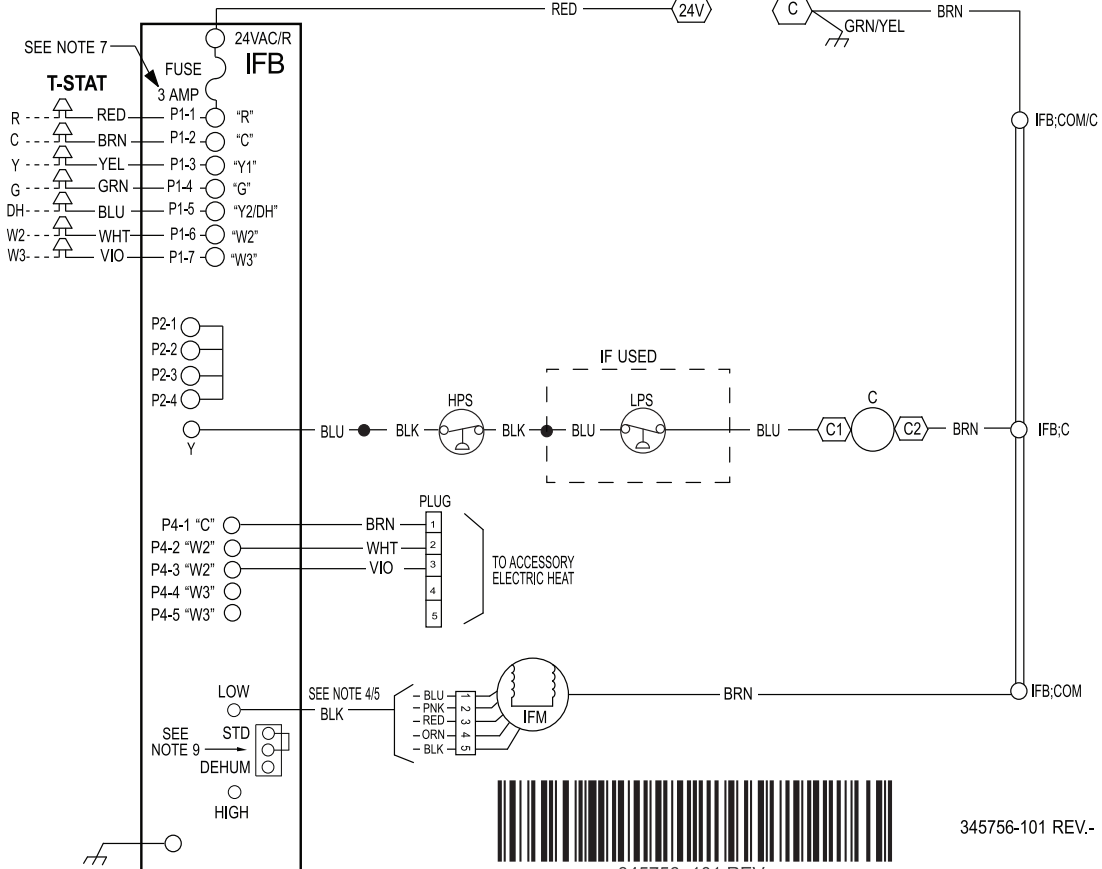
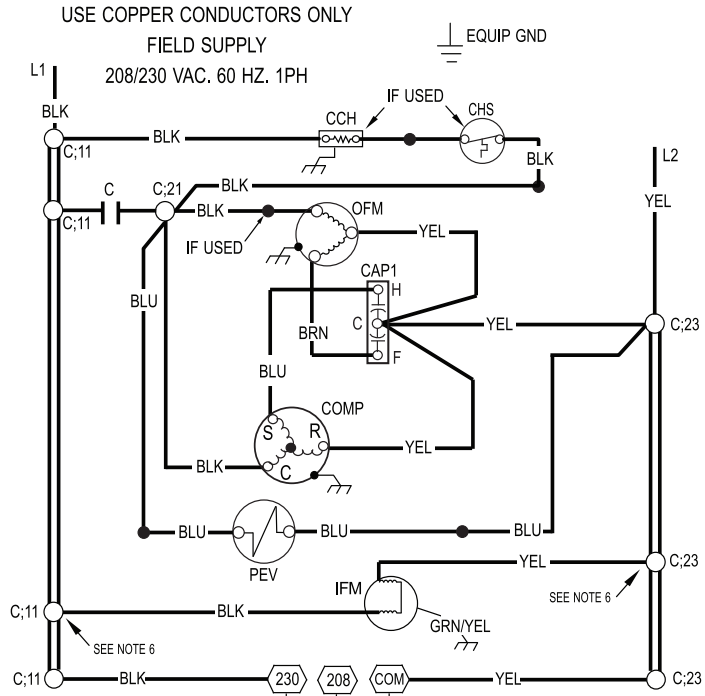
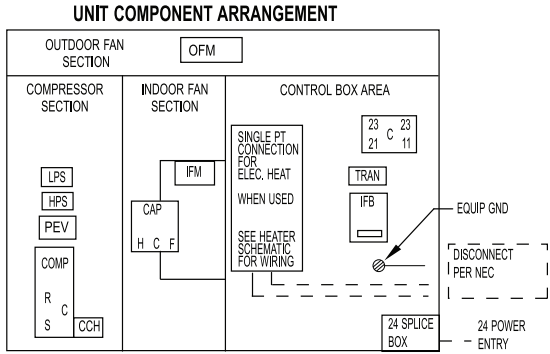

Fig. 12 – Connection Wiring Diagram 24, 36-60 Size 208/230-1-60

LADDER WIRING DIAGRAM

DANGER: ELECTRICAL SHOCK HAZARD DISCONNECT POWER BEFORE SERVICING



345756-101 REV.-



Fig. 15 – Ladder Wiring Diagram 30 Size 208/230-1-60

CONNECTION WIRING DIAGRAM
DANGER: ELECTRICAL SHOCK HAZARD DISCONNECT POWER BEFORE SERVICING

SCHEMATIC 208/230V-3-60

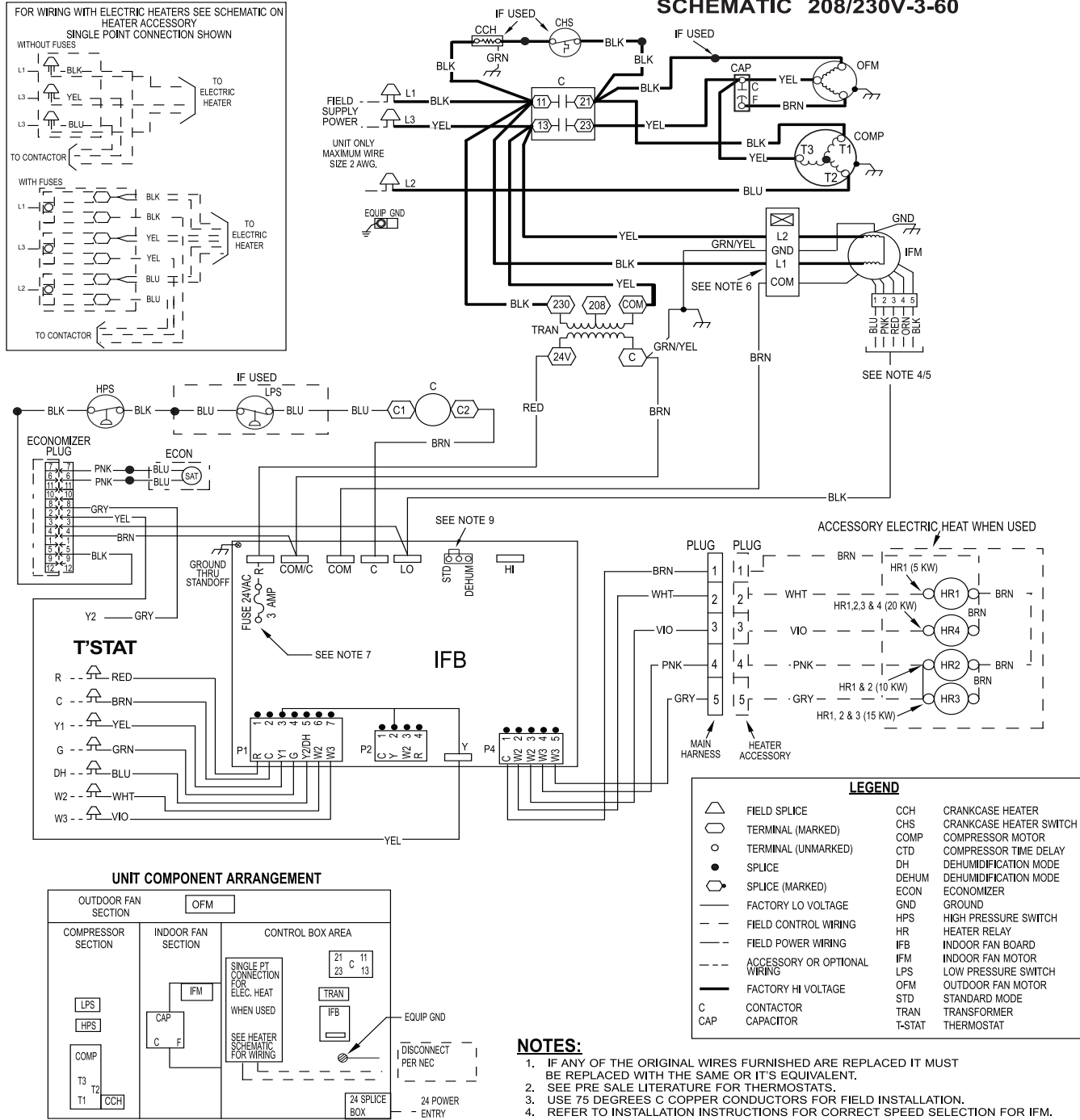

- NOTES:**
- IF ANY OF THE ORIGINAL WIRES FURNISHED ARE REPLACED IT MUST BE REPLACED WITH THE SAME OR IT'S EQUIVALENT.
 - SEE PRE SALE LITERATURE FOR THERMOSTATS.
 - USE 75 DEGREES C COPPER CONDUCTORS FOR FIELD INSTALLATION.
 - REFER TO INSTALLATION INSTRUCTIONS FOR CORRECT SPEED SELECTION FOR IFM.
 - RELOCATION OF SPEED TAPS MAY BE REQUIRED WHEN USING FIELD INSTALLED ELECTRIC HEATERS. CONSULT INSTALLATION INSTRUCTIONS TO DETERMINE CORRECT SPEED TAP SETTING.
 - "DO NOT DISCONNECT PLUG UNDER LOAD".
 - THIS FUSE IS MANUFACTURED BY LITTLE FUSE, P/N 287003.
 - N.E.C. CLASS 2, 24V.
 - DEHUM FEATURE CANNOT BE USED WHEN ECONOMIZER IS INSTALLED. UNIT FACTORY - SHIPPED IN STD MODE.
 - CCH NOT USED ON ALL UNITS.

A150504

Fig. 16 – Connection Wiring Diagram 208/230-3-60

CONNECTION WIRING DIAGRAM
DANGER: ELECTRICAL SHOCK HAZARD DISCONNECT POWER BEFORE SERVICING

SCHEMATIC 460-3-60

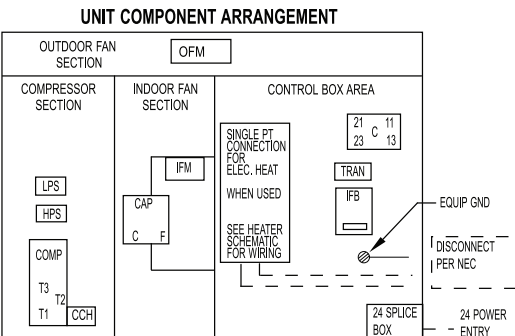
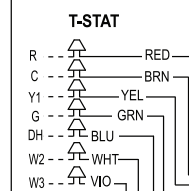
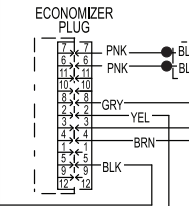
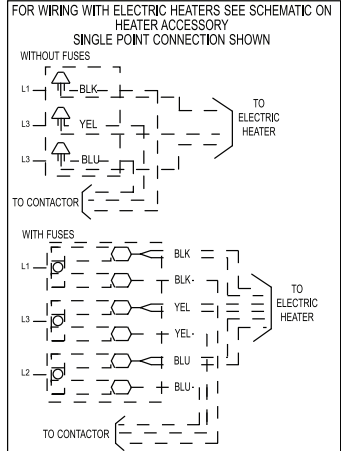
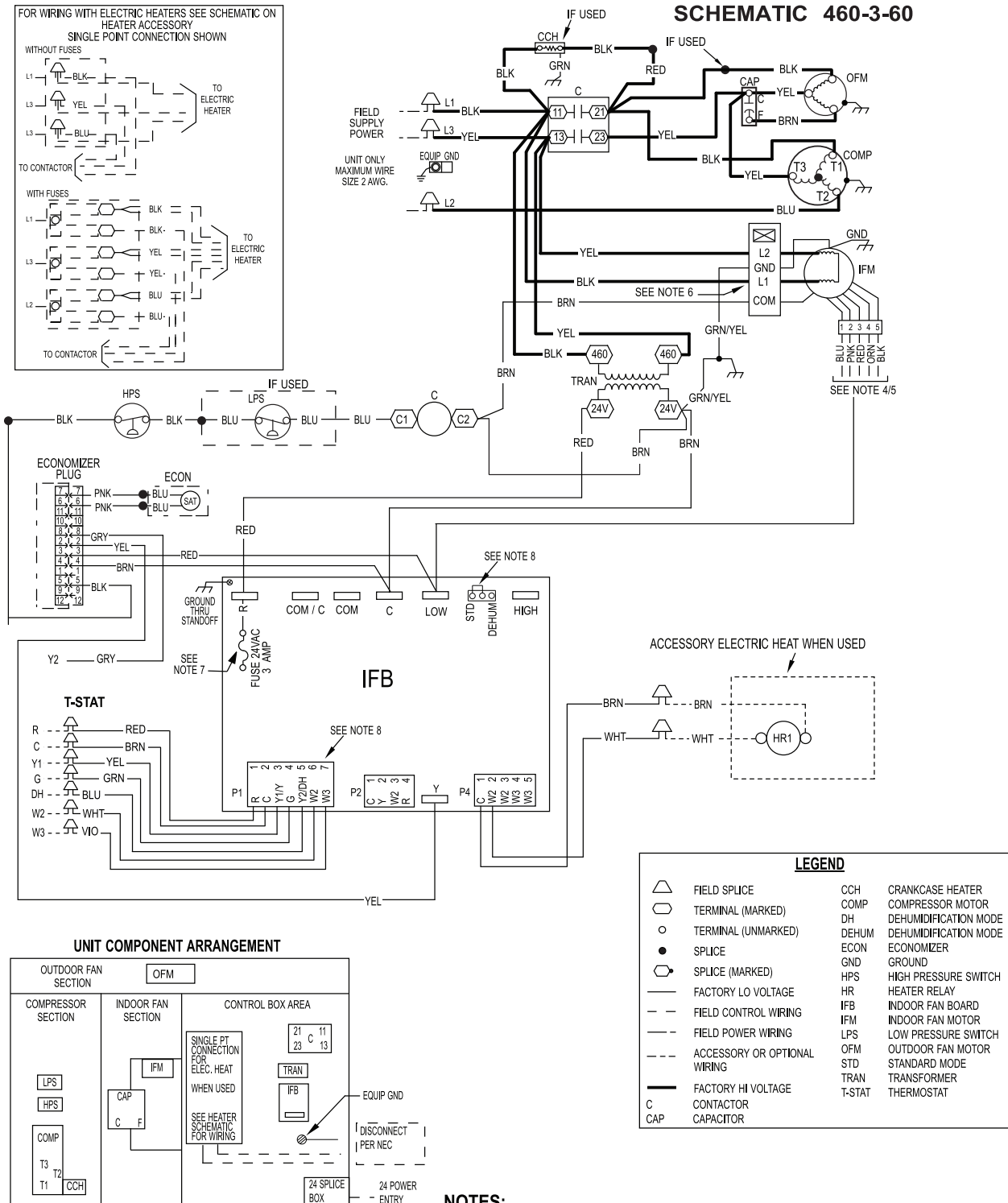

LEGEND

	FIELD SPLICE		CCH	CRANKCASE HEATER
	TERMINAL (MARKED)		COMP	COMPRESSOR MOTOR
	TERMINAL (UNMARKED)		DH	DEHUMIDIFICATION MODE
	SPLICE		DEHUM	DEHUMIDIFICATION MODE
	SPLICE (MARKED)		ECON	ECONOMIZER
	FACTORY LO VOLTAGE		GND	GROUND
	FIELD CONTROL WIRING		HPS	HIGH PRESSURE SWITCH
	FIELD POWER WIRING		HR	HEATER RELAY
	ACCESSORY OR OPTIONAL WIRING		IFB	INDOOR FAN BOARD
	FACTORY HI VOLTAGE		IFM	INDOOR FAN MOTOR
	CONTACTOR		LPS	LOW PRESSURE SWITCH
	CAPACITOR		OFM	OUTDOOR FAN MOTOR
			STD	STANDARD MODE
			TRAN	TRANSFORMER
			T-STAT	THERMOSTAT

- NOTES:**
- IF ANY OF THE ORIGINAL WIRES FURNISHED ARE REPLACED IT MUST BE REPLACED WITH THE SAME OR IT'S EQUIVALENT.
 - SEE PRE SALE LITERATURE FOR THERMOSTATS.
 - USE 75 DEGREES C COPPER CONDUCTORS FOR FIELD INSTALLATION.
 - REFER TO INSTALLATION INSTRUCTIONS FOR CORRECT SPEED SELECTION FOR IFM.
 - RELOCATION OF SPEED TAPS MAY BE REQUIRED WHEN USING FIELD INSTALLED ELECTRIC HEATERS. CONSULT INSTALLATION INSTRUCTIONS TO DETERMINE CORRECT SPEED TAP SETTING.
 - "DO NOT DISCONNECT PLUG UNDER LOAD".
 - THIS FUSE IS MANUFACTURED BY LITTLE FUSE, P/N 287003.
 - DEHUM FEATURE CANNOT BE USED WHEN ECONOMIZER IS INSTALLED. UNIT FACTORY - SHIPPED IN STD MODE.
 - N.E.C. CLASS 2, 24V.
 - CCH NOT USED ON ALL UNITS.

Fig. 18 – Connection Wiring Diagram 460-3-60

SUPERHEAT CHARGING TABLE (SUPERHEAT °F (°C) AT COMPRESSOR SUCTION SERVICE PORT)														COOLING ONLY CHARGING PROCEDURE
OUTDOOR TEMP °F (°C)	EVAPORATOR ENTERING AIR °F (°C) WB													
	50 (10)	52 (11)	54 (12)	56 (13)	58 (14)	60 (16)	62 (17)	64 (18)	66 (19)	68 (20)	70 (21)	72 (22)	74 (23)	76 (24)
55 (12.7)	9 (5.0)	12 (6.7)	14 (7.8)	17 (9.4)	20 (11)	23 (13)	26 (14)	29 (16)	32 (18)	35 (19)	37 (21)	40 (22)	42 (23)	45 (25)
60 (15.6)	7 (3.9)	10 (5.6)	12 (6.7)	15 (8.3)	18 (10)	21 (12)	24 (13)	27 (15)	30 (17)	33 (18)	35 (19)	38 (21)	40 (22)	43 (24)
65 (18.3)	--	6 (3.3)	10 (5.6)	13 (7.2)	16 (8.9)	19 (11)	21 (12)	24 (13)	27 (15)	30 (17)	33 (18)	36 (20)	38 (21)	41 (23)
70 (21.1)	--	--	7 (3.9)	10 (5.6)	13 (7.2)	16 (8.9)	19 (11)	21 (12)	24 (13)	27 (15)	30 (17)	33 (18)	36 (20)	39 (22)
75 (23.9)	--	--	--	6 (3.3)	9 (5.0)	12 (6.7)	15 (8.3)	18 (10)	21 (12)	24 (13)	28 (16)	31 (17)	34 (19)	37 (21)
80 (26.7)	--	--	--	--	5 (2.8)	8 (4.4)	12 (6.7)	15 (8.3)	18 (10)	21 (12)	25 (14)	28 (16)	31 (17)	35 (19)
85 (29.4)	--	--	--	--	--	--	8 (4.4)	11 (6.1)	15 (8.3)	19 (11)	22 (12)	26 (14)	30 (17)	33 (18)
90 (32.2)	--	--	--	--	--	--	5 (2.8)	9 (5.0)	13 (7.2)	16 (8.9)	20 (11)	24 (13)	27 (15)	31 (17)
95 (35.0)	--	--	--	--	--	--	--	6 (3.3)	10 (5.6)	14 (7.8)	18 (10)	22 (12)	25 (14)	29 (16)
100 (37.7)	--	--	--	--	--	--	--	8 (4.4)	12 (6.7)	15 (8.3)	20 (11)	23 (13)	27 (15)	--
105 (40.6)	--	--	--	--	--	--	--	--	5 (2.8)	9 (5.0)	13 (7.2)	17 (9.4)	22 (12)	26 (14)
110 (43.3)	--	--	--	--	--	--	--	--	--	6 (3.3)	11 (6.1)	15 (8.3)	20 (11)	25 (14)
115 (46.1)	--	--	--	--	--	--	--	--	--	--	8 (4.4)	14 (7.8)	18 (10)	23 (13)

REQUIRED SUCTION TUBE TEMPERATURE °F (°C) (MEASURED AT COMPRESSOR SUCTION SERVICE PORT)										
SUPERHEAT TEMP °F (°C)	SUCTION PRESSURE AT SUCTION SERVICE PORT PSIG (kPa)									
	107 (738)	111 (766)	116 (800)	120 (828)	125 (862)	130 (897)	135 (931)	140 (966)	145 (1000)	
0 (0)	35 (1.7)	37 (2.8)	39 (3.9)	41 (5.0)	43 (6.1)	45 (7.2)	47 (8.3)	49 (9.4)	51 (11)	53 (12)
2 (1.1)	37 (2.8)	39 (3.9)	41 (5.0)	43 (6.1)	45 (7.2)	47 (8.3)	49 (9.4)	51 (11)	53 (12)	55 (13)
4 (2.2)	39 (3.9)	41 (5.0)	43 (6.1)	45 (7.2)	47 (8.3)	49 (9.4)	51 (11)	53 (12)	55 (13)	57 (14)
6 (3.3)	41 (5.0)	43 (6.1)	45 (7.2)	47 (8.3)	49 (9.4)	51 (11)	53 (12)	55 (13)	57 (14)	59 (15)
8 (4.4)	43 (6.1)	45 (7.2)	47 (8.3)	49 (9.4)	51 (11)	53 (12)	55 (13)	57 (14)	59 (15)	61 (16)
10 (5.6)	45 (7.2)	47 (8.3)	49 (9.4)	51 (11)	53 (12)	55 (13)	57 (14)	59 (15)	61 (16)	63 (17)
12 (6.7)	47 (8.3)	49 (9.4)	51 (11)	53 (12)	55 (13)	57 (14)	59 (15)	61 (16)	63 (17)	65 (18)
14 (7.8)	49 (9.4)	51 (11)	53 (12)	55 (13)	57 (14)	59 (15)	61 (16)	63 (17)	65 (18)	67 (19)
16 (8.9)	51 (11)	53 (12)	55 (13)	57 (14)	59 (15)	61 (16)	63 (17)	65 (18)	67 (19)	69 (21)
18 (10.0)	53 (12)	55 (13)	57 (14)	59 (15)	61 (16)	63 (17)	65 (18)	67 (19)	69 (21)	71 (22)
20 (11.1)	55 (13)	57 (14)	59 (15)	61 (16)	63 (17)	65 (18)	67 (19)	69 (21)	71 (22)	73 (23)
22 (12.2)	57 (14)	59 (15)	61 (16)	63 (17)	65 (18)	67 (19)	69 (21)	71 (22)	73 (23)	75 (24)
24 (13.3)	59 (15)	61 (16)	63 (17)	65 (18)	67 (19)	69 (21)	71 (22)	73 (23)	75 (24)	77 (25)
26 (14.4)	61 (16)	63 (17)	65 (18)	67 (19)	69 (21)	71 (22)	73 (23)	75 (24)	77 (25)	79 (26)
28 (15.6)	63 (17)	65 (18)	67 (19)	69 (21)	71 (22)	73 (23)	75 (24)	77 (25)	79 (26)	81 (27)
30 (16.7)	65 (18)	67 (19)	69 (21)	71 (22)	73 (23)	75 (24)	77 (25)	79 (26)	81 (27)	83 (28)
32 (17.8)	67 (19)	69 (21)	71 (22)	73 (23)	75 (24)	77 (25)	79 (26)	81 (27)	83 (28)	85 (29)
34 (18.9)	69 (21)	71 (22)	73 (23)	75 (24)	77 (25)	79 (26)	81 (27)	83 (28)	85 (29)	87 (31)
36 (20.0)	71 (22)	73 (23)	75 (24)	77 (25)	79 (26)	81 (27)	83 (28)	85 (29)	87 (31)	89 (32)
38 (21.1)	73 (23)	75 (24)	77 (25)	79 (26)	81 (27)	83 (28)	85 (29)	87 (31)	89 (32)	91 (33)
40 (22.2)	75 (24)	77 (25)	79 (26)	81 (27)	83 (28)	85 (29)	87 (31)	89 (32)	91 (33)	93 (34)

50ZH500518 REV. A

50ZH500518 REV. A

- Operate unit a minimum of 10 minutes before charging.
- Measure suction pressure by attaching an accurate gauge to compressor suction side service port.
- Measure suction side temperature by attaching an accurate thermistor type or electronic thermometer to suction line about 10 inches from compressor.
- Measure outdoor air dry-bulb temperature with thermometer.
- Measure indoor air (return air) wet-bulb temperature with a sling psychrometer or electronic equivalent.
- Using Superheat Charging Table find outdoor temperature and indoor air wet-bulb temperature. At this intersection note superheat. Where a dash (-) appears on table do not attempt to charge unit under these conditions or refrigerant slugging may occur. In this situation refrigerant must be evacuated and weighed in. See rating plate for charge quantity.
- Refer to Required Suction Tube Temp. table. Find superheat temperature located in step 6 and suction pressure. At this intersection note suction line temperature.
- If unit has a higher suction line temperature than charted temperature, add refrigerant until charted temperature is reached.
- If unit has a lower suction line temperature than charted temperature, reclaim refrigerant until charted temperature is reached.
- If outdoor air temperature or pressure at suction port changes, charge to new suction line temperature indicated on chart.

Superheat charging table is derived from optimum performance point. (95°F [35°C] outdoor ambient and (80°F [27°C] dry bulb; 67°F [19°C] wet bulb indoor condition.) Where a dash(--) appears do not attempt to check charge or charge unit under these conditions using the superheat method. (Weigh in method should be used.)

A150625

Model Size	Required Subcooling °F(°C)					Pressure (psig)	Required Subcooling (°F)					Pressure (kPa)	Required Subcooling (°C)				
	Outdoor Ambient Temperature °F(°C)						5	10	15	20	25		3	6	8	11	14
	75 (24)	85 (29)	95 (35)	105 (41)	115 (46)												
036	13 (7)	13 (7.2)	13 (7.3)	13(7.4)	14(7.7)	189	61	56	51	46	41	1303	16	13	11	8	5
						196	63	58	53	48	43	1351	17	15	12	9	6
						203	66	61	56	51	46	1399	19	16	13	10	8
						210	68	63	58	53	48	1448	20	17	14	11	9
						217	70	65	60	55	50	1496	21	18	15	13	10
						224	72	67	62	57	52	1544	22	19	16	14	11
						231	74	69	64	59	54	1593	23	20	18	15	12
						238	76	71	66	61	56	1641	24	21	19	16	13
						245	77	72	67	62	57	1689	25	22	20	17	14
						252	79	74	69	64	59	1737	26	23	21	18	15
						260	81	76	71	66	61	1792	27	25	22	19	16
						268	83	78	73	68	63	1848	29	26	23	20	17
						276	85	80	75	70	65	1903	30	27	24	21	19
						284	87	82	77	72	67	1958	31	28	25	22	20
						292	89	84	79	74	69	2013	32	29	26	23	21
						300	91	86	81	76	71	2068	33	30	27	24	22
						309	93	88	83	78	73	2130	34	31	28	26	23
						318	95	90	85	80	75	2192	35	32	29	27	24
						327	97	92	87	82	77	2254	36	33	31	28	25
						336	99	94	89	84	79	2316	37	34	32	29	26
						345	101	96	91	86	81	2378	38	35	33	30	27
						354	103	98	93	88	83	2440	39	36	34	31	28
						364	105	100	95	90	85	2509	40	38	35	32	29
						374	107	102	97	92	87	2578	41	39	36	33	30
						384	108	103	98	93	88	2647	42	40	37	34	31
						394	110	105	100	95	90	2716	44	41	38	35	32
						404	112	107	102	97	92	2785	45	42	39	36	33
						414	114	109	104	99	94	2854	46	43	40	37	34
						424	116	111	106	101	96	2923	47	44	41	38	35
						434	118	113	108	103	98	2992	48	45	42	39	36
						444	119	114	109	104	99	3061	48	46	43	40	37
						454	121	116	111	106	101	3130	49	47	44	41	38
						464	123	118	113	108	103	3199	50	48	45	42	39
						474	124	119	114	109	104	3268	51	48	46	43	40
						484	126	121	116	111	106	3337	52	49	47	44	41
						494	127	122	117	112	107	3406	53	50	47	45	42
						504	129	124	119	114	109	3475	54	51	48	46	43
						514	131	126	121	116	111	3544	55	52	49	46	44
						524	132	127	122	117	112	3612	56	53	50	47	45
						534	134	129	124	119	114	3681	56	54	51	48	45

50VL500709 REV. -

50VL500709 REV. -

To properly check or adjust charge, conditions must be favorable for subcooling charging. Favorable conditions exist when the outdoor temperature is between 75°F to 115°F (24°C and 46°C), and the indoor temperature is between 70°F and 80°F (21°C and 27°C). Follow the procedure above.

A150626

Fig. 20 – Cooling Charging Chart

Maintenance

To ensure continuing high performance, and to minimize the possibility of premature equipment failure, periodic maintenance must be performed on this equipment. This cooling unit should be inspected at least once each year by a qualified service person. To troubleshoot unit, refer to [Table 12](#), Troubleshooting Chart.

NOTE TO EQUIPMENT OWNER: Consult your local dealer about the availability of a maintenance contract.

WARNING

PERSONAL INJURY AND UNIT DAMAGE HAZARD

Failure to follow this warning could result in personal injury or death and possible unit component damage.

The ability to properly perform maintenance on this equipment requires certain expertise, mechanical skills, tools and equipment. If you do not possess these, do not attempt to perform any maintenance on this equipment, other than those procedures recommended in the Owner's Manual.

WARNING

ELECTRICAL SHOCK AND FIRE HAZARD

Failure to follow these warnings could result in personal injury or death:

1. Turn off electrical power to the unit and install lockout tag before performing any maintenance or service on this unit.
2. Use extreme caution when removing panels and parts.
3. Never place anything combustible either on or in contact with the unit.

CAUTION

UNIT OPERATION HAZARD

Failure to follow this caution may result in equipment damage or improper operation.

Errors made when reconnecting wires may cause improper and dangerous operation. Label all wires prior to disconnecting when servicing.

The minimum maintenance requirements for this equipment are as follows:

1. Inspect air filter(s) each month. Clean or replace when necessary.
2. Inspect indoor coil, drain pan, and condensate drain each cooling season for cleanliness. Clean when necessary.
3. Inspect blower motor and wheel for cleanliness each cooling season. Clean when necessary.
4. Check electrical connections for tightness and controls for proper operation each cooling season. Service when necessary.
5. Ensure electric wires are not in contact with refrigerant tubing or sharp metal edges.

Air Filter

IMPORTANT: Never operate the unit without a suitable air filter in the return-air duct system. Always replace the filter with the same dimensional size and type as originally installed. See [Table 1](#) for recommended filter sizes.

Inspect air filter(s) at least once each month and replace (throwaway-type) or clean (cleanable-type) at least twice during each

cooling season and twice during the heating season, or whenever the filter becomes clogged with dust and lint.

Indoor Blower and Motor

NOTE: All motors are pre-lubricated. Do not attempt to lubricate these motors.

For longer life, operating economy, and continuing efficiency, clean accumulated dirt and grease from the blower wheel and motor annually.

WARNING

ELECTRICAL SHOCK HAZARD

Failure to follow this warning could result in personal injury or death. Disconnect and tag electrical power to the unit before cleaning the blower motor and wheel.

To clean the blower motor and wheel:

1. Remove and disassemble blower assembly as follows:
 - a. Remove blower access panel (see [Fig. 22](#)).
 - b. Disconnect 5 pin plug and 4 pin plug from indoor blower motor. Remove capacitor if required.
 - c. On all units remove blower assembly from unit. Remove screws securing blower to blower partition and slide assembly out. Be careful not to tear insulation in blower compartment.
 - d. Ensure proper reassembly by marking blower wheel and motor in relation to blower housing before disassembly.
 - e. Loosen setscrew(s) that secures wheel to motor shaft, remove screws that secure motor mount brackets to housing, and slide motor and motor mount out of housing.
2. Remove and clean blower wheel as follows:
 - a. Ensure proper reassembly by marking wheel orientation.
 - b. Lift wheel from housing. When handling and/or cleaning blower wheel, be sure not to disturb balance weights (clips) on blower wheel vanes.
 - c. Remove caked-on dirt from wheel and housing with a brush. Remove lint and/or dirt accumulations from wheel and housing with vacuum cleaner, using soft brush attachment. Remove grease and oil with mild solvent.
 - d. Reassemble wheel into housing.
 - e. Reassemble motor into housing. Be sure setscrews are tightened on motor shaft flats and not on round part of shaft. Reinstall blower into unit.
 - f. Connect 5 pin plug and 4 pin plug to indoor blower motor. Reinstall capacitor if required.
 - g. Reinstall blower access panel (see [Fig. 22](#)).
3. Restore electrical power to unit. Start unit and check for proper blower rotation and motor speeds during cooling cycles.

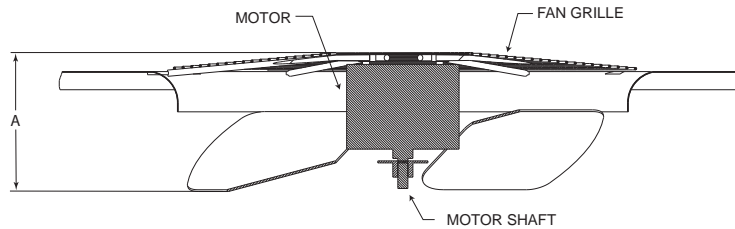

A08505

MAX DISTANCE BETWEEN TOP OF FAN GRILLE AND BOTTOM OF FAN BLADE

Size	"A"	
	IN.	mm
24	9.0	228
30	7.1	180
36	8.0	203
42	7.6	193
48	7.6	193
60	7.6	193

Fig. 21 – Fan Blade Position

Outdoor Fan

! CAUTION

UNIT OPERATION HAZARD

Failure to follow this caution may result in damage to unit components. Keep the condenser fan free from all obstructions to ensure proper cooling operation. Never place articles on top of the unit.

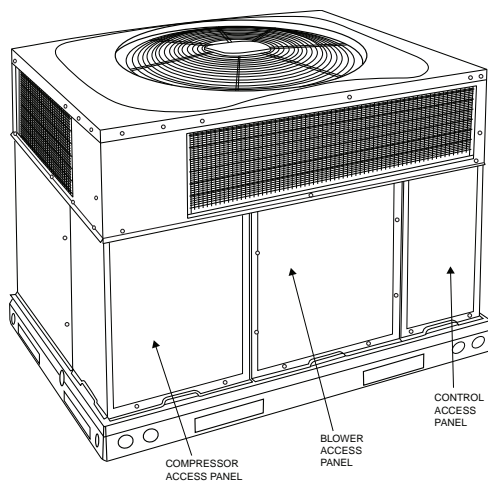

A170032

Fig. 22 – Unit Access Panels

Outdoor Coil, Indoor Coil, and Condensate Drain Pan

Inspect the condenser coil, evaporator coil, and condensate drain pan at least once each year.

The coils are easily cleaned when dry; therefore, inspect and clean the coils either before or after each cooling season. Remove all obstructions, including weeds and shrubs, that interfere with the airflow through the condenser coil.

Straighten bent fins with a fin comb. If coated with dirt or lint, clean the coils with a vacuum cleaner, using the soft brush attachment. Be careful not to bend the fins. If coated with oil or grease, clean the coils with a mild detergent and water solution. Rinse coils with clear water, using a garden hose. Be careful not to splash water on motors, insulation, wiring, or air filter(s). For best results, spray condenser coil fins from inside to outside the unit. On units with an outer and inner condenser coil, be sure to clean between the coils. Be sure to flush all dirt and debris from the unit base.

Inspect the drain pan and condensate drain line when inspecting the coils. Clean the drain pan and condensate drain by removing all foreign matter from the pan. Flush the pan and drain trough with clear water. Do not splash water on the insulation, motor, wiring, or air filter(s). If the drain trough is restricted, clear it with a “plumbers snake” or similar probe device.

1. Remove 6 screws holding condenser grille and motor to top cover.
2. Turn motor/grille assembly upside down on top cover to expose the fan blade.
3. Inspect the fan blades for cracks or bends.
4. If fan needs to be removed, loosen the setscrew and slide the fan off the motor shaft.
5. When replacing fan blade, position blade as shown in Fig. 21.
6. Ensure that setscrew engages the flat area on the motor shaft when tightening
7. Replace grille.

Electrical Controls and Wiring

Inspect and check the electrical controls and wiring annually. Be sure to turn off the electrical power to the unit.

Remove access panels (see Fig. 22) to locate all the electrical controls and wiring. Check all electrical connections for tightness. Tighten all screw connections. If any smoky or burned connections are noticed, disassemble the connection, clean all the parts, restrip the wire end and reassemble the connection properly and securely.

After inspecting the electrical controls and wiring, replace the access panels (see Fig. 22). Start the unit, and observe at least one complete heating cycle and one complete cooling cycle to ensure proper operation. If discrepancies are observed in either or both operating cycles, or if a suspected malfunction has occurred, check each electrical component with the proper electrical instrumentation. Refer to the unit wiring label when making these checkouts.

NOTE: Refer to the heating and/or cooling sequence of operation in this publication as an aid in determining proper control operation

Refrigerant Circuit

Inspect all refrigerant tubing connections.

WARNING

EXPLOSION, SAFETY AND ENVIRONMENTAL HAZARD

Failure to follow this warning could result in personal injury, death or equipment damage.

This system uses Puron (R-410A) refrigerant which has higher operating pressures than R-22 and other refrigerants. No other refrigerant may be used in this system. Gauge set, hoses, and recovery system must be designed to handle Puron (R-410A). If you are unsure, consult the equipment manufacturer.

If low cooling performance is suspected, leak-test all refrigerant tubing using an electronic leak-detector or liquid-soap solution. If a refrigerant leak is detected, refer to the Check for Refrigerant Leaks section.

If no refrigerant leaks are found and low cooling performance is suspected, refer to the Checking and Adjusting Refrigerant Charge section.

Evaporator Airflow

The heating and/or cooling air-flow does not require checking unless improper performance is suspected. If a problem exists, be sure that all supply- and return-air grilles are open and free from obstructions, and that the air filter is clean. When necessary, refer to Indoor Airflow and Airflow Adjustments section to check the system airflow.

Puron (R-410A) Items

The indoor metering device is either a TXV or orifice type device depending on size.

Pressure Switches

Pressure switches are protective devices wired into the control circuit (low voltage). They shut off compressor if abnormally high or low pressures are present in the refrigeration circuit. These pressure switches are specifically designed to operate with Puron (R-410A) systems. R-22 pressure switches must not be used as replacements for the Puron (R-410A) air conditioner.

Low Pressure Switch (24 and 30 size only)

This switch is located on the suction line and protects against low suction pressures caused by such events as loss of charge, low airflow across indoor coil, dirty filters, etc. It opens at 50½ psig (957 Pa). If system pressure is above this, switch should be closed.

To check switch:

1. Turn off all power to unit.
2. Disconnect leads on switch.
3. Apply ohmmeter leads across switch. You should have continuity on a closed switch.

NOTE: Because these switches are attached to refrigeration system under pressure, it is not advisable to remove this device for troubleshooting unless you are reasonably certain that a problem exists. If switch must be removed, remove and recover all system charge so that pressure gauges read 0 psi (0 Pa). Never open system without breaking vacuum with dry nitrogen.

High-Pressure Switch

The high-pressure switch is located in the discharge line and protects against excessive condenser coil pressure. It opens at 650 psig (31.1 kPa). High pressure may be caused by a dirty condenser coil, failed fan motor, or condenser air recirculation.

To check switch:

1. Turn off all power to unit.
2. Disconnect leads on switch.
3. Apply ohmmeter leads across switch. You should have continuity on a good switch.

Compressor (Puron (R-410A) Refrigerant)

The compressor used in this product is specifically designed to operate with Puron (R-410A) refrigerant and cannot be interchanged.

The compressor is an electrical (as well as mechanical) device. Exercise extreme caution when working near compressors. Power should be shut off, if possible, for most troubleshooting techniques. Refrigerants present additional safety hazards.

WARNING

FIRE/EXPLOSION HAZARD

Failure to follow this warning could result in personal injury or death and/or property damage.

Wear safety glasses and gloves when handling refrigerants. Keep torches and other ignition sources away from refrigerants and oils.

For models that have a scroll compressor, the compressor pumps refrigerant throughout the system by the interaction of a stationary and an orbiting scroll. The scroll compressor has no dynamic suction or discharge valves, and it is more tolerant of stresses caused by debris, liquid slugging, and flooded starts. The compressor is equipped with a noise reducing shutdown device and an internal pressure relief port. The pressure relief port is a safety device, designed to protect against extreme high pressure. The relief port has an operating range between 550 (26.3 kPa) and 625 (29.9 kPa) psig differential pressure.

Refrigerant

WARNING

EXPLOSION, ENVIRONMENTAL HAZARD

Failure to follow this warning could result in personal injury, death or equipment damage.

This system uses Puron (R-410A) refrigerant which has higher operating pressures than R-22 and other refrigerants. No other refrigerant may be used in this system. Gauge set, hoses, and recovery system must be designed to handle Puron (R-410A). If you are unsure, consult the equipment manufacturer.

This system uses Puron (R-410A) refrigerant which has higher operating pressures than R-22 and other refrigerants. No other refrigerant may be used in this system. Gauge set, hoses, and recovery system must be designed to handle Puron (R-410A). If you are unsure, consult the equipment manufacturer. Failure to use Puron (R-410A) compatible servicing equipment or replacement components may result in property damage or injury.

Compressor Oil

The Copeland scroll compressor uses 3MAF POE oil. If additional oil is needed, use Uniqema RL32-3MAF. If this oil is not available, use Copeland Ultra 32 CC or Mobil Arctic EAL22 CC. This oil is extremely hygroscopic, meaning it absorbs water readily. POE oils can absorb 15 times as much water as other oils designed for HCFC and CFC refrigerants. Take all necessary precautions to avoid exposure of the oil to the atmosphere.

Rotary Compressor

The 24 and 30 size units use a single cylinder rotary compressor. This compressor utilizes a rotor which is positioned eccentrically with respect to the shell. Refrigerant gas is ported directly into the compression chamber and discharged into the surrounding area. It is also known as a "high-side" design since high pressure gas surrounds the motor and compression chamber. The majority of the shell will be hot to the touch. The rotary compressor also utilizes an external built-in accumulator to reduce the likelihood of refrigerant liquid from entering the compressor.

Servicing Systems on Roofs with Synthetic Materials

POE (polyolester) compressor lubricants are known to cause long term damage to some synthetic roofing materials. Exposure, even if immediately cleaned up, may cause embrittlement (leading to cracking) to occur in one year or more. When performing any service that may risk exposure of compressor oil to the roof, take appropriate precautions to protect roofing. Procedures which risk oil leakage include, but are not limited to, compressor replacement, repairing refrigerant leaks, replacing refrigerant components such as filter drier, pressure switch, metering device, coil, accumulator, or reversing valve.

Synthetic Roof Precautionary Procedure

1. Cover extended roof working area with an impermeable polyethylene (plastic) drip cloth or tarp. Cover an approximate 10 x 10 ft (3 x 3 m) area.
2. Cover area in front of the unit service panel with a terry cloth shop towel to absorb lubricant spills, prevent run-offs, and protect drop cloth from tears caused by tools or components.
3. Place terry cloth shop towel inside unit immediately under component(s) to be serviced and prevent lubricant run-offs through the louvered openings in the unit base.
4. Perform required service.
5. Remove and dispose of any oil contaminated material per local codes.

Liquid Line Filter Drier

The filter drier is specifically designed to operate with Puron (R-410A). Use only factory-authorized components. Filter drier must be replaced whenever the refrigerant system is opened. When removing a filter drier, use a tubing cutter to cut the drier from the system. Do not unsweat a filter drier from the system. Heat from unsweating will release moisture and contaminants from drier into system.

Puron (R-410A) Refrigerant Charging

Refer to unit information plate and charging chart. Some R-410A refrigerant cylinders contain a dip tube to allow liquid refrigerant to flow from cylinder in upright position. For cylinders equipped with a dip tube, charge Puron (R-410A) units with cylinder in upright position and a commercial metering device in manifold hose. Charge refrigerant into suction-line.

Troubleshooting

Refer to the Troubleshooting Chart ([Table 12](#)) for troubleshooting information.

Start-up Checklist

Use the Start-Up Checklist at the back of this manual.

My Learning Center is your central location for professional residential HVAC training resources that help strengthen careers and businesses. We believe in providing high quality learning experiences both online and in the classroom.

Access My Learning Center with your HVACpartners credentials at www.MLCTraining.com. Please contact us at mylearning@carrier.com with questions.

Table 12 – Troubleshooting Chart

SYMPTOM	CAUSE	REMEDY
Compressor and outdoor fan will not start	Power failure	Call power company
	Fuse blown or circuit breaker tripped	Replace fuse or reset circuit breaker
	Defective contactor, transformer, control relay, or high-pressure, loss-of-charge or low-pressure switch	Replace component
	Insufficient line voltage	Determine cause and correct
	Incorrect or faulty wiring	Check wiring diagram and rewire correctly
	Thermostat setting too low/too high	Reset thermostat setting
Compressor will not start but condenser fan runs	Faulty wiring or circuit	Check wiring and repair or replace
	Loose connections in compressor	Check wiring and repair or replace
	Compressor motor burned out, seized, or internal overload open	Determine cause Replace compressor
	Defective run capacitor, overload, or PTC (positive temperature coefficient) thermistor	Determine cause and replace
	One leg of 3-phase power dead	Replace fuse or reset circuit breaker Determine cause
Low input voltage	Determine cause and correct	
Three-phase scroll compressor (size 30-60 unit) has a low pressure differential	Scroll compressor is rotating in the wrong direction	Correct the direction of rotation by reversing the 3-phase power leads to the unit
Compressor cycles (other than normally satisfying) cooling/heating calls	Refrigerant overcharge or undercharge	Recover refrigerant, evacuate system, and recharge to capacities shown on rating plate
	Defective compressor	Replace and determine cause
	Insufficient line voltage	Determine cause and correct
	Blocked outdoor coil	Determine cause and correct
	Defective run/start capacitor, overload or start relay	Determine cause and replace
	Faulty outdoor fan motor or capacitor	Replace
	Restriction in refrigerant system	Locate restriction and remove
Compressor operates continuously	Dirty air filter	Replace filter
	Unit undersized for load	Decrease load or increase unit size
	Thermostat temperature set too low	Reset thermostat setting
	Low refrigerant charge	Locate leak, repair, and recharge
	Air in system	Recover refrigerant, evacuate system, and recharge
	Outdoor coil dirty or restricted	Clean coil or remove restriction
Excessive head pressure	Dirty air filter	Replace filter
	Dirty indoor or outdoor coil	Clean coil
	Refrigerant overcharged	Recover excess refrigerant
	Air in system	Recover refrigerant, evacuate system, and recharge
	Indoor or outdoor air restricted or air short-cycling	Determine cause and correct
Head pressure too low	Low refrigerant charge	Check for leaks, repair and recharge
	Restriction in liquid tube	Remove restriction
Excessive suction pressure	Refrigerant overcharged	Recover excess refrigerant
Suction pressure too low	Dirty air filter	Replace filter
	Low refrigerant charge	Check for leaks, repair and recharge
	Metering device or low side restricted	Remove source of restriction
	Insufficient coil airflow	Check filter—replace if necessary
	Temperature too low in conditioned area	Reset thermostat setting
	Outdoor ambient below 55°F (13°C)	Install low-ambient kit
	Filter drier restricted	Replace

Start-Up Checklist

(Remove and Store in Job Files)

I. PRELIMINARY INFORMATION

MODEL NO.: _____

SERIAL NO.: _____

DATE: _____

TECHNICIAN: _____

II. PRESTART-UP (Insert check mark in box as each item is completed)

- () VERIFY THAT ALL PACKING MATERIALS HAVE BEEN REMOVED FROM UNIT
- () REMOVE ALL SHIPPING HOLD DOWN BOLTS AND BRACKETS PER INSTALLATION INSTRUCTIONS
- () CHECK ALL ELECTRICAL CONNECTIONS AND TERMINALS FOR TIGHTNESS
- () CHECK THAT INDOOR (EVAPORATOR) AIR FILTER IS CLEAN AND IN PLACE
- () VERIFY THAT UNIT INSTALLATION IS LEVEL
- () CHECK FAN WHEEL, AND PROPELLER FOR LOCATION IN HOUSING/ORIFICE AND SETSCREW TIGHTNESS

III. START-UP

ELECTRICAL

SUPPLY VOLTAGE _____

COMPRESSOR AMPS _____

INDOOR (EVAPORATOR) FAN AMPS _____

TEMPERATURES

OUTDOOR (CONDENSER) AIR TEMPERATURE _____ DB

RETURN-AIR TEMPERATURE _____ DB _____ WB

COOLING SUPPLY AIR _____ DB _____ WB

PRESSURES

REFRIGERANT SUCTION _____ PSIG, SUCTION LINE TEMP* _____

REFRIGERANT DISCHARGE _____ PSIG, LIQUID TEMP† _____

- () VERIFY REFRIGERANT CHARGE USING CHARGING CHARTS

* Measured at suction inlet to compressor

† Measured at liquid line leaving condenser.

