

50VG-A

Performance™ 15-16 SEER 2-Stage Packaged Air Conditioner System with Puron® (R-410A) Refrigerant Single and Three Phase 2-5 Nominal Tons (Sizes 24-60)



Installation Instructions

IMPORTANT: Effective January 1, 2015, all split system and packaged air conditioners must be installed pursuant to applicable regional efficiency standards issued by the Department of Energy.

NOTE: Read the entire instruction manual before starting the installation.

NOTE: Installer: Make sure the Owner's Manual and Service Instructions are left with the unit after installation.

TABLE OF CONTENTS

	PAGE
SAFETY CONSIDERATIONS	1
INTRODUCTION	2
RECEIVING AND INSTALLATION	2-10
Check Equipment	2
Identify Unit	2
Inspect Shipment	2
Provide Unit Support	2
Roof Curb	2
Slab Mount	2
Provide Clearances	6
Field Fabricate Ductwork	6
Rig and Place Unit	6
Inspection	7
Rigging/Lifting of Unit	7
Connect Condensate Drain	7
Install Duct Connections	7
Configuring Units for Downflow (Vertical) Discharge	8
Install Electrical Connections	9
High-Voltage Connections	9
Special Procedures for 208v Operation	9
Control Voltage Connections	9
Standard Connection	9
Transformer Protection	10
PRE-START-UP	11
START-UP	11-13
Check Cooling and Accessory Electric Heat (if applicable)	11
Operation	11
Check for Refrigerant Leaks	11
Start-Up Adjustments	12
Checking and Adjusting Refrigerant Charge	12
Indoor Airflow and Airflow Adjustments	12
Low Stage Cooling	12
High Stage Cooling	13
High Stage Enhanced Dehumidification Cooling (208/230 Vac Models)	13
Continuous Fan	13
Cooling Sequence of Operation	13
MAINTENANCE	27-29
Air Filter	27
Indoor Blower and Motor	27
Outdoor Coil, Indoor Coil, and Condensate Drain Pan	28
Outdoor Fan	28
Electrical Controls and Wiring	28
Refrigerant Circuit	29

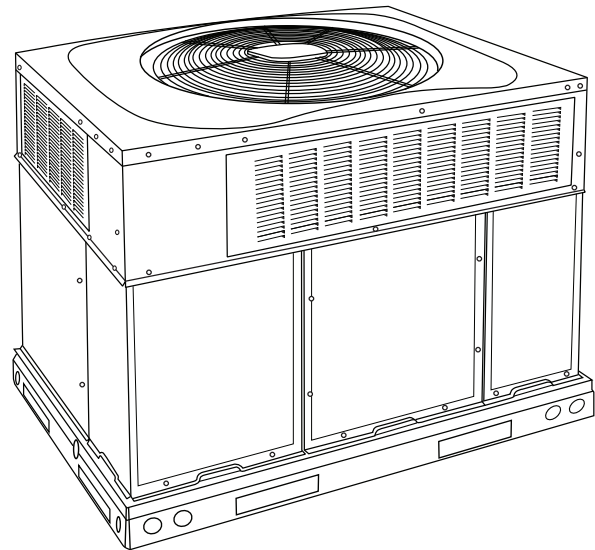

A09033

Fig. 1 - Unit 50VG-A

Evaporator Airflow	29
Puron Items	29
TROUBLESHOOTING	30
START-UP CHECKLIST	30

SAFETY CONSIDERATIONS

Improper installation adjustment, alteration, service, maintenance, or use can cause explosion, fire, electrical shock, or other conditions which may cause death, personal injury, or property damage. Consult a qualified installer, service agency, or your distributor or branch for information or assistance. The qualified installer or agency must use factory-authorized kits or accessories when modifying this product. Refer to the individual instructions packaged with the kits or accessories when installing.

Follow all safety codes. Wear safety glasses, protective clothing, and work gloves. Use quenching cloth for brazing operations. Have a fire extinguisher available. Read these instructions thoroughly and follow all warnings or cautions included in literature and attached to the unit. Consult local building codes, the current editions of the National Electrical Code (NEC) NFPA 70. In Canada refer to the current editions of the Canadian electrical Code CSA C22.1.

Recognize safety information. This is the safety-alert symbol . When you see this symbol on the unit and in instructions or manuals, be alert to the potential for personal injury. Understand these signal words; DANGER, WARNING, and CAUTION. These words are used with the safety-alert symbol. DANGER identifies the most serious hazards which **will** result in severe personal injury or death. WARNING signifies hazards which **could** result in personal injury or death. CAUTION is used to identify unsafe practices which **may** result in minor personal injury or product and property damage. NOTE is used to highlight suggestions which **will** result in enhanced installation, reliability, or operation.

⚠ WARNING

ELECTRICAL SHOCK HAZARD

Failure to follow this warning could result in personal injury or death.

Before installing or servicing system, always turn off main power to system and install lockout tag. There may be more than one disconnect switch. Turn off accessory heater power switch if applicable.

⚠ WARNING

PERSONAL INJURY AND ENVIRONMENTAL HAZARD

Failure to relieve system pressure could result in personal injury and/or death.

1. Relieve pressure and recover all refrigerant before servicing existing equipment, and before final unit disposal. Use all service ports and open all flow-control devices, including solenoid valves.
2. Federal regulations require that you do not vent refrigerant into the atmosphere. Recover during system repair or final unit disposal.

⚠ CAUTION

CUT HAZARD

Failure to follow this caution may result in personal injury.

When removing access panels (see Fig. 17) or performing maintenance functions inside your unit, be aware of sharp sheet metal parts and screws. Although special care is taken to reduce sharp edges to a minimum, be extremely careful and wear appropriate protective clothing, safety glasses and gloves when handling parts or reaching into the unit.

INTRODUCTION

The 50VG-A packaged air conditioner is fully self-contained and designed for outdoor installation (See Fig.1). See Fig. 2 and 3 for unit dimensions. All unit sizes have discharge openings for both horizontal and downflow configurations, and are factory shipped with all downflow duct openings covered. The unit may be installed either on a rooftop or on a ground-level cement slab. (See Fig. 4 for roof curb dimensions.)

RECEIVING AND INSTALLATION

Step 1 — Check Equipment

IDENTIFY UNIT

The unit model number and serial number are printed on the unit informative plate. Check this information against shipping papers.

INSPECT SHIPMENT

Inspect for shipping damage before removing packaging materials. If unit appears to be damaged or is torn loose from its anchorage, have it examined by transportation inspectors before removal. Forward claim papers directly to transportation company. Manufacturer is not responsible for any damage incurred in transit. Check all items against shipping list. Immediately notify the nearest equipment distribution office if any item is missing. To prevent loss or damage, leave all parts in original packages until installation.

If the unit is to be mounted on a curb in a downflow application, review Step 7 to determine which method is to be used to remove the downflow panels before rigging and lifting into place. The panel removal process may require the unit to be on the ground.

Step 2 — Provide Unit Support

IMPORTANT: The unit must be secured to the curb by installing screws through the bottom of the curb flange and into the unit base rails. When installing large base units onto the common curb, the screws must be installed before allowing the full weight of the unit to rest on the curb. A minimum of six screws are required for large base units. Failure to secure unit properly could result in an unstable unit. See Warning near Rigging/Lifting information and accessory curb instructions for more details.

For hurricane tie downs, contact distributor for details and PE (Professional Engineering) Certificate if required.

ROOF CURB

Install accessory roof curb in accordance with instructions shipped with curb (See Fig. 4). Install insulation, cant strips, roofing, and flashing. Ductwork must be attached to curb.

IMPORTANT: The gasketing of the unit to the roof curb is critical for a water tight seal. Install gasketing material supplied with the roof curb. Improperly applied gasketing also can result in air leaks and poor unit performance.

Curb should be level to within 1/4 in. (6.35 mm) (See Fig 6). This is necessary for unit drain to function properly. Refer to accessory roof curb installation instructions for additional information as required.

Installation on older “G” series roof curbs.

Two accessory kits are available to aid in installing a new “G” series unit on an old “G” roof curb.

1. Accessory kit number CPADCURB001A00, (small chassis) and accessory kit number CPADCURB002A00, (large chassis) includes roof curb adapter and gaskets for the perimeter seal and duct openings. No additional modifications to the curb are required when using this kit.
2. An alternative to the adapter curb is to modify the existing curb by removing the outer horizontal flange and use accessory kit number CPGSKTKIT001A00 which includes spacer blocks (for easy alignment to existing curb) and gaskets for the perimeter seal and duct openings. This kit is used when existing curb is modified by removing outer horizontal flange.

⚠ CAUTION

UNIT/STRUCTURAL DAMAGE HAZARD

Failure to follow this caution may result in property damage.

Ensure there is sufficient clearance for saw blade when cutting the outer horizontal flange of the roof curb so there is no damage to the roof or flashing.

SLAB MOUNT

Place the unit on a solid, level pad that is at least 2 in. (51 mm) above grade. The pad should extend approximately 2 in. (51 mm) beyond the casing on all 4 sides of the unit (See Fig. 7). Do not secure the unit to the pad *except* when required by local codes.

UNIT	ELECTRICAL CHARACTERISTICS	UNIT WT.		UNIT HEIGHT IN/MM	CENTER OF GRAVITY IN/MM			
		LB	KG		X	Y	Z	
50VG-A24---(3)0	208/230-1	327	148.3	44-1/8 1121	20-1/2	520.7	15-3/4 400.1	16-5/8 422.3
50VG-A30---(3)50	208/230-1, 208/230-3-60	334	151.5	44-1/8 1121	20-1/2	520.7	15-3/4 400.1	17-3/8 441.3

UNIT	VOLTAGE	CORNER WEIGHT LB/KG		
		"1"	"2"	"3"
50VG-A24---(3)0	208/230	39.2	22.2	52.3
50VG-A30---(3)50	208/230	40.1	22.7	53.4

NOTE: ALL TABLE DATA RELEVANT FOR ALL FACTORY INSTALLED OPTIONS EXCEPT ECONOMIZER

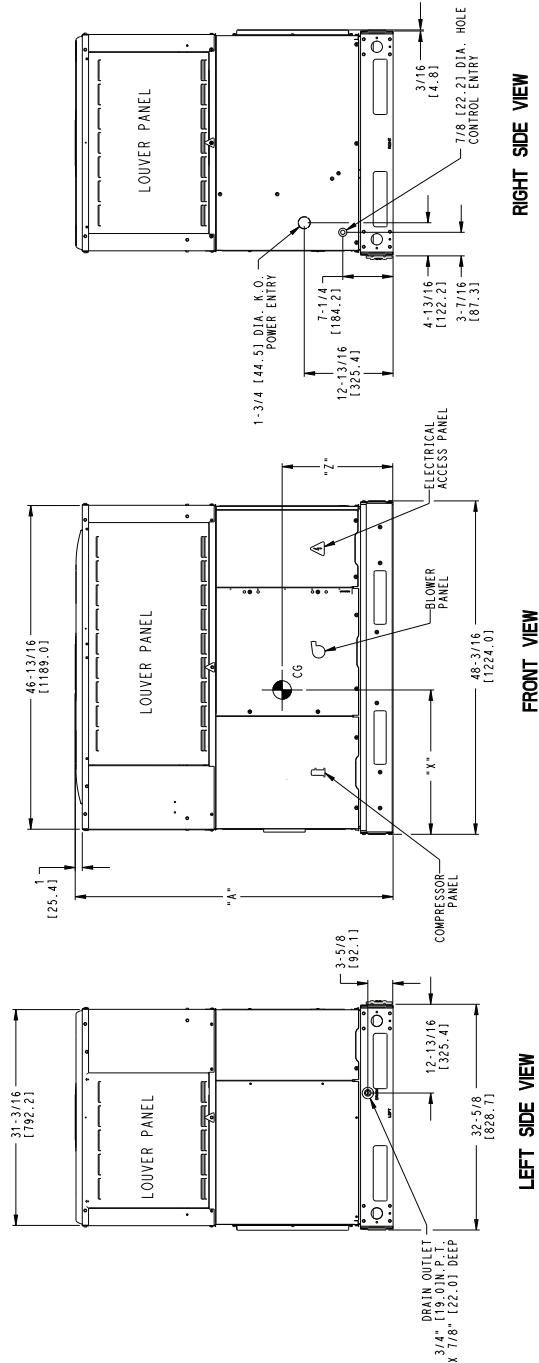
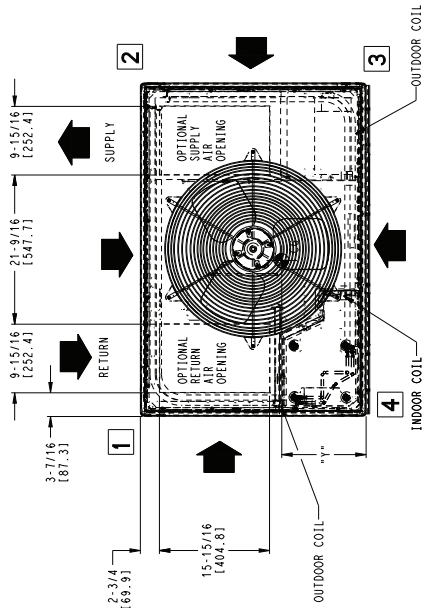

REQUIRED CLEARANCES TO COMBUSTIBLE MATL.

TOP OF UNIT.....14 [355.6]
 DUCT SIDE OF UNIT.....7 [178.0]
 BOTTOM OF UNIT.....6 [152.4]
 ELECTRICAL PANEL.....36 [914.4]

REQ. REQUIRED CLEARANCES:

BETWEEN UNITS, POWER ENTRY SIDE.....42 [1066.8]
 UNIT AND UNGROUNDED SURFACES, POWER ENTRY SIDE.....36 [914.0]
 UNIT AND BLOCK OR CONCRETE WALLS AND OTHER GROUNDED SURFACES, POWER ENTRY SIDE.....42 [1066.8]

REQUIRED CLEARANCE FOR OPERATION AND SERVICING

EVAP. COIL ACCESS SIDE.....36 [914.0]
 POWER ENTRY SIDE.....42 [1066.8]
 LEAVE FOR REC. REQUIREMENTS).....48 [1219.2]
 SIDE OPPOSITE DUCTS.....36 [914.0]
 DUCT PANEL.....12 [304.8]

*MINIMUM DISTANCES: IF UNIT IS PLACED LESS THAN 12 [304.8] FROM WALL SYSTEM, THEN SYSTEM PERFORMANCE MAY BE COMPROMISED.

DIMENSIONS IN [] ARE IN MILLIMETERS

REAR VIEW

RIGHT SIDE VIEW

FRONT VIEW

LEFT SIDE VIEW

REV	A
50VG500074	

50VG--A

Fig. 2 - 50VG-A24-30 Unit Dimensions

50VG--A

UNIT	ELECTRICAL CHARACTERISTICS	UNIT HT. IN/MM				CENTER OF GRAVITY IN/MM					
		LB	KG	"A"	X	Y	Z				
50VG-A36---(3/5/6)0	208/230-1, 208/230-3-60, 460-3	389	176.4	44-3/4	1137	20-1/4	514.4	17-1/2	444.5	17-5/8	447.7
50VG-A42---(3/5/6)0	208/230-1, 208/230-3-60, 460-3	392	177.8	44-3/4	1137	20-1/4	514.4	17-1/2	444.5	17-5/8	447.7
50VG-A48---(3/5/6)0	208/230-1, 208/230-3-60, 460-3	444	201.4	50-3/4	1289	20-1/4	514.4	17-1/2	444.5	17-5/8	447.7
50VG-A60---(3/5/6)0	208/230-1, 208/230-3-60, 460-3	484	210.5	52-3/4	1340	20-1/4	514.4	17-1/2	444.5	18	457.2

UNIT	VOLTAGE	CORNER WEIGHTS LB/KG							
		"1"	"2"	"3"	"4"				
50VG-A36---(3/5/6)0	208/230/460	46.7	26.5	62.2	35.3	93.4	52.9	155.6	61.8
50VG-A42---(3/5/6)0	208/230/460	47.0	26.7	62.7	35.6	94.1	53.3	156.8	62.2
50VG-A48---(3/5/6)0	208/230/460	53.3	30.2	71.0	40.3	106.6	60.4	177.6	70.5
50VG-A60---(3/5/6)0	208/230/460	55.7	31.6	74.2	42.1	111.4	63.1	185.6	73.7

NOTE: ALL TABLE DATA RELEVANT FOR ALL FACTORY INSTALLED OPTIONS EXCEPT ECONOMIZER

REQUIRED CLEARANCES TO COMBUSTIBLE MATL.

	INCHES [MM]
TOP OF UNIT.....	14 [355.6]
DUCT SIDE OF UNIT.....	2 [50.8]
SIDE OPPOSITE DUCTS.....	14 [355.6]
BOTTOM OF UNIT.....	0 [0.0]
ELECTRICAL PANEL.....	36 [914.4]

NEC. REQUIRED CLEARANCES.

	INCHES [MM]
BETWEEN UNITS, POWER ENTRY SIDE.....	42 [1066.8]
UNIT AND UNGROUNDED SURFACES, POWER ENTRY SIDE.....	36 [914.0]
UNIT AND BLOCK OR CONCRETE WALLS AND OTHER GROUNDED SURFACES, POWER ENTRY SIDE.....	42 [1066.8]

REQUIRED CLEARANCE FOR OPERATION AND SERVICING

	INCHES [MM]
EVAP. COIL ACCESS SIDE.....	36 [914.0]
POWER ENTRY SIDE.....	42 [1066.8]
(EXCEPT FOR NEC REQUIREMENTS)	
UNIT TOP.....	48 [1219.2]
SIDE OPPOSITE DUCTS.....	36 [914.0]
DUCT PANEL.....	12 [304.8]

*MINIMUM DISTANCES-IF UNIT IS PLACED LESS THAN 12 [304.8] FROM WALL SYSTEM, THEN SYSTEM PERFORMANCE MAYBE COMPROMISED. DIMENSIONS IN () ARE IN MM

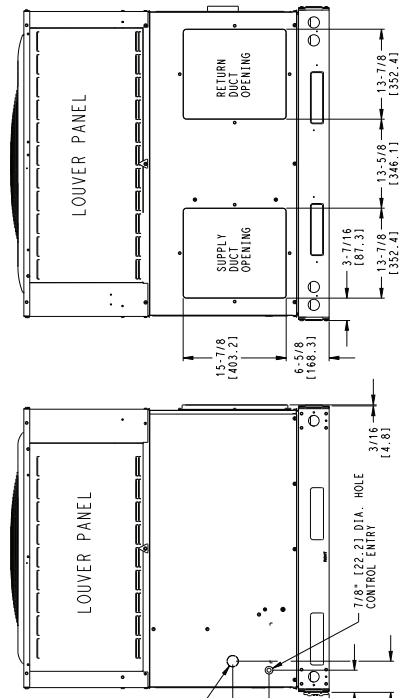
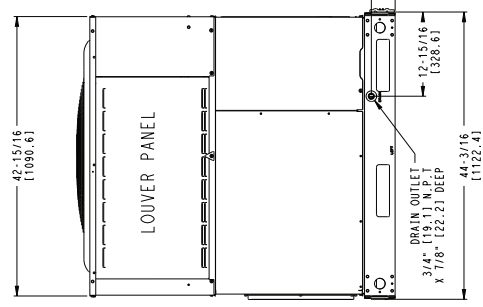
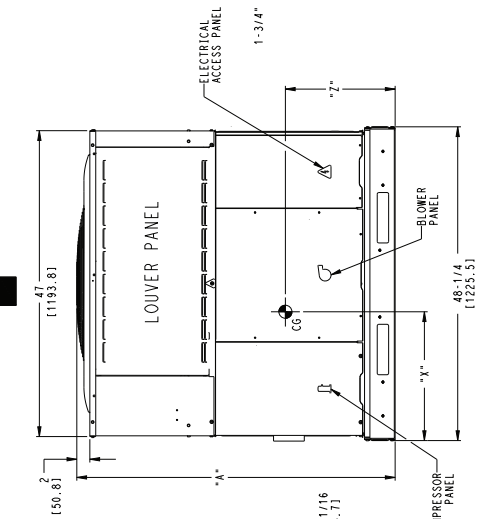
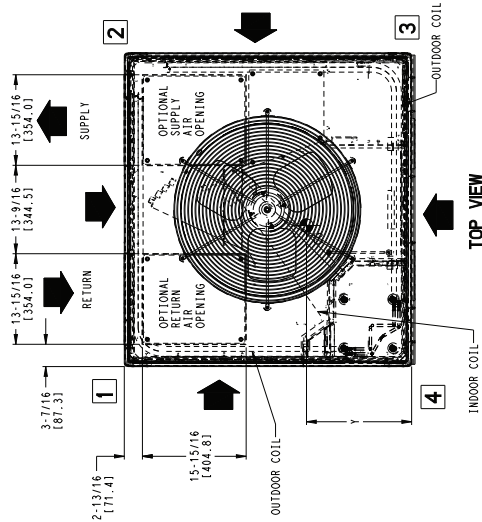

REAR VIEW
50VG500075
REV A

Fig. 3 - 50VG-A36-60 Unit Dimensions

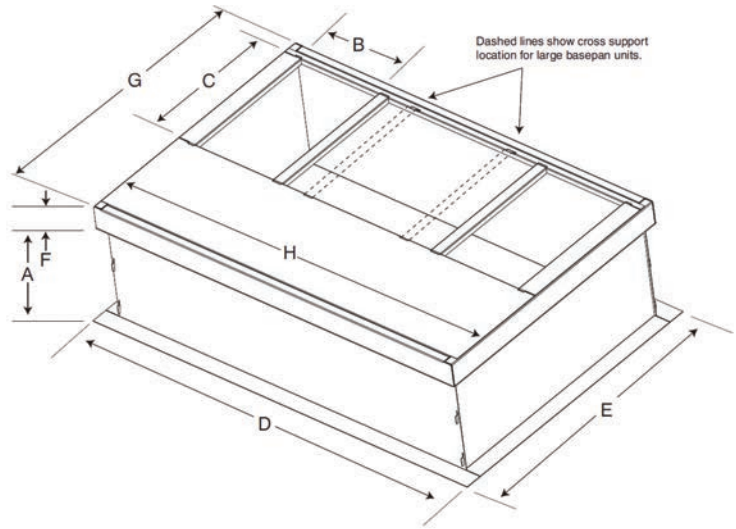
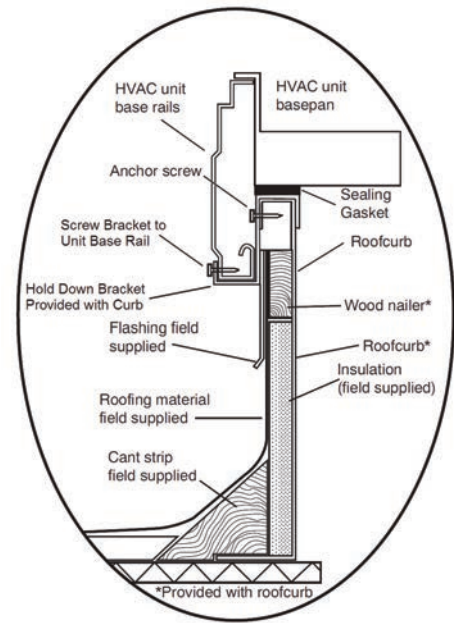

SMALL/COMMON CURB

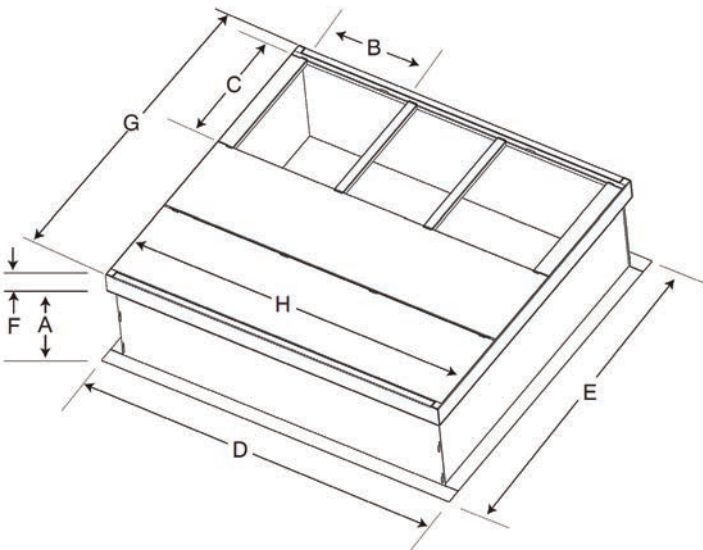

LARGE CURB

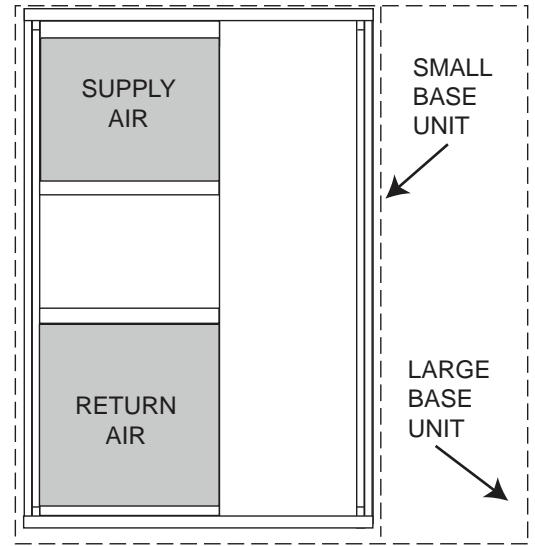

UNIT PLACEMENT ON COMMON CURB

SMALL OR LARGE BASE UNIT

A180216

UNIT SIZE	CATALOG NUMBER	A IN. (mm)	B (small/common base) IN. (mm)*	B (large base) IN. (mm)*	C IN. (mm)	D IN. (mm)	E IN. (mm)	F IN. (mm)	G IN. (mm)	H IN. (mm)
Small or Large	CPRFCURB011B00	14 (356)	10 (254)	14 (356)	16 (406)	47.8 (1214)	32.4 (822)	2.7 (69)	30.6 (778)	46.1 (1170)
Large	CPRFCURB013B00	14 (356)	14 (356)				43.9 (1116)		42.2 (1072)	

* Part Numbers CPRFCURB011B00 can be used on both small and large basepan units. The cross supports must be located based on whether the unit is a small basepan or a large basepan.

NOTES:

1. Roof curb must be set up for unit being installed.
2. Seal strip must be applied, as required, to unit being installed.
3. Roof curb is made of 16-gauge steel.
4. Attach ductwork to curb (flanges of duct rest on curb).
5. Insulated panels: 1-in. (25.4 mm) thick fiberglass 1 lb. density.

Fig. 4 - Roof Curb Dimensions

⚠ CAUTION - NOTICE TO RIGGERS ⚠ PRUDENCE - AVIS AUX MANIPULATEUR

ACCESS PANELS MUST BE IN PLACE WHEN RIGGING.
PANNEAUX D'ACCES DOIT ÊTRE EN PLACE POUR MANIPULATION.

Use top skid as spreader bar. / Utiliser la palette du haut comme barre de répartition

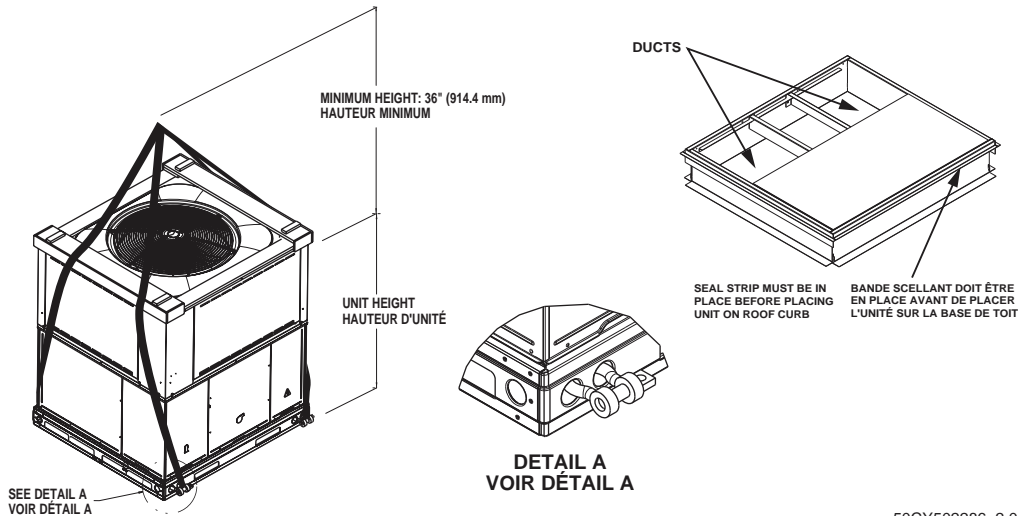

50CY502286 2.0

A09051

Standard Copper Tube Aluminum Fin

Unit*	SMALL CABINET				Unit*	LARGE CABINET							
	24		30			36		42		48		60	
	lb	kg	lb	kg		lb	kg	lb	kg	lb	kg	lb	kg
Rigging Weight	335	152.0	342	155.1	Rigging Weight	397	180.1	400	181.4	452	205.0	472	214.1

NOTE: See dimensional drawing for corner weighs.

Optional Copper Tube Copper Fin

Unit*	SMALL CABINET				Unit*	LARGE CABINET							
	24		30			36		42		48		60	
	lb	kg	lb	kg		lb	kg	lb	kg	lb	kg	lb	kg
Rigging Weight	373	169.2	399	181.0	Rigging Weight	459	208.2	462	210.0	536	243.1	562	255.0

NOTE: See dimensional drawing for corner weighs.

Fig. 5 - 50VG-A Unit Suggested Rigging

Step 3 — Provide Clearances

The required minimum service clearances are shown in Fig. 2 and 3. Adequate ventilation and outdoor air must be provided. The outdoor fan draws air through the outdoor coil and discharges it through the top fan grille. Be sure that the fan discharge does not recirculate to the outdoor coil. Do not locate the unit in either a corner or under an overhead obstruction. The minimum clearance under a partial overhang (such as a normal house overhang) is 48 in. (1219 mm) above the unit top. The maximum horizontal extension of a partial overhang must not exceed 48 in. (1219 mm) **IMPORTANT:** Do not restrict outdoor airflow. An air restriction at either the outdoor-air inlet or the fan discharge may be detrimental to compressor life.

Do not place the unit where water, ice, or snow from an overhang or roof will damage or flood the unit. Do not install the unit on carpeting or other combustible materials. Slab-mounted units should be at least 2 in. (51 mm) above the highest expected water and runoff levels. Do not use unit if it has been under water.

Step 4 — Field-Fabricate Ductwork

Secure all ducts to roof curb and building structure on vertical discharge units. Do not connect ductwork to unit. For horizontal applications, unit is provided with flanges on the horizontal openings. All ductwork should be secured to the flanges. Insulate

and weatherproof all external ductwork, joints, and roof openings with counter flashing and mastic in accordance with applicable codes.

Ducts passing through an unconditioned space must be insulated and covered with a vapor barrier. If a plenum return is used on a vertical unit, the return should be ducted through the roof deck to comply with applicable fire codes. See unit rating plate for any required clearances around ductwork. Cabinet return-air static shall not exceed -.25 IN. W.C.

Step 5 — Rig and Place Unit

Rigging and handling of this equipment can be hazardous for many reasons due to the installation location (roofs, elevated structures, etc.).

Only trained, qualified crane operators and ground support staff should handle and install this equipment.

When working with this equipment, observe precautions in the literature, on tags, stickers, and labels attached to the equipment, and any other safety precautions that might apply.

Training for operators of the lifting equipment should include, but not be limited to, the following:

1. Application of the lifter to the load, and adjustment of the lifts to adapt to various sizes or kinds of loads.
2. Instruction in any special operation or precaution.

50VG--A

3. Condition of the load as it relates to operation of the lifting kit, such as balance, temperature, etc.

Follow all applicable safety codes. Wear safety shoes and work gloves.

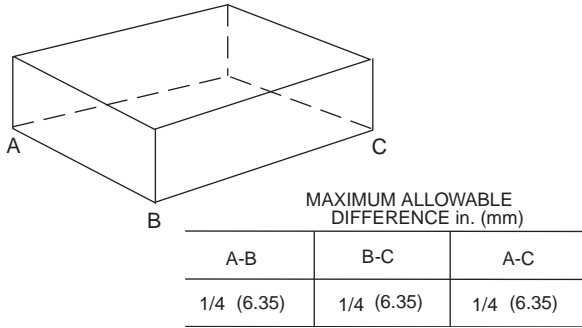

Fig. 6 - Unit Leveling Tolerances

A07925

INSPECTION

Prior to initial use, and at monthly intervals, all rigging shackles, clevis pins, and straps should be visually inspected for any damage, evidence of wear, structural deformation, or cracks. Particular attention should be paid to excessive wear at hoist hooking points and load support areas. Materials showing any kind of wear in these areas must not be used and should be discarded.

⚠ WARNING

UNIT FALLING HAZARD

Failure to follow this warning could result in personal injury or death.

Never stand beneath rigged units or lift over people.

1. Leave top shipping skid on the unit for use as a spreader bar to prevent the rigging straps from damaging the unit. If the skid is not available, use a spreader bar of sufficient length to protect the unit from damage.

⚠ WARNING

PROPERTY DAMAGE HAZARD

Failure to follow this warning could result in personal injury.

When straps are taut, the clevis should be a minimum of 36 in. (914 mm) above the unit top cover.

Rigging/Lifting of Unit (See Fig. 5)

⚠ WARNING

UNIT FALLING HAZARD

Failure to follow this warning could result in personal injury or death.

Large base units must be secured to common curb before allowing full weight of unit to rest on curb. Install screws through curb into unit base rails while rigging crane is still supporting unit.

Lifting holes are provided in base rails as shown.

1. Attach shackles, clevis pins, and straps to the base rails of the unit. Be sure materials are rated to hold the weight of the unit (See Fig. 5).
2. Attach a clevis of sufficient strength in the middle of the straps. Adjust the clevis location to ensure unit is lifted level with the ground.

After the unit is placed on the roof curb or mounting pad, remove the top skid.

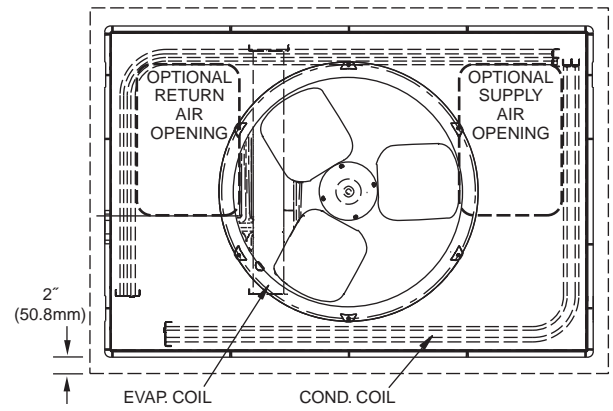

A07926

Fig. 7 - Slab Mounting Detail

Step 6 — Connect Condensate Drain

NOTE: When installing condensate drain connection be sure to comply with local codes and restrictions.

Model 50VG-A disposes of condensate water through a 3/4 in. NPT fitting which exits through the base on the evaporator coil access side. See Fig. 2 and 3 for location.

Condensate water can be drained directly onto the roof in rooftop installations (where permitted) or onto a gravel apron in ground level installations. Install a field-supplied 2-in. (51 mm) condensate trap at end of condensate connection to ensure proper drainage. Make sure that the outlet of the trap is at least 1 in. (25 mm) lower than the drain pan condensate connection to prevent the pan from overflowing (See Fig. 8). When using a gravel apron, make sure it slopes away from the unit.

Connect a drain tube using a minimum of 3/4 in. PVC or 3/4 in. copper pipe (all field-supplied) at the outlet end of the 2-in. (51 mm) trap. Do not undersize the tube. Pitch the drain tube downward at a slope of at least 1-in. (25 mm) for every 10 ft (3.1 m) of horizontal run. Be sure to check the drain tube for leaks. Prime trap at the beginning of the cooling season start-up.

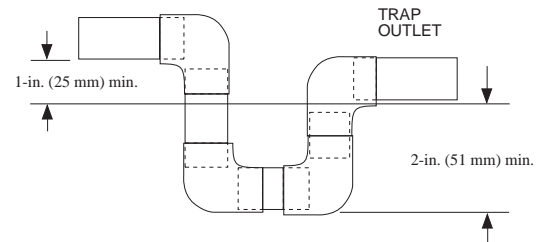

A09052

Fig. 8 - Condensate Trap

Step 7 — Install Duct Connections

The design and installation of the duct system must be in accordance with the standards of the NFPA for installation of non-residence type air conditioning and ventilating systems, NFPA 90A or residence type, NFPA 90B and/or local codes and ordinances.

Select and size ductwork, supply-air registers, and return air grilles according to ASHRAE (American Society of Heating, Refrigeration, and Air Conditioning Engineers) recommendations. The unit has duct flanges on the supply- and return-air openings on the side of the unit.

When designing and installing ductwork, consider the following:

1. All units should have field-supplied filters or accessory filter rack installed in the return-air side of the unit. Recommended sizes for filters are shown in Table 1.
2. Avoid abrupt duct size increases and reductions. Abrupt change in duct size adversely affects air performance.

IMPORTANT: Use flexible connectors between ductwork and unit to prevent transmission of vibration. Use suitable gaskets to

50VG-A

ensure weather-tight and airtight seal. When electric heat is installed, use fireproof canvas (or similar heat resistant material) connector between ductwork and unit discharge connection. If flexible duct is used, insert a sheet metal sleeve inside duct. Heat resistant duct connector (or sheet metal sleeve) must extend 24-in. (610 mm) from electric heater element.

- 3. Size ductwork for cooling air quantity (cfm). The minimum air quantity for proper electric heater operation is listed in Table 2. Heater limit switches may trip at air quantities below those recommended.
- 4. Seal, insulate, and weatherproof all external ductwork. Seal, insulate and cover with a vapor barrier all ductwork passing through conditioned spaces. Follow latest Sheet Metal and Air Conditioning Contractors National Association (SMACNA) and Air Conditioning Contractors Association (ACCA) minimum installation standards for residential heating and air conditioning systems.
- 5. Secure all ducts to building structure. Flash, weatherproof, and vibration-isolate duct openings in wall or roof according to good construction practices.

CONFIGURING UNITS FOR DOWNFLOW (VERTICAL) DISCHARGE

⚠ WARNING

ELECTRICAL SHOCK HAZARD

Failure to follow this warning could result in personal injury or death.

Before performing service or maintenance operations on the system, turn off main power to unit and install lockout tag. There may be more than one disconnect switch.

- 1. Open all electrical disconnects and install lockout tag before starting any service work.
- 2. Remove horizontal (metal) ductcovers to access vertical (downflow) discharge duct knockouts in unit basepan. (See Fig. 9.)

To remove downflow return and supply knockout covers, break front and right side connecting tabs with a screwdriver and hammer. Push cover down to break rear and left side tabs.

NOTE: These panels are held in place with tabs similar to an electrical knockout. Reinstall horizontal duct covers (Fig. 9) shipped on unit from factory. Insure openings are air and watertight.

NOTE: The design and installation of the duct system must be in accordance with the standards of the NFPA for installation of nonresidence-type air conditioning and ventilating systems, NFPA 90A or residence-type, NFPA 90B; and/or local codes and ordinances.

Adhere to the following criteria when selecting, sizing, and installing the duct system:

- 1. Units are shipped for side shot installation.
- 2. Select and size ductwork, supply-air registers, and return-air grilles according to American Society of Heating, Refrigeration and Air Conditioning Engineers (ASHRAE) recommendations.
- 3. Use flexible transition between rigid ductwork and unit to prevent transmission of vibration. The transition may be screwed or bolted to duct flanges. Use suitable gaskets to ensure weather-tight and airtight seal.
- 4. All units must have field-supplied filters or accessory filter rack installed in the return-air side of the unit. Recommended sizes for filters are shown in Table 1.
- 5. Size all ductwork for maximum required airflow (either heating or cooling) for unit being installed. Avoid abrupt

duct size increases or decreases or performance may be affected.

- 6. Adequately insulate and weatherproof all ductwork located outdoors. Insulate ducts passing through unconditioned space, and use vapor barrier in accordance with latest issue of Sheet Metal and Air Conditioning Contractors National Association (SMACNA) and Air Conditioning Contractors of America (ACCA) minimum installation standards for heating and air conditioning systems. Secure all ducts to building structure.
- 7. Flash, weatherproof, and vibration-isolate all openings in building structure in accordance with local codes and good building practices.

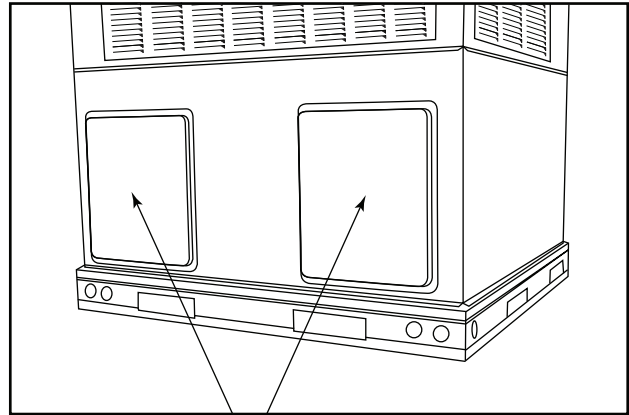

Horizontal Duct Covers

A09076

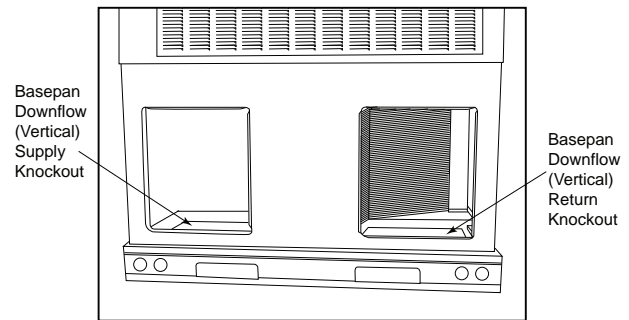

A09093

Fig. 9 - Supply and Return Duct Opening

Step 8 — Install Electrical Connections

⚠ WARNING

ELECTRICAL SHOCK HAZARD

Failure to follow this warning could result in personal injury or death.

The unit cabinet must have an uninterrupted, unbroken electrical ground to minimize the possibility of personal injury if an electrical fault should occur. This ground may consist of an electrical wire connected to the unit ground screw in the control compartment, or conduit approved for electrical ground when installed in accordance with NFPA 70 (NEC) (latest edition) (in Canada, Canadian Electrical Code CSA C22.1) and local electrical codes.

⚠ CAUTION

UNIT COMPONENT DAMAGE HAZARD

Failure to follow this caution may result in damage to the unit being installed.

1. Make all electrical connections in accordance with NFPA 70 (NEC) (latest edition) and local electrical codes governing such wiring. In Canada, all electrical connections must be in accordance with CSA standard C22.1 Canadian Electrical Code Part 1 and applicable local codes. Refer to unit wiring diagram.
2. Use only copper conductor for connections between field-supplied electrical disconnect switch and unit. **DO NOT USE ALUMINUM WIRE.**
3. Be sure that high-voltage power to unit is within operating voltage range indicated on unit rating plate. On 3-phase units, ensure phases are balanced within 2 percent. Consult local power company for correction of improper voltage and/or phase imbalance.
4. Do not damage internal components when drilling through any panel to mount electrical hardware, conduit, etc.

HIGH-VOLTAGE CONNECTIONS

The unit must have a separate electrical service with a field-supplied, waterproof disconnect switch mounted at, or within sight from the unit. Refer to the unit rating plate, NEC and local codes for maximum fuse/circuit breaker size and minimum circuit amps (ampacity) for wire sizing.

The field-supplied disconnect may be mounted on the unit over the high-voltage inlet hole when the standard power and low-voltage entry points are used. See Fig. 2 and 3 for acceptable location.

See unit wiring label (Fig. 12, 13 and 14) and Fig. 10 for reference when making high voltage connections. Proceed as follows to complete the high-voltage connections to the unit.

Single phase units:

1. Run the high-voltage (L1, L2) and ground lead into the control box.
2. Connect ground lead to chassis ground connection.
3. Locate the black and yellow wires connected to the line side of the contactor.
4. Connect field L1 to black wire from connection 11 of the compressor contactor.

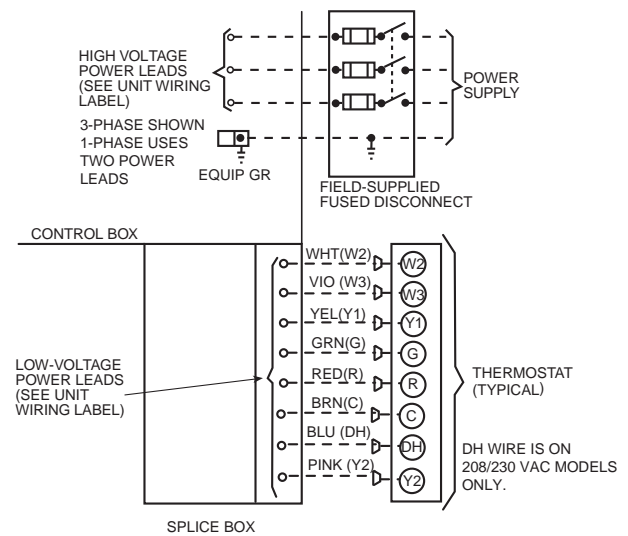

Fig. 10 - High- and Control-Voltage Connections

A12565

5. Connect field wire L2 to yellow wire from connection 23 of the compressor contactor.

Three-phase units:

1. Run the high-voltage (L1, L2, L3) and ground lead into the control box.
2. Connect ground lead to chassis ground connection.
3. Locate the black and yellow wires connected to the line side of the contactor.
4. Connect field L1 to black wire from connection 11 of the compressor contactor.
5. Connect field wire L3 to yellow wire from connection 13 of the compressor contactor.
6. Connect field wire L2 to blue wire from compressor.

SPECIAL PROCEDURES FOR 208-V OPERATION

⚠ WARNING

ELECTRICAL SHOCK HAZARD

Failure to follow this warning could result in personal injury or death.

Before installing or servicing system, always turn off main power to system and install lockout tag. With disconnect switch open, move black wire from transformer (3/16 in.) (4.8 mm) terminal marked 230 to terminal marked 208. This retaps transformer to primary voltage of 208 vac.

CONTROL VOLTAGE CONNECTIONS

NOTE: Do not use any type of power-stealing thermostat. Unit control problems may result.

Use no. 18 American Wire Gage (AWG) color-coded, insulated (35°C minimum) wires to make the control voltage connections between the thermostat and the unit. If the thermostat is located more than 100 ft (30.5 m) from the unit (as measured along the control voltage wires), use no. 16 AWG color-coded, insulated (35° C minimum) wires.

STANDARD CONNECTION

Locate the eight low voltage thermostat leads (seven for 460 VAC models) in 24 volt splice box. See Fig. 10 for connection diagram. Run the low-voltage leads from the thermostat, through the control wiring inlet hole grommet (Fig. 2 and 3), and into the low-voltage splice box. Provide a drip loop before running wires through panel. Secure and strain relief all wires so that they do not interfere with operation of unit.

If an accessory electric heater is installed, low voltage leads from heater must be connected to factory supplied control leads from Indoor Fan Board P4 connector.

IMPORTANT: Dehumidification control must open control circuit on humidity rise above set point.

Use of the dehumidification cooling fan speed requires use of either a 24 VAC dehumidistat or a thermostat which includes control of a 24 VAC dehumidistat connection. In either case, the dehumidification control must open the control circuit on humidity rise above the dehumidification set point.

NOTE: If the unit 24V wires do not have a matching receptacle, cut the 24V wires from the electric heater plug, strip the ends, and wire nut together to match the schematic connections. If the electric heater 24V wires do not have a matching plug, cut the 24V wires

from the unit receptacle, strip the ends, and wire nut together to match the schematic connections.

Factory wires are provided for electric heat staging W1 and W2 (W2 and W3 on IFB). If room thermostat has only one stage of supplemental heat, connect white and violet wires shown in Fig. 10 to second stage heat field wire.

Some electric heaters have four control wires (plus common wire). Consult unit wiring diagram and electric heater wiring diagram for additional details.

TRANSFORMER PROTECTION

The transformer is of the energy-limiting type, however a direct short will likely blow a secondary fuse. If an overload or short is present, correct overload condition and check for blower fuse on Indoor Fan Board. Replace fuse as required with correct size and rating.

50VG--A

Table 1 – Physical Data-Unit 50VG-A

UNIT SIZE	24	30	36	42	48	60
NOMINAL CAPACITY (ton)	2	2-1/2	3	3-1/2	4	5
SHIPPING WEIGHT lb.	335	342	397	400	452	472
SHIPPING WEIGHT (kg)	152.0	155.1	180.1	181.4	205.0	214.1
COMPRESSORS	Scroll					
Quantity	1					
REFRIGERANT (R-410A)						
Quantity lb	6.4	8.3	8.1	8.7	10.8	12.1
Quantity (kg)	2.9	3.8	3.7	3.9	4.9	5.5
REFRIGERANT METERING DEVICE	TXV					
OUTDOOR COIL						
Rows...Fins/in.	1...21	2...21	2...21	2...21	2...21	2...21
Face Area (sq ft)	13.6	13.6	13.6	13.6	19.4	21.4
OUTDOOR FAN						
Nominal Cfm	2500	2700	3000	3000	3300	3600
Diameter in.	24	24	26	26	26	26
Diameter (mm)	609.6	609.6	660.4	660.4	660.4	660.4
Motor Hp (Rpm)	1/10 (810)	1/5 (810)	1/5 (810)	1/5 (810)	1/5 (810)	1/5 (810)
INDOOR COIL						
Rows...Fins/in.	3...17	3...17	3...17	3...17	3...17	3...17
Face Area (sq ft)	3.7	3.7	4.7	4.7	5.7	5.7
INDOOR BLOWER						
Nominal Low Stage Cooling Airflow (Cfm)	600	750	900	1050	1200	1200
Nominal High Stage Cooling Airflow (Cfm)	800	1000	1200	1400	1600	1750
Size in.	10x10	10x10	11x10	11x10	11x10	11x10
Size (mm.)	254x254	254x254	279.4x254	279.4x254	279.4x254	279.4x254
Motor HP (RPM)	1/2 (1050)	1/2 (1050)	3/4 (1000)	3/4 (1075)	1.0 (1075)	1.0 (1075)
HIGH-PRESSURE SWITCH (psig) Cut-out Reset (Auto)	650 +/- 15 420 +/- 25					
LOW-PRESSURE SWITCH (psig) cut-out Reset (auto)	50 +/- 7 95 +/- 7					
RETURN-AIR FILTERS†‡						
Throwaway Size in.	20x20x1	20x24x1	24x30x1	24x36x1		
Throwaway Size (mm)	508x508x25	508x610x25	610x762x25	610x914x25		

† Required filter sizes shown are based on the larger of the AHRI (Air Conditioning Heating and Refrigeration Institute) rated cooling airflow or the heating airflow velocity of 300 ft/minute for throwaway type or 450 ft/minute for high-capacity type. Air filter pressure drop for non-standard filters must not exceed 0.08 in. W.C.

‡ If using accessory filter rack refer to the filter rack installation instructions for correct filter sizes and quantity.

Table 2 – Minimum Airflow for Safe Electric Heater Operation (CFM)

SIZE	24	30	36	42	48	60
Cfm	800	1000	1200	1400	1600	1750

PRE-START-UP

WARNING

ENVIRONMENTAL, FIRE, EXPLOSION, ELECTRICAL SHOCK HAZARD

Failure to follow this warning could result in personal injury or death and/or property damage.

1. Follow recognized safety practices and wear protective goggles when checking or servicing refrigerant system.
2. Relieve and recover all refrigerant from system before touching or disturbing compressor plug if refrigerant leak is suspected around compressor terminals.
3. Never attempt to repair soldered connection while refrigerant system is under pressure.
4. Do not use torch to remove any component. System contains oil and refrigerant under pressure.
5. To remove a component, wear protective goggles and proceed as follows:
 - a. Shut off electrical power to unit and install lockout tag.
 - b. Relieve and reclaim all refrigerant from system using both high- and low-pressure ports.
 - c. Cut component connecting tubing with tubing cutter and remove component from unit.
 - d. Carefully unsweat remaining tubing stubs when necessary. Oil can ignite when exposed to torch flame.

Use the Start-Up Checklist supplied at the end of this book and proceed as follows to inspect and prepare the unit for initial start-up:

1. Remove all access panels (see Fig. 17).
2. Read and follow instructions on all DANGER, WARNING, CAUTION, and INFORMATION labels attached to, or shipped with unit.
3. Make the following inspections:
 - a. Inspect for shipping and handling damages, such as broken lines, loose parts, disconnected wires, etc.
 - b. Inspect for oil at all refrigerant tubing connections and on unit base. Detecting oil generally indicates a refrigerant leak. Leak test all refrigerant tubing connections using electronic leak detector, or liquid-soap solution. If a refrigerant leak is detected, see following **Check for Refrigerant Leaks** section.
 - c. Inspect all field- and factory-wiring connections. Be sure that connections are completed and tight. Ensure wires do not touch refrigerant tubing or sharp sheet metal edges.
 - d. Inspect coil fins. If damaged during shipping and handling, carefully straighten fins with a fin comb.
4. Verify the following conditions:
 - a. Make sure that outdoor-fan blade is correctly positioned in fan orifice.
 - b. Make sure that air filter(s) is in place.
 - c. Make sure that condensate drain pan and trap are filled with water to ensure proper drainage.
 - d. Make sure that all tools and miscellaneous loose parts have been removed
5. Each unit system has two (2) Schrader-type ports, one low-side Schrader fitting located on the suction line, and one high-side Schrader fitting located on the compressor discharge line. Be sure that caps on the ports are tight.

START-UP

Step 1 — Check Cooling and Accessory Electric Heat (if applicable) Operation

Start and check the unit for proper control operation as follows:

1. Place room thermostat SYSTEM switch or MODE control in OFF position. Observe that blower motor starts when FAN mode is placed in FAN ON position and shuts down when FAN MODE switch is placed in AUTO position.
2. Thermostat:

On a typical two stage thermostat, when the room temperature rises 1 or 2 degrees above the cooling control setting of the thermostat, the thermostat completes the circuit between thermostat terminal R and terminals Y1, and G. These completed circuits through the thermostat connect the contactor coil (C) (through unit wire Y1) and indoor fan board (through unit wire G) across the 24-v. secondary of transformer (TRAN).

On a typical two stage thermostat, when the room temperature is several degrees above the cooling control setting of the thermostat, the thermostat completes the circuit between terminal R and terminals Y1, Y2, and G.
3. If your unit contains accessory electric heat, place system switch or MODE control in HEAT position. Set control above room temperature. Observe that the indoor blower is operating and warm air is flowing through the supply air vents inside your home. Observe that the heating cycle shuts down when the control setting is satisfied. If your unit does not contain accessory electric heat and you would like to obtain it, please contact your local dealer for more information.
4. When using an automatic changeover room thermostat place both SYSTEM or MODE control and FAN mode switches in AUTO positions. Observe that unit operates in Cooling mode when temperature control is set to “call for Cooling” (below room temperature).

NOTE: Once the compressor has started and then has stopped, it should not be started again until 5 minutes have elapsed.

Step 2 — Check for Refrigerant Leaks

WARNING



EXPLOSION HAZARD

Failure to follow this warning could result in death, serious personal injury, and/or property damage.

Never use air or gases containing oxygen for leak testing or operating refrigerant compressors. Pressurized mixtures of air or gases containing oxygen can lead to an explosion.

Proceed as follows to locate and repair a refrigerant leak and to charge the unit:

1. Locate leak and make sure that refrigerant system pressure has been relieved and reclaimed from both high- and low-pressure ports.
 2. Repair leak following Refrigerant Service procedures.
- NOTE:** Install a filter drier whenever the system has been opened for repair.
3. Add a small charge of R-410A refrigerant vapor to system and leak-test unit.
 4. Recover refrigerant from refrigerant system and evacuate to 500 microns if no additional leaks are found.
 5. Charge unit with R-410A refrigerant, using an electronic scale. Refer to unit rating plate for required charge.

Step 3 — Start-Up Adjustments

Complete the required procedures given in the Pre-Start-Up section before starting the unit. Do not jumper any safety devices when operating the unit. Do not operate the unit in cooling mode when the outdoor temperature is below 40°F (4°C) (unless accessory low-ambient kit is installed).

Checking and Adjusting Refrigerant Charge

The refrigerant system is fully charged with R-410A refrigerant and is tested and factory sealed.

NOTE: Adjustment of the refrigerant charge is not required unless the unit is suspected of not having the proper R-410A charge.

A subcooling charging chart is attached to the inside of the compressor access panel. The chart includes the required liquid line temperature at given discharge line pressures and outdoor ambient temperatures.

An accurate thermocouple- or thermistor-type thermometer, and a gauge manifold are required when using the subcooling charging method for evaluating the unit charge. Do not use mercury or small dial-type thermometers because they are not adequate for this type of measurement.

NOTE: Allow system to operate on high stage cooling for a minimum of 15 minutes before checking or adjusting refrigerant charge.

IMPORTANT: When evaluating the refrigerant charge, an indicated adjustment to the specified factory charge must always be very minimal. If a substantial adjustment is indicated, an abnormal condition exists somewhere in the cooling system, such as insufficient airflow across either coil or both coils.

1. Remove caps from low- and high-pressure service fittings.
2. Using hoses with valve core depressors, attach low- and high-pressure gauge hoses to low- and high-pressure service fittings, respectively.
3. Start unit and let run until system pressures stabilize.
4. Measure and record the following:
 - a. Outdoor ambient-air temperature (°F [°C] db).
 - b. Liquid line temperature (°F [°C]) at TXV.
 - c. Discharge (high-side) pressure (psig).
 - d. Suction (low-side) pressure (psig) (for reference only).
5. Using Cooling Charging Charts (See Fig. 15) compare outdoor-air temperature (°F [°C] db) with the discharge line pressure (psig) to determine desired system operating liquid line temperature (See Fig. 15).
6. Compare actual liquid line temperature with desired liquid line temperature. Using a tolerance of $\pm 2^\circ\text{F}$ ($\pm 1.1^\circ\text{C}$), add refrigerant if actual temperature is more than 2°F (1.1°C) higher than proper liquid line temperature, or remove refrigerant if actual temperature is more than 2°F (1.1°C) lower than required liquid line temperature.

NOTE: If the problem causing the inaccurate readings is a refrigerant leak, refer to Check for Refrigerant Leaks section.

Indoor Airflow and Airflow Adjustments

⚠ CAUTION

UNIT OPERATION HAZARD

Failure to follow this caution may result in unit damage.

For cooling operation, the recommended airflow is 350 to 450 cfm for each 12,000 Btuh of rated cooling capacity. For heating operation, the airflow must produce a temperature rise that falls within the range stamped on the unit rating plate.

NOTE: Be sure that all supply-air and return-air grilles are open, free from obstructions, and adjusted properly.

⚠ WARNING

ELECTRICAL SHOCK HAZARD

Failure to follow this warning could result in personal injury or death.

Disconnect electrical power to the unit and install lockout tag before changing blower speed.

This unit has independent fan speeds for low stage cooling and high stage cooling. In addition, 208/230 VAC models have the field-selectable capability to run an enhanced dehumidification ('DEHUM') speed on high stage cooling (as low as 320 CFM per ton). Coupled with the improved dehumidification associated with low stage cooling, the DHUM speed allows for a complete dehumidification solution independent of cooling stage. Table 3 shows the operation modes and the associated fan speeds with each mode:

Table 3 – Operation Modes and Fan Speeds

208/230 VAC Models

Operation Mode	Fan Speed Tap Connection
Low Stage Cooling	LOW
High Stage Cooling	HIGH
High Stage Enhanced Dehumidification Cooling	DH
Continuous Fan	LOW

460 VAC Models

Operation Mode	Fan Speed Tap Connection
Low Stage Cooling	LOW
High Stage Cooling	HIGH
Continuous Fan	LOW

⚠ WARNING

ELECTRICAL SHOCK HAZARD

Failure to follow this warning could result in personal injury or death.

Disconnect electrical power to the unit and install lockout tag before changing blower speed.

The evaporator fan motor is factory set to provide 5 different fan speeds to choose from for the various operation modes (see Table 4). All models are factory-shipped for nominal high stage and low stage cooling airflow operation at minimum external static pressure. See Table 2.

Table 4 – Color Coding for Indoor Fan Motor Leads

Black = High Speed
Orange = Med-High Speed
Red = Med Speed
Pink = Med-Low Speed
Blue = Low Speed

Selection of Proper Fan Speeds for Operation Modes:

Low Stage Cooling (All Models): Using Tables 6, 7, and 8, find the external static pressure drops for wet coil, economizer, and filter, and add them to dry coil measured on the system. Using this total static pressure, look up Table 5 to find the airflows available at the total static pressure. For 208/230 VAC models, connect the chosen fan speed wire to "LO COOL" connection on the IFB Board (see Fig. 11). For 460 VAC models, connect the chosen fan speed wire to "LOW" connection on the IFB (see Fig. 11).

50VG--A

High Stage Cooling (All Models): Using Table 6, 7, and 8, find the external static pressure drops for wet coil, economizer, and filter, and add them to dry coil measured on the system. Using this total static pressure, look up Table 5 to find the airflows available at the total static pressure. The speed chosen must provide airflow of between 350 to 450 CFM per ton of cooling. For 208/230 VAC models, connect the chosen fan speed wire to “HI COOL” connection on the IFB Board (See Fig. 11). For 460 VAC models, connect the chosen fan speed wire to “HIGH” connection on the IFB (see Fig. 11).

High Stage Enhanced Dehumidification Cooling (208/230 VAC Models): Using the total static pressure for selecting the high stage cooling speed, look up Table 5 to find lower speed/airflows available at that total static pressure. All airflows highlighted in Table 5 are acceptable for the Dehum speed. The speed chosen must provide airflow of between 320 to 400 CFM per ton of cooling. To activate the high stage enhanced dehumidification cooling mode, the shunt jumper must be moved from the “No DH” to the “DH” selection. (See Fig. 11, close up.) For 208/230 VAC models, connect the chosen fan speed wire to “DHUM” connection on the IFB Board (see Fig. 11).

Continuous Fan (All Models): Continuous fan speed is the same speed as Low Stage Cooling.

To activate the high stage enhanced dehumidification cooling mode, the shunt jumper in Fig. 11 must be moved from the No DH to DH selection (See Fig. 11, close up).

Using the Same Fan Speed for More than One Mode: Some fan speeds are ideal for more than one mode of operation. It is permissible to use a field-supplied jumper wire to connect one speed tap wire to two or more speed connections on the Interface Fan Board (IFB). Jumper wires must use 18 AWG wire with at least 2/64” insulation.

COOLING SEQUENCE OF OPERATION

- a. Continuous Fan
 - (1.) Thermostat closes circuit R to G energizing the blower motor for continuous fan. The indoor fan is energized on low speed.
- b. Cooling Mode
 - (1.) Low Stage: Thermostat closes R to G, R to Y1. The compressor and indoor fan are energized on low speed. The outdoor fan is also energized
 - (2.) High Stage: Thermostat closes R to G, R to Y1, R to Y2. The compressor and indoor fan are energized on high speed. The outdoor fan is also energized.
- c. Electric Heating Mode
 - (1.) Thermostat closes circuit R to W2 or W3, and R to G. There are no on or off delays.

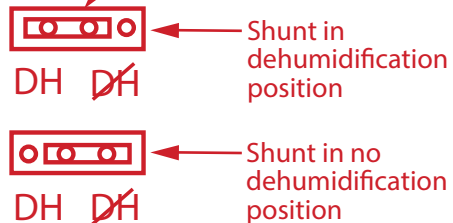
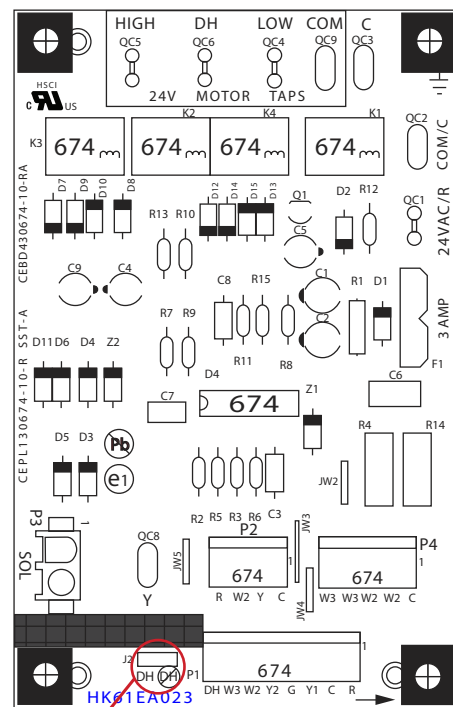

208/230 VAC Models

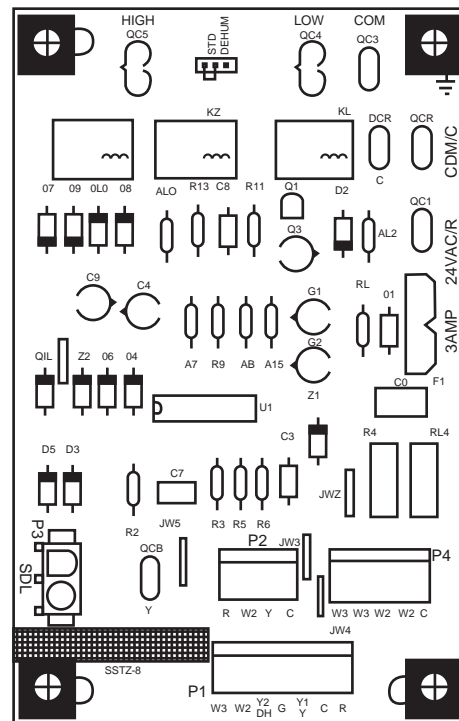

460 VAC Models

Fig. 11 - Interface Fan Board (IFB)

50VG--A

A12571

A09059

Table 5 – Dry Coil Air Delivery* - Horizontal and Downflow Discharge 208/230V Models - Unit 50VG-A24-60

UNIT	MOTOR SPEED	WIRE COLOR	EXTERNAL STATIC PRESSURE (IN. W.C.)																		
			0.1	0.2	0.3	0.4	0.5	0.6	0.7	0.8	0.9	1.0									
50VG -- A24	Low ¹	CFM	689	597	489	352	---	---	---	---	---	---	---	---	---	---	---	---	---	---	
		BHP	0.08	0.06	0.06	0.05	---	---	---	---	---	---	---	---	---	---	---	---	---	---	---
	Med-Low	CFM	777	692	583	465	318	---	---	---	---	---	---	---	---	---	---	---	---	---	---
		BHP	0.09	0.10	0.10	0.11	0.12	---	---	---	---	---	---	---	---	---	---	---	---	---	---
	Medium ²	CFM	921	829	754	663	582	485	371	---	---	---	---	---	---	---	---	---	---	---	---
		BHP	0.14	0.14	0.15	0.16	0.17	0.17	0.18	---	---	---	---	---	---	---	---	---	---	---	---
	Med-High	CFM	1229	1171	1105	1049	980	913	838	775	679	516	---	---	---	---	---	---	---	---	---
		BHP	0.28	0.30	0.30	0.31	0.32	0.33	0.33	0.34	0.34	0.33	---	---	---	---	---	---	---	---	---
	High	CFM	1291	1206	1142	1081	1017	951	888	823	753	668	---	---	---	---	---	---	---	---	---
		BHP	0.31	0.32	0.33	0.34	0.34	0.35	0.36	0.36	0.37	0.37	---	---	---	---	---	---	---	---	---
50VG -- A30	Low	CFM	777	692	583	465	318	---	---	---	---	---	---	---	---	---	---	---	---	---	---
		BHP	0.09	0.10	0.10	0.11	0.12	---	---	---	---	---	---	---	---	---	---	---	---	---	---
	Med-Low ¹	CFM	831	765	670	586	466	299	---	---	---	---	---	---	---	---	---	---	---	---	---
		BHP	0.11	0.12	0.12	0.13	0.13	0.14	---	---	---	---	---	---	---	---	---	---	---	---	---
	Medium ²	CFM	1139	1069	1012	937	870	786	724	626	512	381	---	---	---	---	---	---	---	---	---
		BHP	0.22	0.23	0.24	0.24	0.25	0.26	0.26	0.27	0.27	0.28	---	---	---	---	---	---	---	---	---
	Med-High	CFM	1229	1171	1105	1049	980	913	838	775	679	516	---	---	---	---	---	---	---	---	---
		BHP	0.28	0.30	0.30	0.31	0.32	0.33	0.33	0.34	0.34	0.33	---	---	---	---	---	---	---	---	---
	High	CFM	1531	1460	1382	1301	1209	1114	1003	890	764	629	---	---	---	---	---	---	---	---	---
		BHP	0.53	0.52	0.50	0.48	0.46	0.44	0.42	0.40	0.37	0.35	---	---	---	---	---	---	---	---	---
50VG -- A36	Low	CFM	1097	971	823	747	669	636	558	513	456	412	---	---	---	---	---	---	---	---	---
		BHP	0.12	0.11	0.10	0.11	0.12	0.13	0.13	0.13	0.14	0.15	0.16	---	---	---	---	---	---	---	---
	Med-Low ¹	CFM	934	864	810	745	698	649	571	525	486	428	---	---	---	---	---	---	---	---	---
		BHP	0.10	0.10	0.11	0.12	0.13	0.14	0.14	0.15	0.16	0.17	---	---	---	---	---	---	---	---	---
	Medium ²	CFM	1251	1198	1149	1104	1066	1017	970	932	892	839	---	---	---	---	---	---	---	---	---
		BHP	0.19	0.21	0.21	0.23	0.24	0.25	0.26	0.27	0.28	0.29	---	---	---	---	---	---	---	---	---
	Med-High	CFM	1451	1415	1372	1327	1287	1249	1212	1168	1130	1094	---	---	---	---	---	---	---	---	---
		BHP	0.29	0.30	0.31	0.32	0.32	0.35	0.36	0.37	0.38	0.39	---	---	---	---	---	---	---	---	---
	High	CFM	1466	1423	1384	1343	1308	1263	1219	1183	1145	1106	---	---	---	---	---	---	---	---	---
		BHP	0.30	0.31	0.33	0.34	0.35	0.36	0.37	0.38	0.40	0.41	---	---	---	---	---	---	---	---	---

Table 5 - Dry Coil Air Delivery* - Horizontal and Downflow Discharge 208/230V Models (CONT)- Unit 50VG-A24-60

UNIT	MOTOR SPEED	WIRE COLOR	EXTERNAL STATIC PRESSURE (IN. W.C.)										
			0.1	0.2	0.3	0.4	0.5	0.6	0.7	0.8	0.9	1.0	
50VG -- A42	Low	CFM	1097	971	823	747	669	636	558	513	456	412	
		BHP	0.12	0.11	0.10	0.11	0.12	0.13	0.13	0.14	0.15	0.16	
	Med-Low ¹	CFM	1076	1026	972	918	872	827	771	714	666	611	
		BHP	0.13	0.14	0.15	0.15	0.17	0.18	0.18	0.20	0.21	0.22	
	Medium	CFM	1251	1198	1149	1104	1066	1017	970	932	892	839	
		BHP	0.19	0.21	0.21	0.23	0.24	0.25	0.26	0.27	0.28	0.29	
	Med-High ²	CFM	1451	1415	1372	1327	1287	1249	1212	1168	1130	1094	
		BHP	0.29	0.30	0.31	0.32	0.35	0.36	0.36	0.37	0.38	0.39	
	High	CFM	1633	1590	1552	1518	1483	1444	1406	1372	1340	1303	
		BHP	0.41	0.43	0.44	0.45	0.47	0.48	0.49	0.50	0.51	0.53	
	50VG -- A48	Low ¹	CFM	1271	1229	1177	1121	1066	1027	974	942	887	839
			BHP	0.19	0.20	0.21	0.23	0.24	0.25	0.26	0.27	0.28	0.29
Med-Low		CFM	1340	1299	1240	1191	1139	1091	1050	1001	952	895	
		BHP	0.22	0.23	0.24	0.25	0.26	0.28	0.29	0.30	0.31	0.32	
Medium ²		CFM	1686	1650	1617	1576	1544	1503	1468	1433	1393	1356	
		BHP	0.42	0.44	0.45	0.46	0.48	0.49	0.51	0.52	0.53	0.55	
Med-High		CFM	1854	1837	1781	1784	1720	1698	1655	1625	1578	1532	
		BHP	0.56	0.57	0.60	0.59	0.62	0.63	0.64	0.66	0.67	0.67	
High		CFM	1934	1900	1855	1815	1778	1737	1695	1656	1606	1528	
		BHP	0.59	0.61	0.62	0.64	0.65	0.67	0.68	0.70	0.70	0.68	
Low ¹		CFM	1271	1229	1177	1121	1066	1027	974	942	887	839	
		BHP	0.19	0.20	0.21	0.23	0.24	0.25	0.26	0.27	0.28	0.29	
Med-Low	CFM	1340	1299	1240	1191	1139	1091	1050	1001	952	895		
	BHP	0.22	0.23	0.24	0.25	0.26	0.28	0.29	0.30	0.31	0.32		
Medium	CFM	1686	1650	1617	1576	1544	1503	1468	1433	1393	1356		
	BHP	0.42	0.44	0.45	0.46	0.48	0.49	0.51	0.52	0.53	0.55		
Med-High ²	CFM	1878	1844	1805	1762	1731	1693	1655	1616	1570	1532		
	BHP	0.50	0.52	0.53	0.54	0.56	0.57	0.59	0.60	0.64	0.63		
High	CFM	1934	1900	1855	1815	1778	1737	1695	1656	1606	1528		
	BHP	0.59	0.61	0.62	0.64	0.65	0.67	0.68	0.70	0.70	0.68		

* Air delivery values are without air filter and are for dry coil (See 50VG-A Wet Coil Pressure Drop table).

1 Factory-shipped low stage cooling speed.

2 Factory-shipped high stage cooling speed.

Note: Duct field-supplied air filter pressure drop and wet coil pressure drop to obtain external static pressure available for ducting.
 Shaded areas indicate acceptable Dehum. Speeds (Dehum. Mode is High Stage Only, 208/230 VAC Models Only).

Table 5 - Dry Coil Air Delivery* - Horizontal and Downflow Discharge 460VAC Models- Unit 50VG--A36-60

UNIT	MOTOR SPEED	WIRE COLOR	EXTERNAL STATIC PRESSURE (IN. W.C.)										
			0.1	0.2	0.3	0.4	0.5	0.6	0.7	0.8	0.9	1.0	
50VG -- A36	Low ¹	Blue	CFM	934	864	810	745	698	649	571	525	486	428
			BHP	0.10	0.10	0.11	0.12	0.13	0.14	0.14	0.15	0.16	0.17
	Med-Low	Pink	CFM	1076	1026	972	918	872	827	771	714	666	611
			BHP	0.13	0.14	0.15	0.15	0.17	0.18	0.18	0.20	0.21	0.22
	Medium	Red	CFM	1213	1169	1110	1065	1016	964	923	878	820	777
			BHP	0.16	0.17	0.17	0.19	0.20	0.21	0.22	0.23	0.24	0.25
	Med-High ²	Orange	CFM	1251	1198	1149	1104	1066	1017	970	932	892	839
			BHP	0.19	0.21	0.21	0.23	0.24	0.25	0.26	0.27	0.28	0.29
	High	Black	CFM	1451	1415	1372	1327	1287	1249	1212	1168	1130	1094
			BHP	0.29	0.30	0.31	0.32	0.35	0.36	0.37	0.38	0.39	0.40
Low ¹	Blue	CFM	1076	1026	972	918	872	827	771	714	666	611	
		BHP	0.13	0.14	0.15	0.15	0.17	0.18	0.18	0.20	0.21	0.22	
Med-Low	Pink	CFM	1213	1169	1110	1065	1016	964	923	878	820	777	
		BHP	0.16	0.17	0.17	0.19	0.20	0.21	0.22	0.23	0.24	0.25	
Medium	Red	CFM	1251	1198	1149	1104	1066	1017	970	932	892	839	
		BHP	0.19	0.21	0.21	0.23	0.24	0.25	0.26	0.27	0.28	0.29	
Med-High ²	Orange	CFM	1451	1415	1372	1327	1287	1249	1212	1168	1130	1094	
		BHP	0.29	0.30	0.31	0.32	0.35	0.36	0.37	0.38	0.39	0.40	
High	Black	CFM	1633	1590	1552	1518	1483	1444	1406	1372	1340	1303	
		BHP	0.41	0.43	0.44	0.45	0.47	0.48	0.49	0.50	0.51	0.53	
Low ¹	Blue	CFM	1271	1229	1177	1121	1066	1027	974	942	887	839	
		BHP	0.19	0.20	0.21	0.23	0.24	0.25	0.26	0.27	0.28	0.29	
Med-Low	Pink	CFM	1445	1389	1341	1281	1236	1189	1139	1072	1027	982	
		BHP	0.24	0.26	0.26	0.28	0.29	0.30	0.32	0.33	0.34	0.35	
Medium ²	Red	CFM	1686	1650	1617	1576	1544	1503	1468	1433	1393	1356	
		BHP	0.42	0.44	0.45	0.46	0.48	0.49	0.51	0.52	0.53	0.55	
Med-High	Orange	CFM	1854	1837	1781	1784	1720	1698	1655	1625	1578	1532	
		BHP	0.56	0.57	0.60	0.59	0.62	0.63	0.64	0.66	0.67	0.67	
High	Black	CFM	2131	2088	2065	2013	1982	1941	1888	1860	1785	1751	
		BHP	0.72	0.74	0.75	0.77	0.79	0.80	0.81	0.81	0.79	0.75	

Table 5 - Dry Coil Air Delivery* - Horizontal and Downflow Discharge 460VAC Models- (CONT) Unit 50VG-A36-60

UNIT	MOTOR SPEED	WIRE COLOR	EXTERNAL STATIC PRESSURE (IN. W.C.)									
			0.1	0.2	0.3	0.4	0.5	0.6	0.7	0.8	0.9	1.0
50VG -- A60	Low ¹	Blue	CFM 1271	1229	1177	1121	1066	1027	974	942	887	839
		BHP	0.19	0.20	0.21	0.23	0.24	0.25	0.26	0.27	0.28	0.29
	Med-Low	Pink	CFM 1445	1389	1341	1281	1236	1189	1139	1072	1027	982
		BHP	0.24	0.26	0.26	0.28	0.29	0.30	0.32	0.33	0.34	0.35
	Medium ²	Red	CFM 1878	1844	1805	1762	1731	1693	1655	1616	1570	1532
		BHP	0.50	0.52	0.53	0.54	0.56	0.57	0.59	0.60	0.64	0.63
	Med-High	Orange	CFM 2020	1990	1956	1912	1872	1842	1802	1760	1719	1643
		BHP	0.62	0.63	0.66	0.67	0.69	0.70	0.71	0.73	0.74	0.72
	High	Black	CFM 2131	2088	2065	2013	1982	1941	1888	1860	1785	1751
		BHP	0.72	0.74	0.75	0.77	0.79	0.80	0.81	0.81	0.79	0.75

* Air delivery values are without air filter and are for dry coil (See 50VG-A Wet Coil Pressure Drop table).

1 Factory-shipped low stage cooling speed.

2 Factory-shipped high stage cooling speed.

Note: Deduct field-supplied air filter pressure drop and wet coil pressure drop to obtain external static pressure available for ducting.

Table 6 – Wet Coil Pressure Drop (IN. W.C.)

UNIT SIZE	STANDARD CFM (SCFM)																
	600	700	800	900	1000	1100	1200	1300	1400	1500	1600	1700	1800	1900	2000	2100	2200
24	0.03	0.04	0.05	0.06	0.07												
30				0.06	0.07	0.07	0.08	0.09									
36				0.06	0.07	0.08	0.09	0.10	0.11								
42				0.06	0.07	0.08	0.09	0.10	0.11	0.11	0.12	0.12					
48						0.03	0.04	0.08	0.08	0.08	0.10	0.11	0.14	0.15	0.16		
60								0.08	0.08	0.10	0.10	0.11	0.14	0.15	0.16	0.16	

Table 7 – Economizer with 1-in. Filter Pressure Drop (IN. W.C.)

FILTER SIZE IN. (MM)	COOLING TONS	STANDARD CFM (SCFM)																
		600	700	800	900	1000	1100	1200	1300	1400	1500	1600	1700	1800	1900	2000	2100	2200
600-1400CFM 12x20x1+12x20x1 (305x508x25+305x508x25)	2.0,	-	-	0.09	0.14	0.16	0.18	0.25	0.28	0.3	-	-	-	-	-	-	-	-
	2.5,																	
1200-1800 CFM 16x24x1+14x24x1 (406x610x25+356x610x25)	3.0	-	-	-	-	-	-	0.10	0.11	0.12	0.13	0.14	0.16	0.16	-	-	-	-
	3.5																	
1500-2200 CFM 16x24x1+18x24x1 (406x610x25+457x610x25)	4.0,	-	-	-	-	-	-	-	-	-	0.15	0.17	0.18	0.20	0.21	0.22	0.23	0.23
	5.0																	

Table 8 – Filter Pressure Drop Table (IN. W.C.)

FILTER SIZE IN. (MM)	COOLING TONS	STANDARD CFM (SCFM)																
		600	700	800	900	1000	1100	1200	1300	1400	1500	1600	1700	1800	1900	2000	2100	2200
600-1400CFM 12x20x1+12x20x1 (305x508x25+305x508x25)	2.0,	0.03	0.05	0.06	0.08	0.10	0.11	0.13	0.14	0.16	-	-	-	-	-	-	-	-
	2.5,																	
1200-1800 CFM 16x24x1+14x24x1 (406x610x25+356x610x25)	3.0	-	-	-	-	-	-	0.07	0.08	0.09	0.09	0.10	0.11	0.12	-	-	-	-
	3.5																	
1500-2200 CFM 16x24x1+18x24x1 (406x610x25+457x610x25)	4.0,	-	-	-	-	-	-	-	-	-	0.04	0.06	0.08	0.10	0.11	0.13	0.14	0.15
	5.0																	

**Table 9 – Electric Heat Pressure Drop Tables (IN. W.C.)
Small Cabinet: 24-30**

STATIC	STANDARD CFM (SCFM)															
	500	600	700	800	900	1000	1100	1200	1300	1400	1500	1600				
5 kW	0.00	0.00	0.00	0.00	0.00	0.00	0.00	0.00	0.02	0.02	0.04	0.06	0.07	0.09	0.10	0.11
10 kW	0.00	0.00	0.00	0.00	0.00	0.02	0.04	0.06	0.07	0.09	0.10	0.11	0.12	0.13	0.14	0.15
15 kW	0.00	0.00	0.00	0.02	0.04	0.06	0.08	0.10	0.12	0.14	0.16	0.18	0.19	0.20	0.21	0.22
20 kW	0.00	0.00	0.02	0.04	0.06	0.08	0.09	0.11	0.13	0.15	0.17	0.19	0.21	0.23	0.25	0.27

Large Cabinet: 36-60

STATIC	STANDARD CFM (SCFM)															
	1100	1200	1300	1400	1500	1600	1700	1800	1900	2000	2100	2200	2300	2400	2500	
5 kW	0.00	0.00	0.00	0.01	0.02	0.03	0.04	0.05	0.06	0.07	0.08	0.09	0.10	0.11	0.12	
10 kW	0.00	0.00	0.01	0.02	0.03	0.04	0.05	0.06	0.07	0.08	0.09	0.10	0.11	0.12	0.13	
15 kW	0.00	0.02	0.03	0.04	0.05	0.06	0.07	0.08	0.09	0.10	0.11	0.12	0.13	0.14	0.15	
20 kW	0.02	0.03	0.04	0.05	0.06	0.07	0.08	0.09	0.10	0.11	0.12	0.13	0.14	0.15	0.16	

CONNECTION WIRING DIAGRAM

DANGER: ELECTRICAL SHOCK HAZARD DISCONNECT POWER BEFORE SERVICING

SCHEMATIC 208/230V-1-60

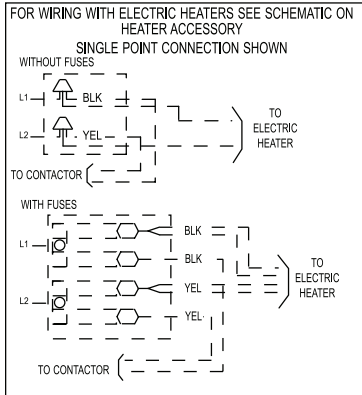

50VG--A

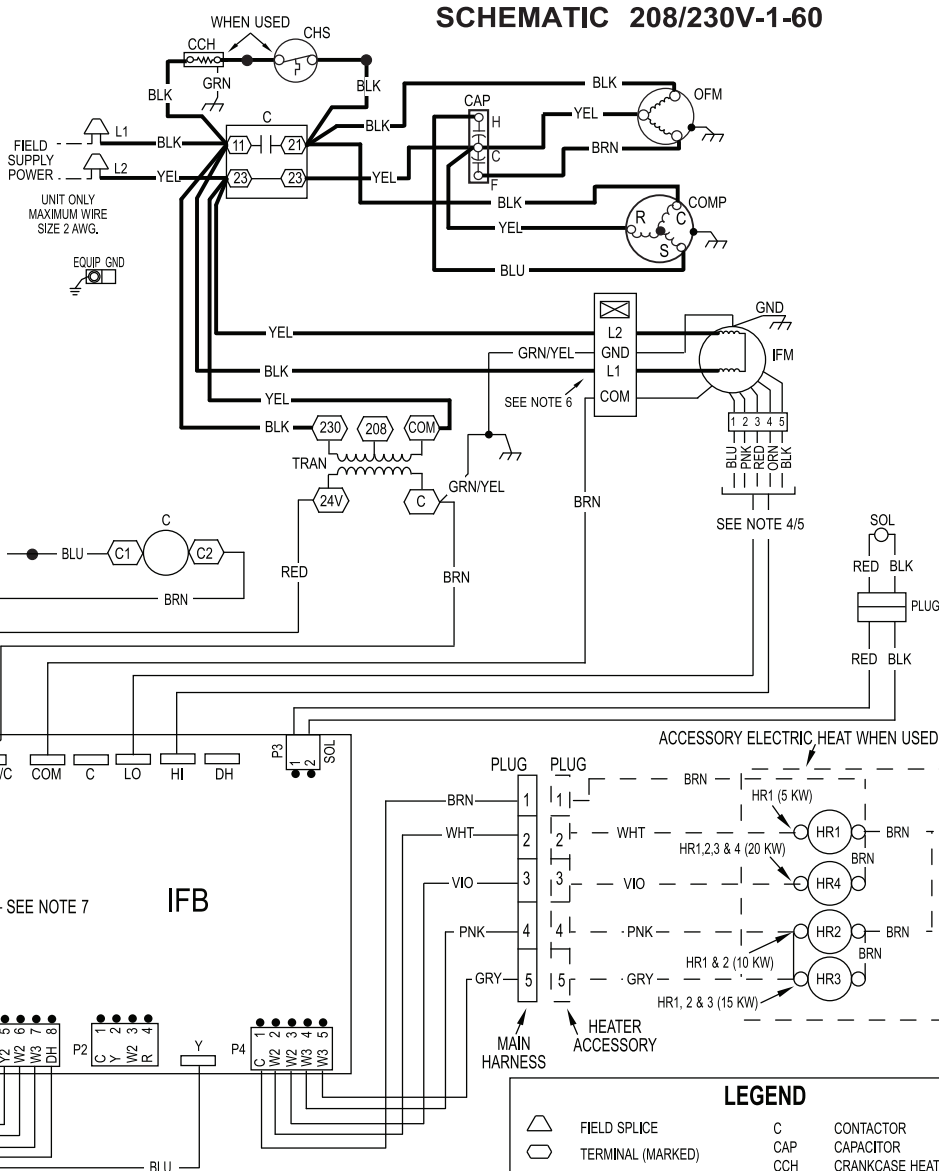

NOTES:

1. IF ANY OF THE ORIGINAL WIRES FURNISHED ARE REPLACED IT MUST BE REPLACED WITH THE SAME OR IT'S EQUIVALENT.
2. SEE PRE SALE LITERATURE FOR THERMOSTATS.
3. USE 75 DEGREES C COPPER CONDUCTORS FOR FIELD INSTALLATION.
4. REFER TO INSTALLATION INSTRUCTIONS FOR CORRECT SPEED SELECTION FOR IFM.
5. RELOCATION OF SPEED TAPS MAY BE REQUIRED WHEN USING FIELD INSTALLED ELECTRIC HEATERS. CONSULT INSTALLATION INSTRUCTIONS TO DETERMINE CORRECT SPEED TAP SETTING.
6. "DO NOT DISCONNECT PLUG UNDER LOAD".
7. THIS FUSE IS MANUFACTURED BY LITTLE FUSE, P/N 287003.

LEGEND

	FIELD SPLICE	C	CONTACTOR
	TERMINAL (MARKED)	CAP	CAPACITOR
	TERMINAL (UNMARKED)	CCH	CRANKCASE HEATER
	SPLICE	CHS	CRANKCASE HEATER SWITCH
	SPLICE (MARKED)	COMP	COMPRESSOR MOTOR
	FACTORY LO VOLTAGE	CTD	COMPRESSOR TIME DELAY
	FIELD CONTROL WIRING	DH	DEHUM
	FIELD POWER WIRING	GND	GROUND
	ACCESSORY OR OPTIONAL WIRING	HPS	HIGH PRESSURE SWITCH
	FACTORY HI VOLTAGE	HR	HEATER RELAY
		IFB	INDOOR FAN BOARD
		IFM	INDOOR FAN MOTOR
		LPS	LOW PRESSURE SWITCH
		OFM	OUTDOOR FAN MOTOR
		SOL	COMPRESSOR SOLENOID
		TRAN	TRANSFORMER
		T-STAT	THERMOSTAT

Fig. 12 - Connection Wiring Diagram 208/230-1-60

A12572

LADDER WIRING DIAGRAM

DANGER: ELECTRICAL SHOCK HAZARD DISCONNECT POWER BEFORE SERVICING

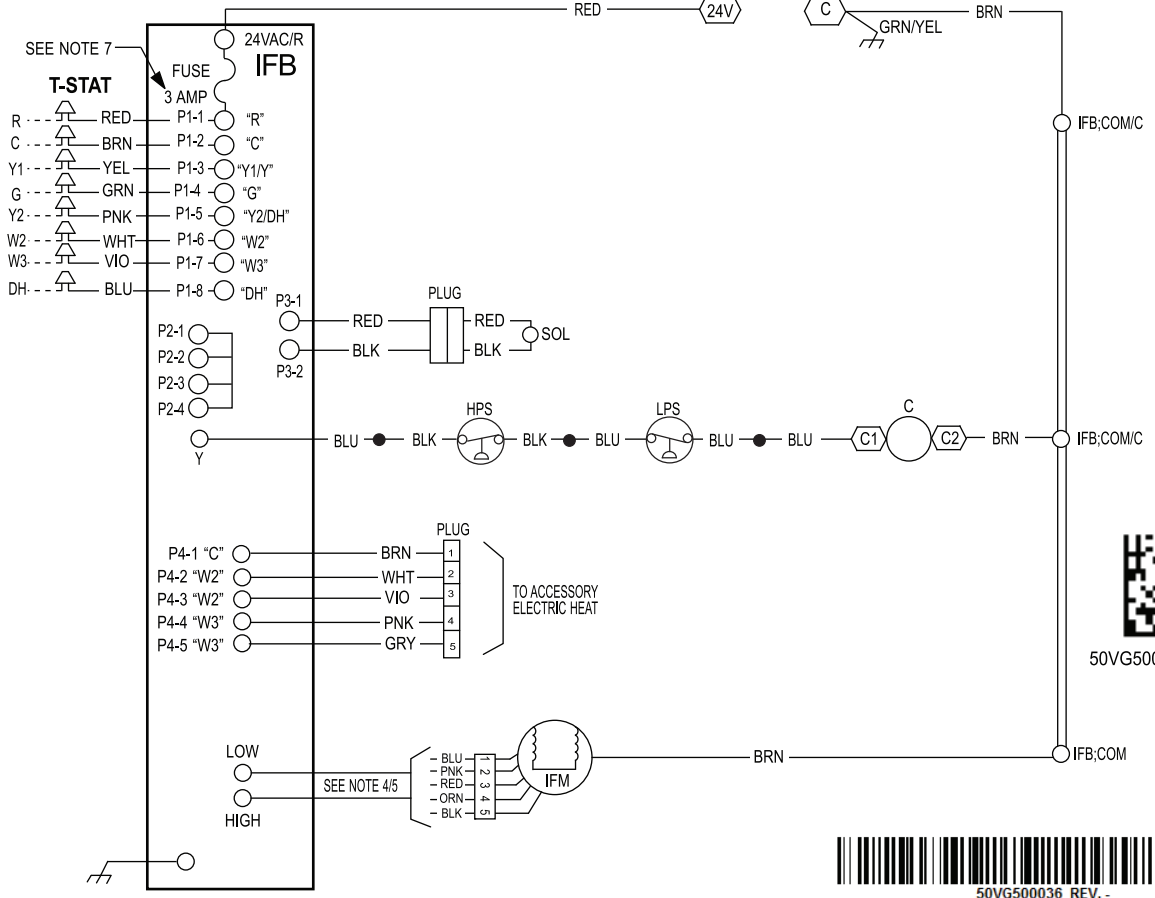
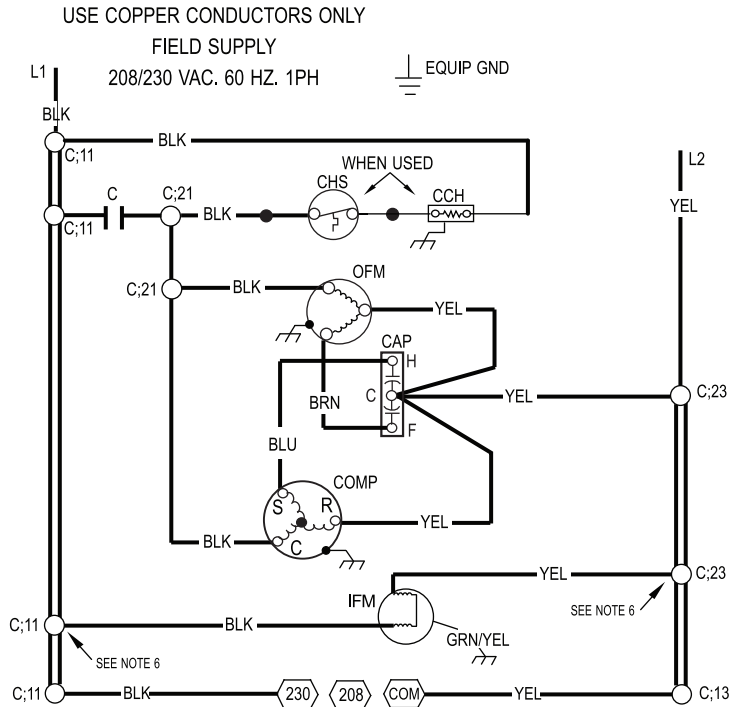
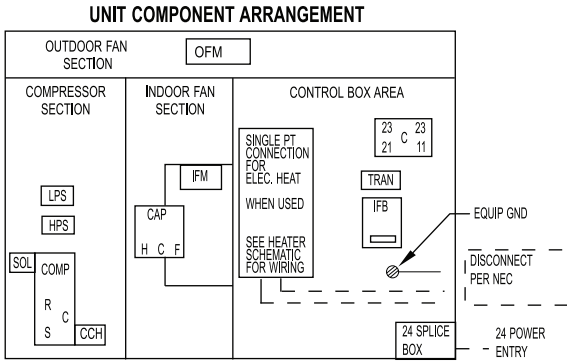

50VG--A



50VG500036 REV. -



Fig. 12 Cont. - Ladder Wiring Diagram 208/230-1-60

A12573

CONNECTION WIRING DIAGRAM
DANGER: ELECTRICAL SHOCK HAZARD DISCONNECT POWER BEFORE SERVICING

SCHEMATIC 208/230V-3-60

50VG--A

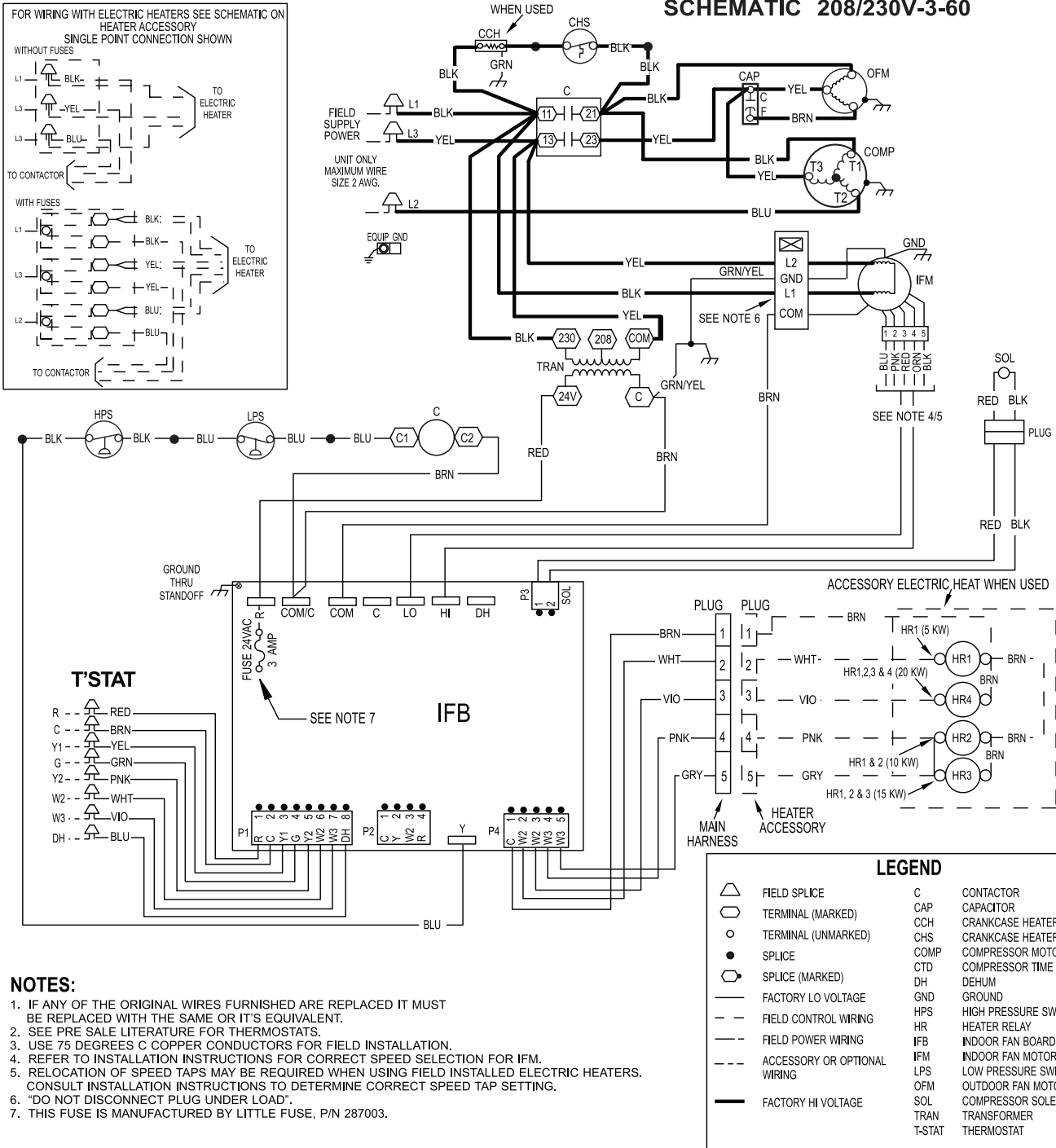

NOTES:

1. IF ANY OF THE ORIGINAL WIRES FURNISHED ARE REPLACED IT MUST BE REPLACED WITH THE SAME OR IT'S EQUIVALENT.
2. SEE PRE SALE LITERATURE FOR THERMOSTATS.
3. USE 75 DEGREES C COPPER CONDUCTORS FOR FIELD INSTALLATION.
4. REFER TO INSTALLATION INSTRUCTIONS FOR CORRECT SPEED SELECTION FOR IFM.
5. RELOCATION OF SPEED TAPS MAY BE REQUIRED WHEN USING FIELD INSTALLED ELECTRIC HEATERS. CONSULT INSTALLATION INSTRUCTIONS TO DETERMINE CORRECT SPEED TAP SETTING.
6. "DO NOT DISCONNECT PLUG UNDER LOAD".
7. THIS FUSE IS MANUFACTURED BY LITTLE FUSE, P/N 287003.

Fig. 13 - Connection Wiring Diagram 208/230-3-60

A12574

LADDER WIRING DIAGRAM

DANGER: ELECTRICAL SHOCK HAZARD DISCONNECT POWER BEFORE SERVICING

UNIT COMPONENT ARRANGEMENT

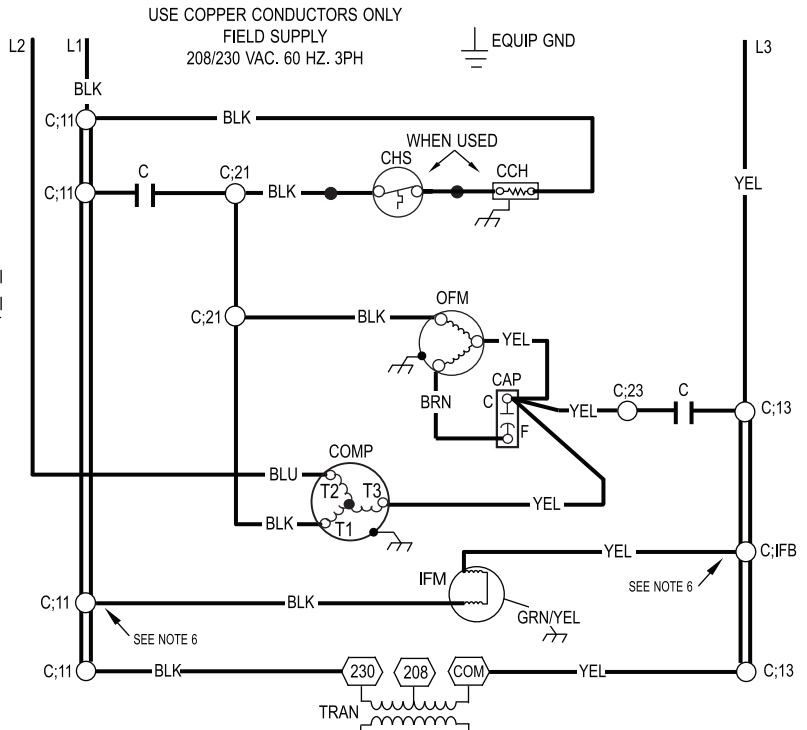
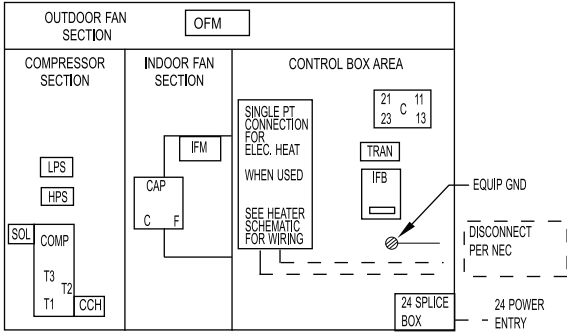

50VG--A

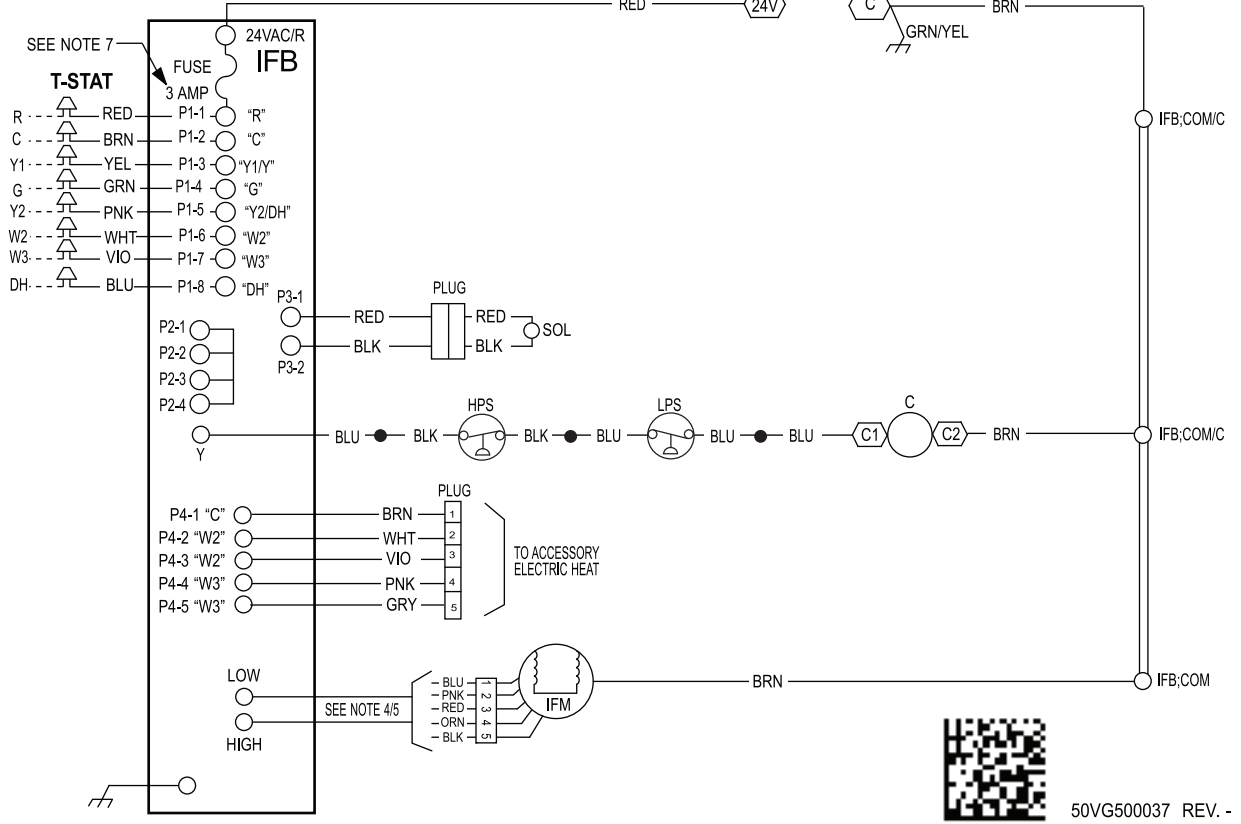

50VG500037 REV. -



50VG500037 REV. -

A12575

Fig. 13 Cont. - Ladder Wiring Diagram 208/230-3-60

CONNECTION WIRING DIAGRAM
DANGER: ELECTRICAL SHOCK HAZARD DISCONNECT POWER BEFORE SERVICING

SCHEMATIC 460-3-60

50VG--A

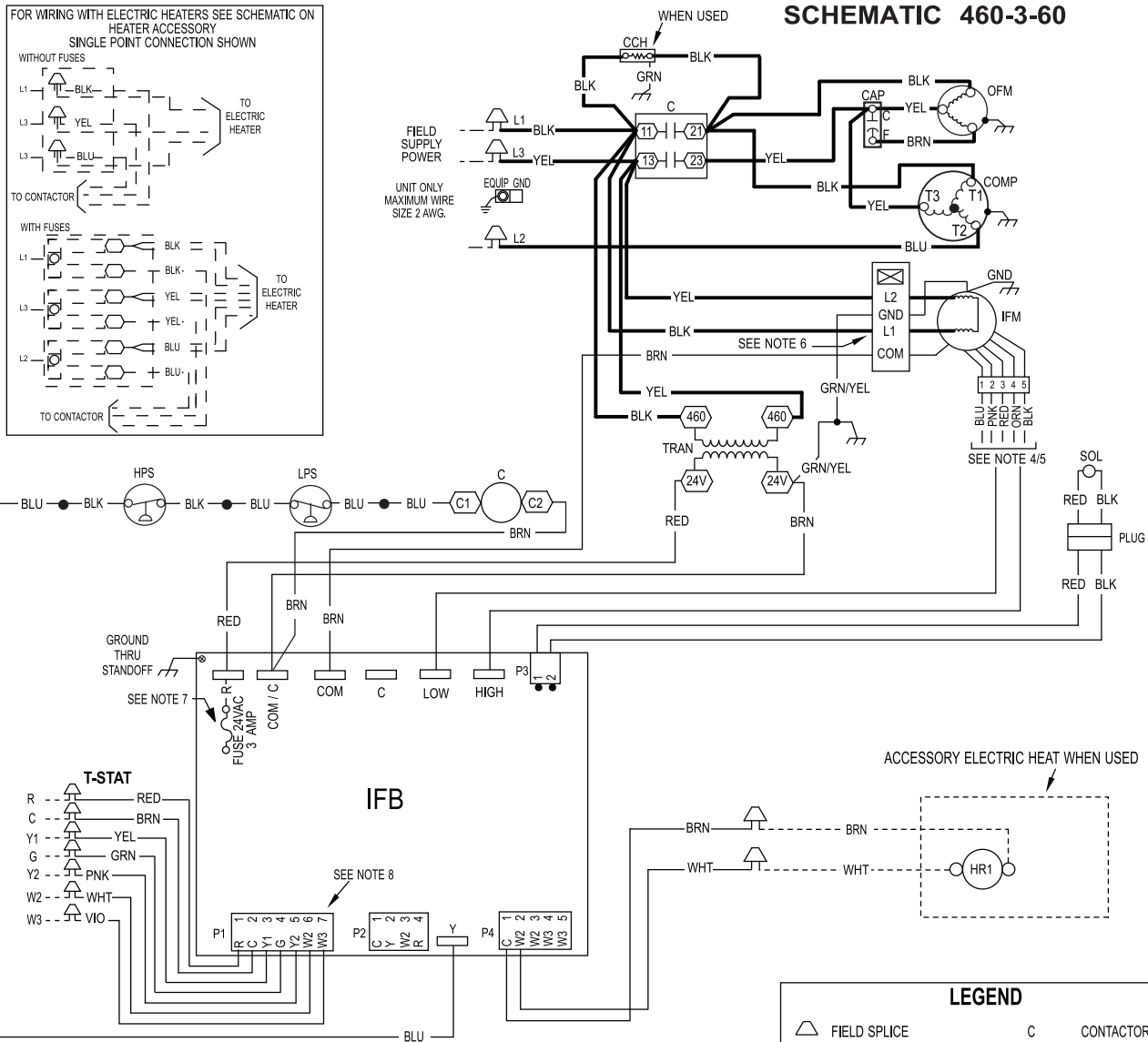

NOTES:

1. IF ANY OF THE ORIGINAL WIRES FURNISHED ARE REPLACED IT MUST BE REPLACED WITH THE SAME OR IT'S EQUIVALENT.
2. SEE PRE SALE LITERATURE FOR THERMOSTATS.
3. USE 75 DEGREES C COPPER CONDUCTORS FOR FIELD INSTALLATION.
4. REFER TO INSTALLATION INSTRUCTIONS FOR CORRECT SPEED SELECTION FOR IFM.
5. RELOCATION OF SPEED TAPS MAY BE REQUIRED WHEN USING FIELD INSTALLED ELECTRIC HEATERS. CONSULT INSTALLATION INSTRUCTIONS TO DETERMINE CORRECT SPEED TAP SETTING.
6. "DO NOT DISCONNECT PLUG UNDER LOAD".
7. THIS FUSE IS MANUFACTURED BY LITTLE FUSE, P/N 287003.
8. DEHUM FEATURE IS NOT AVAILABLE IN THESE UNITS.

LEGEND			
	FIELD SPLICE	C	CONTACTOR
	TERMINAL (MARKED)	CAP	CAPACITOR
	TERMINAL (UNMARKED)	CCH	CRANK CASE HEATER
	SPLICE	COMP	COMPRESSOR MOTOR
	SPLICE (MARKED)	CS	COMPRESSOR SOLENOID
	FACTORY LO VOLTAGE	GND	GROUND
	FIELD CONTROL WIRING	HPS	HIGH PRESSURE SWITCH
	FIELD POWER WIRING	HR	HEATER RELAY
	ACCESSORY OR OPTIONAL WIRING	IFB	INDOOR FAN BOARD
	FACTORY HI VOLTAGE	IFM	INDOOR FAN MOTOR
		LPS	LOW PRESSURE SWITCH
		OFM	OUTDOOR FAN MOTOR
		TRAN	TRANSFORMER
		T-STAT	THERMOSTAT

Fig. 14 - Connection Wiring Diagram 460-3-60

A12576

LADDER WIRING DIAGRAM
DANGER: ELECTRICAL SHOCK HAZARD DISCONNECT POWER BEFORE SERVICING

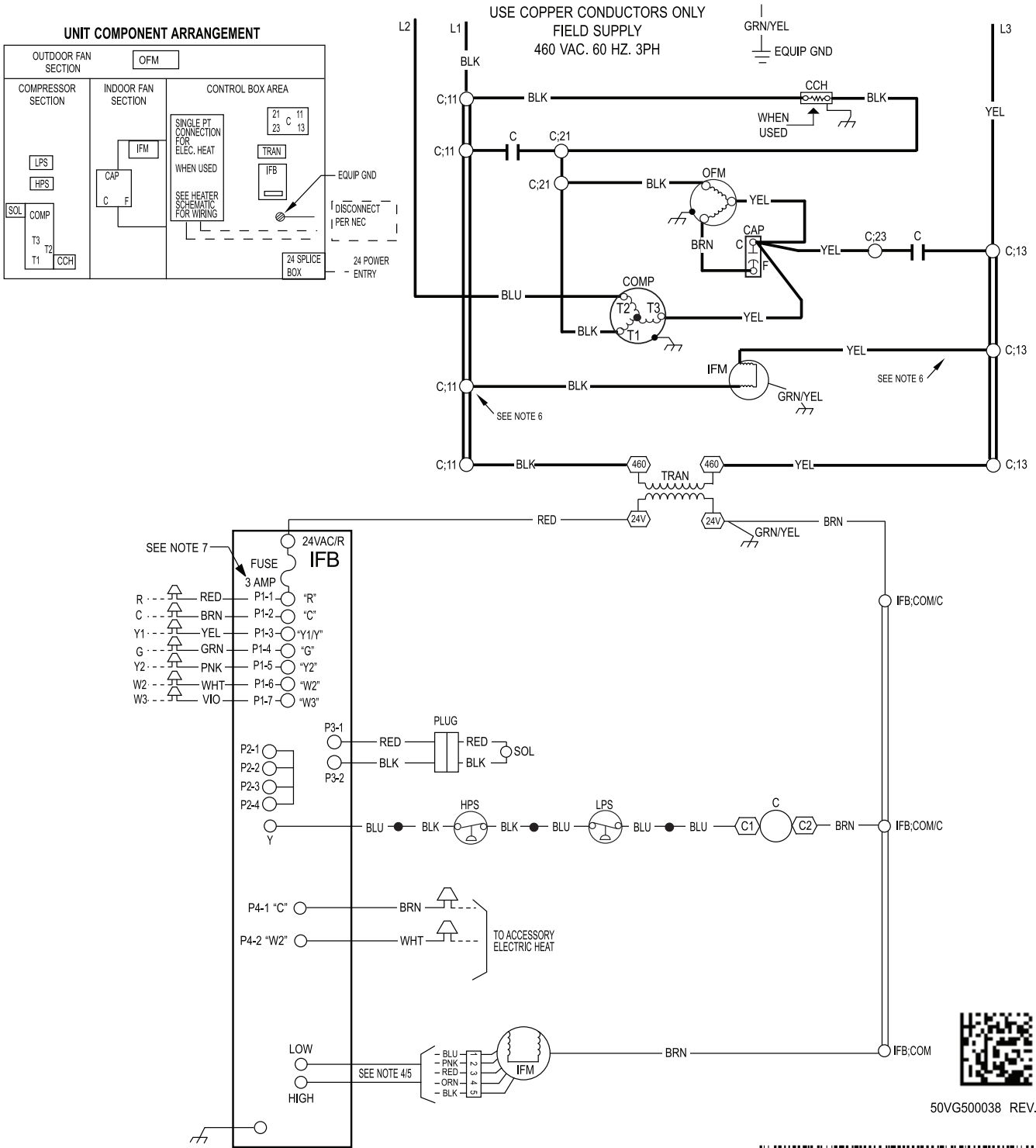

Fig. 14 Cont. - Ladder Wiring Diagram 460-3-60

A12577

50VG--A

Model Size	Required Subcooling °F(°C)					Pressure (psig)	Required Liquid Line Temperature for a Specific Subcooling (R-410A)					Pressure (kPa)	Required Subcooling (°C)				
	Outdoor Ambient Temperature °F(°C)						Required Subcooling (°F)						Required Subcooling (°C)				
	75 (24)	85 (29)	95 (35)	105 (41)	115 (46)		5	10	15	20	25		3	6	8	11	14
						189	61	56	51	46	41	1303	16	13	11	8	5
024	15 (8.2)	15 (8.2)	13 (7.5)	11 (6.2)	11 (6.2)	196	63	58	53	48	43	1351	17	15	12	9	6
030	12 (6.9)	12 (6.9)	12 (6.9)	11 (6.2)	11 (6.2)	203	66	61	56	51	46	1399	19	16	13	10	8
036	12 (6.9)	12 (6.9)	12 (6.9)	11 (6.2)	10 (5.6)	210	68	63	58	53	48	1448	20	17	14	11	9
042	15 (8.2)	14 (7.8)	14 (7.8)	12 (6.9)	11 (6.2)	217	70	65	60	55	50	1496	21	18	15	13	10
048	14 (7.8)	13 (7.5)	13 (7.5)	13 (7.5)	12 (6.9)	224	72	67	62	57	52	1544	22	19	16	14	11
060	18 (9.9)	18 (9.9)	18 (9.9)	17 (9.4)	17 (9.4)	231	74	69	64	59	54	1593	23	20	18	15	12
						238	76	71	66	61	56	1641	24	21	19	16	13
						245	77	72	67	62	57	1689	25	22	20	17	14
						252	79	74	69	64	59	1737	26	23	21	18	15
						260	81	76	71	66	61	1792	27	25	22	19	16
						268	83	78	73	68	63	1848	29	26	23	20	17
						276	85	80	75	70	65	1903	30	27	24	21	19
						284	87	82	77	72	67	1958	31	28	25	22	20
						292	89	84	79	74	69	2013	32	29	26	23	21
						300	91	86	81	76	71	2068	33	30	27	24	22
						309	93	88	83	78	73	2130	34	31	28	26	23
						318	95	90	85	80	75	2192	35	32	29	27	24
						327	97	92	87	82	77	2254	36	33	31	28	25
						336	99	94	89	84	79	2316	37	34	32	29	26
						345	101	96	91	86	81	2378	38	35	33	30	27
						354	103	98	93	88	83	2440	39	36	34	31	28
						364	105	100	95	90	85	2509	40	38	35	32	29
						374	107	102	97	92	87	2578	41	39	36	33	30
						384	108	103	98	93	88	2647	42	40	37	34	31
						394	110	105	100	95	90	2716	44	41	38	35	32
						404	112	107	102	97	92	2785	45	42	39	36	33
						414	114	109	104	99	94	2854	46	43	40	37	34
						424	116	111	106	101	96	2923	47	44	41	38	35
						434	118	113	108	103	98	2992	48	45	42	39	36
						444	119	114	109	104	99	3061	48	46	43	40	37
						454	121	116	111	106	101	3130	49	47	44	41	38
						464	123	118	113	108	103	3199	50	48	45	42	39
						474	124	119	114	109	104	3268	51	48	46	43	40
						484	126	121	116	111	106	3337	52	49	47	44	41
						494	127	122	117	112	107	3406	53	50	47	45	42
						504	129	124	119	114	109	3475	54	51	48	46	43
						514	131	126	121	116	111	3544	55	52	49	46	44
						524	132	127	122	117	112	3612	56	53	50	47	45
						534	134	129	124	119	114	3681	56	54	51	48	45

NOTE: Subcooling values calculated using High Stage.

Charging Procedure

1. Measure Discharge line pressure by attaching a gauge to the service port.
2. Measure the liquid line temperature by attaching a temperature sensing device to it.
3. Insulate the temperature sensing device so that the Outdoor Ambient doesn't affect the reading.
4. Refer to the required Subcooling in the table based on the model size and the Outdoor Ambient temperature.
5. Interpolate if the Outdoor ambient temperature lies in between the table values.
6. Find the Pressure Value in the table corresponding to the measured Pressure of the Compressor Discharge line.
7. Read across from the Pressure reading to obtain the liquid line temperature for a required Subcooling.
8. Add charge if the measured temperature is higher than the table value.
9. Remove charge if the measured temperature is lower than the table value.



50VG500083 REV. -



50VG500083 REV. -

Fig. 15 - Cooling Charging Chart

A12578

MAINTENANCE

To ensure continuing high performance, and to minimize the possibility of premature equipment failure, periodic maintenance must be performed on this equipment. This cooling unit should be inspected at least once each year by a qualified service person. To troubleshoot unit, refer to Table 10, Troubleshooting Chart.

NOTE TO EQUIPMENT OWNER: Consult your local dealer about the availability of a maintenance contract.

WARNING

PERSONAL INJURY AND UNIT DAMAGE HAZARD

Failure to follow this warning could result in personal injury or death and possible unit component damage.

The ability to properly perform maintenance on this equipment requires certain expertise, mechanical skills, tools and equipment. If you do not possess these, do not attempt to perform any maintenance on this equipment, other than those procedures recommended in the Owner's Manual.

WARNING

ELECTRICAL SHOCK AND FIRE HAZARD

Failure to follow these warnings could result in personal injury or death:

1. Turn off electrical power to the unit and install lockout tag before performing any maintenance or service on this unit.
2. Use extreme caution when removing panels and parts.
3. Never place anything combustible either on or in contact with the unit.

CAUTION

UNIT OPERATION HAZARD

Failure to follow this caution may result in equipment damage or improper operation.

Errors made when reconnecting wires may cause improper and dangerous operation. Label all wires prior to disconnecting when servicing.

The minimum maintenance requirements for this equipment are as follows:

1. Inspect air filter(s) each month. Clean or replace when necessary.
2. Inspect indoor coil, drain pan, and condensate drain each cooling season for cleanliness. Clean when necessary.
3. Inspect blower motor and wheel for cleanliness each cooling season. Clean when necessary.
4. Check electrical connections for tightness and controls for proper operation each cooling season. Service when necessary.
5. Ensure electric wires are not in contact with refrigerant tubing or sharp metal edges.

Air Filter

IMPORTANT: Never operate the unit without a suitable air filter in the return-air duct system. Always replace the filter with the same dimensional size and type as originally installed. See Table 1 for recommended filter sizes.

Inspect air filter(s) at least once each month and replace (throwaway-type) or clean (cleanable-type) at least twice during each cooling season and twice during the heating season, or whenever the filter becomes clogged with dust and lint.

Indoor Blower and Motor

NOTE: All motors are pre-lubricated. Do not attempt to lubricate these motors.

For longer life, operating economy, and continuing efficiency, clean accumulated dirt and grease from the blower wheel and motor annually.

WARNING

ELECTRICAL SHOCK HAZARD

Failure to follow this warning could result in personal injury or death.

Disconnect and tag electrical power to the unit before cleaning the blower motor and wheel.

To clean the blower motor and wheel:

1. Remove and disassemble blower assembly as follows:
 - a. Remove blower access panel (see Fig. 17).
 - b. Disconnect 5 pin plug and 4 pin plug from indoor blower motor. Remove capacitor if required.
 - c. On all units remove blower assembly from unit. Remove screws securing blower to blower partition and slide assembly out. Be careful not to tear insulation in blower compartment.
 - d. Ensure proper reassembly by marking blower wheel and motor in relation to blower housing before disassembly.
 - e. Loosen setscrew(s) that secures wheel to motor shaft, remove screws that secure motor mount brackets to housing, and slide motor and motor mount out of housing.
2. Remove and clean blower wheel as follows:
 - a. Ensure proper reassembly by marking wheel orientation.
 - b. Lift wheel from housing. When handling and/or cleaning blower wheel, be sure not to disturb balance weights (clips) on blower wheel vanes.
 - c. Remove caked-on dirt from wheel and housing with a brush. Remove lint and/or dirt accumulations from wheel and housing with vacuum cleaner, using soft brush attachment. Remove grease and oil with mild solvent.
 - d. Reassemble wheel into housing.
 - e. Reassemble motor into housing. Be sure setscrews are tightened on motor shaft flats and not on round part of shaft. Reinstall blower into unit.
 - f. Connect 5 pin plug and 4 pin plug to indoor blower motor. Reinstall capacitor if required.
 - g. Reinstall blower access panel (see Fig. 17).
3. Restore electrical power to unit. Start unit and check for proper blower rotation and motor speeds during cooling cycles.

50VG--A

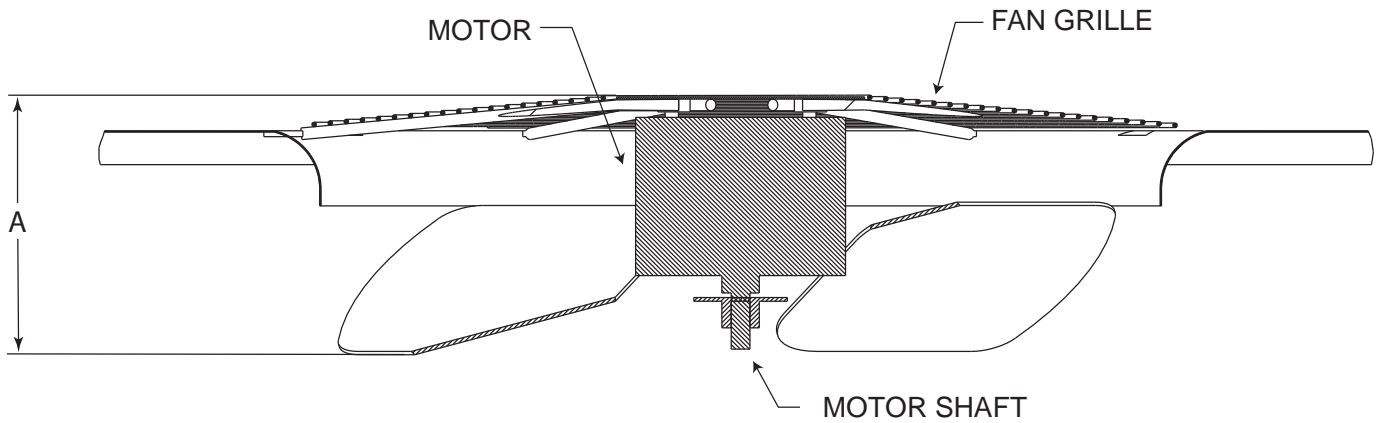

A08505

MAX DISTANCE BETWEEN TOP OF FAN GRILLE AND BOTTOM OF FAN BLADE

SIZE	"A"	
	IN.	MM
24	6.3	160
30	6.3	160
36	7.6	193
42	7.6	193
48	7.6	193
60	7.6	193

Fig. 16 - Fan Blade Position

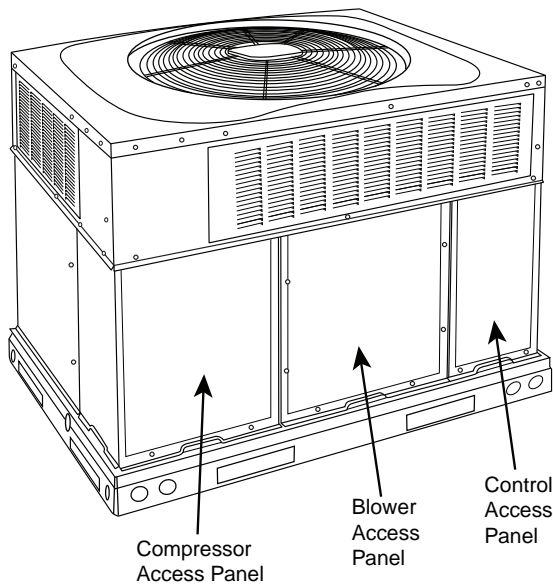

A09214

Fig. 17 - Unit Access Panels

Outdoor Coil, Indoor Coil, and Condensate Drain Pan

Inspect the condenser coil, evaporator coil, and condensate drain pan at least once each year.

The coils are easily cleaned when dry; therefore, inspect and clean the coils either before or after each cooling season. Remove all obstructions, including weeds and shrubs, that interfere with the airflow through the condenser coil.

Straighten bent fins with a fin comb. If coated with dirt or lint, clean the coils with a vacuum cleaner, using the soft brush attachment. Be careful not to bend the fins. If coated with oil or grease, clean the coils with a mild detergent and water solution. Rinse coils with clear water, using a garden hose. Be careful not to splash water on motors, insulation, wiring, or air filter(s). For best results, spray condenser coil fins from inside to outside the unit. On units with an outer and inner condenser coil, be sure to clean between the coils. Be sure to flush all dirt and debris from the unit base.

Inspect the drain pan and condensate drain line when inspecting the coils. Clean the drain pan and condensate drain by removing all foreign matter from the pan. Flush the pan and drain trough with clear water. Do not splash water on the insulation, motor, wiring, or air filter(s). If the drain trough is restricted, clear it with a "plumbers snake" or similar probe device.

OUTDOOR FAN

⚠ CAUTION

UNIT OPERATION HAZARD

Failure to follow this caution may result in damage to unit components.

Keep the condenser fan free from all obstructions to ensure proper cooling operation. Never place articles on top of the unit.

1. Remove 6 screws holding condenser grille and motor to top cover.
2. Turn motor/grille assembly upside down on top cover to expose the fan blade.
3. Inspect the fan blades for cracks or bends.
4. If fan needs to be removed, loosen the setscrew and slide the fan off the motor shaft.
5. When replacing fan blade, position blade as shown in Fig. 16.
6. Ensure that setscrew engages the flat area on the motor shaft when tightening
7. Replace grille.

Electrical Controls and Wiring

Inspect and check the electrical controls and wiring annually. Be sure to turn off the electrical power to the unit.

Remove access panels (see Fig. 17) to locate all the electrical controls and wiring. Check all electrical connections for tightness. Tighten all screw connections. If any smoky or burned connections are noticed, disassemble the connection, clean all the parts, restrip the wire end and reassemble the connection properly and securely.

50VG--A

After inspecting the electrical controls and wiring, replace the access panels (see Fig. 17). Start the unit, and observe at least one complete heating cycle and one complete cooling cycle to ensure proper operation. If discrepancies are observed in either or both operating cycles, or if a suspected malfunction has occurred, check each electrical component with the proper electrical instrumentation. Refer to the unit wiring label when making these checkouts.

NOTE: Refer to the heating and/or cooling sequence of operation in this publication as an aid in determining proper control operation

Refrigerant Circuit

Inspect all refrigerant tubing connections and the unit base for oil accumulations annually. Detecting oil generally indicates a refrigerant leak.

⚠ WARNING

EXPLOSION, SAFETY AND ENVIRONMENTAL HAZARD

Failure to follow this warning could result in personal injury, death or equipment damage.

This system uses Puron (R-410A) refrigerant which has higher operating pressures than R-22 and other refrigerants. No other refrigerant may be used in this system. Gauge set, hoses, and recovery system must be designed to handle Puron. If you are unsure, consult the equipment manufacturer.

If oil is detected or if low cooling performance is suspected, leak-test all refrigerant tubing using an electronic leak-detector, halide torch, or liquid-soap solution. If a refrigerant leak is detected, refer to Check for Refrigerant Leaks section.

If no refrigerant leaks are found and low cooling performance is suspected, refer to Checking and Adjusting Refrigerant Charge section.

Evaporator Airflow

The heating and/or cooling air-flow does not require checking unless improper performance is suspected. If a problem exists, be sure that all supply- and return-air grilles are open and free from obstructions, and that the air filter is clean. When necessary, refer to Indoor Airflow and Airflow Adjustments section to check the system airflow.

Puron Items

The indoor metering device is a TXV type device.

Pressure Switches

Pressure switches are protective devices wired into the control circuit (low voltage). They shut off compressor if abnormally high or low pressures are present in the refrigeration circuit. These pressure switches are specifically designed to operate with Puron (R-410A) systems. R-22 pressure switches must not be used as replacements for the Puron (R-410A) air conditioner.

Low-Pressure Switch (Air Conditioner Only)

This switch is located on the suction line and protects against low suction pressures caused by such events as loss of charge, low airflow across indoor coil, dirty filters, etc. It opens on a pressure drop at about 50 psig (957 Pa). If system pressure is above this, switch should be closed.

To check switch:

1. Turn off all power to unit.
2. Disconnect leads on switch.
3. Apply ohmmeter leads across switch. You should have continuity on a good switch.

NOTE: Because these switches are attached to refrigeration system under pressure, it is not advisable to remove this device for troubleshooting unless you are reasonably certain that a problem exists. If switch must be removed, remove and recover all system charge so that pressure gauges read 0 psi (0 Pa). Never open system without breaking vacuum with dry nitrogen.

High-Pressure Switch

The high-pressure switch is located in the discharge line and protects against excessive condenser coil pressure. It opens at 650 psig (31.1 kPa). High pressure may be caused by a dirty condenser coil, failed fan motor, or condenser air recirculation.

To check switch:

1. Turn off all power to unit.
2. Disconnect leads on switch.
3. Apply ohmmeter leads across switch. You should have continuity on a good switch.

Copeland Scroll Compressor (Puron Refrigerant)

The compressor used in this product is specifically designed to operate with Puron (R-410A) refrigerant and cannot be interchanged.

The compressor is an electrical (as well as mechanical) device. Exercise extreme caution when working near compressors. Power should be shut off, if possible, for most troubleshooting techniques. Refrigerants present additional safety hazards.

⚠ WARNING

FIRE/EXPLOSION HAZARD

Failure to follow this warning could result in personal injury or death and/or property damage.

Wear safety glasses and gloves when handling refrigerants. Keep torches and other ignition sources away from refrigerants and oils.

The scroll compressor pumps refrigerant throughout the system by the interaction of a stationary and an orbiting scroll. The scroll compressor has no dynamic suction or discharge valves, and it is more tolerant of stresses caused by debris, liquid slugging, and flooded starts. The compressor is equipped with a noise reducing shutdown device and an internal pressure relief port. The pressure relief port is a safety device, designed to protect against extreme high pressure. The relief port has an operating range between 550 (26.3 kPa) and 625 (29.9 kPa) psig differential pressure.

Refrigerant

⚠ WARNING

EXPLOSION, ENVIRONMENTAL HAZARD

Failure to follow this warning could result in personal injury, death or equipment damage.

This system uses Puron (R-410A) refrigerant which has higher operating pressures than R-22 and other refrigerants. No other refrigerant may be used in this system. Gauge set, hoses, and recovery system must be designed to handle Puron. If you are unsure, consult the equipment manufacturer.

This system uses Puron (R-410A) refrigerant which has higher operating pressures than R-22 and other refrigerants. No other refrigerant may be used in this system. Gauge set, hoses, and recovery system must be designed to handle Puron. If you are unsure, consult the equipment manufacturer. Failure to use Puron compatible servicing equipment or replacement components may result in property damage or injury.

50VG--A

Compressor Oil

The Copeland scroll compressor uses 3MAF POE oil. If additional oil is needed, use Uniqema RL32-3MAF. If this oil is not available, use Copeland Ultra 32 CC or Mobil Arctic EAL22 CC. This oil is extremely hygroscopic, meaning it absorbs water readily. POE oils can absorb 15 times as much water as other oils designed for HCFC and CFC refrigerants. Take all necessary precautions to avoid exposure of the oil to the atmosphere.

Servicing Systems on Roofs with Synthetic Materials

POE (polyolester) compressor lubricants are known to cause long term damage to some synthetic roofing materials. Exposure, even if immediately cleaned up, may cause embrittlement (leading to cracking) to occur in one year or more. When performing any service that may risk exposure of compressor oil to the roof, take appropriate precautions to protect roofing. Procedures which risk oil leakage include, but are not limited to, compressor replacement, repairing refrigerant leaks, replacing refrigerant components such as filter drier, pressure switch, metering device, coil, accumulator, or reversing valve.

Synthetic Roof Precautionary Procedure

1. Cover extended roof working area with an impermeable polyethylene (plastic) drip cloth or tarp. Cover an approximate 10 x 10 ft (3 x 3 m) area.
2. Cover area in front of the unit service panel with a terry cloth shop towel to absorb lubricant spills, prevent run-offs, and protect drop cloth from tears caused by tools or components.
3. Place terry cloth shop towel inside unit immediately under component(s) to be serviced and prevent lubricant run-offs through the louvered openings in the unit base.
4. Perform required service.
5. Remove and dispose of any oil contaminated material per local codes.

Liquid Line Filter Drier

The filter drier is specifically designed to operate with Puron. Use only factory-authorized components. Filter drier must be replaced whenever the refrigerant system is opened. When removing a filter drier, use a tubing cutter to cut the drier from the system. Do not unsweat a filter drier from the system. Heat from unsweating will release moisture and contaminants from drier into system.

Puron (R-410A) Refrigerant Charging

Refer to unit information plate and charging chart. Some R-410A refrigerant cylinders contain a dip tube to allow liquid refrigerant to flow from cylinder in upright position. For cylinders equipped with a dip tube, charge Puron units with cylinder in upright position and a commercial metering device in manifold hose. Charge refrigerant into suction-line.

TROUBLESHOOTING

Refer to the Troubleshooting Chart (Table 10) for troubleshooting information.

START-UP CHECKLIST

Use the Start-Up Checklist at the back of this manual.

Table 10 – Troubleshooting Chart

SYMPTOM	CAUSE	REMEDY
Compressor and outdoor fan will not start	Power failure	Call power company
	Fuse blown or circuit breaker tripped	Replace fuse or reset circuit breaker
	Defective contactor, transformer or high-pressure, loss-of-charge or low-pressure switch	Replace component
	Insufficient line voltage	Determine cause and correct
	Incorrect or faulty wiring	Check wiring diagram and rewire correctly
	Thermostat setting too high	Lower thermostat setting below room temperature
Compressor will not start but condenser fan runs	Faulty wiring or loose connections in compressor circuit	Check wiring and repair or replace
	Compressor motor burned out, seized, or internal overload open	Determine cause Replace compressor
	Defective run/start capacitor, overload, start relay	Determine cause and replace
Three-phase scroll compressor (size 30-60 unit) has a low pressure differential	Scroll compressor is rotating in the wrong direction	Correct the direction of rotation by reversing the 3-phase power leads to the unit
Compressor cycles (other than normally satisfying thermostat)	Refrigerant overcharge or undercharge	Recover refrigerant, evacuate system, and recharge to capacities shown on rating plate
	Defective compressor	Replace and determine cause
	Insufficient line voltage	Determine cause and correct
	Blocked condenser	Determine cause and correct
	Defective run/start capacitor, overload or start relay	Determine cause and replace
	Defective thermostat	Replace thermostat
	Faulty condenser-fan motor or capacitor	Replace
	Restriction in refrigerant system	Locate restriction and remove
Compressor operates continuously	Dirty air filter	Replace filter
	Unit undersized for load	Decrease load or increase unit size
	Thermostat set too low	Reset thermostat
	Low refrigerant charge	Locate leak, repair, and recharge
	Mechanical damage in compressor	Replace compressor
	Air in system	Recover refrigerant, evacuate system, and recharge
	Condenser coil dirty or restricted	Clean coil or remove restriction
Excessive head pressure	Dirty air filter	Replace filter
	Dirty indoor or outdoor coil	Clean coil
	Refrigerant overcharged	Recover excess refrigerant
	Air in system	Recover refrigerant, evacuate system, and recharge
Head pressure too low	Low refrigerant charge	Check for leaks, repair and recharge
	Compressor IPR leaking	Replace compressor
	Restriction in liquid tube	Remove restriction
Excessive suction pressure	High heat load	Check for source and eliminate
	Compressor IPR leaking	Replace compressor
	Refrigerant overcharged	Recover excess refrigerant
Suction pressure too low	Dirty air filter	Replace filter
	Low refrigerant charge	Check for leaks, repair and recharge
	Metering device or low side restricted	Remove source of restriction
	Insufficient evaporator airflow	Increase air quantity Check filter—replace if necessary
	Temperature too low in conditioned area	Reset thermostat
	Outdoor ambient below 55°F (12.7°C)	Install low-ambient kit
	Filter drier restricted	Replace filter

50VG--A

AIR CONDITIONER WITH PURON (R-410A) QUICK REFERENCE GUIDE

Puron refrigerant operates at 50–70 percent higher pressures than R-22. Be sure that servicing equipment and replacement components are designed to operate with Puron. Puron refrigerant cylinders are rose colored.

- Puron refrigerant cylinders manufactured prior to March 1, 1999, have a dip tube that allows liquid to flow out of cylinder in upright position.
Cylinders manufactured March 1, 1999 and later DO NOT have a dip tube and MUST be positioned upside down to allow liquid to flow.
- Recovery cylinder service pressure rating must be 400 psig. DOT 4BA400 or DOT BW400.
- Puron systems should be charged with liquid refrigerant. Use a commercial type metering device in the manifold hose.
- Manifold sets should be minimum 700 psig high-side and 180 psig low-side with 550 psig low-side retard.
- Use hoses with minimum 700 psig service pressure rating.
- Leak detectors should be designed to detect HFC refrigerant.
- Puron, as with other HFCs, is only compatible with POE oils.
- Vacuum pumps will not remove moisture from oil.
- Only use factory specified liquid-line filter driers with rated working pressures no less than 600 psig.
- Do not install a suction-line filter drier in liquid line.
- POE oils absorb moisture rapidly. Do not expose oil to atmosphere.
- POE oils may cause damage to certain plastics and roofing materials.
- Wrap all filter driers and service valves with wet cloth when brazing.
- A Puron liquid-line filter drier is required on every unit.
- Do not use an R-22 TXV.
- Never open system to atmosphere while it is under a vacuum.
- When system must be opened for service, break vacuum with dry nitrogen and replace filter driers.
- Always replace filter drier after opening system for service.
- Do not vent Puron into the atmosphere.
- Observe all warnings, cautions, and bold text.
- Do not leave Puron suction line driers in place for more than 72 hrs.

START-UP CHECKLIST

(Remove and Store in Job Files)

I. PRELIMINARY INFORMATION

MODEL NO.: _____

SERIAL NO.: _____

DATE: _____

TECHNICIAN: _____

II. PRESTART-UP (Insert check mark in box as each item is completed)

- () VERIFY THAT ALL PACKING MATERIALS HAVE BEEN REMOVED FROM UNIT
- () REMOVE ALL SHIPPING HOLD DOWN BOLTS AND BRACKETS PER INSTALLATION INSTRUCTIONS
- () CHECK ALL ELECTRICAL CONNECTIONS AND TERMINALS FOR TIGHTNESS
- () CHECK THAT INDOOR (EVAPORATOR) AIR FILTER IS CLEAN AND IN PLACE
- () VERIFY THAT UNIT INSTALLATION IS LEVEL
- () CHECK FAN WHEEL, AND PROPELLER FOR LOCATION IN HOUSING/ORIFICE AND SETSCREW TIGHTNESS

III. START-UP

ELECTRICAL

SUPPLY VOLTAGE _____

COMPRESSOR AMPS _____

INDOOR (EVAPORATOR) FAN AMPS _____

TEMPERATURES

OUTDOOR (CONDENSER) AIR TEMPERATURE _____ DB

RETURN-AIR TEMPERATURE _____ DB _____ WB

COOLING SUPPLY AIR _____ DB _____ WB

PRESSURES

REFRIGERANT SUCTION _____ PSIG, SUCTION LINE TEMP* _____

REFRIGERANT DISCHARGE _____ PSIG, LIQUID TEMP† _____

- () VERIFY REFRIGERANT CHARGE USING CHARGING CHARTS

* Measured at suction inlet to compressor

† Measured at liquid line leaving condenser.

50VG--A

