



# 48/50LC, 48/50A, 48/50P, 48/50N, 48/50Z Humidity Sensor for Enthalpy Control Accessory

## Installation Instructions

Part Number CRHUMDSN001B00

The accessory humidity sensor can be used with all 48/50LC SystemVu unit economizers that have a dry bulb temperature sensor but enthalpy control is desired. The accessory sensor can also be added to a SystemVu enthalpy economizer to provide differential enthalpy.

The accessory humidity sensor can be used with all 48/50A, 48/50N, 48/50P, and 48/50Z units with *ComfortLink* controls.

### PACKAGE USAGE

| UNIT                         | SIZE        |
|------------------------------|-------------|
| 48/50AJ,AK,AW,AY,A2,A3,A4,A5 | 020-060     |
| 48/50LC                      | 07-26       |
| 48/50N2,N3,N4,N5,N6,N7,N8,N9 | 75-150 tons |
| 48/50P2,P3,P4,P5             | 030-100     |
| 48/50Z                       | 030-105     |

### PACKAGE CONTENTS

| ITEM                                 | QUANTITY |
|--------------------------------------|----------|
| Humidity Sensor                      | 1        |
| 6-20, 3/4-in. long Sheet Metal Screw | 2        |
| Wiring Harness, 42-in., 2 Pin*       | 1        |

\*Wiring harness included in this package is not used on 48/50A, 48/50P, 48/50N or 48/50Z units or SystemVu economizers.

### GENERAL

The humidity sensor (see Fig. 1) measures the amount of moisture in the air. It is used in conjunction with a temperature sensor to determine the enthalpy content of the air. The temperature sensor is provided as a standard feature with all units listed. The humidity sensor sends a 4 to 20 mA signal to the controller.

**IMPORTANT:** For horizontal applications, it is easiest to install the humidity sensor prior to making duct connections.

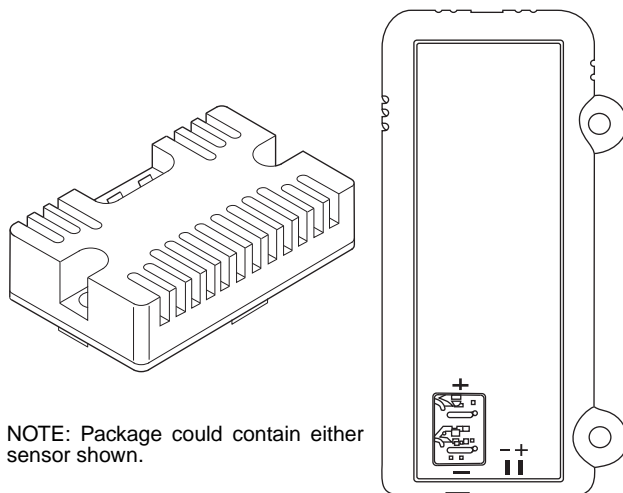

NOTE: Package could contain either sensor shown.

**Fig. 1 — Humidity Sensor**

### SAFETY CONSIDERATIONS

Installation of this accessory can be hazardous due to system pressures, electrical components, and equipment location (such as a roof or elevated structure).

Only trained, qualified installers and service technicians should install, start up, and service this equipment.

When installing this accessory, observe precautions in the literature, labels attached to the equipment, and any other safety precautions that apply.

- Follow all safety codes.
- Wear safety glasses and work gloves.
- Use care in handling and installing this accessory.

#### ⚠ WARNING

Prior to installation of this accessory, make sure all power is disconnected to the unit and locked out. Failure to disconnect power supply prior to servicing may result in serious injury.

#### ⚠ CAUTION

When removing panels from the unit, be careful not to damage the roof or other surfaces with the panels.

### 48/50LC SERIES INSTALLATION

**Installation for Adding Humidity Sensor to Outside Air (48/50LC Units Only)** — This accessory kit can be installed on many different types of SystemVu economizers, including small and medium rooftop sizes, and vertical or horizontal applications. This humidity sensor when used in conjunction with the factory-supplied dry bulb sensor, will provide enthalpy control. The figures are not intended to show illustrations for all economizers, but the general instructions are the same for all.

1. Remove the 42 in. wiring harness that is connected to the humidity sensor. It will not be used with SystemVu economizer.
2. In some cases it may be necessary to remove the aluminum filter in the hood to install the humidity sensor. Install the humidity sensor in the outdoor air stream as shown in Fig. 2. Screw the sensor in place. Make sure the sensor does not interfere with the hood.
3. Units with SystemVu controls have a PINK and GRAY wire routed close to (but not in) the PL6 economizer harness in the economizer section. These (2) wires are to be connected to the sensor. Connect the PINK wire to the + terminal and the GRAY wire to the - terminal. See Fig. 3.
4. If removed, reinstall the economizer aluminum filters in the hood.
5. Configure the SystemVu controls for use with the humidity sensor. Refer to the unit Controls and Troubleshooting literature for more information.

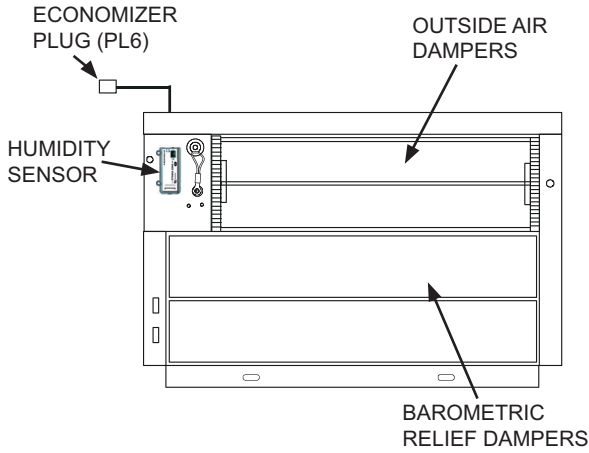

**Fig. 2 — Humidity Sensor Location for 48/50LC**

**Installation for Adding Humidity Sensor for Return Air (Differential) (48/50LC Units Only)**

This accessory kit can also be used to add a second humidity sensor to a SystemVu economizer. This second humidity sensor would be used for a return air (or differential) sensor, where the outside air enthalpy is compared to the return air enthalpy, and the most favorable air is used for free-cooling. To add a return air (differential) sensor, first the outside air must be controlled by a dry bulb and a humidity (enthalpy) sensor. This return air humidity sensor will be used in conjunction with the factory-installed dry bulb temperature sensor to provide differential enthalpy control.

1. Remove the 42-in. wiring harness that is connected to the humidity sensor. It will not be used with SystemVu economizer.
2. If possible, install the return air humidity sensor in the return duct before the HVAC unit is set, which would make

installation easier. Install the return air humidity sensor in the return air duct, as shown in Fig. 4.

NOTE: This illustration is generic and to be used for a general guide only. Screw the sensor in place.

3. Route the (2) PNK wires from the SystemVu control board to the return air (RA) humidity sensor. Wire the return air humidity sensor to the SystemVu control board by connecting (2) PNK wires as shown in Fig. 3.

NOTE: The pink wire connected to J7 pin 5 is 24vdc and should be connected on the + terminal.

4. Configure the SystemVu controls for use with the humidity sensor. Refer to the unit Controls and Troubleshooting literature for more information.

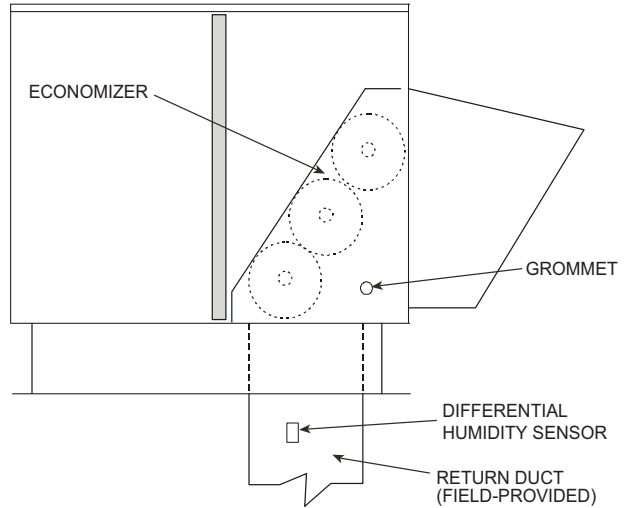

**Fig. 4 — Return Air (Differential) Humidity Sensor Location for 48/50LC**

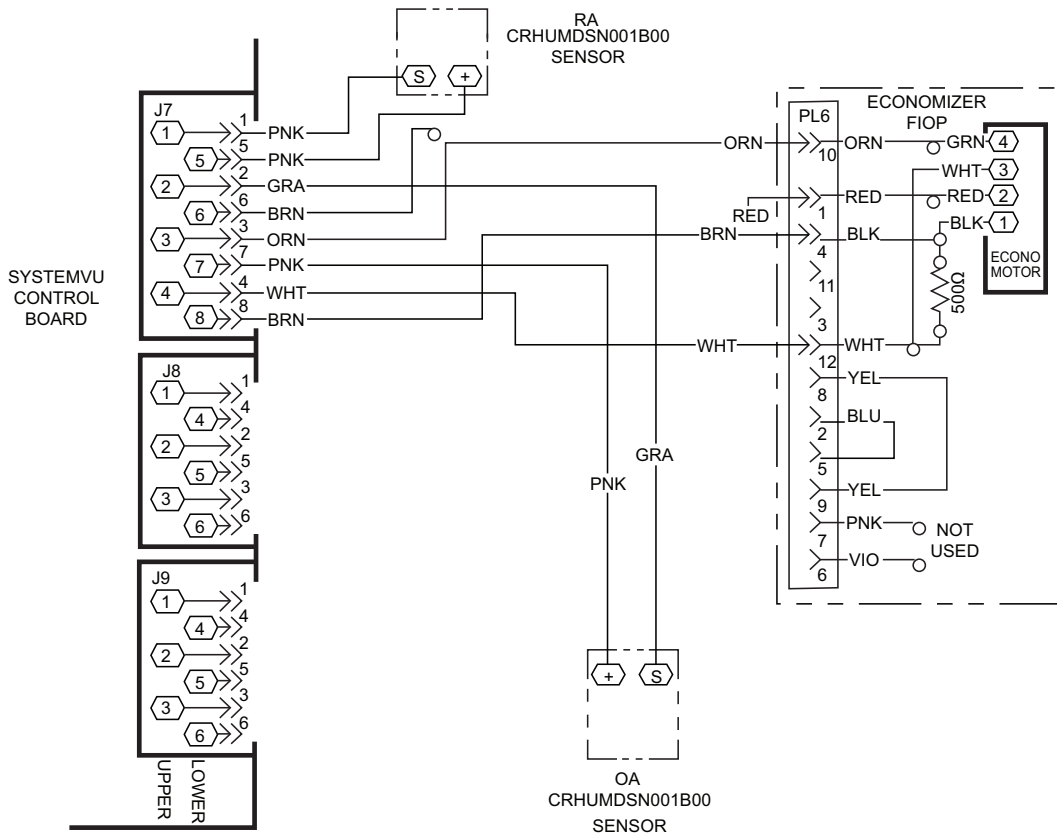

**Fig. 3 — SystemVu Wiring Diagram for 48/50LC**

## 48/50A, 48/50N, 48/50P and 48/50Z SERIES INSTALLATION

On all units, the outdoor air temperature sensor and the return air temperature sensor are standard.

**48/50A Series** — For single enthalpy control, an accessory humidity sensor (P/N CRHUMDSN001B00) is required. Two accessory humidity sensors (P/N CRHUMDSN001B00) are required for differential enthalpy control.

**48/50N, 48/50P and 48/50Z Series** — For single enthalpy control the 48/50N, P, and Z Series are equipped with an enthalpy switch as standard equipment. If single enthalpy control with a configurable enthalpy set point is desired, an accessory humidity sensor (P/N CRHUMDSN001B00) is required. Two accessory humidity sensors (P/N CRHUMDSN001B00) are required for differential enthalpy control.

### 48/50A Series Units

#### OUTDOOR AIR HUMIDITY SENSOR

1. Remove the wiring harness that is connected to the humidity sensor.

NOTE: The 42-in. wiring harness is not used.

2. Install the outdoor air humidity sensor on the economizer using the screws provided (see Fig. 5). Attachment holes are pre-punched.
3. Electrical connections are made to an existing harness that is factory-routed to the sensor mounting location. Connect outdoor air humidity sensor to the harness plug labeled OARH. The harness is factory-wired to the economizer control board (ECB1), terminals J5-4 (BLU) and J5-5 (ORN).
4. Configure the *ComfortLink* controls for use with the humidity sensor. Refer to the unit Controls and Troubleshooting literature for more information.

#### RETURN AIR HUMIDITY SENSOR

1. Remove the wiring harness that is connected to the humidity sensor.

NOTE: The 42-in. wiring harness is not used.

2. Install the return air humidity sensor on the economizer using the screws provided (see Fig. 5). Attachment holes are pre-punched.
3. Electrical connections are made to an existing harness that is factory-routed to the sensor mounting location. Connect return air humidity sensor to the harness plug

labeled RARH. The harness is factory-wired to the economizer control board (ECB1), terminals J5-1 (BLU) and J5-2 (ORN).

4. Configure the *ComfortLink* controls for use with the humidity sensor. Refer to the unit Controls and Troubleshooting literature for more information.

### 48/50P and 48/50Z Series Units

#### OUTDOOR AIR HUMIDITY SENSOR

1. Remove the wiring harness that is connected to the humidity sensor. This wiring harness is not used.
2. Remove the economizer side hood and filters to gain access to the location where the humidity sensor will be mounted. See Fig. 6.
3. Install the humidity sensor using the screws provided. See Fig. 6. Attachment holes are pre-punched.
4. Electrical connections are made to an existing harness that is factory-routed to the sensor mounting location. Find the pair of wires labeled OARH. Connect the red wire to the “+” terminal of the humidity sensor. Connect the black wire to the “-” terminal of the sensor.
5. Configure the *ComfortLink* controls for use with the humidity sensor. Refer to the unit Controls and Troubleshooting literature for details.
6. Reinstall the filters and hood.

#### RETURN AIR HUMIDITY SENSOR

1. Remove the wiring harness that is connected to the humidity sensor. This wiring harness is not used.
2. Open the power exhaust section door/panel to gain access to the location where the humidity sensor will be mounted. See Fig. 7.
3. Install the humidity sensor using the screws provided. See Fig. 7. Attachment holes are pre-punched.
4. Electrical connections are made to an existing harness that is factory-routed to the sensor mounting location. Find the pair of wires labeled RARH. Connect the blue wire to the “+” terminal of the humidity sensor. Connect the violet wire to the “-” terminal of the sensor.
5. Configure the *ComfortLink* controls for use with the humidity sensor. Refer to the unit Controls and Troubleshooting literature for details.
6. Close and secure all doors and panels.

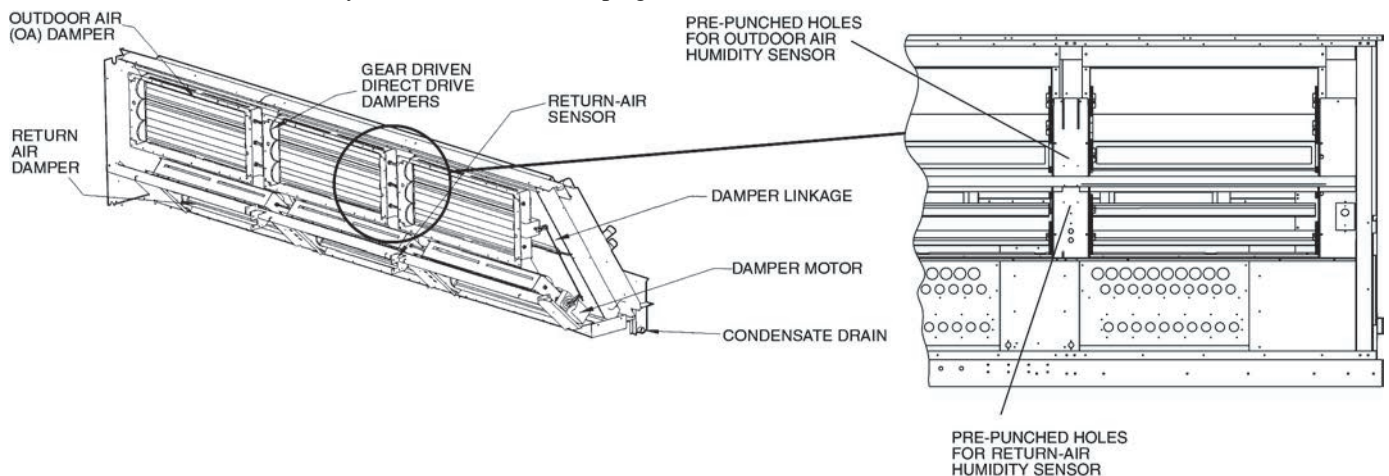
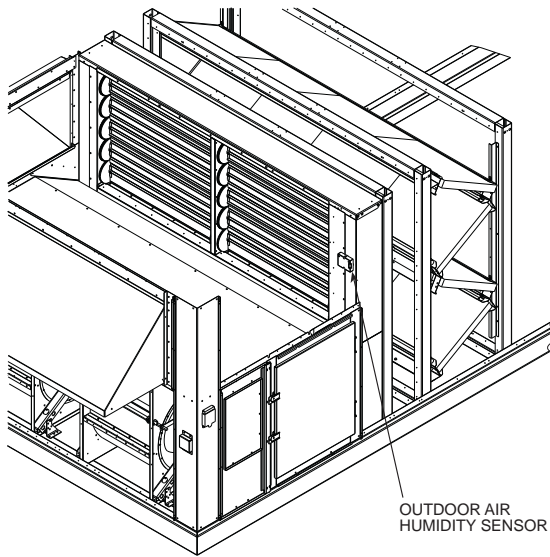
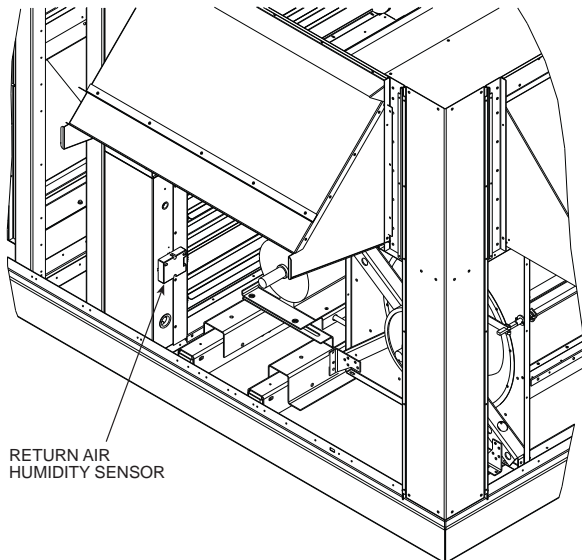

Fig. 5 — Typical Outdoor and Return Air Humidity Sensor Locations for 48/50A Series Units



**Fig. 6 — Typical Outdoor Air Humidity Sensor Location for 48/50P and 48/50Z Series Units**



**Fig. 7 — Typical Return Air Humidity Sensor Location for 48/500P and 48/50Z Series Units**

## RETURN AIR HUMIDITY SENSOR

1. Remove the wiring harness that is connected to the humidity sensor. This wiring harness is not used.
2. Open the power exhaust section door/panel to gain access to the location where the humidity sensor will be mounted. See Fig. 9.
3. Install the humidity sensor using the screws provided. See Fig. 9. Attachment holes are pre-punched.
4. Electrical connections are made to an existing harness that is factory-routed to the sensor mounting location. Find the pair of wires labeled RARH. Connect the blue wire to the “+” terminal of the humidity sensor. Connect the violet wire to the “-” terminal of the sensor.
5. Configure the *ComfortLink* controls for use with the humidity sensor. Refer to the unit Controls and Troubleshooting literature for details.
6. Close and secure all doors and panels.

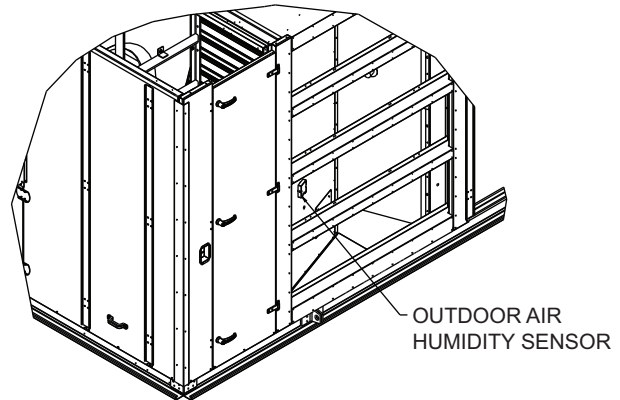

**Fig. 8 — Outdoor Air Humidity Sensor Location for 48/50N Series Units**

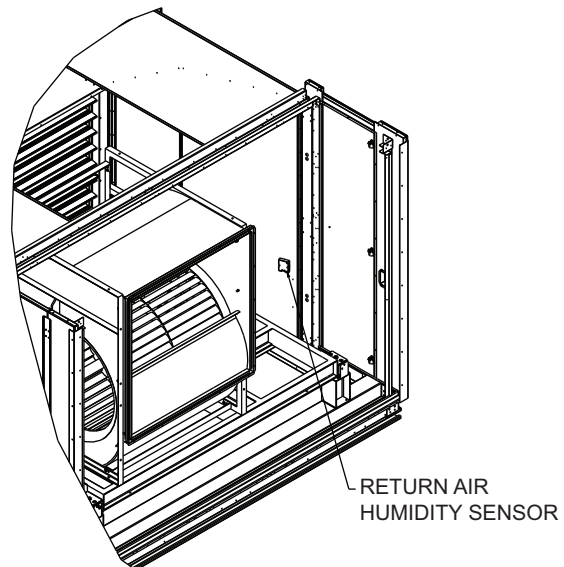

**Fig. 9 — Return Air Humidity Sensor Location for 48/50N Series Units**

## 48/50N Series Units

### OUTDOOR AIR HUMIDITY SENSOR

1. Remove the wiring harness that is connected to the humidity sensor. This wiring harness is not used.
2. Remove the economizer side hood and filters to gain access to the location where the humidity sensor will be mounted. See Fig. 8.
3. Install the humidity sensor using the screws provided. See Fig. 8. Attachment holes are pre-punched.
4. Electrical connections are made to an existing harness that is factory-routed to the sensor mounting location. Find the pair of wires labeled OARH. Connect the red wire to the “+” terminal of the humidity sensor. Connect the black wire to the “-” terminal of the sensor.
5. Configure the *ComfortLink* controls for use with the humidity sensor. Refer to the unit Controls and Troubleshooting literature for details.
6. Reinstall the filters and hood.