

Packaged Air-Handling Units 6 to 30 Tons Subbase Accessory

Cancels: New

IIK 524A-72-1
3/15/95

Installation Instructions

Part Nos. CASUBASE001A00 – CASUBASE004A00

SAFETY CONSIDERATIONS

Installation of this accessory can be hazardous due to electrical components and equipment location (such as a ceiling or elevated structure). Only trained, qualified installers and service mechanics should install and service this equipment.

When installing this accessory, observe precautions in the literature, labels attached to the equipment, and any other safety precautions that apply.

- Follow all safety codes.
- Wear safety glasses and work gloves.
- Use care in handling and installing this accessory.



ELECTRIC SHOCK HAZARD

To avoid the possibility of electrical shock, open and tag all disconnects before installing this equipment.

INTRODUCTION

The subbase accessory (Fig. 1) provides a stable, raised platform for 6 to 30 ton packaged air-handling units. The accessory is recommended for all vertical installations to enable condensate trap construction. See Table 1 for usage by unit size.

Table 1 – Accessory Usage

UNIT	ACCESSORY KIT PART NO.
6 to 20 Ton Direct-Expansion Units	CASUBASE001A00 (Unpainted)
7½ to 20 Ton Chilled Water Units	CASUBASE003A00 (Painted)
25 and 30 Ton Direct-Expansion and Chilled Water Units	CASUBASE002A00 (Unpainted) CASUBASE004A00 (Painted)

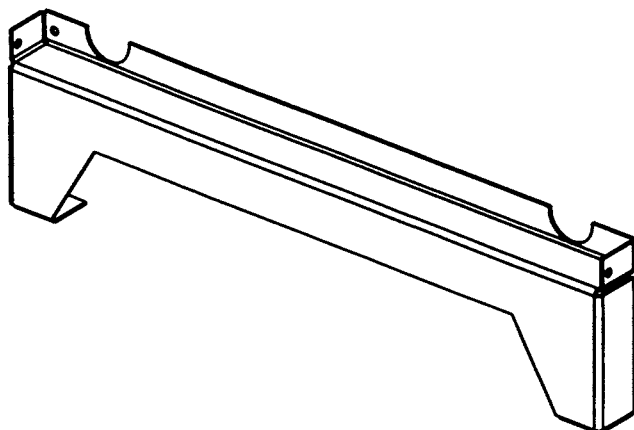

Fig. 1 – Subbase (2 Supplied per Accessory Kit)

Copyright 1995 Carrier Corporation

INSTALLATION

Refer to Fig. 2 while performing the following steps:

1. Raise and support one end of the unit higher than the subbase leg height of 6 in. (152 mm).
2. Remove the 2 screws from each of the 2 raised bottom corners of the unit.
3. Place a subbase leg in position on the raised end of the unit. Align the leg mounting holes with the holes in the unit base.
4. Using the screws removed in Step 1, fasten the leg to the bottom of the unit. Tighten all screws and lower the unit onto the subbase leg.
5. Repeat Steps 1-4 for the second leg on the opposite side of the unit.
6. Install the unit according to the base unit Installation, Start-Up and Service instructions.

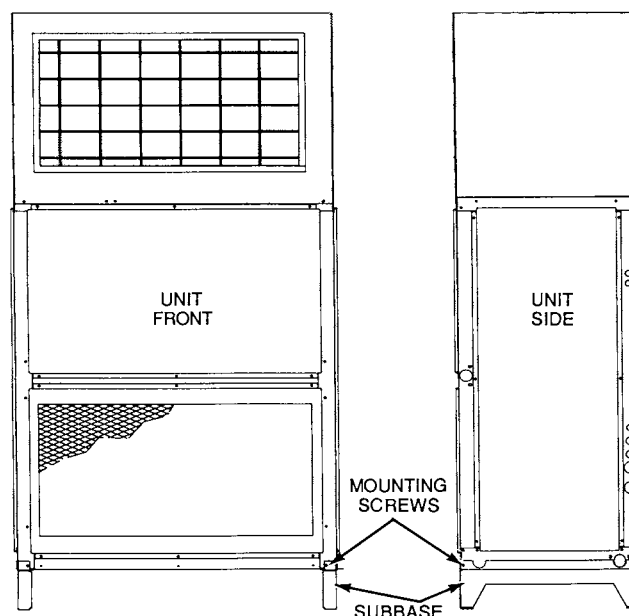

Fig. 2 – Subbase Installation

Manufacturer reserves the right to discontinue, or change at any time, specifications or designs without notice and without incurring obligations.