

# Installation Instructions

Part Nos. CAECOMZR001A00 - CAECOMZR006A00

## CONTENTS

<b>SAFETY CONSIDERATIONS</b> .....	1
<b>INTRODUCTION</b> .....	1
<b>PREINSTALLATION</b> .....	1,2
<b>Complete Preinstallation Checks</b> .....	1
<b>Check Unit Clearance</b> .....	1
<b>INSTALLATION</b> .....	3-10
<b>Mount Economizer on Unit</b> .....	3
<b>Install Transformer, Relay, and   Supply-Air Temperature Sensor</b> .....	4
<b>Install Economizer, SAT Sensor, Relay,   and Transformer Wiring</b> .....	4
<b>Applications Using a Single Enthalpy   Sensor: Installing Enthalpy Sensor and   Connecting Ductwork</b> .....	8
<b>Applications Using Differential Enthalpy Sensors:   Installing Enthalpy Sensors and Connecting   Ductwork</b> .....	8
<b>Adjust Enthalpy Setting and Minimum Damper   Position</b> .....	9
<b>Using a CO<sub>2</sub> Sensor with the Economizer</b> .....	9
<b>SEQUENCE OF OPERATION —   AIR HANDLER WITH ECONOMIZER</b> .....	11
<b>START-UP</b> .....	11

capacity by size and see Table 2 for accessory weight and kit contents.

A separate CO<sub>2</sub> sensor accessory is available for use with the economizer. The sensor signals the economizer to admit outdoor air to the occupied space to dilute the carbon dioxide level when it exceeds the set point. The sensor has an adjustable range of 0 to 2000 ppm.

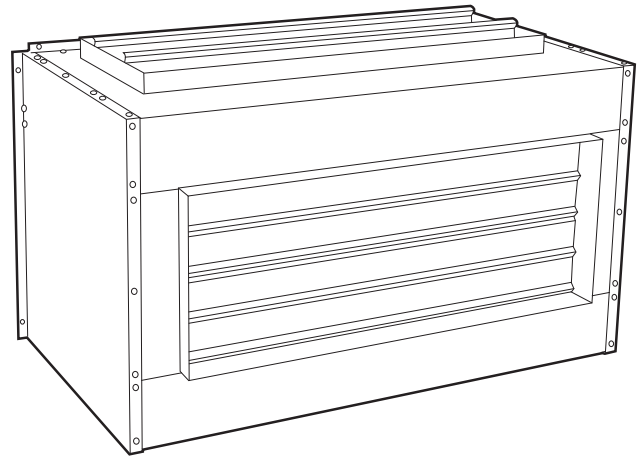

**Fig. 1 — Economizer Accessory**

## SAFETY CONSIDERATIONS

Installation of this accessory can be hazardous due to electrical components and equipment location (such as a ceiling or elevated structure). Only trained, qualified installers and service mechanics should install and service this equipment.

When installing this accessory, observe precautions in the literature, labels attached to the equipment, and any other safety precautions that apply.

- Follow all safety codes.
- Wear safety glasses and work gloves.
- Use care in handling and installing this accessory.

	<b>ELECTRIC SHOCK HAZARD</b> To avoid the possibility of electrical shock, open and tag all disconnects before installing this equipment.
--	--

## INTRODUCTION

The economizer accessory (Fig. 1) allows outside air to be mixed with return air for “free” cooling if the outdoor-air temperature and humidity are suitable. Economizer cooling can be used alone or in conjunction with mechanical cooling. The economizer can also be used to provide ventilation air to improve indoor air quality. An enthalpy control is provided with the economizer accessory. Refer to Table 1 to determine unit

## PREINSTALLATION

**Complete Preinstallation Checks** — Remove accessory packaging and inspect shipment for damage. File claim with shipping company if accessory is damaged or incomplete.

**Check Unit Clearance** — Provide sufficient space for air-flow clearance, wiring, and servicing accessory after it is mounted on unit. See Fig. 2 for accessory dimensions. Base unit service clearances of 2.5 ft from front and sides of unit and 3 in. from rear of unit also apply to the economizer.

**Table 1 — Unit Model Size to Nominal Tons**

UNIT MODEL SIZE	NOMINAL TONS
<b>07 or 072</b>	6
<b>08 or 091</b>	7.5
<b>10</b>	8.5
<b>12 or 120</b>	10
<b>14 or 150</b>	12.5
<b>16 or 180</b>	15
<b>25 or 240</b>	20
<b>28</b>	25
<b>30</b>	30

NOTE: Field connections figures apply to units with Puron® refrigerant (R-410A) built in 2009 or later. Refer to earlier economizer installation instructions for information on R-22 units.

**Table 2 — Accessory Usage and Weight**

UNIT	ECONOMIZER ACCESSORY KIT NO.	WEIGHT — lb (kg)	KIT CONTENTS
Direct-Expansion Units, 6 to 10 Tons	CAECOMZR001A00 (Unpainted)	185 (84.1)	1 — Economizer Assembly 1 — Transformer 1 — Enthalpy Sensor (with mounting screws) 1 — Supply-Air Temperature Sensor 1 — Relay (Pilot Duty) 4 — No. 10 x 1/2 in. Self-Tapping Screws 4 — No. 8 x 1/2 in. Sheet Metal Screws 4 — P-Clamps
	CAECOMZR004A00 (Painted)		
Direct-Expansion and Chilled Water Units, 12 1/2 to 20 Tons	CAECOMZR002A00 (Unpainted)	340 (154.5)	
	CAECOMZR005A00 (Painted)		
Direct-Expansion and Chilled Water Units, 25 and 30 Tons	CAECOMZR003A00 (Unpainted)	450 (204.5)	
	CAECOMZR006A00 (Painted)		

**6 TO 10 TON UNITS**

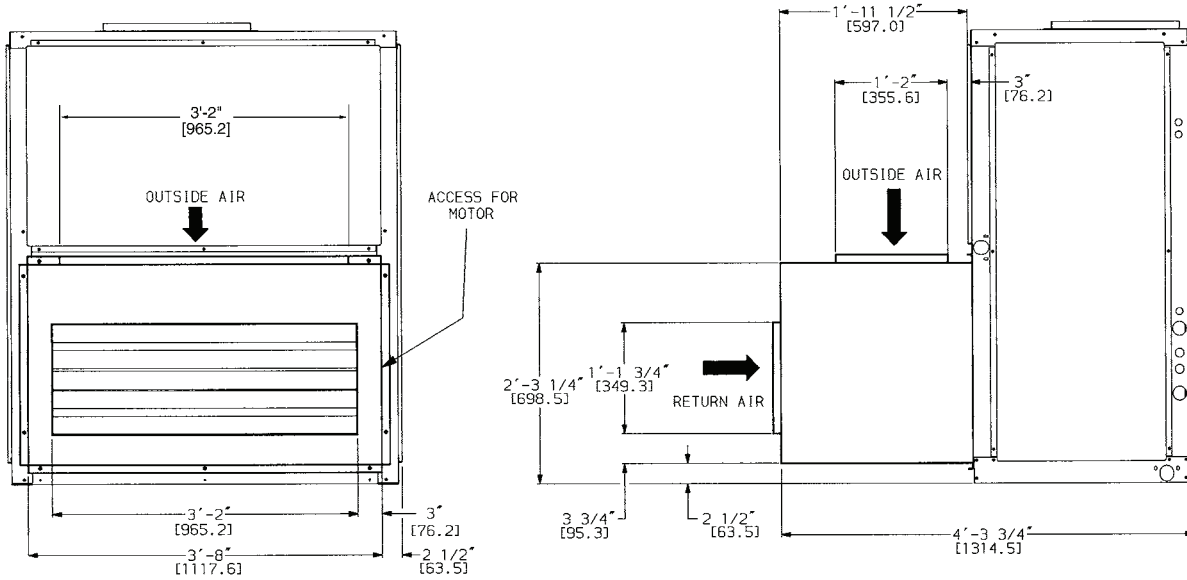

**12 1/2 TO 20 TON UNITS**

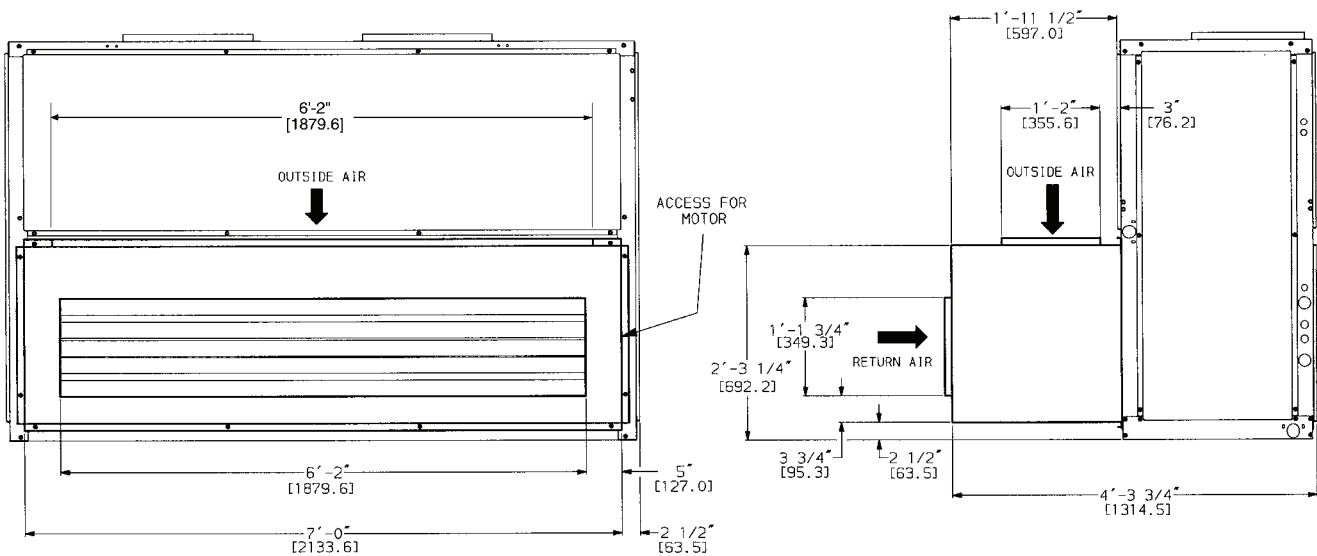

NOTE: Dimensions in [ ] are millimeters.

**Fig. 2 — Economizer Mounted on Unit (Vertical Installation Shown)**

25 AND 30 TON UNITS

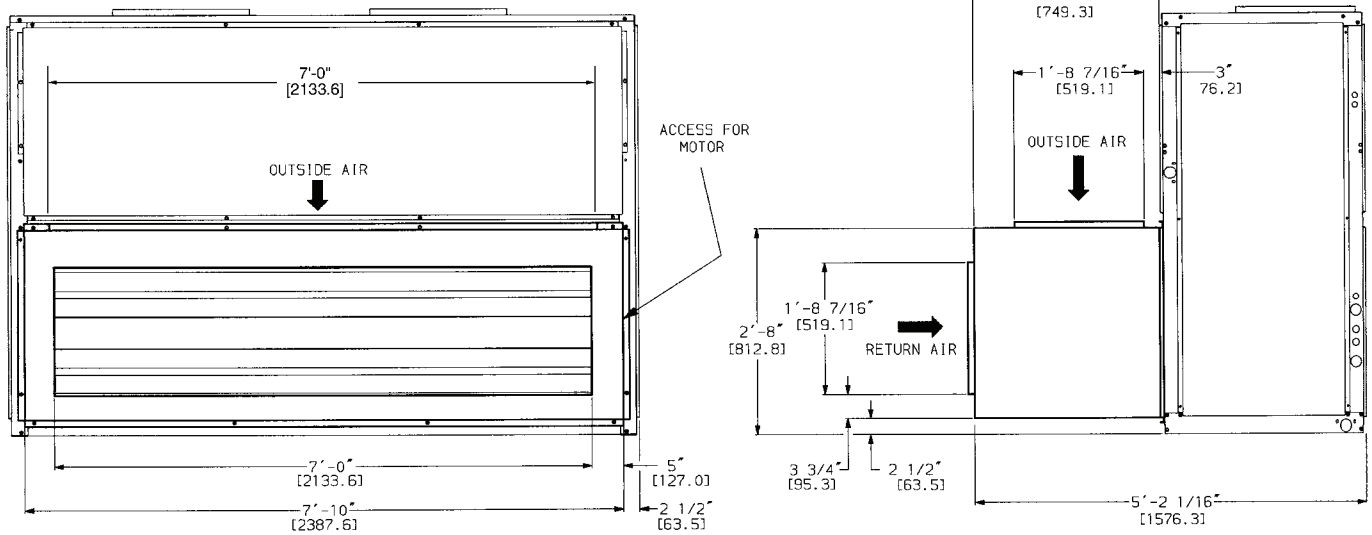

NOTE: Dimensions in [ ] are millimeters.

Fig. 2 — Economizer Mounted on Unit (Vertical Installation Shown) (cont)

**INSTALLATION**

**Mount Economizer on Unit** — Refer to Fig. 3 and 4 and perform the following steps:

1. Orient the unit so that the desired return-air opening is accessible. For vertical installations, reposition the panel from the rear to the bottom of the unit using the same screws.

2. Remove the bag containing loose parts and fasteners from inside the economizer. These parts will be used later.
3. Install field-supplied gasket material over economizer flanges.
4. Place the economizer and gasket over the return-air opening so that the flanges and screw holes on the top and bottom of the economizer box are aligned with those surrounding the return-air opening.
5. Using field-supplied  $\frac{1}{4}$  in. x  $\frac{3}{4}$  in. (maximum length) sheet metal screws, fasten the long economizer flanges to the matching return-air opening flanges and tighten all screws.
6. Using the four 10 x  $\frac{1}{2}$  in. self-tapping screws supplied, fasten the short economizer flanges to the matching return air opening flanges and tighten all screws.

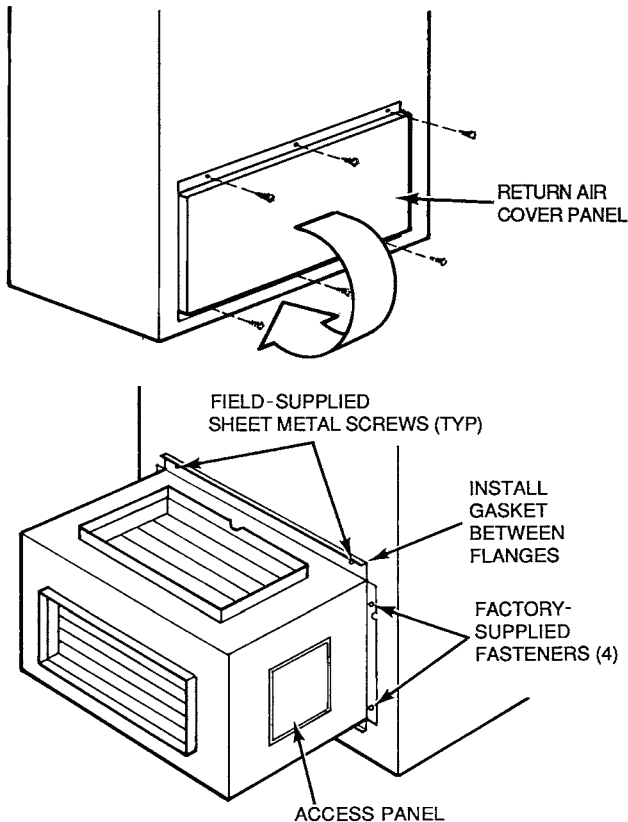

Fig. 3 — Economizer Installation on Vertical Unit

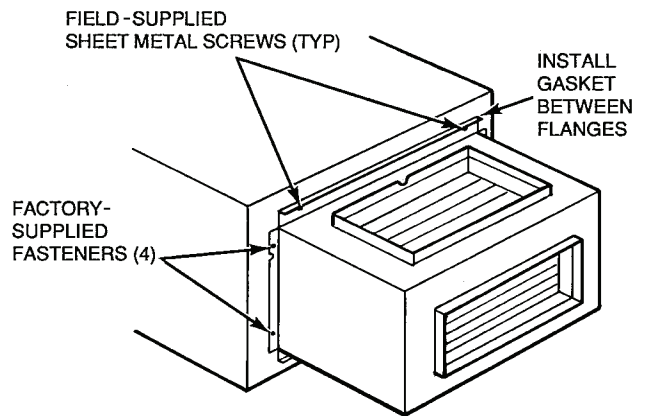

Fig. 4 — Economizer Installation on Horizontal Unit

**Install Transformer, Relay, and Supply-Air Temperature Sensor** — The transformer, relay, and supply-air temperature (SAT) sensor are shipped with the economizer accessory for field installation as follows:

**⚠ WARNING**

To prevent electrical shock and equipment damage, disconnect power supply before installing economizer components.

1. Remove the service panel from the control box end of the unit.
2. Mount the supply-air temperature sensor inside the air handler on the sensor mounting angle. Use the holes in the sensor base as guides to fasten the sensor to the mounting angle with field-supplied self-tapping screws, or drill holes into the mounting angle and fasten sensor in place with field-supplied sheet metal screws ( $3/4$ -in. maximum length). Locate the sensor in the middle of the mounting angle. See Fig. 5.
3. For air handlers without a circuit breaker in the control box (units with fan motor sizes less than 5 hp [3.73 kW]) mount the transformer and relay inside the control box. Use the holes in the transformer base and relay base as guides to drill holes into the box and fasten components in place with supplied no. 8 x  $1/2$  in. sheet metal screws. See Fig. 6.
4. For air handlers with a circuit breaker in the control box (units with fan motor sizes of 5 hp [3.73 kW] or greater), mount the supplied transformer and relay in a field-supplied and installed electrical box as shown in Fig. 6. Use the holes in the transformer base and relay base as guides to drill holes into the box and fasten components in place with supplied no. 8 x  $1/2$  in. sheet metal screws.

**Install Economizer, SAT Sensor, Relay, and Transformer Wiring**

**⚠ WARNING**

To prevent possible electrical shock and equipment damage, disconnect power supply before wiring economizer and components.

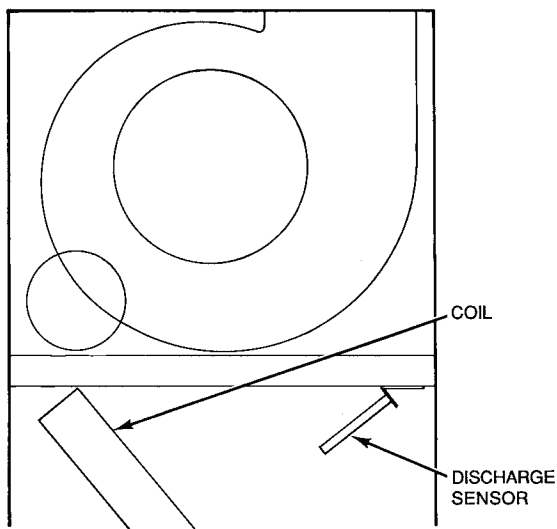

**Fig. 5 — Installing SAT Sensor**

1. Remove the economizer control access panel and locate the actuator wiring harness (on 25 and 30 ton units, the master actuator wiring harness). See Fig. 7 and 8.
2. Separate the orange and green wires from the wiring harness. Run the remaining wires in the wiring harness through the unit's return air opening.
3. Connect the gray wires to the supply-air temperature sensor leads as shown in Fig 9 and 10.
4. Remove the air handler control box cover and connect the yellow and blue wires to TB1 terminals Y1 and Y2.
5. Connect Y1 and Y2 from condensing unit or chiller to Y1 and Y2 on air handler terminal block TB1. Connections can be made using  $1/4$ -in. female quick connects (inside box) or with screw terminals (outside box). See Fig. 9 and 10.

NOTE: If the unit has single-stage cooling, terminate the blue wire with a wire nut and secure.

6. Route brown and red wires through control wiring access hole in unit corner post and connect to Y1 and Y2 from thermostat.

NOTE: If the unit has single-stage thermostat, terminate the brown wire with a wire nut and secure.

7. Connect black wire to transformer as shown in Fig. 9 and 10.
8. Using field-supplied wires, connect economizer relay (ER) coil to air handler terminals C and G. Connect white wire from transformer secondary to relay common contact. Connect white wire from harness to relay normally open contact.
9. Using field-supplied wire, connect line voltage power to transformer primary. There are taps for 200, 230, and 460-v power. (For 400-3-50 power, use the 460-v tap.) Connect power wire to correct tap and terminate any unused wires.
10. See pages 5-8 for enthalpy sensor wiring.

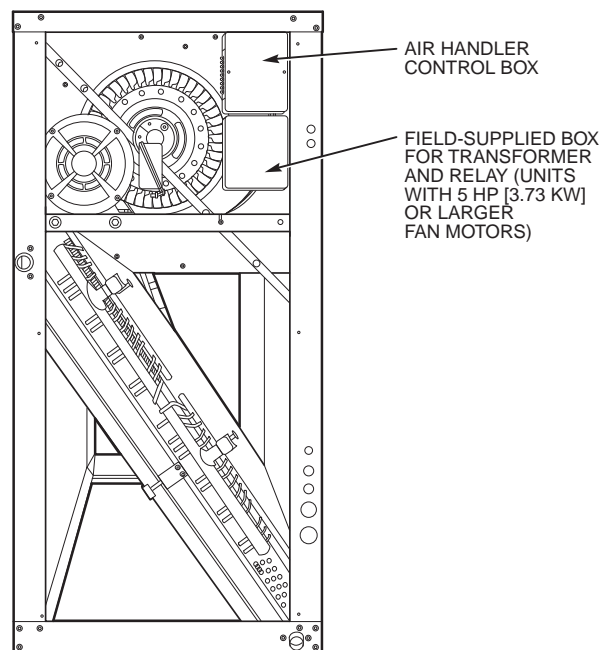

**Fig. 6 — Installing Economizer Transformer and Relay**

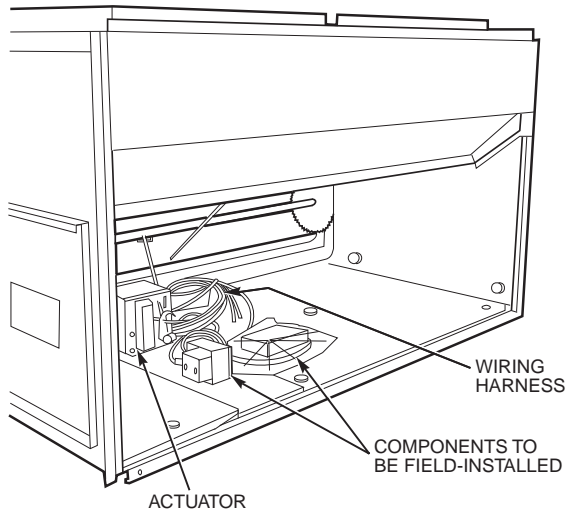

**Fig. 7 — Economizer Interior**

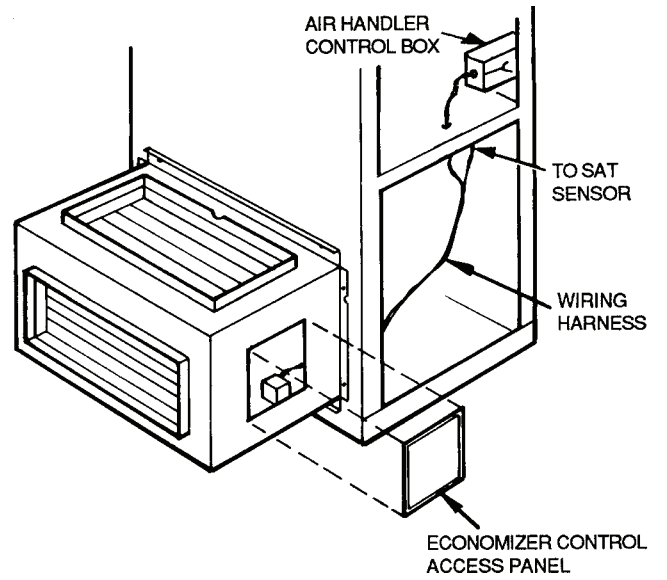

**Fig. 8 — Economizer Wire Routing**

TRANSFORMER SUPPLIED WITH ECONOMIZER ACCESSORY. PRIMARY HAS 200, 230 AND 460V TAPS. CONNECT TO LINE VOLTAGE SUPPLY USING CORRECT TAP.

### WIRING DIAGRAM FOR CAECOMZR001, 004, 002, 005A00

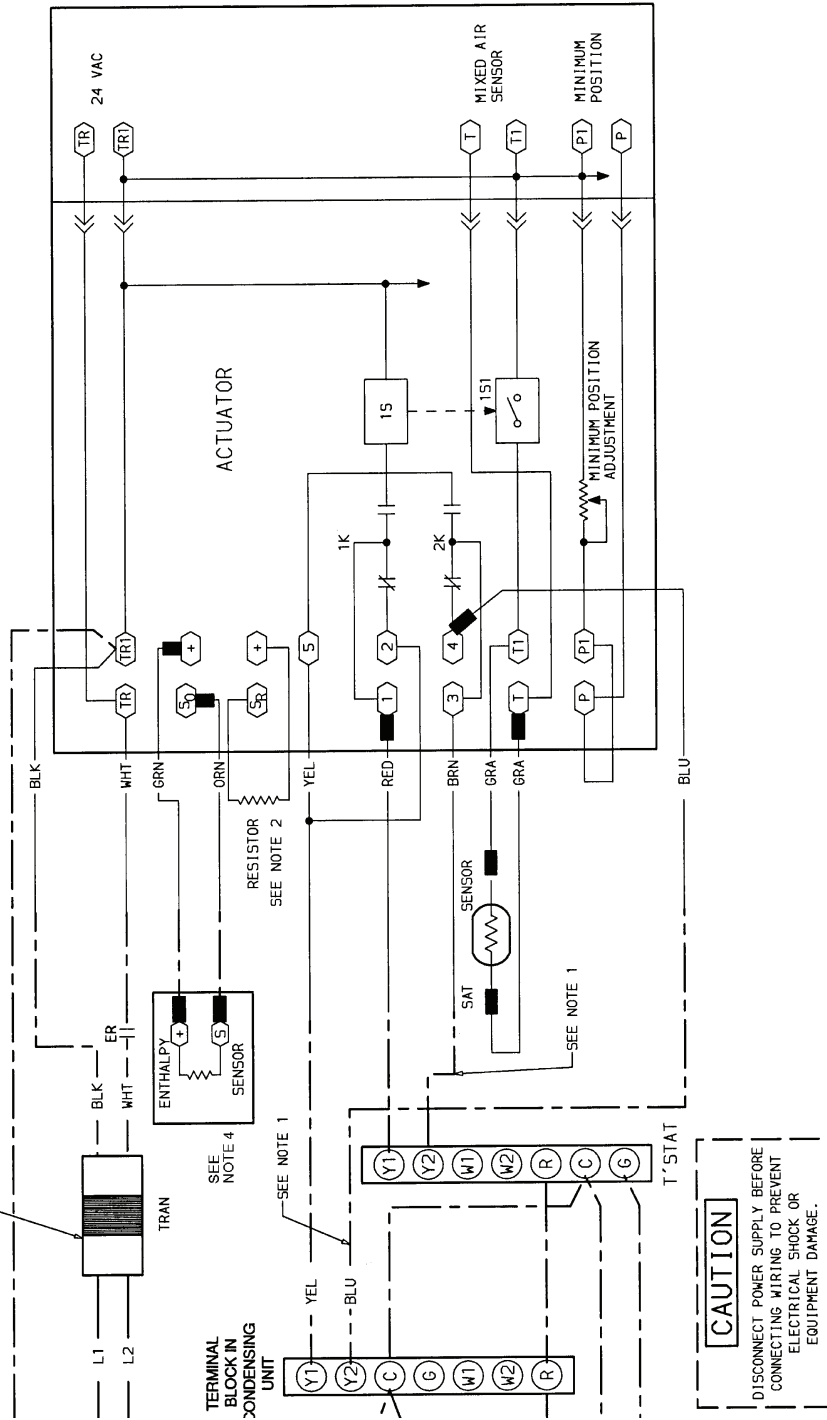

- LEGEND**
- SAT — Supply-Air Temperature
  - — Terminals
  - — Wire Nut or Equivalent Connection
  - (ER) — Economizer Relay
  - — Field Wiring
  - — Factory Wiring

**NOTES:**

1. If system has single-stage cooling, terminate the blue wire with a wire nut and secure. If thermostat is single-stage cooling, terminate the brown wire with a wire nut and secure.
2. Factory installed 620 ohm, 1 watt, 5% resistor should be removed only if a C7400 enthalpy sensor is added to SR and + for differential enthalpy.
3. Economizer relay closes outside air damper when fan coil blower is not powered.
4. Enthalpy sensor can be located up to 200 ft away from economizer. Use field-supplied 2-conductor 18 AWG (American Wire Gage) wire.

**Fig. 9 — Economizer Wiring, 6 to 20 Ton Units**

**WIRING DIAGRAM FOR CAECOMZR003A00, 006A00**

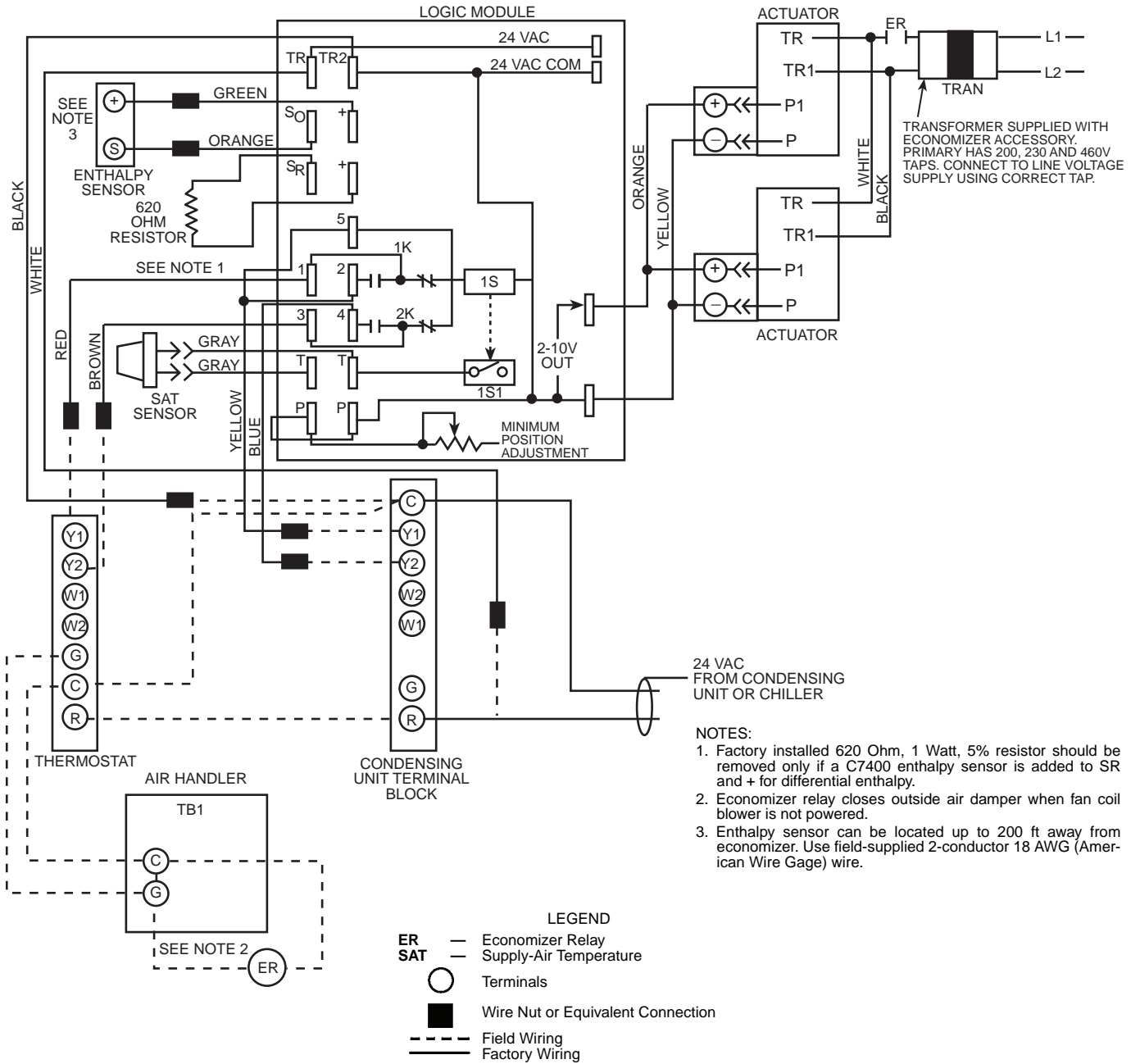

**Fig. 10 — Economizer Wiring, 25 and 30 Ton Units**

## Applications Using a Single Enthalpy Sensor: Installing Enthalpy Sensor and Connecting Ductwork

NOTE: An optional differential enthalpy sensor (part no. [HH57AC078](#)) mounts in the return air duct and can be used for differential enthalpy control. If using differential enthalpy sensors to control unit, see following section for installation instructions.

Refer to Fig. 11 and perform the following steps:

1. Size the outdoor air ductwork according to the sizes for the damper flanges shown in Fig. 2.
2. Attach return-air duct to economizer return-air damper, caulk and secure in place. Ensure damper blades are unobstructed.
3. Mount the supplied enthalpy sensor (Fig. 12) inside outdoor-air duct no more than 200 feet from the unit, as shown in Fig. 11. Use the holes in the sensor base as guides to fasten it to the duct with supplied self-tapping screws, or drill holes into the duct and fasten the sensor in place with field-supplied sheet metal screws.

**IMPORTANT:** Mount enthalpy sensor where it is exposed to fresh outdoor air, but NOT exposed to rain, snow, or direct sunlight.

4. Run the orange and green wires from the economizer wiring harness to the enthalpy sensor, remove knock-out in top of economizer cabinet and drill or punch holes in side of duct to route wiring according to the application. Connect the orange wire to terminal S<sub>o</sub> and green to terminal +. See Fig. 9 and 10.

### ⚠ CAUTION

Route wiring harness carefully to avoid blocking filters or contacting moving parts.

5. Attach outdoor-air duct to economizer outdoor-air damper. Caulk and secure in place. Ensure damper blades are unobstructed.
6. Using supplied P-clamps, secure the wiring harness to the unit.
7. Replace air handler service panel.

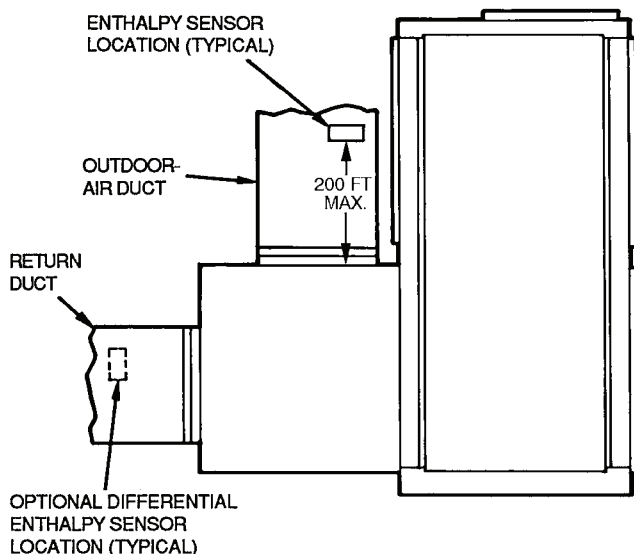

Fig. 11 — Installing the Enthalpy Sensor

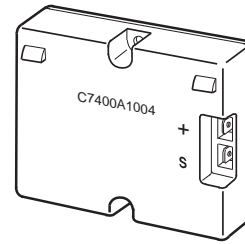

Fig. 12 — Enthalpy Sensor

## Applications Using Differential Enthalpy Sensors: Installing Enthalpy Sensors and Connecting Ductwork — Refer to Fig. 11 and perform the following steps:

1. Size the supply air ductwork according to the sizes for the damper flanges shown in Fig. 2.
2. The economizer accessory includes one enthalpy sensor. If economizer operation based on enthalpy differential between outdoor and return air is desired, differential enthalpy sensor part no. [HH57AC078](#) (Honeywell part no. C7400A1004) must be ordered. See Fig. 12.
3. Mount the differential enthalpy sensor inside return air duct as shown in Fig. 11. Use the holes in the sensor base as guides to fasten it to the duct with self-tapping screws, or drill holes into the duct and fasten the sensor in place with field-supplied sheet metal screws.
4. Remove the factory-installed 620-ohm resistor from between economizer actuator terminals SR and +. See Fig. 9 and 10.
5. Using field-supplied wires, connect the differential enthalpy sensor terminal S to actuator terminal SR and sensor terminal + to actuator terminal +. Remove knockout in top of economizer cabinet and drill or punch holes in side of duct to route wiring according to the application.
6. Attach return-air duct to economizer return-air damper. Caulk and secure in place. Ensure damper blades are unobstructed.
7. Mount the enthalpy sensor inside outdoor-air duct as shown in Fig. 11. Use the holes in the sensor base as guides to fasten it to the duct with self-tapping screws, or drill holes into the duct and fasten the sensor in place with field-supplied sheet metal screws.

**IMPORTANT:** Mount enthalpy sensor where it is exposed to fresh outdoor air, but NOT exposed to rain, snow, or direct sunlight.

8. Run the orange and green wires from the economizer wiring harness to the enthalpy sensor; remove knock-out in top of economizer cabinet and drill or punch holes in side of duct to route wiring according to the application. Connect the orange wire to terminal S<sub>o</sub> and green to terminal +. See Fig. 9 and 10.

### ⚠ CAUTION

Route wiring harness carefully to avoid blocking filters or contacting moving parts.

9. Attach outdoor-air duct to economizer outdoor-air damper. Caulk and secure in place. Ensure damper blades are unobstructed.
10. Using supplied P-clamps, secure the wiring harness to the unit.
11. Replace air handler service panel.

**Adjust Enthalpy Setting and Minimum Damper Position** — The economizer actuator has a control module (Fig. 13) with 2 adjustable settings; one for enthalpy and another to control the minimum position for the outdoor air damper. The enthalpy setting is determined by a 4-position selector switch. Settings A-D refer to the psychrometric chart in Fig. 14. Choose an enthalpy setting according to the desired operation displayed in the chart. The economizer opens when enthalpy is below the selected setting.

The outdoor air damper minimum position can be set with the potentiometer on the control module. See Fig. 13. After choosing the setting, check the damper's minimum position operation by using the thermostat to cycle the air-handling unit in and out of cooling mode.

When adjustments are complete, replace the economizer control access panel.

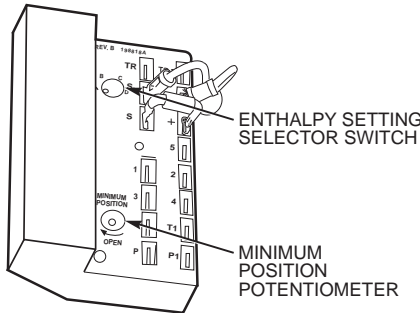

**Fig. 13 — Economizer Control Module**

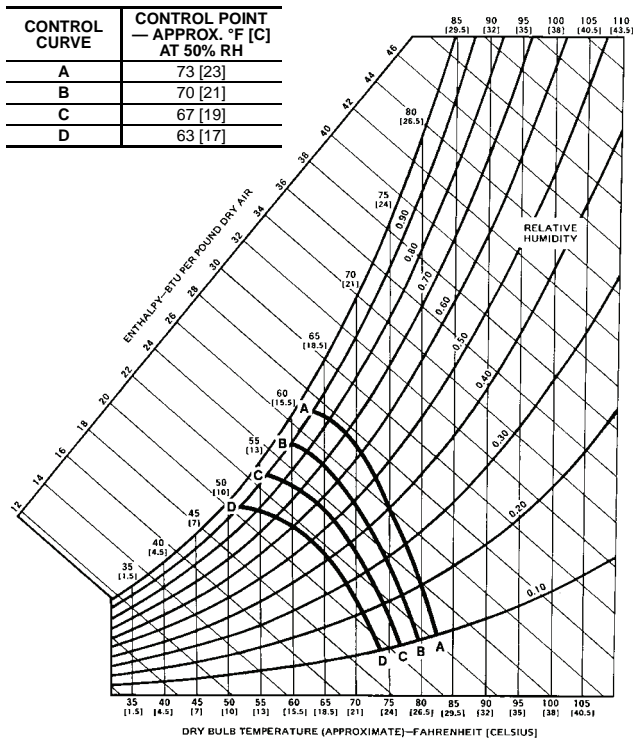

RH — Relative Humidity

**Fig. 14 — Psychrometric Chart for Enthalpy Control**

**Using a CO<sub>2</sub> Sensor with the Economizer** — A separately ordered carbon dioxide sensor (Fig. 15) can be used to signal the economizer to open the outdoor-air dampers to admit fresh air and dilute the indoor CO<sub>2</sub> level. Sensor descriptions and part numbers are shown in Table 3. To mount the sensor, refer to the installation instructions shipped with the sensor.

**Table 3 — CO<sub>2</sub> Sensor Accessories**

CO <sub>2</sub> SENSOR ACCESSORY PART NUMBERS	DESCRIPTION
33ZCSENC02	Wall Mount Sensor
33ZCASPC02	Duct Mount Aspirator Box

The CO<sub>2</sub> sensors listed in Table 3 are factory set for a range of 0 to 2000 ppm and a linear voltage output of 2 to 10 vdc. The relay normally open dry contacts (TB-3 and TB-4) are factory set to close at 1000 ppm. Refer to the instructions supplied with the CO<sub>2</sub> sensor for electrical ratings of contacts and information on connecting to power supply. Switch contacts can be used to set off an alarm or light to indicate CO<sub>2</sub> levels higher than the switch set point.

Any changes to the factory configuration require the purchase of the User Interface Program (UIP) or Sensor Calibration Service Kit, which also contains the UIP. For correct modulation of the economizer actuator motor, a separately ordered adapter (Honeywell part no. Q769C1007) is required.

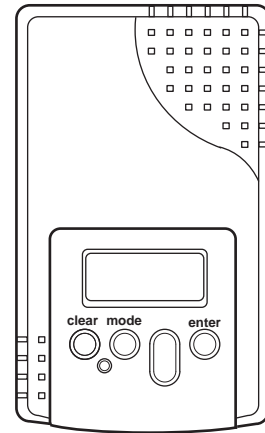

**Fig. 15 — CO<sub>2</sub> Sensor**

**CO<sub>2</sub> SENSOR INSTALLATION WITH ECONOMIZER AND STANDARD THERMOSTAT** — The economizer and enthalpy sensor(s) must be installed before installing and testing the CO<sub>2</sub> sensor. When the CO<sub>2</sub> sensor is installed with the economizer and a standard thermostat, the economizer modulates open when the leaving-air temperature demand requires greater airflow than the airflow demand generated by the CO<sub>2</sub> sensor to reduce carbon dioxide levels. When the CO<sub>2</sub> sensor is installed, there is no minimum leaving air temperature control at the economizer.

Use field-supplied 14 AWG (American Wire Gauge) power wiring to connect the CO<sub>2</sub> sensor as follows.

**⚠ WARNING**

To prevent electrical shock, disconnect all power before installing or wiring sensors.

1. On the actuator logic module, remove the black jumper wire connecting P and P<sub>1</sub>.
2. Using a small screwdriver, adjust the minimum position potentiometer fully clockwise (open).

3. Using field-supplied wire and terminals, connect J8-8 from the CO<sub>2</sub> sensor to the + terminal on the front of adapter part no. Q769C1007. Connect J8-7 to the - terminal. See Fig. 16 and 17.
4. On the back of the adapter there are two slots that accept 1/4-in. male quick-connect terminals. See Fig. 17. Using field-supplied wire, connect the + terminal on the back of the adapter to P<sub>1</sub> on the logic module. Connect the - terminal on the back of the adapter to terminal P on the logic module.

ADJUSTING ADAPTER NO. Q769C1007 — The adapter is factory-set to begin modulating the actuator open from the fully closed position at 2.4 vdc and closed from the fully open position at 9.8 vdc, with the calibration potentiometer (Fig. 17) set at the midrange position. The potentiometer can be used to adjust the minimum damper position. Turning the potentiometer counterclockwise increases the damper's minimum position setting; turning the potentiometer clockwise decreases the minimum position setting.

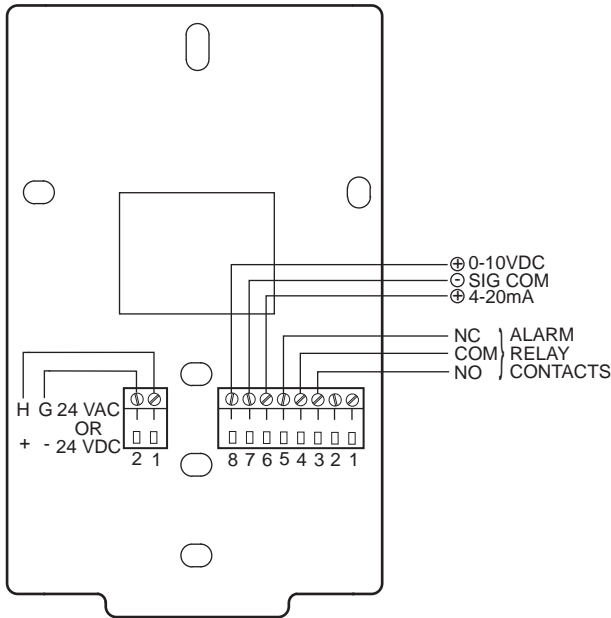

**Fig. 16 — CO<sub>2</sub> Sensor, Wiring Connections**

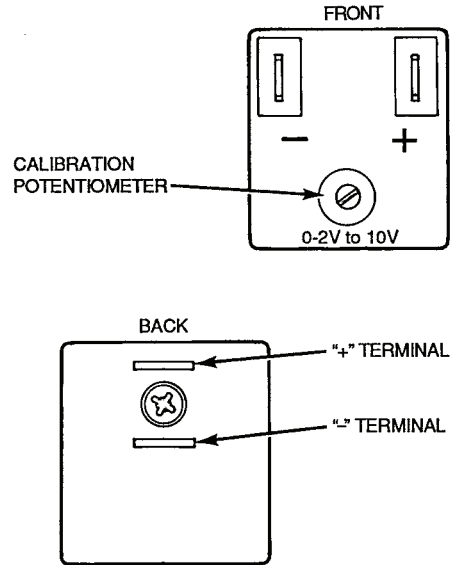

**Fig. 17 — Adapter Connections**

## SEQUENCE OF OPERATION — AIR HANDLER WITH ECONOMIZER

This sequence is based on an installation where the economizer has been correctly installed on the air-handling unit, and the entire HVAC system (including the air handler, economizer actuators, condensing unit or chiller, and thermostat) have been powered on.

When the thermostat turns the indoor fan on, the economizer relay is energized and the actuator(s) are powered on. The actuator(s) move the dampers to the minimum positions as determined by the adjustment potentiometer on the actuator or master actuator. If the system uses a CO<sub>2</sub> sensor, the minimum position is determined by the potentiometer on the required field-supplied adapter.

On a call for heating from the thermostat (W1 and/or W2 energized), the economizer remains at the minimum position.

NOTE: If a CO<sub>2</sub> sensor is used, the economizer can modulate based on the carbon dioxide level in the space. There is no low leaving-air temperature limit control. Controls to accomplish this must be field-supplied and installed.

On a call for cooling from the thermostat (Y1 energized), the actuator logic module determines if the outdoor air enthalpy is acceptable according to the set point on the actuator. If the outdoor air enthalpy is acceptable, the economizer begins to modulate open and is controlled to maintain a 56 F leaving air temperature. If outdoor air enthalpy is unacceptable, the logic module bypasses the use of outdoor air and energizes Y1 at the condensing unit or chiller.

On a call for a second stage of cooling (Y2 energized), the actuator energizes Y1 at the condensing unit or chiller if the outdoor air enthalpy is acceptable. If the outdoor air is unacceptable, the actuator logic module energizes Y2 at the condensing unit or chiller.

If the system is equipped with a CO<sub>2</sub> sensor in a modulating configuration, the following applies: If the system is operating in the Cooling mode and the demand for fresh air to reduce the carbon dioxide level in the space is greater than the cooling load demand, the actuator modulates to reduce the carbon dioxide level and does not modulate towards closed if the leaving-air temperature is below 56 F. If, however, the cooling demand is greater than the demand to reduce the carbon dioxide level, the actuator modulates open and controls to a 56 F leaving-air temperature.

### START-UP

After installing and wiring the economizer and sensors, perform the following start-up steps:

1. Set the thermostat to OFF. Set the cooling and heating set points to minimum.

2. Start the air handler and the condensing unit according to the base unit installation instructions.
3. At the thermostat, turn the fan to ON. The air handler starts and the outdoor air dampers move to the minimum position. If a different minimum vent position is required, adjust the minimum position potentiometer on the economizer control module.
4. Set the thermostat to HEAT or AUTO mode. Raise the heating mode set point until the first stage of heat comes on at the air handler and check for correct heating cycle operation according to the instructions shipped with the heating device. Through the access panel on the side of the economizer, check to see that the economizer outdoor air damper stays in the minimum vent position. If heat does not operate correctly or damper does not stay in minimum vent position, recheck and correct wiring.
5. Repeat the procedure from the previous step to engage the second stage of heating (if present), and again check to make sure that the economizer outdoor air damper stays in the minimum vent position.
6. Set the thermostat to COOL or AUTO mode. Reduce the set point to activate the first stage of cooling.

If the outdoor air enthalpy is above the set point on the enthalpy sensor, the first stage of mechanical cooling is turned on. If the cooling set point is reduced further, the second stage of cooling is activated.

If the outdoor air enthalpy is below the set point on the economizer control module, the first stage call for cooling opens the economizer outdoor-air dampers. (It may be necessary to temporarily set the enthalpy switch to the "A" setting to check for correct damper operation.) If the cooling set point is reduced further, the first stage of mechanical cooling is turned on.

NOTE: The economizer controls the dampers to maintain a supply-air temperature of 56 F when the enthalpy is suitable.

7. As the cooling stages are engaged, verify correct operation of the cooling stages and the economizer dampers.
8. Verify linked damper/CO<sub>2</sub> sensor operation by blowing on sensor and observing damper operation. Monitor the dc voltage on actuator logic module terminals P and P<sub>1</sub> when testing damper operation. The sensor must register 1000 ppm or higher (approximately 6 vdc) to activate relay contacts.

