

Packaged Air-Handling Units 6 to 30 Tons Hot Water and Steam Coil Accessories

Cancels: IIK 524A-72-8 IIK 524A-72-16
1/1/05

Installation Instructions

Part Nos. CAHWCOIL001A00 – CAHWCOIL003A00 (Hot Water Coil),
CASTCOIL001A00 – CASTCOIL003A00 (Steam Coil)

SAFETY CONSIDERATIONS

Installation of this accessory can be hazardous due to electrical components and equipment location (such as a ceiling or elevated structure). Only trained, qualified installers and service mechanics should install and service this equipment.

When installing this accessory, observe precautions in the literature, labels attached to the equipment, and any other safety precautions that apply.

- Follow all safety codes.
- Wear safety glasses and work gloves.
- Use care in handling and installing this accessory.

	<p>ELECTRIC SHOCK HAZARD</p> <p>To avoid the possibility of electrical shock, open and tag all disconnects before installing this equipment.</p>
--	---

⚠ CAUTION
<p>Wear a hard hat and safety shoes when working in an area where there is danger of falling objects. Wear safety glasses to protect your eyes. When welding, brazing or cutting, wear gloves and goggles for personal protection.</p> <p>Follow safe rigging practices when handling larger coils. Refer to ANSI Z49.1 (latest edition) for American Welding Society Standards of safe welding and flame cutting practices.</p> <p>All field piping must conform to local codes.</p>

INTRODUCTION

The hot water and steam coil accessories provide blow-thru heat sources for 6 to 30 ton packaged air-handling units. The

coils are mounted directly over the unit fan discharge(s), and do not require duct flanges; see Fig. 1. Table 1 shows accessory kit weight and contents.

PREINSTALLATION

Complete Preinstallation Checks — Remove accessory packaging and inspect shipment for damage. File claim with shipping company if accessory is damaged or incomplete.

Check Unit Clearance — Provide sufficient space for airflow clearance and servicing accessory after it is mounted on unit. The base unit minimum clearances of 2½ ft for front and sides of unit and 3 in. for rear of unit also apply to the hot water and steam coils.

INSTALLATION

Prepare Coil Box — Before mounting the coil box on the air handler, seal strips must be installed in the coil box as follows:

1. Turn the coil over so that the 4 mounting flanges are exposed and the header connections are at the bottom of the coil box. See Fig. 2.
2. Fasten 4 lengths of the supplied self-adhesive seal strip on top of the horizontal flanges that are now facing up. See Fig. 2. When the coil box is turned over and mounted on the unit, these strips will rest on top of the unit cabinet. For coil part numbers ending in 1A00 and 2A00, all flanges are on the inside of the coil box. For coil part numbers ending in 3A00 (25 and 30 ton units), one flange is on the outside of the coil box and the other 3 flanges are on the inside of the box. Holes in flanges provide clearance for existing screws in top of unit.

Table 1 — Accessory Contents and Weight

UNIT SIZE	COIL TYPE	PART NO.	WEIGHT, lb (kg)	KIT CONTENTS
6 to 10 Tons	Hot Water	CAHWCOIL001A00	195 (88.6)	Coil Assembly 22 ft Seal Strip 12 Self-Tapping Screws, ¼-in.
	Steam	CASTCOIL001A00	215 (97.7)	
12½ to 20 Tons	Hot Water	CAHWCOIL002A00	285 (129.5)	Coil Assembly 36 ft Seal Strip 20 Self-Tapping Screws, ¼-in.
	Steam	CASTCOIL002A00	340 (154.5)	
25 to 30 Tons	Hot Water	CAHWCOIL003A00	345 (156.8)	Coil Assembly 39 ft Seal Strip 24 Self-Tapping Screws, ¼-in.
	Steam	CASTCOIL003A00	405 (184.1)	

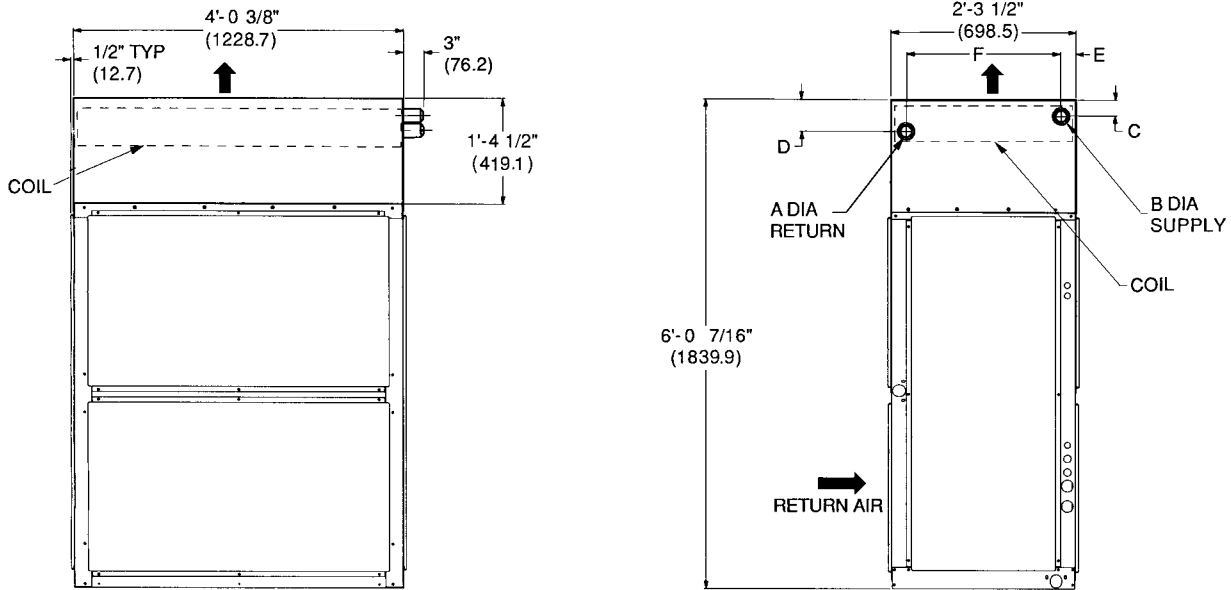

DIMENSION	HOT WATER COIL	STEAM COIL
A	1 1/2" MPT (38.1)	1 1/2" MPT (38.1)
B	1 1/2" MPT (38.1)	2 1/2" MPT (63.5)
C	2 1/2" (63.5)	2 13/16" (71.4)
D	5 1/4" (133.4)	2 13/16" (71.4)
E	2 1/8" (54.0)	4 9/16" (115.8)
F	1'-11 1/4" (590.6)	1'-9" (584.2)

NOTE: Dimensions in () are millimeters.

6 TO 10 TON UNITS

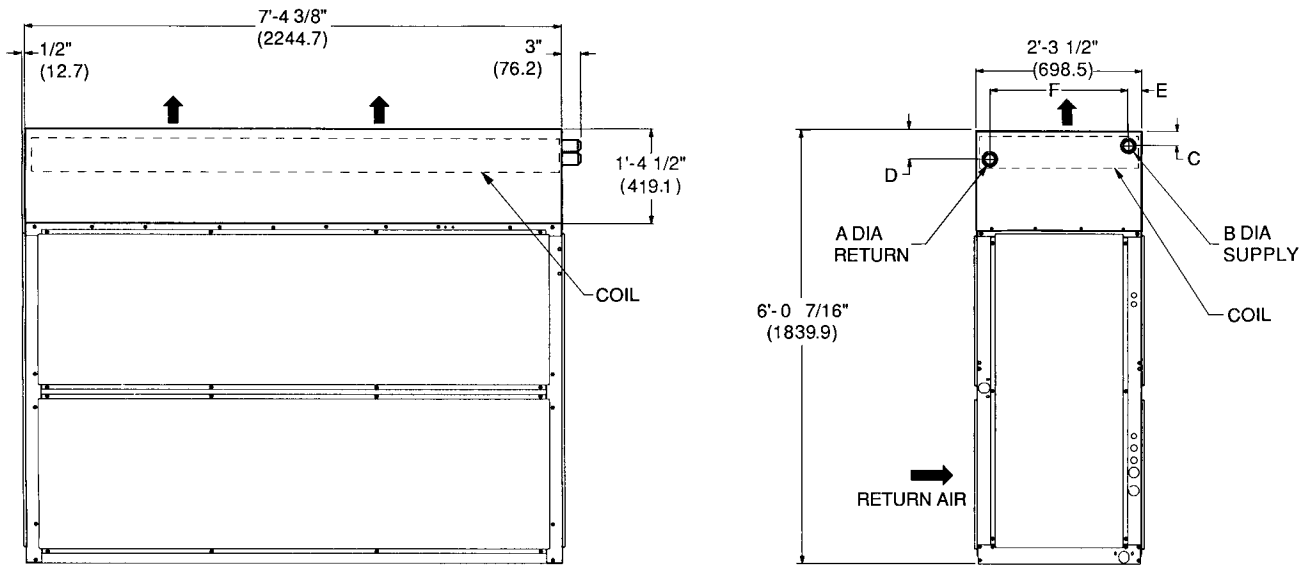

DIMENSION	HOT WATER COIL	STEAM COIL
A	2" MPT (50.8)	1 1/2" MPT (38.1)
B	2" MPT (50.8)	2 1/2" MPT (63.5)
C	2 1/2" (63.5)	2 13/16" (71.4)
D	5 1/4" (133.4)	2 13/16" (71.4)
E	2 1/8" (54.0)	4 9/16" (115.8)
F	1'-11 1/4" (590.6)	1'-9" (584.2)

NOTE: Dimensions in () are millimeters.

12 1/2 TO 20 TON UNITS

Fig. 1 — Coil Mounted on Unit (Hot Water Coil Shown)

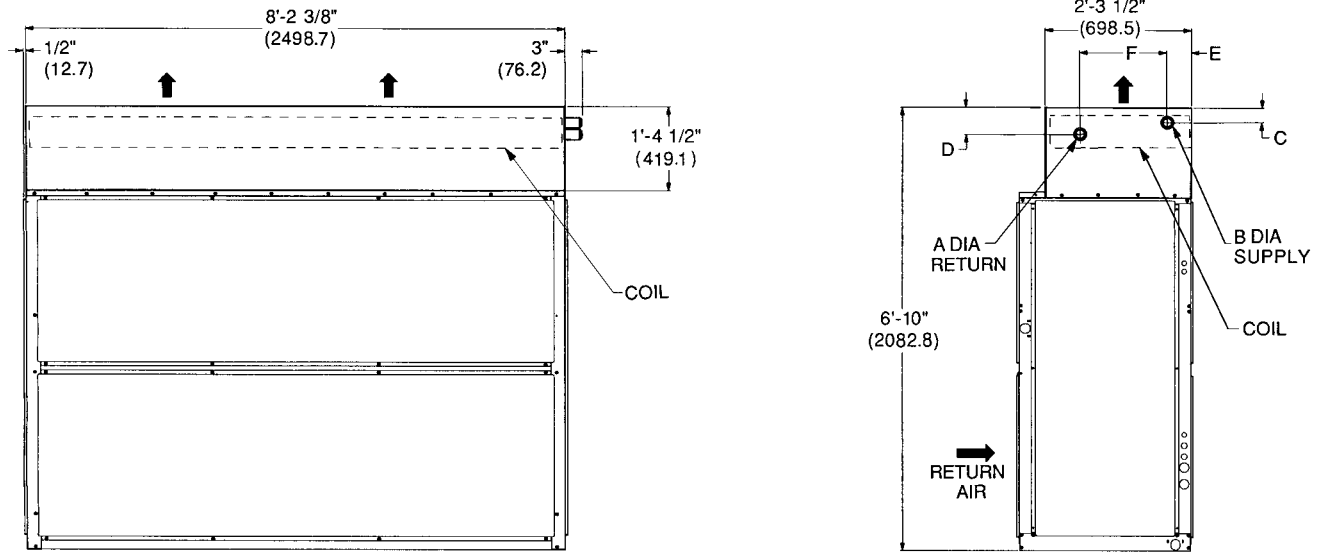

DIMENSION	HOT WATER COIL	STEAM COIL
A	2" MPT (50.8)	1 1/2" MPT (38.1)
B	2" MPT (50.8)	2 1/2" MPT (63.5)
C	2 1/2" (63.5)	2 13/16" (71.4)
D	5 1/4" (133.4)	2 13/16" (71.4)
E	2 1/8" (54.0)	4 9/16" (115.8)
F	1'-11 1/4" (590.6)	1'-9" (584.2)

NOTE: Dimensions in () are millimeters.

25 AND 30 TON UNITS

Fig. 1 — Coil Mounted on Unit (Hot Water Coil Shown) (cont)

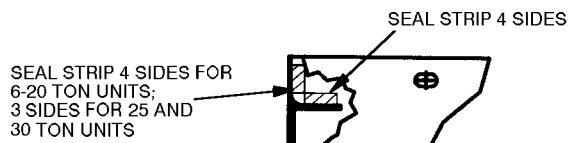
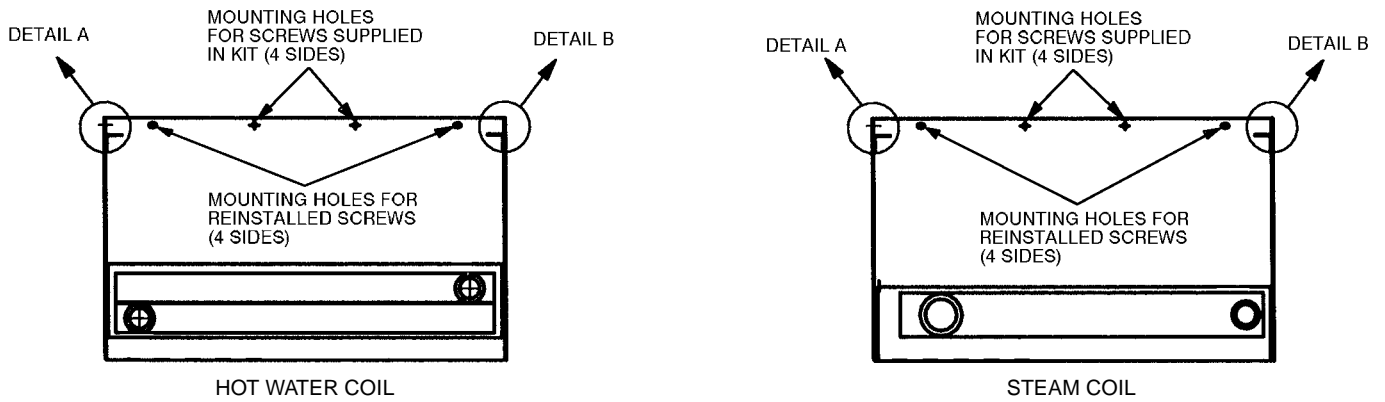

DETAIL A

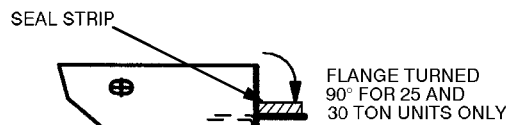

DETAIL B

Fig. 2 — Installing Seal Strips

- Using 4 additional lengths of the supplied seal strip (3 for 25 and 30 ton units), remove the backing from the strip and fasten it around the top inside edge of the coil box (that is now facing up). The strips cover the mounting screw holes. When the coil box is turned over and placed on the unit, these strips seal the vertical gap between the coil box and the sides of the unit. See Fig. 2.

Mount Coil — The coil must be mounted over the supply outlets of the air handler for blow-thru operation, as shown in Fig. 1. Do not install the duct flange(s) shipped with the unit.

⚠ CAUTION

Place coil box on unit carefully so that seal strips on the insides of the coil box are not peeled off or damaged. Seal strips should rest against the top and sides of the air handler and should not prevent coil box from resting flush on the unit.

Mount the coils as follows:

- For unit sizes up to and including 20 tons (accessory part numbers ending in 1A00 and 2A00), remove the screws from the top edge of each corner of the unit. For 25 and 30 ton units (accessory part numbers ending in 3A00), remove the screws from the top corner of the unit only on the back and the side of the unit nearest to the back. Retain screws for reinstallation. See Fig. 1.
- Place the coil on top of the unit so the heating coil header connections face up and have the same “hand” as the cooling coil connections. The bottom of the coil box must overlap the front, back, and sides of the unit. (The 25 and 30 ton coil box overlaps the top of the unit on 3 sides only). Align the corner slots in the coil box base with the matching holes in each of the top corners of the unit. The seal strip blocks the holes, so use a sharp probe to penetrate the seal and align the slots and holes if necessary.
- Reinstall the screws removed in Step 1 through the base of the coil box into the corners of the unit. For 25 and 30 ton units only, use the corner holes in the coil flange that rests on top of the unit and the closest holes on the sides of the coil box as guides to drill holes in the unit. Fasten the coil box to the unit at these 4 points with self-tapping screws supplied in the kit. See Fig. 1-3.

NOTE: Use only the screw slots in the corners of the coil box sides to attach the screws removed in Step 1. Remaining holes along each bottom edge of the coil box are for self-tapping screws supplied with the kit. See Fig. 2.

- Use the remaining holes in the coil box sides as guides to drill additional mounting holes in the unit. For 25 and 30 ton units, one flange rests on top of the unit. See Fig. 1 and 2.

- Fasten bottom sides of coil box to sides of unit with self-tapping screws supplied. See Fig. 1.
- If desired, seal the top 4 corners of the coil box and the 4 corners where the coil box joins the unit with clear silicone sealant.

NOTE: Figure 1 shows vertical installations; for horizontal installations, mount the coil accessory as shown and rotate the entire unit/coil assembly 90 degrees. For established horizontal unit installations, the procedure for mounting the coil accessory is similar to the preceding steps; ensure that the accessory coil hand is correct when installing the coil horizontally.

⚠ CAUTION

Coil accessories mounted on horizontal ceiling-suspended units must have their own supports in addition to the base unit supports. DO NOT support weight of coil on mounting screws that attach coil box to unit. Equipment damage and personal injury can result.

The overhead suspension accessory is available for horizontal ceiling-supported units. See the overhead suspension accessory Installation Instructions for further information on supporting coil accessories in horizontal installations.

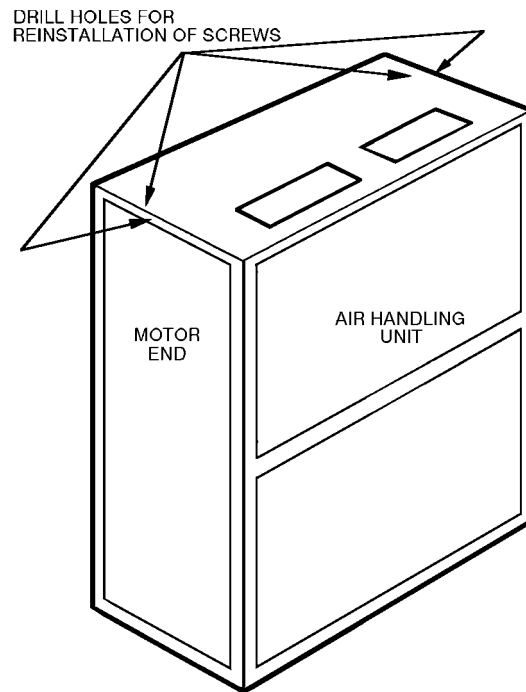

Fig. 3 — Drilling Locations for Reinstalling Screws in Coil Box — 25 and 30 Ton Units

Connect Ductwork — Connect supply duct to the unit and coil assembly as follows:

1. Size the supply air ductwork according to the discharge opening(s) in the top of the coil box. See Fig. 4. Refer to base unit installation instructions for typical duct designs.
2. Connect the supply duct to the top of the coil box with field-supplied self-drilling screws that do not exceed 3/4-in. length. See Fig. 5.

CAUTION
DO NOT use screws longer than 3/4-in. to attach ductwork to coil box. Longer screws can puncture and damage the coil.

3. Coil boxes are internally insulated; they do not require external insulation. Insulate the supply duct connected to the heater as required by the application.

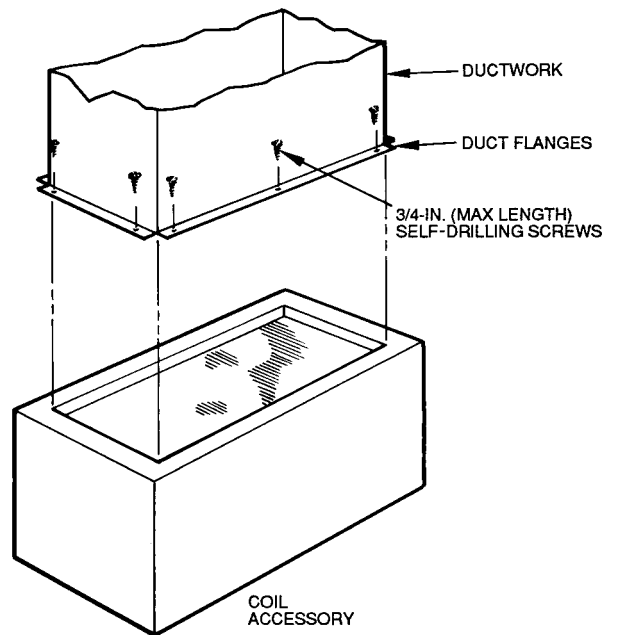
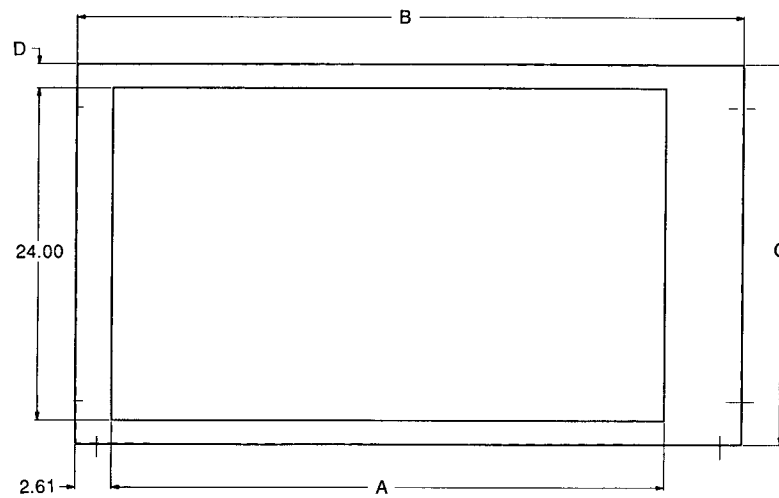

Fig. 5 — Connecting Ductwork



DIMENSIONS (in.)

UNIT SIZES	A	B	C	D
6 to 10 Tons	40.00	48.35	27.53	1.73
12 to 20 Tons	80.00	88.35	27.53	1.73
25 and 30 Tons	90.00	98.35	27.53	1.73

Fig. 4 — Coil Box Dimensions — Duct Connection

Steam Coil Piping — See Fig. 6 and 7 for suggested steam coil piping and location of check valves in atmospheric or vacuum return systems.

A vacuum-return system is recommended to provide steam coil freeze-up protection. Vacuum-breaker check valves should be installed to eliminate residual condensate from the coil before the condensate can freeze. *Use only 15-degree swing check valves for this purpose.*

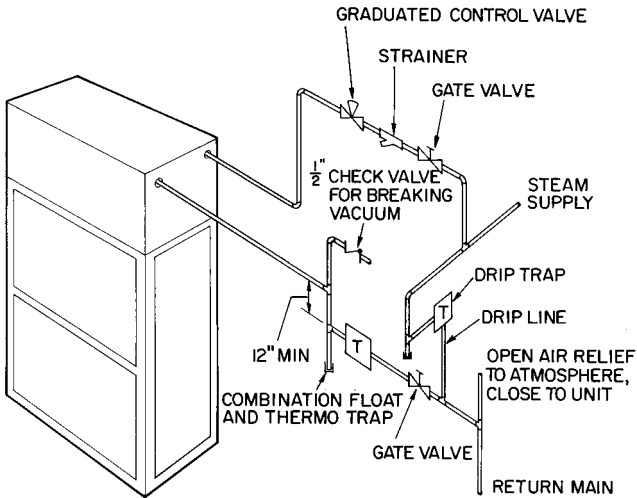

NOTE: Run coil return piping full size to trap.

Fig. 6 — Typical Steam Distributing Coil Piping for Open Gravity Systems with Steam Pressure Below 10 Psig

Hot Water Coil Piping — See Fig. 8 for typical hot water coil piping and recommended valve locations.

CONTROL RECOMMENDATIONS

Several methods of control are possible, depending on the heating medium to be used, location and type of thermostatic control, and whether or not a modulating or ON/OFF type of control is used. Figure 9 shows a typical control schematic for a hot water heating coil used on a chilled water unit. The use of a manual changeover (cooling-heating) switch is recommended. A 24-v heating-cooling thermostat can be used, with the heating thermostat wired as shown in Fig. 9. For typical base unit controls, see the base unit Installation Instructions.

START-UP

1. Turn on unit power.
2. Set fan switch at ON position to energize indoor air fan.
3. Turn on hot water or steam supply.
4. Set heating thermostat to activate heating coil.
5. Check heating effect at air outlet(s).

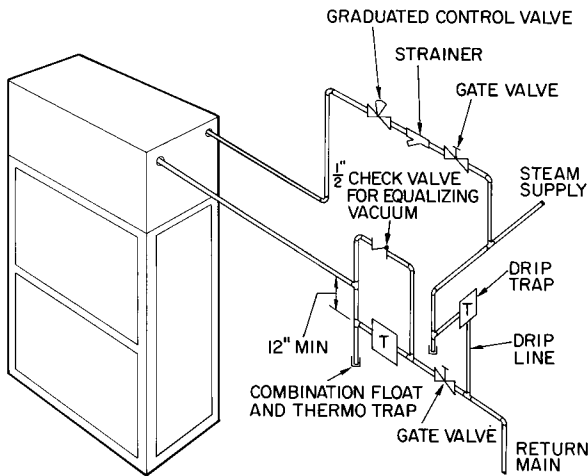

NOTE: Run coil return piping full size to trap.

Fig. 7 — Typical Steam Distributing Coil Piping for Vacuum-Return Systems with Steam Pressure Below 10 Psig

SERVICE

⚠ CAUTION

Before servicing the unit piping, shut off and tag the steam and hot water valves.

See Cautions under Safety Considerations section on page 1.

Disconnect power to base unit to avoid electrical shock when servicing.

Cleaning Coils — Refer to base unit instructions regarding unit panel removal for coil access. Clean coil fins with a stiff brush, vacuum cleaner, or compressed air. Use a fin comb with teeth of correct spacing when straightening mashed or bend coil fins. Procedure and precautions for cleaning heating coil are similar to those regarding cleaning of evaporator coil as described in base unit instructions.

Venting and Draining Coils — Coil may be vented or drained as required by removing plug from vent or drain in coil headers.

Protecting Coils Against Freezing — Whenever a steam or hot water heating coil is subjected to freezing temperatures, some means of adequate freeze protection is required. A heating coil can be subjected to freezing temperatures by outside air during the winter, or by its proximity to the cooling coil during the summer.

HOT WATER COILS — During winter operation, either the outside-air supply must be closed off or a minimum water flow must be maintained if outside air is admitted. For summer operation, it is recommended that the hot water coil be closed off, drained, and any residual water blown out. If the residual water cannot be blown out, an inhibited glycol antifreeze should be added to the coil.

STEAM DISTRIBUTING COILS — For summer operation, the same general precautions should be taken for steam coils as for hot water coils.

During heating operation, the vacuum-return system is recommended since it helps eliminate any residual condensate from the coil.

The steam distributing coils have a significantly reduced possibility of freeze-ups. They are still susceptible to freezing, however, if a minimum steam quantity is not maintained where air over the coil approaches 32 F, or if they are not properly pitched, drained, trapped, and controlled.

The following points should also be considered for the freeze protection of steam distributing coils.

1. In cases where outside air is admitted to the unit, it should be sufficiently mixed with return air before reaching the coil in order to avoid cold spots on the coil. It is important that a minimum steam quantity be maintained when heat is called for to prevent water remaining in the tubes and possibly freezing. The ON-OFF type of steam control is preferred over a modulating control where air over coil temperatures approach 32 F. Make sure that closed outside-air dampers are sufficiently sealed to prevent air leakage.
2. Make sure that the coil is properly pitched, drained, and trapped so that condensate drains out of the coil whenever the control valve shuts off the steam supply.