



5925 Heisley Road • Mentor, OH 44060-1833

KoldCube ³ Refrigerated Cabinet	FL-2379
Rev. 1 (7/19)	Page 1 of 9

OPERATING and MAINTENANCE INSTRUCTIONS for Cres Cor Refrigerated Cabinet, Models KCUA11 & KCUA11H



**KC-UA-11
KC-UA-11H**

Cabinet model number: _____

Cabinet serial number: _____

Authorized Service Agency: _____

Ph: _____ Fax: _____

Keep this manual for future reference.

KoldCube [®] Refrigerated Cabinet	FL-2379
Rev. 1 (7/19)	Page 2 of 9



5925 Heisley Road • Mentor, OH 44060-1833

INSTALLATION & OPERATING INSTRUCTIONS

Model	Volts	Amps	Battery Type	Battery Capacity
KCUA11	12VDC	10.5	LiFeP04	38 AH
KCUA11H	12VDC	10.5	LiFeP04	76 AH
Battery Charger	120VAC	3.0	-	-

INITIAL SETUP:

1. Remove all packing material from inside the cabinet
2. Clean and sanitize the interior of the cabinet. See Cleaning Instructions on page 4.
3. Install all shelf angles on posts
4. Ensure condensate pan is secured in the back pocket of the unit with supplied screw, and make sure drain tube is situated so it will drain into it.
5. Plug “power supply battery charger” into wall receptacle.
6. Plug in 12V connector into back of KoldCube, making sure red connects to red and black connects to black. Either inlet connector can be used.
7. Move the switch on the power supply battery charger to ON (I). The light on the charger will eventually turn red, signifying the battery is charging.

WARNING: *USE ONLY SUPPLIED BATTERY CHARGER OR CONNECT TO 12VDC SYSTEM NOT EXCEEDING 14.4VDC. REPLACE CHARGER WITH ONLY GENUINE CRES COR PART. USING A DIFFERENT BATTERY CHARGER VOIDS WARRANTY AND COULD DAMAGE EQUIPMENT OR CREATE A POTENTIALLY HAZARDOUS SITUATION.*

FIRST TIME OPERATION:

1. Keep unit plugged into wall receptacle, charging.
2. If charger has been plugged in for over 4 hours (with unit powered OFF) and battery monitor does not read 100%, it has become un-sync’d. Hold the + and – buttons together for 3 seconds to re-sync to 100%.
3. Press power switch ON. Switch will illuminate and thermometer will turn on.
4. Thermometer displays internal cabinet temperature.
5. Pre-cool the cabinet for at least 1 hour before loading food.

NOTE: *DO NOT PUT HOT FOOD INTO COLD CABINET. UNIT IS INTENDED FOR COLD FOOD ONLY TO BE PLACED INTO REFRIGERATED ZONE.*

NORMAL OPERATION:

1. Thermometer will always display the temperature representing the warmest zone of the cabinet.
2. Temperature setpoint has been pre-set at the factory for optimal operation of the cabinet. Internal controls will self-regulate the temperature – no adjustment is necessary.

(Continued on Page 3)

OPERATING INSTRUCTIONS, *Continued*

3. To view the max and minimum temps the cabinet has been at, follow the below instructions:
 - a. Press SET button
 - b. “HI” will be displayed on screen
 - c. Press SET button
 - d. Highest value seen will be displayed on screen
 - e. Press SET button
 - f. “Lo” will be displayed on screen
 - g. Press SET button
 - h. Lowest value seen will be displayed on screen
 - i. Press SET button to go back to normal
4. This unit is intended to be used as temporary cold storage/transport. It is designed to operate whether plugged in or not. For best results, it is recommended to always pre-cool the cabinet before use, and to keep unit plugged in and charging while pre-cooling.
4. If storing for a long period of time, it is recommended to charge unit fully before storing unplugged. Before using again, charge battery to 100%.
5. This unit is designed for air defrost. Under normal conditions, there is no need for a defrost cycle, and the evaporator condensate will drain into the condensate pan in the back pocket of the unit.
6. Remove the condensate pan in the rear pocket of the unit and drain daily or as needed. Do not allow the pan to overflow.
7. If unit is located in an extremely hot and humid climate AND subject to continuous usage AND the door is open an abnormal amount, a manual defrost may need to be executed. In the unlikely case this happens, remove all PHF (any food items that must stay refrigerated) and place in another refrigerator. Turn the unit off, open the door, and allow it to warm up for 30 minutes. The unit is now ready to operate again normally.

BATTERY:

1. Different operating conditions affect battery life (ambient temperature, pre-cool amount, food load, usage factor, etc.) but in general, refer to table below for expected battery life per charge:

KCUA11	3-4 Hours
KCUA11H	6-8 Hours

2. Charge time will vary on operating conditions and ambient temperature, but in general, refer to the table below for expected charge times:

KCUA11	Cabinet ON	5 Hours
	Cabinet OFF	2-2.5 Hours
KCUA11H	Cabinet ON	10 Hours
	Cabinet OFF	4-5 Hours

3. For longest battery life, it is recommended to not let the battery charge go below 10%. It is OK to leave unit plugged in after it has reached 100% charge – battery charger will settle on a voltage that is safe to leave for a period of time.

NOTE: *EVAPORATOR FAN OPERATES ONLY WHEN DOOR IS CLOSED. IF DOOR IS KEPT OPEN FOR AN EXTENDED PERIOD OF TIME, THE RISK OF ICE FORMING ON EVAPORATOR COIL INCREASES.*

TO TURN UNIT OFF:

1. Press power switch OFF.

KoldCube [®] Refrigerated Cabinet	FL-2379
Rev. 1 (7/19)	Page 4 of 9



5925 Heisley Road • Mentor, OH 44060-1833

MAINTENANCE INSTRUCTIONS

HOW TO CLEAN THE CABINET:



WARNING

BEFORE cleaning the cabinet:

1. Unplug cord from wall.
 2. Do NOT hose cabinet with water.
 3. Do NOT get water into bottom compartment.
 4. Do NOT use abrasives or harsh chemicals.
- Wipe up spills as soon as possible.
 - Clean regularly to avoid heavy dirt build-up.

Cleaning Hints:

1. Use the mildest cleaning procedure that will do the job.
2. Always run in the direction of polish lines to avoid scratching the surface.
3. Use only a soft cloth, sponge, fibrous brushes, plastic or stainless steel pads for cleaning and scouring.
4. Rinse thoroughly with fresh water after every cleaning operation.
5. Always wipe dry to avoid water marks.

	Soil	Cleaner	Method
CABINET Inside and Outside (Stainless Steel)	ROUTINE CLEANING	Soap, Ammonia, or mild *detergent and water.	1. Sponge on with cloth. 2. Rinse with water. 3. Wipe dry.
	STUBBORN SPOTS AND STAINS	Mild abrasive made for stainless steel.	1. Apply with damp sponge or cloth. 2. Rub lightly.
	GREASE, OIL	Chemical oven cleaner for stainless steel.	Follow oven cleaner manufacturer's directions.
	HARD WATER SPOTS & SCALE	Vinegar	1. Swab or wipe with cloth. 2. Rinse and dry.
<i>*Mild detergents include soaps and non-abrasive cleaners.</i>			

KoldCube ³ Refrigerated Cabinet	FL-2379
Rev. 1 (7/19)	Page 5 of 9

MAINTENANCE INSTRUCTIONS

MAINTENANCE:

Note: The refrigerator is shipped fully charged. No changes to the refrigerant system are necessary.



Take extra caution not to dent or pierce the unit on the back side or top. Damage to the refrigerant and battery systems could result, causing a potentially dangerous situation.

TECHNICAL SPECIFICATIONS

Configuration	Refrigerant Type	Charge Size (oz)	Example Operating Pressure (High Side)	Example Operating Pressure (Low Side)
KCUA11/H	R134A	8	150	25
KCUA11/H	R513A	8	115	23

NOTE: When servicing unit, refrigerant MUST be replaced ONLY with that listed on spec plate of unit. Do not attempt to retrofit a different refrigerant than that which came in the unit from the factory.

KoldCube [®] Refrigerated Cabinet	FL-2379
Rev. 1 (7/19)	Page 6 of 9



5925 Heisley Road • Mentor, OH 44060-1833

MAINTENANCE INSTRUCTIONS TROUBLE-SHOOTING GUIDE

TROUBLE-SHOOTING GUIDE

Unit Condition:

Unit is plugged in. Switch is *ON*.

Failure	Probable Cause	Fix
1. Pans do not fit perfectly in transport angles	1a. Misalignment	1a. Add or remove shim kit.
2. Power light off, cabinet does nothing	2a. Battery not charged.	2a. Charge battery.
3. Thermometer value is flashing.	3a. Cabinet is outside normal temperature.	3a. Allow cabinet to come to temp.

Cabinet is Not Cooling:

Failure	Probable Cause	Fix
1. Compressor not operating.	1a. Sensor issue.	1a. Fix or replace.
	1b. Wiring issue.	1b. Fix or replace.
	1c. Compressor overheated.	1c. Wait to cool.
	1d. Component failure.	1d. Replace.
2. Evaporator fans not operating.	2a. Door open.	2a. Close door.
	2b. Wiring issue.	2b. Fix or replace.
	2c. Door switch failure.	2c. Fix or replace.
	2d. Evaporator fan failure.	2d. Replace.
3. Condenser fan not operating.	3a. Wiring issue.	3a. Fix or replace.
	3b. Condenser fan failure.	3b. Replace.
4. Refrigerant loss.	4a. Leak.	4a. Check system for leaks, recharge.

NOTES:

1. For replacement of the electrical parts, refer to our list of authorized service centers (FL-1400).

REPLACEMENT PARTS

Include all information on nameplate when ordering parts

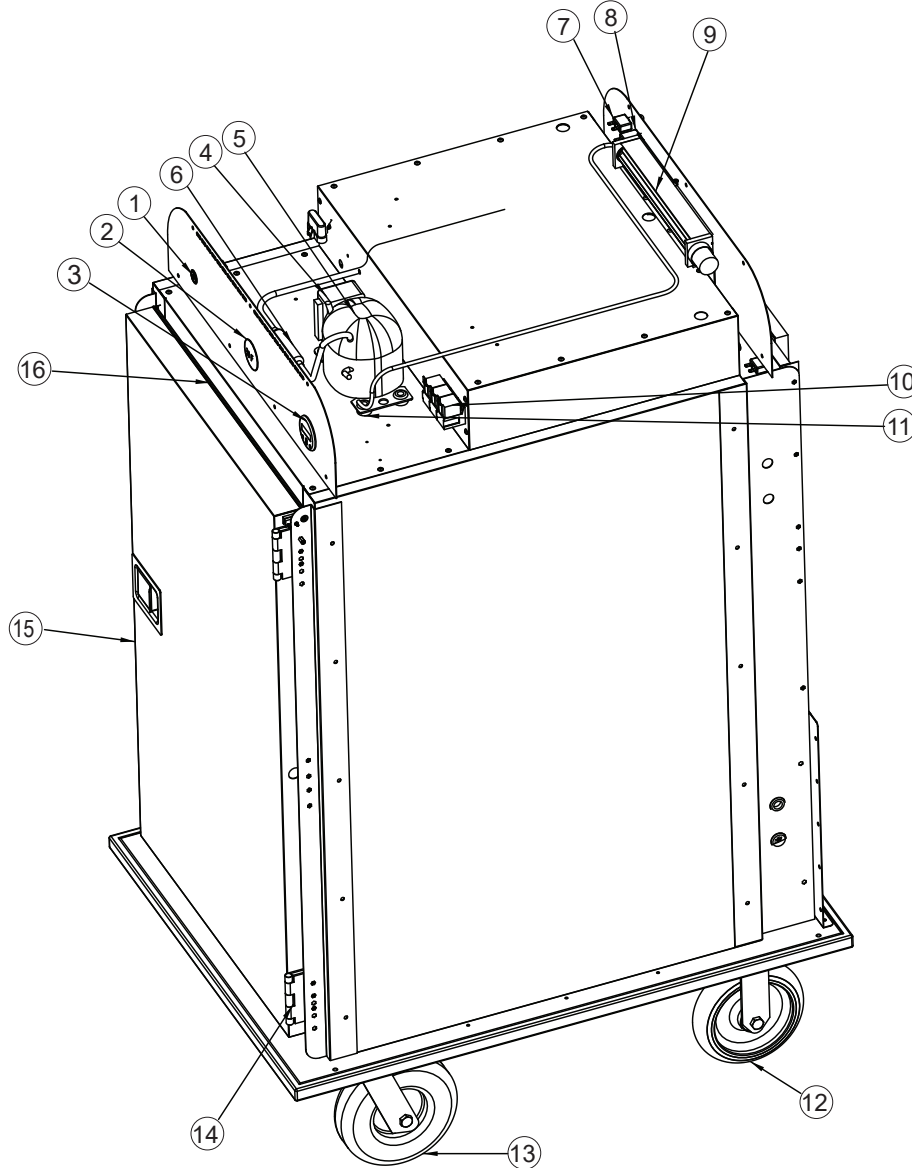

#	Description	KCUA11	KCUA11H	#	Description	KCUA11	KCUA11H
1	Power switch	0808-130	0808 130	9	Condenser fan	0769-222	0769-222
2	Thermometer (incl. sensor)	5238-036	5238 036	10	Relay 30A (ea)	0857-142	0857-142
3	Battery monitor	7037-015-01	7037 015 02	11	Compressor mount kit	0854-057	0854-057
4	Compressor driver	0848-120	0848-120	12	Caster, rear	0569-341-R	0569-341-R
5	Compressor	0854-056	0854-056	13	Caster, front	0569-341-B	0569-341-B
6	Accumulator	0854-044	0854-044	14	Hinge kit	0519-110-K	0519-110-K
7	Circuit breaker 3A	0807-167	0807-167	15	Door assembly	1221-685-IN	1221-685-IN
8	Circuit breaker 15A	0807-168	0807-168	16	Door gasket	0861-300	0861-300

KoldCube ³ Refrigerated Cabinet	FL-2379
Rev. 1 (7/19)	Page 8 of 9



5925 Heisley Road • Mentor, OH 44060-1833

REPLACEMENT PARTS

Include all information on nameplate when ordering parts

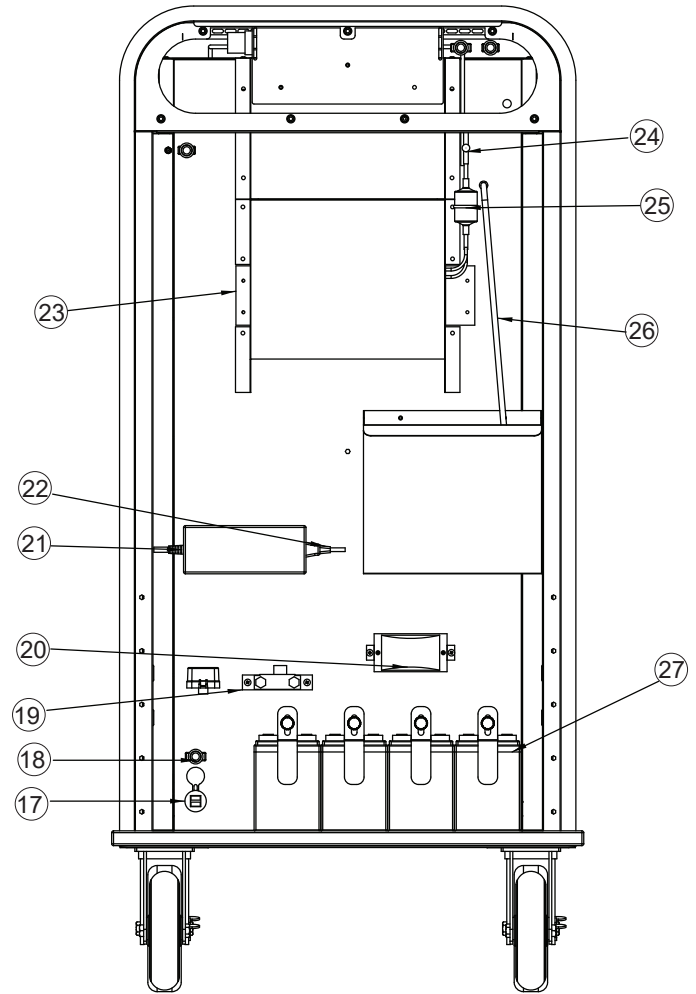
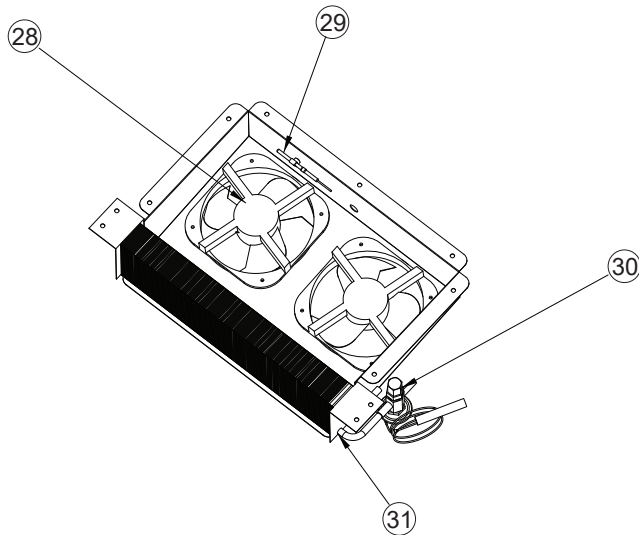

#	Description	KCUA11	KCUA11H	#	Description	KCUA11	KCUA11H
17	Battery charger jack	7037-014	7037-014	28	Evaporator fan (ea)	0769-221	0769-221
18	Circuit breaker 30A	0807-169	0807-169	29	Thermistor	0848-121	0848-121
19	Shunt	7037-015-01	7037-015-02	30	Thermal expansion valve	0854-058	0854-058
20	Solar regulator	7037-002	7037-002	31	Evaporator coil	1416-076	1416-076
21	Battery charger	7037-013	7037-013				
22	Power cord - battery charger	7037-013-01	7037-013-01		Wire kit	5813-050	5813-050
23	Condenser coil	1416-075	1416-075		Add'l wire kit for H model battery	N/A	5813-050-01
24	Service Tee	1109-038	1109-038		PV connector +	0807-193	0807-193
25	Drier	0858-008	0858-008		PV connector -	0807-194	0807-194
26	Drain tube	0913-148	0913-148		20W solar panel	7037-019	7037-019
27	Battery (ea)	7037-016	7037-016		Bluetooth dongle, battery monitor	7037-018	7037-018

WIRING DIAGRAM

