

INSTALLATION and OPERATING INSTRUCTIONS for INFRA-RED FOOD WARMERS with FLEXIBLE ARMS, IFW60GL or HEAT-N-SERVE MODELS, IFW61GL

ELECTRICAL SPECIFICATIONS:

VOLTS	WATTS	AMPS	HERTZ	PHASE	NEMA
120	250	2	60	1	5-15
240	275	1.1	60	1	6-15

These models are listed by *The National Sanitation Foundation* under Standard 4

HOW TO INSTALL:

IFW-60-GL with Base Clamp

These units can be attached to any flat surface on which the clamp-jaws can be fastened.

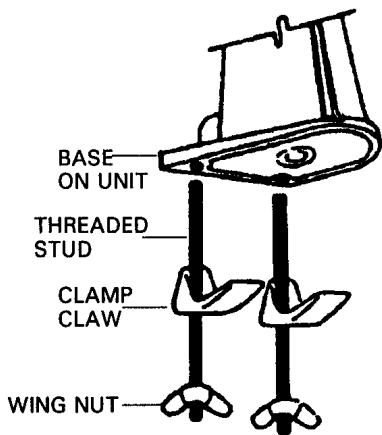

HOW TO INSTALL:

IFW-60-GL to the wall with Accessory Bracket

Fasten bracket securely to wall or any suitable vertical surface and plug cord into proper outlet.

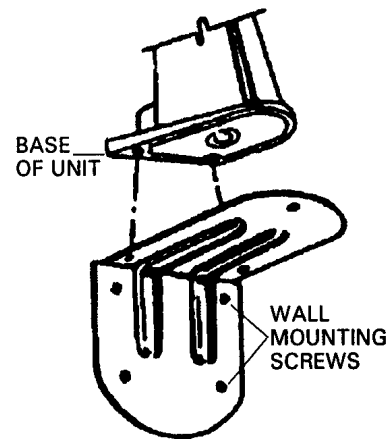

HOW TO CLEAN:



1. Let warmer cool before cleaning.
2. Unplug warmer from wall outlet.
3. Do NOT put warmer in water or spray with water.

Wipe off grease and food splatters **immediately** with a damp cloth and dish detergent.

CAUTION: Hood may be **HOT!**

EVERYDAY:

Wipe warmer hood, plastic-coated arm, and base with a damp cloth.
 Do not use gritty cleaners unless really necessary.

HOW TO INSTALL:
IFW-61-GL to Cutting Board

Note: The bracket and fasteners are packed with the cutting board.

1. Screw the bracket (Item 1) to the IFW base (Item 2) with three flat-head screws (Item 3).
2. Put the IFW unit with bracket on the cutting board and fasten with wing screw (Item 4) into the side and with thumb screw (Item 5) from underneath the cutting board. Tighten securely.

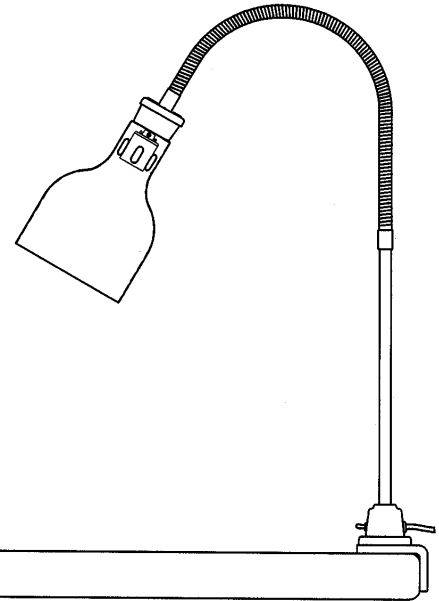
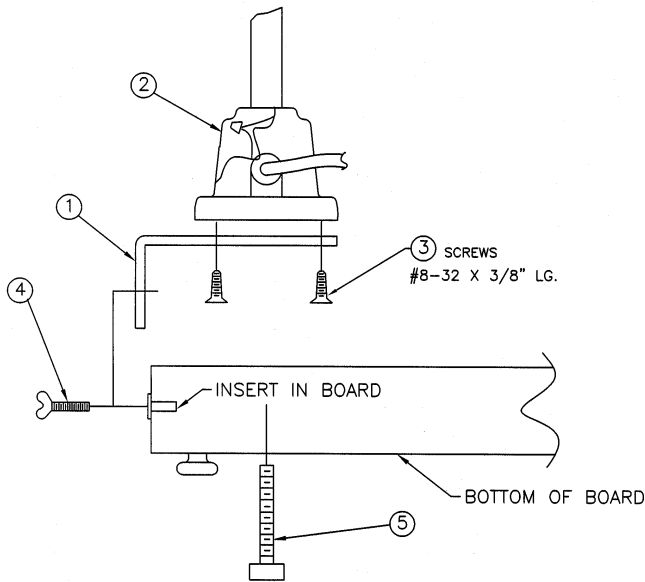

REPLACEMENT PARTS:

DESCRIPTION	CMP PART#
Toggle Switch Seal.....	0808-051
Switch (120V).....	0808-002C
Switch (240V).....	0808-122
Power Supply Cord (120V).....	0810-042
Power Supply Cord (240V).....	0810-139
Clamp Bracket Assembly.....	0843-001
Lamp, Red (250 Watts).....	0820-001
Lamp, White (250 Watts).....	0820-033
Lamp, Red (275 Watts, 240V).....	0820-014
Bun Pan, 18" x 26".....	1038-043
Cutting Board Assembly.....	1415-004
Bracket Kit (IFW61GL).....	0553-576
Wall Bracket (IFW60GL).....	0844-002