

OPERATING and MAINTENANCE INSTRUCTIONS HC2UA11 Fire-N-Ice Hot Cabinet

HOW TO INSTALL THE UNIT:

1. Remove all paper and packing materials from the inside of the cabinet and install angles into posts.
2. Remove protective material from the door of the cabinet.
3. Place the cabinet in a well-ventilated area on level floor or ground.
4. DO NOT block the flue vent located at the upper rear of the cabinet.



MAINTENANCE INSTRUCTIONS

WARNING

BEFORE cleaning the cabinet, allow cabinet to cool.

Cleaning hints:

1. Wipe up spills as soon as possible.
2. Clean cabinet daily to avoid heavy dirt build-up.
3. Make a test spot with cleaner:
 - a) Follow manufacturer's directions on cleaner.
 - b) Do not mix cleaners.
 - c) Avoid drips and splashes.

CAUTION

1. Do **NOT** use abrasives (steel wool) or harsh chemicals (chlorine, bromine, iodine or ammonia).
2. Do **NOT** use a water sprayer (pressure sprayer) to clean the cabinet.
3. Do not use Cres Clean on label or plastic materials.

HOW TO CLEAN THE UNIT:

	Soil	Cleaner	Method
OUTER CABINET (Powder Coat and vinyl)	WEEKLY, OR AS NEEDED	Mild detergent and warm water.	1. Wipe with clean, soft cloth. 2. Rinse well. 3. Dry gently.
CABINET Inside and Door (Stainless Steel)	DAILY CLEANING	Mild detergent and hot water.	1. Sponge on with cloth. 2. Rinse with water. 3. Wipe dry.
	STUBBORN SPOTS AND STAINS	Mild abrasive made for stainless steel.	1. Apply with damp sponge or cloth. 2. Rub lightly. 3. Rinse with water and wipe dry.
	BURNT-ON FOODS OR GREASE	Chemical oven cleaner for stainless steel.	Follow oven cleaner manufacturer's directions.
	HARD WATER SPOTS and SCALE	Vinegar	1. Swab or wipe with cloth. 2. Rinse and dry.

**Mild detergents include soaps and non-abrasive cleaners.*

Holding Cabinet	FL-2397
Rev. 0 (04/17)	Page 2 of 5

OPERATING INSTRUCTIONS

CANNED FUEL USE:

1. Make sure both vents in the bottom of the unit are open! (See Detail A below)
2. Load product to be kept warm.
3. Remove canned fuel holders, install canned fuel light and reinsert.

NOTE: 2 cans of canned fuel is the maximum amount recommended.

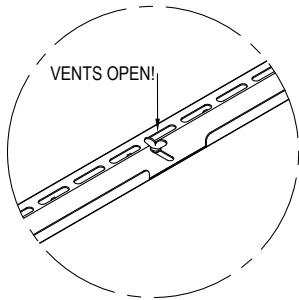

DETAIL A

DRY ICE USE:

1. Make sure both vents in the bottom of the unit are closed! (See Detail B below)
2. Load product to be kept cold/frozen.
3. Remove ice tray from unit, load with dry ice and reinsert. Up to 30 lbs. "Cheese Curl" type recommended, for ease of loading.

WARNING Handle dry ice and filled dry ice tray with gloves only!

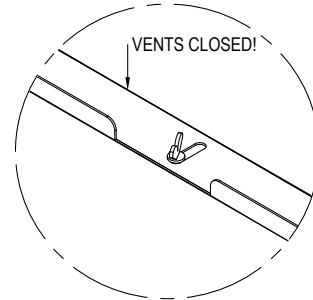

DETAIL B

For Cold Holding

The Fire-N-IceCube uses dry ice to keep food cold or frozen outdoors. Use the chart below to determine how much dry ice to use. Every 5 pounds of dry ice used provides approximately two hours of holding time. For example, if your outdoor event was 8 hours long, you might want to have 20 pounds of dry ice on hand in a cooler. If you do not require your product to be frozen, 2-3 pounds of dry ice should keep it sufficiently chilled for an extended amount of time.

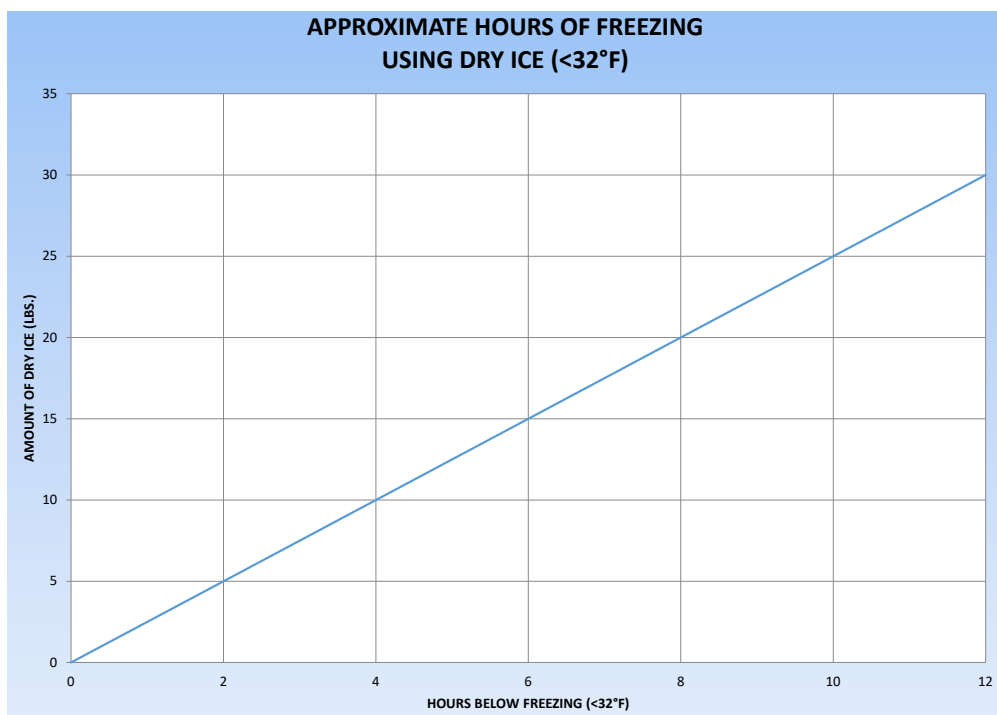

Holding Cabinet	FL-2397
Rev. 0 (04/17)	Page 3 of 5

OPERATING INSTRUCTIONS (continued)

For Hot Holding

Use canned fuel in the Fire-N-IceCube to heat and hold food products. You may use one or two cans of fuel in your cabinet, depending on your desired length of hold time and required temperature. One can maintains an average temperature of 160-180°F for up to three hours of hold time. Two cans achieve an average of 240-260°F for the same length of time. Use the provided charts to get an idea of how many cans will best suit your needs.

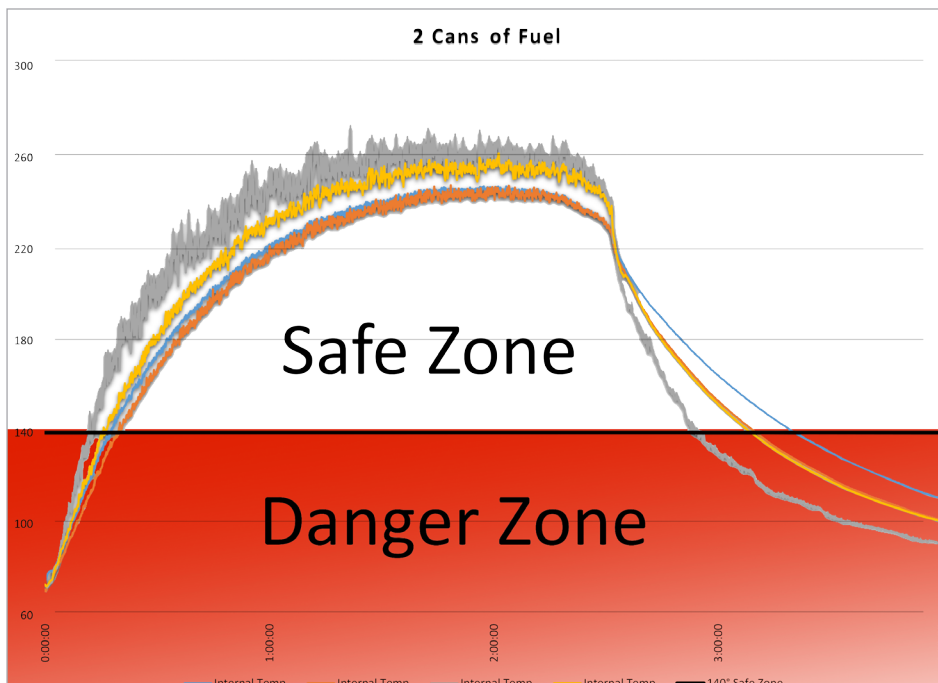
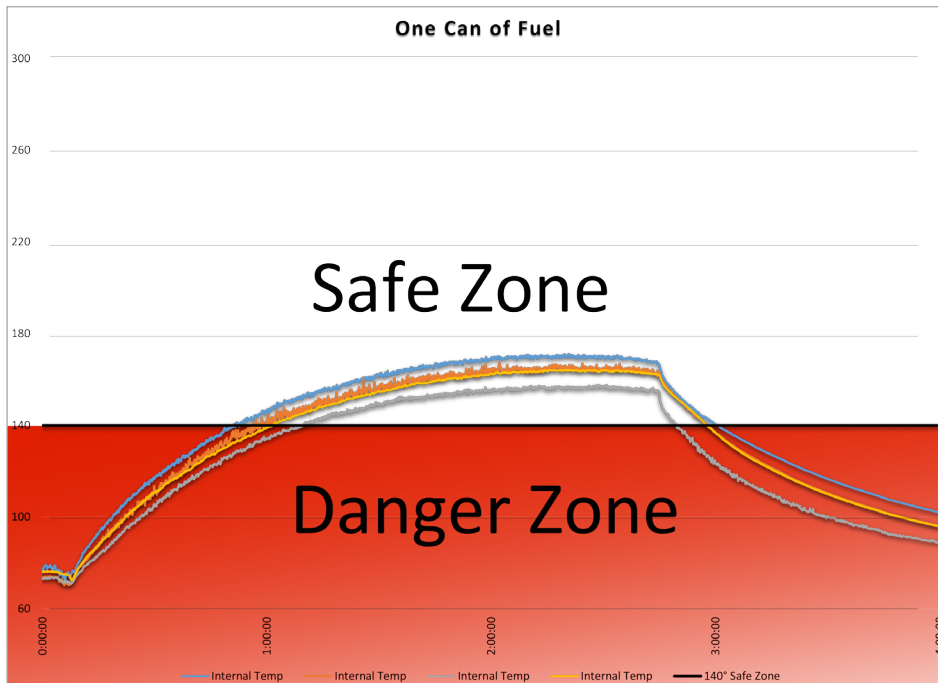

Holding Cabinet	FL-2397
Rev. 0 (04/17)	Page 4 of 5

FREQUENTLY ASKED QUESTIONS (FAQ)

What is Canned fuel?

Canned fuel is made from denatured and jellied alcohol. It is designed to be burned directly from its can. Canned fuel usage provides 2+ hours of hot holding time when used in the Fire-N-IceCube. Cans are changeable for additional hold time, and are an inexpensive and a readily available fuel source.

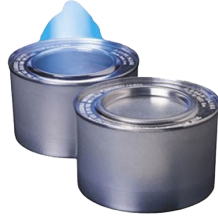

Where do I buy canned fuel?

Canned fuel is available at many large retailers as well as foodservice dealers.

How many cans of fuel will I need?

It depends on the length of hold time you're trying to achieve, and the level of heat you need to maintain. Typically, one or two cans is all you'll need. See the reverse side of this sheet to determine how many cans to use.

What are the safety concerns with canned fuel?

Canned Ethanol Gel is a very safe product, however, be aware that the can gets hot when the product is lit. As it is an open flame you'll want to make sure any flammable objects (napkins, drapes, table decorations, etc) are well out of the way.

Is it safe to use canned fuel indoors?

Yes, it is as safe to use indoors as it outdoors. Always use in a well-ventilated area and be aware the can gets hot when the product is lit. The Fire-N-IceCube is designed for outdoor use. Check your local codes to be on the safe side before using canned fuel indoors.

How long can I store my canned fuel?

Technically there is no expiration date for canned fuel. However, we recommend replacing any unused cans of fuel after 2 years (from date of purchase).

What is Dry ice?

Dry ice is the solid form of carbon dioxide (CO₂). It is called "dry ice" because it does not melt like wet ice. Instead, dry ice converts into carbon dioxide gas. Because dry ice is extremely cold (-109°F/-78.5°C), non-toxic, and completely dry, it is commonly used as a refrigerant to ship and hold frozen food.



Where do I buy dry ice?

Dry ice can be found at more than 4500 locations nationwide, including stores like City Market, Food 4 Less, Fred Meyer, Meijer's, Kroger, Publix, Safeway, Wal-Mart, Winn-Dixie, also distributors such as Airgas and Continental Carbonic.

What are the safety concerns with dry ice?

Dry ice converts to carbon dioxide gas (CO₂) when exposed to the air, so be sure to store it in an insulated container. Always use dry ice in a well-ventilated, open space. While you can touch dry ice without immediately being burned, we still encourage you to use gloves, tongs or a towel when handling it as it can irritate skin if direct contact is made for more than 7-10 continuous seconds.

How much dry ice will I need?

It depends on the length of hold time you're trying to achieve. See page 2 to determine the proper amount of dry ice to use.

Is dry ice toxic?

No, it's not. Dry ice is just the solid state of carbon dioxide. This is what makes it excellent for refrigerating food products! That being said, you still should not consume dry ice.

How do I dispose of any unneeded dry ice?

Place any unused dry ice in an open, well-ventilated area inside a cooler or paper bag or just set it outdoors away from children or pets. It will dissipate in a short amount of time.

Holding Cabinet	FL-2397
Rev. 0 (04/17)	Page 5 of 5

REPLACEMENT PARTS

Include all information on nameplate when ordering parts

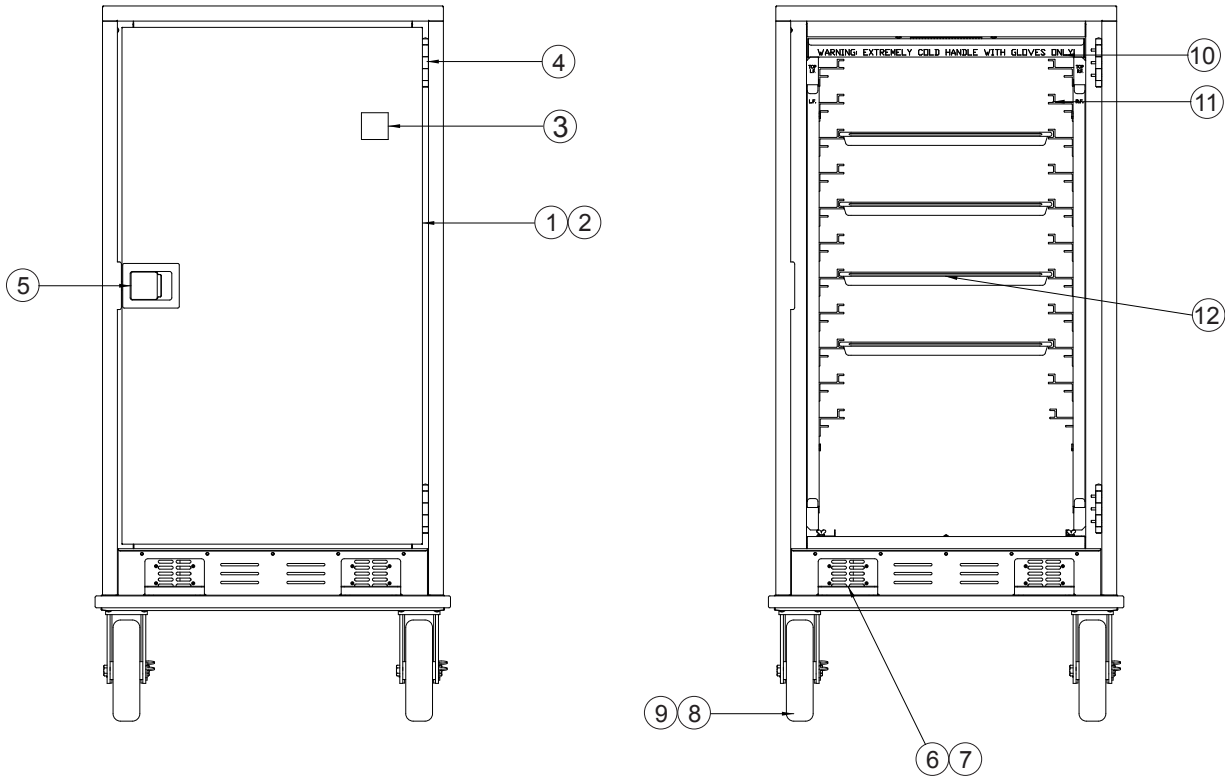

ITEM DESCRIPTION

- | | |
|----|------------------------------|
| 1 | Door Assembly |
| 2 | Gasket, Door |
| 3 | Thermometer |
| 4 | Hinge (2 per kit) |
| 5 | Latch |
| 6 | Front, Sterno |
| 7 | Can Holder, Sterno |
| 8 | Casters, Rigid |
| 9 | Casters, Rigid w/brake |
| 10 | Tray, Ice |
| 11 | Angle, Transport (2 per kit) |
| 12 | Perforated Pan (18 x 26) |

PART NUMBER

- | |
|----------------------------|
| 1221-673 |
| 0861-182-K |
| 5238-039 |
| 0519-110-K |
| 1006-143-K |
| 5038-029 |
| 5069-019 |
| 0569-341-R |
| 0569-341-B |
| 5414-031 |
| 0621-367-K |
| 1017-141 |