

**OPERATING and MAINTENANCE INSTRUCTIONS**  
**For INSULATED HAND-LIFT CABINETS**  
**MODEL H-339225 and H339SS1814CBE**

**ELECTRICAL SPECIFICATIONS:**

MODELS:	Volts	Watts	Amps	Hertz	Phase	NEMA
H-339225-01 / HOT CABINET TOP	120	900	7.5	60	1	5-15
H-339225-02 / PROOFER BOTTOM	120	900	7.5	60	1	5-15
H-339SS1814CBE / HOT CABINET <u>ONLY</u>	120	900	7.5	60	1	5-15

**HOW TO INSTALL UNIT: (Figure 1)**

See FL-2211-BE (enclosed) for "Stacking Instructions".

1. Plug cord into receptacle in back of the unit.
2. Turn plug clockwise to lock.
3. Plug other end into 15-amp wall outlet.
4. Place cabinet in a well ventilated area.
5. If no casters are provided, the base must be sealed to the counter or floor with grout or caulk to maintain sanitation certification.
6. Push the switch on, turn the thermostat to No. 10 and run the unit for one hour.

**NOTE: DO NOT PUT IN FOOD!** This step is to burn off manufacturing oils and excessive adhesive.

6. Let the cabinet cool and wipe inside clean with detergent and hot water before use.

**HOW TO OPERATE UNIT: (Figure 2)**

1. Push switch "ON". Yellow light will come on.
2. Preheat cabinet for 45 minutes; the cabinet temperature is factory preset.
4. Put food into cabinet.

**To Turn Off Unit:**

Push switch "OFF". The yellow light will go off.

**NOTE:** The digital thermometer will flash if cabinet temperature is below 140°F/60°C or above 250°F/60°C.

Call the factory if you need different settings.

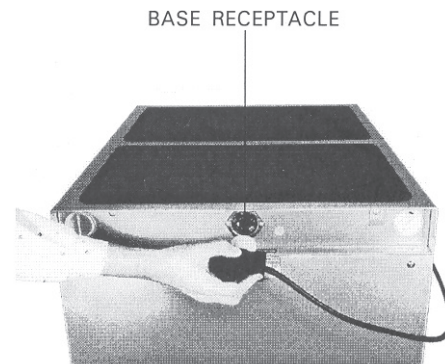

FIG. 1

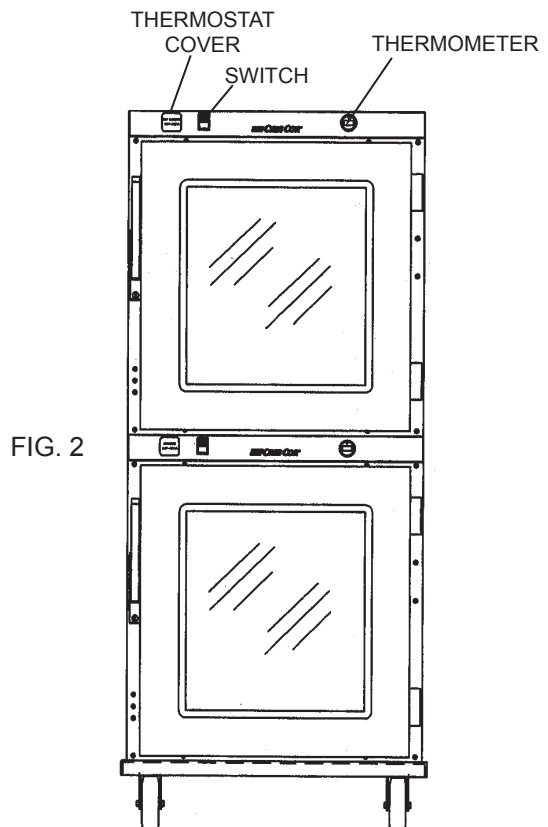

FIG. 2

## OPERATING and MAINTENANCE INSTRUCTIONS

### For INSULATED HAND-LIFT CABINETS

### MODEL H-339225 and H339SS1814CBE

## ! WARNING

### BEFORE CLEANING CABINET:

1. Remove Power Cord from cabinet.
2. Do NOT hose cabinet with water.
3. Do NOT get water on controls.
4. Do NOT use abrasives or harsh chemicals.

### Hints:

1. Wipe up spills as soon as possible.
2. Clean cabinet regularly to avoid heavy dirt build-up.
3. Make a test spot with cleaner.
4. Follow manufacturer's directions on cleaner.
5. Do not mix cleaners
6. Avoid drips and splashes.

### HOW TO CLEAN UNIT:

	SOIL	CLEANER	METHOD
<b>CABINET</b>	DIRT	Mild detergent* and hot water, or mild abrasive cleaner.	1. Use soft, damp cloth. 2. Rinse with hot water. 3. Wipe dry.
		Steam (no strong alkaline additive)	1. Rinse after steam cleaning. 2. Wipe dry.
	FINGERPRINTS, GREASE OIL	Detergent* and hot water.	1. Wipe with soft, damp cloth. 2. Rinse with hot water. 3. Wipe dry.
		Chemical oven cleaner.**	Follow oven cleaner manufacturer's directions.
		Mild abrasive cleaner. Oily or waxy cleaner.	Apply with soft, clean cloth.
	WATER SPOTS	Mild abrasive cleaner.	Wipe with damp cloth.
<p>* Mild detergents include soaps and non-abrasive cleaners</p> <p>**Be sure your cleaner is good for stainless steel for use on cabinet body; and for aluminum, for use on the rack insert (pan slides)</p>			

### HOW TO ADJUST THE DOOR LATCH:

- |  |   |
|--|---|
| <ol style="list-style-type: none"> <li>1. For <i>vertical</i> adjustment (Up and down movement):             <ol style="list-style-type: none"> <li>a. Loosen (2) screws located in magnetic strike on cabinet.</li> <li>b. Move strike up or down for alignment to magnet on latch.</li> <li>c. Tighten screws to secure</li> </ol> </li> </ol> | <ol style="list-style-type: none"> <li>2. For <i>horizontal</i> adjustment (Greater or lesser magnetic draw):             <ol style="list-style-type: none"> <li>a. Loosen four (4) screws in latch on door.</li> <li>b. Move latch forward or backward to adjust magnetic draw.</li> <li>c. Tighten screws to secure.</li> </ol> </li> </ol> |
|--|---|

## OPERATING and MAINTENANCE INSTRUCTIONS

### For INSULATED HAND-LIFT CABINETS

### MODEL H-339225 and H339SS1814CBE

#### HOW TO REVERSE DOOR HARDWARE FOR OPPOSITE HAND (Refer to Fig. 3 [hinge]):

1. Pop off hinge covers with screwdriver.
2. Remove screws from hinges to cabinet; remove door and unscrew latch strike from cabinet.
3. Remove hinges, latch and all remaining screws from the right and left side of door. Keep all screws.
4. Re-mount hinges and latch in the same hole pattern on the opposite sides of the door. Plug all extra holes with screws.
5. Remove all screws from the front sides of cabinet (not the top and bottom).
6. Hold door up to cabinet and screw hinges to the cabinet.
7. Open door and re-mount the latch strike to cabinet.
8. Plug all extra holes with screws and snap on the hinge covers.

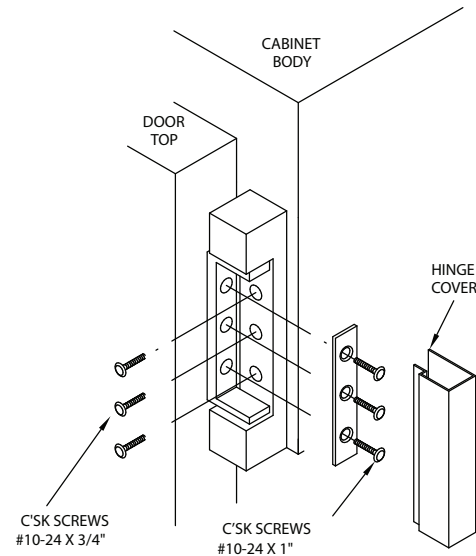

FIGURE 3



#### HOW TO ADJUST CABINET TEMPERATURE:

1. Unscrew the thermostat cover on the control panel.
2. The following knob settings are guidelines for temperatures.
  - No. 4 averages about 140°F/60°C.
  - No. 4-1/4 averages about 145°F/62°C
  - No. 6-3/4 averages about 170°F/77°C
  - No. 7 averages about 180°F/82°C.

#### TROUBLE-SHOOTING CHART

FAILURE	POSSIBLE CAUSE/CHECK
1. Unit does not heat:	1a. Thermostat turned up.
	1b. Switch is "ON".
	1c. Cord is plugged into cabinet.
	1d. Cord is plugged into outlet.
	1e. Circuit breaker/fuse for wall outlet
2. Unit will not turn off:	2a. Thermostat turned down.
	2b. Switch is "OFF"

*If cause is none of the above, refer to our list of authorized service agencies, FL-1400.*

#### REPLACEMENT PARTS

	<b>120V</b>	<b>240V</b>
Cabinet Receptacle	0713-011	0713-012
Cord Set	0810-149-01-K	0810-150-01
Switch	0808-113-K	0808-113-01-K
Heater Kit	0811-066-K	0811-066-1K
Thermostat Kit	0848-008-ACK	0848-008-ACK
Terminal Block	0852-091	0852-091
Thermometer	5238-034-K	5238-034-K
Door Latch Kit		1006-122-01 K
Strike Kit		1006-122-02 K
Hinge Kit		0519-074-K
Gasket Kit		0861-077
Casters		0569-306-K
Casters w/Brake		0569-306-BK
Transformer		0769-159-01
Door Kit		5508-093-SSK
Thermostat Cover		H339225-15-K
Rack Insert (1)		H339225-03

Insulated Hand-lift Cabinets	<b>FL-0520-BE</b>
Rev. 8 (5/13)	Page 4 of 4

## OPERATING and MAINTENANCE INSTRUCTIONS For INSULATED HAND-LIFT CABINETS MODEL H-339225 and H339SS1814CBE

### WIRING DIAGRAM

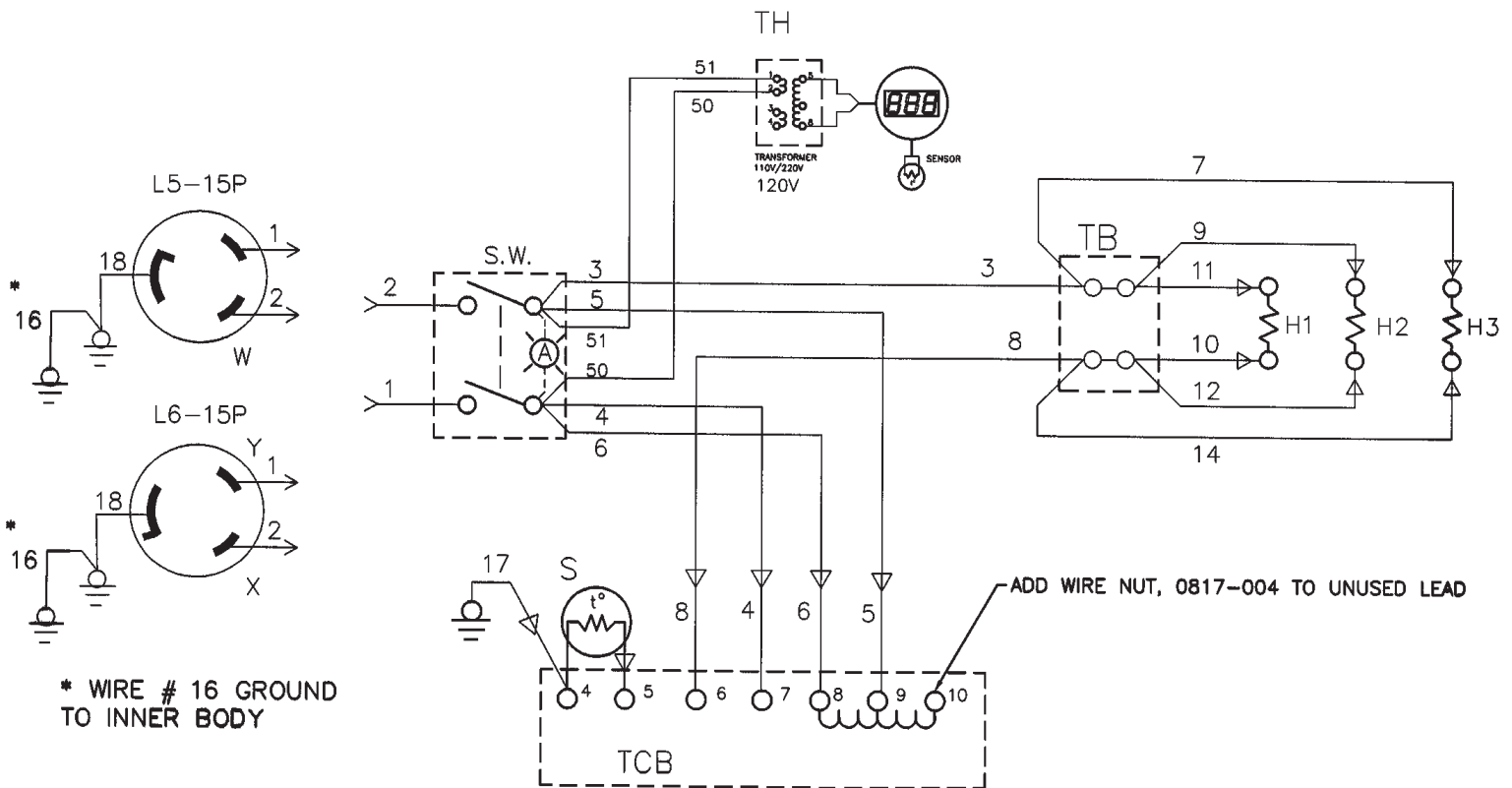

#### LEGEND

H1	HEATER - BOTTOM
H2 & 3	HEATER - RIGHT & LEFT SIDE
5-15P	PLUG (Power Cord), 120V. 15A.
6-15P	PLUG (Power Cord), 240V. 15A.
S	SENSOR - AIR
SW	SWITCH - POWER (Lighted)
TB	TERMINAL BLOCK
TCB	TEMPERATURE CONTROL BOARD
TH	THERMOMETER, DIGITAL
△	SLEEVING (12 PLACES)