

OPERATING and MAINTENANCE INSTRUCTIONS

Model H138NPS1813CLA and H138NPS1832CLA

Pass-thru Hot Cabinet Series

ELECTRICAL SPECIFICATIONS:

MODEL No.	Volts	Watts	Amps	Hertz	Phase	NEMA
H138NPS1813CLA	120	2000	16.6	60	1	5-30P
H138NPS1832CLA	120	2000	16.6	60	1	5-30P

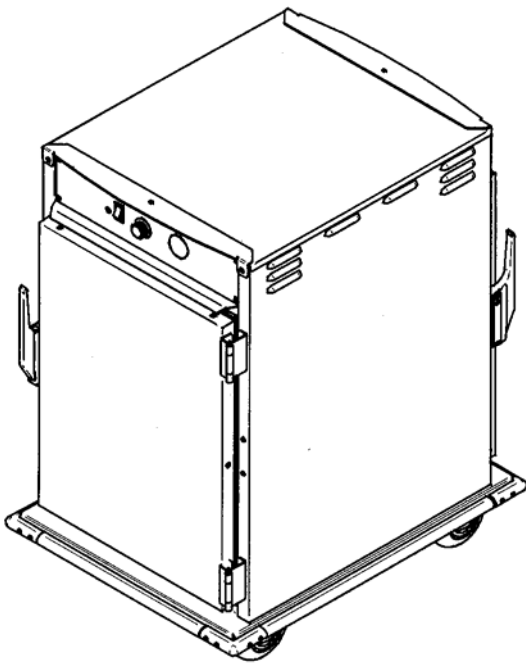
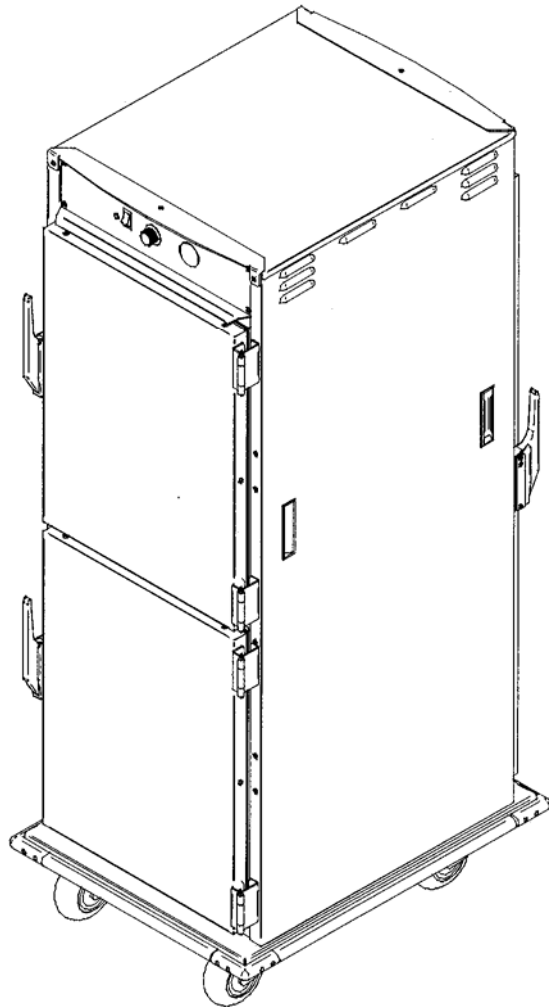
**H138NPS1813CLA****H138NPS1832CLA**

OPERATING and MAINTENANCE INSTRUCTIONS

Model H138NPS1813CLA and H138NPS1832CLA

Pass-thru Hot Cabinet Series

HOW TO INSTALL UNIT:

1. Place cabinet on level floor.
2. Plug cord into proper wall outlet.

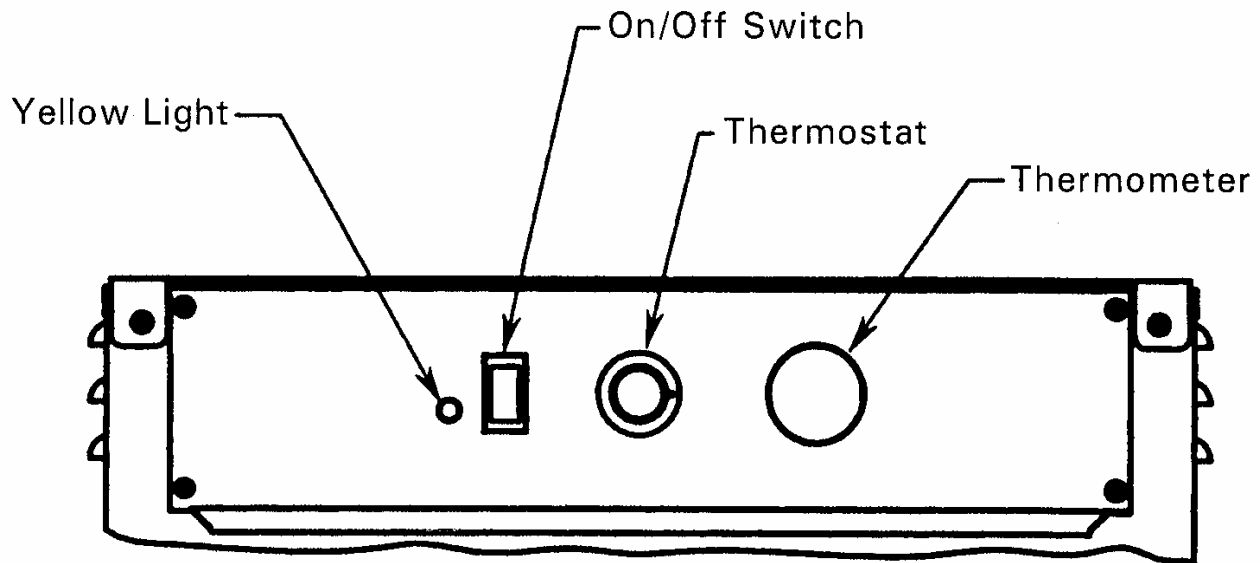

HOW TO START UNIT:

1. Turn **POWER** switch to **ON**.
The *yellow* light will turn on.
2. Turn thermostat to #10.
3. Preheat cabinet for 30 minutes.
4. Put food into cabinet.
5. Turn thermostat to #8 ½ and close door.

No. 8 setting = approx. 185°F (85°C)

No. 6 setting = approx. 160°F (71°C)

No. 4 setting = approx. 130°F (54°C)

NOTE: Proper food holding temperature is 140°F/60°C or higher.

TO TURN OFF UNIT:

Turn the **POWER** switch to **OFF**.
The *yellow* light will go out.

	WARNING RISK OF FIRE OR ELECTRIC SHOCK DO NOT OPEN	
WARNING: TO REDUCE THE RISK OF FIRE OR ELECTRIC SHOCK, DO NOT REMOVE COVER (OR BACK) NO USER-SERVICEABLE PARTS INSIDE REPAIR SHOULD BE DONE BY AUTHORIZED SERVICE PERSONNEL ONLY		

OPERATING and MAINTENANCE INSTRUCTIONS

Model H138NPS1813CLA and H138NPS1832CLA

Pass-thru Hot Cabinet Series



BEFORE CLEANING THE CABINET:

1. Allow cabinet to cool.
2. Do *NOT* use abrasives or harsh chemicals.

Cleaning Notes:

1. Wipe up spills as soon as possible.
2. Clean cabinet regularly to avoid heavy dirt build-up.
3. Make a test spot with cleaner.
4. Follow manufacturer's directions on cleaner.
5. Do not mix cleaners.
6. Avoid drips and splashes.

HOW TO CLEAN UNIT:

SOIL	CLEANER	METHOD
DIRT	Mild detergent* and hot water, or mild abrasive cleaner.	1. Use soft, damp cloth. 2. Rinse with hot water 3. Wipe dry.
	Steam (no strong alkaline additive).	1. Rinse after steam cleaning. 2. Wipe dry.
FINGERPRINTS, GREASE and OIL	Chemical oven cleaner.	Follow oven cleaner manufacturer's directions
	Mild abrasive cleaner; oily or waxy cleaner.	Apply with a soft, clean cloth.
WATER SPOTS	Mild abrasive cleaner.	1. Apply with damp cloth. 2. Rinse and dry.
<i>*Mild detergents include soaps and non-abrasive cleaners.</i>		

TROUBLE SHOOTING CHART:

FAILURE:

1. Yellow light on switch does NOT light.
2. Unit does not heat.
3. Unit gets too hot or won't shut off.
4. Blower does not work or makes noise.

POSSIBLE CAUSE:

- 1a. Circuit breaker/fuse to wall outlet is blown
- 1b. Cord is unplugged from wall outlet.
- 1c. Switch is "OFF."
- 2a. Thermostat set too low or is "OFF."
- 2b. Switch is "OFF."
- 3a. Defective electrical parts. **UNPLUG UNIT FROM WALL OUTLET:**
- 4a. Defective blower

If cause is none of the above, refer to our list of Authorized Service Centers, FL-1400.



5925 Heisley Road • Mentor, OH 44060-1833
877/CRES COR (273-7267) • 440/350-1100
Fax: 440/350-7267 • www.crescor.com

Pass-thru Holding Cabinet	FL-2254LA
Rev. 3 (9/04)	Page 4 of 5

OPERATING and MAINTENANCE INSTRUCTIONS

Model H138NPS1813CLA and H138NPS1832CLA

Pass-thru Hot Cabinet Series

REPLACEMENT PARTS:

Power Unit	0675-007
Heater, Air	0811-074
High Limit	0848-060
Thermometer	5238-030
Thermostat, Air	0848-062-K
Power Cord	0810-158-K
Power Switch	0808-116
Power Light	0766-094
Vent Fan	0769-165
Blower	0769-005
Door, Complete, Full	1221-540
Door, Complete, Half	1221-534
Door Gasket, Full	0861-246
Door Gasket, Half	0861-245
Door Hinge	0519-089
Caster	0569-290
Caster with Brake	0569-290 B
Rack Insert	1103-104
Door Latch	1006-120-01

OPERATING and MAINTENANCE INSTRUCTIONS

Model H138NPS1813CLA and H138NPS1832CLA

Pass-thru Hot Cabinet Series

Wiring Diagram

Full-Height Pass-thru Units

