



5925 Heisley Road • Mentor, OH 44060-1833

Holding Cabinet	FL-2331
Rev. 3 (3/14)	Page 1 of 7

OPERATING and MAINTENANCE INSTRUCTIONS
Models: H138NPSCMQ Series Hot Cabinet
and H138NPSCMQ-15A Series Hot Cabinet



Cabinet model number: _____

Cabinet serial number: _____

Authorized Service Agency: _____

Ph: _____ Fax: _____

Keep this manual for future reference.

Holding Cabinet	FL-2331
Rev. 3 (3/14)	Page 2 of 7

OPERATING and MAINTENANCE INSTRUCTIONS

Models: H138NPSC Series Hot Cabinet

ELECTRICAL SPECIFICATIONS:

Model No.	Volts	Watts	Amps	Hertz	Phase	NEMA
H138NPSC	120	2000	16.6	60	1	5-20P
H138NPSC-15A	120	1500	12.5	60	1	5-15P

Note: The above model numbers are basic models. They will be followed by numbers and letters.

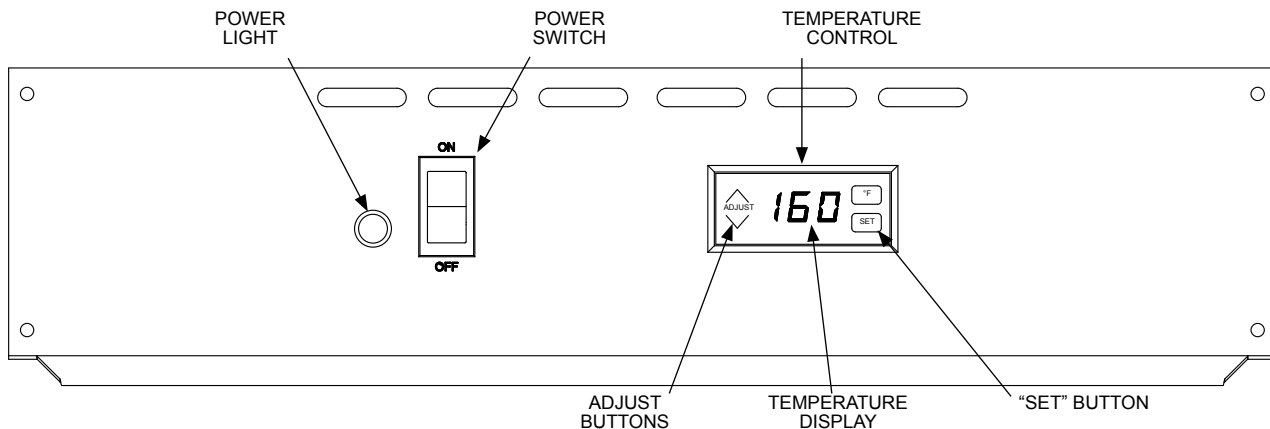

INSTALLATION:

1. Remove all paper and packing material from inside of cabinet.
2. Remove protective paper and vinyl material from outside surfaces of cabinet.
3. Place the cabinet in a well-ventilated area.
4. Place cabinet on level floor.
5. Plug cord end into proper wall outlet.

WARNING Air is **VERY HOT** when door is opened.

FIRST TIME START-UP:

1. Push the POWER switch to "ON", and run the unit for one hour.

NOTE: DO NOT PUT FOOD INTO CABINET!
This step is to burn off manufacturing oils and excess adhesive.

2. Let the cabinet cool and wipe inside clean with detergent and hot water before first use.

HOW TO HOLD:

1. Push POWER switch to "ON." Yellow POWER LIGHT will come on.
2. Push the "SET" button on the TEMPERATURE CONTROL. The TEMPERATURE DISPLAY will show "SP1" (set point 1).
3. Press "SET" again and the current set point temperature will be displayed.
4. Press the ▲▼ ADJUST buttons to adjust to the desired temperature.
5. Press "SET" to save the temperature setting.
6. Preheat cabinet for 45 minutes.
7. Put product into cabinet.

NOTE: Proper food holding temperature is 140°F/60°C or higher.

WARNING

Blower inlet guard must be in place before operating cabinet.

MAINTENANCE INSTRUCTIONS

WARNING

BEFORE cleaning the cabinet:

1. Unplug the cabinet from the wall.
2. Allow cabinet to cool.

CAUTION

1. Do **NOT** use abrasives (steel wool) or harsh chemicals (chlorine, bromine, iodine or ammonia).
2. Do **NOT** use a water sprayer (pressure sprayer) to clean the cabinet.

Cleaning hints:



1. Wipe up spills as soon as possible.
2. Clean cabinet daily to avoid heavy dirt build-up.
3. Make a test spot with cleaner:
 - a) Follow manufacturer's directions on cleaner.
 - b) Do not mix cleaners.
 - c) Avoid drips and splashes.

HOW TO CLEAN THE UNIT:

	Soil	Cleaner	Method
CABINET Inside and Outside (Stainless Steel)	DAILY CLEANING	Mild detergent and hot water.	1. Sponge on with cloth. 2. Rinse with water. 3. Wipe dry.
	STUBBORN SPOTS AND STAINS	Mild abrasive made for stainless steel.	1. Apply with damp sponge or cloth. 2. Rub lightly. 3. Rinse with water and wipe dry.
	BURNT-ON FOODS OR GREASE	Chemical oven cleaner for stainless steel.	Follow oven cleaner manufacturer's directions.
	HARD WATER SPOTS and SCALE	Vinegar	1. Swab or wipe with cloth. 2. Rinse and dry.

**Mild detergents include soaps and non-abrasive cleaners.*

Note: Gaskets are removable for cleaning.

	WARNING	
RISK OF FIRE OR ELECTRIC SHOCK DO NOT OPEN		
WARNING: TO REDUCE THE RISK OF FIRE OR ELECTRIC SHOCK, DO NOT REMOVE COVER (OR BACK) NO USER-SERVICEABLE PARTS INSIDE REPAIR SHOULD BE DONE BY AUTHORIZED SERVICE PERSONNEL ONLY		

Holding Cabinet	FL-2331
Rev. 3 (3/14)	Page 4 of 7

TROUBLE-SHOOTING

FAILURE

1. POWER LIGHT (*Yellow*) does NOT light.
2. Unit does not heat.
3. Unit gets too hot or won't shut off.
4. Blower does not work or makes noise.
5. GFCI device trips.

POSSIBLE CAUSE

- 1a. Switch is "OFF".
- 1b. Cord unplugged from wall outlet.
- 1c. Circuit breaker/fuse to wall outlet tripped/blown.
- 1d. Blown fuse
- 2a. Temperature control is set too low.
- 2b. Switch is "OFF".
- 3a. Defective electrical parts.

UNPLUG UNIT FROM WALL OUTLET.

- 4a. Defective blower.
- 5a. The insulation inside the heating element may have absorbed some moisture. This may have occurred if the cabinet has not been used for a long period of time or during shipping and storage of the cabinet. Plug the cabinet into a non-GFCI outlet and set the temperature control to its maximum. Let the cabinet run for about 1 hour to dry out the heating element from any moisture may have been absorbed. If the circuit breaker trips, call the factory Authorized service agent. After drying the heating element, plug cabinet into the GFCI receptacle; the cabinet should run properly. If the GFCI device continues to trip, call the factory Authorized service agent.

GFCI (ground-fault circuit interrupter): A GFCI receptacle is a device that de-energizes a circuit when it detects an unsafe flow of current to ground. The intention of a GFCI device is to minimize the potential for an electrical shock.

If cause is none of the above, refer to our list of Authorized Service Centers, FL-1400

Holding Cabinet	FL-2331
Rev. 3 (3/14)	Page 5 of 7

REPLACEMENT PARTS

Include all information on nameplate when ordering parts

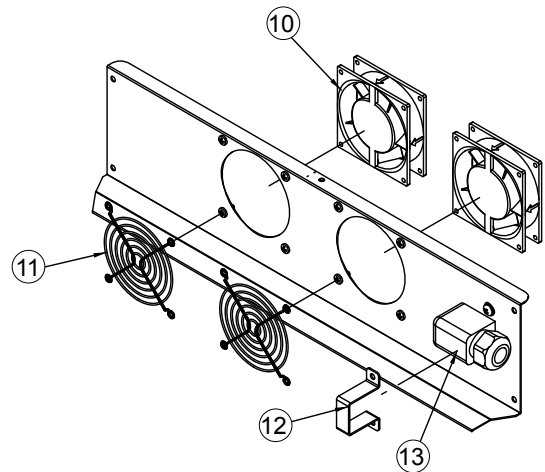
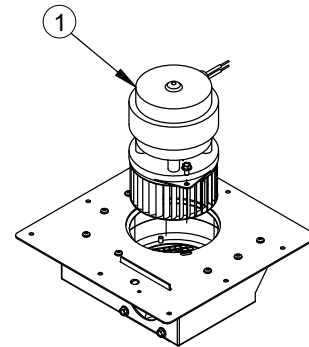
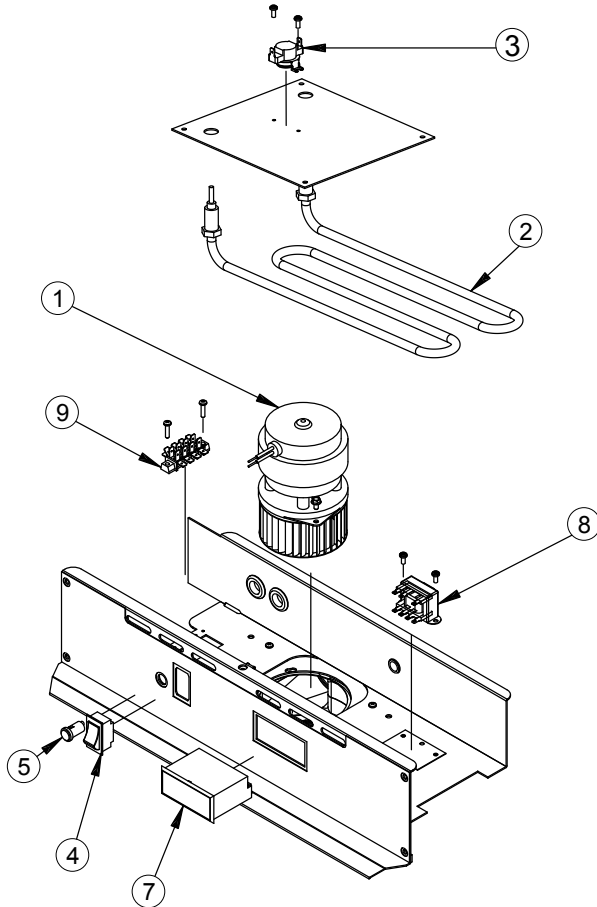

ITEM DESCRIPTION

- 1 Blower Kit
- 2 Heater Kit, Air
- 3 High Limit
- 4 Power Switch
- 5 Power Light
- Relay - Solid State (not shown)
- 7 Temperature controller
- 8 Transformer *(used with Temp controller)*
- 9 Terminal Block (4 pole)
- Terminal Block (2 pole)
- 10 Vent Fan
- Power Cord (not shown)
- Power Cord (not shown)
- 11 Fan Guard
- 12 Cord Bracket
- 13 Strain Relief 90°

120V

- 0769-180-K
- 1850 Watt 0811-022-K
- 1370 Watt 0911-289
- 0848-060
- 0808-116-K
- 0766-094
- 0857-134
- 0848-075-CC-K
- 0769-159
- 0852-093
- 0852-091
- 0769-165
- 20 Amp 0810-065-14-LK
- 15 Amp 0810-029-02
- 0769-167
- 0553-757
- 0818-095

Holding Cabinet	FL-2331
Rev. 3 (3/14)	Page 6 of 7

REPLACEMENT PARTS

Include all information on nameplate when ordering parts

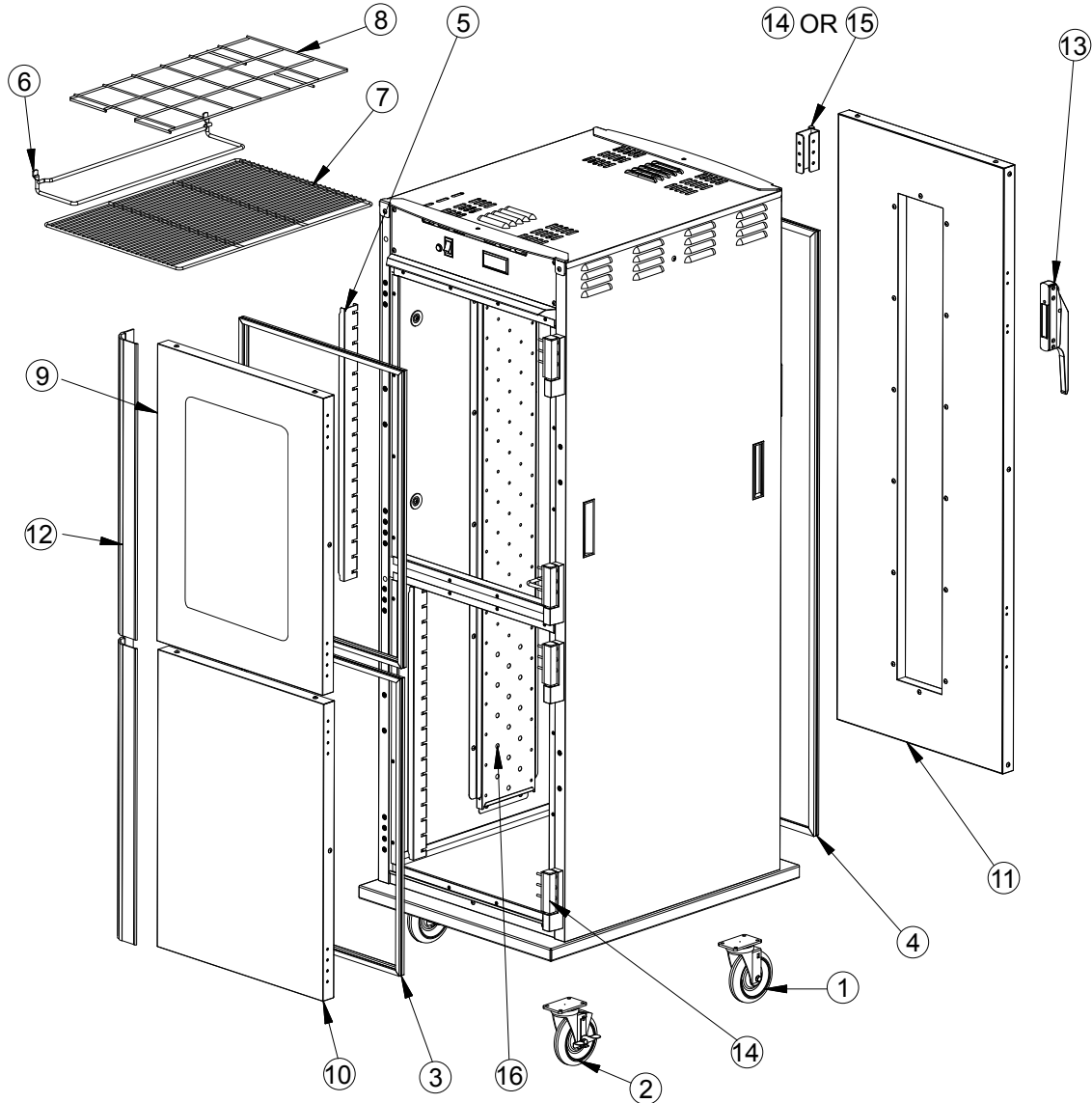

CABINET REPLACEMENT PARTS: H138NPSCDOM3

Item	Description	Part No.	Item	Description	Part No.
1	Caster	0569-306-K	11	Door, back, window	1221-629-K
2	Caster with brake	0569-306-BK	12	Handle, door	0911-111
3	Gasket, front doors	0861-245-K	13	Latch, door	1006-120-01-K
4	Gasket, back door	0861-246-K	14	Hinge Kit, lift off, set of 2	0519-114-K
5	Post, rack	0696-228	15	Hinge, butt type	0519-089
6	Angle, Wire, set of 2	0621-281-K	16	Air tunnel	0546-120
7	Wire shelf	1170-005		Door stop	0553-740
8	Wire blower inlet guard	1170-211			
9	Door, front, window	1221-610-K			
10	Door, front, solid	1221-534-K			

Holding Cabinet	FL-2331
Rev. 3 (3/14)	Page 7 of 7

WIRING DIAGRAM

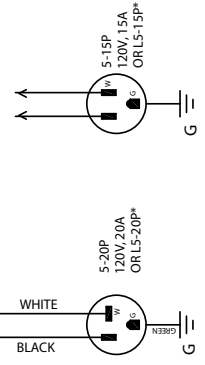
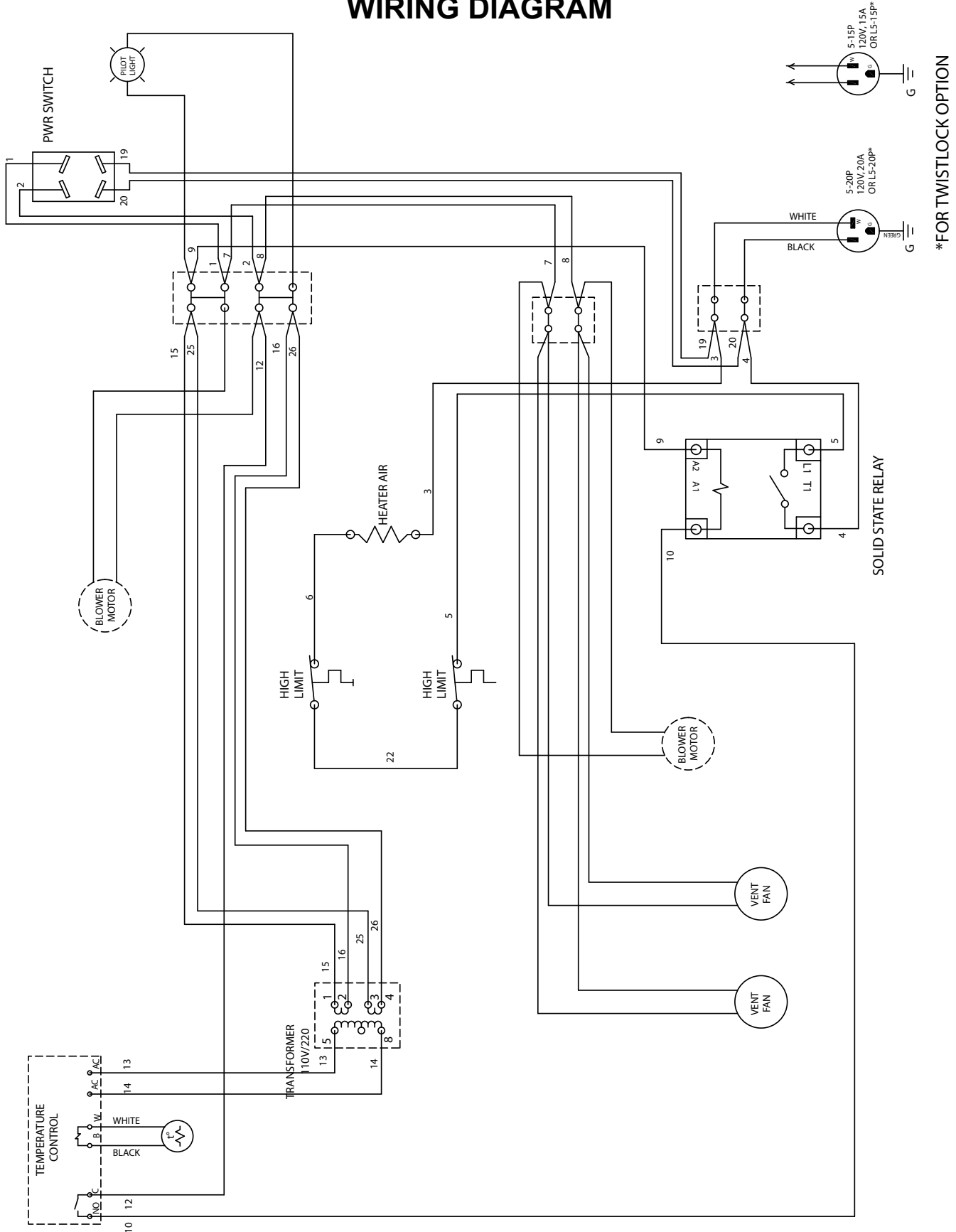

*FOR TWISTLOCK OPTION