

## OPERATING and MAINTENANCE INSTRUCTIONS

### Model: H137UA12B and H1381834B Series Hot Cabinets H137SUA12 and H138S1834 Series Hot Cabinets

#### ELECTRICAL SPECIFICATIONS:

Model No.	Volts	Watts	Amps	Hertz	Phase	NEMA
H137UA12B H137SUA12 H1381834B H138S1834	120	2000	17.3	60	1	5-20P
w/240 suffix	240	2000	8.6	60	1	6-15P
w/208 suffix	208	2000	10.0	60	1	6-15P

All models are designed for AC service.

#### HOW TO INSTALL UNIT:

1. Place cabinet on level floor.
2. Plug cord end into proper wall outlet.
3. Fill water pan with water if you want humidity.

**Note:** Pan holds 2 quarts (1.9 liters) of water.

#### HOW TO START UNIT:

1. Turn the POWER switch on. The *yellow* light will turn on.
2. Turn thermostat to #10.
3. Preheat cabinet for 30 minutes.
4. Put food into cabinet.
5. Turn thermostat to #8 and close door.

**Note:** No. 8 setting = approx. 185°F (85°C).  
No. 6 setting = approx. 160°F (71°C).  
No. 4 setting = approx. 130°F (54°C).

Proper food holding temperature is 140°F (60°C) or higher.

**Note:** The thermometer display flashes when center of cabinet is below 140°F (60°C) or above 250°F (121°C). Call the factory if you need different settings.

#### TO TURN OFF UNIT:

1. Turn the POWER switch off. The *yellow* light will go out.

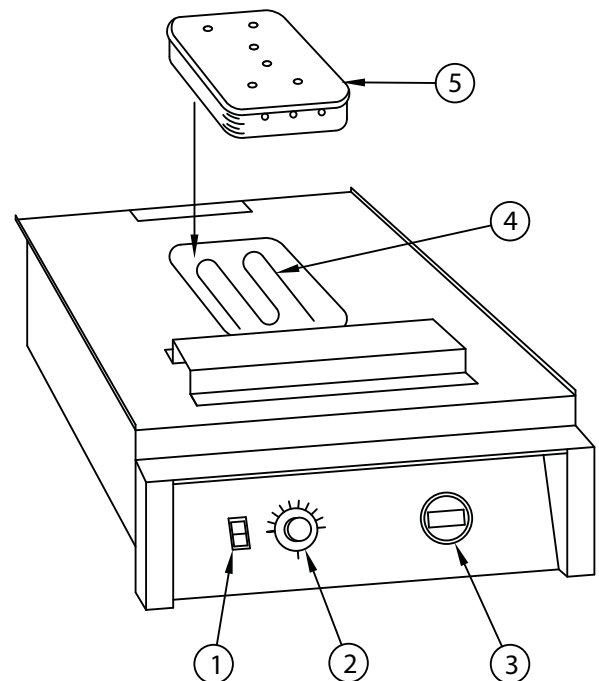

#### PARTS IDENTIFICATION

1. Power Switch
2. Thermostat
3. Temperature Display
4. Heater
5. Water Pan w/cover

Insulated Hot Cabinet	FL-1470-3
Rev. 8 (02/10)	Page 2 of 4

## OPERATING and MAINTENANCE INSTRUCTIONS

### Model: H137UA12B and H1381834B Series Hot Cabinets H137SUA12 and H138S1834 Series Hot Cabinets

#### MAINTENANCE

#### HOT UNIT REMOVAL INSTRUCTIONS:

1. Unplug power cord from wall outlet.
2. Slide the entire unit out from the front of the cabinet.

#### HOW TO CLEAN THE CABINET:

**⚠ WARNING** *BEFORE* cleaning the cabinet:

1. Allow cabinet to cool.
2. Remove Hot unit from cabinet.
3. Do NOT use abrasives or harsh chemicals.

Is your cabinet of *aluminum*, or *stainless steel* construction? Be sure your cleaner is suitable for that material.

#### Cleaning hints:

1. Wipe up spills as soon as possible.
2. Clean cabinet regularly to avoid heavy dirt build-up.
3. Make a test spot with cleaner.
4. Follow manufacturer's directions on cleaner.
5. Do not mix cleaners.
6. Avoid drips and splashes.
7. Empty water pan at least once a week.

#### HOW TO CLEAN THE UNIT:

	Soil	Cleaner	Method
Aluminum Cabinets have "B" in Model number.	DIRT	Mild detergent* and hot water, or mild abrasive cleaner.	<ol style="list-style-type: none"> <li>1. Use soft, damp cloth</li> <li>2. Rinse with hot water</li> <li>3. Wipe dry</li> </ol>
		Steam (no strong alkaline additive).	<ol style="list-style-type: none"> <li>1. Rinse after steam cleaning</li> <li>2. Wipe dry</li> </ol>
Stainless Steel Cabinets have "S" in model number.	FINGERPRINTS, GREASE and OIL	Chemical oven cleaner.	Follow oven cleaner manufacturer's directions.
		Mild abrasive cleaner. Oily or waxy cleaner.	Apply with soft, clean cloth.
	WATER SPOTS	Mild abrasive cleaner.	<ol style="list-style-type: none"> <li>1. Apply with damp cloth</li> <li>2. Rinse and dry</li> </ol>

*\*Mild detergents include soaps and non-abrasive cleaners.*

## OPERATING and MAINTENANCE INSTRUCTIONS

### Model: H137UA12B and H1381834B Series Hot Cabinets H137SUA12 and H138S1834 Series Hot Cabinets

#### TROUBLE-SHOOTING CHART:

FAILURE	POSSIBLE CAUSE
1. Yellow light does NOT light.	1a. Circuit breaker/fuse to wall outlet is blown. 1b. Cord is unplugged from wall outlet or cabinet. 1c. Switch is "OFF".
2. Unit does not get hot.	2a. Thermostat set too low or is "OFF". 2b. Switch is "OFF".
3. Unit gets too hot or won't shut off.	3a. Defective electrical parts. <b>UNPLUG UNIT FROM WALL OUTLET.</b>
4. Blower does not work or makes noise.	4a. Defective blower.
5. Excess moisture in cabinet.	5a. Do NOT add water to water pan. 5b. "Slack out" foods from oven or fryer for 5 minutes before putting in hot cabinet.

*If cause is none of the above, refer to our list of Authorized Service Centers, FL-1400.*

*Instructions for replacing parts are included in replacement parts kits.*

#### REPLACEMENT PARTS:

DESCRIPTION	120 VOLT	240 VOLT	208 VOLT
Hot Unit (Aluminum, 23" wide) .....	HU-18-671-105 .....	HU-18-671-106 .....	HU-18-671-107
Hot Unit (Stainless Steel, 23.5" wide) .....	HU-18-671-175 .....	HU-18-671-177 .....	HU-18-671-176
Water Pan, Complete .....	1017-001-03 .....	1017-001-03 .....	1017-001-03
Air Tunnel.....	6217-002 .....	6217-002.....	6217-002
Blower Kit.....	0769-180-K .....	0769-182-K .....	0769-182-K
Casters .....	0569-306 .....	0569-306.....	0569-306
Caster w/brake.....	0569-306-B .....	0569-306-B.....	0569-306-B
Door Hinge .....	0519-087-K .....	0519-087-K .....	0519-087-K
Gasket Kit, (aluminum).....	0861-203-K .....	0861-203-K .....	0861-203-K
Gasket Kit (stainless steel) .....	0861-229-K .....	0861-229-K .....	0861-229-K
Handle, black plastic .....	0911-087.....	0911-087.....	0911-087
Hi-Limit.....	0848-060 .....	0848-060.....	0848-060
Heater Kit .....	0811-022-K .....	0811-023-K .....	0811-185-K
Latch, Spring compression .....	1246-011 .....	1246-011 .....	1246-011
Power Switch.....	0808-116.....	0808-116.....	0808-116
Power Light .....	0766-094 .....	0766-095.....	0766-095
Power Cord (w/strain relief).....	0810-093 .....	0810-039.....	0810-039
Strain Relief.....	0818-048 .....	0818-057.....	0818-057
Terminal Block, Front .....	0852-091 .....	0852-091.....	0852-091
Terminal Block, Rear.....	0852-063 .....	0852-063.....	0852-063
Thermostat Kit.....	0848-062-K .....	0848-062-K .....	0848-062-K
Thermostat Knob.....	0595-061 .....	0595-061.....	0595-061
Thermometer Kit (analog).....	5238-030-K .....	5238-030-K .....	5238-030-K
Thermometer Kit (digital °F) .....	5238-034-K .....	5238-034-K .....	5238-034-K
Thermometer °F only .....	5238-034 .....	5238-034.....	5238-034
Transformer, 110/220 V. only .....	0769-159 .....	0769-159.....	0769-159
Wiring Harness .....	5812-899 .....	5812-899.....	5812-899
Door Kit.....	1221-383 .....		
Rack Insert Assembly.....	1103-088 .....		
Universal Angles .....	0692-095-K .....		

Insulated Hot Cabinet	<b>FL-1470-3</b>
Rev. 8 (02/10)	Page 4 of 4

**OPERATING and MAINTENANCE INSTRUCTIONS**  
**Model: H137UA12B and H1381834B Series Hot Cabinets**  
**H137SUA12 and H138S1834 Series Hot Cabinets**

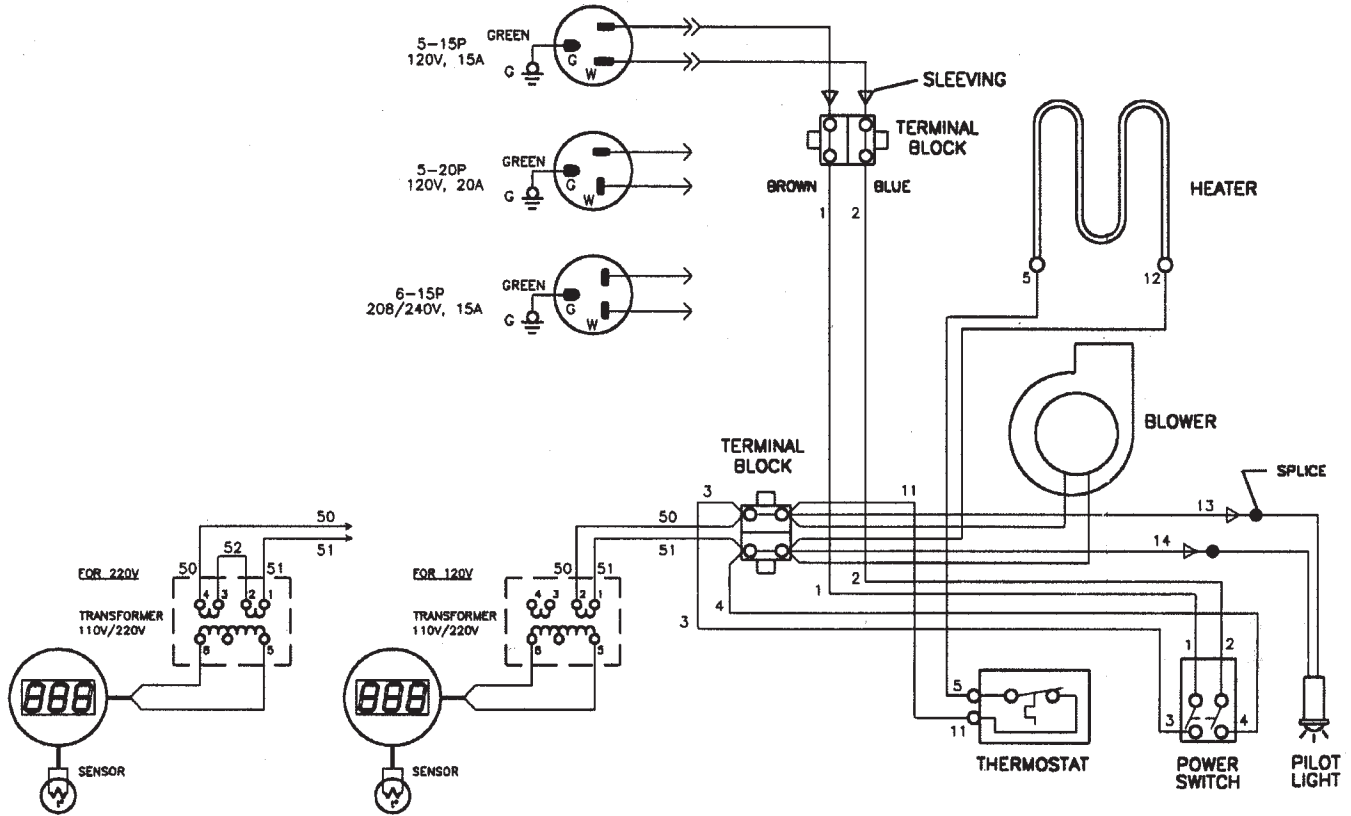

**ELECTRICAL SPECS**

Model #0671-105 Series  
 2000W, 120V, 60Hz, 1Ph

Model #0671-175 Series  
 2000W, 120V, 60Hz, 1Ph

Model #0671-106 Series  
 2000W, 240V, 60Hz, 1Ph

Model #0671-177 Series  
 2000W, 240V, 60Hz, 1Ph

Model #0671-107 Series  
 2000W, 208V, 60Hz, 1Ph

Model #0671-176 Series  
 2000W, 208V, 60Hz, 1Ph