

**INSTALLATION, OPERATION and MAINTENANCE
MANUAL for Cres Cor QUIK THERM™ RETHERM
HUMIDITY ROLL-IN OVENS WITH RACK
18,000, 12,000 or 8,000 WATTS**



RR1332WDE
RR1332WDX
RR1332WDE12K

RR1332WDE8K
RR1332WDX8K
RR1332WDX12K

Retherm Humidity Oven	FL-2392
Rev. 0 (5/16)	Page 2 of 15





TABLE OF CONTENTS

SUBJECT	PAGE
INSTALLATION INSTRUCTIONS	3
 OPERATING INSTRUCTIONS	
First Time Operation	3
How to Use Control for Cooking & Holding:	
For “-DE” Series Ovens	4
For “-DX” Series Ovens	5
“Recipes” for “-DX” Series Ovens	6
 MAINTENANCE INSTRUCTIONS	
How to Clean the Unit	7
Trouble Shooting Guide	8, 9
Oven Replacement Parts	10
Hot Unit Replacement Parts	11
Wiring Diagram for 208/240 Volt, 3 Phase	12
Wiring Diagram for 480 Volt, 3 Phase	13
Wiring Diagram for 208/240 Volt, 1 Phase	14
 SERVICE POLICY and AGENCY LIST	 FL-1400

**REGISTERING YOUR EQUIPMENT AT www.crescor.com/service/register
COMPLETING A SURVEY EARNS AN EXTRA 90-DAY LABOR WARRANTY!**

If the equipment will not go into service immediately, please indicate that on the warranty registration. Scan QR code to register your equipment today! If you need a QR reader, visit your App Store on your Smartphone or Tablet.





WARNING

RISK OF FIRE OR ELECTRIC SHOCK
DO NOT OPEN



WARNING: TO REDUCE THE RISK OF FIRE OR ELECTRIC SHOCK,
DO NOT REMOVE COVER (OR BACK)
NO USER-SERVICEABLE PARTS INSIDE
REPAIR SHOULD BE DONE BY AUTHORIZED SERVICE PERSONNEL ONLY

INSTALLATION INSTRUCTIONS

VENTING YOUR OVEN:

1. The purpose of ventilating hoods is to direct and capture smoke, grease-laden vapors, heat, odors, or fumes.
2. Low temperature equipment (maximum temperature 250°F/121°C) does not produce heat, odors, fumes, grease-laden vapors or smoke and is not required to be vented.
3. Most jurisdictions consider our low-temperature ovens (maximum temperature is 350°F/177°C) as low-heat appliances not requiring vent hoods.
4. Installation must conform with local codes. The authority having jurisdiction of enforcement of the codes will have the responsibility for making interpretations of the rules.

UNIT SPECIFICATIONS: Units below use six (6) elements (3000 watts each). Units are rated 18,000 watts.

MODEL NOS.	ELECTRICAL SPECS (AC SERVICE)			ELEC. LOAD		POWER SUPPLY REQUIREMENT ALL 3 PHASE IS 3 WIRE + GROUND			
	VOLTS	PHASES	HZ	AMPS	VOLTS	AMPS	PHASES	VOLTS	RECEPTACLE
RR1332WDE(DX)2083	208	3	60	50	208	60	3	208	15-60R
RR1332WDE(DX)2403	240	3	60	44	240	60	3	240	15-60R
RR1332WDE(DX)4803	480	3	60	22	480	30	3	480	L16-30R

UNIT SPECIFICATIONS: Units below use six (6) elements (2000 watts each). Units are rated 12,000 watts.

RR1332WDE(DX)12K2083	208	3	60	34	208	50	3	208	15-50R
RR1332WDE(DX)12K2403	240	3	60	29	240	50	3	240	15-50R
RR1332WDE(DX)12K4803	480	3	60	15	480	30	3	480	L16-30R

UNIT SPECIFICATIONS: Units below use six (6) elements (1325 watts each). Units are rated 8,000 watts.

RR1332WDE(DX)8K2081	208	1	60	40	208	50	1	208	6-50R
RR1332WDE(DX)8K2401	240	1	60	35	240	50	1	240	6-50R

All models are designed for AC Service. Model numbers may have the letters: **Z** or **S**.

HOW TO INSTALL OVENS:

1. Remove all packing material from inside and outside of oven.
2. Position oven on level floor. After shipping, you may have to adjust legs to ensure proper fit of rack into cabinet.
3. Plug power cord into proper wall receptacle.
4. **MANUAL FILL:** Fill water pan with three (3) gallons of HOT water (see **CAUTION**).
5. **AUTO FILL:** Attach water valve on back bottom of unit to water supply (see "How to Use Automatic Fill Kit" on page 7).



HOW TO CHANGE FROM °F TO °C (if needed)

1. Push the switch on; the light will come on.
2. Push and hold the "SET" button and the button in the lower left hand corner together for 5 seconds. You have now entered into the menu.
3. Scroll over the "Unit" and change it to "C", then scroll to the "END".

LOW WATER LIGHT:

MANUAL FILL: When water needs to be added to the pan, the *Low Water Light* will stay on and the humidity will not work until the pan is refilled.

AUTO FILL: If water level is low and water supply is not connected, an error code will display after a time limit.

Retherm Humidity Oven	FL-2392
Rev. 0 (5/16)	Page 4 of 15

OPERATING INSTRUCTIONS



FIRST-TIME OPERATION

NOTE: A new oven needs to “burn off” manufacturing oils and excessive adhesive before its first use. **Do NOT load food into oven until this has been done!**

1. Push the switch to on; the light will come on.

NOTE: The letters “LOtPr” (low temperature) will show on the control panel until it reaches 140°F (60°C).

2. Press the “COOK” button.
3. Turn the control knob to show 350°F. Push the knob 3 times to heat the unit. Run the unit like this for one (1) hour.
4. Turn the unit off and let cool.
5. Wipe the inside clean with detergent and hot water.

HOW TO USE THE RETHERM CONTROL:

*Push the lighted switch on the control panel; the oven will start heating and stay in HOLD mode.

*The display will read “LOTPr” (low temperature) below 140°F. (60°C.).

*Push the Air Retherm Switch to “HIGH” for retherming food; Use “LOW” for cooking.

NOTES: Preheat for one (1) hour after start up before loading the food for best results when retherming or cooking heavy loads.

If a power outage occurs or the cabinet is shut off during a cook cycle, when it is turned on again all lights on the control will flash to indicate a disruption. Control will resume the last cook cycle used. Press any button to stop the blinking.

If your model does not have a food probe, continue to section “-DE OVENS” below.

If your model has a food probe, skip to section “-DX OVENS” on page 5.

-DE OVENS:

Cooking:

1. Press the COOK button.
2. Turn the control knob to the desired cooking temperature between 180°F (82°C) and 350°F (176°C).
3. Push the knob to set the temperature.
4. The control automatically switches to allow you to set HOLD temp. (Continue to step 1 below).

Holding:

(To use as holding cabinet only, skip steps 1-4 above and press HOLD button. Complete steps 1-3 below.)

1. Turn the control knob to the desired holding temperature between 135°F (57°C) and 220°F (104°C).
2. Push the knob to set the temperature.
3. The control automatically switches to allow you to set cook time.

Setting the Timer:

1. Turn the control knob to the desired hours/minutes.
2. Push the knob to set the time.
3. The control automatically switches to PREHEAT mode and will display “PrEHt”

Continued on next page.

NOTE: This equipment is intended for storage and display of packaged products only. **Cold food cannot be inserted for rethermalization while hot food is being held.**

OPERATING INSTRUCTIONS *(continued)*



Running the Cycle:

1. The control will flash “PUSH StArt” after the cabinet has preheated to the set temp and the alarm will sound.

NOTE: A short beep will occur every 90 seconds as a reminder. This can be turned off in the user menu by holding the knob and the TIME buttons together for 5 seconds, then scrolling to “PSrE”, changing “y” to “n”, scrolling to “End”, and pushing the knob to set.

2. Load foods into oven and close the door.
3. Push the START button to begin the Retherm/Cook process. Display will change between the setpoint temperature and the countdown of the timer.
4. The alarm will sound after the time is done and the oven will switch back into HOLD mode. The timer will now count up, showing how long the food has been holding.

-DX OVENS

Cooking:

1. Press the COOK button.
2. Turn the control knob to the desired cooking temperature between 180°F (82°C) and 350°F (176°C).
3. Push the knob to set the temperature.
4. The control automatically switches to allow you to set HOLD temp. (Continue to step 1 below).

Holding:

(To use as holding cabinet only, skip steps 1-4 above and press HOLD button. Complete steps 1-3 below.)

1. Turn the control knob to the desired holding temperature between 135° (57°C) and 220°F (104°C).
2. Push the knob to set the temperature.
3. The control automatically switches to allow you to set cook time.

If cooking with timer, continue to step 1 below. If cooking with food probe, skip to section “Cooking with Food Probe”.

Cooking with Timer:

1. Turn the control knob to the desired hours/minutes. Oven will switch from COOK to HOLD mode when this time is done.
2. Push the knob to set the time.
3. Oven will switch to PREHEAT mode and control will display “PrEHt”.

Cooking with Food Probe:

NOTE: Make sure probe was plugged in after step 1 of Holding above. If not, press the PROBE button and continue to next step below.

1. Turn the control knob to the desired temperature. The oven will switch from COOK to HOLD mode when the probe reaches this temp.
2. Push the knob to set the temperature.
3. Oven will switch to PREHEAT mode and control will display “PrEHt”.

Running the Cycle:

1. The control will flash “PUSH StArt” after the cabinet has preheated to the set temp and the alarm will sound.

NOTE: A short beep will occur every 90 seconds as a reminder. This can be turned off in the user menu by holding the knob and the TIME buttons together for 5 seconds, then scrolling to “PSrE”, changing “y” to “n”, scrolling to “End”, and pushing the knob to set.

2. Load foods into oven, insert probe (if applicable) and close the door.
3. Push the START button to begin the Retherm/Cook process.
 - a. If cooking with timer, display will alternate between the setpoint temperature and the countdown of the timer.
 - b. If cooking with probe, display will show the probe temp.

Retherm Humidity Oven	FL-2392
Rev. 0 (5/16)	Page 6 of 15

OPERATING INSTRUCTIONS *(continued)*



-DX OVENS, *continued*

- The alarm will sound after the time is done and the oven will switch back into HOLD mode. The timer will now count up, showing how long the food has been holding.

NOTE: At any time, the CANCEL button can be pushed to return the oven back to HOLD mode at the previous set temperature. The DISPLAY button shows (cycles through) all the values when in each mode:

- “PrEHt” or “PUSH StArt”: Momentarily shows actual oven temperature.
- “COOK (timed)”: Shows home screen, set point, count down time, actual oven temperature.
- “COOK (probe)”: Shows home screen, set point, count up time, actual oven temperature.
- “HOLD”: Shows home screen, set point, count up time, actual oven temperature.

RECIPES:

The -DX control can hold up to 18 saved recipes.

To save a recipe:

- Press the RECIPE button.
- Turn the knob through the menu until you get to “Edit” and press the knob.
- Turn the knob to reach the recipe you want to edit. There are 18 blank recipes to customize and save.
- Press the knob and enter the cook, hold and time values.
- After the entering the final value, “Edt” will show again, allowing you to edit another recipe.
- Press the knob to edit more recipes or turn to “End” to exit the menu.

To use one of the recipes:

- Push the RECIPE button.
- Turn the knob to the desired recipe; “rcP01”, “rcP02”, “rcP03”, etc.
- Push the set button to select and start the preset process. Unit will begin to preheat.
- Run the cycle as described above by pressing START button after oven has preheated.

Note: The display button will cycle through all the values as before, but will include the recipe number, if using a saved recipe. Additional Menu Settings:

Additional Menu Settings:

Press and hold both the TIME button and the knob for 5 seconds to get into the menu.

Here you can set the recipes, temperature units (°C or °F), PUSH START reminder and the datalog settings (USB connection required):

”RECE” allows you to enable or disable the data record feature.

”RECF” allows you set how often (in minutes) a datapoint will be recorded.

”RECD” allows you to set how long (in days) you would like the data to be stored in memory.

OPERATING INSTRUCTIONS, continued



HOW TO USE THE AQUATEMP HUMIDTY CONTROL:

- *The units of the humidity control are approximate % relative humidity. The amount of moisture will vary for the same %RH value at different oven temperatures.
- * The LOW WATER Light comes on when water pan needs to be refilled.
- *Press the ON/OFF button to turn it on.

Setting the Humidity:

1. At any time, press the knob and the setpoint %RH will flash.
2. Turn the knob to the value you desire.
3. Press the knob to set the value.

For use with the Retherm Control:

1. On the Retherm control, when selecting the COOK temperature, the humidity setpoint will be flashing on the Aquatemp control.
2. Turn the knob on the humidity control to the desired "Cook Humidity" value.
3. On the Retherm control, when selecting the HOLD temperature setpoint, the humidity setpoint will be flashing on the Aquatemp control.
4. Turn the knob on the humidity control to the desired "Hold Humidity" value.

NOTE: These humidity values then are set and switch automatically based upon which Retherm mode it is in.

The DISPLAY BUTTON momentarily shows the approximate relative humidity in the oven. When water level is low, %RH is not correct, so no value is displayed and the water heater does not heat.

How to use the Automatic Water Fill:

There is a water fill connection under the bottom left rear of the oven. Remove the plug on the end of the connector.

1. Connect the plastic tubing provided to the connector and the other end to your water supply. Turn water supply on.
2. Press and hold both the DISPLAY button and the knob of the AquaTemp humidity control for five seconds.
3. Turn the knob until when the display shows FILL, select "Y" for yes and press the knob to set.
4. Go to END to exit the menu. Auto water fill should start.

To shut down:

1. Press and hold both the DISPLAY button and the knob of the Aquatemp humidity control.
2. Turn the knob to FILL and push to enter. Select "N" for no; go to END to exit the menu.
3. Turn off your water supply and clean out the water pan after it cools (See "Maintenance Instructions" on page 8).

NOTES: It is recommended to use treated water to prevent failure of fill valve.

If water supply pressure is high, it is recommended to regulate it to make sure the fill valve closes reliably.

Retherm Humidity Oven	FL-2392
Rev. 0 (5/16)	Page 8 of 15



MAINTENANCE INSTRUCTIONS

HOW TO CLEAN THE UNIT

MAINTENANCE: WATER PAN

Drain, wipe and fill water pan daily.
(Clear vinyl drain-hose is provided).

1. Push hose onto drain nozzle under the base.
2. Turn knob to open the drain.

To Fully Dry Out:

1. Drain until 1/8" of water is left in pan bottom.
2. Run oven at 350°F (173°C) until water is gone.
3. Wipe out pan.



Delime or descale water pan parts as required, to prevent damaging build-up. WARRANTY COVERAGE MAY BE AFFECTED WITHOUT PROPER CLEANING.

MAINTENANCE: OVEN

1. Wipe the inside of oven after daily use.
2. Leave doors slightly open to fully dry interior.



BEFORE cleaning the oven:

1. **Unplug cord from wall. Allow oven to cool.**
2. **Do NOT hose oven with water.**
3. **Do NOT get water on controls.**
4. **Do NOT use abrasives or harsh chemicals.**
5. **Do NOT use "Cres Clean" (or any citrus cleaner) on labels or plastic parts.**

Cleaning Hints:

1. Use the mildest cleaning procedure that will do the job.
2. Always rub in the direction of the polish lines to avoid scratching the surface.

3. Use only a soft cloth, sponge, fibrous brushes, plastic or stainless steel pad for cleaning and scouring.
4. Rinse thoroughly with fresh water after every cleaning operation.
5. Always wipe dry to avoid water marks.

HOW TO CLEAN THE UNIT:

	SOIL	CLEANER	METHOD
OVEN Inside and Outside (Stainless Steel)	ROUTINE CLEANING	Soap, ammonia or mild detergent* and water.	1. Sponge on with cloth 2. Rinse
	STUBBORN SPOTS, STAINS	Mild abrasive made for Stainless Steel.	1. Apply with damp sponge or cloth. 2. Rub lightly.
	BURNT ON FOODS OR GREASE	Chemical oven cleaner made for Stainless Steel.	Follow oven cleaner manufacturer's directions.
	HARD WATER SPOTS & SCALE	Vinegar	1. Swab or wipe with cloth. 2. Rinse and dry.
<i>* Mild detergents include soaps and non-abrasive cleaners</i>			

MAINTENANCE INSTRUCTIONS TROUBLE-SHOOTING GUIDE, continued

HOW TO ADJUST THE DOOR LATCH:

1. For vertical (up and down movement) adjustment:
 - a. Loosen (2) screws located in magnetic strike.
 - b. Move strike up or down for alignment to magnet on latch.
 - c. Tighten screws to secure
2. For horizontal (greater or lesser magnetic draw) adjustment:
 - a. Loosen (4) screws in door latch.
 - b. Move latch forward or backward to adjust magnetism.
 - c. Tighten screws to secure.

TROUBLE-SHOOTING GUIDE

WARNING

IF OVEN GETS TOO HOT OR WON'T SHUT OFF, DISCONNECT POWER AT BRANCH PANEL. DO NOT UNPLUG CORD!

If unit is *NOT* working, first check the following causes:

1. Cord is unplugged from wall outlet.
2. Circuit breaker/fuse to wall outlet is blown.
3. Switch is turned off.
4. Fuse on back of unit is blown.

NOTE: Vent fans will not operate until the control compartment requires ventilation to limit temperatures. Replacement of electrical components must be done by a qualified electrician.

Refer to our *Service Agency list, FL-1400* of authorized service centers. Instructions for replacing parts are included in replacement parts list.

Retherm Humidity Oven	FL-2392
Rev. 0 (5/16)	Page 10 of 15



MAINTENANCE INSTRUCTIONS TROUBLE-SHOOTING GUIDE *(continued)*

PROBLEM	POSSIBLE CAUSE	SOLUTION
Oven does not turn on	1. Power switch is bad 2. Retherm control is bad.	1. Replace 2. Replace

IF THE OVEN TURNS ON:

PROBLEM	POSSIBLE CAUSE	SOLUTION
Oven does not heat, or doesn't heat properly	1. Sensor 2. Heater contactor 3. Loose wiring at heater contactor 4. Retherm control 5. High Limit	1. Replace 2. Replace 3. Replace 4. Replace 5. Replace
Blowers do not operate	1. Air retherm switch 2. Blower 3. Retherm control	1. Replace 2. Replace 3. Replace
Heater will not shut off	1. Control defective 2. Heater contactor	1. Replace 2. Replace
Vent fans do not shut off	1. Vent fan switch defective 2. Control compartment is still hot.	1. Replace 2. Wait until it cools Check "Heater will not shut off"
Vent fans do not operate (See NOTE on previous page)	1. Vent fan switch defective 2. Vent fan defective	1. Replace 2. Replace
Control will not switch from "COOK" to "HOLD" (timed mode)	1. Oven is in "PROBE" mode (DX Ovens) 2. Retherm control defective	1. Cancel recipe and switch to "TIMED" mode 2. Replace
Control will not switch from "COOK" to "HOLD" (probe mode in DX ovens only)	1. Oven is in the "TIMED" mode 2. Probe not plugged in 3. Probe defective 4. Retherm control defective	1. Cancel recipe and switch to "PROBE" mode 2. Plug in probe 3. Replace 4. Replace
Control will not switch to "COOK" (probe mode in DX ovens only)	1. Oven in "TIMED" mode 2. Probe temperature setting lower than probe temperature 3. Probe not plugged in 4. Retherm control defective	1. Switch to "PROBE" mode 2. Set probe temperature to desired temperature 3. Plug in probe 4. Replace
No Humidity	1. Water element defective 2. AquaTemp control	1. Replace 2. Replace

ERROR CODES:

CODE DISPLAYED	CAUSE	SOLUTION
no p	No meat probe	Plug in probe
Err0	Temp probe bad	Replace
Err1	Water fill time out	Connect water supply

REPLACEMENT PARTS
Include all information on nameplate when ordering parts

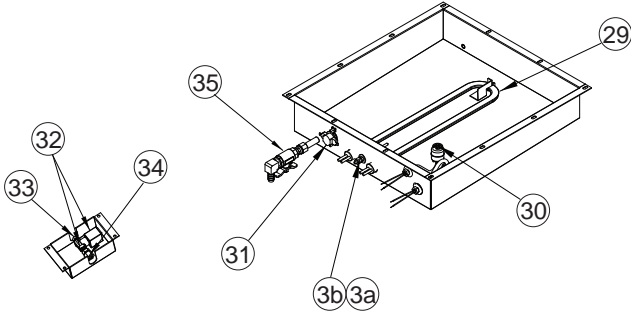
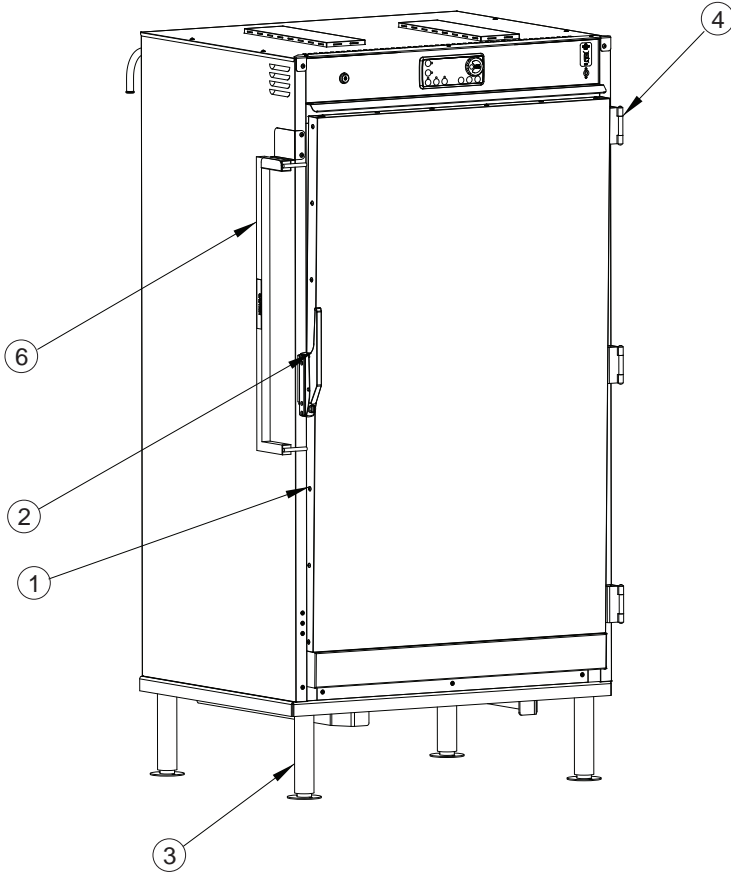

Water Pan Replacement Parts:

ITEM DESCRIPTION	PART NUMBER		
	208V	240V	480V
Water Pan Kit	0756-036-K	0756-038-K	0756-040
29. Heater	0811-278	0811-271	0811-303
30. Float Switch	0857-122-K	0857-122-K	0857-122-K
31. Hi-Limit Swtich	0848-060	0848-060	0848-060
32. Solenoid Valve	0856-018	0856-018	0856-018
33. Pipe Plug	0904-024	0904-024	0904-024
34. Adapter, Male	0904-023	0904-023	0904-023
35. Drain Valve	0898-015-K	0898-015-K	0898-015-K

Cabinet Replacement Parts:

ITEM DESCRIPTION	PART NUMBER
1. Door Assembly	1221-661
2. Latch	1006-122-01-K
Latch Strike	1006-122-02-K
3. Leg	1206-067
4. Hinge	0519-092

Model ROR201SBS1332D

Rack Replacement Parts:

ITEM DESCRIPTION	PART NUMBER
5. Casters	0569-306
Casters w/ Brake	0569-306-BSL
6. Handle, Removable	1087-105
7. Pan, Drip	1017-135

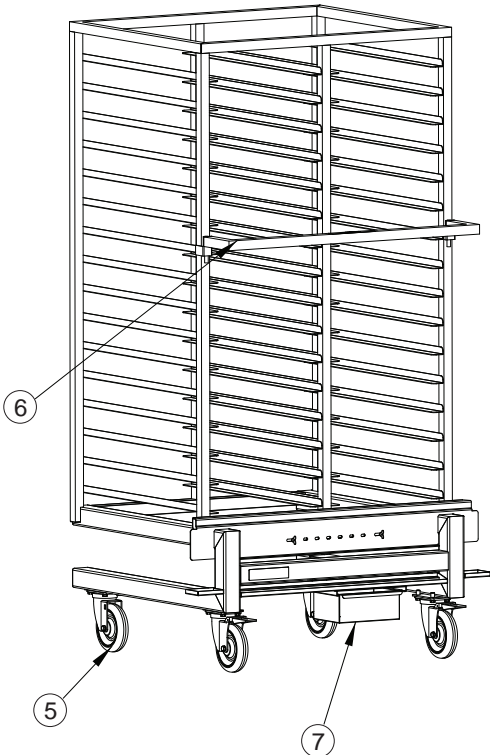

Rack Model No. ROR201SBS1332D

REPLACEMENT PARTS

Include all information on nameplate when ordering parts

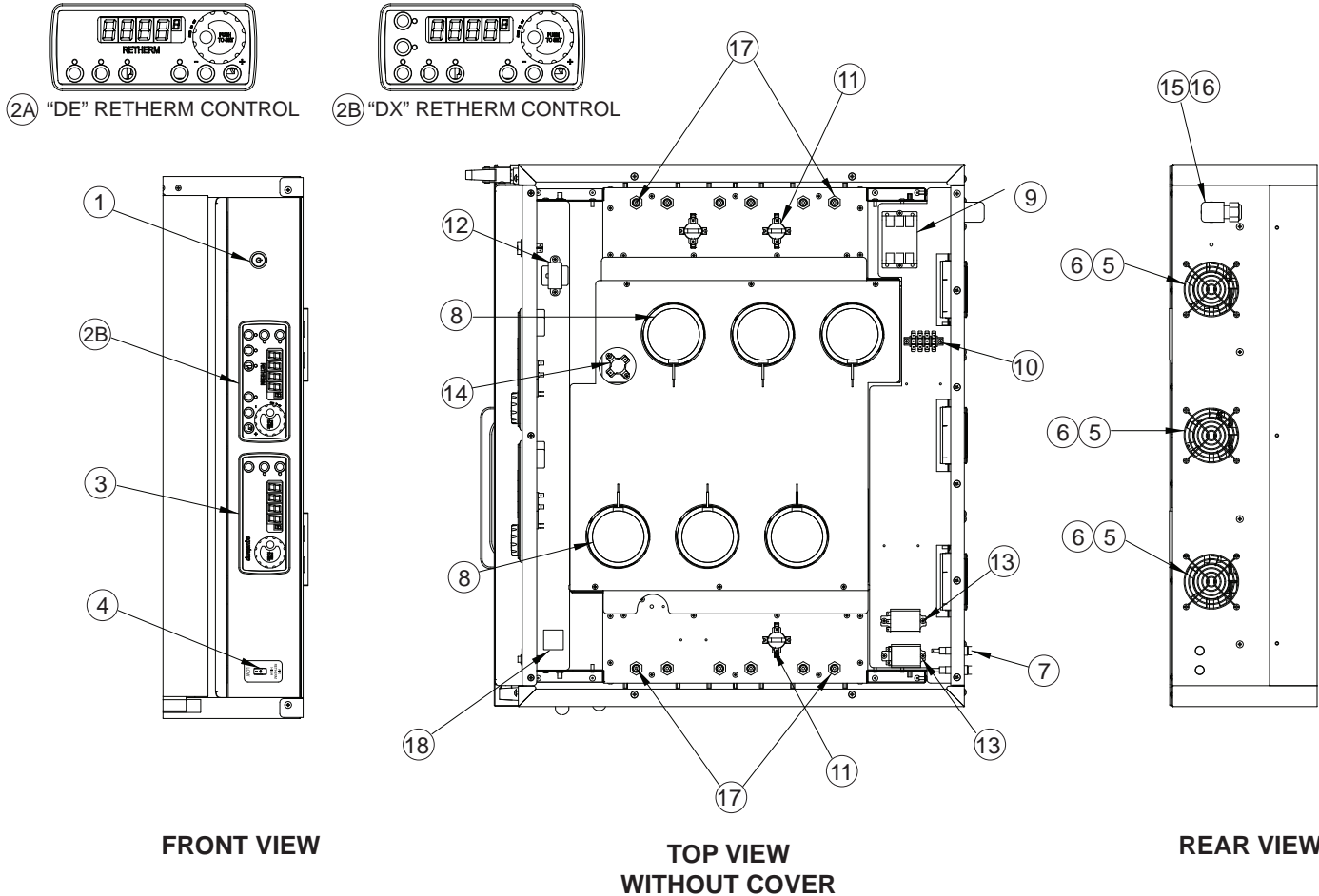

Electrical Replacement Parts:

ITEM DESCRIPTION	Part No.	ITEM DESCRIPTION	Part No.
1. Switch (On/Off)	0808-125	15. Power Cord Kits:	
2A. "DE" Retherm Control	0848-092-21-K	208/240V, 3 Ph, 60 A	0810-185
2B. "DX" Retherm Control	0848-092-04-K	208/240V, 3 Ph, 50 A	0810-178-K
Sensor	0848-091-K	208/240V, 1 Ph, 50 A	0810-161
3. Humidity Thermostat		480V, 3 Ph, 30 A	
Digital Control	0848-092-05-K	16. Strain Relief Kits:	
3a. Sensor	0848-091-K	208/240V, 3 Ph	0818-103-K
3b. Sensor bushing	0851-023	208/240V, 1 Ph	0818-061
4. Blower Switch	0808-114	480V, 3 Ph	0818-102-K
5. Vent Fan	0769-174	17. Heater Kits:	
6. Fan Guard	0769-167	3000W, 208V, 3 Ph	0811-321
7. Fuse	0807-155	3000W, 240V, 3 Ph	0811-322
Fuse Holder	0807-150	3000W, 480V, 3 Ph	0811-323
Fuse (480V)	0807-059	2000W, 208V, 3 Ph	0811-300-K
Fuse Holder (480V)	0807-048	2000W, 240V, 3 Ph	0811-301-K
8. Blower Kit	0769-186	2000W, 480V, 3 Ph	0811-302-K
9. Contactor	0857-026	1325W, 208V, 1 Ph	0811-306-K
10. Terminal Block, rear	0852-093	1325W, 240V, 1 Ph	0811-305-K
11. Hi Limit Switch	0848-077	18. Alarm Assy	0908-009-01
12. Transformer	0769-197		
Transformer (480V)	0769-198		
13. Relay	0857-102		
14. Fan Switch	0848-034		
		FOR "-DX" OVENS ONLY (not shown):	
		Connector, Probe	0848-106-02
		Food Probe 6" Long	0848-113

REPLACEMENT PARTS for OVENS RR1332DE, DX SERIES 208/240V 3 Ph

Include all information
on nameplate when
ordering parts

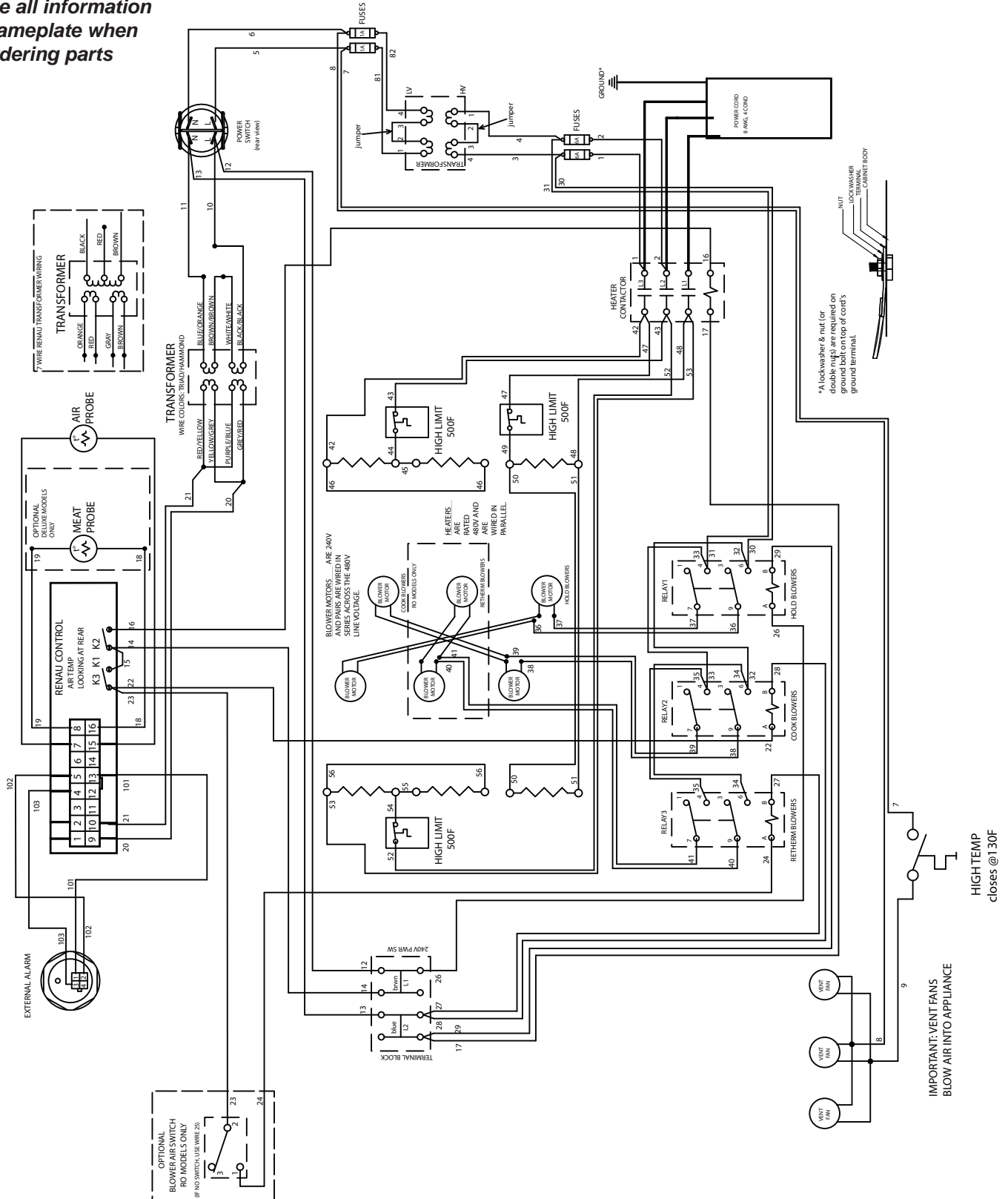

Retherm Humidity Oven	FL-2392
Rev. 0 (5/16)	Page 14 of 15

REPLACEMENT PARTS for OVENS RR1332DE, DX SERIES 480V, 3 Ph

Include all information on nameplate when ordering parts

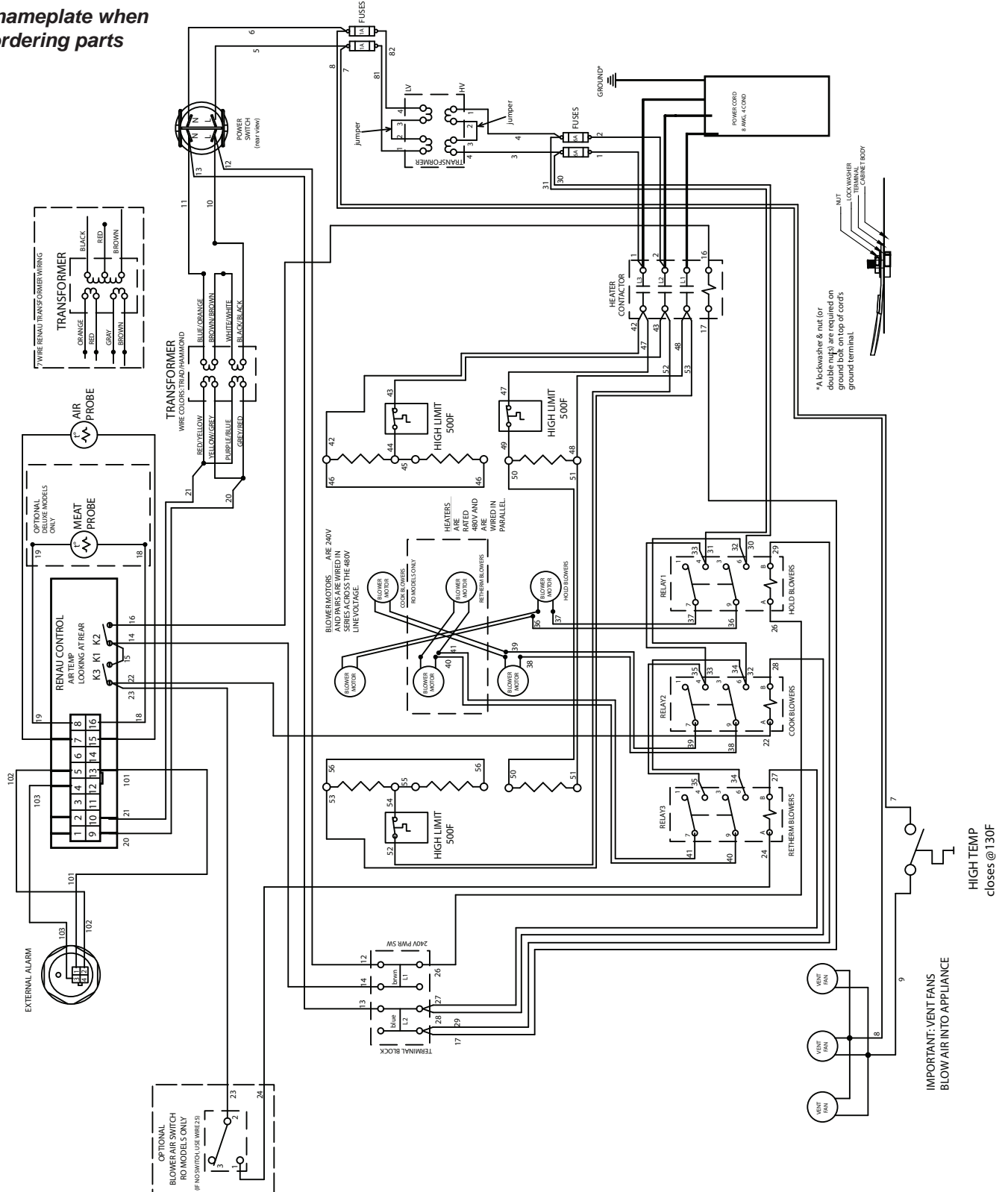

REPLACEMENT PARTS

for OVENS RR1332DE, DX SERIES 208/240V, 1 Ph

Include all information
on nameplate when
ordering parts

