

INSTALLATION, OPERATION and MAINTENANCE MANUAL for Cres Cor AquaTemp™ HUMIDITY CONVECTION OVENS



**CO151FWUA12DE
CO151FWUA12DX**



**CO151FPWUA12DE
CO151FPWUA12DX**



**CO151HWUA6DE
CO151XWUA5DE
CO151HWUA6DX
CO151XWUA5DX**

Convection Humidity Oven	FL-2373
Rev. 4 (6/15)	Page 2 of 14





TABLE OF CONTENTS

SUBJECT	PAGE
INSTALLATION INSTRUCTIONS	3
OPERATING INSTRUCTIONS	
First Time Operation	3
How to Use Control for Cooking & Holding:	
For “-DE” Series Ovens	4
For “-DX” Series Ovens	5
“Recipes” for “-DX” Series Ovens	6
How to use Aquatemp Control for Humidity	7
MAINTENANCE INSTRUCTIONS	
How to Clean the Unit	8
Trouble Shooting Guide	9,10
Oven Replacement Parts	11
Hot Unit Replacement Parts	12
Wiring Diagram For 208/240 Volt, 3 Phase	13
Wiring Diagram for 208/480 Volt, 3 Phase	14
SERVICE POLICY and AGENCY LIST	FL-1400

**REGISTERING YOUR EQUIPMENT AT www.crescor.com/service/register
COMPLETING A SURVEY EARNS AN EXTRA 90-DAY LABOR WARRANTY!**

If the equipment will not go into service immediately, please indicate that on the warranty registration. Scan QR code to register your equipment today! If you need a QR reader, visit your App Store on your Smartphone or Tablet.





WARNING

RISK OF FIRE OR ELECTRIC SHOCK
DO NOT OPEN



WARNING: TO REDUCE THE RISK OF FIRE OR ELECTRIC SHOCK,
DO NOT REMOVE COVER (OR BACK)
NO USER-SERVICEABLE PARTS INSIDE
REPAIR SHOULD BE DONE BY AUTHORIZED SERVICE PERSONNEL ONLY

INSTALLATION INSTRUCTIONS

VENTING YOUR OVEN:

- The purpose of ventilating hoods is to direct and capture smoke, grease-laden vapors, heat, odors, or fumes.
- Low temperature equipment (maximum temperature 250°F/121°C) does not produce heat, odors, fumes, grease-laden vapors or smoke and is not required to be vented.
- Most jurisdictions consider our low-temperature ovens (maximum temperature is 350°F/177°C) as low-heat appliances not requiring vent hoods.
- Installation must conform with local codes. The authority having jurisdiction of enforcement of the codes will have the responsibility for making interpretations of the rules.

UNIT SPECIFICATIONS: All units use three (3) elements (2670 watts each).

All units are rated 8000 watts. Water units have one (1) immersion element (1850 watts).

MODEL NOS.	ELECTRICAL SPECS (AC SERVICE)			ELEC. LOAD		POWER SUPPLY REQUIREMENT ALL 3 PHASE IS 3 WIRE + GROUND			
	Volts	Ph	Hz.	Amps	Volts	Amps	Ph	Volts	NEMA
CO151FWUA12DE2081	208	1	60	39	208	50	1	208	6-50P
CO151FWUA12DE2401	240	1	60	34	240	50	1	240	6-50P
CO151FWUA12DE2083	208	3	60	23	208	30	3	208	L15-30P
CO151FWUA12DE2403	240	3	60	20	240	30	3	240	L15-30P

HALF-SIZE OVENS Are rated at 4700 watts (Three [3] heaters at 1470 watts each)

CO151HWUA6DE2081	208	1	60	24	208	30	1	208	6-30P
CO151HWUA6DE2401	240	1	60	21	240	30	1	240	6-30P
CO151HWUA6DE2083	208	3	60	15	208	20	3	208	L15-20P
CO151HWUA6DE2403	240	3	60	13	240	20	3	240	L15-20P
CO151XWUA5DE2081	208	1	60	24	208	30	1	208	6-30P
CO151XWUA5DE2401	240	1	60	21	240	30	1	240	6-30P
CO151XWUA5DE2083	208	3	60	15	208	20	3	208	L15-20P
CO151XWUA5DE2403	240	3	60	13	240	20	3	240	L15-20P

All models are designed for AC Service. Model numbers may have the letters: **DX**, **P**, **L**, **M**, **Z** or **S**.

HOW TO INSTALL CABINETS:

- Remove all packing material from inside and outside of cabinet.
- Position cabinet on level floor; install the cabinet interior (pan slides) if not already installed.
- Plug power cord into proper wall receptacle.
- MANUAL FILL:** Fill water pan with three (3) gallons of HOT water (see **CAUTION**).
- AUTO FILL:** Attach water valve on back bottom of unit to water supply (see "How to use Automatic fill kit on page 7).

LOW WATER LIGHT:

MANUAL FILL: When water needs to be added to the pan, the **Low Water** Light will stay on and the humidity function will not work until the pan is refilled.

AUTO FILL: If water level is low and water supply is not connected, an error code will display after a time limit.

HOW TO CHANGE FROM °F TO °C (if needed)

- Push the switch on; the light will come on.
- Push and hold the "SET" button and the button in the lower left hand corner together for 5 seconds. You have now entered into the menu.
- Scroll over the "Unit" and change it to "C", then scroll to the "END".



Use of treated water is recommended for proper operation and to maintain warranty. It will reduce scaling.

Convection Humidity Oven	FL-2373
Rev. 4 (6/15)	Page 4 of 14

OPERATING INSTRUCTIONS



HOW TO USE ROAST-N-HOLD CONTROL:

*Push the lighted switch on the control panel; the oven will start heating and stay in HOLD mode.

*The display will read “LOTPr” (low temperature) below 140°F. (60°C.).

NOTES: Preheat for one (1) hour after start up before loading the food for best results when retherming or cooking heavy loads.

If a power outage occurs or the cabinet is shut off during a cook cycle, when it is turned on again all lights on the control will flash to indicate a disruption. Control will resume the last cook cycle used. Press any button to stop the blinking.

If your model does not have a food probe, continue to section “-DE OVENS” below.

If your model has a food probe, skip to section “-DX OVENS” on page 5.

-DE OVENS:

Cooking:

1. Press the COOK button.
2. Turn the control knob to the desired cooking temperature between 180°F (82°C) and 350°F (176°C).
3. Push the knob to set the temperature.
4. The control automatically switches to allow you to set HOLD temp. (Continue to step 1 below).

Holding:

(To use as holding cabinet only, skip steps 1-4 above and

press HOLD button. Complete steps 1-3 below.)

1. Turn the control knob to the desired holding temperature between 80°F (26°C) and 220°F (104°C).
2. Push the knob to set the temperature.
3. The control automatically switches to allow you to set cook time.

Setting the Timer:

1. Turn the control knob to the desired hours/minutes.
2. Push the knob to set the time.
3. The control automatically switches to PREHEAT mode and will display “PrEHt”

Running the Cycle:

1. The control will flash “PUSH StArt” after the cabinet has preheated to the set temp and the alarm will sound.

NOTE: A short beep will occur every 90 seconds as a reminder. This can be turned off in the user menu by holding the knob and the TIME buttons together for 5 seconds, then scrolling to “PSrE”, changing “y” to “n”, scrolling to “End”, and pushing the knob to set.

2. Load foods into oven and close the door.
3. Push the START button to begin the Cooking process. Display will change between the setpoint temperature and the countdown of the timer.
4. The alarm will sound after the time is done and the oven will switch back into HOLD mode. The timer will now count up, showing how long the food has been holding.

OPERATING INSTRUCTIONS *(continued)*



-DX OVENS

Cooking:

1. Press the COOK button.
2. Turn the control knob to the desired cooking temperature between 80°F (26°C) and 350°F (176°C).
3. Push the knob to set the temperature.
4. The control automatically switches to allow you to set HOLD temp. (Continue to step 1 below).

Holding:

(To use as holding cabinet only, skip steps 1-4 above and press HOLD button. Complete steps 1-3 below.)

1. Turn the control knob to the desired holding temperature between 80° (26°C) and 220°F (104°C).
2. Push the knob to set the temperature.
3. The control automatically switches to allow you to set cook time.

If cooking with timer, continue to step 1 below. If cooking with food probe, skip to section “Cooking with Food Probe”.

Cooking with Timer:

1. Turn the control knob to the desired hours/minutes. Oven will switch from COOK to HOLD mode when this time is done.
2. Push the knob to set the time.
3. Oven will switch to PREHEAT mode and control will display “PrEHt”.

Cooking with Food Probe:

NOTE: Make sure probe was plugged in after step 1 of Holding above. If not, press the PROBE button and continue to next step below.

1. Turn the control knob to the desired temperature. The oven will switch from COOK to HOLD mode when the probe reaches this temp.
2. Push the knob to set the temperature.

3. Oven will switch to PREHEAT mode and control will display “PrEHt”.

Running the Cycle:

1. The control will flash “PUSH StArt” after the cabinet has preheated to the set temp and the alarm will sound.

NOTE: A short beep will occur every 90 seconds as a reminder. This can be turned off in the user menu by holding the knob and the TIME buttons together for 5 seconds, then scrolling to “PSrE”, changing “y” to “n”, scrolling to “End”, and pushing the knob to set.

2. Load foods into oven, insert probe (if applicable) and close the door.
3. Push the START button to begin the Retherm/Cook process.
 - a. If cooking with timer, display will alternate between the setpoint temperature and the countdown of the timer.
 - b. If cooking with probe, display will show the probe temp.
4. The alarm will sound after the time is done and the oven will switch back into HOLD mode. The timer will now count up, showing how long the food has been holding.

NOTE: At any time, the CANCEL button can be pushed to return the oven back to HOLD mode at the previous set temperature.

The DISPLAY button shows (cycles through) all the values when in each mode:

- “PrEHt” or “PUSH StArt”: Momentarily shows actual oven temperature.
- “COOK (timed)”: Shows home screen, set point, count down time, actual oven temperature.
- “COOK (probe)”: Shows home screen, set point, count up time, actual oven temperature.
- “HOLD”: Shows home screen, set point, count up time, actual oven temperature.

Convection Humidity Oven	FL-2373
Rev. 4 (6/15)	Page 6 of 14

OPERATING INSTRUCTIONS, continued



RECIPES:

The control can hold up to 18 saved recipes.

To save a recipe:

1. Press and hold both the TIME button and the knob for 5 seconds. The screen will be flashing. This is the setup menu.
2. Turn the knob through the menu until you get to “Edit”.
3. Press the knob and turn to the recipe you want to edit. There are 18 blank recipes to customize and save.
4. Press the knob and enter the cook, hold and time values.
5. After the entering the final value, “Edit” will show again.
6. Press the knob to edit more recipes or turn to “End” to exit the menu.

To use one of the recipes:

1. Push one of the three RECIPE group buttons for the recipe number you want.
2. Turn the knob to the recipe you want and press the knob to select.
3. Press the START button to preheat.
4. After it shows “READY”, press the START button again to begin the recipe.

Note: The display button will cycle through all the values as before, but will include the recipe number, if using a saved recipe.

Quick Recipe Note:

You can set “Quick Recipes” for recipes that you use often. This way, when you press a recipe group button and press start, that recipe will start cooking without searching for the recipe number. Recipe numbers can be set up as “quick recipes” as follows:

1. Press and hold both the TIME button and the knob for 5 seconds to get into the menu.
2. Turn the knob to “RBTN” and press the knob. The word “PUSH” will flash.
3. Press one of the recipe group buttons to assign a recipe.

Note: Recipe numbers 1-6 can be set up as Group button 1.
Recipe numbers 7-12 can be set up as Group button 2.
Recipe numbers 13-18 can be set up as Group button 3.

4. Turn the knob to the recipe number you want to assign to that button and press the knob.

Repeat the process to assign recipes to the other two recipe group buttons; or, turn the knob to “END” the submenu; turn to “END” the menu.

Additional Menu Settings:

Press and hold both the TIME button and the knob for 5 seconds to get into the menu.

Here you can set the recipes, quick recipes, temperature units (°C or °F) and the datalog settings (USB connection required):

”RECE” allows you to enable or disable the data record feature.

”RECF” allows you set how often (in minutes) a datapoint will be recorded.

”RECD” allows you to set how long (in days) you would like the data to be stored in memory.

OPERATING INSTRUCTIONS, continued



HOW TO USE THE AQUATEMP HUMIDTY CONTROL:

- *The units of the humidity control are approximate % relative humidity. The amount of moisture will vary for the same %RH value at different oven temperatures.
- * The LOW WATER Light comes on when water pan needs to be refilled.
- *Press the ON/OFF button to turn it on.

Setting the Humidity:

1. At any time, press the knob and the setpoint %RH will flash.
2. Turn the knob to the value you desire.
3. Press the knob to set the value.

For use with the Roast-N-Hold Control:

1. On the Retherm control, when selecting the COOK temperature, the humidity setpoint will be flashing on the Aquatemp control.
2. Turn the knob on the humidity control to the desired "Cook Humidity" value.
3. On the Roast-N-Hold control, when selecting the HOLD temperature setpoint, the humidity setpoint will be flashing on the Aquatemp control.
4. Turn the knob on the humidity control to the desired "Hold Humidity" value.

NOTE: These humidity values then are set and switch automatically based upon which Roast-N-Hold mode it is in.

The DISPLAY BUTTON momentarily shows the approximate relative humidity in the oven. When water level is low, %RH is not correct, so no value is displayed and the water heater does not heat.

How to use the Automatic Water Fill:

There is a water fill connection under the bottom left rear of the oven. Remove the plug on the end of the connector.

1. Connect the plastic tubing provided to the connector and the other end to your water supply. Turn water supply on.
2. Press and hold both the DISPLAY button and the knob of the AquaTemp humidity control for five seconds.
3. Turn the knob until when the display shows FILL, select "Y" for yes and press the knob to set.
4. Go to END to exit the menu. Auto water fill should start.

To shut down:

1. Press and hold both the DISPLAY button and the knob of the Aquatemp humidity control.
2. Turn the knob to FILL and push to enter. Select "N" for no; go to END to exit the menu.
3. Turn off your water supply and clean out the water pan after it cools (See "Maintenance Instructions" on page 8).

NOTES: It is recommended to use treated water to prevent failure of fill valve.

If water supply pressure is high, it is recommended to regulate it to make sure the fill valve closes reliably.

Convection Humidity Oven	FL-2373
Rev. 4 (6/15)	Page 8 of 14



MAINTENANCE INSTRUCTIONS

HOW TO CLEAN THE UNIT

MAINTENANCE: WATER PAN

Drain, wipe and fill water pan daily.
(Clear vinyl drain-hose is provided).

1. Push hose onto drain nozzle under the base.
2. Turn knob to open the drain.

To Fully Dry Out:

1. Drain until 1/8" of water is left in pan bottom.
2. Run oven at 350°F (173°C) until water is gone.
3. Wipe out pan.

MAINTENANCE: CABINET

1. Wipe the inside of cabinet after daily use.
2. Leave doors slightly open to fully dry interior.



BEFORE cleaning the cabinet:

1. **Unplug cord from wall. Allow cabinet to cool.**
2. **Do NOT hose cabinet with water.**
3. **Do NOT get water on controls.**
4. **Do NOT use abrasives or harsh chemicals.**
5. **Do NOT use "Cres Clean" (or any citrus cleaner) on labels or plastic parts.**



Delime or descale water pan parts as required, to prevent damaging build-up. WARRANTY COVERAGE MAY BE AFFECTED WITHOUT PROPER CLEANING.

Cleaning Hints:

1. Use the mildest cleaning procedure that will do the job.
2. Always rub in the direction of the polish lines to avoid scratching the surface.
3. Use only a soft cloth, sponge, fibrous brushes, plastic or stainless steel pad for cleaning and scouring.
4. Rinse thoroughly with fresh water after every cleaning operation.
5. Always wipe dry to avoid water marks.

HOW TO CLEAN THE UNIT:

	SOIL	CLEANER	METHOD
CABINET Inside and Outside (Stainless Steel)	ROUTINE CLEANING	Soap, ammonia or mild detergent* and water.	1. Sponge on with cloth 2. Rinse
	STUBBORN SPOTS, STAINS	Mild abrasive made for Stainless Steel.	1. Apply with damp sponge or cloth. 2. Rub lightly.
	BURNT ON FOODS OR GREASE	Chemical oven cleaner made for Stainless Steel.	Follow oven cleaner manufacturer's directions.
	HARD WATER SPOTS & SCALE	Vinegar	1. Swab or wipe with cloth. 2. Rinse and dry.
<i>* Mild detergents include soaps and non-abrasive cleaners</i>			

MAINTENANCE INSTRUCTIONS TROUBLE-SHOOTING GUIDE, continued

HOW TO ADJUST THE DOOR LATCH:

1. For vertical (up and down movement) adjustment:
 - a. Loosen (2) screws located in magnetic strike.
 - b. Move strike up or down for alignment to magnet on latch.
 - c. Tighten screws to secure
2. For horizontal (greater or lesser magnetic draw) adjustment:
 - a. Loosen (4) screws in door latch.
 - b. Move latch forward or backward to adjust magnetism.
 - c. Tighten screws to secure.

TROUBLE-SHOOTING GUIDE

WARNING

**IF OVEN GETS TOO HOT OR WON'T SHUT OFF, DISCONNECT
POWER AT BRANCH PANEL. DO NOT UNPLUG CORD!**

If unit is *NOT* working, first check the following causes:

1. Cord is unplugged from wall outlet.
2. Circuit breaker/fuse to wall outlet is blown.
3. Switch is turned off.
4. Fuse on back of unit is blown.

NOTE: Vent fans will not operate until the control compartment requires ventilation to limit temperatures. Replacement of electrical components must be done by a qualified electrician.

Refer to our *Service Agency list, FL-1400* (found in the back of this manual), of authorized service centers. Instructions for replacing parts are included in replacement parts list.

Convection Humidity Oven	FL-2373
Rev. 4 (6/15)	Page 10 of 14



MAINTENANCE INSTRUCTIONS TROUBLE-SHOOTING GUIDE *(continued)*

PROBLEM	POSSIBLE CAUSE	SOLUTION
Oven does not turn on	1. Power switch is bad 2. Retherm control is bad.	1. Replace 2. Replace

IF THE OVEN TURNS ON:

PROBLEM	POSSIBLE CAUSE	SOLUTION
Oven does not heat, or doesn't heat properly	1. Sensor 2. Heater contactor 3. Loose wiring at heater contactor 4. Oven control 5. High Limit	1. Replace 2. Replace 3. Replace 4. Replace 5. Replace
Blowers do not operate	1. Blower 2. Oven control	1. Replace 2. Replace 3. Replace
Heater will not shut off	1. Control defective 2. Heater contactor	1. Replace 2. Replace
Vent fans do not shut off	1. Vent fan switch defective 2. Control compartment is still hot.	1. Replace 2. Wait until it cools Check "Heater will not shut off"
Vent fans do not operate	1. Vent fan switch defective 2. Vent fan defective	1. Replace 2. Replace
Control will not switch from "COOK" to "HOLD" (timed mode)	1. Oven is in "PROBE" mode (DX oven) 2. Oven control defective	1. Cancel recipe and switch to "TIMED" mode 2. Replace
Control will not switch from "COOK" to "HOLD" (probe mode in DX ovens only)	1. Oven is in the "TIMED" mode 2. Probe not plugged in 3. Probe defective 4. Oven control defective	1. Cancel recipe and switch to "PROBE" mode 2. Plug in probe 3. Replace 4. Replace
Control will not switch to "COOK" (probe mode in DX ovens only)	1. Oven in "TIMED" mode 2. Probe temperature setting lower than probe temperature 3. Probe not plugged in 4. Oven control defective	1. Switch to "PROBE" mode 2. Set probe temperature to desired temperature 3. Plug in probe 4. Replace
No Humidity	1. Water element defective 2. AquaTemp control	1. Replace 2. Replace

ERROR CODES:

CODE DISPLAYED	CAUSE	SOLUTION
no p	No meat probe	Plug in probe
Err0	Temp probe bad	Replace
Err1	Water fill time out	Connect water supply

REPLACEMENT PARTS

Include all information on nameplate when ordering parts

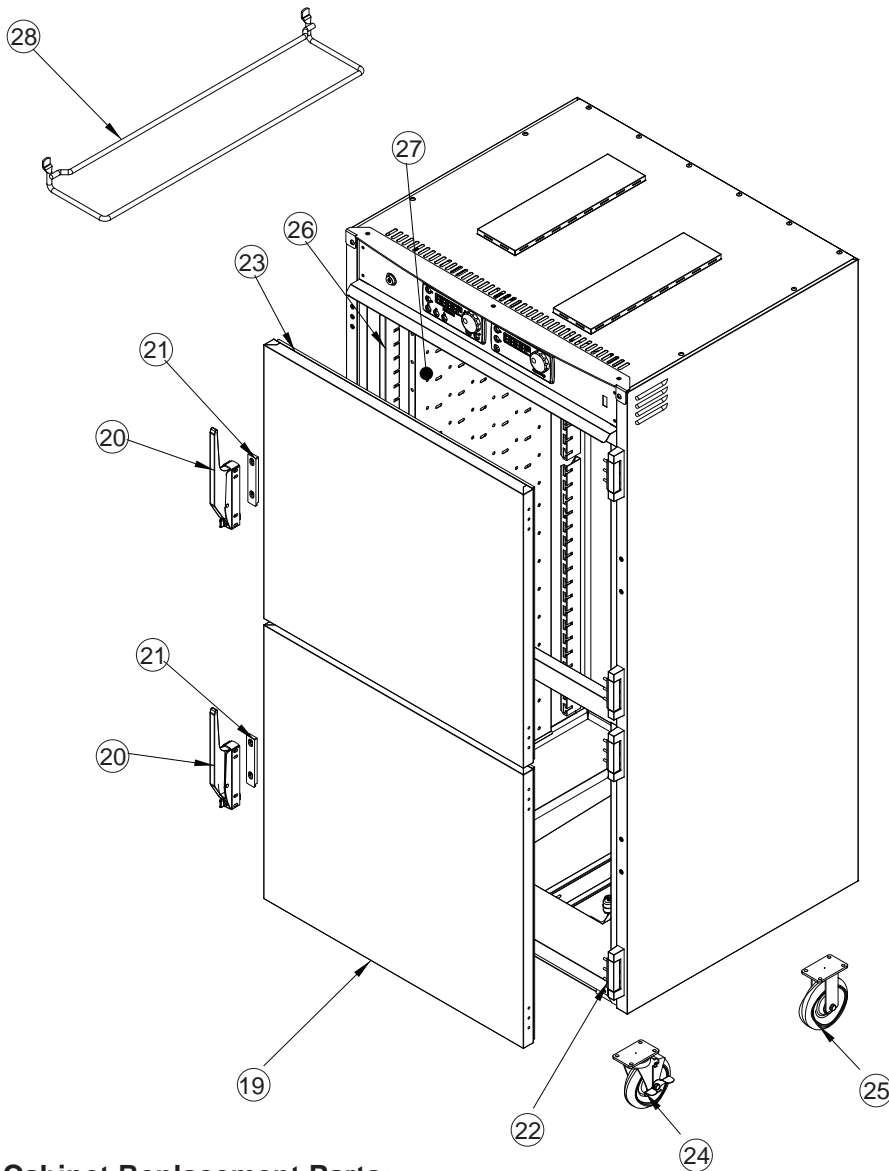

Replacement Parts:

ITEM DESCRIPTION	PART NUMBER	
	208V	240V
Water Pan Kit	0756-036-K	0756-038-K
29. Heater	0811-278	0811-271
30. Float Switch	0857-122-K	0857-122-K
31. Hi-Limit Swtich	0848-060	0848-060
32. Solenoid Valve	0856-018	0856-018
33. Pipe Plug	0904-024	0904-024
34. Adapter, Male	0904-023	0904-023
35. Drain Valve	0898-015-K	0898-015-K

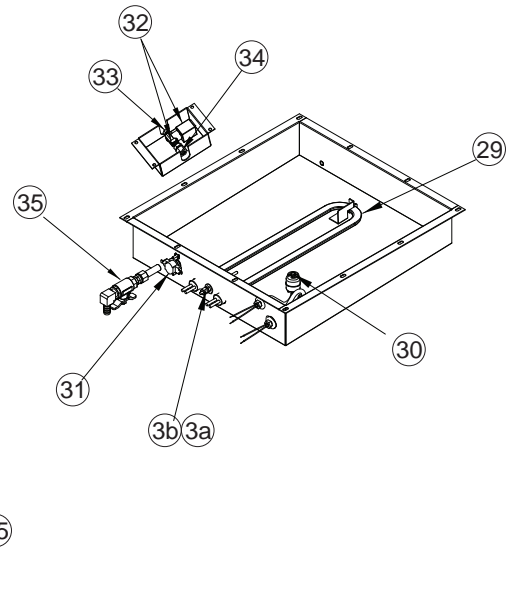

Cabinet Replacement Parts:

MODEL PREFIX CO-151						
Item No	DESCRIPTION	-FPWUA12D	-FWUA12D	-FW1332D	-HWUA6D	-XWUA5D
20	Door Latch Kit	1006-122-01-K	1006-122-01-K	1006-122-01-K	1006-122-01-K	1006-122-01-K
21	Door Strike	1006-122-02-K	1006-122-02-K	1006-122-02-K	1006-122-02-K	1006-122-02-K
22	Door Hinge	0519-109	0519-109	0519-109	0519-109	0519-109
19	Door Assembly	1221-579-K	1221-579-K	1221-585-K	1221-579-K	1221-597-K
23	Door Gasket	0861-185-K	0861-185-K	0861-274	0861-185-K	0861-250-K
28	Angles Kit (Set of 2)	0621-281-SS-K	0621-281-SS-K	0621-281-SS-K	0621-281-SS-K	0621-281-SS-K
24	Casters	0569-306-K	0569-306-K	0569-306-K	0569-306-K	0569-310
25	Casters w/Brake	0569-306-BK	0569-306-BK	0569-306-BK	0569-306-BK	0569-310-B
26	Posts	0696-250	0696-250	0696-250	0696-250	0696-252
27	Air Tunnel	0546-146-C	0546-146-C	0546-146-C	0546-161	0546-162
	Pan, Drip	1017-058	1017-058	1017-058	1017-058	1017-098

REPLACEMENT PARTS

Include all information on nameplate when ordering parts

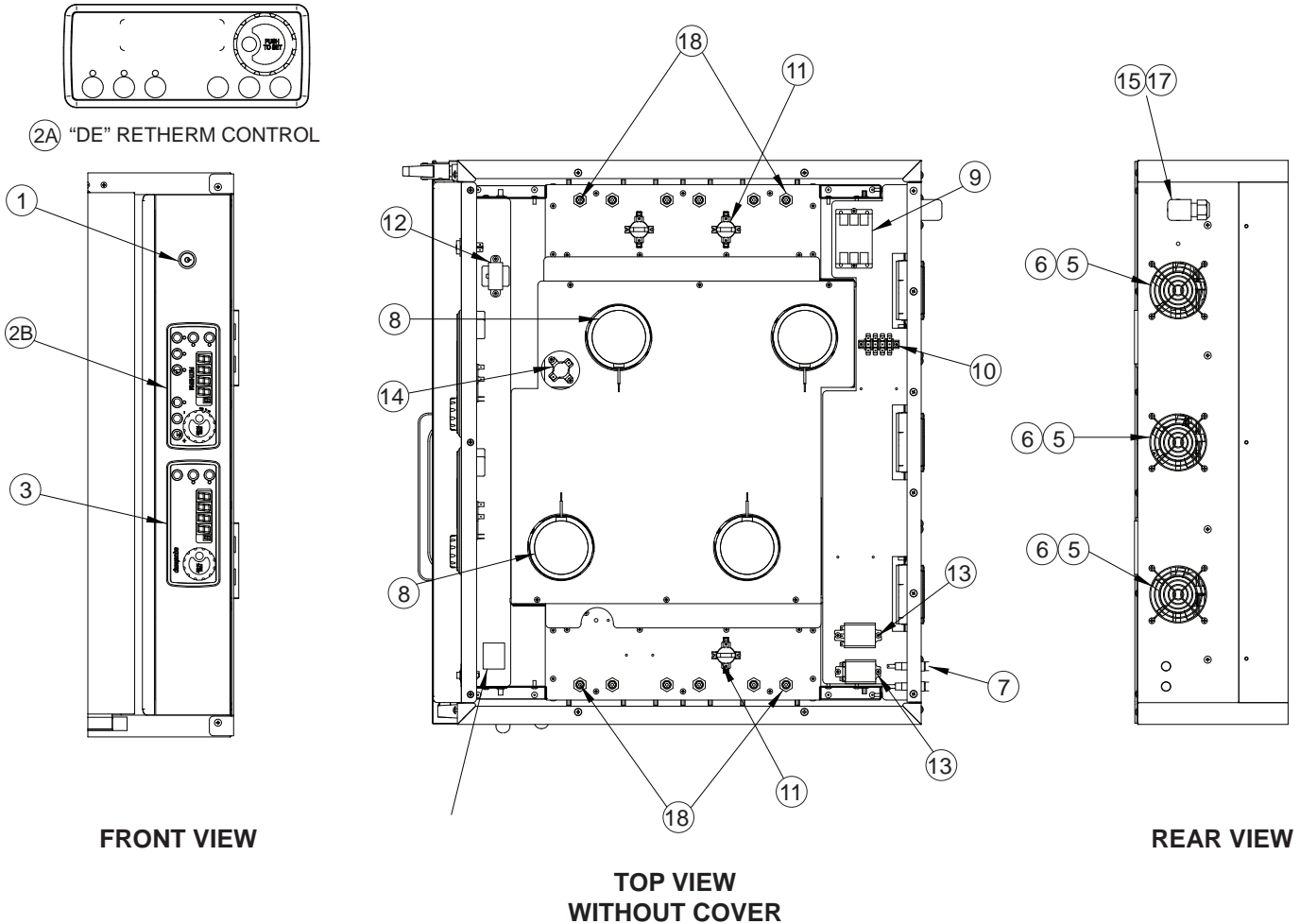

Electrical Replacement Parts:

ITEM DESCRIPTION

1. Switch (On/Off)	Part No. 0808-125
2A. "DE" Retherm Control	0848-092-23-K
2B. "DX" Retherm Control Sensor	0848-092-07-K 0848-091-K
3. Humidity Thermostat Digital Control	0848-092-05-K
3a. Sensor	0848-091-K
3b. Sensor bushing	0851-023
5. Vent Fan	0769-174
6. Fan Guard	0769-167
7. Fuse	0807-155
Fuse Holder	0807-150

ITEM DESCRIPTION

8. Blower Kit	Part No. 0769-182-SS-K
9. Contactor	0857-026
10. Terminal Block, rear	0852-093
11. Hi Limit Switch	0848-077
12. Transformer	0769-197
13. Relay	0857-102
14. Fan Switch	0848-034
16. Alarm Assy	0908-009-01
For "DX" Ovens Only:	
Connector, Probe (not shown)	0848-106-02
Food Probe 6" Long, 48" Leads	0848-113
Food Probe 6" Long, 28" Leads	0848-112

ITEM DESCRIPTION	8000W, 1PH	8000W, 3PH	4700W, 1PH	4700W, 3PH
15 Power Cord	0810-124	0810-132	0810-163	0810-164
18 Heater Kit, 208V	0811-306	0811-306	0811-311	0811-311
18 Heater Kit, 240V	0811-305	0811-305	0811-312	0811-312
17 Strain Relief	0818-061	0818-050	0818-102	0818-050

Convection Humidity Oven	FL-2373
Rev. 4 (6/15)	Page 14 of 14

WIRING DIAGRAM

OVENS CO151FW SERIES 208/240V 3 Ph

