

Convection Oven	<b>FL-2368</b>
Rev. 3 (2/15)	Page 1 of 13

## INSTALLATION, OPERATION and MAINTENANCE MANUAL for Cres Cor CONVECTION OVENS



CO151FUA12DE  
CO151FUA12DX  
CO151F1818DE  
CO151F1818DX  
CO151F1332DE  
CO151F1332DX

CO151FPUA12DE  
CO151FPUA12DX

Convection Oven	<b>FL-2368</b>
Rev. 3 (2/15)	Page 2 of 13



## TABLE OF CONTENTS

SUBJECT	PAGE
INSTALLATION INSTRUCTIONS .....	3
OPERATING INSTRUCTIONS	
First Time Operation .....	3
How to Use Control for Cooking & Holding:	
For “-DE” Series Ovens .....	4
For “-DX” Series Ovens .....	5
“Recipes” for “-DX” Series Ovens .....	6
MAINTENANCE INSTRUCTIONS	
How to Clean the Unit .....	7
Trouble Shooting Guide .....	8,9
Cabinet Replacement Parts .....	10
Hot Unit Replacement Parts .....	11
Wiring Diagram For 208/240 Volt, 1 Phase .....	12
Wiring Diagram for 208/240 Volt, 3 Phase .....	13
SERVICE POLICY and AGENCY LIST .....	FL-1400

**REGISTERING YOUR EQUIPMENT AT [www.crescor.com/service/register](http://www.crescor.com/service/register)  
COMPLETING A SURVEY EARNS AN EXTRA 90-DAY LABOR WARRANTY!**

**If the equipment will not go into service immediately, please indicate that on the warranty registration. Scan QR code to register your equipment today! If you need a QR reader, visit your App Store on your Smartphone or Tablet.**



	<b>WARNING</b>	
RISK OF FIRE OR ELECTRIC SHOCK DO NOT OPEN		
WARNING: TO REDUCE THE RISK OF FIRE OR ELECTRIC SHOCK,		
DO NOT REMOVE COVER (OR BACK)		
NO USER-SERVICEABLE PARTS INSIDE		
REPAIR SHOULD BE DONE BY AUTHORIZED SERVICE PERSONNEL ONLY		

## INSTALLATION INSTRUCTIONS

### VENTING YOUR OVEN:

1. This cabinet passes the EPA 202 test and complies with section 59 of UL710B for emission of grease-laden air.
2. According to UL, this cabinet does not need to be placed under a ventilation hood.
3. Installation must conform with local codes. The authority having jurisdiction of enforcement of the codes will have the responsibility for making interpretations of the rules.

**UNIT SPECIFICATIONS:** All units use six (6) elements (1325 watts each). All units are rated 8000 watts.

MODEL NOS.	ELECTRICAL SPECS (AC SERVICE)			ELEC. LOAD			POWER SUPPLY REQUIREMENT ALL 3 PHASE IS 3 WIRE + GROUND		
	Volts	Ph	Hz.	Amps	Volts	Ph	Amps	Volts	NEMA
CO151FUA12DE2081	208	1	60	39	208	1	50	208	6-50P
CO151FUA12DE2401	240	1	60	34	240	1	50	240	6-50P
CO151FUA12DE2083	208	3	60	23	208	3	30	208	L15-30P
CO151FUA12DE2403	240	3	60	20	240	3	30	240	L15-30P
CO151F1332DE2081	208	1	60	39	208	1	50	208	6-50P
CO151F1332DE2401	240	1	60	34	240	1	50	240	6-50P
CO151F1332DE2083	208	3	60	23	208	3	30	208	L15-30P
CO151F1332DE2403	240	3	60	20	240	3	30	240	L15-30P
CO151F1818DE2081	208	1	60	39	208	1	50	208	6-50P
CO151F1818DE2401	240	1	60	34	240	1	50	240	6-50P
CO151F1818DE2083	208	3	60	23	208	3	30	208	L15-30P
CO151F1818DE2403	240	3	60	20	240	3	30	240	L15-30P

All models are designed for AC Service. Model numbers may have the letters: **DX**, **L**, **M**, **P**, **U**, **Z** or **S**.

### HOW TO INSTALL OVENS:

1. Remove all packing material from inside and outside of oven.
2. Position oven on level floor; install the oven interior (pan slides) if not already installed.
3. Plug power cord into proper wall receptacle.

### FIRST-TIME OPERATION

**NOTE:** A new oven needs to “burn off” manufacturing oils and excessive adhesive before its first use. **Do NOT load food into oven until this has been done!**

1. Push the switch to on; the light will come on.

**NOTE:** The letters “LOtPr” (low temperature) will show on the control panel until it reaches 140°F (60°C).

### HOW TO CHANGE FROM °F TO °C (if needed)

1. Push the switch on; the light will come on.
2. Push and hold the “SET” button and the button in the lower left hand corner together for 5 seconds. You have now entered into the menu.
3. Scroll over the “Unit” and change it to “C” , then scroll to the “END” .

2. Press the “COOK” button.

3. Turn the control knob to show 350°F. Push the knob 3 times to heat the unit. Run the unit like this for one (1) hour.

4. Turn the unit off and let cool.
5. Wipe the inside clean with detergent and hot water.

Convection Oven	<b>FL-2368</b>
Rev. 3 (2/15)	Page 4 of 13

## OPERATING INSTRUCTIONS



### HOW TO USE THE ROAST-N-HOLD CONTROL:

\*Push the lighted switch on the control panel; the oven will start heating and stay in HOLD mode.

\*The display will read "LOTPr" (low temperature) below 140°F. (60°C.).

**NOTES:** Preheat for one (1) hour after start up before loading the food for best results when retherming or cooking heavy loads.

If a power outage occurs or the cabinet is shut off during a cook cycle, when it is turned on again all lights on the control will flash to indicate a disruption. Control will resume the last cook cycle used. Press any button to stop the blinking.

If your model does not have a food probe, continue to section "-DE OVENS" below.

If your model has a food probe, skip to section "-DX OVENS" on page 5.

### -DE OVENS:

#### Cooking:

1. Press the COOK button.
2. Turn the control knob to the desired cooking temperature between 180°F (82°C) and 350°F (176°C).
3. Push the knob to set the temperature.
4. The control automatically switches to allow you to set HOLD temp. (Continue to step 1 below).

#### Holding:

(To use as holding cabinet only, skip steps 1-4 above and press HOLD button. Complete steps 1-3 below.)

1. Turn the control knob to the desired holding temperature between 135°F (57°C) and 220°F (104°C).
2. Push the knob to set the temperature.
3. The control automatically switches to allow you to set cook time.

#### Setting the Timer:

1. Turn the control knob to the desired hours/minutes.
2. Push the knob to set the time.
3. The control automatically switches to PREHEAT mode and will display "PrEHt"

#### Running the Cycle:

1. The control will flash "PUSH StArt" after the cabinet has preheated to the set temp and the alarm will sound.

**NOTE: A short beep will occur every 90 seconds** as a reminder. This can be turned off in the user menu by holding the knob and the TIME buttons together for 5 seconds, then scrolling to "PSrE", changing "y" to "n", scrolling to "End", and pushing the knob to set.

2. Load foods into oven and close the door.
3. Push the START button to begin the Cooking process. Display will change between the setpoint temperature and the countdown of the timer.
4. The alarm will sound after the time is done and the oven will switch back into HOLD mode. The timer will now count up, showing how long the food has been holding.

## OPERATING INSTRUCTIONS *(continued)*



### -DX OVENS

#### Cooking:

1. Press the COOK button.
2. Turn the control knob to the desired cooking temperature between 180°F (82°C) and 350°F (176°C).
3. Push the knob to set the temperature.
4. The control automatically switches to allow you to set HOLD temp. (Continue to step 1 below).

#### Holding:

(To use as holding cabinet only, skip steps 1-4 above and press HOLD button. Complete steps 1-3 below.)

1. Turn the control knob to the desired holding temperature between 135° (57°C) and 220°F (104°C).
2. Push the knob to set the temperature.
3. The control automatically switches to allow you to set cook time.

**If cooking with timer, continue to step 1 below. If cooking with food probe, skip to section "Cooking with Food Probe".**

#### Cooking with Timer:

1. Turn the control knob to the desired hours/minutes. Oven will switch from COOK to HOLD mode when this time is done.
2. Push the knob to set the time.
3. Oven will switch to PREHEAT mode and control will display "PrEHt".

#### Cooking with Food Probe:

**NOTE:** Make sure probe was plugged in after step 1 of Holding above. If not, press the PROBE button and continue to next step below.

1. Turn the control knob to the desired temperature. The oven will switch from COOK to HOLD mode when the probe reaches this temp.
2. Push the knob to set the temperature.

3. Oven will switch to PREHEAT mode and control will display "PrEHt".

#### Running the Cycle:

1. The control will flash "PUSH StArt" after the cabinet has preheated to the set temp and the alarm will sound.

**NOTE: A short beep will occur every 90 seconds** as a reminder. This can be turned off in the user menu by holding the knob and the TIME buttons together for 5 seconds, then scrolling to "PSrE", changing "y" to "n", scrolling to "End", and pushing the knob to set.

2. Load foods into oven, insert probe (if applicable) and close the door.
3. Push the START button to begin the Retherm/Cook process.
  - a. If cooking with timer, display will alternate between the setpoint temperature and the countdown of the timer.
  - b. If cooking with probe, display will show the probe temp.
4. The alarm will sound after the time is done and the oven will switch back into HOLD mode. The timer will now count up, showing how long the food has been holding.

**NOTE:** At any time, the CANCEL button can be pushed to return the oven back to HOLD mode at the previous set temperature.

The DISPLAY button shows (cycles through) all the values when in each mode:

- "PrEHt" or "PUSH StArt": Momentarily shows actual oven temperature.
- "COOK (timed)": Shows home screen, set point, count down time, actual oven temperature.
- "COOK (probe)": Shows home screen, set point, count up time, actual oven temperature.
- "HOLD": Shows home screen, set point, count up time, actual oven temperature.

Convection Oven	<b>FL-2368</b>
Rev. 3 (2/15)	Page 6 of 13

## OPERATING INSTRUCTIONS *(continued)*



### **-DX OVENS, *continued***

#### **RECIPES:**

The -DX control can hold up to 18 saved recipes.

#### **To save a recipe:**

1. Press the RECIPE button.
2. Turn the knob through the menu until you get to "Edit" and press the knob.
3. Turn the knob to reach the recipe you want to edit. There are 18 blank recipes to customize and save.
4. Press the knob and enter the cook, hold and time values.
5. After the entering the final value, "Edt" will show again, allowing you to edit another recipe.
6. Press the knob to edit more recipes or turn to "End" to exit the menu.

#### **To use one of the recipes:**

1. Push the RECIPE button.
2. Turn the knob to the desired recipe; "rcP01", "rcP02", "rcP03", etc.
3. Push the set button to select and start the preset process. Unit will begin to preheat.
4. Run the cycle as described above by pressing START button after oven has preheated.

**Note:** The display button will cycle through all the values as before, but will include the recipe number, if using a saved recipe.

#### **Additional Menu Settings:**

Press and hold both the TIME button and the knob for 5 seconds to get into the menu.

Here you can set the recipes, temperature units (°C or °F), PUSH START reminder and the datalog settings (USB connection required):

"RECE" allows you to enable or disable the data record feature.

"RECF" allows you set how often (in minutes) a datapoint will be recorded.

"RECD" allows you to set how long (in days) you would like the data to be stored in memory.

## MAINTENANCE INSTRUCTIONS

### HOW TO CLEAN THE UNIT

#### MAINTENANCE: CABINET

1. Wipe the inside of cabinet after daily use.
2. Leave doors slightly open to fully dry interior.



#### **BEFORE** cleaning the cabinet:

1. Unplug cord from wall. Allow cabinet to cool.
2. Do NOT hose cabinet with water.
3. Do NOT get water on controls.
4. Do NOT use abrasives or harsh chemicals.
5. Do NOT use “Cres Clean” (or any citrus cleaner) on labels or plastic parts.

#### Cleaning Hints:

1. Use the mildest cleaning procedure that will do the job.
2. Always rub in the direction of the polish lines to avoid scratching the surface.
3. Use only a soft cloth, sponge, fibrous brushes, plastic or stainless steel pad for cleaning and scouring.
4. Rinse thoroughly with fresh water after every cleaning operation.
5. Always wipe dry to avoid water marks.

#### HOW TO CLEAN THE UNIT:

	SOIL	CLEANER	METHOD
<b>CABINET</b> Inside and Outside (Stainless Steel)	ROUTINE CLEANING	Soap, ammonia or mild detergent* and water.	1. Sponge on with cloth 2. Rinse
	STUBBORN SPOTS, STAINS	Mild abrasive made for Stainless Steel.	1. Apply with damp sponge or cloth. 2. Rub lightly.
	BURNT ON FOODS OR GREASE	Chemical oven cleaner made for Stainless Steel.	Follow oven cleaner manufacturer's directions.
	HARD WATER SPOTS & SCALE	Vinegar	1. Swab or wipe with cloth. 2. Rinse and dry.
<i>* Mild detergents include soaps and non-abrasive cleaners</i>			

Convection Oven	<b>FL-2368</b>
Rev. 3 (2/15)	Page 8 of 13

## MAINTENANCE INSTRUCTIONS TROUBLE-SHOOTING GUIDE, continued

### HOW TO ADJUST THE DOOR LATCH:

1. For vertical (up and down movement) adjustment:
  - a. Loosen (2) screws located in magnetic strike.
  - b. Move strike up or down for alignment to magnet on latch.
  - c. Tighten screws to secure
2. For horizontal (greater or lesser magnetic draw) adjustment:
  - a. Loosen (4) screws in door latch.
  - b. Move latch forward or backward to adjust magnetism.
  - c. Tighten screws to secure.

## TROUBLE-SHOOTING GUIDE

### **WARNING**

**IF OVEN GETS TOO HOT OR WON'T SHUT OFF, DISCONNECT POWER AT BRANCH PANEL. DO NOT UNPLUG CORD!**

**If unit is *NOT* working, first check the following causes:**

1. Cord is unplugged from wall outlet.
2. Circuit breaker/fuse to wall outlet is blown.
3. Switch is turned off.
4. Fuse on back of unit is blown.

**NOTE:** Vent fans will not operate until the control compartment requires ventilation to limit temperatures. Replacement of electrical components must be done by a qualified electrician. Refer to our *Service Agency list, FL-1400* (found in the back of this manual), of authorized service centers. Instructions for replacing parts are included in replacement parts list.

## MAINTENANCE INSTRUCTIONS TROUBLE-SHOOTING GUIDE (continued)

PROBLEM	POSSIBLE CAUSE	SOLUTION
Oven does not turn on	<ol style="list-style-type: none"> <li>1. Power switch is bad</li> <li>2. Retherm control is bad.</li> </ol>	<ol style="list-style-type: none"> <li>1. Replace</li> <li>2. Replace</li> </ol>

### IF THE OVEN TURNS ON:

PROBLEM	POSSIBLE CAUSE	SOLUTION
Oven does not heat, or doesn't heat properly	<ol style="list-style-type: none"> <li>1. Sensor</li> <li>2. Heater contactor</li> <li>3. Loose wiring at heater contactor</li> <li>4. Oven control</li> <li>5. High Limit</li> </ol>	<ol style="list-style-type: none"> <li>1. Replace</li> <li>2. Replace</li> <li>3. Replace</li> <li>4. Replace</li> <li>5. Replace</li> </ol>
Blowers do not operate	<ol style="list-style-type: none"> <li>1. Blower</li> <li>2. Oven control</li> </ol>	<ol style="list-style-type: none"> <li>1. Replace</li> <li>2. Replace</li> <li>3. Replace</li> </ol>
Heater will not shut off	<ol style="list-style-type: none"> <li>1. Control defective</li> <li>2. Heater contactor</li> </ol>	<ol style="list-style-type: none"> <li>1. Replace</li> <li>2. Replace</li> </ol>
Vent fans do not shut off	<ol style="list-style-type: none"> <li>1. Vent fan switch defective</li> <li>2. Control compartment is still hot.</li> </ol>	<ol style="list-style-type: none"> <li>1. Replace</li> <li>2. Wait until it cools Check "Heater will not shut off"</li> </ol>
Vent fans do not operate (See Note)	<ol style="list-style-type: none"> <li>1. Vent fan switch defective</li> <li>2. Vent fan defective</li> </ol>	<ol style="list-style-type: none"> <li>1. Replace</li> <li>2. Replace</li> </ol>
Control will not switch from "COOK" to "HOLD" (timed mode)	<ol style="list-style-type: none"> <li>1. Oven is in "PROBE" mode (DX oven)</li> <li>2. Oven control defective</li> </ol>	<ol style="list-style-type: none"> <li>1. Cancel recipe and switch to "TIMED" mode</li> <li>2. Replace</li> </ol>
Control will not switch from "COOK" to "HOLD" (probe mode in "DX" oven only)	<ol style="list-style-type: none"> <li>1. Oven is in the "TIMED" mode</li> <li>2. Probe not plugged in</li> <li>3. Probe defective</li> <li>4. Oven control defective</li> </ol>	<ol style="list-style-type: none"> <li>1. Cancel recipe and switch to "PROBE" mode</li> <li>2. Plug in probe</li> <li>3. Replace</li> <li>4. Replace</li> </ol>
Control will not switch to "COOK" (probe mode in "DX" oven only)	<ol style="list-style-type: none"> <li>1. Oven in "TIMED" mode</li> <li>2. Probe temperature setting lower than probe temperature</li> <li>3. Probe not plugged in</li> <li>4. Oven control defective</li> </ol>	<ol style="list-style-type: none"> <li>1. Switch to "PROBE" mode</li> <li>2. Set probe temperature to desired temperature</li> <li>3. Plug in probe</li> <li>4. Replace</li> </ol>

### ERROR CODES:

CODE DISPLAYED	CAUSE	SOLUTION
no p	No meat probe	Plug in probe
Err0	Temp probe bad	Replace

**REPLACEMENT CABINET PARTS**  
*Include all information on nameplate when ordering parts*  
*For Full Size Cabinets*

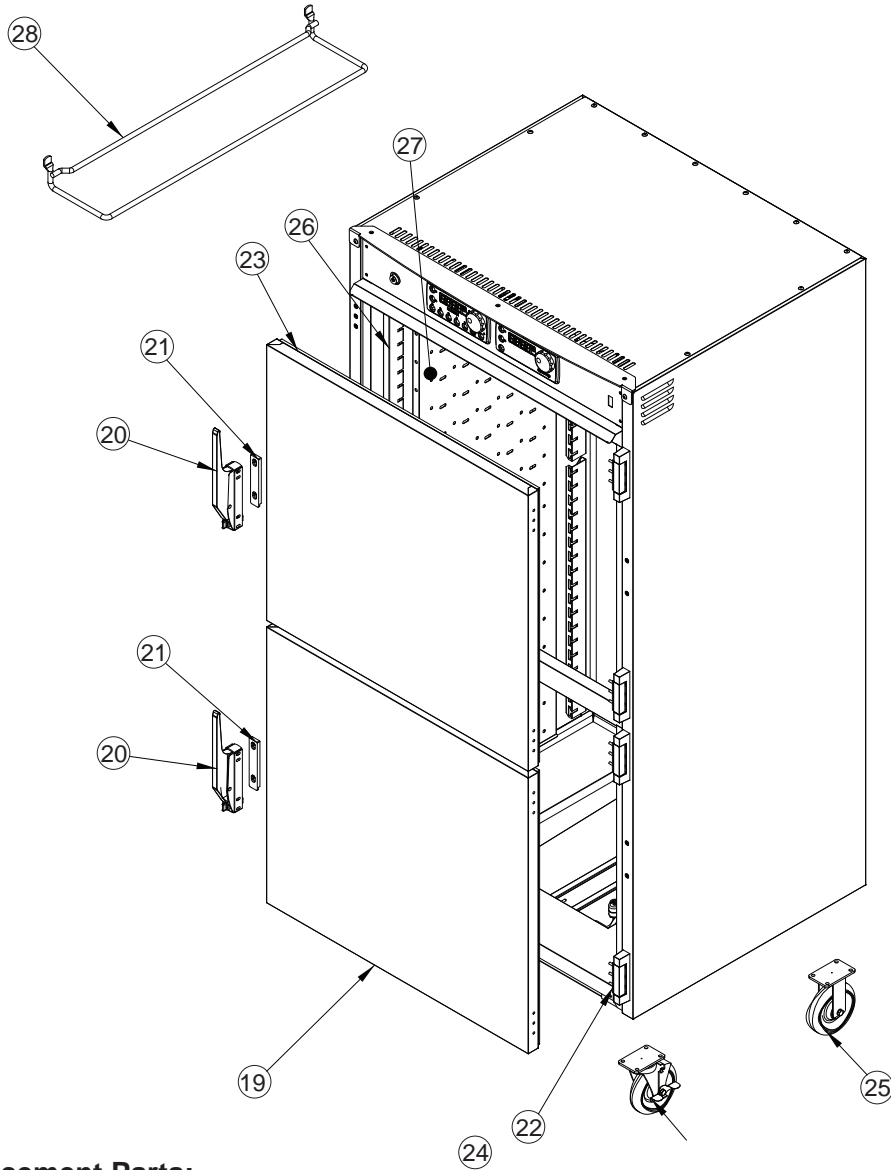

**Cabinet Replacement Parts:**

MODEL PREFIX CO-151					
Item No	DESCRIPTION	-FPUA12D	-FUA12D	-F1332D	-F1818D
20	Door Latch Kit	<a href="#">1006-122-01-K</a>	<a href="#">1006-122-01-K</a>	<a href="#">1006-122-01-K</a>	<a href="#">1006-122-01-K</a>
21	Door Strike	<a href="#">1006-122-02-K</a>	<a href="#">1006-122-02-K</a>	<a href="#">1006-122-02-K</a>	<a href="#">1006-122-02-K</a>
22	Door Hinge (Set of 2)	<a href="#">0519-109-K</a>	<a href="#">0519-109-K</a>	<a href="#">0519-109-K</a>	<a href="#">0519-109-K</a>
19	Door Assembly	<a href="#">1221-579-K</a>	<a href="#">1221-579-K</a>	<a href="#">1221-585-K</a>	<a href="#">1221-617-K</a>
23	Door Gasket	<a href="#">0861-185-K</a>	<a href="#">0861-185-K</a>	<a href="#">0861-274</a>	<a href="#">0861-197-K</a>
28	Angles Kit (Set of 2)	<a href="#">0621-281-SS-K</a>	<a href="#">0621-281-SS-K</a>	<a href="#">0621-281-SS-K</a>	-
24	Casters	<a href="#">0569-306-K</a>	<a href="#">0569-306-K</a>	<a href="#">0569-306-K</a>	<a href="#">0569-306-K</a>
25	Casters w/Brake	<a href="#">0569-306-BK</a>	<a href="#">0569-306-BK</a>	<a href="#">0569-306-BK</a>	<a href="#">0569-306-BK</a>
26	Posts or Inserts	<a href="#">0696-250</a>	<a href="#">0696-250</a>	<a href="#">0696-250</a>	<a href="#">1104-118</a>
27	Air Tunnel	<a href="#">0546-146-C</a>	<a href="#">0546-146-C</a>	<a href="#">0546-146-C</a>	<a href="#">0546-146-B</a>

**REPLACEMENT ELECTRICAL PARTS**  
*Include all information on nameplate when ordering parts*

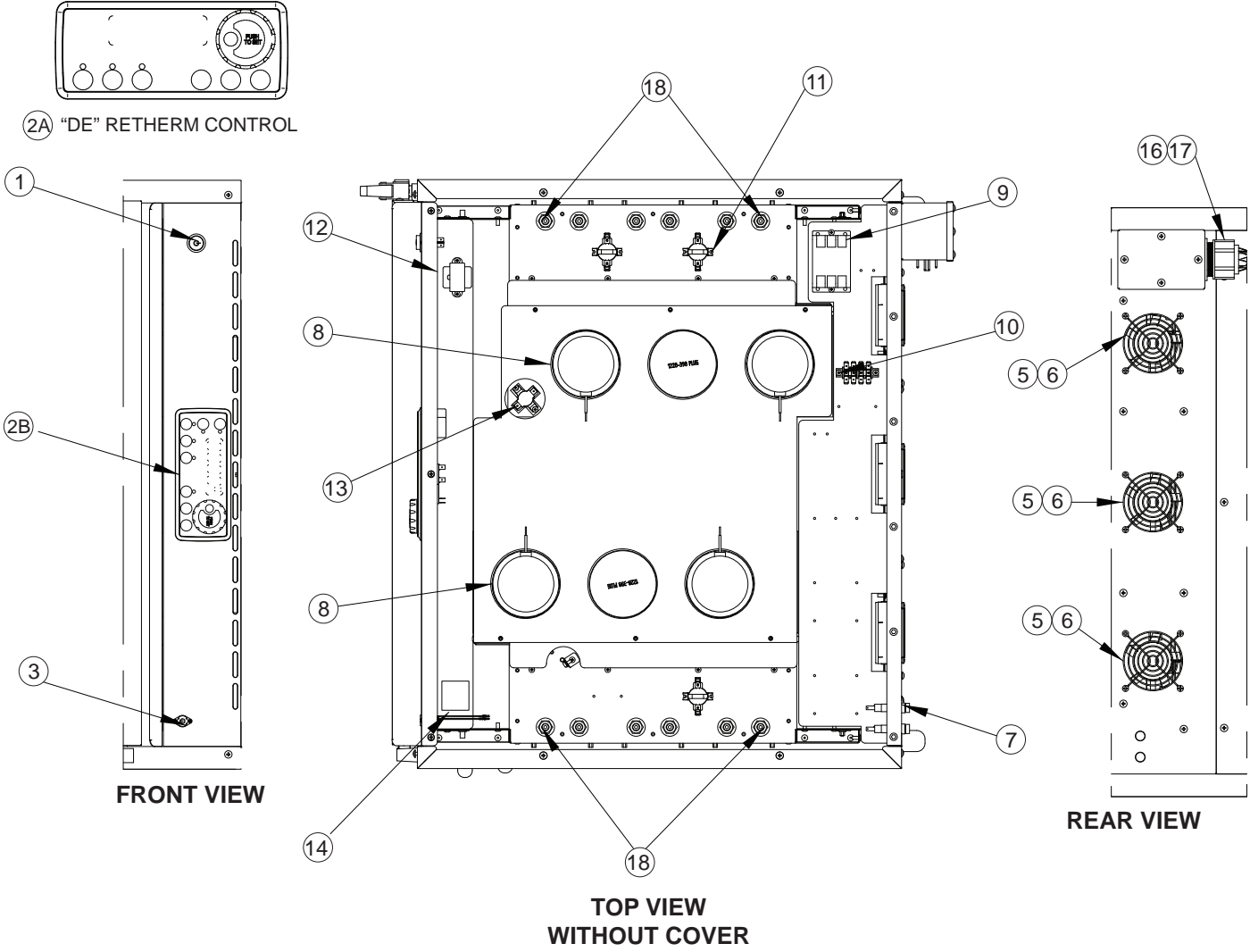

**Electrical Replacement Parts:**

**ITEM DESCRIPTION**

- 1. Switch (On/Off)
- 2A. "DE" Retherm Control
- 2B. "DX" Retherm Control

**FOR "DX" MODELS ONLY:**

- Probe Connector
- Food Probe 1.5" Long
- Food Probe 6" Long
- 5. Vent Fan
- 6. Fan Guard

**Part No.**

- 0808-125
- 0848-092-20-K
- 0848-092-06-K
- 0848-091-K
- 0848-106-02
- 0848-098
- 0848-100
- 0769-174
- 0769-167

**ITEM DESCRIPTION**

- 7. Fuse
- Fuse Holder
- 8. Blower Kit
- 9. Contactor
- 10. Terminal Block, rear
- 11. Hi Limit Switch
- 12. Transformer
- 13. Fan Switch
- 14. Alarm Assy

**Part No.**

- 0807-155
- 0807-150
- 0769-182-SS-K
- 0857-026
- 0852-093
- 0848-077
- 0769-197
- 0848-034
- 0908-009-01

ITEM DESCRIPTION	8000W, 1PH	8000W, 3PH
16 Power Cord	0810-161	0810-132
18 Heater Kit, 208V	0811-306	0811-306
18 Heater Kit, 240V	0811-305	0811-305
17 Strain Relief	0818-061	0818-050

Convection Oven	<b>FL-2368</b>
Rev. 3 (2/15)	Page 12 of 13

## WIRING DIAGRAM

### OVENS CO151F SERIES 208/240V 1 Ph

