

INSTALLATION, OPERATION and MAINTENANCE MANUAL for Cres Cor 12kW QUIK THERM™ RETHERM OVENS



RO151FUA18D
RO151FPUA18D
RO151F1332D

Retherm Oven	FL-2357
Rev. 3 (5/12)	Page 2 of 12

TABLE OF CONTENTS

SUBJECT	PAGE
INSTALLATION INSTRUCTIONS	3
OPERATING INSTRUCTIONS	
First Time Operation	3
How to Use Control for Cooking & Holding	4
How to Save and Use Recipes	5
“Quick Recipe” and Other Menu settings	5
MAINTENANCE INSTRUCTIONS	
How to Clean the Unit	6
Trouble Shooting Guide	7, 8
Cabinet Replacement Parts	9
Hot Unit Replacement Parts	10
Wiring Diagram For 208/240 Volt, 3 Phase	11
Wiring Diagram for 480 Volt, 3 Phase	12
SERVICE POLICY and AGENCY LIST	FL-1400

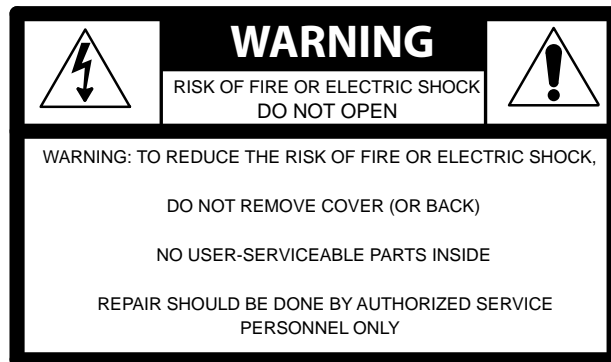

INSTALLATION INSTRUCTIONS

VENTING YOUR OVEN:

1. The purpose of ventilating hoods is to direct and capture smoke, grease-laden vapors, heat, odors, or fumes.
2. Low temperature equipment (maximum temperature 250°F/121°C) does not produce heat, odors, fumes, grease-laden vapors or smoke and is not required to be vented.
3. Most jurisdictions consider our low-temperature ovens (maximum temperature is 350°F/177°C) as low-heat appliances not requiring vent hoods.
4. Installation must conform with local codes. The authority having jurisdiction of enforcement of the codes will have the responsibility for making interpretations of the rules.

UNIT SPECIFICATIONS: All units use six (6) elements (2000 watts each). All units are rated 12000 watts.

MODEL NOS.	ELECTRICAL SPECS (AC SERVICE)			ELEC. LOAD		POWER SUPPLY REQUIREMENT ALL 3 PHASE IS 3 WIRE + GROUND		
	VOLTS	PHASES	HZ	AMPS	VOLTS	AMPS	PHASES	RECEPTACLE
RO151FUA18D2083	208	3	60	34	208	50	3	15-50R
RO151FPUA18D2083								
RO151F1332D2083								
RO151FUA18D2403	240	3	60	29	240	50	3	15-50R
RO151FPUA18D2403								
RO151F1332D2403								
RO151F1332D4803	480	3	60	15	480	30	3	L16-30R

HOW TO INSTALL CABINETS:

1. Remove all packing material from inside and outside of cabinet.
2. Position cabinet on level floor; install the cabinet interior (pan slides) if not already installed.
3. Plug power cord into proper wall receptacle.

FIRST-TIME OPERATION

NOTE: A new oven needs to “burn off” manufacturing oils and excessive adhesive before its first use.
Do NOT load food into oven until this has been done!

1. Push the switch to on; the light will come on.

HOW TO CHANGE FROM °C TO °F (if needed)

1. Push the switch on; the light will come on.
2. Push and hold the “SET” button and the button in the lower left hand corner together for 5 seconds. You are now entered into the menu.
3. Scroll over the “Unit” and change it to “C” , then scroll to the “END” .

NOTE: The letters “LOTPR” (low temperature) will show on the control panel until it reaches 140°F (60°C).

2. Press the “COOK” button.
3. Push down and turn the control knob to show 200°F. Push the knob again to set the temperature. Run the unit for one (1) hour.
4. Turn the unit off and let cool.
5. Wipe the inside clean with detergent and hot water.

Retherm Oven	FL-2357
Rev. 3 (5/12)	Page 4 of 12

OPERATING INSTRUCTIONS



AIR RETHERM SWITCH

This switch **MUST** be pushed to “HIGH” (ON) for Retherming food.

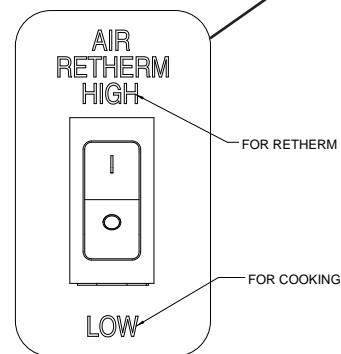

HOW TO USE THE RETHERM CONTROL:

*Push the lighted switch on the control panel; the light will come on and the cabinet will start heating.

*The display will read “LOTPR” (low temperature) below 140°F. (60°C.).

NOTE: Wait one (1) hour after start up before loading the food for best results.

The display will read “PREHT” until the cabinet reaches the set temperature.

Cooking:

1. Press the COOK button.
2. Turn the control knob to the desired cooking temperature between 200°F (93°C) and 350°F (176°C).
3. Push the knob to set the temperature.
4. The control automatically goes to the HOLD mode. (Continue to step 1 below).

Holding:

(Press the HOLD button only if you are just holding food),

1. Turn the control knob to the desired holding temperature between 140°F (60°C) and 220°F (104°C).
2. Push the knob to set the temperature.
3. The control automatically goes to the TIME mode.

Setting the time or Food Probe:

1. If **NOT** using the Food Probe:
 - a) Turn the control knob to the desired hours/minutes.
 - b) Push the knob to set the time.
2. Using the Food Probe:

Plug in the food probe **BEFORE** you enter the **TIME** mode. Otherwise, you have to press the **PROBE** button to set the probe temperature.

 - a) Turn the knob to the desired temperature.
 - b) The timer will stop when the probe reaches the set temperature.
3. Press the **START** button. The display will show “READY” when preheated.
4. Press the **START** again to use this recipe (see Recipes”).

Note: Press the knob for 4 seconds to cancel the recipe.

The **DISPLAY** button shows (cycles through) all the values when in each mode:

- “PREHEAT” OR “READY”: momentarily shows the actual cabinet temperature.
- “COOK” (Timed): shows Home screen, set point, count down time, actual cabinet temperature.
- “COOK” (Probe): shows Home screen, set point, count up time, actual cabinet temperature.
- “HOLD”: shows Home screen, set point, count up time, actual cabinet temperature.

OPERATING INSTRUCTIONS (continued)



RECIPES:

The control can hold up to 18 saved recipes.

To save a recipe:

1. Press and hold both the TIME button and the knob for 5 seconds. The screen will be flashing. This is the setup menu.
2. Turn the knob through the menu until you get to "Edit".
3. Press the knob and turn to the recipe you want to edit. There are 18 blank recipes to customize and save.
4. Press the knob and enter the cook, hold and time values.
5. After the entering the final value, "Edit" will show again.
6. Press the knob to edit more recipes or turn to "End" to exit the menu.

To use one of the recipes:

1. Push one of the three RECIPE group buttons for the recipe number you want.
2. Turn the knob to the recipe you want and press the knob to select.
3. Press the START button to preheat.
4. After it shows "READY", press the START button again to begin the recipe.

Note: The display button will cycle through all the values as before, but will include the recipe number, if using a saved recipe.

Quick Recipe Note:

You can set "Quick Recipes" for recipes that you use often. This way, when you press a recipe group button and press start, that recipe will start cooking without searching for the recipe number. Recipe numbers can be set up as "quick recipes" as follows:

1. Press and hold both the TIME button and the knob for 5 seconds to get into the menu.
2. Turn the knob to "RBTN" and press the knob. The word "PUSH" will flash.
3. Press one of the recipe group buttons to assign a recipe.

Note: Recipe numbers 1-6 can be set up as Group button 1.

Recipe numbers 7-12 can be set up as Group button 2.

Recipe numbers 13-18 can be set up as Group button 3.

4. Turn the knob to the recipe number you want to assign to that button and press the knob.
Repeat the process to assign recipes to the other two recipe group buttons; or,
turn the knob to "END" the submenu; turn to "END" the menu.

Additional Menu Settings:

Press and hold both the TIME button and the knob for 5 seconds to get into the menu.

Here you can set the recipes, quick recipes, temperature units (°C or °F) and the datalog settings (USB connection required):

"RECE" allows you to enable or disable the data record feature.

"RECF" allows you set how often (in minutes) a datapoint will be recorded.

"RECD" allows you to set how long (in days) you would like the data to be stored in memory.

MAINTENANCE INSTRUCTIONS HOW TO CLEAN THE UNIT

WARNING

BEFORE cleaning the cabinet:

1. Unplug cord from wall. Allow cabinet to cool.
2. Do NOT hose cabinet with water.
3. Do NOT get water on controls.
4. Do NOT use abrasives or harsh chemicals.
5. Do NOT use “Cres Clean” (or any citrus cleaner) on labels or plastic parts.

Cleaning Hints:

- | | |
|--|--|
| <ol style="list-style-type: none"> 1. Use the mildest cleaning procedure that will do the job. 2. Always rub in the direction of the polish lines to avoid scratching the surface. | <ol style="list-style-type: none"> 3. Use only a soft cloth, sponge, fibrous brushes, plastic or stainless steel pad for cleaning and scouring. 4. Rinse thoroughly with fresh water after every cleaning operation. 5. Always wipe dry to avoid water marks. |
|--|--|

HOW TO CLEAN THE UNIT:

	SOIL	CLEANER	METHOD
CABINET Inside and Outside (Stainless Steel)	ROUTINE CLEANING	Soap, ammonia or mild detergent* and water.	1. Sponge on with cloth 2. Rinse
	STUBBORN SPOTS, STAINS	Mild abrasive made for Stainless Steel.	1. Apply with damp sponge or cloth. 2. Rub lightly.
	BURNT ON FOODS OR GREASE	Chemical oven cleaner made for Stainless Steel.	Follow oven cleaner manufacturer's directions.
	HARD WATER SPOTS & SCALE	Vinegar	1. Swab or wipe with cloth. 2. Rinse and dry.
<i>* Mild detergents include soaps and non-abrasive cleaners</i>			

Retherm Oven	FL-2357
Rev. 3 (5/12)	Page 7 of 12



MAINTENANCE INSTRUCTIONS TROUBLE-SHOOTING GUIDE, continued

HOW TO ADJUST THE DOOR LATCH:

1. For vertical (up and down movement) adjustment:
 - a. Loosen (2) screws located in magnetic strike.
 - b. Move strike up or down for alignment to magnet on latch.
 - c. Tighten screws to secure
2. For horizontal (greater or lesser magnetic draw) adjustment:
 - a. Loosen (4) screws in door latch.
 - b. Move latch forward or backward to adjust magnetism.
 - c. Tighten screws to secure.

TROUBLE-SHOOTING GUIDE

WARNING

IF OVEN GETS TOO HOT OR WON'T SHUT OFF, DISCONNECT POWER AT BRANCH PANEL. DO NOT UNPLUG CORD!

If unit is *NOT* working, first check the following causes:

- | | |
|--|-----------------------------------|
| 1. Cord is unplugged from wall outlet. | 3. Switch is turned off. |
| 2. Circuit breaker/fuse to wall outlet is blown. | 4. Fuse on back of unit is blown. |

PROBLEM	POSSIBLE CAUSE	SOLUTION
Oven does not turn on	1. Power switch is bad 2. Retherm control is bad.	1. Replace 2. Replace

MAINTENANCE INSTRUCTIONS TROUBLE-SHOOTING GUIDE *(continued)*

IF THE OVEN TURNS ON:

PROBLEM	POSSIBLE CAUSE	SOLUTION
Oven does not heat, or doesn't heat properly	<ol style="list-style-type: none"> Sensor Heater contactor Loose wiring at heater contactor Retherm control High Limit 	<ol style="list-style-type: none"> Replace Replace Replace Replace Replace
Blowers do not operate	<ol style="list-style-type: none"> Air retherm switch Blower Retherm control 	<ol style="list-style-type: none"> Replace Replace Replace
Heater will not shut off	<ol style="list-style-type: none"> Control defective Heater contactor 	<ol style="list-style-type: none"> Replace Replace
Vent fans do not shut off	<ol style="list-style-type: none"> Vent fan switch defective Control compartment is still hot. 	<ol style="list-style-type: none"> Replace Wait until it cools Check "Heater will not shut off"
Vent fans do not operate (See Note)	<ol style="list-style-type: none"> Vent fan switch defective Vent fan defective 	<ol style="list-style-type: none"> Replace Replace
Control will not switch from "COOK" to "HOLD" (timed mode)	<ol style="list-style-type: none"> Oven is in "PROBE" mode. Retherm control defective 	<ol style="list-style-type: none"> Cancel recipe and switch to "TIMED" mode Replace
Control will not switch from "COOK" to "HOLD" (probe mode)	<ol style="list-style-type: none"> Oven is in the "TIMED" mode Probe not plugged in Probe defective Retherm control defective 	<ol style="list-style-type: none"> Cancel recipe and switch to "PROBE" mode Plug in probe Replace Replace
Control will not switch to "COOK" (probe mode)	<ol style="list-style-type: none"> Oven in "TIMED" mode Probe temperature setting lower than probe temperature Probe not plugged in Retherm control defective 	<ol style="list-style-type: none"> Switch to "PROBE" mode Set probe temperature to desired temperature Plug in probe Replace

ERROR CODES:

CODE DISPLAYED	CAUSE	SOLUTION
no p	No meat probe	Plug in probe
Err0	Temp probe bad	Replace

NOTE: Vent fans will not operate until the control compartment requires ventilation to limit temperatures. Replacement of electrical components must be done by a qualified electrician.

Refer to our *Service Agency list, FL-1400* (found in the back of this manual), of authorized service centers. Instructions for replacing parts are included in replacement parts list.

Retherm Oven	FL-2357
Rev. 3 (5/12)	Page 9 of 12

REPLACEMENT PARTS
Include all information on nameplate when ordering parts

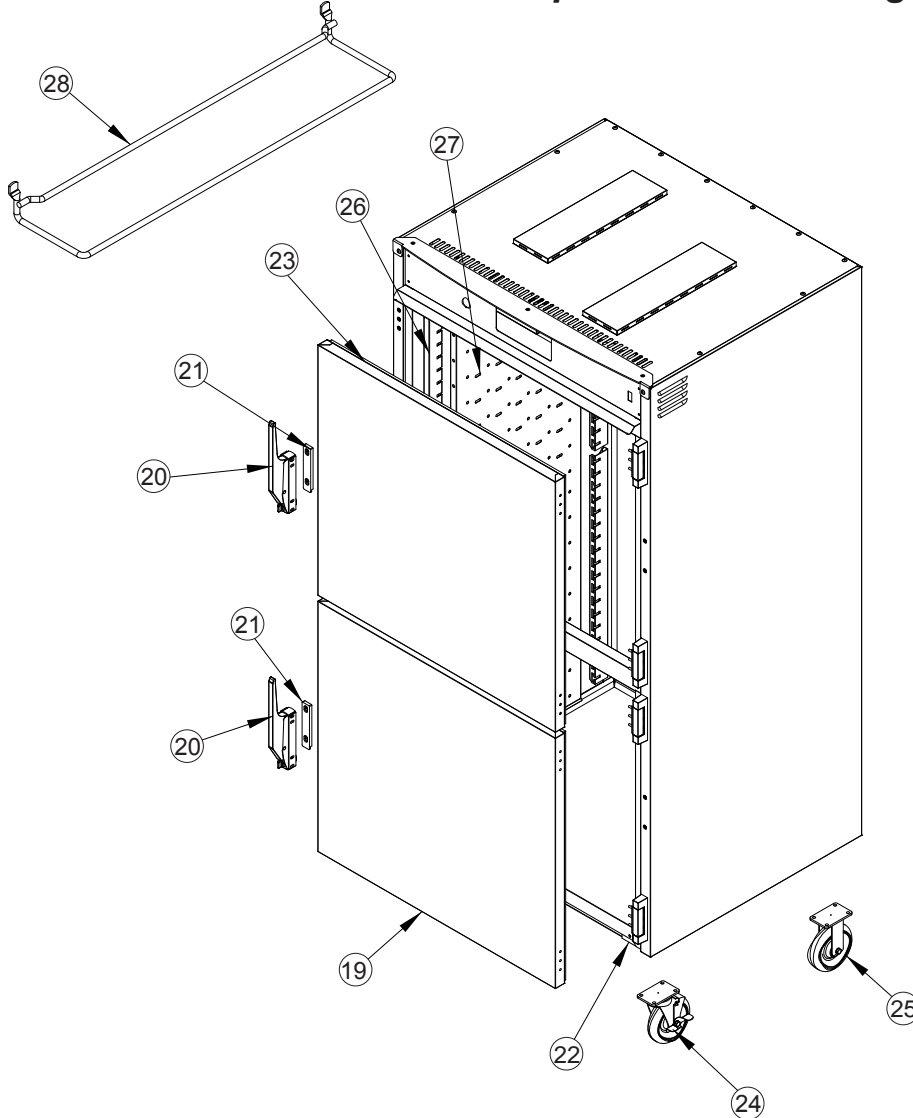

Replacement Parts:

ITEM DESCRIPTION	PART NUMBER
19. Door Assembly (1332D)	1221-579-K
Door Assembly (UA18D)	1221-580-K
20. Door Latch Kit	1006-122-01-K
21. Door Strike Kit	1006-122-02-K
22. Door Hinge Kit	0519-109-K
23. Door Gasket (1332D)	0861-185-K
Door Gasket (UA18D)	0861-235-K
24. Casters	0569-306-R
25. Casters w/brake	0569-306-B
26. Posts	0696-250
27. Air Tunnel	0546-146-C
28. Wire Angles (2 per kit)	0621-281-SS-K
Drip Pan (clear)	1017-058

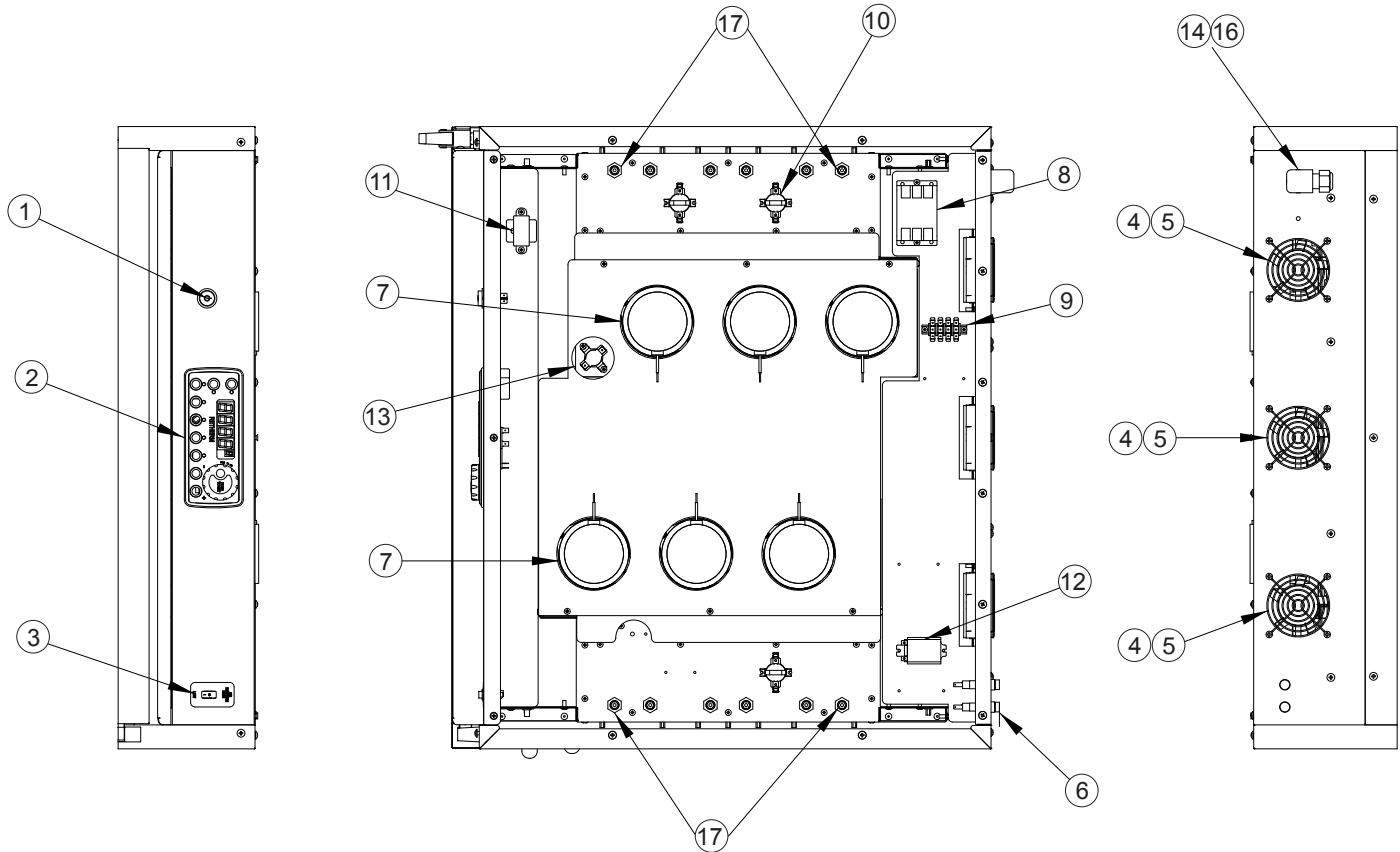

FRONT VIEW

**TOP VIEW
WITHOUT COVER**

REAR VIEW

Electrical Replacement Parts:

ITEM DESCRIPTION	Part No.
1. Switch (On/Off)	0808-125
2. Retherm Thermostat Digital Control Sensor	0848-092-03 0848-091
3. Blower Switch	0808-114
4. Vent Fan	0769-174
5. Fan Guard	0769-167
6. Fuse	0807-155
Fuse Holder	0807-150
Fuse (480V)	0807-058
Fuse Holder (480V)	0807-048
7. Blower Kit	0769-186-K
8. Contactor	0857-026
9. Terminal Block, rear	0852-093

ITEM DESCRIPTION	Part No.
10. Hi Limit Switch	0848-077
11. Transformer	0769-197
12. Relay	0857-102
13. Fan Switch	0848-034
14. Power Cord Kit	0810-178-K
16. Strain Relief Kit	0818-103-K
17. Heater Kit (208V)	0811-0300-K
Heater Kit (240V)	0811-0301-K
Heater Kit (480V)	0811-0302-K
Connector, Probe (not shown)	0848-094
Food Probe 1.5" Long	0848-098
Food Probe 6" Long	0848-100

Retherm Oven	FL-2357
Rev. 3 (5/12)	Page 11 of 12



5925 Heisley Road • Mentor, OH 44060-1833

REPLACEMENT PARTS

for NON-PASS THRU OVENS RO151F SERIES 208/240V 3 Ph

Include all information
on nameplate when
ordering parts

