

OPERATING and MAINTENANCE INSTRUCTIONS

Models: H137PWSUA...C & H138PWS1834C

Pass-Through Humidity Series Hot Cabinets

Model No.	Volts	Watts	Amps	Hertz	Phase	NEMA
H137PWSUA12C H137PWSUA9C H137PWSUA6C H138PWS1834C	120	2000	16.7	60	1	5-20P
H137PWSUA12C208 H137PWSUA9C208 H137PWSUA6C208 H138PWS1834C208	208	2000	10.0	60	1	6-15P
H137PWSUA12C240 H137PWSUA9C240 H137PWSUA6C240 H138PWS1834C240	240	2000	8.6	60	1	6-15P

NOTE: The above model numbers are basic models.
They may be followed by letters: L, M, 2M, D, or ending with S.

HOW TO INSTALL UNIT:

1. Place cabinet on level floor.
2. Plug cord end into proper wall outlet.
3. Fill water pan with 4 gallons (15 liters) of water.

 **CAUTION** Use of treated or soft water may be required for proper operation and to maintain warranty.

4. Place the cabinet in a well-ventilated area.
5. Push the switch to “On”, turn the “Air” thermostat to No. 9 and run the unit for one hour.

NOTE: DO NOT PUT FOOD IN CABINET!
This step is to burn off manufacturing oils and excess adhesive.

6. Let the cabinet cool and wipe inside clean with detergent and hot water before first use.

HOW TO PROOF:

1. Fill water pan with **HOT** water.
2. Turn “POWER” switch to “ON”.
3. Turn “AIR” thermostat to “PROOF” (No. 1).
4. Turn “HUMIDITY” thermostat to No. 3½.
5. Preheat for ½ hour (30 minutes).
6. Put fresh or *fully thawed* dough into cabinet.

NOTE: Do **NOT** put in frozen dough.

NOTE: The optional digital thermometer display flashes when temperature in center of cabinet is below 140°F/60°C or above 250°F/121°C. Call the factory if you need different settings.

 **WARNING** Air is **VERY HOT** when door is opened.

Pass-Thru Humidity Hot Cabinet	FL-2255
Rev. 13 (6/08)	Page 2 of 6

OPERATING and MAINTENANCE INSTRUCTIONS

Models: H137PWSUA...C & H138PWS1834C

Pass-Through Humidity Series Hot Cabinets

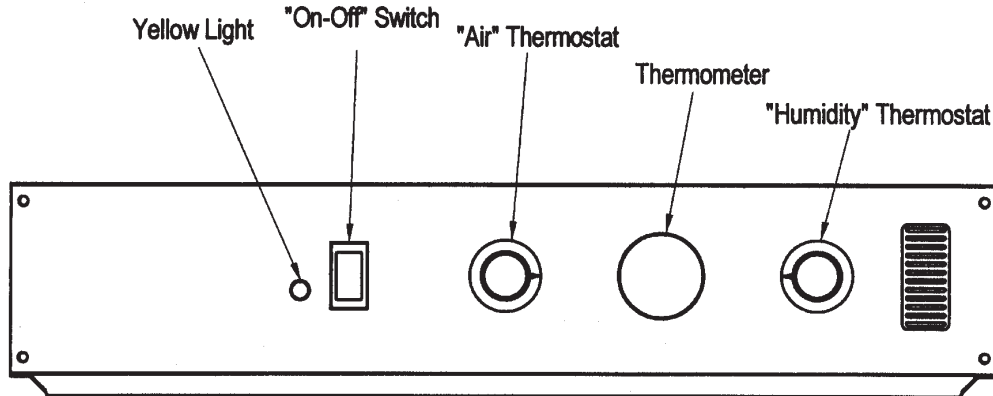

HOW TO HOLD:

1. No water is needed in pan.
2. Push power switch to "ON."
3. Yellow light will come on.
4. Turn "AIR" thermostat to No. 9.
5. Preheat cabinet for 45 minutes.
6. Turn "AIR" thermostat to desired temperature.
(See thermostat settings below.)
7. Put product into cabinet.

HOW TO HOLD WITH HUMIDITY:

1. Fill water pan with HOT water.
2. Push "POWER" switch to "ON."
3. Turn the "AIR" Thermostat to No. 9.
4. Turn the "HUMIDITY" thermostat to No. 9.
5. Preheat for 45 minutes.
6. Turn "AIR" thermostat to desired temperature.
(See thermostat settings below.)
7. Put product into cabinet.

NOTES: 180°F/82°C is approximately No. 8. Proper food holding temperature is 140°F/60°C or higher.

⚠ WARNING Air is VERY HOT when door is opened.

SOME TYPICAL THERMOSTAT SETTINGS:

Thermostat Setting		Result		Thermostat Setting		Result	
Air	Humidity	Cab. Temp.	Humidity	Air	Humidity	Cab. Temp	Humidity
150° F	Off	150° F	N/A	Low Hold	Med	160°F	50%
Med Hold	Off	175° F	N/A	Low Hold	High	160°F	95%
High Hold	Off	205° F	N/A	Med Hold	Low	170°F	15%
Maximum	Off	220° F	N/A	Med Hold	Med	170°F	35%
				Med Hold	High	170°F	85%
Proof	3½	100°F	98%	Med Hold	Max	170°F	90%
Low	Low	115° F	98%	High Hold	Low	205°F	7%
Low	Med	150° F	95%	High Hold	Med	205°F	15%
Low	High	150° F	95%	High Hold	High	205°F	40%
Low Hold	Low	160° F	30%	Maximum	Maximum	220°F	30%

Note: These settings are based on laboratory conditions and may differ from conditions at point of use. Experiment with the settings to determine what is best for your application.

OPERATING and MAINTENANCE INSTRUCTIONS

Models: H137PWSUA...C & H138PWS1834C

Pass-Through Humidity Series Hot Cabinets

MAINTENANCE: WATER PAN

Drain, wipe and fill water pan daily. (Clear vinyl drain hose is provided.)

1. Push hose onto drain nozzle under the base.
2. Turn knob to open the drain.

MAINTENANCE: CABINET

1. Wipe the inside of cabinet after daily use.
2. Leave doors slightly open to fully dry interior.



Delime or descale water pan parts as required, to prevent damaging build-up. WARRANTY COVERAGE MAY BE AFFECTED WITHOUT PROPER CLEANING.

HOW TO CLEAN THE UNIT:

	Soil	Cleaner	Method
CABINET Inside and Outside (Stainless Steel)	ROUTINE CLEANING	Soap, Ammonia, or mild *detergent and water.	1. Sponge on with cloth. 2. Rinse with water. 3. Wipe dry.
	STUBBORN SPOTS AND STAINS	Mild abrasive made for stainless steel.	1. Apply with damp sponge or cloth. 2. Rub lightly.
	BURNT-ON FOODS OR GREASE	Chemical oven cleaner for stainless steel.	Follow oven cleaner manufacturer's directions.
	HARD WATER SPOTS and SCALE	Vinegar	1. Swab or wipe with cloth. 2. Rinse and dry.

**Mild detergents include soaps and non-abrasive cleaners.*

Note: Gaskets are removable for cleaning.



BEFORE CLEANING CABINET:

1. Unplug power cord from wall.
2. Do NOT hose cabinet with water.
3. Do NOT get water on controls.
4. Do NOT use abrasives or harsh chemicals.

Cleaning hints:

1. Wipe up spills as soon as possible.
2. Clean cabinet regularly to avoid heavy dirt build-up.
3. Make a test spot with cleaner.
4. Follow manufacturer's directions on cleaner.
5. Do not mix cleaners.
6. Avoid drips and splashes.

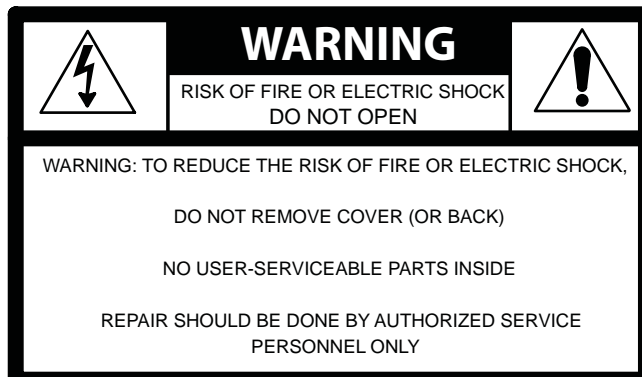

Pass-Thru Humidity Hot Cabinet	FL-2255
Rev. 13 (6/08)	Page 4 of 6

OPERATING and MAINTENANCE INSTRUCTIONS

Models: H137PWSUA...C & H138PWS1834C

Pass-Through Humidity Series Hot Cabinets

TROUBLE-SHOOTING CHART:

FAILURE	POSSIBLE CAUSE
1. <i>Yellow</i> light at switch does NOT light.	1a. Circuit breaker/fuse to wall outlet blown. 1b. Cord unplugged from wall outlet. 1c. Switch is “OFF”.
2. Unit does not heat.	2a. Thermostat set too low or is “OFF”. 2b. Switch is “OFF”.
3. Unit gets too hot or won't shut off.	3a. Defective electrical parts. UNPLUG UNIT FROM WALL OUTLET.
4. Blower does not work or makes noise.	4a. Defective blower.

If cause is none of the above, refer to our list of Authorized Service Centers, FL-1400

REPLACEMENT PARTS:

		<u>120V</u>	<u>208V</u>	<u>240V</u>
Power Unit	2000W	0675-003	0675-009	0675-009
	2000W + dig thrm	0675-003-D	0675-009-D	0675-009D
Heater Kit, Air	-2000W	0811-074		0811-074-01
Heater Kit, Water	-2000w	0811-271		0811-271
High Limit		0848-060	0848-060	0848-060
Thermometer	-analog	5238-030	5238-030	5238-030
	-digital	5238-034	5238-034	5238-034
Transformer <i>(used with digital thermometer)</i>		0769-159	0769-159	0769-159
Thermostat, air	-solid state	0848-008-ACK	0848-008-ACK	0848-008-ACK
Thermostat, water	-solid state	0848-008-ACK	0848-008-ACK	0848-008-ACK
Relay		0857-130	0857-102	0857-102
Power Cord	-2000w	0810-065-10	0810-039-02	0810-039-02
Power Switch		0808-116	0808-116	0808-116
Power Light		0769-094	0766-095	0766-095
Vent Fan		0769-165	0769-174	0769-174
Blower Kit		0769-180-01SSK	0769-182-01SSK	0769-182-01SSK
Door, complete	-stainless steel	UA12/UA6/1834	1221-520	
	-stainless steel	UA9		
Door, gasket	-stainless steel	UA12/UA6/1834	0861-185	
	-stainless steel	UA9	0861-182	
Door, hinge	-stainless steel		0519-074-K	

OPERATING and MAINTENANCE INSTRUCTIONS
Models: H137PWSUA...C & H138PWS1834C
Pass-Through Humidity Series Hot Cabinets

WIRING DIAGRAM 120V

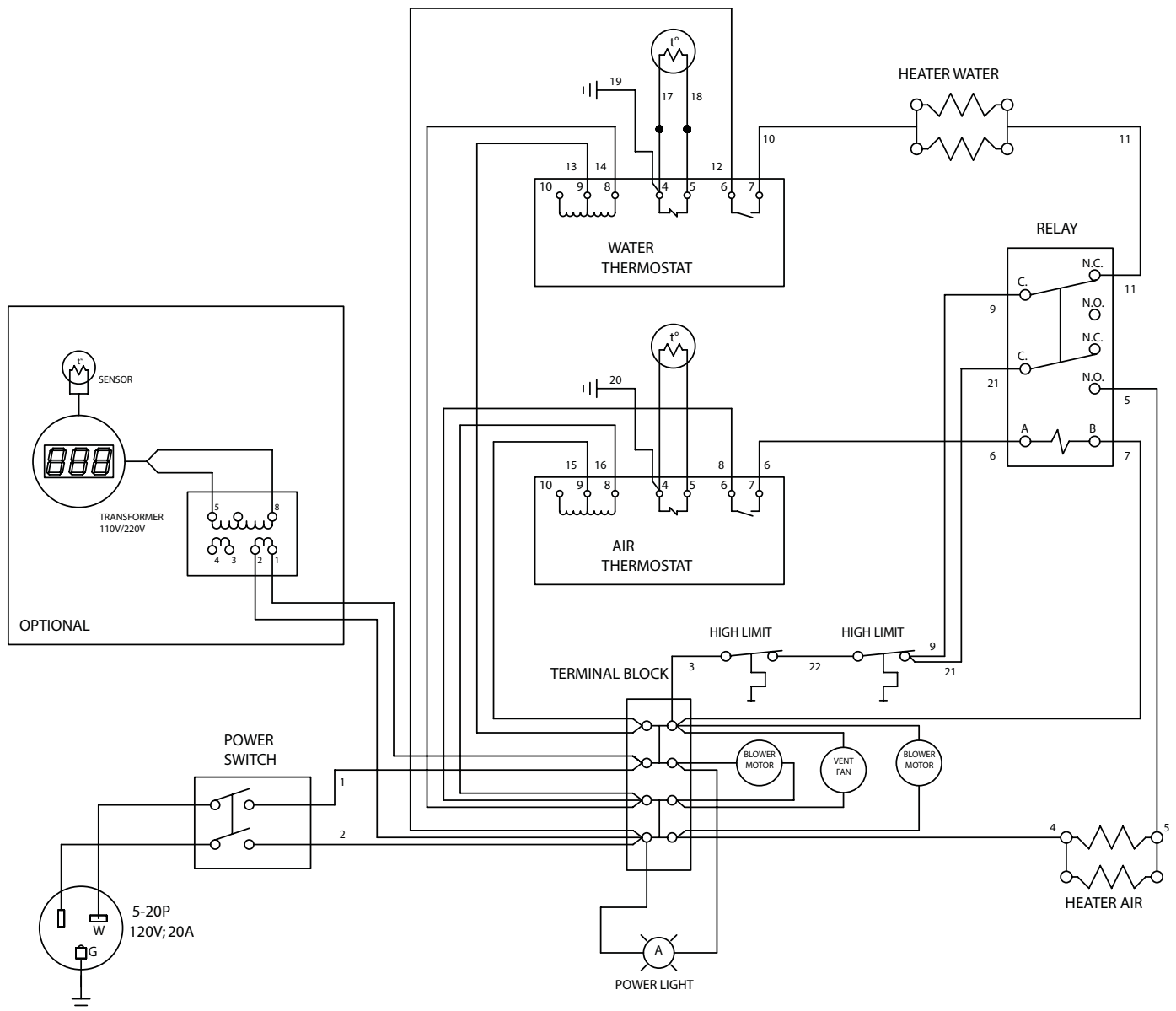

Pass-Thru Humidity Hot Cabinet	FL-2255
Rev. 13 (6/08)	Page 6 of 6

OPERATING and MAINTENANCE INSTRUCTIONS
Models: H137PWSUA...C & H138PWS1834C
Pass-Through Humidity Series Hot Cabinets
WIRING DIAGRAM 208V/240V

