

OPERATING and MAINTENANCE INSTRUCTIONS

Models: H137WSUA...C & H137WS18...C Series

Humidity Holding Hot Cabinet

ELECTRICAL SPECIFICATIONS:

Model No.	Volts	Watts	Amps	Hertz	Phase	NEMA
H137WSUA12C H137WSUA9C H137WSUA5C H137WSUA6C H138WS185C H138WS1834C H138WS1816C	120	2000	16.7	60	1	5-20P
H137WSUA12C208 H137WSUA9C208 H137WSUA5C208 H137WSUA6C208 H138WS185C208 H138WS1834C208 H138WS1816C208	208	2000	9.6	60	1	6-15P
H137WSUA12C240 H137WSUA9C240 H137WSUA5C240 H137WSUA6C240 H138WS185C240 H138WS1834C240 H138WS1816C240	240	2000	8.3	60	1	6-15P

NOTE: The above model numbers are basic models.

They may be followed by letters: **M, L, D** or ending with **S** and/or **Z**.

HOW TO INSTALL UNIT:

1. Place cabinet on level floor.
2. Plug cord end into proper wall outlet.
3. Fill water pan with 4 gallons (15 liters) of water.



Use of treated or soft water may be required for proper operation and to maintain warranty.

4. Place the cabinet in a well-ventilated area.
5. Push the switch to "On", turn the "Air" thermostat to No. 9 and run the unit for one hour.

NOTE: DO NOT PUT FOOD IN CABINET! This step is to burn off manufacturing oils and excess adhesive.

6. Let the cabinet cool and wipe inside clean with detergent and hot water before first use.



Air is VERY HOT when door is opened.

HOW TO PROOF:

1. Fill water pan with **HOT** water.
2. Turn power switch to "ON".
3. Turn "AIR" thermostat to "PROOF" (No. 1).
4. Turn "HUMIDITY" thermostat to No. 3½.
5. Preheat for ½ hour (30 minutes).
6. Put fresh or *fully thawed* dough into cabinet.

NOTE: Do **NOT** put in frozen dough.

NOTE: The optional digital thermometer display flashes when temperature in center of cabinet is below 140°F/60°C or above 250°F/121°C. Call the factory if you need different settings.

OPERATING and MAINTENANCE INSTRUCTIONS

Models: H137WSUA...C & H137WS18...C Series

Humidity Holding Hot Cabinet

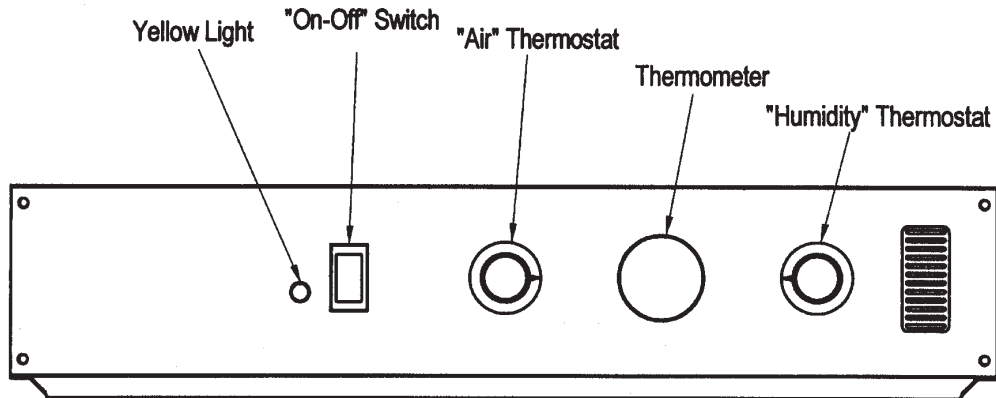

HOW TO HOLD:

No water is needed in pan.

1. Push power switch to "ON." Yellow light will come on.
2. Turn "AIR" thermostat to No. 9.
3. Preheat cabinet for 30 minutes.
4. Turn "AIR" thermostat to desired temperature.
(See thermostat settings below.)
5. Put product into cabinet.

HOW TO HOLD WITH HUMIDITY:

1. Fill water pan with HOT water.
2. Push power switch to "ON."
3. Turn the "AIR" Thermostat to No. 9.
4. Turn the "HUMIDITY" thermostat to No. 9.
5. Preheat for 30 minutes.
6. Turn "AIR" thermostat to desired temperature.
(See thermostat settings below.)
7. Put product into cabinet.

NOTES: 180°F/82°C is approximately No. 8. Proper food holding temperature is 140°F/60°C or higher.



WARNING

Air is VERY HOT when door is opened.

SOME TYPICAL THERMOSTAT SETTINGS:

THERMOSTAT SETTINGS		RESULT	
Air	Humidity	Cab. Temp.	Humidity
150° F	Off	150° F	N/A
Med Hold	Off	175° F	N/A
High Hold	Off	205° F	N/A
Maximum	Off	220° F	N/A
Proof	3½	100° F	98%
Low	Low	115° F	98%
Low	Med	150° F	95%
Low	High	150° F	95%
Low Hold	Low	160° F	30%
Low Hold	Med	160° F	50%
Low Hold	High	160° F	95%
Med Hold	Low	170° F	15%
Med Hold	Med	170° F	35%
Med Hold	High	170° F	85%
Med Hold	Max	170° F	90%
High Hold	Low	205° F	7%
High Hold	Med	205° F	15%
High Hold	High	205° F	40%
Maximum	Maximum	220° F	30%

Note: These settings are based on laboratory conditions and may differ from conditions at point of use. Experiment with the settings to determine what is best for your application.

OPERATING and MAINTENANCE INSTRUCTIONS
Models: H137WSUA...C & H137WS18...C Series
Humidity Holding Hot Cabinet

	WARNING	
RISK OF FIRE OR ELECTRIC SHOCK DO NOT OPEN		
WARNING: TO REDUCE THE RISK OF FIRE OR ELECTRIC SHOCK, DO NOT REMOVE COVER (OR BACK) NO USER-SERVICEABLE PARTS INSIDE REPAIR SHOULD BE DONE BY AUTHORIZED SERVICE PERSONNEL ONLY		

CAUTION

Delime or descale water pan parts as required, to prevent damaging build-up. WARRANTY COVERAGE MAY BE AFFECTED WITHOUT PROPER CLEANING.

WARNING

BEFORE CLEANING CABINET:

- 1. Remove Power Cord from cabinet.**
- 2. Do NOT hose cabinet with water.**
- 3. Do NOT get water on controls.**
- 4. Do NOT use abrasives or harsh chemicals.**

HOW TO TURN UNIT OFF:

Push switch to "OFF" Position.

MAINTENANCE: WATER PAN

Drain, wipe and fill water pan daily. (Clear vinyl drain hose is provided.)

1. Push hose onto drain nozzle under the base.
2. Turn knob to open the drain.

MAINTENANCE: CABINET

1. Wipe the inside of cabinet after daily use.
- 2. Leave doors slightly open to fully dry interior.**

Cleaning hints:

1. Wipe up spills as soon as possible.
2. Clean cabinet regularly to avoid heavy dirt build-up.
3. Make a test spot with cleaner.
4. Follow manufacturer's directions on cleaner.
5. Do not mix cleaners.
6. Avoid drips and splashes.

HOW TO CLEAN THE UNIT:

	Soil	Cleaner	Method
CABINET Inside and Outside (Stainless Steel)	ROUTINE CLEANING	Soap, Ammonia, or mild *detergent and water.	1. Sponge on with cloth. 2. Rinse with water. 3. Wipe dry.
	STUBBORN SPOTS AND STAINS	Mild abrasive made for stainless steel.	1. Apply with damp sponge or cloth. 2. Rub lightly.
	BURNT-ON FOODS OR GREASE	Chemical oven cleaner for stainless steel.	Follow oven cleaner manufacturer's directions.
	HARD WATER SPOTS and SCALE	Vinegar	1. Swab or wipe with cloth. 2. Rinse and dry.
*Mild detergents include soaps and non-abrasive cleaners.			

Note: Gaskets are removable for cleaning.

Insulated Hot Cabinets	FL-2253
Rev. 15 (6/08)	Page 4 of 6

OPERATING and MAINTENANCE INSTRUCTIONS

Models: H137WSUA...C & H137WS18...C Series

Humidity Holding Hot Cabinet

REPLACEMENT PARTS:

		<u>120V</u>	<u>208V</u>	<u>240V</u>
Power Unit	2000W	0675-003	0675-009	0675-009
	2000W + dig thrm	0675-003-D	0675-009-D	0675-009D
Heater Kit, Air	2000W	0811-268	0811-269	0811-270
	1000W	0811-074	0811-074-02	0811-074-1
Heater Kit, Water	1850W	0811-271		0811-271
High Limit		0848-060	0848-060	0848-060
Thermometer	Analog	5238-030	5238-030	5238-030
	Digital	5238-034	5238-034	5238-034
Transformer (<i>used with digital thermometer</i>)		0769-159	0769-159	0769-159
Thermostat, Air	Solid State	0848-008-ACK	0848-008-ACK	0848-008-ACK
Thermostat, Water	Solid State	0848-008-ACK	0848-008-ACK	0848-008-ACK
Relay		0857-130	0857-102	0857-102
Power Cord	2000W	0810-065-12	0810-039-07	0810-039-07
Power Switch		0808-116	0808-116	0808-116
Power Light		0766-094	0766-095	0766-095
Vent Fan		0769-165	0769-174	0769-174
Blower Kit		0769-180-K	0769-182-K	0769-182-K
Door, Complete (Stainless Steel)	UA12/UA6/1834/1816		1221-525	
	UA5/185		1221-545	
	UA9		1221-526	
Door, Gasket (Stainless Steel)	UA12/UA6/1834/1816		0861-185	
	UA5/185		0861-250	
	UA9		0861-182	
Door Hinge (Stainless Steel)			0519-074-K	
Door Latch	All Models		1006-122-01-K	

OPERATING and MAINTENANCE INSTRUCTIONS
Models: H137WSUA...C & H137WS18...C Series
Humidity Holding Hot Cabinet

WIRING DIAGRAM: 120V

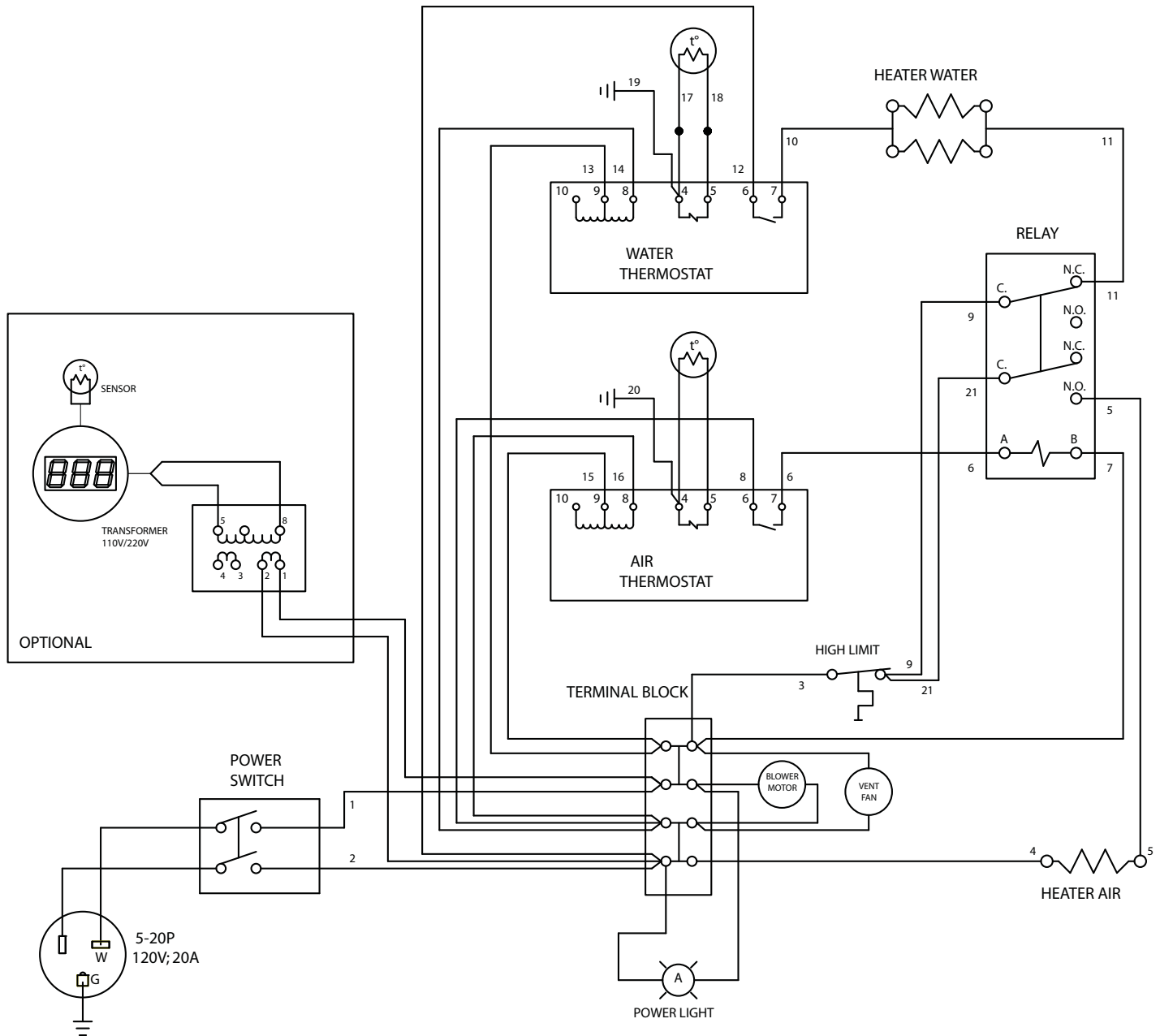

Insulated Hot Cabinets	FL-2253
Rev. 15 (6/08)	Page 6 of 6

OPERATING and MAINTENANCE INSTRUCTIONS
Models: H137WSUA...C & H137WS18...C Series
Humidity Holding Hot Cabinet

WIRING DIAGRAM: 208V/240V

