



5925 Heisley Road • Mentor, OH 44060-1833

Ovens	FL-2201-M
Rev. 5 (3/08)	Page 1 of 10

INSTALLATION, OPERATION and MAINTENANCE MANUAL for Cres Cor CONVECTION and RETHERM OVENS



CO151H189
CO151HUA6
RO151HUA9
(shown stacked)



CO151FUA12
RO151FUA18
CO151F1818



RO151F1336

Ovens	FL-2201-M
Rev. 5 (3/08)	Page 2 of 10

TABLE OF CONTENTS

SUBJECT	PAGE
INSTALLATION INSTRUCTIONS	3
OPERATING INSTRUCTIONS	4
MAINTENANCE INSTRUCTIONS	
How to Clean the Unit	5
Trouble Shooting Guide	6
Replacement Parts	6, 7
Illustrations; Hot Unit (Figures 3 and 4)	8
Wiring Diagram	9, 10
TIMER PROGRAMMING.....	FL-2222
SERVICE POLICY and AGENCY LIST	FL-1400

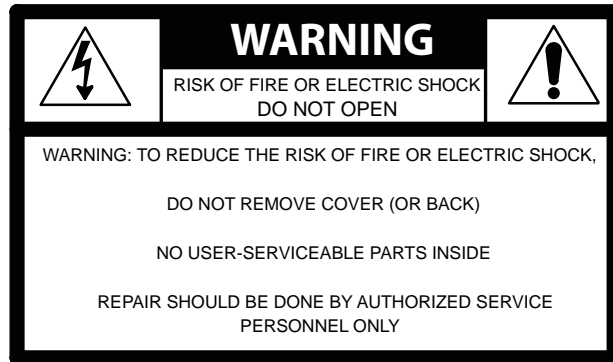

INSTALLATION INSTRUCTIONS

VENTING YOUR OVEN:

1. The purpose of ventilating hoods is to direct and capture smoke, grease-laden vapors, heat, odors, or fumes.
2. Low temperature equipment (maximum temperature 250°F/121°C) does not produce heat, odors, fumes, grease-laden vapors or smoke and is not required to be vented.
3. Most jurisdictions consider our low-temperature ovens (maximum temperature is 350°F/177°C) as low-heat appliances not requiring vent hoods.
4. Installation must conform with local codes. The authority having jurisdiction of enforcement of the codes will have the responsibility for making interpretations of the rules.

HOT UNIT SPECIFICATIONS:

MODELS with FOUR (4) HEATERS at 2000 Watts each (Total: 8200 Watts.)

MODEL NOS., All prefaced by HU18-671	ELECTRICAL SPECS (AC SERVICE)			ELEC. LOAD		POWER SUPPLY REQUIREMENT				
	Volts	Ph	Hz.	Amps	Volts	Amps	Ph	Wire	Volts	NEMA
-104, -121 & -123	240	1	60	34	240	50	1	3	240	6-50P
-103, -120 & -122	208	1	60	39	208	50	1	3	208	6-50P

MODELS with THREE (3) HEATERS at 2000 Watts each. (Total: 6200 Watts.)

-139 & -143	240	3	60	15	240	30	3	4	240	L15-30P
-138 & -142	208	3	60	17	208	30	3	4	208	L15-30P

MODELS with THREE (3) HEATERS at 1500 Watts each. (Total 4700 Watts.)

-125 & -127	240	1	60	20	240	30	1	3	240	6-30P
-137 & -124	208	1	60	23	208	30	1	3	208	6-30P
-141 & -145	240	3	60	12	240	20	3	4	240	L15-20P
-140 & -144	208	3	60	13	208	20	3	4	208	L15-20P

HOW TO INSTALL CABINETS:

1. Remove all packing material from inside cabinet.
2. Install the cabinet interior (pan slides).
3. Place hot unit (shipped separately) on the top of the cabinet.
4. Plug power cord into wall receptacle.



To install stacking units, refer to instruction sheet FL-2211, "STACKING INSTALLATION".

Ovens	FL-2201-M
Rev. 5 (3/08)	Page 4 of 10

OPERATING INSTRUCTIONS

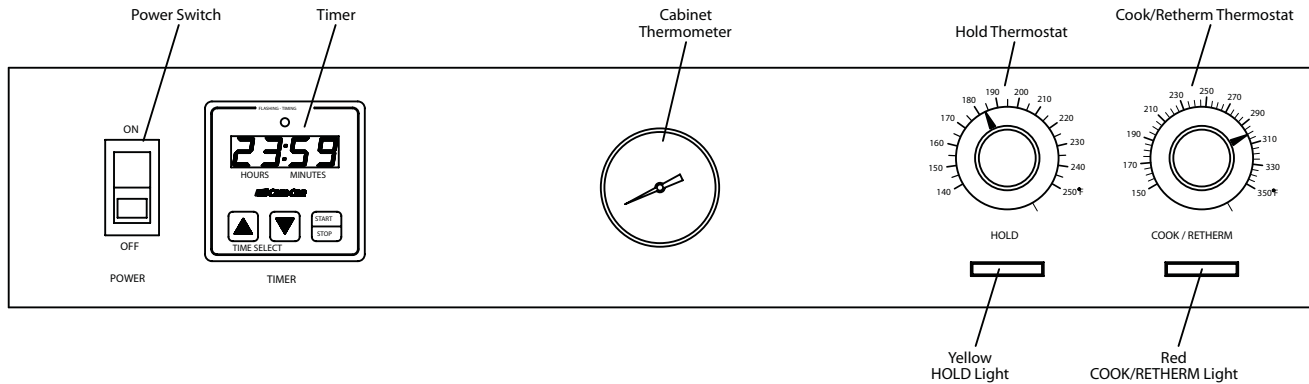

Figure 1: Control Panel
(For parts description, refer to page 7.)

HOW TO START UNIT: (for first-time operation only)

A new oven needs to “burn off” factory oils and glue before it’s first use. **Do NOT load food into oven until this has been done!**

1. Push power switch to “ON”.
2. Set *COOK/REThERM* thermostat to 350° F.
3. Set *HOLD* thermostat to 150° F.
4. Turn timer to one (1) hour.
5. Open door and move thumb screw on cabinet to open vent.
6. Allow oven to run automatically for one hour of *COOK/REThERM* cycle and 30 minutes of *HOLD* cycle.

HOW TO START UNIT (following “first-time” procedure above):

Push SWITCH “ON”.

For Automatic Operation:

1. Set *COOK/REThERM* thermostat to the cooking temperature you need.
2. Set *HOLD* thermostat to the warming temperature you need. Proper food-holding temperature is 140°F/60°C. or higher.
3. Set timer for the roasting time. The unit will automatically switch to the preset “hold” temperature after the roasting time has expired.

For Holding Operation ONLY:

1. Set *HOLD* thermostat to the temperature you need.
2. Set *TIMER* at zero.

Preheat:

Preheat oven for 30 minutes at the temperature setting you want before putting in the product.

To shut down unit:

Push ON/OFF switch to “OFF”.

NOTE: Ventilating fans will continue to run until cabinet is cool. At no time should the power supply to the cabinet be disconnected while the ventilating fan is still operating.

MAINTENANCE: HOW TO ADJUST DOOR LATCH:

1. For vertical (up and down movement) adjustment:
 - a. Loosen (2) screws located in magnetic strike.
 - b. Move strike up or down for alignment to magnet on latch.
 - c. Tighten screws to secure.
2. For horizontal adjustment
(greater or lesser magnetic draw):
 - a. Loosen (4) screws in door latch.
 - b. Move latch forward or backward to adjust magnetism.
 - c. Tighten screws to secure.

MAINTENANCE INSTRUCTIONS HOW TO CLEAN THE UNIT



CAUTION

1. ALLOW CABINET TO COOL.
2. REMOVE HOT UNIT *BEFORE* CLEANING.

- Wipe up spills as soon as possible.
- Clean regularly to avoid heavy dirt build-up.

Cleaning Hints:

1. Use the mildest cleaning procedure that will do the job.
2. Always rub in the direction of the polish lines to avoid scratching the surface.
3. Use only a soft cloth, sponge, fibrous brushes, plastic or stainless steel pad for cleaning and scouring.
4. Rinse thoroughly with fresh water after every cleaning operation.
5. Always wipe dry to avoid water marks.

HOW TO CLEAN THE UNIT:

	SOIL	CLEANER	METHOD
CABINET Inside and Outside (Stainless Steel)	ROUTINE CLEANING	Soap, ammonia or mild detergent* and water.	1. Sponge on with cloth 2. Rinse
	STUBBORN SPOTS, STAINS	Mild abrasive made for Stainless Steel.	1. Apply with damp sponge or cloth. 2. Rub lightly.
	BURNT ON FOODS OR GREASE	Chemical oven cleaner made for Stainless Steel.	Follow oven cleaner manufacturer's directions.
	HARD WATER SPOTS & SCALE	Vinegar	1. Swab or wipe with cloth. 2. Rinse and dry.

* *Mild detergents include soaps and non-abrasive cleaners*

MAINTENANCE INSTRUCTIONS TROUBLE-SHOOTING GUIDE



WARNING

IF UNIT GETS TOO HOT OR WON'T SHUT OFF, DISCONNECT POWER AT BRANCH PANEL. DO NOT UNPLUG CORD!

If hot unit is *NOT* working, first check the following causes:

- | | |
|--|---|
| <ol style="list-style-type: none"> 1. Cord is unplugged from wall outlet. 2. Circuit breaker/fuse to wall outlet is blown. | <ol style="list-style-type: none"> 3. Switch is turned off. 4. Thermostat is turned off, or is set too low. |
|--|---|

Ovens	FL-2201-M
Rev. 5 (3/08)	Page 6 of 10



MAINTENANCE INSTRUCTIONS TROUBLE-SHOOTING GUIDE, *continued*

PROBLEM	POSSIBLE CAUSE	SOLUTION
Cabinet does not heat, or doesn't heat properly	1. Fuse 2. Thermostat 3. Heater contactor 4. Loose wiring at heater contactor 5. Hi-limit switch 6. On/Off Switch	1. Replace 2. Replace 3. Replace 4. Replace 5. Replace 6. Replace
Blowers do not operate	1. On/Off Switch 2. Fuse 3. Blower	1. Replace 2. Replace 3. Replace
Heaters will not shut off	1. Thermostat 2. Contactor	1. Replace 2. Replace
Vent fans do not shut off (See Note)	1. Vent fan switch defective 2. Control compartment is still hot.	1. Replace 2. Wait until it cools 3. Check "Heater will not shut off"
Vent fans do not operate (See Note)	1. Fuse 2. Vent fan switch defective 3. Vent fan defective	1. Replace 2. Replace 3. Replace

NOTE: Vent fans will not operate until the control compartment requires ventilation to limit temperatures. Replacement of electrical components must be done by a qualified electrician. Refer to our *Service Agency list, FL-1400* (found in the back of this manual), of authorized service centers. Instructions for replacing parts are included in replacement parts list.

REPLACEMENT PARTS: Include all information on nameplate when ordering parts.

Cabinet Replacement Parts

MODEL PREFIX CO-151 or RO-151					
DESCRIPTION	-1336	-FUA (12, 18)	-F18 (18)	-H18 (9)	-HUA (6, 9)
Hot Unit, 208V, 1 Ph	HU18671103	HU18671120	HU18671122	HU18671124	HU18671137
Hot Unit, 240V, 1 Ph	HU18671104	HU18671121	HU18671123	HU18671125	HU18671127
Hot Unit, 208V, 1 Ph	---	HU18671138	HU18671142	HU18671144	HU18671140
Hot Unit, 240V, 3 Ph	---	HU18671139	HU18671143	HU18671145	HU18671141
Door Latch Kit	1006-120-01-K	1006-120-01-K	1006-120-01-K	1006-120-01-K	1006-120-01-K
Door Latch Strike	1006-120-02-K	1006-120-02-K	1006-120-02-K	1006-120-02-K	1006-120-02-K
Door Hinge	0519-074-K	0519-074-K	0519-074-K	0519-074-K	0519-074-K
Door Assembly	1221-380-K	1221-416-K	1221-417-K	1221-417-K	1221-416-K
Door Gasket	0861-184	0861-185-K	0861-197-K	0861-197-K	0861-185-K
Rack Insert	1104-080	---	1104-082	1104-082	---
Universal Angles (set of 2)	---	0621-238-K	---	---	0621-238-K

REPLACEMENT PARTS, continued
Include all information on nameplate when ordering parts

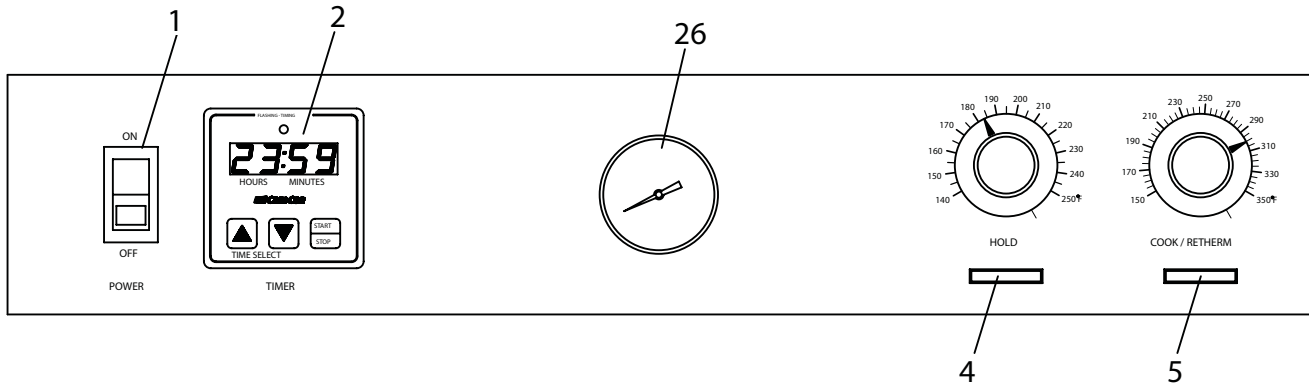

FIGURE 2: CONTROL PANEL

Hot Unit Replacement Parts

ITEM DESCRIPTION

ITEM DESCRIPTION	Part No.
1. Switch (On/Off)	0808-113-01-K
2. Timer, Digital with Transformer	0849-088-K2
3. Knob, Thermostat	0595-061
4. Pilot Light, Yellow	0766-081
5. Pilot Light, Red	0766-080
6. Thermometer	5238-031
7. Vent Fan	0769-174
8. Fan Guard	0769-167
9. Fuse	0807-058
Fuse Holder	0807-048
10. Blower Kit	0769-182-K
11. Control Board	0848-057-K3
Potentiometer Only	0848-057-04
12. Contactor	0857-026
13. Terminal Block, Front	0852-091
14. Terminal Block, Center	0852-093
15. Timer, Fan	0849-089
16. Transformer	0769-159
17. Relay, Timer	0857-102
18. Relay, Blower	0857-103
19. Hi-Limit (Switch)	0848-033
20. Sensor Only	0848-058-K1
Sensor Bushing	0818-006
26. Thermometer	5238-031
Gasket, Hot Unit	0861-161-K

ITEM DESCRIPTION

ITEM DESCRIPTION	Part No.
PARTS for 8200W, 1-PH UNITS	
21. Terminal Block, Rear	0852-090
22. Power Cord	0810-124
23. Heater Kit, 208V	0811-185-K
Heater Kit, 240V	0811-023-K
Wire Harness Kit	5812-907
24. Strain Relief	0818-061
25. Plug	0840-033
PARTS for 6200W, 3-PH UNITS	
21. Terminal Block, Rear	0852-107
22. Power Cord (Pass-thru)	0810-162
23. Heater Kit, 208V	0811-185-K
Heater Kit, 240V	0811-023-K
24. Strain Relief	0818-050
25. Plug	0840-049
Wire Harness Kit	5812-908
PARTS for 4700W, 1-PH UNITS	
21. Terminal Block, Rear	0852-107
22. Power Cord	0812-465-72
23. Heater Kit, 208V	0811-020-01-K
Heater Kit, 240V	0811-020-K
24. Strain Relief	0818-050
25. Plug	0840-031
Wire Harness Kit	5812-907
PARTS for 4950W, 3-PH UNITS	
21. Terminal Block, Rear	0852-107
22. Power Cord	0812-574-2
23. Heater Kit, 208V	0811-020-01-K
Heater Kit, 240V	0811-020-K
24. Strain Relief	0818-050
25. Plug	0840-048
Wire Harness Kit	5812-908

Ovens	FL-2201-M
Rev. 5 (3/08)	Page 8 of 10

REPLACEMENT PARTS, *continued*
Include all information on nameplate when ordering parts

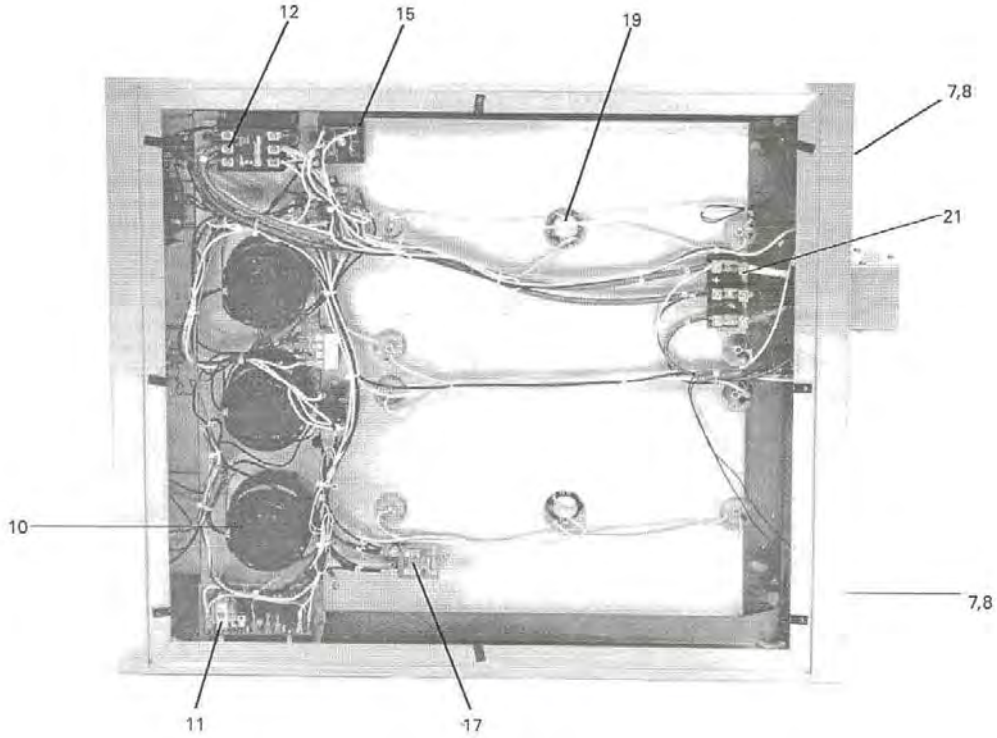

FIGURE 3; Hot Unit w/o Top Cover
 (For parts description, refer to page 7)

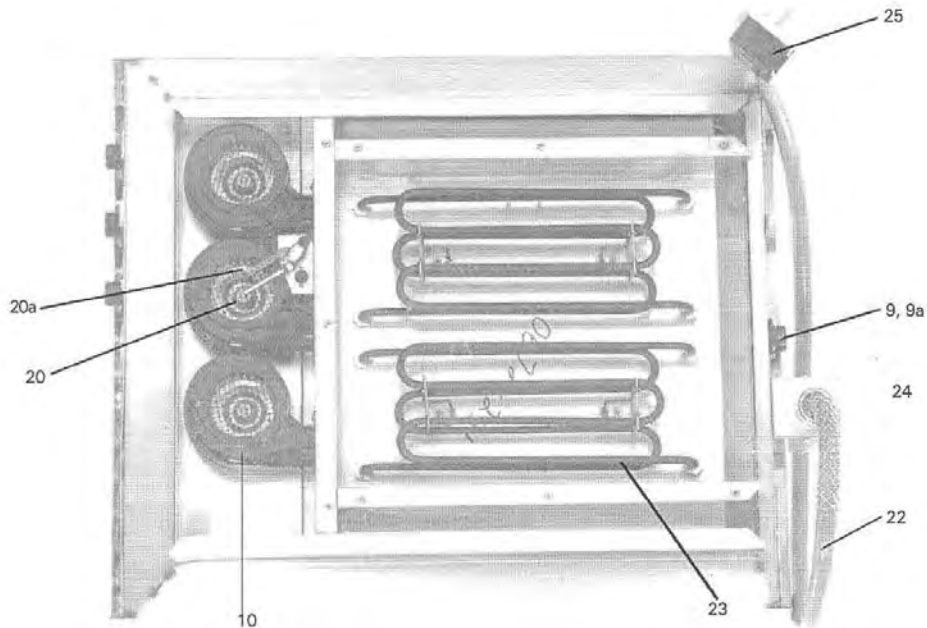
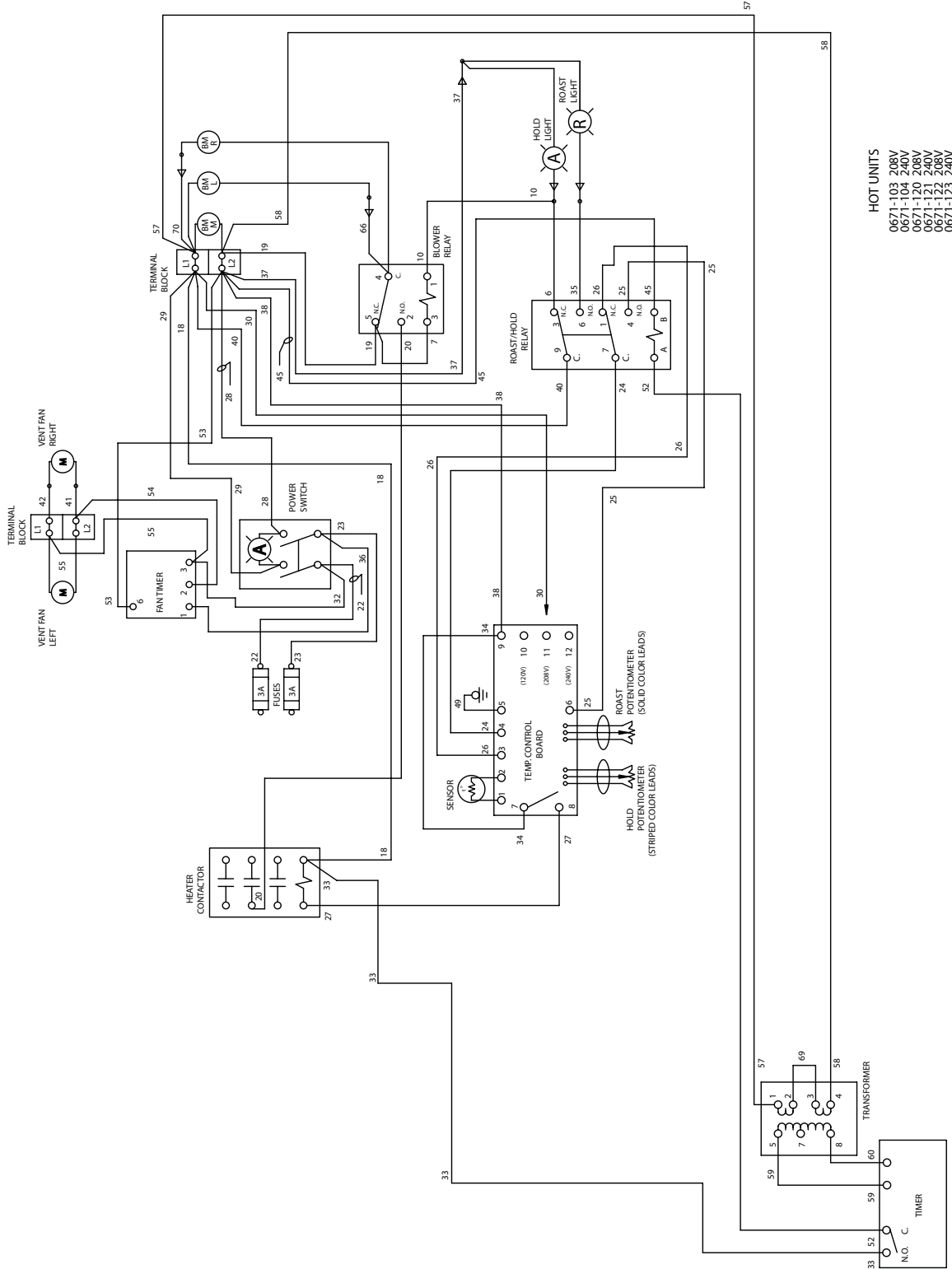

FIGURE 4; Bottom of Hot Unit, Cover Removed
 (For parts description, refer to page 7)

WIRING DIAGRAM



HOT UNITS
 0671-103 208V
 0671-104 240V
 0671-110 208V
 0671-121 240V
 0671-122 208V
 0671-123 240V

Ovens	FL-2201-M
Rev. 5 (3/08)	Page 10 of 10

WIRING DIAGRAM (continued)

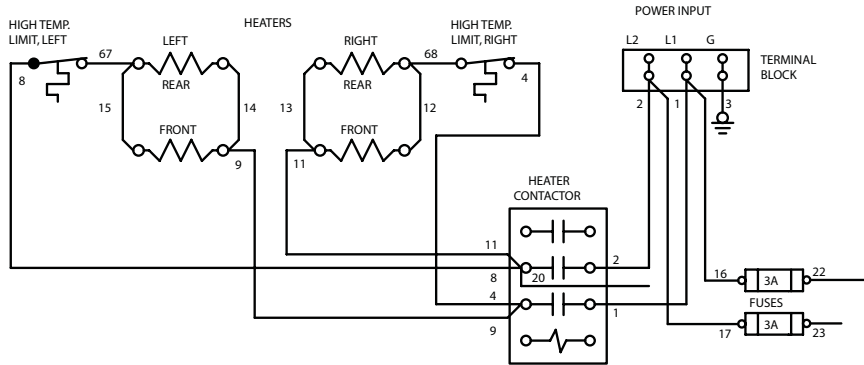

8200W, SINGLE PHASE

WIRE KIT [5812-907](#)

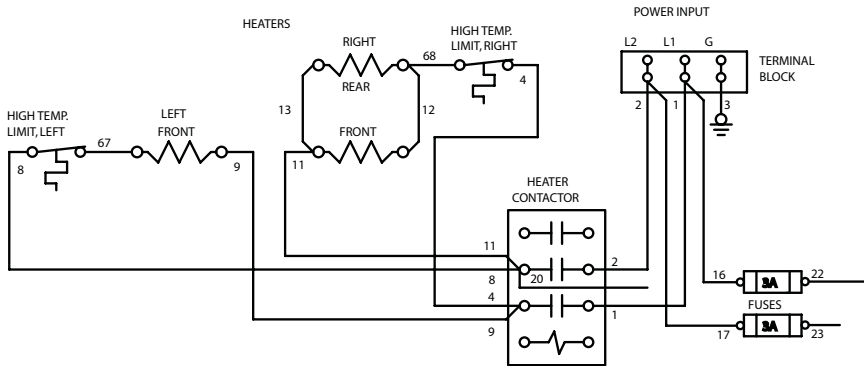

4700W, SINGLE PHASE

WIRE KIT [5812-907](#)

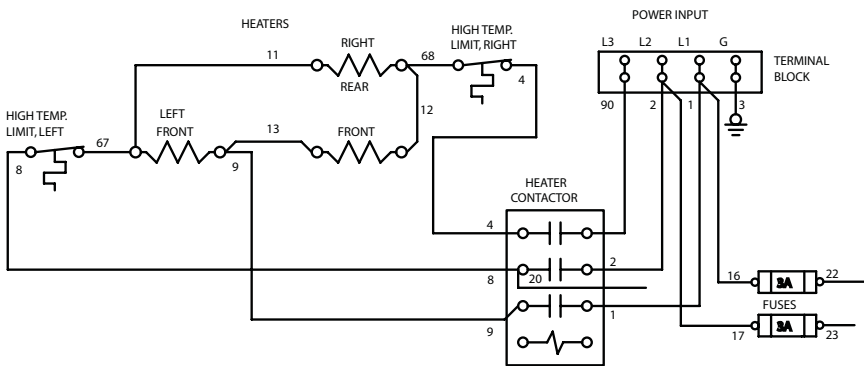

6200W & 4700W, 3 PHASE

WIRE KIT [5812-908](#)