

INSTALLATION, OPERATION and MAINTENANCE MANUAL for *CRES COR* UNDERCOUNTER OVENS with MICROPROCESSOR CONTROLS 2000 WATTS



**CO151XUA5B
CO151X185B**

SANITATION
CLASSIFIED



CLASSIFIED TO
NSF4



C

TABLE OF CONTENTS

SUBJECT	PAGE
INSTALLATION INSTRUCTIONS	3
OPERATING INSTRUCTIONS	4, 5
Illustration, Figure 1	4
MAINTENANCE INSTRUCTIONS	
How to Clean the Unit	6
Trouble Shooting Guide	6, 7
Replacement Parts	8, 9
Illustrations; Hot Unit	9
Wiring Diagrams	10
STACKING INSTRUCTIONS	FL-2211
TIMER PROGRAMMING	FL-2222
SERVICE POLICY and AGENCY LIST	FL-1400

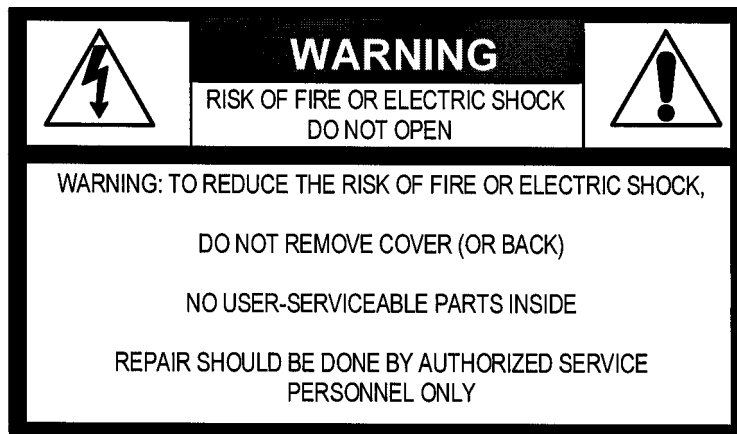

INSTALLATION INSTRUCTIONS:

VENTING YOUR OVEN:

1. The purpose of ventilation hoods is to direct and capture smoke, grease-laden vapors, heat, odors, or fumes.
2. Low temperature equipment (maximum temperature 250°F/121°C) does not produce heat, odors, fumes, grease laden vapors or smoke and is not required to be vented.
3. Most jurisdictions consider our low-temperature ovens (maximum temperature is 350°F/177°C) as low-heat appliances not requiring vent hoods.
4. Installation must conform to local codes. The authority having jurisdiction of enforcement of the codes will have the responsibility for making interpretations of the rules.

ELECTRICAL SPECIFICATIONS:

Model Nos.	Volts	Watts	Amps	Hertz	Ph	NEMA
CO-151-XUA-5B-1201-Q1	120	2000	16.6	60	1	5-20P
CO-151-X-185B-1201-Q1	120	2000	16.6	60	1	5-20P

*All models are designed for AC Service.
Model numbers may have the letters: L, M, T, or S.*

HOW TO INSTALL CABINETS:

1. Remove all packing material from inside and outside of cabinet.
2. Position cabinet on level floor; install the cabinet interior (pan slides) if not already installed.
3. Plug power cord into proper wall receptacle.

NOTES: Cold food is **NOT** to be added when unit is operating in **HOLD** mode.

For **HOLD** mode, preheat unit to 180°F/82°C for 60 minutes.



To install stacking units, refer to instruction sheet FL-2211, *STACKING INSTALLATION*.

OPERATING INSTRUCTIONS:

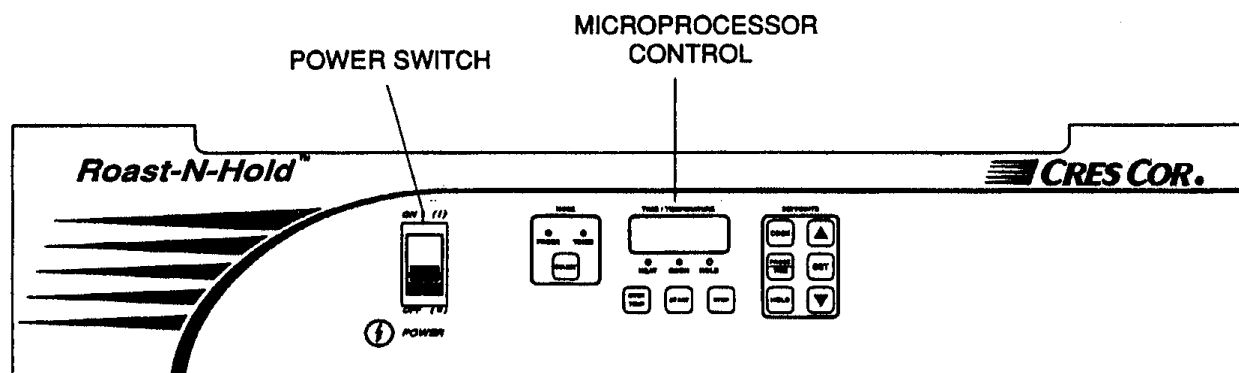

Figure 1: Control Panel

HOW TO START UNIT:

(for first-time operation only)

A new oven needs to “burn off” factory oils and glue before it’s first use. **Do NOT load food into oven until this has been done!**

1. Push power switch to “ON”.
2. Press the SELECT button; choose the TIMED mode.
3. Press the **COOK** button and set the temperature to 350°F/177°C.
4. Press the **HOLD** button and set the temperature to 150°F/66°C.
5. Press the PROBE/TEMP button and set the timer to one (1) hour.
6. Allow oven to run automatically for one (1) hour of **COOK/RETERM** cycle and 30 minutes of **HOLD** cycle.

HOW TO SET THE CONTROL FOR TIMED COOK OPERATION:

Press the SELECT button to choose the TIMED mode.

COOKING TIME:

1. Press the PROBE/TIME button. The display will show the cook/retherm time.
2. Use the UP and DOWN arrows to set the desired time.
3. Press the SET button to enter the time into the control.

COOKING TEMPERATURE:

1. Press the COOK button and the display will show the cook/retherm temperature.
2. Use the UP and DOWN arrows to set the desired temperature.
3. Press the SET button to enter the temperature into the control.

NOTE: Press the OVEN TEMP button at any time to view the actual oven temperature.

HOLDING TEMPERATURE:

1. Press the HOLD button; the display will show the holding temperature.
2. Use the UP and DOWN arrows to set the desired temperature.

NOTE: Proper food holding temperature is 140°F/60°C or higher.

3. Press the SET button to enter the temperature into the control.
4. Press the START button and the display shows the remaining time in the cook/retherm cycle.

NOTES: The control will beep after it times down to zero; it will then automatically switch to the HOLD mode. The display will then show the hold setpoint temperature.

For HOLD mode, preheat unit to 180°F/82°C for 60 minutes.

OPERATING INSTRUCTIONS, continued:

HOW TO SET THE CONTROL, continued FOR PROBE COOK OPERATION:

Press the SELECT button to choose the probe mode.

PROBE TEMPERATURE:

1. Press the PROBE/TIME button. The display will show the probe setpoint temperature.
2. Use the UP and DOWN arrows to set the desired temperature.
3. Press the SET button to enter the temperature into the control.

NOTE: Press the OVEN TEMP button at any time to view the actual oven temperature.

NOTE: The control will beep when the probe setpoint temperature has been reached and then will automatically switch to HOLD mode. The display will then show the hold setpoint temperature.

To manually end the COOK/RETERM, PROBE, or HOLD mode:

Press the STOP button during any of the above modes and the control will end that mode. If in the Cook/Retherm or Probe mode, the control will automatically switch into the HOLD mode.

HOW TO OPERATE WITH FOOD:

Manual (Timed mode) Operation

See “HOW TO SET CONTROL” (on page 4) for programming instructions.

1. Push power switch to “ON”.
2. Press the SELECT button and choose the TIMED mode.
3. Press the COOK button and set to desired temperature.
4. Press the PROBE/TIME button and set to the desired time.
5. Press the HOLD button; set desired temperature.
6. Place the food into oven. Close door and double check cooking time and temperatures. Then press the START button to start the cooking/retherm cycle and the Cook LED will light up.

7. The oven will beep and automatically switch to the HOLD mode at the end of the cooking cycle. The Cook lamp will go out and the Hold lamp will light up.

Probe Cooking

See “HOW TO SET CONTROL” (on page 5) for programming instructions.

1. Push power switch to “ON”.
2. Press the SELECT button and choose the Probe mode.
3. Insert the probe jack into the receptacle located inside the oven top, near the fans. The probe temperature display will show the digital temperature of the probe.
4. Put sanitized probe into center of food product. Make sure food is in the center of the pan and the pan is centered in the oven.
5. Press the start button. The cook lamp will light up and the display will show the internal temperature of the food being cooked.

NOTE: Do NOT change the mode of the controls (probe or timed) while oven is operating in a Cook/Retherm cycle. Oven must be in the HOLD cycle to change the timer or probe operation.

HOW TO SET HOLD-ONLY MODE:

1. Push power switch to “ON”.
2. Press the STOP button and the oven will switch to HOLD cycle.
3. Press the HOLD button and set the desired hold temperature.

HOW TO SHUT DOWN OVEN:

Push switch to “OFF”.

CAUTION: Ventilating fans will continue to run until the cabinet is cool. Do NOT disconnect the power supply to the cabinet while the ventilating fan is still operating.

MAINTENANCE INSTRUCTIONS

WARNING!

BEFORE cleaning the cabinet:

1. Unplug cord from wall. Allow cabinet to cool.
2. Do NOT hose cabinet with water.
3. Do NOT get water on controls.
4. Do NOT use abrasives or harsh chemicals.

- Wipe up spills as soon as possible.
- Clean regularly to avoid heavy dirt build-up.

HOW TO CLEAN THE UNIT:

Cleaning Hints:

1. Use the mildest cleaning procedure that will do the job.
2. Always rub in the direction of polish lines to avoid scratching the surface.
3. Use only a soft cloth, sponge, fibrous brushes, plastic or stainless steel pads for cleaning and scouring.
4. Rinse thoroughly with fresh water after every cleaning operation.
5. Always wipe dry to avoid water marks.

	SOIL	CLEANER	METHOD
CABINET Inside and Outside (Stainless Steel)	Routine Cleaning	Soap, ammonia or mild detergent* and water.	1. Sponge on with cloth 2. Rinse
	Stubborn Spots, Stains	Mild abrasive made for Stainless Steel.	1. Apply with damp sponge or cloth. 2. Rub lightly.
	Burnt on Foods or Grease	Chemical oven cleaner made for Stainless Steel.	Follow oven cleaner manufacturer's directions.
	Hard Water Spots & Scale	Vinegar	1. Swab or wipe with cloth. 2. Rinse and dry.
<i>*MILD DETERGENTS INCLUDE SOAPS AND NON-ABRASIVE CLEANERS.</i>			

MAINTENANCE INSTRUCTIONS TROUBLE-SHOOTING GUIDE

WARNING!

IF UNIT GETS TOO HOT OR WON'T SHUT OFF, DISCONNECT POWER AT BRANCH PANEL. DO NOT UNPLUG CORD!

If hot unit is *NOT* working, first check the following causes:

- | | |
|--|---|
| <ol style="list-style-type: none"> 1. Cord is unplugged from wall outlet. 2. Circuit breaker/fuse to wall outlet is blown. | <ol style="list-style-type: none"> 3. Switch is turned off. 4. Thermostat is turned off, or is set too low. |
|--|---|

MAINTENANCE INSTRUCTIONS TROUBLE-SHOOTING GUIDE, *continued*

PROBLEM	POSSIBLE CAUSE	SOLUTION
Cabinet does not heat, or doesn't heat properly	1. Thermostat 2. Heater relay 3. Loose wiring at heater relay 4. Hi-limit switch 5. On/Off switch	1. Replace 2. Replace 3. Replace 4. Replace 5. Replace
Blowers do not operate	1. On/Off Switch 2. Blower	1. Replace 2. Replace
Heater will not shut off	1. Thermostat 2. Relay	1. Replace 2. Replace
Vent fan does not shut off	1. Vent fan switch 2. Control compartment still hot	1. Replace 2. Wait until it cools Check " <i>Heaters will not shutoff</i> "
Vent fan does not operate	1. Vent fan switch 1. Vent fan	1. Replace 2. Replace
Control will not switch from "COOK" to "HOLD" (timer mode)	1. Oven is in "PROBE" mode. 2. Control is defective	1. Switch to "TIMED" mode 2. Replace
Control will not switch from "COOK" to "HOLD" (probe mode)	1. Oven is in the "TIMED" mode 2. Probe not plugged in 3. Control is defective	1. Switch to "PROBE" mode 2. Plug in probe 3. Replace
Control will not switch to "COOK" (probe mode)	1. Oven in "TIMED" mode 2. Probe temperature setting lower than probe temperature 3. Probe not plugged in 4. Control defective	1. Switch to "PROBE" mode 2. Set probe temperature to desired temperature 3. Plug in probe 4. Replace

NOTE: Vent fans will not operate until the control compartment requires ventilation to limit temperatures. Replacement of electrical components must be done by a qualified electrician. Refer to our *Service Agency list, FL-1400* (found in the back of this manual), of authorized service centers. Instructions for replacing parts are included in replacement parts list.

REPLACEMENT PARTS:

Include all information on nameplate when ordering parts.

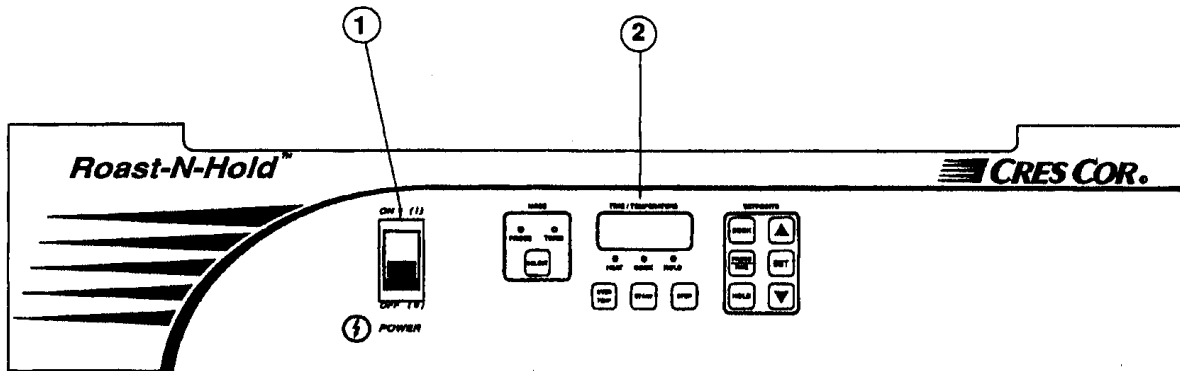

FIGURE 2: CONTROL PANEL

Hot Unit Replacement Parts

ITEM DESCRIPTION	CMP Part No.	ITEM DESCRIPTION	CMP Part No.
1. Switch (On/Off)	0808-113	11. Terminal Block, Front	0852-096
2. Timer, Digital	0849-088	12. Terminal Block	0852-093
3. Knob, Thermostat	0595-061	13. Switch, Fan	0848-034
3. Control Board	0848-057-K3	14. Relay – Timer	0857-100
4. Pilot Light, Yellow	0766-094	15. Hi-Limit (Switch)	0848-079
5. Pilot Light, Green	0766-098	16. Sensor	0848-058-K1
6. Thermometer	5238-031	17. Sensor Bushing	0818-014
7. Vent Fan	0769-165	18. Transformer	0769-159
8. Fan Guard	0769-167	19. Power Cord	0810-039-06
9. Blower Kit	0769-005-K	20. Heater Kit	0811-022
10. Relay	0857-130	21. Strain Relief	0818-057

Cabinet Replacement Parts

DESCRIPTION	MODEL PREFIX CO-151 ("Q" Series)	
	-XUA5B-Q1	-X185B-Q1
Hot Unit, 120V, 1 Ph	HU675045Q1	HU675046Q1
Door Latch Kit	1006-120-01	1006-120-01
Latch Strike Kit	1006-120-02	1006-120-02
Door Hinge	0519-074	0519-074
Door Assembly	1221-545	1221-546
Door Gasket	0861-250	0861-251
Interior	0621-281	1104-107
Casters	0569-310	0569-310
Casters w/brake	0569-310B	0569-310B

REPLACEMENT PARTS:

Include all information on nameplate when ordering parts.

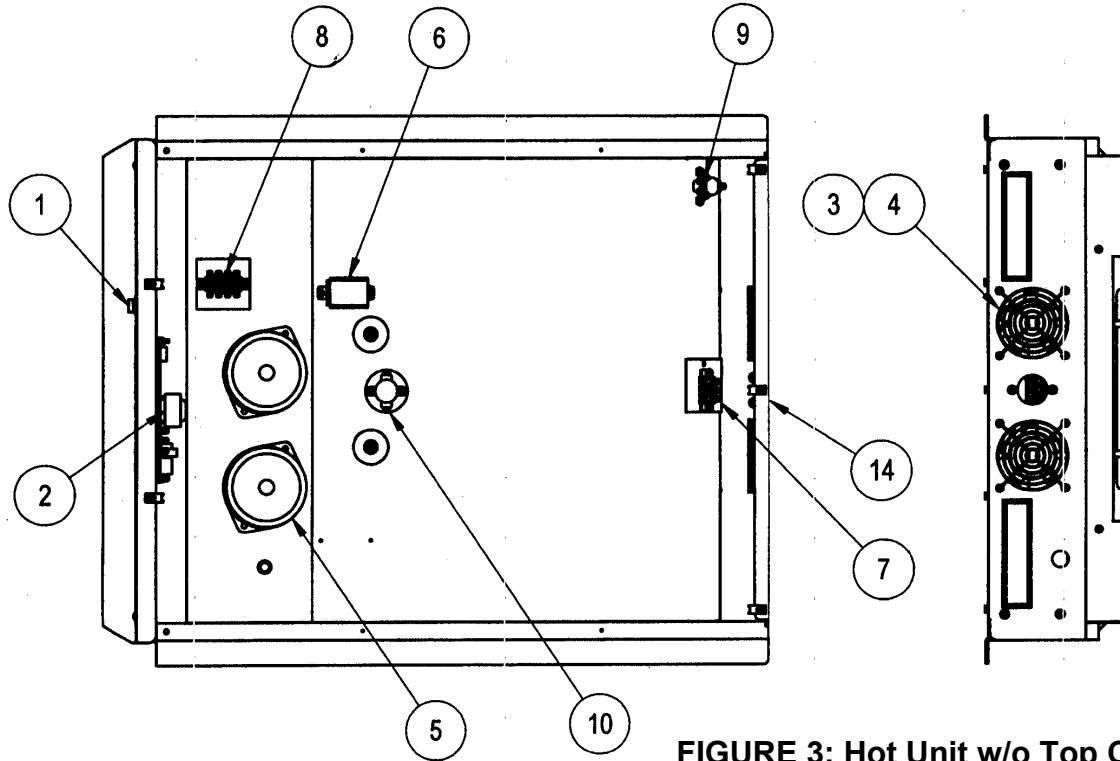

FIGURE 3; Hot Unit w/o Top Cover
 (For parts description, refer to page 8.)

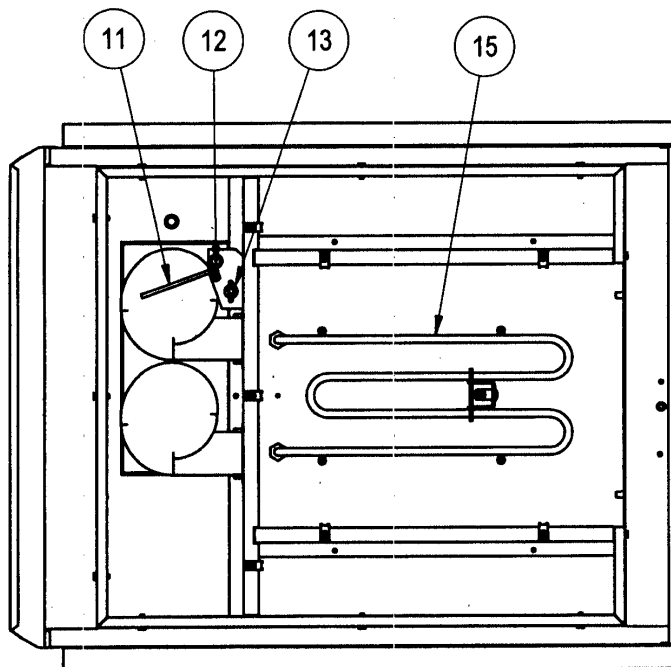

FIGURE 4; Bottom of Hot Unit Cover Removed
 (For parts description, refer to page 8.)

WIRING DIAGRAM

