

QUICK START GUIDE for Cres Cor Outback Steakhouse Ovens

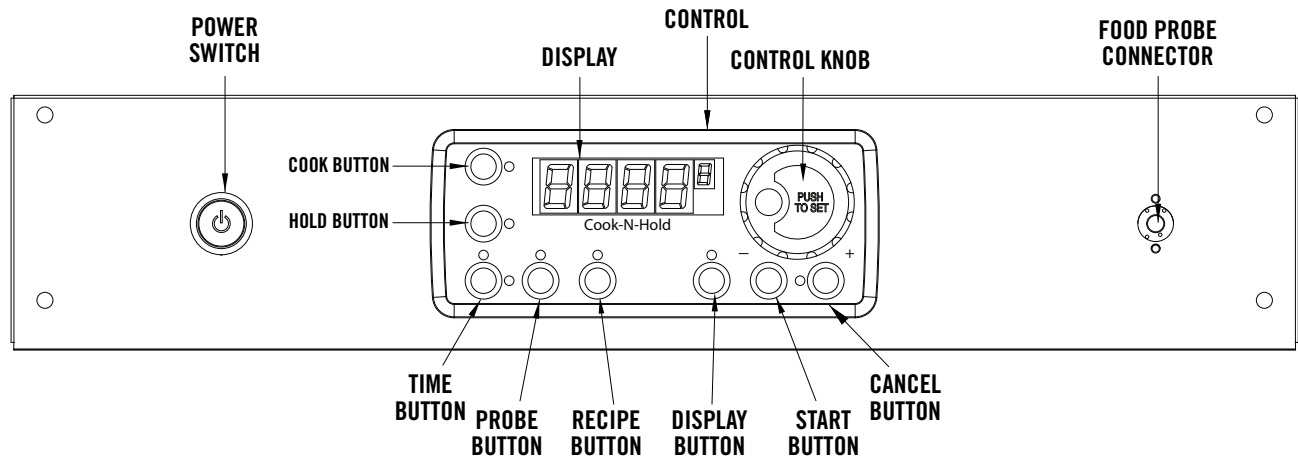

HOW TO START:

1. Push the lighted power switch to start the oven. This will initiate the oven in a "HOLD" mode.
2. The display will read "LOTPR" (low temperature) until the oven reaches 140°F. (60°C.).

NOTE: Allow one (1) hour after start up (preheat) before loading the food for best results.

3. Plug probe into the probe jack on the face of the oven. (This unit comes with 2 probes: A 6" probe for Prime Rib and a 3" probe for other items. See Figure 1.)

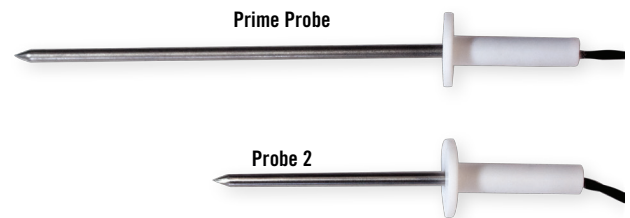

FIGURE 1

TO SELECT A RECIPE:

1. Push the Recipe Button. Use the control knob to select Menu 1 for Prime Rib.
2. Once recipe is selected, push the Control Knob to confirm your selection. The display will read "PREHT" until the cabinet reaches the set temperature, then it will show "PUSH START".
3. Insert probe spike into the center of the meat and load into oven.

NOTE: The probe lead should exit oven cavity near the plug jack to prevent kinking.

4. Close the cabinet door.

5. Push the Start Button to begin the cooking cycle. The indicator light next to the Cook Button will illuminate, along with the Probe Button and Recipe Button indicator lights.
6. The oven will now cook the meat until the preselected probe temperature is reached. At that point, the oven will go into HOLD mode and the indicator light illumination will move from the Cook Button to the Hold Button.
7. Upon completion of the recommended hold time, disconnect the probe and remove the meat for processing.
8. Sanitize probe and lead and store for future use. You can now start a new recipe as illustrated in Step 1.

NOTE: To cancel program at any time, press the Cancel Button. This will cancel the program and allow operator to change operations.

Ovens	FL-2374-D-OB
Rev. 0 (10/17)	Page 2 of 17

SENSOR RETROFIT INSTRUCTIONS for OUTBACK STEAKHOUSE OVENS

PARTS INCLUDED:

- New sensor assembly (sensor, clamp, bracket, screw)
- Mounting screw #8 x 3/8"
- Silicone grommet
- Pin remover tool
- Zip ties
- Instruction sheet

INSTRUCTIONS:

1. Unplug unit and pull out to access the top of unit.
2. Remove 10 screws securing top cover and slide cover back to access the front of the control compartment.
3. Locate sensor's white wires running to the control, cut zip ties securing those wires (if applicable).

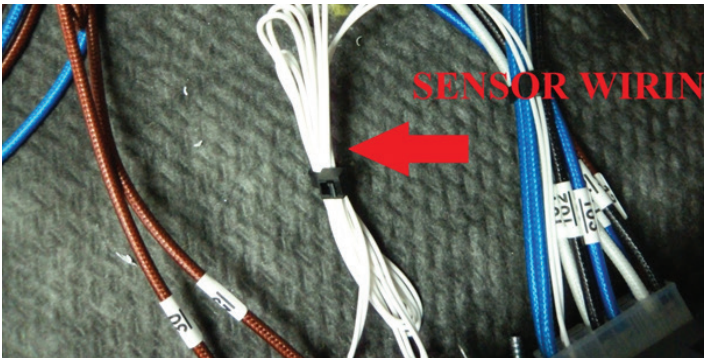

4. Unplug white 16-pin connector from the back of the control. Note small tab on bottom center must be depressed.
5. Insert pin remover tool into pin on "front" of connector, pull wires out "back" of connector so they are loose.

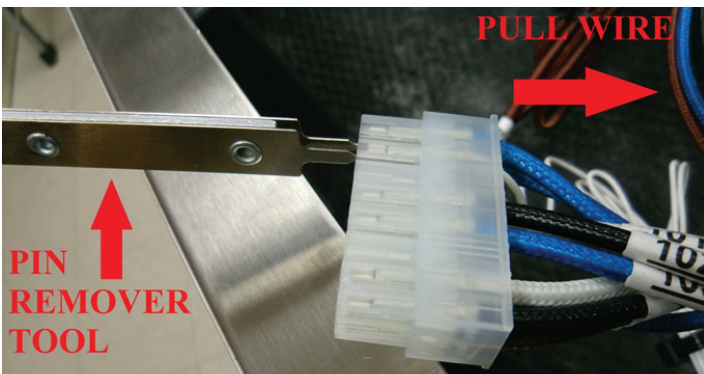

6. From inside cooking compartment, remove mounting screw and remove sensor from oven. Retain screw.



7. Replace screw back into riv-nut to fill the hole so there is no opening in the interior compartment.
8. Remove any excess silicone RTV sealant from through-hole (where wires came through).
9. Carefully place new silicone grommet into through hole.
10. On new sensor assembly, verify distance between back of clamp and back of sensor sheath is 1.5". (750-CH models)



11. From the top, carefully place sensor down through the through-hole and into the grommet.
12. Sensor should be protruding into the cooking compartment approximately 1.25"

(Continued on next page.)

SENSOR RETROFIT INSTRUCTIONS for OUTBACK STEAKHOUSE OVENS

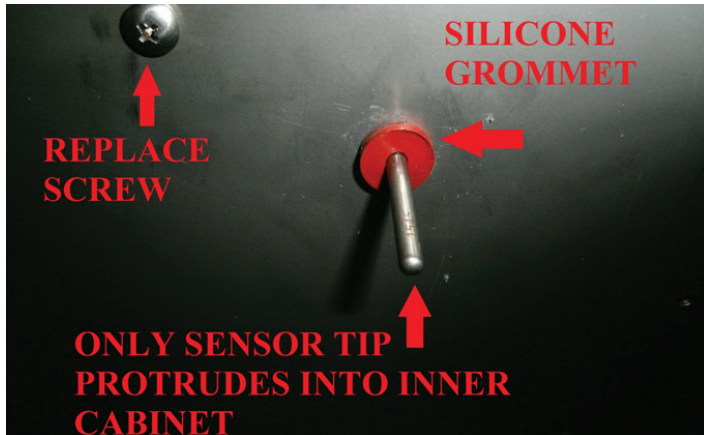

1. Drill a 1/8" hole to mount the sensor assembly. Drill through ONLY the insulation and 1 layer aluminum.
2. Use sheet metal screw to secure bracket into new drilled hole.



3. Insert the new sensor wires into the white 16-pin connector. No polarity. Note rounded side of pin is up. Must click into place.

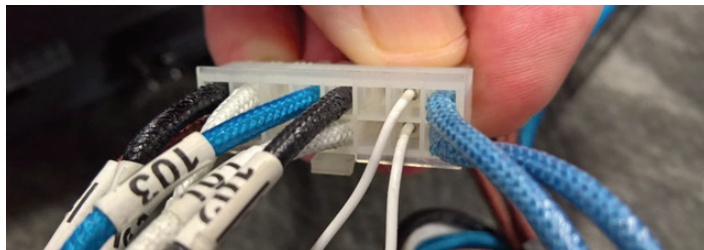

4. Plug 16-pin connector back into control.
5. Zip tie wires back together (if applicable) keeping sensor wires separate from others.

6. Secure top cover back on with screws.
7. Plug unit in and push back into position.

REPROGRAMMING CONTROLS

1. Press power switch ON.
2. When control powers on, press and hold SET knob and TIME button for 10-12 seconds (not 5 seconds).



3. Enter password by rotating knob to desired number and press knob to select. Password is 24025.
4. If you have correct password, you will be in main menu and it will display CONFIG.
5. Use the knob to scroll over to OFST2 and press SET knob.
6. Rotate the knob to change value from 6 to 10 and press SET to enter value.
7. Use the knob to scroll over to TGAN2 and press knob to enter.
8. Rotate to adjust value from 0.14 to 0.60 and press knob to set.

PARAMETER	OLD VALUE	NEW VALUE
OFST2	+6	+10
TGAN2	+0.14	+0.6

9. Rotate knob to scroll to END, and press to exit menu.
10. Press DISPLAY until actual temp is shown.
EXAMPLE: 142FA
11. Retrofit is complete. *(Continued on next page.)*

Ovens	FL-2374-D-OB
Rev. 0 (10/17)	Page 4 of 17



SENSOR RETROFIT INSTRUCTIONS for OUTBACK STEAKHOUSE OVENS

HOW TO ADD RECIPE 3 FOR BBQ RIBS

1. Turn power switch on and remove meat probe if plugged in. Press cancel button to clear any settings.
2. Press RECIPE button, scroll to “Edt” by rotating SET knob, then press SET knob to enter the recipe edit menu.
3. Choose “rcP03” and press SET knob. Enter the following parameters by rotating the SET knob to the values then pressing the SET knob to lock them in.
 - a. Cook temp 200° then press SET knob
 - b. Hold temp 140° then press SET knob
 - c. Time 05:00 then press SET knob
4. Scroll to “End” and press the SET knob.
5. To verify the recipe parameters, press the RECIPE button, select “rcP03”, press SET knob, press the cook button then press the SET knob 3 times to cycle through the parameters. Verify cook is set at 200°, hold at 140°, and time is 05:00. Press Cancel to exit recipe mode.

**INSTALLATION, OPERATION and MAINTENANCE
MANUAL for Cres Cor
RADIANT OVENS**



**500-CH-SS-DE
500-CH-AL-DE
750-CH-SS-DE
1000-CH-SS-SPLIT-DE**

**500-CH-SS-DX
500-CH-AL-DX
750-CH-SS-DX
1000-CH-SS-SPLIT-DX**

Cabinet model number: _____

Cabinet serial number: _____

Authorized Service Agency: _____

Ph: _____ Fax: _____

Keep this manual for future reference.

Ovens	FL-2374-D-OB
Rev. 0 (10/17)	Page 6 of 17



TABLE OF CONTENTS

SUBJECT	PAGE
INSTALLATION INSTRUCTIONS	3, 4
OPERATING INSTRUCTIONS	
First Time Operation	4
How to Use Control for Cooking & Holding:	
For “-DE” Series Ovens	5
For “-DX” Series Ovens	6
“Recipes” for “-DX” Series Ovens	7
MAINTENANCE INSTRUCTIONS	
How to Clean the Unit	8
Trouble Shooting Guide	9
Oven Illustration	10
Oven Replacement Parts	11
Wiring Diagram For 120/208/240 Volt, 1 Phase	12
Wiring Diagram for 208/240 Volt, 3 Phase	13
SERVICE POLICY and AGENCY LIST	FL-1400

**REGISTERING YOUR EQUIPMENT AT www.crescor.com/service/register
COMPLETING A SURVEY EARNS AN EXTRA 90-DAY LABOR WARRANTY!**

If the equipment will not go into service immediately, please indicate that on the warranty registration. Scan QR code to register your equipment today! If you need a QR reader, visit your App Store on your Smartphone or Tablet.



	WARNING	
RISK OF FIRE OR ELECTRIC SHOCK DO NOT OPEN		
WARNING: TO REDUCE THE RISK OF FIRE OR ELECTRIC SHOCK,		
DO NOT REMOVE COVER (OR BACK)		
NO USER-SERVICEABLE PARTS INSIDE		
REPAIR SHOULD BE DONE BY AUTHORIZED SERVICE PERSONNEL ONLY		

INSTALLATION INSTRUCTIONS

VENTING YOUR OVEN:

1. This cabinet passes the EPA 202 test and complies with section 59 of UL710B for emission of grease-laden air.
2. According to UL, this cabinet does not need to be placed under a ventilation hood.
3. Installation must conform with local codes. The authority having jurisdiction of enforcement of the codes will have the responsibility for making interpretations of the rules.

SPECIFICATIONS: All units are rated 3000 watts/2650 watts at 208 Volts/240 Volts

CMP MODEL NOS.	ELECTRICAL SPECS (AC SERVICE)			ELEC. LOAD		POWER SUPPLY REQUIREMENT				
	Volts	Ph	Hz.	Amps	Volts	Amps	Ph	Wire	Volts	NEMA
SINGLE OVENS										
500CHSSDE	208	1	60	14	208	20	1	2	208	6-20P
500CHALDE	240	1	60	11	240	20	1	2	240	6-20P
750CHSSDE	208	1	60	14	208	20	1	2	208	6-20P
1000CHSSSPLITDE	240	1	60	13	240	20	1	2	240	6-20P
500CHSSDE3	208	3	60	8	208	20	3	3	208	L15-20P
500CHALDE3	240	3	60	7	240	20	3	3	240	L15-20P
750CHSSDE3	208	3	60	8	208	20	3	3	208	L15-20P
1000CHSSSPLITDE3	240	3	60	7	240	20	3	3	240	L15-20P

SPECIFICATIONS: All units are rated 2000 watts.

CMP MODEL NOS.	ELECTRICAL SPECS (AC SERVICE)			ELEC. LOAD		POWER SUPPLY REQUIREMENT				
	Volts	Ph	Hz.	Amps	Volts	Amps	Ph	Wire	Volts	NEMA
SINGLE OVENS										
500CHSSDE120 750CHSSDE120 1000CHSSSPLITDE120	120	1	60	16.6	120	20	1	2	120	5-20P

Model number "AL" is aluminum outer body with stainless steel doors and interior.

"DE" in model number will be substituted with "DX" for "Deluxe" Ovens.

All models designed for AC Service. Model number may include a variety of informational suffix letters.

NOTE: OVENS NEED TO BE INSTALLED BY A QUALIFIED PERSON.

For models rated at 208/240 Volts:

Check the voltage selector switch which is under an access cover on the back of the oven near the power cord.

* Flip the switch "UP" for 208 Volts

* Flip the switch "DOWN" for 240 Volts

MAKE SURE THE SWITCH POSITION MATCHES YOUR POWER SOURCE.

Ovens	FL-2374-D-OB
Rev. 0 (10/17)	Page 8 of 17

INSTALLATION INSTRUCTIONS (continued)

IDENTIFYING YOUR CABINET:

Look for this label on the back of your cabinet. This information is needed when calling for questions or service.

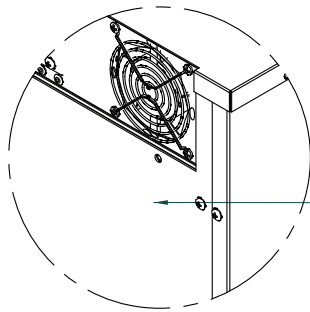

UPPER RIGHT CABINET CORNER



HOW TO INSTALL CABINETS:

1. Remove all packing material from the inside and all vinyl from the outside of oven.
2. Place the oven in a well ventilated area on level floor.
Clearance requirements: 3" (76mm) at the back, 2" (51mm) at the top, 1" (25mm) at both sides.
3. Install the pan slide racks on the sidewalls, if necessary.
4. Slide drip pan(s) onto the bottom of the compartment(s).

HOW TO REVERSE THE DOOR OPENINGS, IF NEEDED:

1. Unscrew and remove the latch from the door and magnetic strike from the cabinet.
2. Unscrew the hinges from the cabinet body and remove door.
3. Remove the screws plugging the mating hinge, latch and strike holes on the opposite sides of the cabinet body and door.
4. Re-mount the hinges to the opposite side of the cabinet and door.
5. Remount the latch and strike to the opposite side

DOOR VENT ADJUSTMENT:

Open the door(s) and move the vent tabs on the inner door(s) as needed to release humidity.

HOW TO CHANGE FROM °F TO °C (if needed)

1. Push the switch on; the light will come on.
2. Push and hold the "SET" button and the button in the lower left hand corner together for 5 seconds.
You have now entered into the menu.
3. Scroll over the "Unit" and change it to "C", then scroll to the "END".

FOR FIRST-TIME OPERATION ONLY:

NOTE: A new oven needs to "burn off" factory oils and glue before its first use. **Do NOT load food into oven until this has been done!**

1. Push lighted switch to turn power "ON"; the light will come on.

NOTE: The letters "LOtPr" (low temperature) will show on the control panel until it reaches 140°F (60°C).

2. Press the "COOK" button.
3. Turn the control knob to show 350°F. Push the knob 3 times to heat the unit. Oven will display "PrEHT".
Run the unit like this for one (1) hour.
4. Turn the unit off and let cool.
5. Wipe the inside clean with detergent and hot water.



Air is VERY HOT when door is opened.

OPERATING INSTRUCTIONS



HOW TO USE THE COOK-N-HOLD CONTROL:

- *Push the lighted switch on the control panel; the oven will start heating and stay in HOLD mode.
- *The display will read “LOTPr” (low temperature) below 140°F. (60°C.).

NOTES: Preheat for one (1) hour after start up before loading the food for best results when retherming or cooking heavy loads.

If a power outage occurs or the cabinet is shut off during a cook cycle, when it is turned on again all lights on the control will flash to indicate a disruption. Control will resume the last cook cycle used. Press any button to stop the blinking.

If your model does not have a food probe, continue to section “-DE OVENS” below.

If your model has a food probe, skip to section “-DX OVENS” on page 5.

-DE OVENS:

Cooking:

1. Press the COOK button.
2. Turn the control knob to the desired cooking temperature between 180°F (82°C) and 350°F (176°C).
3. Push the knob to set the temperature.
4. The control automatically switches to allow you to set HOLD temp. (Continue to step 1 of Holding).

Holding:

(To use as holding cabinet only, skip Cooking section and press HOLD button. Complete steps 1 and 2 below.)

1. Turn the control knob to the desired holding temperature between 135°F (57°C) and 220°F (104°C).
2. Push the knob to set the temperature.
3. The control automatically switches to allow you to set cook time.

Setting the Timer:

1. Turn the control knob to the desired hours/minutes.
2. Push the knob to set the time.
3. The control automatically switches to PREHEAT mode and will display “PrEHt”

Running the Cycle:

1. The control will flash “PUSH StArt” after the cabinet has preheated to the set temp and the alarm will sound.

NOTE: A short beep will occur every 90 seconds as a reminder. This can be turned off in the user menu by holding the knob and the TIME buttons together for 5 seconds, then scrolling to “PSrE”, changing “y” to “n”, scrolling to “End”, and pushing the knob to set.

2. Load foods into oven and close the door.
3. Push the START button to begin the Cooking process. Display will change between the setpoint temperature and the countdown of the timer.
4. The alarm will sound after the time is done and the oven will switch back into HOLD mode. The timer will now count up, showing how long the food has been holding.

Ovens	FL-2374-D-OB
Rev. 0 (10/17)	Page 10 of 17

OPERATING INSTRUCTIONS *(continued)*



-DX OVENS

Cooking:

1. Press the COOK button.
2. Turn the control knob to the desired cooking temperature between 180°F (82°C) and 350°F (176°C).
3. Push the knob to set the temperature.
4. The control automatically switches to allow you to set HOLD temp. (Continue to step 1 below).

Holding:

(To use as holding cabinet only, skip steps 1-4 of Cooking above and press HOLD button. Complete steps 1 and 2 below.)

1. Turn the control knob to the desired holding temperature between 135° (57°C) and 220°F (104°C).
2. Push the knob to set the temperature.
3. The control automatically switches to allow you to set cook time.

If cooking with timer, continue to step 1 below. If cooking with food probe, skip to section “Cooking with Food Probe”.

Cooking with Timer:

1. Turn the control knob to the desired hours/minutes. Oven will switch from COOK to HOLD mode when this time is done.
2. Push the knob to set the time.
3. Oven will switch to PREHEAT mode and control will display “PrEHt”.

Cooking with Food Probe:

NOTE: Make sure probe was plugged in after step 1 of Holding above. If not, insert food probe jack into the panel, press the PROBE button and continue to next step below.

1. Turn the control knob to the desired internal temperature. The oven will switch from COOK to HOLD mode when the probe reaches this temp.
2. Push the knob to set the temperature.

3. Oven will switch to PREHEAT mode and control will display “PrEHt”.

Running the Cycle:

1. The control will flash “PUSH StArt” after the cabinet has preheated to the set temp and the alarm will sound.

NOTE: A short beep will occur every 90 seconds as a reminder. This can be turned off in the user menu by holding the knob and the TIME buttons together for 5 seconds, then scrolling to “PSrE”, changing “y” to “n”, scrolling to “End”, and pushing the knob to set.

2. Load foods into oven, insert probe (if applicable) and close the door.
3. Push the START button to begin the Retherm/Cook process.
 - a. If cooking with timer, display will alternate between the setpoint temperature and the countdown of the timer.
 - b. If cooking with probe, display will show the probe temp.
4. The alarm will sound after the time is done and the oven will switch back into HOLD mode. The timer will now count up, showing how long the food has been holding.

NOTE: At any time, the CANCEL button can be pushed to return the oven back to HOLD mode at the previous set temperature.

The DISPLAY button shows (cycles through) all the values when in each mode:

- “PrEHt” or “PUSH StArt”: Momentarily shows actual oven temperature.
- “COOK (timed)”: Shows home screen, set point, count down time, actual oven temperature.
- “COOK (probe)”: Shows home screen, set point, count up time, actual oven temperature.
- “HOLD”: Shows home screen, set point, count up time, actual oven temperature.

OPERATING INSTRUCTIONS *(continued)*



-DX OVENS, *continued*

RECIPES:

The -DX control can hold up to 18 saved recipes.

To save a recipe:

1. Press the RECIPE button.
2. Turn the knob through the menu until you get to “Edit” and press the knob.
3. Turn the knob to reach the recipe you want to edit. There are 18 blank recipes to customize and save.
4. Press the knob and enter the cook, hold and time, or probe values.
5. After the entering the final value, “Edt” will show again, allowing you to edit another recipe.
6. Press the knob to edit more recipes or turn to “End” to exit the menu.

To use one of the recipes:

1. Push the RECIPE button.
2. Turn the knob to the desired recipe; “rcP01”, “rcP02”, “rcP03”, etc.
3. Push the set button to select and start the preset process. Unit will begin to preheat.
4. Run the cycle as described above by pressing START button after oven has preheated.

Note: The display button will cycle through all the values as before, but will include the recipe number, if using a saved recipe.

Additional Menu Settings:

Press and hold both the TIME button and the knob for 5 seconds to get into the menu.

Here you can set the recipes, temperature units (°C or °F), PUSH START reminder and the datalog settings (USB connection required):

”RECE” allows you to enable or disable the data record feature.

“RECF” allows you set how often (in minutes) a datapoint will be recorded.

“RECD” allows you to set how long (in days) you would like the data to be stored in memory.

Ovens	FL-2374-D-OB
Rev. 0 (10/17)	Page 12 of 17

HOW TO CLEAN THE UNIT:

WARNING

BEFORE cleaning the cabinet:

1. **Unplug cord from wall. Allow cabinet to cool.**
2. **Do NOT hose cabinet with water.**
3. **Do NOT get water on controls.**
4. **Do NOT use abrasives or harsh chemicals.**

- Wipe up spills as soon as possible.
- Clean regularly to avoid heavy dirt build-up.

Cleaning Hints:

1. Use the mildest cleaning procedure that will do the job.
2. Always rub in the direction of polish lines to avoid scratching the surface.
3. Use only a soft cloth, sponge, fibrous brushes, plastic or stainless steel pads for cleaning and scouring.
4. Rinse thoroughly with fresh water after every cleaning operation.
5. Always wipe dry to avoid water marks.

MODELS: 500-CH-SS-D, 750-CH-SS-D & 1000-CH-SS-SPLIT-D SERIES

	SOIL	CLEANER	METHOD
STAINLESS STEEL CABINET Inside and Outside	Routine Cleaning	Soap or mild detergent* and water.	1. Sponge on with cloth 2. Rinse
	Stubborn Spots, Stains	Mild abrasive made for Stainless Steel.	1. Apply with damp sponge or cloth. 2. Rub lightly.
	Burnt on Foods or Grease	Chemical oven cleaner made for Stainless Steel.	Follow oven cleaner manufacturer's directions.
	Hard Water Spots & Scale	Vinegar	1. Swab or wipe with cloth. 2. Rinse and dry.

MODEL: 500-CH-AL-D SERIES *(Aluminum cabinet outside only with stainless steel door and pan slides)*

	SOIL	CLEANER	METHOD
ALUMINUM CABINET Outer body ONLY	Dirt	Mild detergent* and hot water, or mild abrasive cleaner.	1. Use soft, damp cloth. 2. Rinse with hot water. 3. Wipe dry.
		Steam (no strong alkaline additive).	1. Rinse after steam cleaning. 2. Wipe dry.
	Fingerprints, Grease, Oil	Detergent* and hot water.	1. Wipe with soft, damp cloth. 2. Rinse with hot water. 3. Wipe dry.
		Chemical oven cleaner made for aluminum.	Follow oven cleaner manufacturer's directions
		Mild abrasive cleaner. Oily or waxy cleaner.	Apply with soft, clean cloth.
Water Spots	Mild abrasive cleaner.	Wipe with damp cloth.	

**Mild detergents include soaps and non-abrasive cleaners.*

MAINTENANCE INSTRUCTIONS TROUBLE-SHOOTING GUIDE

 WARNING IF UNIT GETS TOO HOT OR WON'T SHUT OFF, DISCONNECT POWER AT BRANCH PANEL. DO NOT UNPLUG CORD!

If hot unit is *NOT* working, first check the following causes:

- | | |
|--|--|
| 1. Cord is unplugged from wall outlet. | 3. Switch(es) are turned off. |
| 2. Circuit breaker/fuse to wall outlet is blown. | 4. Thermostat(s) are turned off, or are set too low. |

IF THE OVEN TURNS ON:

PROBLEM	POSSIBLE CAUSE	SOLUTION
Oven does not heat, or doesn't heat properly	1. Sensor 2. Heater relay 3. Loose connection 4. Oven control 5. High Limit	1. Replace 2. Replace 3. Replace 4. Replace 5. Replace
Heater will not shut off	1. Control defective 2. Heater relay	1. Replace 2. Replace
Vent fans do not shut off	1. Vent fan switch defective 2. Control compartment is still hot.	1. Replace 2. Wait until it cools Check "Heater will not shut off"
Vent fans do not operate (See Note)	1. Vent fan switch defective 2. Vent fan defective	1. Replace 2. Replace
Control will not switch from "COOK" to "HOLD" (timed mode)	1. Oven is in "PROBE" mode ("DX" ovens). 2. Oven control defective	1. Cancel recipe and switch to "TIMED" mode 2. Replace
Control will not switch from "COOK" to "HOLD" (probe mode in "DX" ovens only)	1. Oven is in the "TIMED" mode 2. Probe not plugged in 3. Probe defective 4. Oven control defective	1. Cancel recipe and switch to "PROBE" mode 2. Plug in probe 3. Replace 4. Replace
Control will not switch to "COOK" (probe mode in "DX" ovens only)	1. Oven in "TIMED" mode 2. Probe temperature setting lower than probe temperature 3. Probe not plugged in 4. Oven control defective	1. Switch to "PROBE" mode 2. Set probe temperature to desired temperature 3. Plug in probe 4. Replace

ERROR CODES:

CODE DISPLAYED	CAUSE	SOLUTION
no p	No meat probe	Plug in probe
Err0	Temp probe bad	Replace

NOTE: Vent fans will not operate until the control compartment requires ventilation to limit temperatures. Replacement of electrical components must be done by a qualified electrician.

Refer to our *Service Agency list, FL-1400* (found in the back of this manual), of authorized service centers. Instructions for replacing parts are included in replacement parts list.

Ovens	FL-2374-D-OB
Rev. 0 (10/17)	Page 14 of 17

REPLACEMENT PARTS

Include all information on nameplate when ordering parts

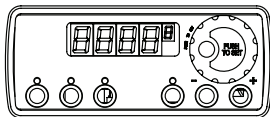
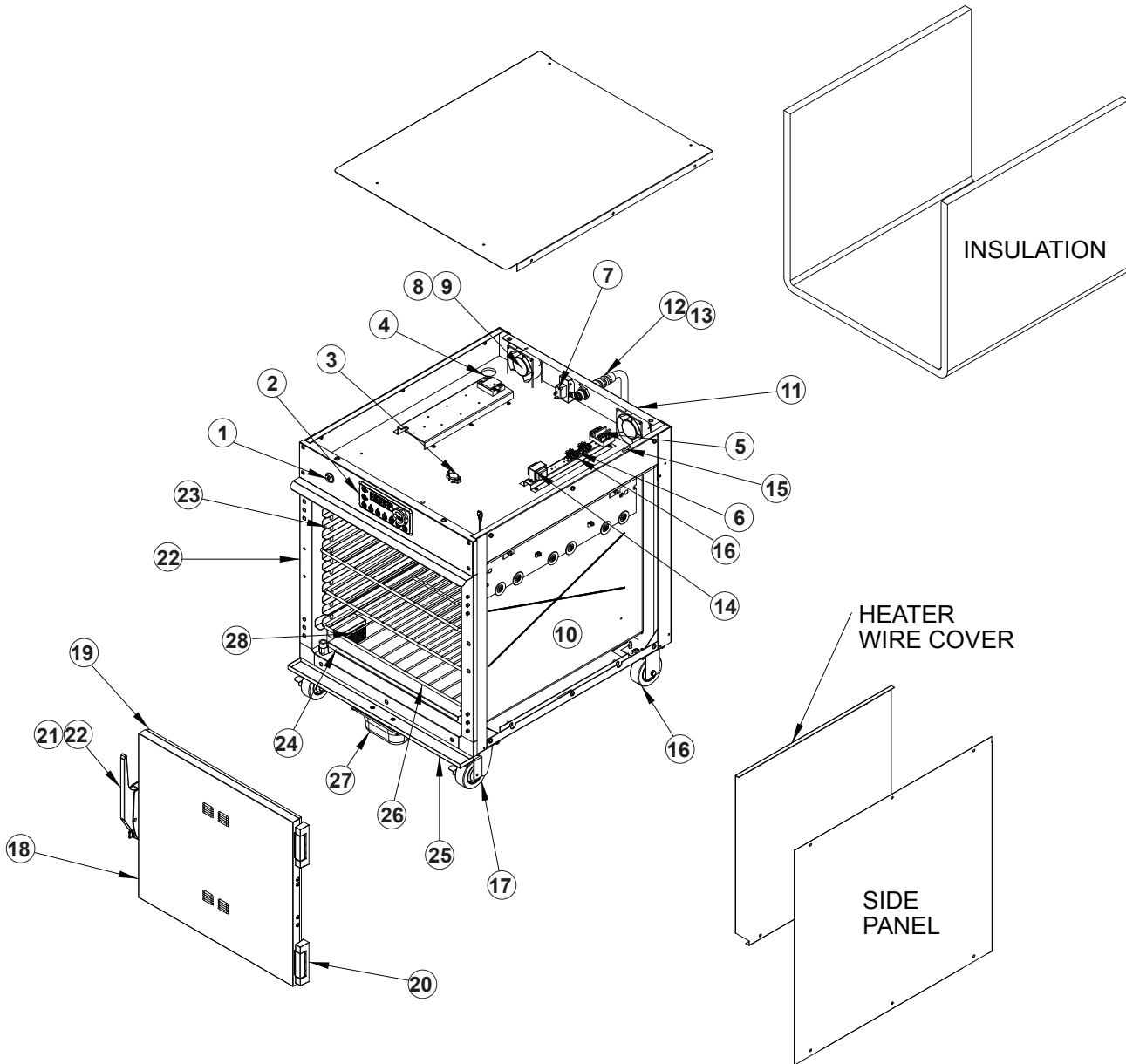

2A "DE" COOK-N-HOLD CONTROL

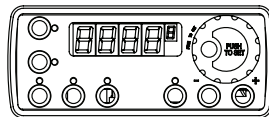

2B "DX" COOK-N-HOLD CONTROL

REPLACEMENT PARTS

Include all information on nameplate when ordering parts

ELECTRICAL REPLACEMENT PARTS

ITEM DESCRIPTION	CMP Part No.	ITEM DESCRIPTION	CMP Part No.
1. Switch (On/Off)	0808-125	10. Heater Kit 240V, 1325W	0811-296-K
2A. "DE" Digital Control	0848-092-24-K	Heater Kit 120V, 1000W	0811-295-K
2B. "DX" Digital Control	0848-092-08-K	11. Hi-Limit	0848-033
2C. Digital Control Probe	0848-091-K	12. Power Cord (3000W, 1Ph)	0810-173-01-K
3. Switch, Fan	0848-034	Power Cord (3000W, 3Ph)	0810-164-01-K
4. Relay	0857-136	Power Cord (2000W, 1Ph)	0810-065-1
5. Terminal Block (Input, 2 Pole)	0852-109	13. Strain Relief	0818-050
6. Terminal Block (3 Pole)	0852-096	14. Transformer	0769-197
7. Switch, toggle	0808-020	15. Audible Alarm	0908-009-01
8. Vent Fan (240V)	0769-174	16. Terminal Block (4 Pole)	0852-119
Vent Fan (120V)	0769-165		
9. Fan Guard	0769-167		

CABINET REPLACEMENT PARTS

ITEM DESCRIPTION	500-CH-SS-D	750-CH-SS-D	1000-CH-SS-SPLIT-D
16. Casters, Rigid	0569-288	0569-288	0569-306-R
17. Casters w/ Brake	0569-287-B	0569-287-B	0569-306-B
18. Door Assembly	1221-570-K	1221-576-K	1221-573-K
19. Door Gasket	0861-270	0861-269	0861-267
20. Hinge Kit (2)	0519-109-K	0519-109-K	0519-109-K
21. Door Latch Kit	1006-122-01-K	1006-122-01-K	1006-122-01-K
22. Latch Strike Kit	1006-122-02-K	1006-122-02-K	1006-122-02-K
23. Pan Slides	0692-202	0692-203	0692-200
24. Drip Pan Ass'y	1017-109	1017-102	1017-115
25. Drip Tray	1017-107	1017-118	1017-112
26. Wire Shelf	1170-030-SS	1170-217	1170-212
27. Clear Drip Pan	1017-058	1017-058	1017-058
28. Strainer	1052-094	1052-093	1052-094
FOR "DX" OVENS ONLY (not shown):			
Probe, Food	0848-112	0848-112	0848-112
Probe Connector	0848-106-02	0848-106-02	0848-106-02

Ovens	FL-2374-D-OB
Rev. 0 (10/17)	Page 16 of 17



5925 Heisley Road • Mentor, OH 44060-1833

WIRING DIAGRAM 120/208/240 Volt, Single Phase

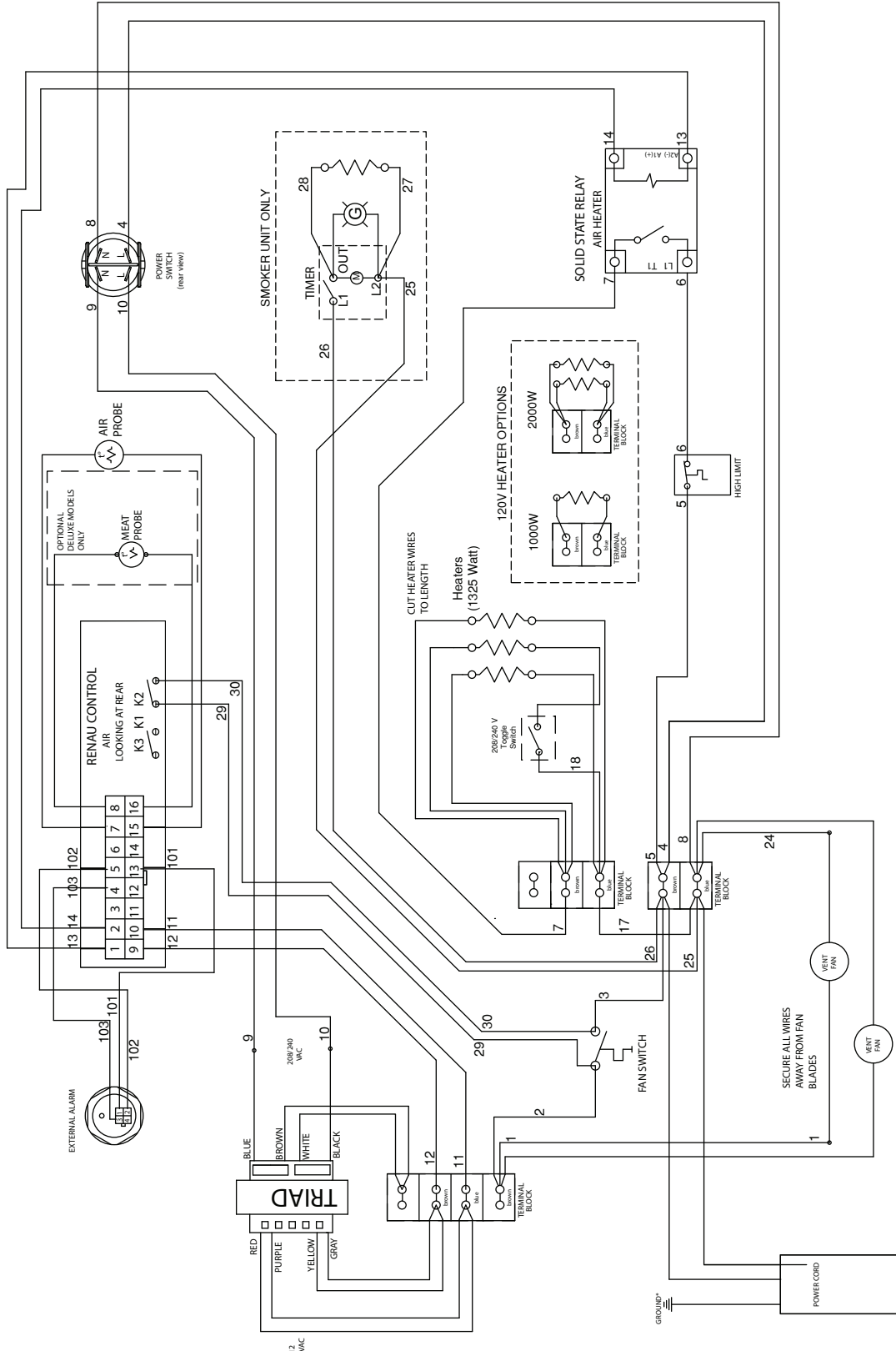

WIRING DIAGRAM 208/240 Volt, Three Phase

