

**INSTALLATION, OPERATION and MAINTENANCE  
MANUAL for Cres Cor  
RADIANT OVENS**



**500-CH-SS-D  
500-CH-AL-D  
750-CH-SS-D  
1000-CH-SS-SPLIT-D**

Cabinet model number: \_\_\_\_\_

Cabinet serial number: \_\_\_\_\_

Authorized Service Agency: \_\_\_\_\_

Ph: \_\_\_\_\_ Fax: \_\_\_\_\_

**Keep this manual for future reference.**

Ovens	<b>FL-2374-D</b>
Rev. 2 (6/14)	Page 2 of 13

## TABLE OF CONTENTS

<b>SUBJECT</b>	<b>PAGE</b>
INSTALLATION INSTRUCTIONS .....	3, 4
OPERATING INSTRUCTIONS .....	5
Illustration, Control Panel .....	6
MAINTENANCE INSTRUCTIONS	
How to Clean the Unit.....	7
Replacement Parts .....	8
Illustration; Ovens .....	9
Trouble Shooting Guide .....	10
Wiring Diagram, 120V .....	11
Wiring Diagram, 208/240V, Single Phase.....	12
Wiring Diagram, 208/240V, Three Phase.....	13
SERVICE POLICY and AGENCY LIST .....	FL-1400

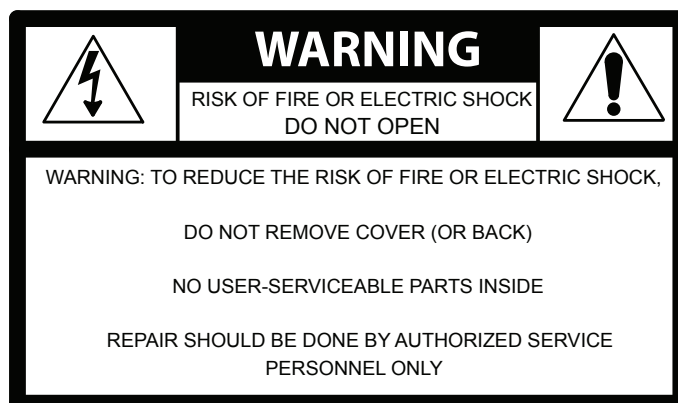

## INSTALLATION INSTRUCTIONS

### VENTING YOUR OVEN:

1. The purpose of ventilating hoods is to direct and capture smoke, grease-laden vapors, heat, odors, or fumes.
2. Low temperature equipment (maximum temperature 250°F/121°C) does not produce heat, odors, fumes, grease-laden vapors or smoke and is not required to be vented.
3. Most jurisdictions consider our low-temperature ovens (maximum temperature is 350°F/177°C) as low-heat appliances not requiring vent hoods.
4. Installation must conform with local codes. The authority having jurisdiction of enforcement of the codes will have the responsibility for making interpretations of the rules.

**SPECIFICATIONS:** All units are rated 3000 watts/2650 watts at 208 Volts/240 Volts

CMP MODEL NOS.	ELECTRICAL SPECS (AC SERVICE)			ELEC. LOAD		POWER SUPPLY REQUIREMENT				
	SINGLE OVENS	Volts	Ph	Hz.	Amps	Volts	Amps	Ph	Wire	Volts
500CHSSD	208	1	60	14	208	20	1	2	208	6-20P
500CHALD	240	1	60	11	240	20	1	2	240	6-20P
750CHSSD	208	1	60	14	208	20	1	2	208	6-20P
1000CHSSSPLITD	240	1	60	13	240	20	1	2	240	6-20P
500CHSSD3	208	3	60	8	208	20	3	3	208	L15-20P
500CHALD3	240	3	60	7	240	20	3	3	240	L15-20P
750CHSSD3	208	3	60	8	208	20	3	3	208	L15-20P
1000CHSSSPLITD3	240	3	60	7	240	20	3	3	240	L15-20P

**SPECIFICATIONS:** All units are rated 2000 watts.

CMP MODEL NOS.	ELECTRICAL SPECS (AC SERVICE)			ELEC. LOAD		POWER SUPPLY REQUIREMENT				
	SINGLE OVENS	Volts	Ph	Hz.	Amps	Volts	Amps	Ph	Wire	Volts
500CHSSD120 750CHSSD120 1000CHSSSPLITD120	120	1	60	16.6	120	20	1	2	120	5-20P

Model number "AL" is aluminum outer body with stainless steel doors and interior.

All models designed for AC Service. Model number may include a variety of informational suffix letters.

**NOTE:** OVENS NEED TO BE INSTALLED BY A QUALIFIED PERSON.

For models rated at 208/240 Volts:  
 Check the voltage selector switch which is under an access cover on the back of the oven near the power cord.

- \* Flip the switch "UP" for 208 Volts
- \* Flip the switch "DOWN" for 240 Volts

**MAKE SURE THE SWITCH POSITION MATCHES YOUR POWER SOURCE.**

Ovens	<b>FL-2374-D</b>
Rev. 2 (6/14)	Page 4 of 13

## INSTALLATION INSTRUCTIONS (continued)

### IDENTIFYING YOUR CABINET:

Look for this label on the back of your cabinet. This information is needed when calling for questions or service.

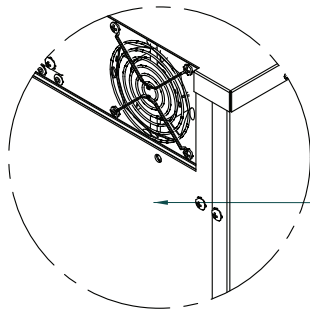

UPPER RIGHT CABINET CORNER



### HOW TO INSTALL CABINETS:

1. Remove all packing material from the inside and all vinyl from the outside of oven.
2. Place the oven in a well ventilated area on level floor.  
**Clearance requirements:** 3" (76mm) at the back, 2" (51mm) at the top, 1" (25mm) at both sides.
3. Install the pan slide racks on the sidewalls, if necessary.
4. Slide drip pan(s) onto the bottom of the compartment(s).

### HOW TO REVERSE THE DOOR OPENINGS, IF NEEDED:

1. Unscrew and remove the latch from the door and magnetic strike from the cabinet.
2. Unscrew the hinges from the cabinet body and remove door.
3. Remove the screws plugging the mating hinge, latch and strike holes on the opposite sides of the cabinet body and door.
4. Re-mount the hinges to the opposite side of the cabinet and door.
5. Remount the latch and strike to the opposite side

### FOR FIRST-TIME OPERATION ONLY:

A new oven needs to "burn off" factory oils and glue before it's first use. **Do NOT load food into oven until this has been done!**

1. Push switch to "ON"; the light will come on.

**NOTE:** The letters "LOTPR" (low temperature) will show on the control panel until it reaches 140°F (60°C).

2. Press the "COOK" button.
3. Push down and turn the control knob to show 200°F. Push the knob again to set the temperature. Run the unit for one (1) hour.
4. Turn the unit off and let cool.
5. Wipe the inside clean with detergent and hot water.

### DOOR VENT ADJUSTMENT:

**Open the door(s) and move the vent tabs on the inner door(s) as needed to release humidity.**



**Air is VERY HOT when door is opened.**

## OPERATING INSTRUCTIONS



### HOW TO USE THE COOK-N-HOLD CONTROL:

\*Push the lighted switch on the control panel; the light will come on and the cabinet will start heating.

\*The display will read “LOTPR” (low temperature) below 140°F. (60°C.).

**NOTE:** Wait one (1) hour after start up before loading the food for best results.

The display will read “PREHT” until the cabinet reaches the set temperature, then it will show “READY”.

### Cooking:

1. Press the COOK button.
2. Turn the control knob to the desired cooking temperature between 200°F (93°C) and 350°F (176°C).
3. Push the knob to set the temperature.
4. The control automatically goes to the HOLD mode. (Continue to step 1 below).

### Holding:

(Press the HOLD button only if you are just holding food),

1. Turn the control knob to the desired holding temperature between 140°F (60°C) and 220°F (104°C).
2. Push the knob to set the temperature.
3. The control automatically goes to the TIME mode.

### Setting the time or Food Probe:

1. If NOT using the Food Probe:
  - a) Turn the control knob to the desired hours/minutes.
  - b) Push the knob to set the time.
2. Using the Food Probe:
 

Plug in the food probe **BEFORE** you enter the **TIME** mode. Otherwise, you have to press the **PROBE** button to set the probe temperature.

  - a) Turn the knob to the desired temperature.
  - b) The timer will stop when the probe reaches the set temperature.
3. Press the **START** button. The display will read “PREHT” until the cabinet reaches the set temperature, then it will show “READY”.
4. Press the **START** again to use this recipe (see Recipes”).

**Note:** Press the knob for 4 seconds to cancel the recipe.

The **DISPLAY** button shows (cycles through) all the values when in each mode:

- “PREHEAT” OR “READY”: momentarily shows the actual cabinet temperature.
- “COOK” (Timed): shows Home screen, set point, count down time, actual cabinet temperature.
- “COOK” (Probe): shows Home screen, set point, count up time, actual cabinet temperature.
- “HOLD”: shows Home screen, set point, count up time, actual cabinet temperature.

Ovens	<b>FL-2374-D</b>
Rev. 2 (6/14)	Page 6 of 13



## RECIPES:

The control can hold up to 18 saved recipes.

### To save a recipe:

1. Press and hold both the TIME button and the knob for 5 seconds. The screen will be flashing. This is the setup menu.
2. Turn the knob through the menu until you get to “Edit”.
3. Press the knob and turn to the recipe you want to edit. There are 18 blank recipes to customize and save.
4. Press the knob and enter the cook, hold and time values.
5. After the entering the final value, “Edit” will show again.
6. Press the knob to edit more recipes or turn to “End” to exit the menu.

### To use one of the recipes:

1. Push one of the three RECIPE group buttons for the recipe number you want.
2. Turn the knob to the recipe you want and press the knob to select.
3. Press the START button to preheat.
4. After it shows “READY”, press the START button again to begin the recipe.

**Note:** The display button will cycle through all the values as before, but will include the recipe number, if using a saved recipe.

## Quick Recipe Note:

You can set “Quick Recipes” for recipes that you use often. This way, when you press a recipe group button and press start, that recipe will start cooking without searching for the recipe number. Recipe numbers can be set up as “quick recipes” as follows:

1. Press and hold both the TIME button and the knob for 5 seconds to get into the menu.
2. Turn the knob to “RBTN” and press the knob. The word “PUSH” will flash.
3. Press one of the recipe group buttons to assign a recipe.

**Note:** Recipe numbers 1-6 can be set up as Group button 1.  
Recipe numbers 7-12 can be set up as Group button 2.  
Recipe numbers 13-18 can be set up as Group button 3.

4. Turn the knob to the recipe number you want to assign to that button and press the knob.

Repeat the process to assign recipes to the other two recipe group buttons; or, turn the knob to “END” the submenu; turn to “END” the menu.

## Additional Menu Settings:

Press and hold both the TIME button and the knob for 5 seconds to get into the menu.

Here you can set the recipes, quick recipes, temperature units (°C or °F) and the datalog settings (USB connection required):

“RECE” allows you to enable or disable the data record feature.

“RECF” allows you set how often (in minutes) a datapoint will be recorded.

“RECD” allows you to set how long (in days) you would like the data to be stored in memory.

## HOW TO CLEAN THE UNIT:

### **WARNING**

#### **BEFORE** cleaning the cabinet:

1. **Unplug cord from wall. Allow cabinet to cool.**
2. **Do NOT hose cabinet with water.**
3. **Do NOT get water on controls.**
4. **Do NOT use abrasives or harsh chemicals.**

- Wipe up spills as soon as possible.
- Clean regularly to avoid heavy dirt build-up.

#### **Cleaning Hints:**

1. Use the mildest cleaning procedure that will do the job.
2. Always rub in the direction of polish lines to avoid scratching the surface.
3. Use only a soft cloth, sponge, fibrous brushes, plastic or stainless steel pads for cleaning and scouring.
4. Rinse thoroughly with fresh water after every cleaning operation.
5. Always wipe dry to avoid water marks.

#### **MODELS: 500-CH-SS-D, 750-CH-SS-D & 1000-CH-SS-SPLIT-D**

	<b>SOIL</b>	<b>CLEANER</b>	<b>METHOD</b>
<b>STAINLESS STEEL CABINET</b>  Inside and Outside	Routine Cleaning	Soap or mild detergent* and water.	1. Sponge on with cloth 2. Rinse
	Stubborn Spots, Stains	Mild abrasive made for Stainless Steel.	1. Apply with damp sponge or cloth. 2. Rub lightly.
	Burnt on Foods or Grease	Chemical oven cleaner made for Stainless Steel.	Follow oven cleaner manufacturer's directions.
	Hard Water Spots & Scale	Vinegar	1. Swab or wipe with cloth. 2. Rinse and dry.

#### **MODEL: 500-CH-AL-D** *(Aluminum cabinet outside only with stainless steel door and pan slides)*

	<b>SOIL</b>	<b>CLEANER</b>	<b>METHOD</b>
<b>ALUMINUM CABINET</b>  Outer body ONLY	Dirt	Mild detergent* and hot water, or mild abrasive cleaner.	1. Use soft, damp cloth. 2. Rinse with hot water. 3. Wipe dry.
		Steam (no strong alkaline additive).	1. Rinse after steam cleaning. 2. Wipe dry.
	Fingerprints, Grease, Oil	Detergent* and hot water.	1. Wipe with soft, damp cloth. 2. Rinse with hot water. 3. Wipe dry.
		Chemical oven cleaner made for aluminum.	Follow oven cleaner manufacturer's directions
		Mild abrasive cleaner. Oily or waxy cleaner.	Apply with soft, clean cloth.
Water Spots	Mild abrasive cleaner.	Wipe with damp cloth.	

*\*Mild detergents include soaps and non-abrasive cleaners.*

Ovens	<b>FL-2374-D</b>
Rev. 2 (6/14)	Page 8 of 13



## REPLACEMENT PARTS

*Include all information on nameplate when ordering parts*

### ELECTRICAL REPLACEMENT PARTS

ITEM DESCRIPTION	CMP Part No.	ITEM DESCRIPTION	CMP Part No.
1. Switch (On/Off)	0808-125	10. Heater Kit 240V, 1325W	0811-296-K
2. Digital Control	0848-092-08-K	Heater Kit 120V, 1000W	0811-295-K
3. Switch, Fan	0848-034	11. Hi-Limit	0848-033
4. Relay	0857-136	12. Power Cord (3000W, 1Ph)	0810-173-01-K
5. Terminal Block (Input)	0852-109	Power Cord (3000W, 3Ph)	0810-164-02
6. Terminal Block	0852-091	Power Cord (2000W, 1Ph)	0810-065-1
7. Switch, toggle	0808-020	13. Strain Relief	0818-050
8. Vent Fan (240V)	0769-174	14. Transformer	0769-197
Vent Fan (120V)	0769-165		
9. Fan Guard	0769-167		

### CABINET REPLACEMENT PARTS

ITEM DESCRIPTION	500-CH-SS-D	750-CH-SS-D	1000-CH-SS-SPLIT-D
16. Casters, Rigid	0569-288	0569-288	0569-306-R
17. Casters w/ Brake	0569-287-B	0569-287-B	0569-306-B
18. Door Assembly	1221-570-K	1221-576-K	1221-573-K
19. Door Gasket	0861-270	0861-269	0861-267
20. Hinge Kit (2)	0519-109-K	0519-109-K	0519-109-K
21. Door Latch Kit	1006-122-01-K	1006-122-01-K	1006-122-01-K
22. Latch Strike Kit	1006-122-02-K	1006-122-02-K	1006-122-02-K
23. Pan Slides	0692-202	0692-203	0692-200
24. Drip Pan	1017-109	1017-117	1017-115
25. Drip Tray	1017-107	1017-118	1017-111
26. Wire Shelf	1170-030-SS	1170-217	1170-212
27. Clear Drip Pan	1017-058	1017-058	1017-058
28. Strainer	1052-094	1052-094	1052-094
Probe, Food	0848-112	0848-112	0848-112
Probe Connector	0848-106-02	0848-106-02	0848-106-02

## REPLACEMENT PARTS

*Include all information on nameplate when ordering parts*

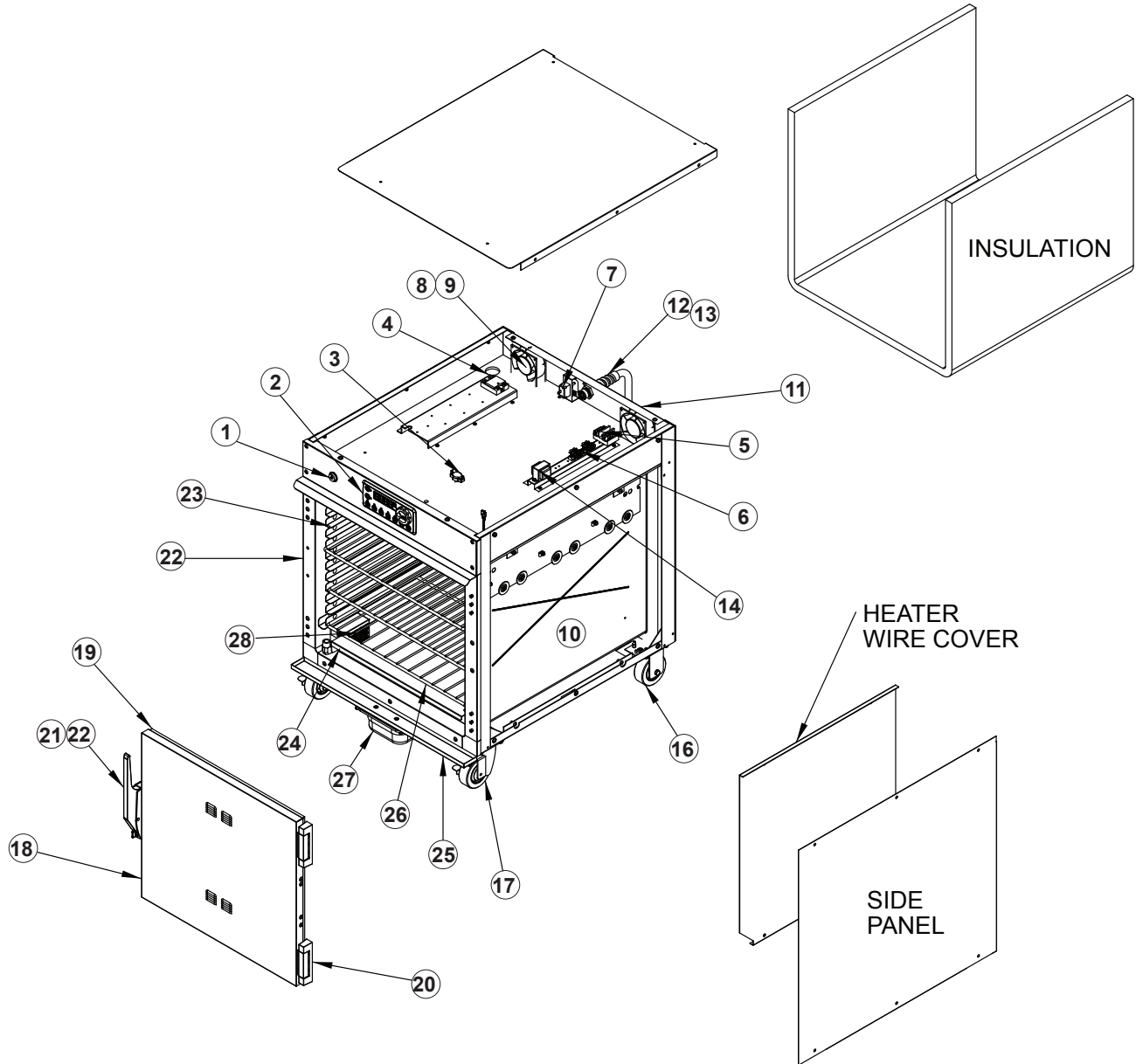

## MAINTENANCE INSTRUCTIONS TROUBLE-SHOOTING GUIDE

** WARNING IF UNIT GETS TOO HOT OR WON'T SHUT OFF, DISCONNECT POWER AT BRANCH PANEL. DO NOT UNPLUG CORD!**

If hot unit is *NOT* working, first check the following causes:

- |  |  |
|--|--|
| 1. Cord is unplugged from wall outlet.           | 3. Switch(es) are turned off.                        |
| 2. Circuit breaker/fuse to wall outlet is blown. | 4. Thermostat(s) are turned off, or are set too low. |

### IF THE OVEN TURNS ON:

PROBLEM	POSSIBLE CAUSE	SOLUTION
Oven does not heat, or doesn't heat properly	1. Sensor 2. Heater relay 3. Loose connection 4. Oven control 5. High Limit	1. Replace 2. Replace 3. Replace 4. Replace 5. Replace
Heater will not shut off	1. Control defective 2. Heater relay	1. Replace 2. Replace
Vent fans do not shut off	1. Vent fan switch defective 2. Control compartment is still hot.	1. Replace 2. Wait until it cools Check "Heater will not shut off"
Vent fans do not operate (See Note)	1. Vent fan switch defective 2. Vent fan defective	1. Replace 2. Replace
Control will not switch from "COOK" to "HOLD" (timed mode)	1. Oven is in "PROBE" mode. 2. Oven control defective	1. Cancel recipe and switch to "TIMED" mode 2. Replace
Control will not switch from "COOK" to "HOLD" (probe mode)	1. Oven is in the "TIMED" mode 2. Probe not plugged in 3. Probe defective 4. Oven control defective	1. Cancel recipe and switch to "PROBE" mode 2. Plug in probe 3. Replace 4. Replace
Control will not switch to "COOK" (probe mode)	1. Oven in "TIMED" mode 2. Probe temperature setting lower than probe temperature 3. Probe not plugged in 4. Oven control defective	1. Switch to "PROBE" mode 2. Set probe temperature to desired temperature 3. Plug in probe 4. Replace

### ERROR CODES:

CODE DISPLAYED	CAUSE	SOLUTION
no p	No meat probe	Plug in probe
Err0	Temp probe bad	Replace

**NOTE:** Vent fans will not operate until the control compartment requires ventilation to limit temperatures. Replacement of electrical components must be done by a qualified electrician.  
 Refer to our *Service Agency list, FL-1400* (found in the back of this manual), of authorized service centers.  
 Instructions for replacing parts are included in replacement parts list.

## WIRING DIAGRAM 120 Volt

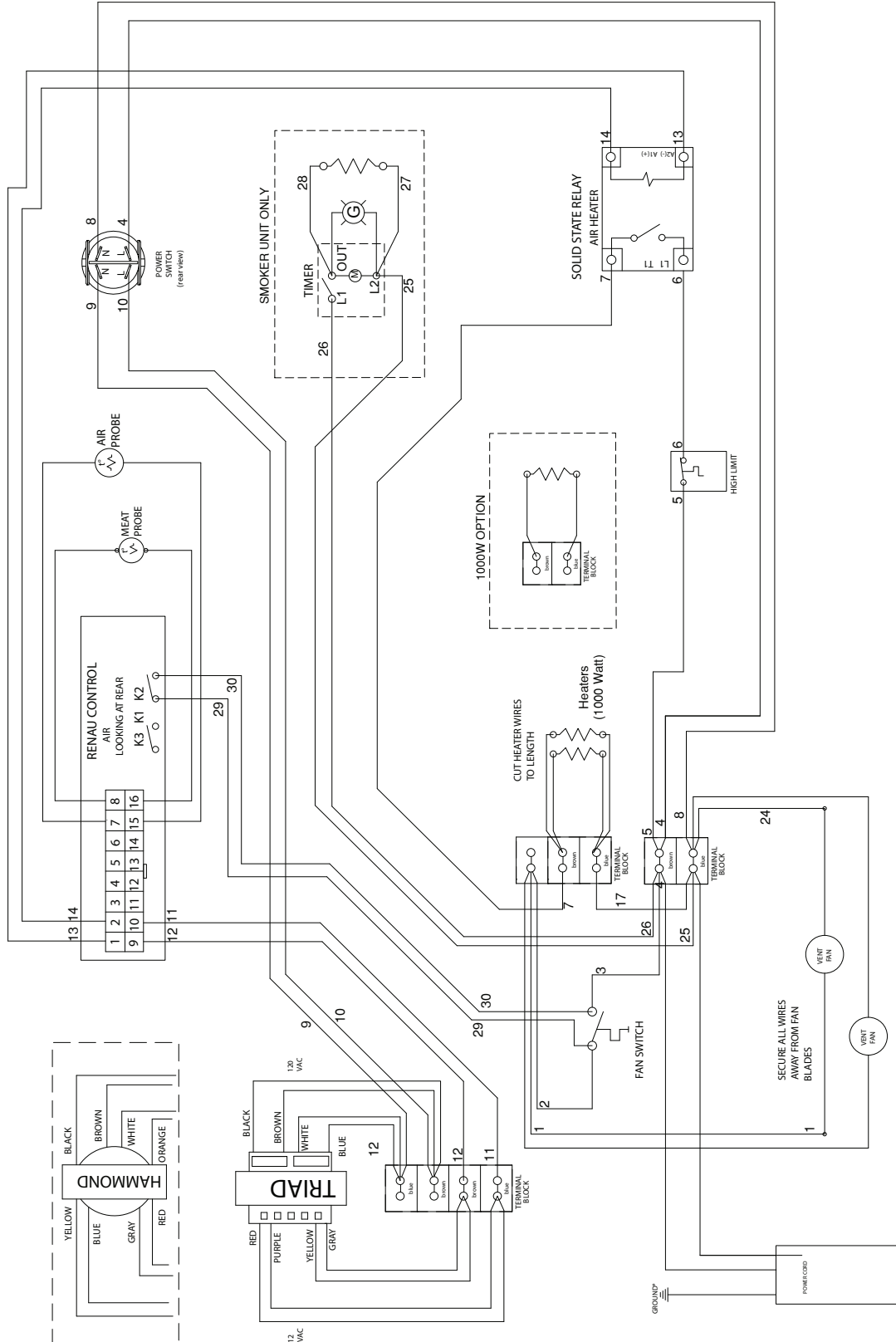

## WIRING DIAGRAM 208/240 Volt, Single Phase

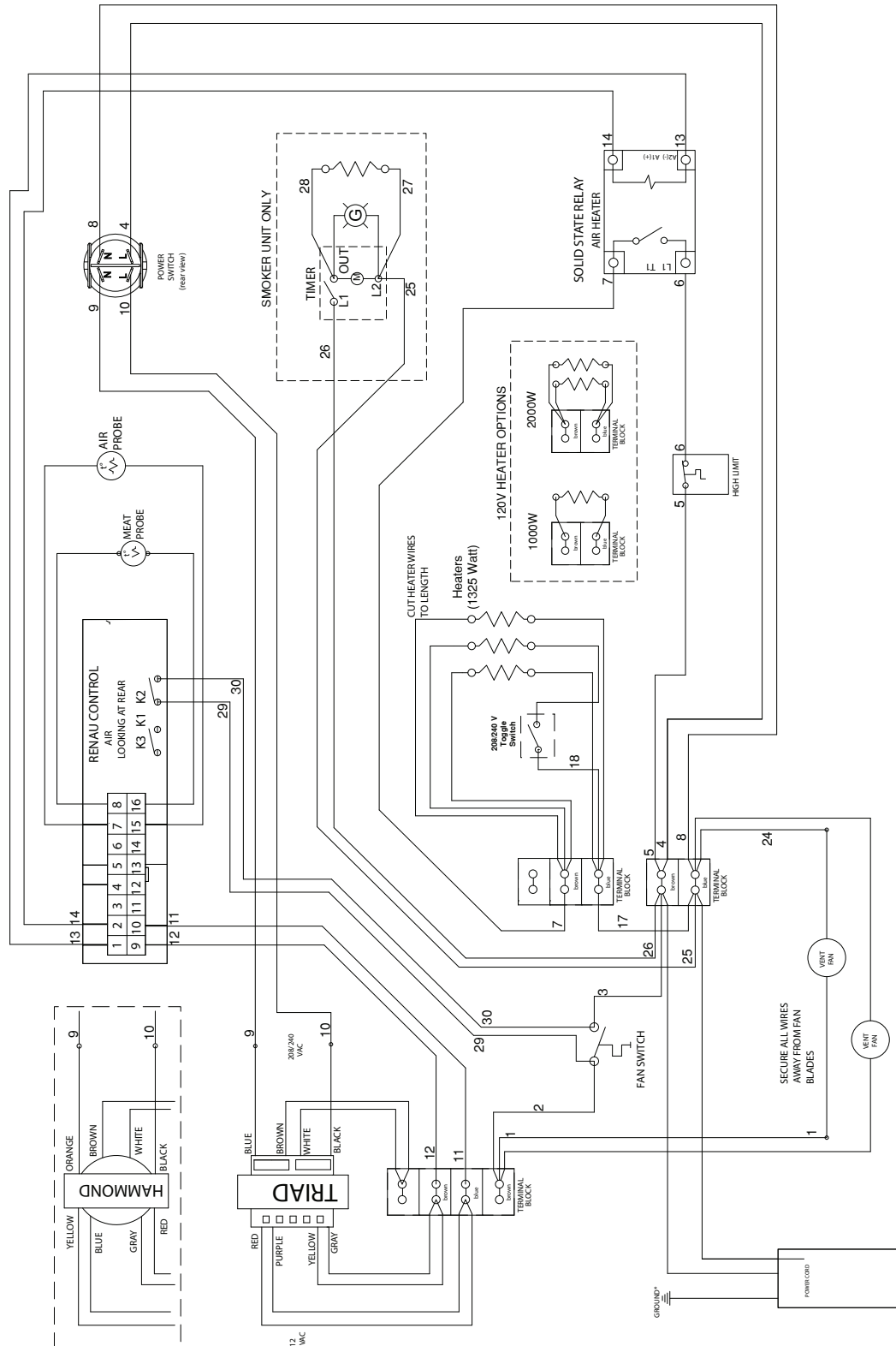

## WIRING DIAGRAM 208/240 Volt, Three Phase

